



Form-Flex BP & B5

All Sizes, All Classes



Installation and Maintenance Manual

TB Wood's Incorporated
Chambersburg, Pennsylvania
Phone: 888-TBWOODS
www.TBWOODS.com

WARNING:

Rotating equipment must be properly guarded.

It is the responsibility of the user to properly guard all rotating equipment to comply with OSHA or any applicable regulations. Failure to properly guard may contribute to severe injury should someone come in contact with the rotating parts or should the rotating part fail.

WARNING:

DO NOT use Wood's products on any primary aircraft drive or any other drive which could endanger human life should a drive component fail.

Proper care with installation and alignment of couplings and equipment will permit a coupling to operate to full capacity, compensate for angular misalignment, and provide very good service life.

Shafts may become misaligned as a result of many natural and unavoidable causes. Heat, vibration, bearing wear, settling of foundations, etc., all tend to alter initial alignment. To ensure long life, recheck alignment after a short period of actual equipment running time.

In general, coupling life is increased when shafts are initially aligned carefully. If this is not done and torque or other forces heavily stress a coupling, it will have little reserve left in which to accommodate misalignment stresses, and might not provide the length of service intended. The closer the alignment T.I.R. is to zero the better the service life of the coupling.

INSTALLATION

Preparation

Inspect the shafts and hubs and make sure they are clean and free from burrs. If the bore is straight, measure the bore and shaft to ensure a proper fit. Check for the proper fit of the keys to the shafts and hubs. If the bore is tapered, check for a good contact pattern.

Straight Bored Hubs

Coupling hubs are normally bored for an interference fit according to AGMA Standard 9002-A86, unless otherwise specified.

If the hub was specified with a clearance fit and set screws are used, install the coupling hubs so that they are in the correct position and tighten the set screw(s). If the hub is bored for an interference fit, the hub should be heated to expand the bore until it is sufficiently larger than the shaft. A hub temperature of approximately 300°F is sufficient for most interference fits. NEVER EXCEED 600°F. **DO NOT SPOT HEAT THE HUB AS IT MAY CAUSE DISTORTION.** After hub has been heated a sufficient amount, quickly position the hub onto the shaft to the desired axial location. Hold the hub in place as it cools.

Taper Bored Hubs

Carefully mount the hub on the shaft without key(s), O-ring and back-up rings (if applicable), and tap lightly with a soft mallet to establish a metal to metal fit. This is the initial position for starting the hub advance. Measure this position, shaft end to hub flange face, with a depth gauge and record the value. Hub draw must be monitored during installation. This may be done using a dial indicator or by use of a shaft stop ring. The method of monitoring the hub draw must be established prior to removing the hub after the initial starting position has been determined. Draw the hub on the shaft the required distance to achieve the level of interference desired. Heat may be required to achieve the proper fit. **DO NOT SPOT HEAT THE HUB AS IT MAY CAUSE DISTORTION.** The amount of hub draw is dependent upon the taper angle, level of required interference, and bore diameter. Install the shaft-retaining device provided with the shaft to hold the hub in place.

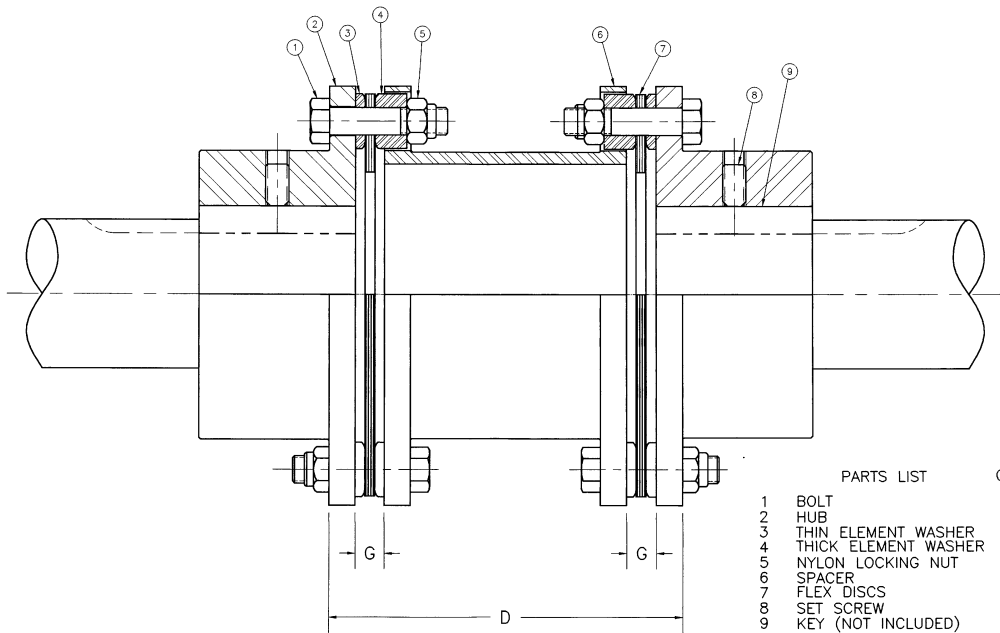

FIGURE 1

PARTS LIST		QTY.
1	BOLT	12
2	HUB	2
3	THIN ELEMENT WASHER	12
4	THICK ELEMENT WASHER	12
5	NYLON LOCKING NUT	12
6	SPACER	1
7	FLEX DISCS	2
8	SET SCREW	4
9	KEY (NOT INCLUDED)	2

Spacer Sub-Assembly

1. Move the equipment to be connected into position. Set the gap between the hub faces to the required distance between shaft ends, “D” dimension in Figure 1. Set the average gap between flanges to the “G” dimension shown in Table 1 for the proper size coupling.

TABLE 1 – FLANGE TO FLANGE, DIMENSION “G” – INCHES

SIZE	33	38	43	48	53	58	63	68
G	.285	.335	.465	.495	.520	.555	.600	.849
±	.010	.010	.010	.010	.010	.015	.015	.015

2. Assemble the flex discs to the spacer as shown in Figure 2. Ensure that the beveled part of the washer is against the flex disc. Tighten the nylon locking nuts shown in Figure 2 to the proper torque value as indicated in Table 2 for the respective size coupling.

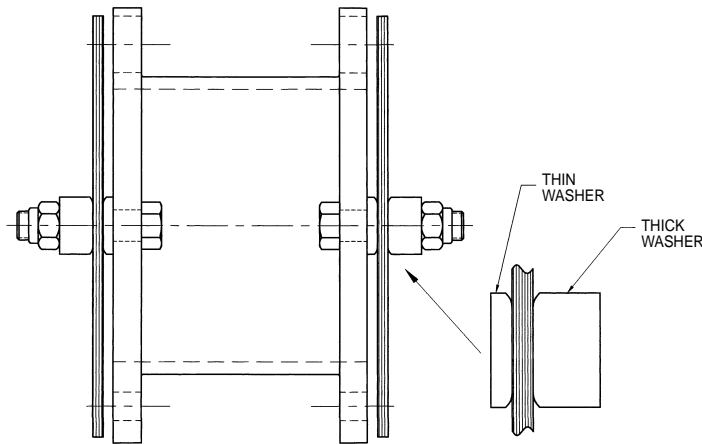

BOLT ORIENTATION IS NOT CRITICAL

FIGURE 2

NOTE: The flex disc are designed for a specific thickness and are not to be used for axial adjustments.

3. Bring the equipment into an approximate good alignment by attaching one end of the spacer to the equipment via a hub. **Be sure the spacer assembly is fully supported at this time. Damage to the connected disc packs may result if the spacer is not fully supported.** Assemble the spacer to the hub via the same method as Item 2 (see figure 2 for reference). Secure the bolts with the nylon locking nuts and tighten to the proper torque value shown in Table 2 for the respective size coupling.
4. With one end of the coupling attached, align the two pieces of equipment well enough to assemble the opposite end of the spacer to its hub in the same manner as above.

TABLE 2 – NUT TIGHTENING TORQUE (LIGHTLY OILED THREADS ON STAINLESS FASTENERS)

SIZE	33	38	43	48	53	58	63	68
FT-LB	8	17	40	40	60	120	120	200

ALIGNMENT

1. Attach a dial indicator to each hub. Indicate a point on the nearest spacer flange face as shown in Figure 3. Any method may be used to attach the dial indicator to the hub as long as it is firmly attached.
2. Rotate the coupling 360° to locate the minimum reading on the dial, then rotate the body or face of the indicator so that the zero reading lines up with the pointer.
3. Rotate the coupling 360° while watching the indicator for misalignment readings. The driver and driven equipment will be aligned when the maximum indicator readings are within the allowable limits as shown in Table III. Adjust the equipment as necessary to comply with the limits.
4. Repeat this method for the other end of the coupling.
 Note: When the equipment is properly aligned, it is advisable to dowel a right angle gearbox to its base. It has been found from experience that right angle gearboxes tend to creep in a counter rotational direction. Recheck alignment after doweling.
5. With equipment aligned and coupling assembled, make sure all bolts and washers are in their proper orientation. As stated previously, the beveled part of the washer must be against the flex discs as shown in Figure 2.

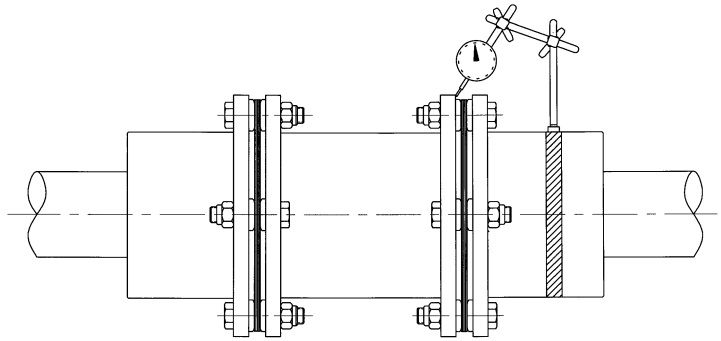

FIGURE 3

IMPORTANT: To ensure long life, recheck alignment after a short period (one to two hours) of actual equipment running time. At this time also re-torque the nylon locking nuts to the values shown in Table 3.

TABLE 3 – TOTAL INDICATOR READING, MAXIMUM; INCHES

SIZE	33	38	43	48	53	58	63	68
T.I.R.*	.024	.030	.034	.039	.041	.046	.052	.056

*Equivalent to .3° per flex element. Lower T.I.R. readings will provide better alignment of shafts and longer service life.
 NOTE: The closer to zero misalignment the better the service that can be expected.

REPAIR PARTS

SIZE	REPAIR KIT	FLEX DISC
	PART #	PART #
33	B033RKA	B0334101
38	B038RKA	B0384101
43	B043RKA	B0434101
48	B048RKA	B0484101
53	B053RKA	B0534101
58	B058RKA	B0584101
63	B063RKA	B0634101
68	B068RKA	B0684101

Repair Kit contains:
 All Hardware and 1 Flex Disc Pack
(2 required per coupling)

Flex Disc Kit contains:
 1 Flex Disc Pack
(2 required per coupling)