

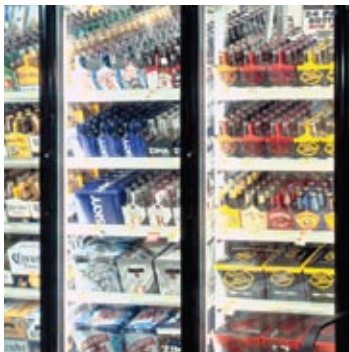

aerospace  
climate control  
electromechanical  
filtration  
fluid & gas handling  
hydraulics  
pneumatics  
process control  
sealing & shielding



# Catalog 201

Condensed Catalog of Sporlan Products

SEPTEMBER 2008



ENGINEERING YOUR SUCCESS.

This catalog is a condensed version of the complete Sporlan Catalog. By including a minimum of engineering information we are able to provide a concise reference to pertinent data and specifications on Sporlan products.

For additional engineering information, a complete Sporlan Catalog or CD, please contact your nearest Sporlan Sales Office, Authorized Sporlan Wholesaler or log on to [www.sporlan.com](http://www.sporlan.com).

<b>CONTENTS</b>	<b>Page</b>	<b>For complete product information see Bulletin number</b>
Acid Test Kits	72	40-10
Accumulators	46	40-10-7
Ball Valves	49	Form 50-172
Catch-All® Filter-Driers Liquid & Suction Line	39	40-10
Crankcase Pressure Regulating Valves	55	90-10
Defrost Differential Pressure Regulating Valves	60	Contact your Sporlan Sales Engineer
Diaphragm Industrial Solenoid Valves	36	30-10
Discharge Bypass Valves	53	90-40
Electronic Temperature Control Systems	65	100-9, 100-20, 100-40, 100-50-1, 100-50-2, 100-50-3, 100-60
Evaporator Pressure Regulating Valves	62	90-20, 90-20-1, 90-20-2
Head Pressure Control Valves	57	90-30
Level Master Liquid Level Control	29	60-15
OF Series Oil Filter	72	110-10
Oil Level Control System	70	110-10
Receivers	48	20-10
Refrigerant Distributors	30	20-10
Reversible Heat Pump Filter-Driers	45	40-10
See • All® Moisture & Liquid Indicators	50	70-10
Solenoid Valves	31	30-10
Strainers	52	80-20
Suction Filters	51	80-10
Thermostatic Expansion Valves	3	10-9, 10-10
Three Way Heat Reclaim Valves	37	30-20

\*To request individual Sporlan Product Bulletins, contact your nearest Sporlan Sales Office or Wholesaler, write Sporlan Division, Washington, Missouri or visit our website at [www.sporlan.com](http://www.sporlan.com).

Catalog 201, September 2008 supersedes Catalog 201 dated May 2007 and all prior publications.  
Copyright 2008 by Parker Hannifin Corporation, Washington, Missouri 

**FOR USE ON REFRIGERATION and/or AIR CONDITIONING SYSTEMS ONLY**

# ▼ THERMOSTATIC EXPANSION VALVES (TEV)

## Valve Nomenclature / Ordering Instructions

### EXAMPLE

<b>EG</b>	<b>V</b>	<b>E</b> - <b>1</b> - <b>C</b>	<b>3/8" ODF SOLDER</b> X	<b>1/2" ODF SOLDER</b> X	<b>1/4" ODF SOLDER</b> X	<b>5'</b>		
Body Type	<b>Sporlan Code – Refrigerant Element Label Color Code</b> F = R-12 Yellow   V = R-407A Green E = R-13 Blue   N = R-407C Lt. Brown V = R-22 Green   S = R-408A Purple G = R-23 Blue   F = R-409A Yellow M = R-124 Blue   Z = R-410A Rose J = R-134a Blue   V = R-422D Green X = R-401A Pink   R = R-502 Purple L = R-402A Sand   W = R-503 Blue S = R-404A Orange   P = R-507 Teal W = R-508B Blue	"E" specifies external equalizer. Omission of letter "E" indicates valve with internal equalizer. e.g. EGV-1-C	Nominal Capacity in Tons	Thermostatic Charge	Inlet Connection Size and Style	Outlet Connection Size and Style	External Equalizer Connection Size and Style	Capillary Tubing Length Inches or Feet

## Recommended Thermostatic Charges\*

### SPORLAN SELECTIVE CHARGES ENGINEERED for PEAK PERFORMANCE for EACH SPECIFIC APPLICATION

APPLICATION	REFRIGERANT										ACTUAL THERMOSTATIC CHARGES
	12, 409A	22, 422D, 407A	410A	134a	401A	402A	404A, 408A	407C	502	507	
Air Conditioning	FCP60	—	—	JCP60	XCP60	—	—	—	—	—	FCP60
	—	VCP100	—	—	—	—	—	NCP100	—	—	VCP100
	—	—	ZCP200	—	—	—	—	—	—	—	ZCP200
	—	VGA	—	—	—	—	—	NGA	—	—	VGA
	—	—	—	—	—	—	SCP115	—	RCP115	—	SCP115
Commercial Refrigeration 50°F to -10°F	—	—	ZGA	—	—	—	—	—	—	—	ZGA
	FC	—	—	JC	XC	—	—	—	—	—	FC
	—	VC	—	—	—	—	—	NC	—	—	VC
	—	—	—	—	—	—	SC	—	RC	—	SC
Low Temperature Refrigeration 0°F to -40°F	—	—	—	—	—	LC	—	—	—	PC	PC
	FZ	—	—	—	—	—	—	—	—	—	FZ
	FZP	—	—	—	—	—	—	—	—	—	FZP
	—	VZ	—	—	—	—	—	—	—	—	VZ
	—	VZP40	—	—	—	—	—	—	—	—	VZP40
	—	—	—	—	—	LZ	SZ	—	RZ	PZ	SZ
Extreme Low Temperature Refrigeration -40°F to -100°F	—	—	—	—	—	LZP	SZP	—	RZP	PZP	SZP
	—	VX	—	—	—	—	—	—	—	—	VX
	—	—	—	—	—	LX	SX	—	RX	PX	SX

#### \*APPLICATION FACTORS:

- The Type ZP charges have essentially the same characteristics as the Type Z charge with one exception: they produce a pressure limit Maximum Operating Pressure (MOP). ZP charges are not intended as replacements for Z charges. Each should be selected for its own unique purpose.
- All air conditioning and heat pump charges are intended for use with externally equalized valves.
- Type L liquid charges are also available for most commonly used refrigerants in most element sizes.
- The Type X charges are not to be used with "EBS" and "O" valves.
- If in doubt as to which charge to use, review the section on thermostatic charges in Bulletin 10-9 or contact Sporlan Division of Parker, Washington, Missouri with complete system data.
- For dual temperature applications, use the "C" charge.
- The "C" charge may be used on applications down to -30°F on R-22, R-404A and R-507.

## TEV Capacity Ratings

FOR REFRIGERANTS: 22, 134a, 401A, 402A, 404A, 407C, 408A, 409A, 410A, 422D, 507

TEV capacity ratings for R-22, R-134a, R-401A, R-402A, R-404A, R-407C, R-408A, R-409A, R-410A, R-422D, and R-507 are based on vapor free 100°F liquid refrigerant entering the expansion valve, a maximum opening superheat of 7°F, and a standard factory air test superheat setting. A discussion of the relationship between valve capacities and superheat settings can be found in Bulletin 10-9.

The ratings for evaporator temperatures 40°F, 20°F, -10°F, -40°F in the capacity tables are in accordance with ANSI/ARI

Standard Number 750. TEVs are tested in accordance with ANSI/ASHRAE 17.

TEV models featuring the mechanical pressure limit style thermostatic elements, i.e., the Types G(PL) and C(PL) TEVs, are now obsolete. Consult Bulletin 210-10-17 for additional information on this subject and replacement valves.

For TEV capacity ratings at operating conditions not shown in the following tables, contact Sporlan Division of Parker.



# TEV CAPACITIES - TONS

# 22, 422D, 407C

## AIR CONDITIONING and HEAT PUMP APPLICATIONS

VALVE TYPES	NOMINAL CAPACITY	REFRIGERANT								
		22			422D <sup>①</sup>			407C		
		RECOMMENDED THERMOSTATIC CHARGE								
		VCP100, VGA <sup>②</sup>								
EVAPORATOR TEMPERATURE °F										
40°    20°    0°    40°    20°    0°    40°    20°    0°										
R, RC	1	1.0	1.1	1.0	0.71	0.76	0.66	0.9	1.0	0.9
R, RC	1-1/2	1.8	1.9	1.7	1.25	1.32	1.15	1.6	1.7	1.5
R, RC	2	2.3	2.5	2.2	1.64	1.74	1.51	2.1	2.3	2.0
R, RC	3	3.2	3.5	3.1	2.28	2.42	2.10	2.9	3.2	2.8
R, RC	4	4.2	4.6	4.1	2.99	3.17	2.75	3.9	4.1	3.6
R, RC	5	5.0	5.5	4.9	3.56	3.78	3.27	4.6	4.9	4.3
R, RC	6	6.0	6.5	5.3	4.28	4.53	3.54	5.5	5.9	4.7
R	8	8.0	8.7	7.8	5.70	6.04	5.24	7.4	7.9	6.9
R	10	10.4	11.4	10.2	7.44	7.88	6.83	9.6	10.3	9.0
R	12	12.1	13.2	11.8	8.62	9.14	7.92	11.1	11.9	10.5
RIVE <sup>③</sup>	2	2.1	2.3	2.1	1.53	1.62	1.40	2.0	2.1	1.8
RIVE <sup>③</sup>	3	3.4	3.7	3.3	2.42	2.57	2.23	3.1	3.4	2.9
RIVE <sup>③</sup>	4	4.2	4.6	4.1	2.98	3.16	2.74	3.8	4.1	3.6
RIVE <sup>③</sup>	5	4.5	4.9	4.4	3.22	3.42	2.96	4.2	4.4	3.9

REFRIGERANT	LIQUID TEMPERATURE ENTERING TEV °F														
	0°	10°	20°	30°	40°	50°	60°	70°	80°	90°	100°	110°	120°	130°	140°
22	1.56	1.51	1.45	1.40	1.34	1.29	1.23	1.17	1.12	1.06	1.00	0.94	0.88	0.82	0.76
422D	1.99	1.90	1.80	1.70	1.60	1.50	1.41	1.31	1.20	1.10	1.00	0.90	0.79	0.68	0.57
407C	1.69	1.62	1.55	1.49	1.42	1.35	1.28	1.21	1.14	1.07	1.00	0.93	0.85	0.77	0.69

These factors include corrections for liquid refrigerant density and net refrigerating effect and are based on an evaporator temperature of 0°F. However, they may be used for any evaporator temperature from -40°F to 40°F since the variation in the actual factors across this range is insignificant.

EVAPORATOR TEMPERATURE °F	PRESSURE DROP ACROSS TEV (psi)											
	30	50	75	100	125	150	175	200	225	250	275	300
40°	0.55	0.71	0.87	1.00	1.12	1.22	1.32	1.41	1.50	1.58	1.66	1.73
20° & 0°	0.49	0.63	0.77	0.89	1.00	1.10	1.18	1.26	1.34	1.41	1.48	1.55

**TEV Capacity = TEV Rating x CF Liquid Temperature x CF Pressure Drop** — Example: Actual capacity of a nominal 2 ton R-22 Type S valve at 20°F evaporator, 100 psi pressure drop across the TEV, and 90°F liquid temperature entering the TEV = 2.18 (from rating chart) x 1.06 (CF liquid temperature) x 0.89 (CF pressure drop) = 2.06 tons.

- ① R-422D can be used in a system with R-22 valves, but the TEV capacity will be reduced. Please verify valve capacity will handle system load.
- ② The RC valve for R-22 applications is only available with a VGA element.
- ③ The Nominal Capacity of the valve is increased by 15% when the Rapid Pressure Balancer (RPB) feature is used. A cross drilling is part of the internal construction of the RPB feature and this drilling provides the additional refrigerant flow.

# TEV CAPACITIES - TONS

# 410A

## AIR CONDITIONING and HEAT PUMP APPLICATIONS

VALVE TYPES	NOMINAL CAPACITY	REFRIGERANT		
		410A		
		RECOMMENDED THERMOSTATIC CHARGE		
		ZCP200, ZGA <sup>①</sup>		
EVAPORATOR TEMPERATURE °F				
40°    20°    0°				
R, RC	1	1.2	1.3	1.2
R, RC	1-1/2	2.1	2.3	2.0
R, RC	2	2.7	3.0	2.7
R, RC	3	3.8	4.1	3.7
R, RC	4	5.0	5.4	4.9
R, RC	5	5.9	6.5	5.8
R, RC	6	7.1	7.8	6.3
R	8	9.5	10.4	9.3
R	12-1/2	12.3	13.5	12.1
R	15	14.3	15.7	14.0

VALVE TYPES	NOMINAL CAPACITY	REFRIGERANT		
		410A		
		RECOMMENDED THERMOSTATIC CHARGE		
		ZGA		
EVAPORATOR TEMPERATURE °F				
40°    20°    0°				
OZE-20	20	19.7	21.6	20.4
OZE-25	25	23.7	25.9	24.5
OZE-35	35	32.6	35.6	33.6
OZE-50	50	49.3	54.0	51.0
OZE-60	60	59.2	64.8	61.2

VALVE TYPES	CARTRIDGE TYPE	40°	20°	0°	
EBQ, SBQ	AAA	1/3	0.4	0.5	0.4
EBQ, SBQ	AA	2/3	0.9	1.0	0.9
EBQ, SBQ	A	1-1/2	1.9	2.1	1.8
EBQ, SBQ	B	3	3.4	3.7	3.2
EBQ, SBQ	C	5-1/2	6.2	6.8	5.9

REFRIGERANT	LIQUID TEMPERATURE ENTERING TEV °F													
	40	50	60	70	80	90	100	110	120	130	140			
410A	1.39	1.31	1.23	1.17	1.12	1.06	1.00	0.94	0.88	0.82	0.76			

EVAPORATOR TEMPERATURE °F	PRESSURE DROP ACROSS TEV (psi)							
	80	120	160	200	240	280	320	360
40°	0.71	0.87	1.00	1.12	1.22	1.32	1.41	1.50
20° & 0°	0.63	0.77	0.89	1.00	1.10	1.18	1.26	1.34

① The RC valve for R-410A applications is only available with a ZGA element.

# TEV CAPACITIES - TONS

# 404A, 408A

## COMMERCIAL and LOW TEMPERATURE REFRIGERATION APPLICATIONS

VALVE TYPES	NOMINAL CAPACITY	REFRIGERANT											
		404A						408A					
		RECOMMENDED THERMOSTATIC CHARGE											
		SC, SCP115			SZ, SZP			SC, SCP115			SZ, SZP		
		EVAPORATOR TEMPERATURE °F											
40°	20°	0°	-10°	-20°	-40°	40°	20°	0°	-10°	-20°	-40°		
F-EF-G-EG	1/8	0.15	0.16	0.15	0.15	0.13	0.11	0.20	0.21	0.20	0.22	0.19	0.16
F-EF-G-EG	1/6	0.23	0.24	0.23	0.24	0.21	0.17	0.31	0.33	0.32	0.34	0.30	0.25
F-EF-G-EG	1/4	0.29	0.31	0.29	0.31	0.27	0.22	0.39	0.42	0.41	0.43	0.38	0.32
F-EF-G-EG	1/2	0.56	0.59	0.56	0.59	0.51	0.42	0.75	0.81	0.77	0.83	0.72	0.61
F-EF-G-EG	1	1.02	1.10	1.04	1.10	0.94	0.79	1.37	1.50	1.44	1.54	1.34	1.14
F-EF-G-EG	1-1/2	1.53	1.61	1.39	1.47	1.26	1.05	2.05	2.19	1.92	2.06	1.79	1.53
F&EF(Ext)-G&EG(Ext)-S	2	2.04	2.14	1.84	1.96	1.68	1.40	2.74	2.92	2.54	2.74	2.38	2.04
S	3	2.86	3.00	2.52	2.45	2.10	1.75	3.83	4.08	3.48	3.43	2.98	2.54
S	4	4.08	4.28	3.60	3.42	2.94	2.45	5.48	5.83	4.97	4.80	4.17	3.56
S (Ext)	6	5.61	5.12	4.27	4.52	3.84	2.97	7.53	6.97	5.90	6.34	5.45	4.32
S (Ext)	7	7.14	6.51	5.44	5.76	4.90	3.79	9.58	8.87	7.50	8.08	6.94	5.51
H	3	2.85	2.72	2.32	2.45	2.08	1.65	3.83	3.71	3.20	3.434	2.95	2.41
H	4	4.08	3.89	3.15	3.42	2.91	2.32	5.48	5.30	4.34	4.80	4.13	3.37
H	6-1/2	6.63	6.33	5.12	5.32	4.52	3.60	8.90	8.61	7.06	7.46	6.41	5.24
H	9	9.69	9.25	7.48	6.11	5.19	4.13	13.0	12.6	10.3	8.57	7.36	6.01
H	12	13.3	12.7	10.2	9.79	8.31	6.62	17.8	17.2	14.1	13.7	11.8	9.60
M	15	16.1	17.1	13.1	13.8	12.4	10.0	21.6	23.3	18.0	19.3	17.5	14.5
M	20	21.0	22.3	16.4	17.3	15.5	12.5	28.2	30.3	22.7	24.2	22.0	18.2
M	25	26.2	27.8	20.5	20.3	18.2	14.7	35.2	37.8	28.3	28.4	25.8	21.4
M	30	31.6	33.5	24.7	23.5	21.1	17.0	42.4	45.7	34.1	32.9	29.9	24.7

BALANCED PORT THERMOSTATIC EXPANSION VALVES													
BF-EBF-SBF	AAA	0.23	0.24	0.23	0.24	0.21	0.17	0.31	0.33	0.32	0.34	0.30	0.25
BF-EBF-SBF	AA	0.46	0.49	0.46	0.45	0.39	0.32	0.62	0.66	0.64	0.63	0.55	0.47
BF-EBF-SBF	A	1.02	1.10	1.04	1.10	0.94	0.79	1.37	1.50	1.44	1.54	1.34	1.14
BF-EBF-SBF	B	1.89	1.98	1.66	1.60	1.37	1.14	2.53	2.70	2.30	2.24	1.95	1.66
BF-EBF-SBF	C	2.86	3.00	2.50	2.45	2.10	1.75	3.83	4.08	3.48	3.43	2.98	2.54
EBS	6	5.71	5.63	4.61	4.15	3.28	2.97	7.67	7.66	6.40	5.82	4.66	4.32
EBS	7-1/2	7.75	7.64	6.26	5.28	4.18	3.78	10.4	10.4	8.68	7.41	5.93	5.49
EBS	10	9.54	9.63	7.25	6.72	5.56	4.64	12.8	13.2	10.0	9.42	7.88	6.74
EBS	13	13.6	14.0	10.2	9.54	8.00	6.15	18.3	19.0	14.2	13.4	11.4	8.94
O	9	9.69	9.24	7.24	6.11	5.31	4.43	13.0	12.6	10.1	8.57	7.53	6.44
O	12	13.3	12.6	9.91	9.74	8.46	7.06	17.8	17.2	13.8	13.6	12.0	10.3
O	21	21.4	20.4	14.3	11.7	10.1	8.46	28.8	27.8	19.8	16.4	14.4	12.3
O	30	30.8	32.3	23.0	17.5	15.2	12.7	41.4	44.0	32.0	24.5	21.5	18.4
O	35	35.7	37.4	26.7	19.0	16.5	13.8	47.9	51.0	37.0	26.6	23.4	20.0
O	45	45.9	48.1	34.3	21.9	19.0	15.9	61.6	65.6	47.6	30.7	26.9	23.1
V	38	38.7	39.4	33.6	33.2	30.5	24.1	52.0	53.7	46.6	46.6	43.2	35.1
V	50	52.0	52.9	45.1	47.4	43.5	34.4	69.8	72.1	62.6	66.5	61.7	50.0
V	70	71.4	72.6	62.7	66.4	60.9	48.1	95.8	99.0	87.0	93.1	86.4	70.0

VALVE TYPES	CARTRIDGE NO.	REPLACEABLE CARTRIDGE THERMOSTATIC EXPANSION VALVES												
Q-EQ-SQ	0	1/6	0.20	0.22	0.20	0.20	0.17	0.14	0.27	0.30	0.28	0.28	0.24	0.21
Q-EQ-SQ	1	1/4	0.46	0.49	0.46	0.45	0.39	0.32	0.62	0.66	0.64	0.63	0.55	0.47
Q-EQ-SQ	2	1/2	0.66	0.72	0.67	0.59	0.51	0.42	0.89	0.98	0.94	0.83	0.72	0.61
Q-EQ-SQ	3	1	1.02	1.07	0.89	0.85	0.73	0.61	1.37	1.46	1.24	1.19	1.03	0.88
Q-EQ-SQ	4	1-1/2	1.63	1.71	1.44	1.47	1.26	1.05	2.19	2.33	1.99	2.06	1.79	1.53
Q-EQ-SQ	5	2	2.14	2.25	1.88	1.96	1.68	1.40	2.88	3.06	2.61	2.74	2.38	2.04
Q-EQ-SQ	6	3	2.86	3.00	2.51	2.45	2.11	1.75	3.83	4.08	3.48	3.43	2.98	2.54

**BQ-EBQ-SBQ** Balanced port replaceable cartridges, AAA, AA, A, B and C, have the same capacities as the matching nominal capacity of the standard balanced port valves above.

REFRIGERANT	LIQUID TEMPERATURE ENTERING TEV °F														
	0°	10°	20°	30°	40°	50°	60°	70°	80°	90°	100°	110°	120°	130°	140°
	CORRECTION FACTOR, CF LIQUID TEMPERATURE														
404A	2.04	1.94	1.84	1.74	1.64	1.54	1.43	1.33	1.22	1.11	1.00	0.89	0.77	0.65	0.53
408A	1.66	1.60	1.54	1.47	1.40	1.34	1.27	1.21	1.14	1.07	1.00	0.93	0.86	0.79	0.71

These factors include corrections for liquid refrigerant density and net refrigerating effect and are based on an evaporator temperature of 0°F. However, they may be used for any evaporator temperature from -40°F to 40°F since the variation in the actual factors across this range is insignificant.

EVAPORATOR TEMPERATURE °F	PRESSURE DROP ACROSS TEV (psi)										
	30	50	75	100	125	150	175	200	225	250	275
	CORRECTION FACTOR, CF PRESSURE DROP										
40°	0.55	0.71	0.87	1.00	1.12	1.22	1.32	1.41	1.50	1.58	1.66
20° & 0°	0.49	0.63	0.77	0.89	1.00	1.10	1.18	1.26	1.34	1.41	1.48
-10° & -20°	0.45	0.58	0.71	0.82	0.91	1.00	1.08	1.15	1.22	1.29	1.35
-40°	0.41	0.53	0.65	0.76	0.85	0.93	1.00	1.07	1.13	1.20	1.25

**TEV Capacity = TEV Rating x CF Liquid Temperature x CF Pressure Drop** — Example: Actual capacity of a nominal 1-1/2 ton R-404A Type EG valve at -20°F evaporator, 125 psi pressure drop across the TEV, and 60°F liquid temperature entering the TEV = 1.26 (from rating chart) x 1.43 (CF liquid temperature) x 0.91 (CF pressure drop) = 1.64 tons.

# TEV CAPACITIES - TONS

# 402A, 507

## COMMERCIAL and LOW TEMPERATURE REFRIGERATION APPLICATIONS

VALVE TYPES	NOMINAL CAPACITY	REFRIGERANT											
		402A						507					
		RECOMMENDED THERMOSTATIC CHARGE											
		LC			LZ, LZP			PC			PZ, PZP		
EVAPORATOR TEMPERATURE °F													
		40°	20°	0°	-10°	-20°	-40°	40°	20°	0°	-10°	-20°	-40°
F-EF-G-EG	1/8	0.15	0.16	0.15	0.16	0.13	0.11	0.14	0.15	0.14	0.15	0.13	0.11
F-EF-G-EG	1/6	0.23	0.24	0.23	0.24	0.21	0.18	0.22	0.24	0.22	0.24	0.20	0.17
F-EF-G-EG	1/4	0.29	0.31	0.29	0.31	0.27	0.23	0.29	0.30	0.29	0.30	0.26	0.22
F-EF-G-EG	1/2	0.56	0.59	0.56	0.59	0.51	0.43	0.55	0.58	0.54	0.58	0.50	0.41
F-EF-G-EG	1	1.02	1.10	1.04	1.11	0.95	0.80	1.00	1.08	1.01	1.08	0.93	0.77
F-EF-G-EG	1-1/2	1.52	1.61	1.39	1.48	1.27	1.07	1.50	1.57	1.36	1.44	1.24	1.03
F&E(Ext)-G&EG(Ext)-S	2	2.03	2.14	1.84	1.97	1.70	1.42	2.00	2.09	1.79	1.92	1.65	1.38
S	3	2.85	3.00	2.52	2.47	2.12	1.78	2.79	2.93	2.45	2.40	2.06	1.72
S	4	4.07	4.28	3.60	3.45	2.97	2.49	3.99	4.19	3.50	3.36	2.89	2.41
S (Ext)	6	5.59	5.12	4.27	4.56	3.88	3.02	5.49	5.00	4.16	4.43	3.77	2.93
S (Ext)	7	7.12	6.51	5.44	5.81	4.95	3.85	6.99	6.36	5.30	5.65	4.80	3.73
H	3	2.85	2.72	2.32	2.46	2.10	1.68	2.79	2.66	2.26	2.40	2.04	1.63
H	4	4.07	3.89	3.15	3.45	2.94	2.36	3.99	3.81	3.07	3.36	2.86	2.28
H	6-1/2	6.61	6.33	5.12	5.36	4.57	3.66	6.49	6.18	4.98	5.22	4.44	3.54
H	9	9.66	9.25	7.48	6.16	5.25	4.20	9.48	9.04	7.28	5.99	5.09	4.07
H	12	13.2	12.7	10.2	9.86	8.40	6.73	13.0	12.4	10.0	9.59	8.16	6.52
M	15	16.1	17.1	13.1	13.9	12.5	10.2	15.8	16.7	12.7	13.5	12.1	9.83
M	20	20.9	22.3	16.4	17.4	15.7	12.7	20.6	21.8	16.0	16.9	15.2	12.3
M	25	26.1	27.8	20.5	20.4	18.4	14.9	25.6	27.2	20.0	19.9	17.9	14.5
M	30	31.5	33.5	24.7	23.6	21.3	17.3	30.9	32.8	24.1	23.0	20.7	16.7

### BALANCED PORT THERMOSTATIC EXPANSION VALVES

BF-EBF-SBF	AAA	0.23	0.24	0.23	0.24	0.21	0.18	0.23	0.24	0.22	0.24	0.21	0.17
BF-EBF-SBF	AA	0.46	0.49	0.46	0.45	0.39	0.33	0.45	0.48	0.45	0.44	0.38	0.32
BF-EBF-SBF	A	1.02	1.10	1.04	1.11	0.95	0.80	1.00	1.08	1.01	1.08	0.93	0.77
BF-EBF-SBF	B	1.88	1.98	1.66	1.61	1.39	1.16	1.85	1.94	1.62	1.57	1.35	1.12
BF-EBF-SBF	C	2.85	3.00	2.52	2.47	2.12	1.78	2.79	2.93	2.45	2.40	2.06	1.72
EBS	6	5.69	5.63	4.63	4.18	3.32	3.01	5.59	5.50	4.52	4.06	3.22	2.92
EBS	7-1/2	7.73	7.64	6.29	5.32	4.23	3.84	7.59	7.47	6.13	5.18	4.10	3.72
EBS	10	9.51	9.64	7.28	6.77	5.62	4.71	9.35	9.43	7.10	6.59	5.46	4.57
EBS	13	13.6	14.0	10.2	9.61	8.08	6.25	13.4	13.7	9.99	9.36	7.85	6.06
O	9	9.66	9.25	7.28	6.16	5.37	4.50	9.48	9.04	7.09	5.99	5.21	4.36
O	12	13.2	12.7	9.96	9.81	8.55	7.17	13.0	12.4	9.71	9.54	8.30	6.95
O	21	21.3	20.4	14.4	11.8	10.2	8.60	21.0	20.0	14.0	11.4	9.95	8.32
O	30	30.7	32.3	23.1	17.6	15.3	12.9	30.1	31.6	22.5	17.1	14.9	12.5
O	35	35.6	37.5	26.8	19.1	16.7	14.0	34.9	36.6	26.1	18.6	16.2	13.5
O	45	45.7	48.2	34.5	22.0	19.2	16.1	44.9	47.1	33.6	21.4	18.6	15.6
V	38	38.6	39.5	33.8	33.5	30.8	24.5	37.9	38.6	32.9	32.6	29.9	23.7
V	50	51.8	52.9	45.3	47.8	44.0	34.9	50.9	51.8	44.2	46.5	42.7	33.8
V	70	71.2	72.7	63.0	66.9	61.5	48.9	69.9	71.0	61.4	65.1	59.8	47.4

### REPLACEABLE CARTRIDGE THERMOSTATIC EXPANSION VALVES

VALVE TYPES	CARTRIDGE NO.													
Q-EQ-SQ	0	1/6	0.20	0.22	0.20	0.20	0.17	0.15	0.20	0.21	0.20	0.20	0.17	0.14
Q-EQ-SQ	1	1/4	0.46	0.49	0.46	0.45	0.39	0.33	0.45	0.48	0.45	0.44	0.38	0.32
Q-EQ-SQ	2	1/2	0.66	0.72	0.67	0.59	0.51	0.43	0.65	0.70	0.66	0.58	0.50	0.42
Q-EQ-SQ	3	1	1.02	1.07	0.89	0.86	0.74	0.62	1.00	1.05	0.88	0.83	0.72	0.60
Q-EQ-SQ	4	1-1/2	1.63	1.71	1.44	1.48	1.27	1.07	1.60	1.67	1.41	1.44	1.24	1.03
Q-EQ-SQ	5	2	2.14	2.25	1.88	1.97	1.70	1.43	2.10	2.20	1.84	1.92	1.65	1.38
Q-EQ-SQ	6	3	2.86	3.00	2.51	2.47	2.13	1.77	2.79	2.93	2.46	2.40	2.07	1.72

**BQ-EBQ-SBQ** Balanced port replaceable cartridges, AAA, AA, A, B and C, have the same capacities as the matching nominal capacity of the standard balanced port valves above.

REFRIGERANT	LIQUID TEMPERATURE ENTERING TEV °F														
	0°	10°	20°	30°	40°	50°	60°	70°	80°	90°	100°	110°	120°	130°	140°
402A	2.01	1.91	1.82	1.72	1.62	1.52	1.42	1.32	1.22	1.11	1.00	0.89	0.77	0.65	0.53
507	1.99	1.89	1.79	1.69	1.59	1.50	1.40	1.30	1.20	1.10	1.00	0.89	0.78	0.66	0.51

These factors include corrections for liquid refrigerant density and net refrigerating effect and are based on an evaporator temperature of 0°F. However, they may be used for any evaporator temperature from -40°F to 40°F since the variation in the actual factors across this range is insignificant.

EVAPORATOR TEMPERATURE °F	PRESSURE DROP ACROSS TEV (psi)										
	30	50	75	100	125	150	175	200	225	250	275
40°	0.55	0.71	0.87	1.00	1.12	1.22	1.32	1.41	1.50	1.58	1.66
20° & 0°	0.49	0.63	0.77	0.89	1.00	1.10	1.18	1.26	1.34	1.41	1.48
-10° & -20°	0.45	0.58	0.71	0.82	0.91	1.00	1.08	1.15	1.22	1.29	1.35
-40°	0.41	0.53	0.65	0.76	0.85	0.93	1.00	1.07	1.13	1.20	1.25

**TEV Capacity = TEV Rating x CF Liquid Temperature x CF Pressure Drop** — Example: Actual capacity of a nominal 1-1/2 ton R-404A Type EG valve at -20°F evaporator, 125 psi pressure drop across the TEV, and 60°F liquid temperature entering the TEV = 1.26 (from rating chart) x 1.43 (CF liquid temperature) x 0.91 (CF pressure drop) = 1.64 tons.

# TEV CAPACITIES - TONS

# 134a, 401A, 409A

## AIR CONDITIONING, HEAT PUMP and COMMERCIAL REFRIGERATION APPLICATIONS

VALVE TYPES	NOMINAL CAPACITY	REFRIGERANT								
		134a			401A			409A		
		RECOMMENDED THERMOSTATIC CHARGE								
		JC, JCP60			XC, XCP60			FC, FCP60		
EVAPORATOR TEMPERATURE °F										
40°    20°    0°    40°    20°    0°    40°    20°    0°										
F-EF-G-EG	1/8	0.15	0.15	0.14	0.16	0.16	0.15	0.15	0.15	0.14
F-EF-G-EG	1/6	0.25	0.28	0.26	0.27	0.30	0.29	0.25	0.28	0.27
F-EF-G-EG	1/4	0.31	0.35	0.33	0.34	0.37	0.36	0.32	0.35	0.33
F-EF-G-EG	1/2	0.60	0.60	0.55	0.65	0.65	0.60	0.61	0.60	0.56
F-EF-G-EG	1	1.20	1.20	1.10	1.29	1.29	1.20	1.21	1.21	1.12
F-EF-G-EG	1-1/2	1.93	1.91	1.76	2.07	2.07	1.92	1.94	1.93	1.79
F&EF(Ext)-G&EG(Ext)-S	2	2.41	2.39	2.20	2.59	2.59	2.40	2.42	2.42	2.23
S	2-1/2	3.01	2.99	2.75	3.23	3.24	3.00	3.03	3.02	2.79
S	3	3.62	3.59	3.30	3.88	3.88	3.60	3.63	3.62	3.35
S (Ext)	5	6.03	4.98	4.17	6.47	5.39	4.56	6.05	5.03	4.24
S (Ext)	6	7.23	5.98	5.01	7.76	6.47	5.47	7.26	6.04	5.09
H	3	3.62	3.59	3.04	3.88	3.88	3.31	3.63	3.62	3.08
H	4	4.82	4.79	4.05	5.18	5.18	4.42	4.84	4.83	4.11
H	5	6.03	5.98	5.06	6.47	6.47	5.52	6.05	6.04	5.14
H	8	9.04	8.97	7.59	9.70	9.71	8.29	9.08	9.06	7.71
H	12	14.1	14.0	11.8	15.1	15.1	12.9	14.2	14.1	12.0
M	15	18.7	18.5	15.1	20.1	20.1	16.5	18.8	18.7	15.3
M	20	24.1	23.9	19.5	25.9	25.9	21.3	24.2	24.2	19.8
M	25	30.1	29.9	24.3	32.3	32.4	26.6	30.3	30.2	24.7
BALANCED PORT THERMOSTATIC EXPANSION VALVES										
BF-EBF-SBF	AAA	0.25	0.28	0.26	0.27	0.30	0.29	0.25	0.28	0.27
BF-EBF-SBF	AA	0.54	0.54	0.50	0.58	0.58	0.54	0.55	0.54	0.50
BF-EBF-SBF	A	1.21	1.20	1.10	1.29	1.29	1.20	1.21	1.21	1.12
BF-EBF-SBF	B	2.05	2.03	1.87	2.20	2.20	2.04	2.06	2.05	1.90
BF-EBF-SBF	C	3.62	3.59	3.30	3.88	3.88	3.60	3.63	3.62	3.35
EBS	5	6.12	5.60	4.82	6.57	6.06	5.26	6.15	5.66	4.89
EBS	7	8.44	7.72	6.64	9.06	8.36	7.25	8.47	7.80	6.74
EBS	9	11.2	9.72	7.80	12.0	10.5	8.52	11.2	9.81	7.92
EBS	12	16.0	14.0	10.9	17.2	15.1	11.9	16.1	14.1	11.1
O	9	10.8	10.8	9.33	11.6	11.7	10.2	10.9	10.9	9.48
O	12	14.1	14.0	12.1	15.1	15.1	13.2	14.2	14.1	12.3
O	16	18.7	18.5	16.1	20.1	20.1	17.6	18.8	18.7	16.3
O	23	27.7	30.0	24.7	29.8	32.4	27.0	27.8	30.2	25.1
O	32	38.6	41.7	34.4	41.4	45.1	37.6	38.7	42.1	34.9
O	40	48.2	52.1	43.0	51.8	56.4	47.0	48.4	52.6	43.7
V	35	42.2	41.9	33.2	45.3	45.3	36.3	42.4	42.3	33.7
V	45	54.2	53.8	42.7	58.2	58.3	46.6	54.5	54.3	43.3
V	55	66.3	65.8	52.2	71.2	71.2	57.0	66.6	66.4	53.0
W	80	102	102	75.3	110	110	82.2	103	103	76.4
W	110	137	—	—	148	—	—	138	—	—
REPLACEABLE CARTRIDGE THERMOSTATIC EXPANSION VALVES										
Q-EQ-SQ	0	1/6	0.24	0.24	0.22	0.26	0.26	0.24	0.24	0.24
Q-EQ-SQ	1	1/4	0.54	0.54	0.50	0.58	0.58	0.54	0.55	0.54
Q-EQ-SQ	2	1/2	0.78	0.78	0.72	0.84	0.84	0.78	0.79	0.73
Q-EQ-SQ	3	1	1.21	1.20	1.10	1.29	1.29	1.20	1.21	1.12
Q-EQ-SQ	4	1-1/2	1.69	1.67	1.54	1.81	1.81	1.68	1.69	1.56
Q-EQ-SQ	5	2	2.41	2.39	2.20	2.59	2.59	2.40	2.42	2.23
Q-EQ-SQ	6	2-1/2	3.25	3.23	2.97	3.49	3.50	3.24	3.27	3.02
<b>BQ-EBQ-SBQ</b>	Balanced port replaceable cartridges, AAA, AA, A, B and C, have the same capacities as the matching nominal capacity of the standard balanced port valves above.									







REFRIGERANT	LIQUID TEMPERATURE ENTERING TEV °F														
	0°	10°	20°	30°	40°	50°	60°	70°	80°	90°	100°	110°	120°	130°	140°
	CORRECTION FACTOR, CF LIQUID TEMPERATURE														
134a	1.70	1.63	1.56	1.49	1.42	1.36	1.29	1.21	1.14	1.07	1.00	0.93	0.85	0.78	0.71
401A	1.60	1.54	1.48	1.43	1.36	1.31	1.25	1.19	1.13	1.06	1.00	0.94	0.87	0.80	0.74
409A	1.55	1.50	1.45	1.39	1.34	1.28	1.23	1.17	1.12	1.06	1.00	0.94	0.88	0.82	0.76

These factors include corrections for liquid refrigerant density and net refrigerating effect and are based on an evaporator temperature of 0°F. However, they may be used for any evaporator temperature from 0°F to 40°F since the variation in the actual factors across this range is insignificant.







EVAPORATOR TEMPERATURE °F	PRESSURE DROP ACROSS TEV (psi)							
	20	40	60	80	100	120	140	160
	CORRECTION FACTOR, CF PRESSURE DROP							
40°	0.58	0.82	1.00	1.15	1.29	1.41	1.53	1.63
20° & 0°	0.50	0.71	0.87	1.00	1.12	1.22	1.32	1.41

**TEV Capacity = TEV Rating x CF Liquid Temperature x CF Pressure Drop** — Example: Actual capacity of a nominal 1-1/2 ton R-134a Type EG valve at 20°F evaporator, 100 psi pressure drop across the TEV, and 60°F liquid temperature entering the TEV = 1.91 (from rating chart) x 1.29 (CF liquid temperature) x 1.12 (CF pressure drop) = 2.76 tons.







## ▼ TEV QUICK REFERENCE GUIDE

VALVE TYPE	SPECS	NOMINAL CAPACITY RANGE (Tons)				CONNECTION TYPES	VALVE DESCRIPTION AND APPLICATION
		R-22	R-134a	R-404A & R-507	R-410A		
<b>RC</b> 	Page 12	1 thru 6	–	–	1 thru 6	Chatleff, SAE Flare, or ODF Solder	Small brass body, externally adjustable valve available for R-22 and R-410A air conditioning and heat pump applications. This valve features a balanced port construction and contains an internal check valve to eliminate the need for an external bypass check valve on heat pump applications. Suitable for replacing OEM type TEVs with or without internal check valve on these applications.
<b>R</b> 	Page 13	1 thru 12	–	–	1 thru 15	ODF Solder	Small brass body, externally adjustable valve available for R-22 and R-410A air conditioning and heat pump applications. This valve features a balanced port construction and is approved for bi-directional operation. Suitable for replacing OEM type TEVs without internal check valve on these applications.
<b>RI</b> 	Page 14	2 thru 5	–	–	–	ODF Solder	Small brass bar body, externally adjustable valve available only for R-22 air conditioning or heat pump applications. This valve is provided with the Rapid Pressure Balancer (RPB) feature for off-cycle pressure equalization. Suitable for replacing OEM type TEVs used on these applications.
<b>F</b> 	Page 15 - 16	1/5 thru 3	1/8 thru 2	1/8 thru 2	–	SAE Flare	Small brass bar body, externally adjustable valve for small capacity refrigeration systems. SAE flare inlet connection has a removable 100 mesh strainer. Typical applications: Refrigerated cases, coolers, freezers.
<b>EF</b> 	Page 15 - 16	1/5 thru 3	1/8 thru 2	1/8 thru 2	–	ODF Solder	Same as the Type F valve except valve features ODF solder connections. The inlet connection has a 60 x 50 mesh insert type strainer. Typical applications: Refrigerated cases, coolers, freezers.
<b>Q/BQ</b> 	Page 17 - 19	<b>Q</b> 1/3 thru 5 <b>BQ</b> 1/8 thru 5-1/2	<b>Q</b> 1/6 thru 2-1/2 <b>BQ</b> 1/8 thru 3	<b>Q</b> 1/6 thru 3 <b>BQ</b> 1/8 thru 3	<b>Q</b> – <b>BQ</b> –	SAE Flare	The brass body Type Q valve is externally adjustable with a removable cartridge or orifice. The valve body, cartridge and thermostatic element is supplied as independent components. This allows body, cartridge and element to be assembled and matched to specific system requirements. Inlet connection has a 100 mesh removable strainer screen. Typical applications: Refrigeration applications and external equalized versions may be used on air conditioning. Type BQ same as above, with balanced port construction.
<b>EQ/EBQ</b> 	Page 17 - 19	<b>EQ</b> 1/3 thru 5 <b>EBQ</b> 1/8 thru 5-1/2	<b>EQ</b> 1/6 thru 2-1/2 <b>EBQ</b> 1/8 thru 3	<b>EQ</b> 1/6 thru 3 <b>EBQ</b> 1/8 thru 3	<b>EQ</b> – <b>EBQ</b> 1/4 thru 5-1/2	Extended ODF Solder	Type EQ same as the Type Q except it features extended ODF connections. A 100 mesh insert strainer is provided with the valve. Type EBQ same as Type EQ with balanced port construction and is approved for bi-directional applications.

## ▼ TEV QUICK REFERENCE GUIDE

VALVE TYPE	SPECS	NOMINAL CAPACITY RANGE (Tons)				CONNECTION TYPES	VALVE DESCRIPTION AND APPLICATION
		R-22	R-134a	R-404A & R-507	R-410A		
<b>SQ/SBQ</b> 	Page 19	<b>SQ</b> 1/3 thru 5  <b>SBQ</b> 1/8 thru 5-1/2	<b>SQ</b> 1/6 thru 2-1/2  <b>SBQ</b> 1/8 thru 3	<b>SQ</b> 1/6 thru 3  <b>SBQ</b> 1/8 thru 3	<b>SQ</b> –  <b>SBQ</b> 1/4 thru 5-1/2	Extended ODF Solder	Type SQ same as the Type Q valve except it features ODF solder connections and a forged brass inlet fitting with a removable 100 mesh strainer screen which can be cleaned and/or replaced without removing the valve from the line. Type SBQ is the same as Type SQ with balanced port construction and is approved for bi-directional applications.
<b>G</b> 	Page 20	1/5 thru 3	1/8 thru 2	1/8 thru 2	–	SAE Flare	Forged brass body, externally adjustable valve for small capacity refrigeration systems. Inlet connection has a removable 100 mesh strainer. Typical applications: Refrigerated cases, coolers, freezers, small capacity air conditioners.
<b>EG</b> 	Page 21	1/5 thru 3	1/8 thru 2	1/8 thru 2	–	ODF Solder	Same as the Type G valve except it features ODF solder connections and a forged brass inlet fitting with a removable 100 mesh strainer which can be cleaned and/or replaced without removing the valve from the line.
<b>BF</b> 	Page 22	1/8 thru 5-1/2	1/8 thru 3	1/8 thru 3	–	SAE Flare	Same physical size as the Type F valve with SAE flare connections except it features a balanced port construction. Inlet connection has a removable 100 mesh strainer. Typical applications: Small capacity refrigeration that operates over widely varying operating conditions.
<b>SBF</b> 	Page 23	1/8 thru 5-1/2	1/8 thru 3	1/8 thru 3	–	Extended ODF Solder	Same as the Type BF valve except it features ODF solder connections and a forged brass inlet fitting with a removable 100 mesh strainer which can be cleaned and/or replaced without removing the valve from the line.
<b>EBF</b> 	Page 23	1/8 thru 5-1/2	1/8 thru 3	1/8 thru 3	–	Extended ODF Solder	Same as the Type BF valve except it features extended ODF connections. A 100 mesh insert strainer is provided with the valve.
<b>S</b> 	Page 24	2 thru 10	2 thru 6	2 thru 7	–	ODF Solder	Brass bar body, externally adjustable valve. Inlet has a permanent 12 mesh strainer. General purpose valve for air conditioning and refrigeration applications.

## ▼ TEV QUICK REFERENCE GUIDE

VALVE TYPE	SPECS	NOMINAL CAPACITY RANGE (Tons)				CONNECTION TYPES	VALVE DESCRIPTION AND APPLICATION
		R-22	R-134a	R-404A & R-507	R-410A		
<b>EBS</b> 	Page 25	8 thru 20	5 thru 12	6 thru 13	—	Extended ODF Solder	Same physical size and inlet strainer as the Type S valve except it features extended ODF connections. This valve features a balanced port construction which, depending on its capacity, makes it suitable for bi-directional operation. See page 28 for details.
<b>O</b> 	Page 26-27	15 thru 70	9 thru 40	9 thru 45	20 thru 60	ODF Solder	Brass bar body, externally adjustable valve. Inlet has a permanent 12 mesh strainer. This valve features a balanced port construction, and it is suitable for both air conditioning and refrigeration applications. Optional bi-directional feature available, please contact Sporlan Division of Parker for details.
<b>H</b> 	Page 28	5-1/2 thru 20	3 thru 12	3 thru 12	—	ODF Solder or FPT Flange	Brass bar body, externally adjustable valve with flange connections. Inlet flange bushing has a permanent 16 mesh strainer. The FPT flange connection requires the K-1178 adapter kit. This valve provides the smallest capacity TEVs with flange connections and it is suitable for both air conditioning and refrigeration applications.
<b>M</b> 	Page 28	21 thru 42	15 thru 25	15 thru 30	—	ODF Solder or FPT Flange	Cast bronze body, externally adjustable valve with flange connections. Inlet has a 12 mesh strainer. This valve type provides valve capacities greater than the Type H and it is suitable for air conditioning and refrigeration applications. Flanges for the Type M valve are interchangeable with the Type V valve.
<b>V</b> 	Page 29	52 thru 100	35 thru 55	38 thru 70	—	ODF Solder or FPT Flange	Cast bronze body, externally adjustable valve with flange connections. Inlet has a 12 mesh strainer. This valve type features a dual port semi-balanced design. This valve type provides valve capacities greater than the Type M and is suitable for air conditioning and refrigeration applications. Flanges for the Type V are interchangeable with the Type M.
<b>W</b> 	Page 29	135 & 180	80 & 110	—	—	ODF Solder Flange	Cast bronze body, externally adjustable valve with flange connections. Inlet has a 12 mesh strainer. This valve type features a dual port semi-balanced design and it is primarily for large capacity chillers. This valve type provides the largest valve capacities available for flange connection TEVs.

# ▼ TYPE RC

For Refrigerants 22, 410A  
Chatleff, SAE Flare & ODF Solder Connections

Sporlan Type RC valve is a small brass body, externally adjustable valve with balanced port construction. The RC valves are available for replacement of types CBI and CBBI valves. These valves contain internal check valves to allow reverse flow on heat pump applications. This eliminates the need for an external check valve piped around the TEV for reverse flow. The RC valve can be used on heat pump and air conditioning (cooling only) applications. This allows you to reduce inventory by using the same valve

to replace the I, BI and BBI valves. The RC valves can even be used to replace the RI valve (non-RPB versions only).

**Outlet Connections**  
1/2" SAE, 1/2" ODF, 5/8" ODF

**Mating Distributors (See Bulletin 20-10)**  
D260, D262, 1603, 1605, 1606, 1608, 1620, 1622, 1650(R), 1651(R)

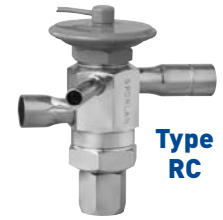

Type RC

## Specifications – Element Size No. 43 (R-22) And No. 45 (R-410A), Knife Edge Joint

REFRIGERANT (Sporlan Code)	VALVE TYPE	EXTERNAL EQUALIZER ②, ③	NOMINAL CAPACITY Tons of Refrigeration	THERMOSTATIC ELEMENT SIZE NO.	THERMOSTATIC CHARGES AVAILABLE	STANDARD TUBING LENGTH Inches	CONNECTIONS - Inches ① SAE Flare/④ ODF Solder  Blue figures are standard and will be furnished unless otherwise specified.		NET WEIGHT - lbs.	SHIPPING WEIGHT - lbs.
							INLET	OUTLET		
<b>22 (V)</b> 407C (N) 407A (V) 422D (V)	RCVE-1-GA	1/4 SAE 1/4 ODF	1	43	VGA	30	3/8 SAE 3/8 ODF	1/2 SAE	1-1/4	1-1/2
	RCVE-1-1/2-GA		1-1/2					1/2 ODF		
	RCVE-2-GA		2					1/2 SAE		
	RCVE-3-GA		3					1/2 ODF		
	RCVE-4-GA		4					1/2 SAE		
	RCVE-5-GA		5					5/8 ODF		
RCVE-6-GA	6									
<b>410A (Z)</b>	RCZE-1-GA	1/4 ODF	1	45	ZGA	30	3/8 ODF	1/2 ODF	1-1/4	1-1/2
	RCZE-1-1/2-GA		1-1/2					1/2 ODF		
	RCZE-2-GA		2					1/2 ODF		
	RCZE-3-GA		3					1/2 ODF		
	RCZE-4-GA		4					1/2 ODF		
	RCZE-5-GA		5					5/8 ODF		
RCZE-6-GA	6									

① Valves are also available as special order with Chatleff connections.  
 ② Valves with SAE inlet and outlet fittings are available only with the 1/4" SAE flare external equalizer; valves with ODF fittings are available only with the 1/4" ODF external equalizer.  
 ③ Valves with Chatleff fittings are available only with the 1/8" OD X 24" long tube with flare and nut external equalizer.  
 ④ ODF Solder on Type RC valves indicates a female connection on the valve of proper diameter to receive copper tubing of corresponding OD size. Thus 1/2" ODF will receive 1/2" OD tubing.

## Dimensions – CONNECTIONS - Inches

VALVE TYPE	FITTING SIZE	A	B	C	D
RC	3/8 SAE	1.92	-	-	1.63
	1/2 SAE	1.89	1.92	-	1.63
	3/8 ODF	1.92	1.45	0.31	1.90
	1/2 ODF	1.98	1.45	0.40	1.90
	5/8 ODF	-	1.53	0.50	1.90
RC Chatleff Fitting		1.89	1.71	-	③

## Bulb Sizes - Inches

STANDARD CHARGES	REFRIGERANT	
	22	410A
GA	0.75 OD x 2.00	

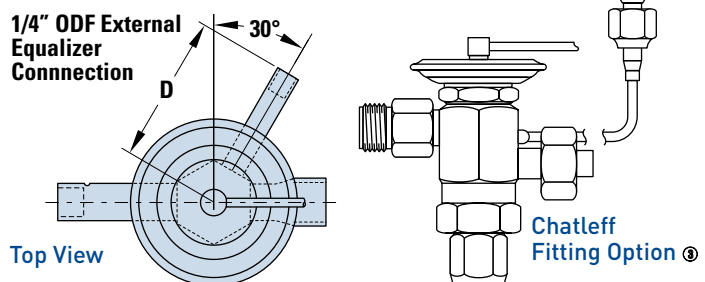
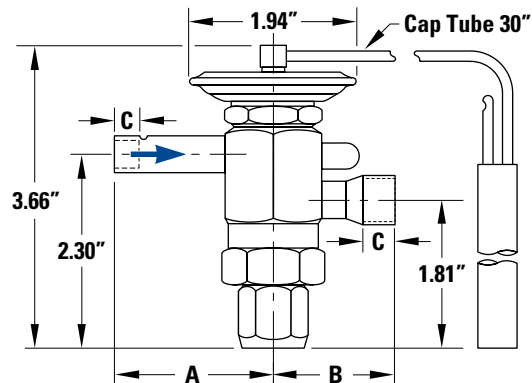

# ▼ TYPE R

For Refrigerants 22, 410A  
ODF Solder Connections

Sporlan Type R valve is a small brass bar body, externally adjustable with ODF solder connections, a replaceable thermostatic element, and balanced port construction. The R valve is designed for R-22 and R-410A air conditioning and heat pump applications and is ideal for replacing I, BI, BBI and RI (non-RPB version only) valves.

This valve type has two body styles: a small body which provides capacities up to 8 tons R-22 and R-410A, and a large body style which extends capacities to 12 tons R-22 and 15 tons R-410A.

Replacement elements available for these valves are the following: Refrigerant R-22, Element Kit Number KT-43-VGA or VCP100 for the small

body style and KT-45-5-VGA or VCP100 for the large body, and Refrigerant R-410A, Element Kit Number KT-45-ZGA or ZCP200 for the small body style and KT-45-5-ZGA or ZCP200 for the large body style.

This valve may also be applied in bi-directional applications.

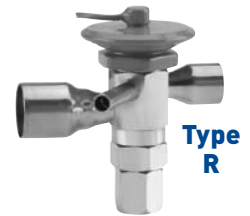

### Outlet Connections

1/2" ODF, 5/8" ODF, 7/8" ODF, 1-1/8" ODF

### Mating Distributors (See Bulletin 20-10)

D260, D262, 1620, 1622, 1112, 1113, 1115, 1116, 1135, 1136, 1137, 1651(R), 1653(R), 1655(R)

## Specifications – Element Size No. 43 (R-22), No. 45 (R-410a), And No. 45-5, Knife Edge Joint

REFRIGERANT (Sporlan Code)	VALVE TYPE	NOMINAL CAPACITY Tons of Refrigeration	THERMOSTATIC ELEMENT SIZE NO.	THERMOSTATIC CHARGES AVAILABLE	STANDARD TUBING LENGTH Inches	CONNECTIONS - Inches ②		NET WEIGHT - lbs.	SHIPPING WEIGHT - lbs.				
						① ODF Solder Blue figures are standard and will be furnished unless otherwise specified.							
						INLET	OUTLET						
<b>22 (V)</b> 407C (N) 407A (V) 422D (V)	RVE-1	1	43	VGA VCP100	30	3/8	3/8, 1/2 or 5/8	1	1-1/2				
	RVE-1-1/2	1-1/2				3/8 or 1/2	1/2, 5/8 or 7/8						
	RVE-2	2				3/8, 1/2 or 5/8							
	RVE-3	3											
	RVE-4	4											
	RVE-5	5											
	RVE-6	6			60	3/8, 1/2 or 5/8	1/2, 5/8 or 7/8						
	RVE-8	8				3/8, 1/2 or 5/8	1/2, 5/8 or 7/8						
	RVE-10	10				1/2, 5/8 or 7/8	5/8, 7/8, or 1-1/8						
	RVE-12	12				1-1/4							
	<hr/>												
	<b>410A (Z)</b>	RZE-1				1	45	ZGA ZCP200	30	3/8	3/8, 1/2 or 5/8	1	1-1/2
RZE-1-1/2		1-1/2	3/8 or 1/2	1/2, 5/8 or 7/8									
RZE-2		2	3/8, 1/2 or 5/8										
RZE-3		3											
RZE-4		4											
RZE-5		5			60	3/8, 1/2 or 5/8				1/2, 5/8 or 7/8			
RZE-6		6	3/8, 1/2 or 5/8	1/2, 5/8 or 7/8									
RZE-8		8	3/8, 1/2 or 5/8	1/2, 5/8 or 7/8									
RZE-12-1/2		12-1/2	1/2, 5/8 or 7/8	5/8, 7/8, or 1-1/8									
RZE-15		15	1-1/4										

① ODF Solder indicates a female connection on the valve of proper diameter to receive copper tubing of corresponding OD size. Thus 1/2" ODF will receive 1/2" OD tubing.

② Minimum quantities may apply to non-standard connections. Not all connection combinations are available.

## Dimensions – CONNECTIONS - Inches

VALVE TYPE	FITTING SIZE	A	B	C	D	E	F	G
RVE & RZE 1, 1-1/2 & 2*	3/8 ODF	1.69	1.35	0.31	1.81	2.17	3.53	1.83
	1/2 ODF	1.75*	1.35	0.40				
	5/8 ODF	—	1.43	0.50				
RVE & RZE 3, 4, 5, 6 & 8	3/8 ODF	1.69	—	0.31	1.90	2.30	3.79	1.83
	1/2 ODF	1.75	1.35	0.40				
	5/8 ODF	1.29	2.51	0.50				
	7/8 ODF	—	2.41	0.78				
RVE-10 & 12 RZE-12-1/2 & 15	5/8 ODF	1.52	—	0.50	1.90	2.30	3.79	1.83
	7/8 ODF	2.08	—	0.78				
	5/8 ODF Ext.	—	2.51	0.50				
	7/8 ODF Ext.	—	2.51	0.78				
	1-1/8 ODF Ext.	—	2.51	0.91				

\* 1/2 ODF inlet available on 2 ton valves only.

1/4" ODF  
External  
Equalizer  
Connection

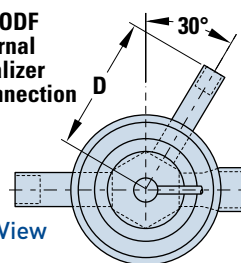

Top View

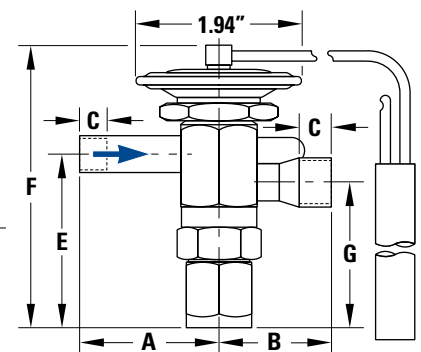

## Bulb Sizes - Inches

STANDARD CHARGES	REFRIGERANT	
	22	410A
VCP100, ZCP200	0.50 OD x 3.00	
GA	0.75 OD x 2.00	

## ▼ TYPE RI WITH RAPID PRESSURE BALANCE (RPB)

For Refrigerant 22  
ODF Solder Connections

Sporlan Type RI valve is a small brass bar body, externally adjustable valve available with ODF solder connections, and a replaceable thermostatic element. The RIVE valve is designed for small R-22 air conditioning and heat pump units with limited space and which require the Rapid Pressure Balancer (RPB) feature for off-cycle pressure equalization. This valve is also ideal for replacement of OEM type Sporlan TEVs such as the Type I when used on the above applications.

Refer to Sporlan Bulletin 10-9 for additional information on this subject.

**Outlet Connections**  
1/2" ODF, 5/8" ODF

**Mating Distributors (See Bulletin 20-10)**  
D260, D262, 1620, 1622, 1651(R)



### Specifications – Element Size No. 43, Knife Edge Joint

REFRIGERANT (Sporlan Code)	VALVE TYPE External Equalizer Only	NOMINAL CAPACITY Tons of Refrigeration	THERMOSTATIC CHARGES AVAILABLE	STANDARD TUBING LENGTH Inches	CONNECTIONS - Inches ① ODF Solder Blue figures are standard and will be furnished unless otherwise specified.		NET WEIGHT - lbs.	SHIPPING WEIGHT - lbs.
					INLET	OUTLET		
<b>22 (V)</b> 407C (N) 407A (V) 422D (V)	RIVE-2	2	GA	30	3/8	1/2	1	1-1/2
	RIVE-3	3				1/2		
	RIVE-4	4			1/2	5/8		
	RIVE-5	5			1/2	5/8		

① ODF Solder indicates a female connection on the valve of proper diameter to receive copper tubing of corresponding OD size. Thus 1/2" ODF will receive 1/2" OD tubing.

② The Nominal Capacity of the valve is increased by 15% when the Rapid Pressure Balancer (RPB) feature is used. A cross drilling is part of the internal construction of the RPB feature and this drilling provides the additional refrigerant flow.

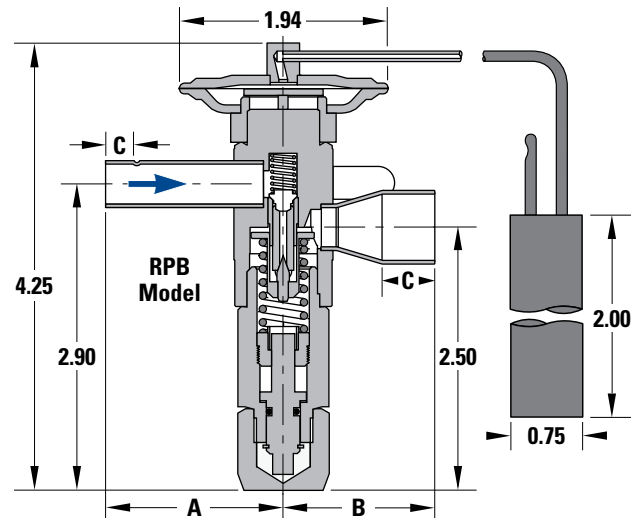
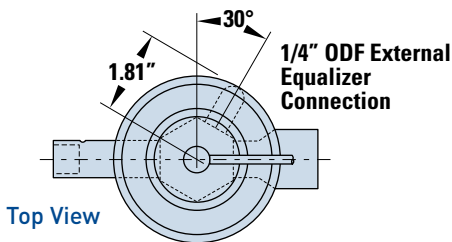

### Dimensions – CONNECTIONS - Inches

FITTING SIZE	A	B	C
3/8 ODF	1.69	–	0.31
1/2 ODF	1.75	1.35	0.40
5/8 ODF	–	1.45	0.50

# ▼ TYPE F & EF

For Refrigerants 22, 134a, 404A, 507  
SAE Flare & ODF Solder Connections

Sporlan Type F with SAE flare connections or Type EF with ODF solder connections are small brass bar body valves with identical internal construction and replaceable thermostatic elements. The Type F valve has a removable 100 mesh strainer as a standard feature. The Type EF has a 60 x 50 mesh insert strainer. These valves are designed for small refrigeration systems such as refrigerated cases, coolers, and

freezers where space is limited and an external adjustment is desired.

### Outlet Connections

3/8" SAE, 1/2" SAE, 3/8" ODF, 1/2" ODF

### Mating Distributors (See Bulletin 20-10)

D260, D262, 1603, 1605, 1606, 1608, 1650(R)

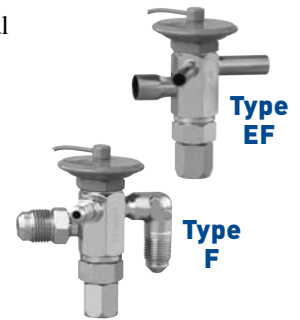

## Specifications – Element Size No. 43, Knife Edge Joint

REFRIGERANT (Sporlan Code)	TYPE F		TYPE EF		NOMINAL CAPACITY Tons of Refrigeration	THERMOSTATIC CHARGES AVAILABLE	STANDARD TUBING LENGTH Inches	CONNECTIONS - Inches SAE Flare / ② ODF Solder		NET WEIGHT - lbs.	SHIPPING WEIGHT - lbs.
	SAE Flare		ODF Solder					INLET	OUTLET		
	Internal Equalizer	External Equalizer	Internal Equalizer	External Equalizer							
<b>22 (V)</b> 407C (N) 407A (V) 422D (V)	FV-1/5	FVE-1/5	EFV-1/5	EFVE-1/5	1/5	C Z ZP40	30	1/4 or 3/8 ①	3/8 or 1/2	1	1-1/2
	FV-1/3	FVE-1/3	EFV-1/3	EFVE-1/3	1/3						
	FV-1/2	FVE-1/2	EFV-1/2	EFVE-1/2	1/2						
	FV-1	FVE-1	EFV-1	EFVE-1	1						
	FV-1-1/2	FVE-1-1/2	EFV-1-1/2	EFVE-1-1/2	1-1/2						
	–	FVE-2	–	EFVE-2	2						
	FV-2-1/2	–	EFV-2-1/2	–	2-1/2						
–	–	–	EFVE-3	3							
<b>134a (J)</b> 12 (F) 401A (X) 409A (F)	FJ-1/8	FJE-1/8	EFJ-1/8	EFJE-1/8	1/8	C	30	1/4 or 3/8 ①	3/8 or 1/2	1	1-1/2
	FJ-1/6	FJE-1/6	EFJ-1/6	EFJE-1/6	1/6						
	FJ-1/4	FJE-1/4	EFJ-1/4	EFJE-1/4	1/4						
	FJ-1/2	FJE-1/2	EFJ-1/2	EFJE-1/2	1/2						
	FJ-1	FJE-1	EFJ-1	EFJE-1	1						
	FJ-1-1/2	FJE-1-1/2	EFJ-1-1/2	EFJE-1-1/2	1-1/2						
	–	FJE-2	–	EFJE-2	2						
<b>404A (S)</b> 502 (R) 408A (R)	FS-1/8	FSE-1/8	EFS-1/8	EFSE-1/8	1/8	C Z ZP40	30	1/4 or 3/8 ①	3/8 or 1/2	1	1-1/2
	FS-1/6	FSE-1/6	EFS-1/6	EFSE-1/6	1/6						
	FS-1/4	FSE-1/4	EFS-1/4	EFSE-1/4	1/4						
	FS-1/2	FSE-1/2	EFS-1/2	EFSE-1/2	1/2						
	FS-1	FSE-1	EFS-1	EFSE-1	1						
	FS-1-1/2	FSE-1-1/2	EFS-1-1/2	EFSE-1-1/2	1-1/2						
	–	FSE-2	–	EFSE-2	2						
<b>507 (P)</b> 402A (L)	FP-1/8	FPE-1/8	EFP-1/8	EFPE-1/8	1/8	C Z ZP40	30	1/4 or 3/8 ①	3/8 or 1/2	1	1-1/2
	FP-1/6	FPE-1/6	EFP-1/6	EFPE-1/6	1/6						
	FP-1/4	FPE-1/4	EFP-1/4	EFPE-1/4	1/4						
	FP-1/2	FPE-1/2	EFP-1/2	EFPE-1/2	1/2						
	FP-1	FPE-1	EFP-1	EFPE-1	1						
	FP-1-1/2	FPE-1-1/2	EFP-1-1/2	EFPE-1-1/2	1-1/2						
	–	FPE-2	–	EFPE-2	2						

① The 3/8" SAE inlet fitting has a long taper on the flare surface. A 3/8" x 1/4" reducing flare nut will allow 1/4" OD tubing to be attached to this fitting.

② ODF Solder on Type EF valves indicates a female connection on the valve of proper diameter to receive copper tubing of corresponding OD size. Thus 1/2" ODF will receive 1/2" OD tubing.

③ Nominal 1 ton and larger F valves for R-134a, R-404A and R-507 type refrigerants, and nominal 1-1/2 ton and larger for R-22 refrigerant require 3/8" SAE Flare or 3/8" ODF inlet, minimum.

# ▼ TYPE F & EF

For Refrigerants 22, 134A, 404A, 507  
SAE Flare & ODF Solder Connections

## SAE FLARE

### Dimensions - ODF CONNECTIONS - Inches

FITTING SIZE	A	B	C
1/4 SAE Elbow	1.05	–	1.34
3/8 SAE Elbow	1.27	–	0.98
3/8 SAE	–	1.61	–
1/2 SAE	–	1.80	–

### Bulb Sizes - Inches

STANDARD CHARGES	REFRIGERANT			
	22	134a	404	507
C	0.50 OD x 3.00			
Z & ZP Series	0.50 OD x 3.00	–	0.50 OD x 3.00	

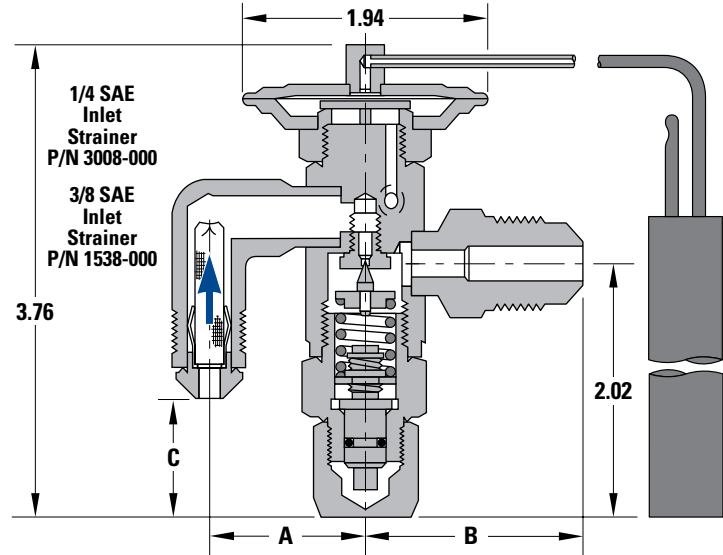
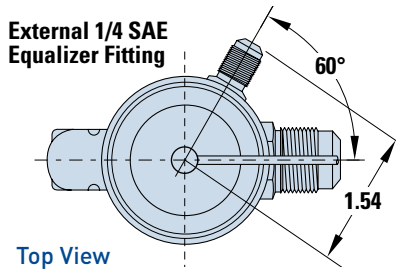

## ODF SOLDER

### Dimensions - ODF CONNECTIONS - Inches

FITTING SIZE	A	B	C
1/4 ODF	1.69	–	0.31
3/8 ODF	1.69	1.35	0.31
1/2 ODF	–	1.35	0.40

### Bulb Sizes - Inches

STANDARD CHARGES	REFRIGERANT			
	22	134a	404	507
C	0.50 OD x 3.00			
Z & ZP Series	0.50 OD x 3.00	–	0.50 OD x 3.00	

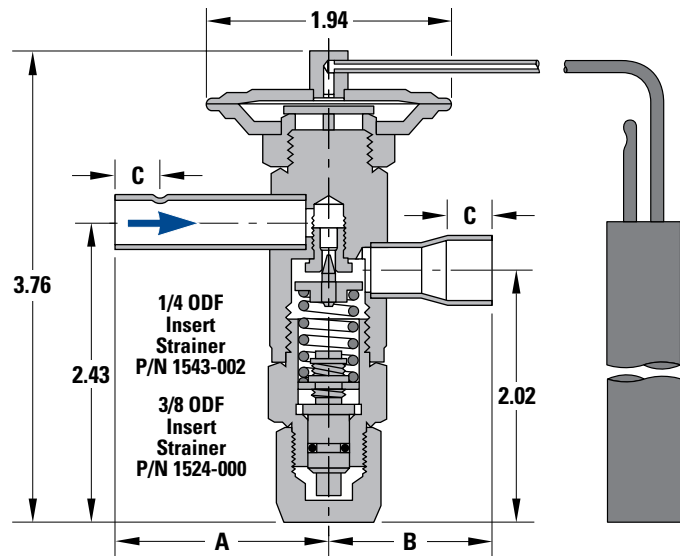
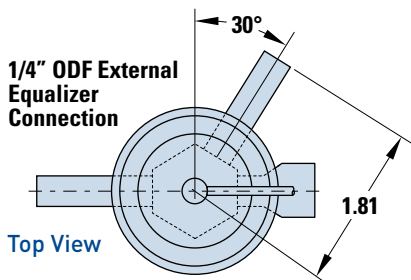

# ▼ TYPE Q & BQ

For Refrigerants 22, 134a, 404A, 410A\*, 507  
SAE Flare & Extended ODF Solder Connections

The Sporlan Q & BQ series are replaceable cartridge style valves designed for small refrigeration systems, such as refrigerated cases, coolers, and freezers. The externally equalized versions of these valves are ideal for air conditioning and heat pump systems. BQ valves are balanced ported, engineered specifically for systems with a wide range of operating conditions and may be applied on bi-directional applications.

Q & BQ valves are supplied as three individual component parts: the **thermostatic element**, the **valve body**, and the **replaceable cartridge** or orifice. The interchangeable nature of the Q & BQ family make it ideal for reducing inventory, while increasing valve options — so, the right valve is always on hand.

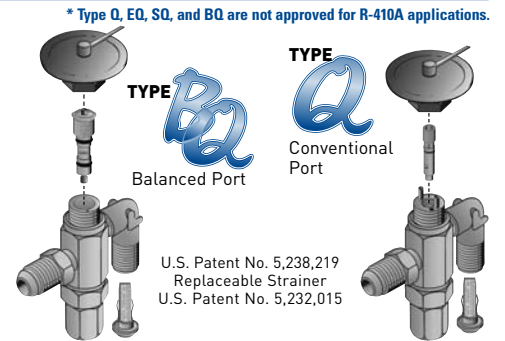

NOMINAL CAPACITY (TONS) of SPORLAN VALVE TO BE REPLACED										CARTRIDGE		CARTRIDGE and I.D. TAG		
	R-12	R-22, R-422D	R-134a	R-401A	R-402A	R-404A	R-410A	R-502	R-507	SIZE	COLOR CODE	PART NUMBER		
<b>Q CAPACITIES</b>	1/8	1/4	1/8	1/8	1/8	1/8	<b>NOT APPROVED</b>	1/8	1/8	0	Red	QC-0		
	1/6	1/3	1/6	1/6	1/6	1/6		1/6						
	1/4	1/2	1/4	1/4	1/4	1/4		1/4	1/2	1/2	1	Yellow	QC-1	
		3/4												
	1/2	1	1/2	1/2	1/2	1/2		1/2	1/2	1/2	2	Green	QC-2	
	1	1-1/2	1	1	1	1		1	1	1	3	Blue	QC-3	
	1-1/2	2	1-1/2	1-1/2	1-1/2	1-1/2		1-1/2	1-1/2	1-1/2	1-1/2	4	Pink	QC-4
		2-1/2												
2	3	2	2	2	2	2	2	2	5	Black	QC-5			
2-1/2	4	2-1/2	2-1/2	3	3	3	3	3	3	6	White	QC-6		
3	5	3	3											
<b>BQ CAPACITIES</b>	1/8 thru 1/5	1/8 thru 1/3	1/8 thru 1/5	1/8 thru 1/5	1/8 thru 1/5	1/8 thru 1/5	1/4 thru 1/3	1/8 thru 1/5	1/8 thru 1/5	AAA	Red	BQC-AAA		
	1/4 thru 1/3	1/2 thru 2/3	1/4 thru 1/3	1/4 thru 1/3	1/4 thru 1/3	1/4 thru 1/3	1/2 thru 3/4	1/4 thru 1/3	1/4 thru 1/3	AA	Yellow	BQC-AA		
	1/2 thru 1	3/4 thru 1-1/2	1/2 thru 1	1/2 thru 1	1/2 thru 1	1/2 thru 1	1 thru 1-3/4	1/2 thru 1	1/2 thru 1	A	Blue	BQC-A		
	1-1/4 thru 1-3/4	1-3/4 thru 3	1-1/4 thru 1-3/4	1-1/4 thru 1-3/4	1-1/4 thru 2	1-1/4 thru 2	2 thru 3-1/2	1-1/4 thru 2	1-1/4 thru 2	B	Pink	BQC-B		
	2 thru 3	3-1/4 thru 5-1/2	2 thru 3	2 thru 3	2-1/4 thru 3	2-1/4 thru 3	4 thru 6	2-1/4 thru 3	2-1/4 thru 3	C	White	BQC-C		

BQ Cartridges also available with optional 15% bleed.

## Recommended Thermostatic Elements\*\*

APPLICATION	REFRIGERANT												THERMOSTATIC ELEMENT	SYSTEM MOP psig	
	12	22, 422D	134a	401A	402A	404A	407A	407C	408A	409A	410A	502			507
Air Conditioning	X	-	X	X	-	-	-	-	-	X	-	-	-	KT-43-FCP60	50
	-	X	-	-	-	-	X	X	-	-	-	-	-	KT-43-FVCP100	90
	-	X	-	-	-	-	X	X	-	-	-	-	-	KT-43-VGA	-
	-	-	-	-	-	X	-	-	X	-	-	X	-	KT-43-RCP115	105
	-	-	-	-	-	-	-	-	-	-	X	-	-	KT-45-ZGA	-
Commercial Refrigeration 50°F to -10°F	X	-	X	X	-	-	-	-	-	X	-	-	-	KT-43-FC	-
	-	X	-	-	-	-	X	X	-	-	-	-	-	KT-43-VC	-
	-	-	-	-	-	X	-	-	X	-	-	X	-	KT-43-RC	-
	-	-	-	-	X	-	-	-	-	-	-	X	-	KT-43-PC	-
Low Temperature Refrigeration 0°F to -40°F	X	-	-	-	-	-	-	-	-	-	-	-	-	KT-43-FZ	-
	X	-	-	-	-	-	-	-	-	-	-	-	-	KT-43-FZP	12
	-	X	-	-	-	-	-	-	-	-	-	-	-	KT-43-VZ	-
	-	X	-	-	-	-	-	-	-	-	-	-	-	KT-43-VZP40	30
	-	-	-	-	X	X	-	-	X	-	-	X	X	KT-43-RZ	-
-	-	-	-	X	X	-	-	X	-	-	X	X	KT-43-RZP	35	

- \*\*APPLICATION FACTORS:**
- The Sporlan Type ZP thermostatic charges have essentially the same characteristics as the conventional Z cross charges with one exception: they produce a pressure limit or MOP. The ZP charges are not intended as replacements for the Z charges - they should only be used where a definite pressure limit is required to prevent motor overloading.
  - All air conditioning and heat pump charges are intended for use with externally equalized valves.
  - For dual temperature applications, use the "C" charge.
  - The "C" charge may be used on applications down to -30°F on R-22, R-404A and R-507.
  - R-410A elements for use with SBQ and EBQ only.

## Nomenclature/Ordering Instructions

BODY	CARTRIDGE	ELEMENT
<b>(B)QE</b> Valve Type <b>(B)Q, E(B)Q, S(B)Q</b> Internally Equalized <b>(B)QE, E(B)QE, S(B)QE</b> Externally Equalized	<b>3/8 x 1/2 x 1/4 SAE</b> Connection Size and Style: Inlet x Outlet x External Equalizer	<b>BQC</b> - Cartridge Type <b>AA</b> - Cartridge Size <b>KT-43</b> - Element Kit <b>V</b> - Refrigerant Code (See above) <b>C</b> - Thermostatic Charge <b>5'</b> - Capillary Tube Length

▼ TYPE Q & BQ

For Refrigerants 22, 134a, 404A, 410A\*, 507  
SAE Flare & Extended ODF Solder Connections

\* Type Q, EQ, SQ, and BQ are not approved for R-410A applications.

Q Specifications – Element Size No. 43, Knife Edge Joint

REFRIGERANT (Sporlan Code)	BODY TYPE - CARTRIDGE						CARTRIDGE	NOMINAL CAPACITY Tons of Refrigeration	THERMOSTATIC CHARGES AVAILABLE	STANDARD TUBING LENGTH Feet	CONNECTIONS Inches Blue figures are standard and will be furnished unless otherwise specified.	NET WEIGHT - lbs.	SHIPPING WEIGHT - lbs.
	SAE Flare		Extended ODF Solder										
	Internal Equalizer ①	External Equalizer ②	Internal Equalizer ①	External Equalizer ②	Internal Equalizer ①	External Equalizer ②							
22 (V) 407C (N) 407A (V) 422D (V)	Q-0	QE-0	EQ-0	EQE-0	SQ-0	SQE-0	0	1/3	Refer to Recommended Thermostatic Elements on Page 17	5	Q & QE Only 1/4 x 3/8 SAE 90° Angle Inlet or 1/4 x 1/2 SAE 90° Angle Inlet or 3/8 x 1/2 SAE 90° Angle Inlet  EQ Only 3/8 x 1/2 ODF Straight Thru  EQE Only 3/8 x 1/2 ODF Straight Thru or 3/8 x 5/8 ODF Straight Thru or 1/2 x 5/8 ODF Straight Thru or 1/2 x 7/8 ODF Straight Thru  SQ & SQE Only 3/8 x 1/2 ODF 90° Angle Inlet	1	1-1/2
	Q-1	QE-1	EQ-1	EQE-1	SQ-1	SQE-1	1	3/4					
	Q-2	QE-2	EQ-2	EQE-2	SQ-2	SQE-2	2	1					
	Q-3	QE-3	EQ-3	EQE-3	SQ-3	SQE-3	3	1-1/2					
	Q-4	QE-4	EQ-4	EQE-4	SQ-4	SQE-4	4	2-1/2					
	Q-5	QE-5	EQ-5	EQE-5	SQ-5	SQE-5	5	3-1/2					
	Q-6	QE-6	EQ-6	EQE-6	SQ-6	SQE-6	6	5					
134a (J) 12 (F) 401A (X) 409A (F)	Q-0	QE-0	EQ-0	EQE-0	SQ-0	SQE-0	0	1/6					
	Q-1	QE-1	EQ-1	EQE-1	SQ-1	SQE-1	1	1/4					
	Q-2	QE-2	EQ-2	EQE-2	SQ-2	SQE-2	2	1/2					
	Q-3	QE-3	EQ-3	EQE-3	SQ-3	SQE-3	3	1					
	Q-4	QE-4	EQ-4	EQE-4	SQ-4	SQE-4	4	1-1/2					
	Q-5	QE-5	EQ-5	EQE-5	SQ-5	SQE-5	5	2					
	Q-6	QE-6	EQ-6	EQE-6	SQ-6	SQE-6	6	2-1/2					
404A (S) 502 (R) 408A (R)	Q-0	QE-0	EQ-0	EQE-0	SQ-0	SQE-0	0	1/6					
	Q-1	QE-1	EQ-1	EQE-1	SQ-1	SQE-1	1	1/4					
	Q-2	QE-2	EQ-2	EQE-2	SQ-2	SQE-2	2	1/2					
	Q-3	QE-3	EQ-3	EQE-3	SQ-3	SQE-3	3	1					
	Q-4	QE-4	EQ-4	EQE-4	SQ-4	SQE-4	4	1-1/2					
	Q-5	QE-5	EQ-5	EQE-5	SQ-5	SQE-5	5	2					
	Q-6	QE-6	EQ-6	EQE-6	SQ-6	SQE-6	6	3					
507 (P) 402A (L)	Q-0	QE-0	EQ-0	EQE-0	SQ-0	SQE-0	0	1/6					
	Q-1	QE-1	EQ-1	EQE-1	SQ-1	SQE-1	1	1/4					
	Q-2	QE-2	EQ-2	EQE-2	SQ-2	SQE-2	2	1/2					
	Q-3	QE-3	EQ-3	EQE-3	SQ-3	SQE-3	3	1					
	Q-4	QE-4	EQ-4	EQE-4	SQ-4	SQE-4	4	1-1/2					
	Q-5	QE-5	EQ-5	EQE-5	SQ-5	SQE-5	5	2					
	Q-6	QE-6	EQ-6	EQE-6	SQ-6	SQE-6	6	3					

BQ Specifications – Element Size No. 43 (R-22) And NO. 45 (R-410a), Knife Edge Joint

REFRIGERANT (Sporlan Code)	BODY TYPE - CARTRIDGE						CARTRIDGE	NOMINAL CAPACITY Tons of Refrigeration	THERMOSTATIC CHARGES AVAILABLE	STANDARD TUBING LENGTH Feet	CONNECTIONS Inches Blue figures are standard and will be furnished unless otherwise specified.	NET WEIGHT - lbs.	SHIPPING WEIGHT - lbs.
	SAE Flare		Extended ODF Solder										
	Internal Equalizer ①	External Equalizer ②	Internal Equalizer ①	External Equalizer ②	Internal Equalizer ①	External Equalizer ②							
22 (V) 407C (N) 407A (V) 422D (V)	BQ-AAA	BQE-AAA	EBQ-AAA	EBQE-AAA	SBQ-AAA	SBQE-AAA	AAA	1/8 thru 1/3	Refer to Recommended Thermostatic Elements on Page 17	5	BQ & BQE 1/4 x 3/8 SAE 90° Angle Inlet or 1/4 x 1/2 SAE 90° Angle Inlet or 3/8 x 1/2 SAE 90° Angle Inlet  EBQ Only 3/8 x 1/2 ODF Straight Thru  EBQE Only 3/8 x 1/2 ODF Straight Thru or 3/8 x 1/2 ODF 90° Angle Inlet or 1/2 x 5/8 ODF Straight Thru or 1/2 x 7/8 ODF Straight Thru  SBQ & SBQE Only 3/8 x 1/2 ODF 90° Angle Inlet	1	1-1/2
	BQ-AA	BQE-AA	EBQ-AA	EBQE-AA	SBQ-AA	SBQE-AA	AA	1/2 thru 2/3					
	BQ-A	BQE-A	EBQ-A	EBQE-A	SBQ-A	SBQE-A	A	3/4 thru 1-1/2					
	BQ-B	BQE-B	EBQ-B	EBQE-B	SBQ-B	SBQE-B	B	1-3/4 thru 3					
	BQ-C	BQE-C	EBQ-C	EBQE-C	SBQ-C	SBQE-C	C	3-1/4 thru 5-1/2					
134a (J) 12 (F) 401A (X) 409A (F)	BQ-AAA	BQE-AAA	EBQ-AAA	EBQE-AAA	SBQ-AAA	SBQE-AAA	AAA	1/8 thru 1/5					
	BQ-AA	BQE-AA	EBQ-AA	EBQE-AA	SBQ-AA	SBQE-AA	AA	1/4 thru 1/3					
	BQ-A	BQE-A	EBQ-A	EBQE-A	SBQ-A	SBQE-A	A	1/2 thru 1					
	BQ-B	BQE-B	EBQ-B	EBQE-B	SBQ-B	SBQE-B	B	1-1/4 thru 1-3/4					
	BQ-C	BQE-C	EBQ-C	EBQE-C	SBQ-C	SBQE-C	C	2 thru 3					
404A (S) 502 (R) 408A (R)	BQ-AAA	BQE-AAA	EBQ-AAA	EBQE-AAA	SBQ-AAA	SBQE-AAA	AAA	1/8 thru 1/5					
	BQ-AA	BQE-AA	EBQ-AA	EBQE-AA	SBQ-AA	SBQE-AA	AA	1/4 thru 1/3					
	BQ-A	BQE-A	EBQ-A	EBQE-A	SBQ-A	SBQE-A	A	1/2 thru 1					
	BQ-B	BQE-B	EBQ-B	EBQE-B	SBQ-B	SBQE-B	B	1-1/4 thru 2					
	BQ-C	BQE-C	EBQ-C	EBQE-C	SBQ-C	SBQE-C	C	2-1/4 thru 3					
410A (Z)	–	–	EBQ-AAA	EBQE-AAA	SBQ-AAA	SBQE-AAA	AAA	1/4 thru 1/3					
	–	–	EBQ-AA	EBQE-AA	SBQ-AA	SBQE-AA	AA	1/2 thru 3/4					
	–	–	EBQ-A	EBQE-A	SBQ-A	SBQE-A	A	1 thru 1-3/4					
	–	–	EBQ-B	EBQE-B	SBQ-B	SBQE-B	B	2 thru 3-1/2					
	–	–	EBQ-C	EBQE-C	SBQ-C	SBQE-C	C	4 thru 6					
507 (P) 402A (L)	BQ-AAA	BQE-AAA	EBQ-AAA	EBQE-AAA	SBQ-AAA	SBQE-AAA	AAA	1/8 thru 1/5					
	BQ-AA	BQE-AA	EBQ-AA	EBQE-AA	SBQ-AA	SBQE-AA	AA	1/4 thru 1/3					
	BQ-A	BQE-A	EBQ-A	EBQE-A	SBQ-A	SBQE-A	A	1/2 thru 1					
	BQ-B	BQE-B	EBQ-B	EBQE-B	SBQ-B	SBQE-B	B	1-1/4 thru 2					
	BQ-C	BQE-C	EBQ-C	EBQE-C	SBQ-C	SBQE-C	C	2-1/4 thru 3					

① Valves listed in the column are NOT AVAILABLE with MOP type air conditioning charges.  
 ② Standard External Equalizer 1/4" SAE (Q and BQ Body), 1/4" ODF (SQ, SBQ, EQ and EBQ Body).  
 ③ The 3/8" SAE inlet fitting has a long taper on the flare surface. A 3/8" x 1/4" reducing flare nut will allow 1/4" OD tubing to be attached to this fitting.  
 ④ ODF Solder indicates a female connection on the valve of proper diameter to receive copper tubing of corresponding OD size. Thus 1/2" ODF will receive 1/2" OD tubing.

# ▼ TYPE Q & BQ

For Refrigerants 22, 134a, 404A, 410A\*, 507  
SAE Flare & Extended ODF Solder Connections

\* Type Q, EQ, SQ, and BQ are not approved for R-410A applications.

TYPE QE	TYPE BQE
---------	----------

1/4 SAE Inlet Strainer P/N 3008-000  
3/8 SAE Inlet Strainer P/N 1538-000

### QE & BQE Dimensions

CONNECTIONS - Inches

FITTING SIZE	A	B	C
1/4 SAE, 90° Angle	1.19	—	1.44
3/8 SAE, 90° Angle	1.35	—	1.08
3/8 SAE	—	1.61	—
1/2 SAE	—	1.80	—

Top View

1/4 SAE Inlet Strainer P/N 3008-000  
3/8 SAE Inlet Strainer P/N 1538-000

TYPE EQE	TYPE EBQE
----------	-----------

3/8 ODF Insert Strainer P/N 877-003  
1/2 ODF Insert Strainer P/N 877-004

### EQE & EBQE Dimensions

CONNECTIONS - Inches

FITTING SIZE	A	B	C
3/8	2.50	—	0.31
1/2	2.42	2.48	0.40
5/8	—	2.48	0.50
7/8	—	2.39	0.78

Top View

3/8 ODF Insert Strainer P/N 877-003  
1/2 ODF Insert Strainer P/N 877-004

TYPE SQE	TYPE SBQE
----------	-----------

Removable Strainer P/N 3427-000

Top View

Removable Strainer P/N 3427-000

### Bulb Sizes - Inches

STANDARD CHARGES	REFRIGERANT				
	22	134a	404A	410A	507
C	0.50 OD x 3.00				
Z & ZP Series	0.50 OD x 3.00	—	0.50 OD x 3.00	—	0.50 OD x 3.00
CP Series	0.50 OD x 3.00				
GA	0.75 OD x 2.00	—	—	0.75 OD x 2.00	—

# ▼ TYPE G

For Refrigerants 22, 134a, 404A, 507  
SAE Flare Connections

Sporlan Type G valve is a forged brass body, externally adjustable valve with SAE flare connections. The thermostatic element is replaceable, and the inlet connection has a removable 100 mesh strainer. This valve is designed for small refrigeration systems such as refrigerated cases, coolers and freezers. In addition to refrigeration applications, the externally equalized Type G valve may be used for small capacity air conditioning and heat pump units.

**Outlet Connections**  
1/2" SAE

**Mating Distributors (See Bulletin 20-10)**  
1603, 1605, 1606, 1608, 1650(R)

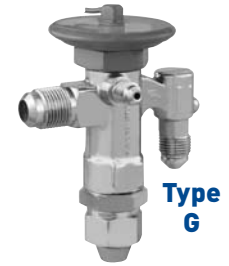

## Specifications – Element Size No. 53, Knife Edge Joint

REFRIGERANT (Sporlan Code)	VALVE TYPE		NOMINAL CAPACITY Tons of Refrigeration	THERMOSTATIC CHARGES AVAILABLE	STANDARD TUBING LENGTH Feet	CONNECTIONS - Inches SAE Flare <i>Blue figures are standard and will be furnished unless otherwise specified.</i>		NET WEIGHT - lbs.	SHIPPING WEIGHT - lbs.															
	Internal Equalizer ①	External Equalizer 1/4" SAE Flare				INLET	OUTLET																	
<b>22 (V)</b> 407C (N) 407A (V) 422D (V)	GV-1/5	GVE-1/5	1/5	Refer to Recommended Thermostatic Charges on page 3	5	1/4 or 3/8 ②	1/2	2	3															
	GV-1/3	GVE-1/3	1/3			1/4 or 3/8 ②																		
	GV-1/2	GVE-1/2	1/2			3/8 ②																		
	GV-3/4	GVE-3/4	3/4																					
	GV-1	GVE-1	1																					
	GV-1-1/2	GVE-1-1/2	1-1/2																					
	–	GVE-2	2																					
GV-2-1/2	–	2-1/2																						
–	GVE-3	3																						
<b>134a (J)</b> 12 (F) 401A (X) 409A (F)	GJ-1/8	GJE-1/8	1/8			Refer to Recommended Thermostatic Charges on page 3				5	1/4 or 3/8 ②	1/2	2	3										
	GJ-1/6	GJE-1/6	1/6								1/4 or 3/8 ②													
	GJ-1/4	GJE-1/4	1/4								1/4 or 3/8 ②													
	GJ-1/2	GJE-1/2	1/2																					
	GJ-1	GJE-1	1																					
	GJ-1-1/2	GJE-1-1/2	1-1/2																					
–	GJE-2	2																						
<b>404A (S)</b> 502 (R) 408A (R)	GS-1/8	GSE-1/8	1/8								Refer to Recommended Thermostatic Charges on page 3				5	1/4 or 3/8 ②	1/2	2	3					
	GS-1/6	GSE-1/6	1/6													1/4 or 3/8 ②								
	GS-1/4	GSE-1/4	1/4													1/4 or 3/8 ②								
	GS-1/2	GSE-1/2	1/2																					
	GS-1	GSE-1	1																					
	GS-1-1/2	GSE-1-1/2	1-1/2																					
–	GSE-2	2																						
<b>507 (P)</b> 402A (L)	GP-1/8	GPE-1/8	1/8													Refer to Recommended Thermostatic Charges on page 3				5	1/4 or 3/8 ②	1/2	2	3
	GP-1/6	GPE-1/6	1/6																		1/4 or 3/8 ②			
	GP-1/4	GPE-1/4	1/4																		1/4 or 3/8 ②			
	GP-1/2	GPE-1/2	1/2																					
	GP-1	GPE-1	1																					
	GP-1-1/2	GPE-1-1/2	1-1/2																					
–	GPE-2	2																						

① Valves listed in this column NOT AVAILABLE with MOP Type air conditioning charges.  
② The 3/8" SAE inlet fitting has a long taper on the flare surface. A 3/8" x 1/4" reducing flare nut will allow 1/4" OD tubing to be attached to this fitting.

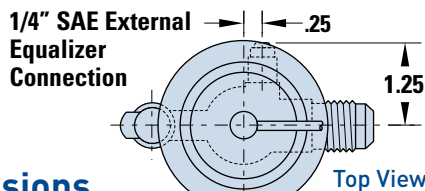

## Dimensions BULB SIZES- Inches

STANDARD CHARGES	REFRIGERANT			
	22	134a	404A	507
C	0.50 OD x 3.50			
Z & ZP Series	0.50 OD x 3.50	–	0.50 OD x 3.50	–
X	0.75 OD x 4.00	–	0.75 OD x 4.00	–
CP Series	0.50 OD x 3.50			
VGA	0.75 OD x 2.00	–	–	–

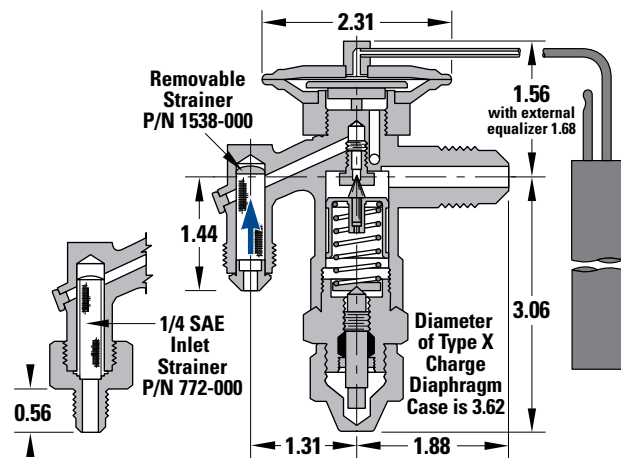

# ▼ TYPE EG

For Refrigerants 22, 134a, 404A, 507  
ODF Solder Connections

Sporlan Type EG valve is a forged brass body, externally adjustable valve with ODF solder connections. The thermostatic element is replaceable, and the inlet connection has a removable 100 mesh strainer which can be cleaned and/or replaced without removing the valve from the line. This valve is designed for small refrigeration systems such as refrigerated cases, coolers and freezers. In addition to refrigeration applications, the externally equalized Type EG valve

may be used for small capacity air conditioning and heat pump units.

**Outlet Connections**  
1/2" ODF

**Mating Distributors (See Bulletin 20-10)**  
D260, D262



Replaceable Strainer  
U.S. Patent No. 5,232,015

## Specifications – Element Size No. 53, Knife Edge Joint

REFRIGERANT (Sporlan Code)	VALVE TYPE		NOMINAL CAPACITY Tons of Refrigeration	THERMOSTATIC CHARGES AVAILABLE	STANDARD TUBING LENGTH Feet	CONNECTIONS - Inches ② ODF Solder Blue figures are standard and will be furnished unless otherwise specified.		NET WEIGHT - lbs.	SHIPPING WEIGHT - lbs.
	Internal Equalizer ①	External Equalizer 1/4" ODF Solder				INLET	OUTLET		
<b>22 (V)</b> 407C (N) 407A (V) 422D (V)	EGV-1/5	EGVE-1/5	1/5	Refer to Recommended Thermostatic Charges on page 3	5	3/8	1/2	2	3
	EGV-1/3	EGVE-1/3	1/3						
	EGV-1/2	EGVE-1/2	1/2						
	EGV-3/4	EGVE-3/4	3/4						
	EGV-1	EGVE-1	1						
	EGV-1-1/2	EGVE-1-1/2	1-1/2						
	—	EGVE-2	2						
EGV-2-1/2	—	2-1/2							
—	EGVE-3	3							
<b>134a (J)</b> 12 (F) 401A (X) 409A (F)	EGJ-1/8	EGJE-1/8	1/8						
	EGJ-1/6	EGJE-1/6	1/6						
	EGJ-1/4	EGJE-1/4	1/4						
	EGJ-1/2	EGJE-1/2	1/2						
	EGJ-1	EGJE-1	1						
	EGJ-1-1/2	EGJE-1-1/2	1-1/2						
—	EGJE-2	2							
<b>404A (S)</b> 502 (R) 408A (R)	EGS-1/8	EGSE-1/8	1/8						
	EGS-1/6	EGSE-1/6	1/6						
	EGS-1/4	EGSE-1/4	1/4						
	EGS-1/2	EGSE-1/2	1/2						
	EGS-1	EGSE-1	1						
	EGS-1-1/2	EGSE-1-1/2	1-1/2						
—	EGSE-2	2							
<b>507 (P)</b> 402A (L)	EGP-1/8	EGPE-1/8	1/8						
	EGP-1/6	EGPE-1/6	1/6						
	EGP-1/4	EGPE-1/4	1/4						
	EGP-1/2	EGPE-1/2	1/2						
	EGP-1	EGPE-1	1						
	EGP-1-1/2	EGPE-1-1/2	1-1/2						
—	EGPE-2	2							

① Valves listed in this column NOT AVAILABLE with MOP Type air conditioning charges.  
② ODF Solder indicates a female connection on the valve of proper diameter to receive copper tubing of corresponding OD size. Thus 1/2" ODF will receive 1/2" OD tubing.

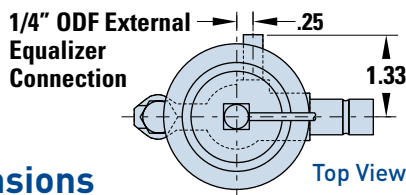

## Dimensions BULB SIZES- Inches

STANDARD CHARGES	REFRIGERANT			
	22	134a	404A	507
C	0.50 OD x 3.50			
Z & ZP Series	0.50 OD x 3.50	—	0.50 OD x 3.50	—
X	0.75 OD x 4.00	—	0.75 OD x 4.00	—
CP Series	0.50 OD x 3.50		—	—
VGA	0.75 OD x 2.00	—	—	—

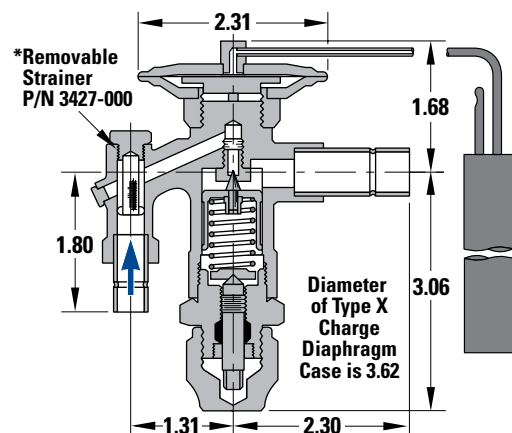

\* Type EG valves manufactured prior to June 1994 use a smaller inlet strainer, P/N 1935-000, which has a 1/2" brass hex head. Current Type EG valves use inlet strainer P/N 3427-000 which has a 5/8" brass hex head. These strainers are not interchangeable. The 3427-000 is available as a replacement part. The 1935-000 is no longer available.

# ▼ TYPE BF

For Refrigerants 22, 134a, 404A, 507  
SAE Flare Connections

Sporlan Type BF valve is a small brass bar body valve with SAE flare connections and balanced port construction. This valve has the same exterior dimensions as the Type F valve. The thermostatic element is replaceable, and the inlet connection has a removable 100 mesh strainer. The balanced port construction makes this valve ideally suited for small capacity refrigeration applications which operate over widely varying operating conditions.

**Outlet Connections**  
1/2" SAE

**Mating Distributors (See Bulletin 20-10)**  
1603, 1605, 1606, 1608, 1650(R)

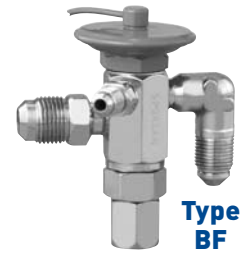

Type BF

## Specifications – Element Size No. 43, Knife Edge Joint

REFRIGERANT (Sporlan Code)	VALVE TYPE		PORT SIZE	NOMINAL CAPACITY Tons of Refrigeration	THERMOSTATIC CHARGES AVAILABLE	STANDARD TUBING LENGTH Feet	CONNECTIONS - Inches SAE Flare Blue figures are standard and will be furnished unless otherwise specified.			NET WEIGHT - lbs.	SHIPPING WEIGHT - lbs.
	SAE Flare						INLET	OUTLET	EXTERNAL EQUALIZER		
	Internal Equalizer	External Equalizer									
<b>22 (V)</b> 407C (N) 407A (V) 422D (V)	BFV-AAA	BFVE-AAA	AAA	1/8 thru 1/3	C Z ZP40	30	1/4 or 3/8 Elbow ①	3/8 or 1/2	1/4	1	1-1/2
	BFV-AA	BFVE-AA	AA	1/2 thru 2/3			1/4 or 3/8 Elbow ①				
	BFV-A	BFVE-A	A	3/4 thru 1-1/2			3/8 Elbow				
	BFV-B	BFVE-B	B	1-3/4 thru 3							
	BFV-C	BFVE-C	C	3-1/4 thru 5-1/2							
<b>134a (J)</b> 12 (F) 401A (X) 409A (F)	BFJ-AAA	BFJE-AAA	AAA	1/8 thru 1/5	C	30	1/4 or 3/8 Elbow ①	3/8 or 1/2	1/4	1	1-1/2
	BFJ-AA	BFJE-AA	AA	1/4 thru 1/3			1/4 or 3/8 Elbow ①				
	BFJ-A	BFJE-A	A	1/2 thru 1			3/8 Elbow				
	BFJ-B	BFJE-B	B	1-1/4 thru 1-3/4							
<b>404A (S)</b> 502 (R) 408A (R)	BFS-AAA	BFSE-AAA	AAA	1/8 thru 1/5	C Z ZP	30	1/4 or 3/8 Elbow ①	3/8 or 1/2	1/4	1	1-1/2
	BFS-AA	BFSE-AA	AA	1/4 thru 1/3			1/4 or 3/8 Elbow ①				
	BFS-A	BFSE-A	A	1/2 thru 1			3/8 Elbow				
	BFS-B	BFSE-B	B	1-1/4 thru 2							
<b>507 (P)</b> 402A (L)	BFP-AAA	BFPE-AAA	AAA	1/8 thru 1/5	C Z ZP	30	1/4 or 3/8 Elbow ①	3/8 or 1/2	1/4	1	1-1/2
	BFP-AA	BFPE-AA	AA	1/4 thru 1/3			1/4 or 3/8 Elbow ①				
	BFP-A	BFPE-A	A	1/2 thru 1			3/8 Elbow				
	BFP-B	BFPE-B	B	1-1/4 thru 2							
	BFP-C	BFPE-C	C	2-1/4 thru 3							

① The 3/8" SAE inlet fitting has a long taper on the flare surface. A 3/8" x 1/4" reducing flare nut will allow 1/4" OD tubing to be attached to this fitting.

## Dimensions

### CONNECTIONS - Inches

FITTING SIZE SAE Flare	A	B	C
1/4 Elbow	1.19	—	1.34
3/8 Elbow	1.35	—	0.98
3/8 SAE	—	1.61	—
1/2 SAE	—	1.80	—

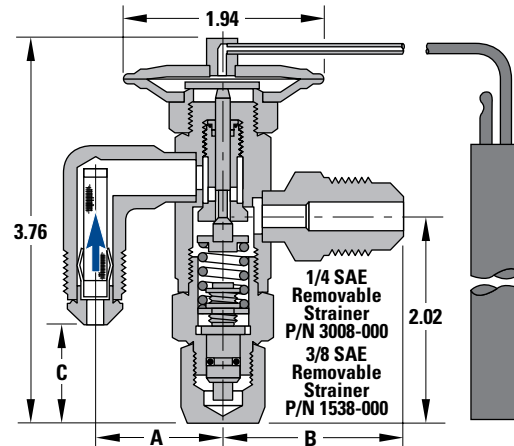
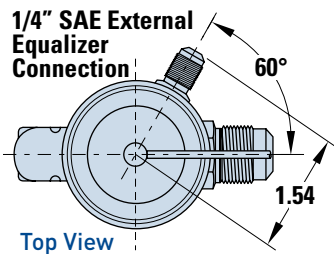

## Bulb Sizes - Inches

STANDARD CHARGES	REFRIGERANT			
	22	134a	404A	507
C	0.50 OD x 3.00			
Z & ZP Series	0.50 OD x 3.00	—	0.50 OD x 3.00	

# ▼ TYPE SBF & EBF

For Refrigerants 22, 134a, 404A, 507  
Extended Solder Connections

Sporlan Types SBF & EBF are small brass bar body valves with Extended ODF solder connections and the same balanced port construction as the Type BF valve. Both valves have replaceable thermostatic elements. The Type EBF has a 100 mesh insert strainer. The Type SBF has a 100 mesh removable strainer that can be cleaned and/or replaced while the valve is still soldered to the system tubing. The balanced port construction makes these valves ideally suited for small

capacity refrigeration applications which operate over widely varying conditions.

**Outlet Connections**  
1/2" ODF, 5/8" ODF

**Mating Distributors (See Bulletin 20-10)**  
D260, D262, 1620, 1622, 1651(R)

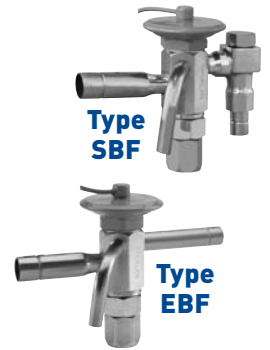

Replaceable Strainer  
U.S. Patent No. 5,232,015

## Specifications – Element Size No. 43, Knife Edge Joint

REFRIGERANT (Sporlan Code)	TYPE SBF		TYPE EBF		PORT SIZE	NOMINAL CAPACITY RANGE Tons of Refrigeration	THERMOSTATIC CHARGES AVAILABLE	STANDARD TUBING LENGTH Inches	CONNECTIONS - Inches			NET WEIGHT - lbs.	SHIPPING WEIGHT - lbs.
	Extended ODF Solder with replaceable strainer		Extended ODF Solder						① Extended ODF Solder Blue figures are standard and will be furnished unless otherwise specified.				
	Internal Equalizer	External Equalizer	Internal Equalizer	External Equalizer					INLET	OUTLET	EXTERNAL EQUALIZER		
<b>22 (V)</b> 407C (N) 407A (V) 422D (V)	SBFV-AAA	SBFVE-AAA	EBFV-AAA	EBFVE-AAA	AAA	1/8 thru 1/3	C Z ZP40	30	3/8	1/2 or 5/8	1/4 Pointed Toward Bottom Cap or Parallel to Outlet Connection	1	1-1/2
	SBFV-AA	SBFVE-AA	EBFV-AA	EBFVE-AA	AA	1/2 thru 2/3							
	SBFV-A	SBFVE-A	EBFV-A	EBFVE-A	A	3/4 thru 1-1/2							
	SBFV-B	SBFVE-B	EBFV-B	EBFVE-B	B	1-3/4 thru 3							
	SBFV-C	SBFVE-C	EBFV-C	EBFVE-C	C	3-1/4 thru 5-1/2							
<b>134a (J)</b> 12 (F) 401A (X) 409A (F)	SBFJ-AAA	SBFJE-AAA	EBFJ-AAA	EBFJE-AAA	AAA	1/8 thru 1/5	C	30	3/8	1/2 or 5/8	1/4 Pointed Toward Bottom Cap or Parallel to Outlet Connection	1	1-1/2
	SBFJ-AA	SBFJE-AA	EBFJ-AA	EBFJE-AA	AA	1/4 thru 1/3							
	SBFJ-A	SBFJE-A	EBFJ-A	EBFJE-A	A	1/2 thru 1							
	SBFJ-B	SBFJE-B	EBFJ-B	EBFJE-B	B	1-1/4 thru 1-3/4							
	SBFJ-C	SBFJE-C	EBFJ-C	EBFJE-C	C	2 thru 3							
<b>404A (S)</b> 502 (R) 408A (R)	SBFS-AAA	SBFSE-AAA	EBFS-AAA	EBFSE-AAA	AAA	1/8 thru 1/5	C Z ZP	30	3/8	1/2 or 5/8	1/4 Pointed Toward Bottom Cap or Parallel to Outlet Connection	1	1-1/2
	SBFS-AA	SBFSE-AA	EBFS-AA	EBFSE-AA	AA	1/4 thru 1/3							
	SBFS-A	SBFSE-A	EBFS-A	EBFSE-A	A	1/2 thru 1							
	SBFS-B	SBFSE-B	EBFS-B	EBFSE-B	B	1-1/4 thru 2							
	SBFS-C	SBFSE-C	EBFS-C	EBFSE-C	C	2-1/4 thru 3							
<b>507 (P)</b> 402A (L)	SBFP-AAA	SBFPE-AAA	EBFP-AAA	EBFPE-AAA	AAA	1/8 thru 1/5	C Z ZP	30	3/8	1/2 or 5/8	1/4 Pointed Toward Bottom Cap or Parallel to Outlet Connection	1	1-1/2
	SBFP-AA	SBFPE-AA	EBFP-AA	EBFPE-AA	AA	1/4 thru 1/3							
	SBFP-A	SBFPE-A	EBFP-A	EBFPE-A	A	1/2 thru 1							
	SBFP-B	SBFPE-B	EBFP-B	EBFPE-B	B	1-1/4 thru 2							
	SBFP-C	SBFPE-C	EBFP-C	EBFPE-C	C	2-1/4 thru 3							

① ODF Solder indicates a female connection on the valve of proper diameter to receive copper tubing of corresponding OD size. Thus 1/2" ODF will receive 1/2" OD tubing.

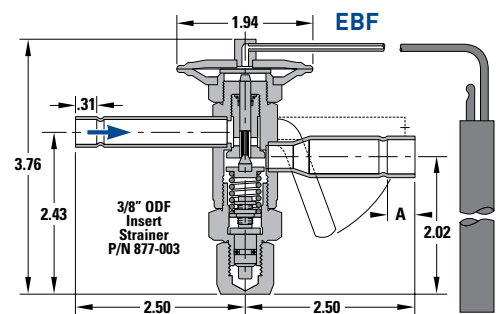
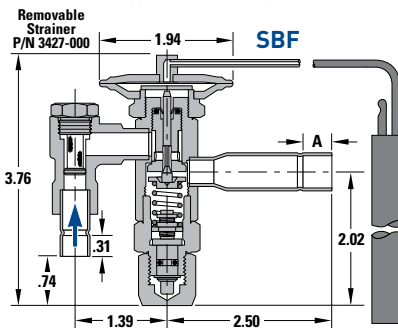
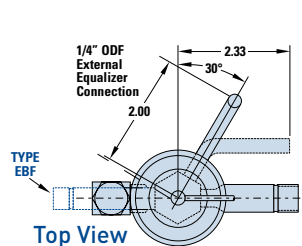

## Dimensions

CONNECTIONS - Inches

OUTLET FITTING SIZE	A
1/2	0.40
5/8	0.50

Bulb Sizes - Inches

STANDARD CHARGES	REFRIGERANT			
	22	134a	404A	507
C	0.50 OD x 3.00			
Z & ZP Series	0.50 OD x 3.00	-	0.50 OD x 3.00	

# ▼ TYPE S

For Refrigerants 22, 134a, 404A, 507  
ODF Solder Connections

Sporlan Type S valve is a brass bar body, externally adjustable valve with ODF solder connections. The thermostatic element is replaceable, and the inlet connection has a permanent 12 mesh strainer. This valve is designed for both air conditioning and refrigeration applications.

**Outlet Connections**  
5/8" ODF, 7/8" ODF, 1-1/8" ODF

**Mating Distributors (See Bulletin 20-10)**  
1112, 1113, 1115, 1116, 1620, 1622, 1651(R), 1653(R), 1655(R)

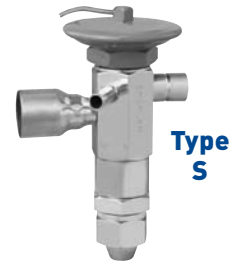

Type S

## Specifications – Element Size No. 83, Knife Edge Joint

REFRIGERANT (Sporlan Code)	VALVE TYPE		NOMINAL CAPACITY Tons of Refrigeration	THERMOSTATIC CHARGES AVAILABLE	STANDARD TUBING LENGTH Feet	CONNECTIONS - Inches ② ODF Solder Blue figures are standard and will be furnished unless otherwise specified.		NET WEIGHT - lbs.	SHIPPING WEIGHT - lbs.
	Internal Equalizer ①	External Equalizer				INLET	OUTLET		
<b>22 (V)</b> 407C (N) 407A (V) 422D (V)	SV-2	SVE-2	2	Refer to Recommended Thermostatic Charges on page 3	5	3/8 or 1/2	5/8, 7/8 or 1-1/8	2	3
	SV-3	SVE-3	3			1/2	5/8, 7/8 or 1-1/8		
	SV-4	SVE-4	4			5/8	7/8 or 1-1/8		
	SV-5	SVE-5	5			3/8 or 1/2	5/8, 7/8 or 1-1/8		
	–	SVE-8	8			1/2	5/8, 7/8 or 1-1/8		
–	SVE-10	10	5/8			7/8 or 1-1/8			
<b>134a (J)</b> 12 (F) 401A (X) 409A (F)	SJ-2	SJE-2	2			3/8 or 1/2	5/8, 7/8 or 1-1/8		
	SJ-2-1/2	SJE-2-1/2	2-1/2			1/2	5/8, 7/8 or 1-1/8		
	SJ-3	SJE-3	3			5/8	7/8 or 1-1/8		
	–	SJE-5	5			3/8 or 1/2	5/8, 7/8 or 1-1/8		
<b>404A (S)</b> 502 (R) 408A (R)	–	SJE-6	6			1/2	5/8, 7/8 or 1-1/8		
	SS-2	SSE-2	2			5/8	7/8 or 1-1/8		
	SS-3	SSE-3	3			3/8 or 1/2	5/8, 7/8 or 1-1/8		
	SS-4	SSE-4	4			1/2	5/8, 7/8 or 1-1/8		
	–	SSE-6	6			5/8	7/8 or 1-1/8		
<b>507 (P)</b> 402A (L)	–	SSE-7	7	3/8 or 1/2	5/8, 7/8 or 1-1/8				
	SP-2	SPE-2	2	1/2	5/8, 7/8 or 1-1/8				
	SP-3	SPE-3	3	5/8	7/8 or 1-1/8				
	SP-4	SPE-4	4	3/8 or 1/2	5/8, 7/8 or 1-1/8				
	–	SPE-6	6	1/2	5/8, 7/8 or 1-1/8				
–	SPE-7	7	5/8	7/8 or 1-1/8					

① Valves listed in this column NOT AVAILABLE with MOP Type air conditioning charges.

② ODF Solder indicates a female connection on the valve of proper diameter to receive copper tubing of corresponding OD size. Thus 5/8" ODF will receive 5/8" OD tubing.

## Dimensions

### CONNECTIONS - Inches

FITTING SIZE	A	B	C
3/8	1.34	–	0.31
1/2	1.29	1.36	0.40
5/8	1.50	1.57	0.50
7/8	–	2.13	0.78
1-1/8	–	2.19	0.91

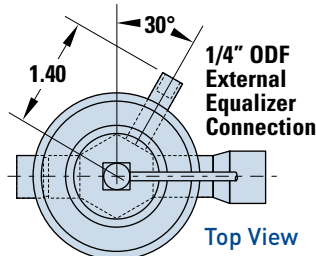

### Bulb Sizes - Inches

STANDARD CHARGES	REFRIGERANT			
	22	134a	404A	507
C	0.50 OD x 3.50			
Z & ZP Series	0.50 OD x 3.50	–	0.50 OD x 3.50	–
X	0.75 OD x 4.00	–	0.75 OD x 4.00	–
CP Series	0.50 OD x 3.50			
VGA	0.75 OD x 2.00	–	–	–

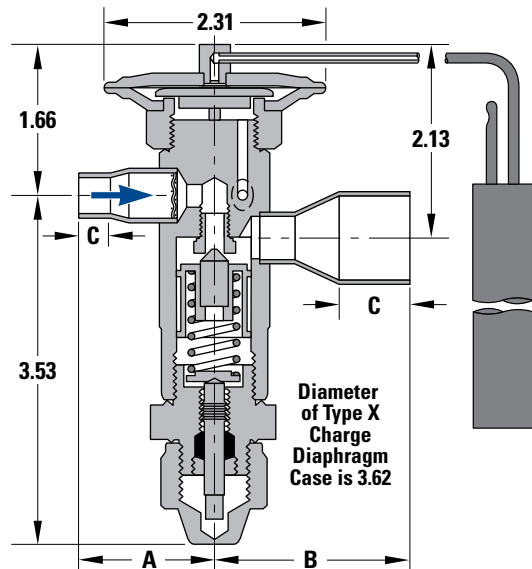

# ▼ TYPE EBS

For Refrigerants 22, 134a, 404A, 507  
Extended ODF Solder Connections

Sporlan Type EBS valve is a brass bar body valve having the same physical size as the Type S valve except the Type EBS features a balanced port construction and extended ODF connections. The thermostatic element is replaceable, and the inlet connection has a permanent 12 mesh strainer. The thermostatic element is replaceable. The balanced port construction makes this valve ideally suited for refrigeration and air conditioning applications which operate over widely varying conditions.

**Outlet Connections**  
7/8" ODF, 1-1/8" ODF, 1-3/8" ODF

**Mating Distributors (See Bulletin 20-10)**  
1112, 1113, 1115, 1116, 1117, 1126, 1128, 1653(R), 1655(R), 1657(R)

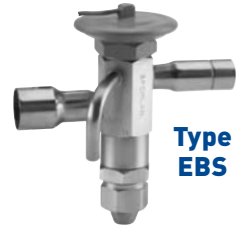

Type EBS

## Specifications – Element Size No. 83, Knife Edge Joint

REFRIGERANT (Sporlan Code)	VALVE TYPE	NOMINAL CAPACITY Tons of Refrigeration	THERMOSTATIC CHARGES AVAILABLE	STANDARD TUBING LENGTH Feet	CONNECTIONS - Inches ③			NET WEIGHT - lbs.	SHIPPING WEIGHT - lbs.
	External Equalizer				INLET	OUTLET	EXTERNAL EQUALIZER		
<b>22 (V)</b> 407C (N) 407A (V) 422D (V)	EBSVE-8 ②	8	* Refer to Recommended Thermostatic Charges on page 3	5	1/2 or <b>5/8</b>	<b>7/8</b> or 1-1/8	<b>1/4 Pointed Toward Bottom Cap</b> or Parallel to Outlet Connection	2	3
	EBSVE-11 ②	11			1/2, <b>5/8</b> or 7/8	<b>7/8</b> , 1-1/8 or 1-3/8			
	EBSVE-15	15			5/8 or <b>7/8</b>	<b>7/8</b> , <b>1-1/8</b> or 1-3/8			
	EBSVE-20	20			<b>7/8</b>	1-1/8 or <b>1-3/8</b>			
<b>134a (J)</b> 12 (F) 401A (X) 409A (F)	EBSJE-5 ②	5			1/2 or <b>5/8</b>	<b>7/8</b> or 1-1/8			
	EBSJE-7 ②	7			1/2, <b>5/8</b> or 7/8	<b>7/8</b> , 1-1/8 or 1-3/8			
	EBSJE-9	9			5/8 or <b>7/8</b>	<b>7/8</b> , <b>1-1/8</b> or 1-3/8			
	EBSJE-12	12			<b>7/8</b>	1-1/8 or <b>1-3/8</b>			
<b>404A (S)</b> 502 (R) 408A (R)	EBSSE-6 ②	6			1/2 or <b>5/8</b>	<b>7/8</b> or 1-1/8			
	EBSSE-7-1/2 ②	7-1/2			1/2, <b>5/8</b> or 7/8	<b>7/8</b> , 1-1/8 or 1-3/8			
	EBSSE-10	10			5/8 or <b>7/8</b>	<b>7/8</b> , <b>1-1/8</b> or 1-3/8			
	EBSSE-13	13			<b>7/8</b>	1-1/8 or <b>1-3/8</b>			
<b>507 (P)</b> 402A (L)	EBSPE-6 ②	6			1/2 or <b>5/8</b>	<b>7/8</b> or 1-1/8			
	EBSPE-7-1/2 ②	7-1/2			1/2, <b>5/8</b> or 7/8	<b>7/8</b> , 1-1/8 or 1-3/8			
	EBSPE-10	10			5/8 or <b>7/8</b>	<b>7/8</b> , <b>1-1/8</b> or 1-3/8			
	EBSPE-13	13			<b>7/8</b>	1-1/8 or <b>1-3/8</b>			

① ODF Solder indicates a female connection on the valve of proper diameter to receive copper tubing of corresponding OD size. Thus 5/8" ODF will receive 5/8" OD tubing.

② Approved for bi-directional applications.

③ Minimum quantities may apply to non-standard connections. Not all connection combinations are available.

\* X charge not available.

## Dimensions

### CONNECTIONS - Inches

FITTING SIZE	A	B	C
1/2	2.49	-	0.40
5/8	2.46	-	0.50
7/8	2.46	2.53	0.78
1-1/8	-	2.53	0.91
1-3/8	-	3.04	0.97

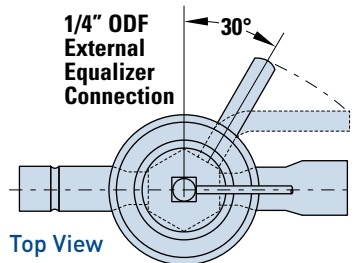

### Bulb Sizes - Inches

STANDARD CHARGES	REFRIGERANT			
	22	134a	404A	507
C	0.50 OD x 3.50			
Z & ZP Series	0.50 OD x 3.50	-	0.50 OD x 3.50	
CP Series	0.50 OD x 3.50			-
VGA	0.75 OD x 2.00	-	-	-

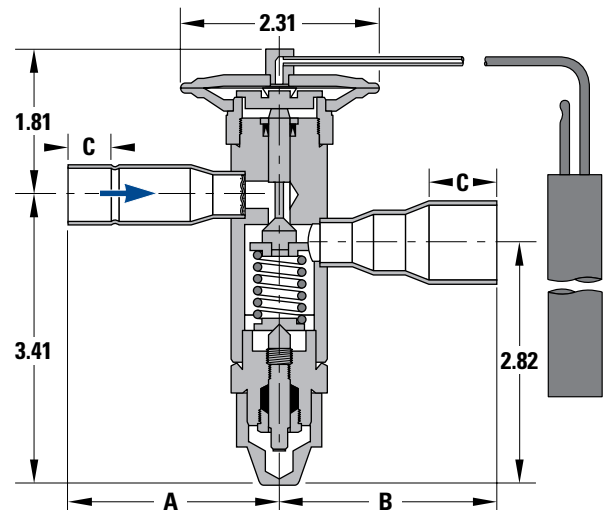

# ▼ TYPE O

For Refrigerants 22, 134a, 404A, 410A, 507  
ODF Solder Connections

Sporlan Type O valve is a brass bar body, externally adjustable valve with ODF solder connections. The thermostatic element is replaceable, and the inlet connection has a permanent 12 mesh strainer. This valve type features a balanced port construction, and it is designed for both air conditioning and refrigeration applications. A synthetic seating surface provides tight shut-off during system off periods.

35 tons R-410A, and a large body which extends capacities to 70 tons R-22 and 60 tons R-410A.

**Outlet Connections**

1-1/8" ODF, 1-3/8" ODF, 1-5/8" ODF

**Mating Distributors (See Bulletin 20-10)**

1115, 1116, 1117, 1125, 1126, 1127, 1128, 1143, 1655(R), 1657(R), 1659(R)

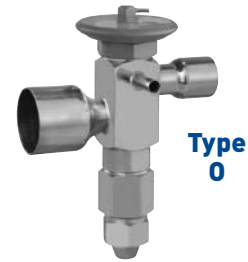

U.S. Patent  
No. 3,742,722

This valve type has two body styles: a small body which provides capacities up to 30 tons R-22 and

## Specifications – Element Size No. 83, No. 33, No. 85 (R-410a), And No. 85-3 (R-410a), Knife Edge Joint

REFRIGERANT (Sporlan Code)	VALVE TYPE	NOMINAL CAPACITY Tons of Refrigeration	THERMOSTATIC ELEMENT SIZE NO.	THERMOSTATIC CHARGES AVAILABLE	STANDARD TUBING LENGTH Feet	CONNECTIONS - Inches ① ODF Solder		NET WEIGHT - lbs.	SHIPPING WEIGHT - lbs.	
	External Equalizer					Blue figures are standard and will be furnished unless otherwise specified.				
						INLET	OUTLET			
<b>22 (V)</b> 407C (N) 407A (V) 422D (V)	OVE-15 ②	15	83	*Refer to Recommended Thermostatic Charges on page 3 <b>Note:</b> O Valve for R-410A available with ZGA only	5	7/8	1-1/8	2	3	
	OVE-20 ②	20					1-3/8			
	OVE-30 ②	30	33			1-1/8	1-3/8 or 1-5/8	4	5	
	OVE-40	40								
	OVE-55	55								
OVE-70	70									
<b>134a (J)</b> 12 (F) 401A (X) 409A (F)	OJE-9	9	83				7/8	1-1/8	2	3
	OJE-12	12				1-3/8				
	OJE-16	16	33			1-1/8	1-3/8 or 1-5/8	4	5	
	OJE-23	23								
	OJE-32	32								
OJE-40	40									
<b>404A (S)</b> 502 (R) 408A (R)	OSE-9	9	83		7/8	1-1/8	2	3		
	OSE-12	12		1-3/8						
	OSE-21	21	33	1-1/8	1-3/8 or 1-5/8	4	5			
	OSE-30	30								
	OSE-35	35								
OSE-45	45									
<b>410A (Z)</b>	OZE-20 ②	20	85		7/8	1-1/8	2	3		
	OZE-25 ②	25		1-3/8						
	OZE-35 ②	35	85-3	1-1/8	1-3/8	4	5			
	OZE-50	50								
OZE-60	60									
<b>507 (P)</b> 402A (L)	OPE-9	9	83		7/8	1-1/8	2	3		
	OPE-12	12		1-3/8						
	OPE-21	21	33	1-1/8	1-3/8 or 1-5/8	4	5			
	OPE-30	30								
	OPE-35	35								
OPE-45	45									

① ODF Solder indicates a female connection on the valve of proper diameter to receive copper tubing of corresponding OD size. Thus 5/8" ODF will receive 5/8" OD tubing.

② Optional bi-directional feature is available, please contact Sporlan Division of Parker for more information.

\* X charge not available.

# ▼ TYPE 0

For Refrigerants 22, 134a, 404A, 410A, 507  
ODF Solder Connections

**TYPE 0 with NUMBER 83 and 85 ELEMENT**

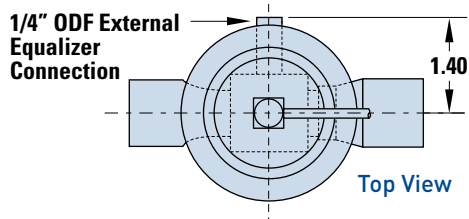

## Dimensions

### CONNECTIONS - Inches

STRAIGHT THRU ODF SOLDER	A	B	C
7/8	2.09	2.08	0.78
1-1/8	2.21	2.23	0.91
1-3/8	—	2.39	0.97

### Bulb Sizes - Inches

STANDARD CHARGES	REFRIGERANT				
	22	134a	404A	410A	507
C	0.50 OD X 3.50				
Z & ZP Series	0.50 OD X 3.50	—	0.50 OD X 3.50	—	0.50 OD X 3.50
CP Series	0.50 OD X 3.50				
GA	0.75 OD X 2.00	—	—	0.75 OD X 2.00	—

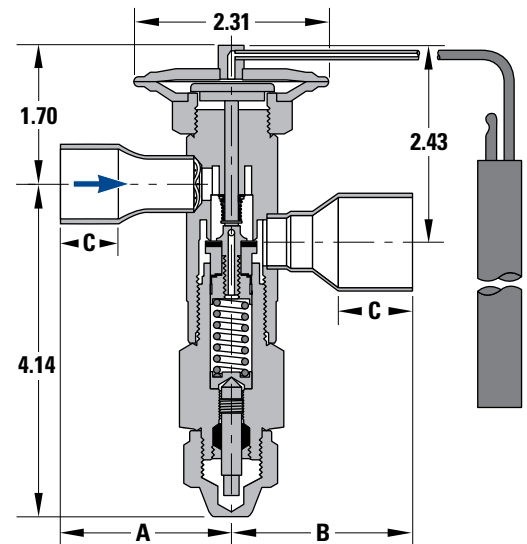

**TYPE 0 with NUMBER 33 and 85-3 ELEMENT**

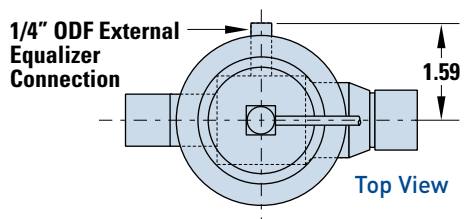

## Dimensions

### CONNECTIONS - Inches

STRAIGHT THRU ODF SOLDER	A	B	C
1-1/8	2.69	—	0.91
1-3/8	—	2.84	0.97
1-5/8	—	3.12	1.09

### Bulb Sizes - Inches

STANDARD CHARGES	REFRIGERANT				
	22	134a	404A	410A	507
C	0.75 OD x 4.00	0.50 OD x 5.00	0.75 OD x 4.00	—	0.75 OD x 4.00
Z & ZP Series	0.75 OD x 4.00	—	0.75 OD x 4.00	—	0.75 OD x 4.00
CP Series	0.75 OD x 4.00				
GA	0.75 OD x 4.00	—	—	0.75 OD X 2.00	—

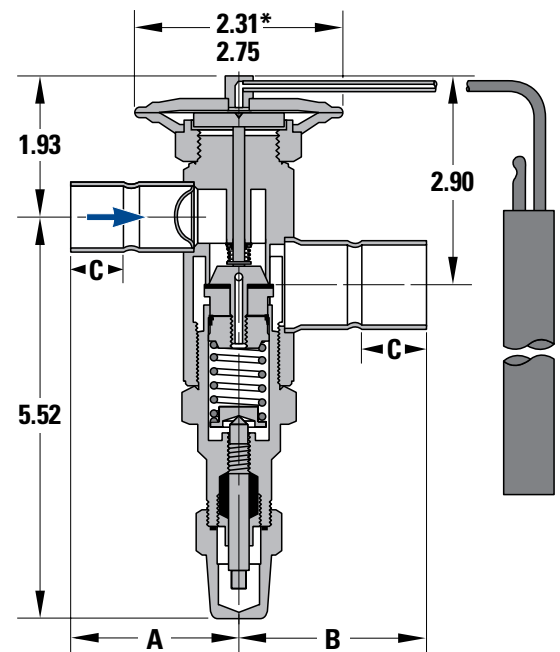

\*R-410A 85-3 Element.

## ▼ TYPE H and TYPE M

### Type H – Element Size No. 33, Knife Edge Joint, Standard Tubing Length 5 Feet Flange Ring Size – 1-1/4" OD x 1" ID.

REFRIGERANT (Sporlan Code)	VALVE TYPE			THERMOSTATIC CHARGES AVAILABLE	STANDARD TUBING LENGTH Feet	CONNECTIONS - Inches ③ ODF Solder Blue figures are standard and will be furnished unless otherwise specified.		FLANGE RING SIZE OD x ID Inches ④	NET WEIGHT - lbs.	SHIPPING WEIGHT - lbs.		
	Internal Equalizer ①	External Equalizer ②	NOMINAL CAPACITY Tons of Refrigeration			INLET	OUTLET					
<b>22 (V)</b> 407C (N) 407A (V) 422D (V)	HV-5-1/2	HVE-5-1/2	5-1/2	Refer to Recommended Thermostatic Charges on page 3	5	1.25 x 1.00	5	6				
	–	HVE-7	7								5/8 or 7/8	7/8 or 1-1/8
	–	HVE-11	11								7/8	7/8 or 1-1/8
	–	HVE-16	16									
–	HVE-20	20	5/8 or 7/8								7/8 or 1-1/8	
<b>134a (J)</b> 12 (F) 401A (X) 409A (F)	HJ-3	HJE-3										3
	HJ-4	HJE-4										4
	HJ-5	HJE-5										5
	–	HJE-8	8									
<b>404A (S)</b> 502 (R) 408A (R)	–	HJE-12	12								7/8	7/8 or 1-1/8
	HS-3	HSE-3	3									
	HS-4	HSE-4	4									
	–	HSE-6-1/2	6-1/2									
<b>507 (P)</b> 402A (L)	–	HSE-9	9								5/8 or 7/8	7/8 or 1-1/8
	–	HSE-12	12									
	HP-3	HPE-3	3									
	HP-4	HPE-4	4									
	–	HPE-6-1/2	6-1/2									
	–	HPE-9	9									
–	HPE-12	12	7/8	7/8 or 1-1/8								



H

See Bulletin 10-10  
for dimensional  
information.

- ① Valves listed in this column NOT AVAILABLE with MOP Type air conditioning charges.
- ② Standard External Equalizer Connection 1/4" SAE Flare, 1/4" ODF Solder connection available on request.
- ③ ODF Solder indicates a female connection on the valve of proper diameter to receive copper tubing of corresponding OD size. Thus, 5/8" ODF will receive 5/8" OD tubing.
- ④ Kit K-1178 with two brass bushings is available for two purposes: 1) To allow the current Type H valve to replace obsolete Types T and H with 1.125" x 0.75" flange rings by mating with the smaller flange ring bushings and/or distributors. 2) To allow the Type H to use 1/2" FPT connections — Part number 225-002 and 1/2" socket weld connections — Part number 580-000. Order the appropriate 1/2" connections and one K-1178 per valve.

### Type M – Element Size No. 63, Gasket Joint, Standard Tubing Length 5 Feet Flange Ring Size – 1-3/4" OD x 1-1/4" ID.

REFRIGERANT (Sporlan Code)	VALVE TYPE		THERMOSTATIC CHARGES AVAILABLE	Blue figures are standard and will be furnished unless otherwise specified.		FLANGE RING SIZE OD x ID Inches	NET WEIGHT - lbs.	SHIPPING WEIGHT - lbs.		
	External Equalizer ①	NOMINAL CAPACITY Tons of Refrigeration		STANDARD TUBING LENGTH Feet	② CONNECTIONS - Inches ③ ODF Solder Flange					
					INLET				OUTLET	
<b>22 (V)</b> 407C (N) 407A (V) 422D (V)	MVE-21	21	Refer to Recommended Thermostatic Charges on page 3	5 10	1.75 x 1.25	8	9			
	MVE-26	26							7/8 or 1-1/8	1-1/8 1-3/8 or 1-5/8
	MVE-34	34							7/8 or 1-1/8	
	MVE-42	42							7/8 or 1-1/8	
<b>134a (J)</b> 12 (F) 401A (X) 409A (F)	MJE-15	15							7/8 or 1-1/8	
	MJE-20	20							7/8 or 1-1/8	
	MJE-25	25								
	<b>404A (S)</b> 502 (R) 408A (R)	MSE-15							15	7/8 or 1-1/8
MSE-20		20								
MSE-25		25								
MSE-30		30								
<b>507 (P)</b> 402A (L)	MPE-15	15							7/8 or 1-1/8	
	MPE-20	20								
	MPE-25	25								
	MPE-30	30								



M

See Bulletin 10-10  
for dimensional  
information.

- ① Standard External Equalizer Connection 1/4" SAE Flare, 1/4" ODF Solder connection available on request.
- ② FPT connections also available on request; 1/2" FPT - Part Number 360-000, 3/4" FPT - Part Number 360-001, 1" FPT - Part Number 362-000.
- ③ ODF Solder indicates a female connection on the valve of proper diameter to receive copper tubing of corresponding OD size. Thus, 7/8" ODF will receive 7/8" OD tubing.

## ▼ TYPE V and TYPE W

**Type V** – Element Size No. 63, Gasket Joint, Standard Tubing Length 5 Feet  
Flange Ring Size – 1-3/4" OD x 1-1/2" ID.

REFRIGERANT (Sporlan Code)	VALVE TYPE		NOMINAL CAPACITY Tons of Refrigeration	THERMOSTATIC CHARGES AVAILABLE	Blue figures are standard and will be furnished unless otherwise specified.			FLANGE RING SIZE OD x ID Inches	NET WEIGHT - lbs.	SHIPPING WEIGHT - lbs.
	External Equalizer ①	ELEMENT SIZE NUMBER			STANDARD TUBING LENGTH Feet	② CONNECTIONS - Inches				
						③ ODF Solder Flange				
		INLET	OUTLET							
<b>22 (V)</b> 407C (N) 407A (V) 422D (V)	VVE-52	52	Refer to Recommended Thermostatic Charges on page 3	5 10	1-1/8 or 1-3/8	1-1/8 1-3/8 or 1-5/8	1.75 x 1.25	9	10	
	VVE-70	70								
	VVE-100	100								
<b>134a (J)</b> 12 (F) 401A (X) 409A (F)	VJE-35	35								
	VJE-45	45								
	VJE-55	55								
<b>404A (S)</b> 502 (R) 408A (R)	VSE-38	38								
	VSE-50	50								
	VSE-70	70								
<b>507 (P)</b> 402A (L)	VPE-38	38								
	VPE-50	50								
	VPE-70	70								



See Bulletin 10-10 for dimensional information.

① Standard External Equalizer Connection 1/4" SAE Flare, 1/4" ODF Solder connection available on request.  
② FPT connections also available on request; 1/2" FPT - Part Number 360-000, 3/4" FPT - Part Number 360-001, 1" FPT - Part Number 362-000.  
③ ODF Solder indicates a female connection on the valve of proper diameter to receive copper tubing of corresponding OD size. Thus, 7/8" ODF will receive 7/8" OD tubing.

**Type W** – Element Size No. 63, Small Capacity, No. 7 Large Capacity – Gasket Joint,  
Standard Tubing Length 10 Feet, Flange Ring Size – 2-3/4" OD x 2-3/16" ID.

REFRIGERANT (Sporlan Code)	VALVE TYPE		NOMINAL CAPACITY Tons of Refrigeration	THERMOSTATIC CHARGES AVAILABLE	ELEMENT SIZE NUMBER	Blue figures are standard and will be furnished unless otherwise specified.			FLANGE RING SIZE OD x ID Inches ④	NET WEIGHT - lbs.	SHIPPING WEIGHT - lbs.	
	External Equalizer ①	ELEMENT SIZE NUMBER				STANDARD TUBING LENGTH Feet	② CONNECTIONS - Inches					
							③ ODF Solder Flange					
		INLET	OUTLET									
<b>22 (V)</b> 407C (N) 407A (V) 422D (V)	WVE-135	135	10	③	63	1-1/8 1-3/8 1-5/8 or 2-1/8	1-1/8 1-3/8 1-5/8 or 2-1/8	2.75 x 2.19	10	11		
	WVE-180	180									G only	7
	<b>134a (J)</b> 12 (F) 401A (X) 409A (F)	WJE-80									80	
WJE-110		110									G only	7



See Bulletin 10-10 for dimensional information.

① Standard External Equalizer Connection 1/4" SAE Flare, 1/4" ODF Solder connection available on request.  
② ODF Solder indicates a female connection on the valve of proper diameter to receive copper tubing of corresponding OD size. Thus, 1-1/8" ODF will receive 1-1/8" OD tubing.  
③ Refer to Recommended Thermostatic Charges, page 3.  
④ For 1-1/2" NPT connections, order flanges separately for MA42 solenoid eg P/N 933-1. The customer must supply 5/8" diameter x 6" long bolts and 5/8" diameter nuts.

## ▼ LEVEL-MASTER® LIQUID LEVEL CONTROL

For complete information see your Sporlan Wholesaler, our website at [www.sporlan.com](http://www.sporlan.com), or write Sporlan and request Bulletin 60-15.

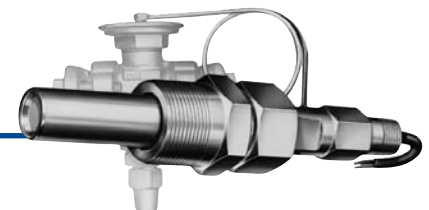

## REFRIGERANT DISTRIBUTORS & AUXILIARY SIDE CONNECTORS



1126



1651

Side Connection distributors for heat pump, hot gas defrost, and hot gas bypass systems.



ASC

(Auxiliary Side Connectors) for hot gas defrost, hot gas bypass and reverse cycle (heat pump) systems.

U.S. Patent No. 3,563,055

The Sporlan Distributor is an efficient refrigerant distributing device that assures uniform feeding of refrigerant to all passes of a multi-circuited evaporator. It can be used with any conventional externally equalized thermostatic expansion valve.

Auxiliary Side Connectors (ASC) permit the conversion of conventional Sporlan refrigerant distributors to hot gas bypass, hot gas defrost or reverse cycle service.

### Refrigerant Distributors

CONNECTION SIZE	TEV MODEL	DISTRIBUTOR TYPE	MAXIMUM NUMBER of CIRCUITS				NOZZLE TYPE	MATERIAL
			3/16	1/4	5/16	3/8		
1/2 SAE	BF, BQ, F, G, Q, RC, RI	1603	6	4	—	—	PERM.	#360 Brass
		1606	9	6	4	—	PERM.	
		1605	6	4	—	—	L	
		1608	9	6	4	—	L	
1/2 ODM	EBF, EBQ, EF, EQ, RC, RI, S, SBF, SBQ, SQ	D260	6	4	—	—	L	
		D262	9	7	4	—	L	
5/8 ODM	EBF, EQ, RC, RI, S, SBF	1620	6	4	—	—	J	
		1622	9	7	4	—	J	
7/8 ODM	EBQ, EBS, EQ, O, S	1112	7	6	4	2	G	
		1113	12	8	6	4	G	
1-1/8 ODM	EBS, O, S	1115	15	10	9	6	E	
		1116	20	15	—	—	E	
1-3/8 ODM	EBS, O, W	1117	18	15	9	7	C	
		1126	24	18	15	12	C	
		1128	28	25	21	16	C	
1-5/8 ODM	O, W	1125	28	24	20	16	A	
		1127	37	30	26	20	A	
		1143	40	36	30	24	A	
Type H Valve	H	1109	10	8	6	4	G	
		1124	30	23	18	15	E	
		1192	11	10	6	6	G	
Type M/V Valve	M, V	1121	34	24	20	16	C	
		1193	26	21	18	16	C	

### Side Connection Distributors

CONNECTION SIZE	TEV MODEL	DISTRIBUTOR TYPE	MAXIMUM NUMBER of CIRCUITS				NOZZLE TYPE	SIDE CONNECTION	MATERIAL
			3/16	1/4	5/16	3/8			
1/2 SAE	BF, BQ, F, G, Q, RC, RI	1650 (R)	7	5	—	—	PERM.	3/8 or 1/2 ODF	#360 Brass
5/8 ODM	EBF, EBQ, EQ, RC, RI, S, SBF, SBQ	1651 (R)	7	5	—	—	J (R)	3/8 or 1/2 ODF	
7/8 ODM	EBQ, EBS, EQ, O, S	1653 (R)	12	9	6	4	G (R)	1/2 or 5/8 ODF	
1-1/8 ODM	EBS, O, S	1655 (R)	20	12	10	7	E (R)	5/8 or 7/8 ODF	
1-3/8 ODM	EBS, O, W	1657 (R)	26	18	14	11	C (R)	7/8 or 1-1/8 ODF	
1-5/8 ODM	O, W	1659 (R)	32	24	18	14	A (R)	7/8 or 1-1/8 ODF	

### Auxiliary Side Connectors

TYPE	CONNECTION SIZES — Inches			NOZZLE SIZE	USED with DISTRIBUTOR TYPE
	INLET ODM SOLDER	OUTLET ODF SOLDER	AUXILIARY ODF SOLDER		
ASC-5-4	5/8	5/8	1/2	J	1620, 1622
ASC-7-4	7/8	7/8	1/2	G	1112, 1113
ASC-9-5	1-1/8	1-1/8	5/8	E	1115, 1116
ASC-11-7	1-3/8	1-3/8	7/8	C	1117, 1126, 1128
ASC-13-9	1-5/8	1-5/8	1-1/8	A	1125, 1127, 1143

### Nomenclature/Ordering Instructions

To order (1) type 1126 distributor with 16 – 1/4" circuits and number 15 nozzle use the following nomenclature:

One	1126	16	1/4	15
Quantity	Type	Number of Circuits	Circuit Size	Nozzle Orifice Number

For complete information on distributors and auxiliary side connections see your Sporlan Wholesaler, our website at [www.sporlan.com](http://www.sporlan.com), or write Sporlan and request Bulletin 20-10.

# ▼ SOLENOID VALVES

22, 134a, 401A, 402A, 404A, 407C, 502, 507

## 6 Proven Benefits of Sporlan Solenoid Valves

- Molded coil for all sizes.
- Class “F” temperature rating – Coil types MKC-1, OMKC-1, MKC-2 and OMKC-2.
- Extremely rugged, simple design – few parts.
- “E” Series may be brazed without disassembly.
- Tight closing through use of synthetic seating material.
- Can be used on Refrigerants 22, 134a, 401A, 402A, 404A, 407C, 502 and 507 because of high MOPD ratings.



A3P1



B25S2



OB10S2



E10S250

Sporlan Solenoid Valves are made in two general types, normally closed and normally open. The normally closed types may be further sub-divided into direct acting and pilot operated types.

The NORMALLY CLOSED A3 and E3 (Direct Acting) and E5 through the E42 series (Pilot Operated) and the NORMALLY OPEN OB9 and OE9 through the OE42 series may be mounted in either a horizontal or vertical line.

The Sporlan “E” series solenoid valves feature extended solder type connections as standard. One important benefit to the user is that all valves in the “E” series can be installed without disassembly using either low or no silver content brazing alloy. The “E” series is interchangeable with the “B” series, solder type valves, providing the

overall length can be accommodated.

All valves in the “E” series have the same capacities as the “A” & “B” series with the exception of the E42.

All Sporlan solenoid valves are designed for liquid, suction and discharge gas applications.

Most Sporlan Solenoid Valves are *Listed by Underwriters’ Laboratories, Inc. – Guide No. Y10Z – File No. MH4576 and Canadian Standards Association – Guide 440-A-O, Class 3221, File 19953 and CE provisions of the LVD 73/23/EEC and PED 97/23/EC.*

**See page 33 for R-410A Solenoid Valves.**

## Liquid Capacities – Tons

TYPE NUMBER		TONS OF REFRIGERATION**																			
“E” SERIES VALVES	“A” & “B” SERIES VALVES	22					134a					401A					402A				
		PRESSURE DROP – psi*																			
		1	2	3	4	5	1	2	3	4	5	1	2	3	4	5	1	2	3	4	5
E3	A3	0.9	1.3	1.6	1.9	2.1	0.8	1.2	1.5	1.8	2.0	0.9	1.3	1.6	1.9	2.1	0.6	0.9	1.1	1.2	1.4
E5	—	1.6	2.3	2.8	3.3	3.6	1.5	2.1	2.6	3.0	3.4	1.6	2.3	2.8	3.3	3.7	1.1	1.5	1.9	2.1	2.4
E6	B6	2.9	4.0	4.9	5.7	6.4	2.7	3.8	4.6	5.3	5.9	2.9	4.1	4.9	5.7	6.4	1.9	2.7	3.3	3.8	4.2
E9	B9	4.7	6.6	8.1	9.3	10.4	4.4	6.2	7.5	8.7	9.7	4.7	6.6	8.1	9.3	10.4	3.1	4.4	5.3	6.2	6.9
E10	B10	6.4	9.1	11.1	12.8	14.3	6.0	8.5	10.4	12.0	13.4	6.4	9.1	11.1	12.8	14.4	4.2	6.0	7.3	8.5	9.4
E14	B14	9.1	12.9	15.8	18.2	20.3	8.5	12.0	14.7	17.0	18.9	9.1	12.9	15.8	18.2	20.4	6.0	8.5	10.4	12.0	13.4
E19	B19	13.9	19.8	24.2	28.0	31.4	13.0	18.4	22.6	26.1	29.2	14.0	19.8	24.3	28.1	31.4	9.2	13.0	16.0	18.5	20.7
E25	B25	23.8	33.8	41.4	47.8	53.5	22.2	31.5	38.6	44.6	49.9	23.9	33.8	41.4	47.9	53.6	15.7	22.2	27.3	31.5	35.3
E35	—	38.9	56.8	70.9	83.0	93.7	36.3	53.0	66.2	77.4	87.4	39.0	56.9	71.0	83.1	93.8	25.6	37.3	46.6	54.5	61.5
E42	—	73.5	104	127	147	164	68.6	96.9	119	137	153	73.6	104	127	147	165	48.5	68.5	83.9	96.9	108

TYPE NUMBER		TONS OF REFRIGERATION**																			
“E” SERIES VALVES	“A” & “B” SERIES VALVES	404A					407C					502					507				
		PRESSURE DROP – psi*																			
		1	2	3	4	5	1	2	3	4	5	1	2	3	4	5	1	2	3	4	5
E3	A3	0.6	0.9	1.1	1.2	1.4	0.8	1.2	1.5	1.7	1.9	0.6	0.8	1.0	1.2	1.4	0.6	0.8	1.0	1.2	1.4
E5	—	1.1	1.5	1.9	2.1	2.4	1.5	2.1	2.6	3.0	3.4	1.0	1.5	1.8	2.1	2.4	1.0	1.5	1.8	2.1	2.4
E6	B6	1.9	2.7	3.3	3.8	4.2	2.6	3.7	4.5	5.2	5.8	1.9	2.6	3.2	3.7	4.1	1.9	2.6	3.2	3.7	4.1
E9	B9	3.1	4.4	5.4	6.2	6.9	4.3	6.1	7.4	8.6	9.6	3.0	4.3	5.2	6.0	6.8	3.0	4.3	5.2	6.0	6.7
E10	B10	4.2	6.0	7.3	8.5	9.5	5.9	8.3	10.2	11.8	13.2	4.2	5.9	7.2	8.3	9.3	4.2	5.9	7.2	8.3	9.3
E14	B14	6.0	8.5	10.4	12.0	13.4	8.4	11.8	14.5	16.7	18.7	5.9	8.4	10.2	11.8	13.2	5.9	8.3	10.2	11.8	13.2
E19	B19	9.2	13.1	16.0	18.5	20.7	12.8	18.2	22.3	25.8	28.8	9.0	12.8	15.7	18.2	20.3	9.0	12.8	15.7	18.1	20.3
E25	B25	15.7	22.3	27.4	31.6	35.4	21.9	31.0	38.0	44.0	49.2	15.5	21.9	26.8	31.0	34.7	15.4	21.8	26.8	30.9	34.6
E35	—	25.5	37.3	46.5	54.4	61.4	35.6	52.0	64.8	75.9	85.7	25.3	36.9	46.0	53.8	60.8	25.1	36.6	45.6	53.4	60.3
E42	—	48.6	68.8	84.2	97.2	109	67.6	95.6	117	135	151	47.7	67.4	82.5	95.3	107	47.6	67.3	82.4	95.1	106

\*Do not use below 1 psi pressure drop, except Types E3 and A3 valves. \*\*Capacities are based on 40°F evaporator and 100°F liquid. Valve types whether Normally Closed or Normally Open have the same capacities, i.e., B10 or OB10, E10 or OE10. Solenoid valves for glycol or brine applications – consult Sporlan, Washington, MO.

For complete information on solenoids – liquid, suction or discharge gas capacities – see your Sporlan Wholesaler, our website at [www.sporlan.com](http://www.sporlan.com), or write Sporlan and request Bulletin 30-10.

# SOLENOID VALVES

22, 134a, 401A, 402A, 404A, 407C, 502, 507

## Specifications

TYPE NUMBER						CONNECTIONS Inches	PORT SIZE Inches	MOPD psi AC	WATTS
"E" SERIES EXTENDED CONNECTIONS			"A" & "B" SERIES VALVES						
WITHOUT MANUAL LIFT STEM		WITH MANUAL LIFT STEM	WITHOUT MANUAL LIFT STEM		WITH MANUAL LIFT STEM				
Normally Closed	Normally Open	Normally Closed	Normally Closed	Normally Open	Normally Closed				
—	—	—	A3P1	—	—	3/8 NPT Female	.101	300	10
—	—	—	A3F1	—	—	1/4 SAE Flare			
E3S120	—	—	A3S1	—	—	1/4 ODF Solder			
E3S130	—	—	A3S1	—	—	3/8 ODF Solder	.150	300	10
E5S120	—	—	—	—	—	1/4 ODF Solder			
E5S130	—	—	—	—	—	3/8 ODF Solder			
—	—	—	B6P1	—	MB6P1	3/8 NPT Female	3/16	300	10
—	—	—	B6F1	—	MB6F1	3/8 SAE Flare			
E6S130	—	ME6S130	B6S1	—	MB6S1	3/8 ODF Solder			
E6S140	—	ME6S140	B6S1	—	MB6S1	1/2 ODF Solder	9/32	*300	15
—	—	—	B9P2	OB9P2	MB9P2	3/8 NPT Female			
—	—	—	B9F2	OB9F2	MB9F2	3/8 SAE Flare			
E9S230	OE9S230	ME9S230	—	—	—	3/8 ODF Solder	5/16	*300	15
E9S240	OE9S240	ME9S240	B9S2	OB9S2	MB9S2	1/2 ODF Solder			
—	—	—	B10F2	—	MB10F2	1/2 SAE Flare			
E10S240	OE10S240	ME10S240	—	—	—	1/2 ODF Solder	7/16	*300	15
E10S250	OE10S250	ME10S250	B10S2	—	MB10S2	5/8 ODF Solder			
—	—	—	B14P2	OB14P2	MB14P2	1/2 NPT Female			
E14S250	OE14S250	ME14S250	B14S2	OB14S2	MB14S2	5/8 ODF Solder	19/32	*300	15
—	—	—	B19P2	OB19P2	—	3/4 NPT Female			
E19S250	OE19S250	ME19S250	B19S2	OB19S2	MB19S2	5/8 ODF Solder			
E19S270	OE19S270	ME19S270	B19S2	OB19S2	MB19S2	7/8 ODF Solder	25/32	*300	15
—	—	—	B25P2	—	MB25P2	1 NPT Female			
E25S270	OE25S270	ME25S270	B25S2	OB25S2	MB25S2	7/8 ODF Solder			
E25S290	OE25S290	ME25S290	B25S2	OB25S2	MB25S2	1-1/8 ODF Solder	1	300	10
E35S190	OE35S190	ME35S190	—	—	—	1-1/8 ODF Solder			
E35S1110	OE35S1110	ME35S1110	—	—	—	1-3/8 ODF Solder			
—	—	—	—	—	—	1-5/8 ODF Solder	1-5/16	*300	15
E42S2130	OE42S2130	ME42S2130	—	—	—	1-5/8 ODF Solder			
E42S2170	OE42S2170	ME42S2170	—	—	—	2-1/8 ODF Solder			

\*All normally open valves are rated at 275 psi, except OE35...300 psi.

### Maximum Rated Pressures

Valve Type E42 Series – 450 psi  
All other valve types – 500 psi

### Interchangeability of Coils

**MKC-1** for Types A3, E3, B6, MB6, E5, E6, ME6, E35 and ME35 series. **MKC-2** for types B9, MB9, E9 and ME9 series through the E42 and ME42 series.

**OMKC-1** and **OMKC-2** Coil Assemblies are for use on Normally Open valves.

### Electrical Specifications

**Standard Coil Ratings** – MKC-1, OMKC-1, MKC-2 and OMKC-2: 24/50-60, 120/50-60, 208-240/50-60. Dual Voltage 4 Wire Coils – 120-208-240/50-60, slight additional cost.

Available with junction box or conduit boss at no extra charge. Also, DIN coils are available for an additional cost. For other voltages and cycles consult Sporlan.

### Nomenclature/Ordering Instructions

Be sure to specify Valve Type, Connections, Voltage and Cycles.

<b>M</b>	<b>E</b>	<b>10</b>	<b>S</b>	<b>2</b>	<b>5</b>	<b>0</b>	<b>S</b>	<b>HP</b>
Manual Lift Stem	Design Series	Port Size in 1/32"	Connections Solder	Coil Size ①②	Connection Size in 1/8"	*Connections 0 - ODF x ODF 1 - ODF x ODM 2 - ODM x ODF 3 - ODM x ODM	Coil Connection S - Spade E - DIN 43650A	for R-410A only
① The MKC-1, OMKC-1, MKC-2 and OMKC-2 are fungus proof and meet MIL-I-631C.	* Standard connections are ODF inlet x ODF outlet on "E" Series valves. Minimum quantities may be required for other connections.							
② The standard MKC-1 and MKC-2 are class "F" rated.								
<b>O</b>	<b>D</b>	<b>M</b>	<b>B</b>	<b>25</b>	<b>S</b>	<b>2</b>	<b>*</b>	<b>S</b>
Normally Open	Disc Type *D - Direct Connected C - see page 34	Manual Lift Stem	Design or Series A, B, & W Series	Port Size in 1/32"	Connections P - Pipe F - SAE Flare S - ODF Solder	Coil Size ①, ②	Overall Length	Coil Connection S - Spade E - DIN 43650A

The above prefixes may be added to basic valve type number (B25S2) to request special features.

Normally open valves available in B9, E9 through E42 series only, and require OMKC-2 Coil Assembly.

\*D - Direct connected assembly is available on B14 series valve. Minimum quantity order may be required.

For complete information see your Sporlan Wholesaler, our website at [www.sporlan.com](http://www.sporlan.com), or write Sporlan and request Bulletin 30-10.

# ▼ SOLENOID VALVES

410A

## E6S130-HP



R-410A valves with ODF solder connections are available from Sporlan in many different voltage and cycle ratings. Standard coils are listed in the specifications table at right.

Solenoid coils are available with either an integral junction box, a 1/2" conduit boss or DIN connector. Female DIN connector assemblies are also available.

**MOPD: 450 MRP: 700**

## Specifications

VALVE SERIES	CONNECTIONS Inches	PORT SIZE Inches	STANDARD COIL RATINGS		
			KIT	VOLTS/CYCLES	WATTS
E5S130-HP	3/8 ODF	.150	MKC-1	24/50-60 120/50-60 208-240/50-60 120-208-240/50-60	10
ME6S130-HP	3/8 ODF	3/16	MKC-1		
ME9S240-HP	1/2 ODF	9/32	MKC-2		15
ME14S250-HP	5/8 ODF	7/16			
ME19S270-HP	7/8 ODF	19/32			
ME25S290-HP	1-1/8 ODF	25/32	MKC-1	10	
ME35S190-HP	1-1/8 ODF	1			
ME35S1110-HP	1-3/8 ODF	1			

## Capacities For R-410A – Tons

VALVE SERIES	CAPACITIES – TONS OF REFRIGERATION															
	LIQUID					DISCHARGE GAS						SUCTION GAS				
	PRESSURE DROP ACROSS VALVE – psi*											1 psi – PRESSURE DROP and EVAPORATING TEMPERATURE				
	1	2	3	4	5	2	5	10	20	50	100	40°F	20°F	0°F	-20°F	-40°F
E5S130-HP	1.52	2.16	2.66	3.08	3.45	0.54	0.86	1.22	—	3.02	3.75	—	—	—	—	—
ME6S130-HP	2.73	3.84	4.68	5.35	6.02	1.0	1.57	2.2	3.50	5.1	6.14	0.50	0.40	0.32	0.24	0.18
ME9S240-HP	4.44	6.27	7.66	8.76	9.86	1.59	2.52	3.57	5.70	7.74	10.2	0.80	0.63	0.50	0.38	0.28
ME14S250-HP	8.64	12.2	14.9	17.1	19.2	3.13	4.93	6.96	11.1	16.2	20.9	1.56	1.24	0.98	0.75	0.56
ME19S270-HP	13.2	18.7	22.9	26.3	29.7	4.71	7.47	10.6	17.0	24.0	31.2	2.33	1.85	1.45	1.11	0.83
ME25S290-HP	22.5	31.9	39.2	49.9	50.6	7.92	12.5	17.7	25.0	38.3	49.9	3.95	3.14	2.46	1.89	1.41
ME35S190-HP	36.7	53.5	66.8	77.5	88.2	12.0	19.8	28.9	42.2	67.5	89.1	5.62	4.39	3.37	2.53	1.85
ME35S1110-HP	36.7	53.5	66.8	77.5	88.2	12.0	19.8	28.9	42.2	67.5	89.1	5.62	4.39	3.37	2.53	1.85

\* Do not use below 1 psi (0.07 bar) pressure drop.

E5S130-HP – contact Sporlan Division for suction gas capacities.

Liquid capacities based on 100°F (38°C) liquid temperature, 40°F (5°C) evaporator temperature. For other liquid line temperatures use liquid correction factors below. Maximum Operating Pressure Differential (MOPD) for the AC coil is 450 psid (31 bar). Maximum Rated Pressure (MRP) = 700 psig (48.3 bar).

Discharge capacities based on 100°F (38°C) condensing temperature, isentropic compression plus 50°F (28°C), 40°F (5°C) evaporator and 65°F (18.3°C) suction gas. For capacities at other conditions, consult Sporlan Division of Parker, Washington, MO.

# ▼ BUILT-IN CHECK VALVE SERIES

22, 134a, 401A, 402A, 404A, 407C, 502, 507

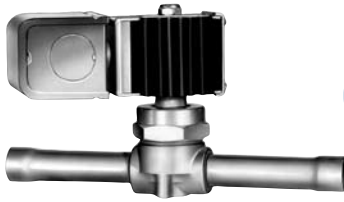

**CE14S250**

The check valve disc also requires a modification in the stem and plunger assembly. Therefore, the disc and stem and plunger assembly must be changed to convert a standard solenoid valve to one with a built-in check valve. Internal parts kits are available for solenoid valves with the built-in check valve. See Bulletin 122, Replacement Parts.

## For Supermarkets

See Figure 1, on the following page. For reverse gas defrost, a liquid line solenoid valve can be installed with a check valve in parallel, to allow reverse flow to the liquid header. This adds the expense of labor and materials. Or, a Sporlan liquid line solenoid valve with the built-in check valve feature can be installed, saving time and money.

## For Heat Pumps

This valve may be used on some heat pump applications when sized correctly. (Refer to capacities at 40°F evaporator temperature, see below.)

**Extreme care should be taken when brazing connections to avoid damage to internal synthetic parts.**

A solenoid valve with a built-in check valve is designed to replace a liquid line solenoid valve in parallel with a check valve for reverse flow. This valve may be applied in the liquid line of a supermarket case for positive shutoff during pumpdown control, while allowing full flow in the reverse direction during reverse gas defrost. It may also be used in the liquid line of a heat pump to prevent migration of refrigerant to the outdoor unit during the heating mode, while allowing full flow in the reverse direction during the cooling mode. **Note: This valve will not close in the reverse flow/cooling mode.**

The check ball is small and inserted into the pilot port of the disc. When the valve is energized for operation in the refrigeration flow direction, the pressure on top of the disc is bled off through the pilot port and the disc raises. When the evaporator goes into defrost or the heat pump switches to the heating mode, the solenoid valve is energized. The reverse flow causes the check ball to close the pilot port from the bottom, pushing the disc up, fully opening the valve.

## Nomenclature/Ordering Instructions

When ordering complete valves, specify Valve Type, Connections, Voltage and Cycles.  
 When ordering Body Assembly, specify Valve Type and Connections.  
 When ordering Coil Assembly ONLY, specify Coil Type, Voltage and Cycles.

<b>C</b>	<b>E</b>	<b>10</b>	<b>S</b>	<b>2</b>	<b>5</b>	<b>0</b>	<b>S</b>
Check Valve Feature	Design Series	Port Size in 1/32"	Connections Solder	Coil Size ①, ②	Connection Size in 1/8"	*Connections 0 - ODF x ODF 1 - ODF x ODM 2 - ODM x ODF 3 - ODM x ODM	Coil Connection S - Spade E - DIN 43650A

- ① The MKC-1, 0MKC-1, MKC-2 and 0MKC-2 are fungus proof and meet MIL-I-631C.
- ② The standard MKC-1 and MKC-2 are class "F" rated.
- \* Standard connections are ODF inlet x ODF outlet on "E" Series valves. Minimum quantities may be required for other connections.

**Example: CE14S250 120-50/60**  
**Valve with Manual Lift Stem: CME10S250**  
**Kit: KS-CB14/CE14 or KS-CB10/CE10**

## Specifications For Reverse Refrigeration Flow, Liquid Line Capacity – Tons\*\*

VALVE TYPE	CONNECTIONS Inches	R-22 3 psi		R-134a 2 psi		R-401A 2 psi		R-402A 3 psi		R-404A 3 psi		R-407C 3 psi		R-502 3 psi		R-507 3 psi	
		40	0	40	0	40	0	40	0	40	0	40	0	40	0	40	0
		EVAPORATOR °F															
CME9S230, CME9S240	3/8, 1/2 ODF	6.6	6.2	5.1	4.6	5.5	5.0	—	3.9	—	3.9	6.1	5.6	—	3.9	—	3.8
CME10S250	5/8 ODF	8.1	7.6	6.2	5.6	6.6	6.1	—	4.8	—	4.8	7.4	6.8	—	4.7	—	4.7
CB14S2, CE14S250	5/8 ODF	12.9	12.2	10.2	9.3	11.0	10.2	—	7.7	—	7.8	12.0	11.0	—	7.6	—	7.6
CME19S270	7/8 ODF	9.3	8.8	6.2	5.6	6.6	6.1	—	5.4	—	5.1	8.2	7.5	—	5.5	—	5.1

\*\* Valve sizing should be based on expected reverse liquid flow condensing capabilities of the evaporator(s) being defrosted.  
 + Due to flow restrictions, C(M)E19 model capacity does not surpass C(M)E14 models until pressure drop exceeds 10 psi.  
 See page 31 for Forward Refrigerant Flow.  
 Liquid capacities shown in the above table are based on 100°F liquid temperature entering the valves.

# ▼ BUILT-IN CHECK VALVE SERIES

22, 134a, 401A, 402A, 404A, 407C, 502, 507

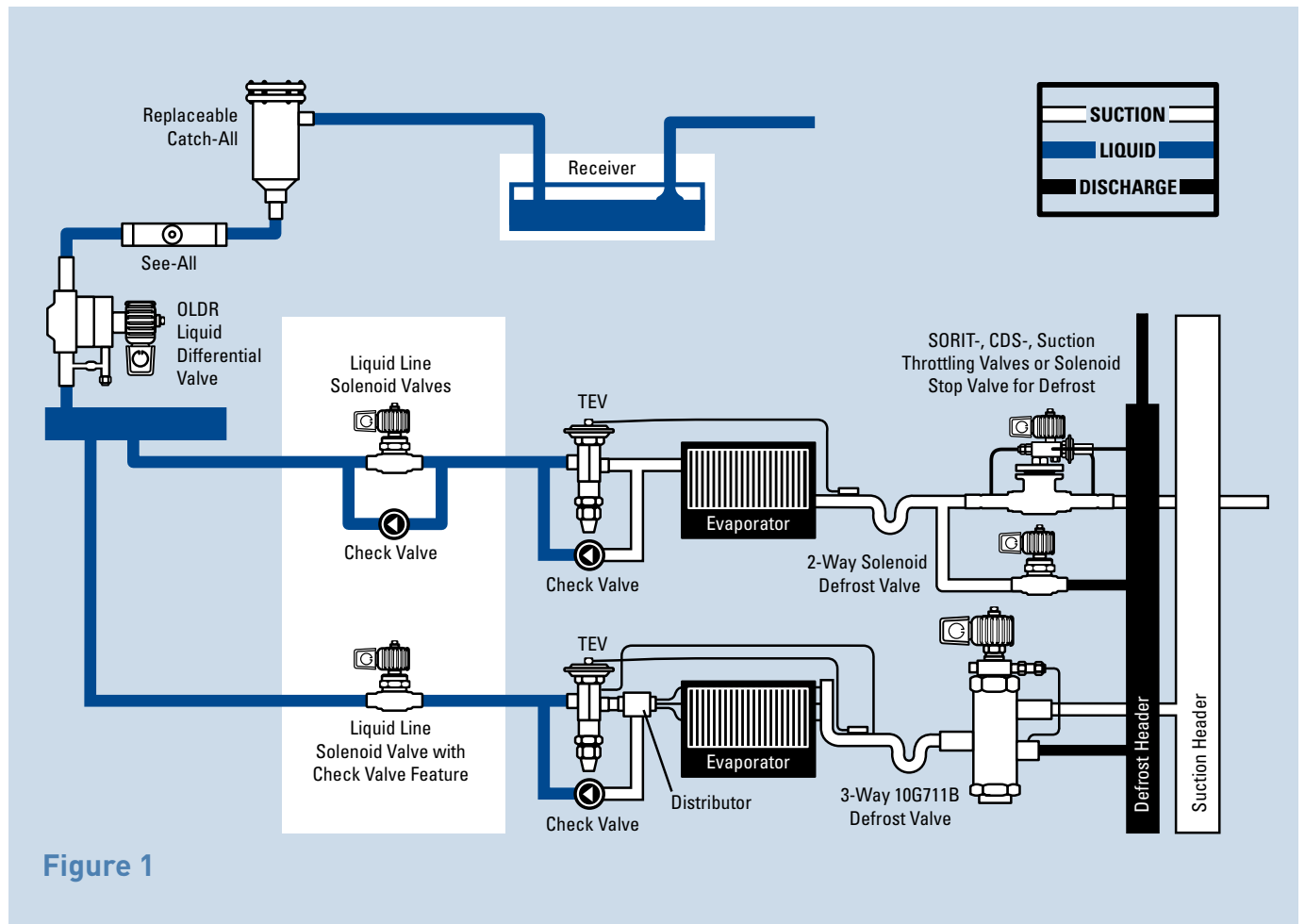

Figure 1

## INDUSTRIAL SOLENOID VALVES

FOR AIR, WATER, STEAM and LIGHT OIL



W3P1



R184P1

### Disc Type – Application

These valves are suitable for most types of industrial applications. Ideal for water, light oils, air lines to chucking devices, steam lines, etc. Use the **disc type** valves for high temperature and steam applications up to 25 psia. Use the teflon **diaphragm type** valve for high temperature and steam applications over 5 psia (225°F) but do not exceed 10 psia (240°F).

The **W3P1** is the ideal size for use on air chucking devices. Generally, a very tight seat is required for this type of application. This can be achieved by using a neoprene seat in the **W3P1** in place of the standard teflon. **To order specify RW3P1.**

### Diaphragm Type – Application

Suitable for most types of industrial applications. Ideal for water, light oils, air lines to chucking devices, steam lines, etc. Use the **disc type** valves for high temperature and steam applications up to 25 psig. Use the teflon **diaphragm type** valve for high temperature and steam applications over 5 psia (225°F) but do not exceed 10 psia (240°F).

Diaphragm type industrial solenoid valves are tight seating in applications of normal differential pressure. For applications where differential pressures in the closed position are below 5 psi, a Buna-N diaphragm is recommended in place of the standard teflon diaphragm. **To order specify BR184P1.**

### Specifications

①TYPE	STANDARD CONNECTIONS Inches	PORT SIZE Inches	MOPD psi	CAPACITIES						STANDARD COIL RATINGS	
				AIR – CFM		WATER – GPM		STEAM – PPH – 5 psi ΔP		WATTS	COIL
				5 psi ΔP	10 psi ΔP	5 psi ΔP	20 psi ΔP	INLET PRESSURE			
W3P1	1/4 NPT Female	.109	150	2.4	3.4	0.5	1.2	7.5	8.6	10	MKC-1
W6P1	3/8 NPT Female	3/16		7.25	10.8	2.2	4.5	23.0	26.0		
W14P2	1/2 NPT Female	7/16		24.2	39.5	5.9	12.7	77.0	88.0	15	MKC-2
W19P2	3/4 NPT Female	19/32		41.0	61.0	8.8	19.1	133	151		
W25P2	1 NPT Female	25/32		74.0	114	14.5	32.5	222	298		

①TYPE	STANDARD CONNECTIONS Inches	PORT SIZE Inches	MOPD psi	CAPACITIES						STANDARD COIL RATINGS	
				AIR – CFM		WATER – GPM		STEAM – PPH – 5 psi ΔP		WATTS	COIL
				5 psi ΔP	10 psi ΔP	5 psi ΔP	20 psi ΔP	INLET PRESSURE			
R183P1	3/8 NPT Female	9/16	150	32.5	47.4	8.1	16.1	105	152	10	MKC-1
BR183P1											
R184P1	1/2 NPT Female	9/16	150	37.0	54.0	9.2	18.3	119	173		
BR184P1											
R246P1	3/4 NPT Female	3/4	150	52.3	76.4	12.9	25.8	168	245		
BR246P1											

① "R" type valves have Teflon diaphragm – 240°F Max. Fluid Temperature; "BR" type valves have Buna-N diaphragm – 225°F Max. Fluid Temperature.

Use a **SPORLAN** strainer ahead of every industrial solenoid valve.

For complete information see your Sporlan Wholesaler, our website at [www.sporlan.com](http://www.sporlan.com), or write Sporlan and request Bulletin 30-10.

## ▼ THREE WAY HEAT RECLAIM VALVES

Sporlan Heat Reclaim Valves are tight synthetic seating three way valves designed specifically to divert hot gas from the normal to auxiliary condenser.

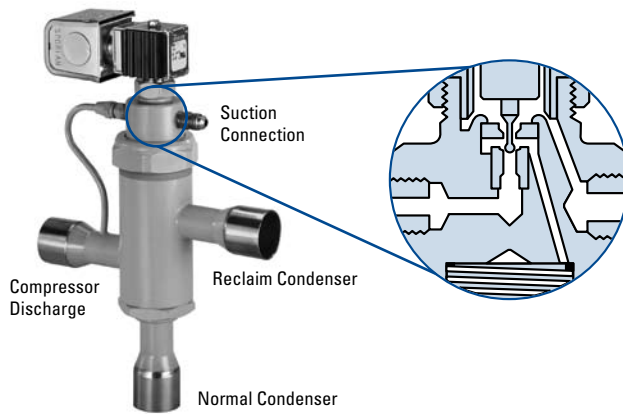

### “C” Type

**Normal (Outdoor) Condenser – De-energized** – With the pilot valve de-energized, high side pressure is prevented from entering cavity above the piston-seat assembly. At the same time the upper pilot port is opened to suction pressure. The resulting pressure differential across the piston moves the piston-seat assembly to close the reclaim (upper) main port. The non bleed piston prevents high to low side bleed with the system operating in the normal condenser mode.

### “B” and “C” Type

**Reclaim (Reheat) Condenser – Energized** – When the pilot valve is energized, high side pressure is permitted to flow thru the lower pilot port. At the same time the upper pilot port is closed to suction. High side pressure on top of the piston moves the piston-seat assembly to close the normal condenser port and open the reclaim (upper) main port. With the upper pilot port closed there is no high to low side bleed loss with the system operating in the reclaim mode.

### Operation “B” Type

**Normal (Outdoor) Condenser – De-energized** – With the pilot valve de-energized, high side pressure is prevented from entering the cavity above the piston-seat assembly. At the same time the upper pilot port is opened to suction pressure. The resulting pressure differential across the piston moves the piston-seat assembly to close the reclaim (upper) main port. When the upper pilot port is open, the cavity above the piston is open to suction. Pump out of the reclaim condenser is controlled by the bleed rate through the piston. After the reclaim condenser has been pumped out, and the valve continues to operate in the normal condenser mode, **all flow ceases**, thus eliminating high to low side bleed and the resulting capacity loss.

### Heat Reclaim Systems

- with Head Pressure Control
- with Split Condenser Control

When employing heat reclaim on a refrigeration system, the addition of head pressure controls is important not only to maintain liquid pressure at the expansion valve inlet, but also to assure availability of quality hot gas at the reclaim heat exchanger. Split condenser controls are important to minimize the required refrigerant charge for wintertime operation. And, integral check valves are important to minimize installation costs. (See Bulletin 30-20.)

### Specifications

TYPE	CONNECTION ODF SOLDER Inches	PORT SIZE	MKC-1 COIL		STANDARD COIL RATINGS	
			MOPD psi	MAXIMUM RATED PRESSURE psi	VOLTS/CYCLES	WATTS
			AC			
B5D5B, B5D5C	5/8	3/4	400	650	24/50-60 120/50-60 208-240/50-60 120-208-240/50-60	10
8D7B, 8D7C	7/8		300			
8D7B-HP, 8D7C-HP	7/8		400			
8D9B, 8D9C	1-1/8		300			
8D9B-HP, 8D9C-HP	1-1/8		400			
12D11B, 12D11C	1-3/8	1-1/4	300	450		
12D13B, 12D13C	1-5/8					
12D17B	2-1/8					
16D17B, 16D17C	2-1/8					

Available with junction box or conduit boss at no extra charge. For other voltages and cycles, consult Sporlan, Washington, MO.

### Selection

- For a given refrigerant, select a valve having a port size with capacity most closely matching the evaporator maximum load requirements in tons at the design evaporator temperature. Take into account the allowable pressure drop across the valve port.
- Select the proper coil assembly for the valve type and match the voltage requirements. All AC voltage options are available. For voltages not listed in coil specification, consult Bulletin 30-10, or Sporlan, Washington, MO.

# THREE WAY HEAT RECLAIM VALVES

22, 134a, 401A, 402A, 404A, 407C, 502, 507

## Capacities – Tons

Capacities are based on 100°F condensing temperature isentropic compression plus 50°F, evaporator temperature as shown plus 25°F superheat suction gas.

EVAPORATOR TEMP. °F	REFRIGERANT																							
	22								134a								401A							
	psi – PRESSURE DROP																							
	2				4				2				4				2				4			
	B5D	8D	12D	16D	B5D	8D	12D	16D	B5D	8D	12D	16D	B5D	8D	12D	16D	B5D	8D	12D	16D	B5D	8D	12D	16D
40	4.7	10.1	29.1	70.1	6.6	14.2	41.9	100.0	4.0	10.1	29.1	70.1	5.5	11.8	34.6	83.1	4.1	8.7	24.6	59.3	5.7	12.1	35.4	85.1
30	4.7	9.9	28.6	68.7	6.5	13.9	41.1	98.6	3.9	9.9	28.6	68.7	5.4	11.5	33.8	81.1	4.0	8.5	24.1	58.0	5.5	11.9	34.6	83.2
20	4.6	9.7	28.0	67.4	6.3	13.6	40.3	96.7	3.8	9.7	28.0	67.4	5.2	11.2	32.9	79.1	3.9	8.3	23.5	56.6	5.4	11.6	33.8	81.3
10	4.5	9.5	27.4	66.0	6.2	13.4	39.4	94.6	3.7	9.5	27.4	66.0	5.1	10.9	32.0	77.0	3.8	8.1	22.9	55.3	5.3	11.3	33.0	79.3
0	4.4	9.3	26.8	64.5	6.1	13.1	38.5	92.5	3.6	9.3	26.8	64.5	5.0	10.6	31.1	74.8	3.7	7.9	22.3	53.8	5.1	11.0	32.1	77.2
-10	4.3	9.1	26.2	63.0	5.9	12.8	37.6	90.4	3.5	9.1	26.2	63.0	4.8	10.3	30.2	72.7	3.6	7.7	21.7	52.4	5.0	10.7	31.3	75.2
-20	4.2	8.9	25.5	61.5	5.8	12.5	36.7	88.2	3.4	8.9	25.5	61.5	4.7	10.0	29.3	70.5	3.5	7.5	21.1	50.9	4.9	10.4	30.4	73.1
-30	4.1	8.7	24.9	59.9	5.7	12.1	35.8	85.9	3.3	8.7	24.9	59.9	4.5	9.7	28.4	68.2	3.4	7.2	20.5	49.4	4.7	10.1	29.5	70.9
-40	4.0	8.4	24.2	58.2	5.5	11.8	34.8	83.6	3.2	8.4	24.2	58.2	4.4	9.4	27.5	66.0	3.3	7.0	19.9	47.9	4.6	9.8	28.6	68.8

EVAPORATOR TEMP. °F	REFRIGERANT																							
	402A								404A								407C							
	psi – PRESSURE DROP																							
	2				4				2				4				2				4			
	B5D	8D	12D	16D	B5D	8D	12D	16D	B5D	8D	12D	16D	B5D	8D	12D	16D	B5D	8D	12D	16D	B5D	8D	12D	16D
40	4.1	8.8	25.7	61.7	5.7	12.3	36.9	88.5	4.2	9.0	26.3	63.3	5.8	12.6	37.9	90.8	4.7	10.0	28.8	69.3	6.5	14.0	41.4	99.4
30	4.0	8.5	25.0	60.1	5.5	12.0	36.0	86.2	4.1	8.8	25.6	61.6	5.7	12.3	36.9	88.3	4.6	9.8	28.1	67.6	6.3	13.7	40.4	97.0
20	3.9	8.3	24.3	58.4	5.4	11.6	35.0	83.8	4.0	8.5	24.9	59.8	5.5	11.9	35.8	85.8	4.5	9.5	27.4	66.0	6.2	13.3	39.4	94.6
10	3.8	8.1	23.6	56.7	5.2	11.3	33.9	81.3	3.8	8.3	24.1	58.0	5.3	11.6	34.7	83.2	4.3	9.3	26.7	64.2	6.0	13.0	38.4	92.1
0	3.6	7.8	22.8	54.9	5.0	10.9	32.9	78.8	3.7	8.0	23.3	56.1	5.2	11.2	33.6	80.4	4.2	9.0	25.9	62.4	5.9	12.6	37.3	89.6
-10	3.5	7.5	22.1	53.0	4.9	10.6	31.7	76.1	3.6	7.7	22.5	54.1	5.0	10.8	32.4	77.6	4.1	8.8	25.2	60.6	5.7	12.3	36.2	87.0
-20	3.4	7.3	21.3	51.2	4.7	10.2	30.6	73.4	3.5	7.4	21.7	52.1	4.8	10.4	31.2	74.8	4.0	8.5	24.4	58.8	5.5	11.9	35.1	84.3
-30	3.3	7.0	20.5	49.2	4.5	9.8	29.5	70.6	3.3	7.1	20.8	50.1	4.6	10.0	30.0	71.8	3.9	8.2	23.6	56.9	5.4	11.5	34.0	81.6
-40	3.1	6.7	19.7	47.2	4.3	9.4	28.3	67.8	3.2	6.8	20.0	48.0	4.4	9.6	28.7	68.8	3.7	8.0	22.8	54.9	5.2	11.1	32.8	78.8

EVAPORATOR TEMP. °F	REFRIGERANT																							
	410A								502								507							
	psi – PRESSURE DROP																							
	2				4				2				4				2				4			
	B5D	8D	12D	16D	85D	8D	12D	16D	B5D	8D	12D	16D	B5D	8D	12D	16D	B5D	8D	12D	16D	B5D	8D	12D	16D
40	5.6	12.0	—	—	7.8	16.9	—	—	3.7	8.0	23.4	56.2	5.17	11.2	33.7	80.7	4.1	8.8	25.7	61.6	5.7	12.3	36.9	88.4
30	5.5	11.8	—	—	7.7	16.6	—	—	3.6	7.8	22.8	54.9	5.05	10.9	32.8	78.7	4.0	8.5	25.0	60.0	5.5	11.9	35.9	86.1
20	5.4	11.6	—	—	7.5	16.3	—	—	3.5	7.6	22.2	53.4	4.92	10.6	32.0	76.7	3.9	8.3	24.3	58.3	5.4	11.6	34.9	83.6
10	—	—	—	—	—	—	—	—	3.4	7.4	21.6	52.0	4.78	10.4	31.1	74.5	3.7	8.0	23.5	56.5	5.2	11.3	33.8	81.1
0	—	—	—	—	—	—	—	—	3.3	7.2	21.0	50.4	4.65	10.1	30.2	72.4	3.6	7.8	22.8	54.7	5.0	10.9	32.7	78.5
-10	—	—	—	—	—	—	—	—	3.2	7.0	20.3	48.9	4.50	9.74	29.2	70.1	3.5	7.5	22.0	52.8	4.9	10.5	31.6	75.8
-20	—	—	—	—	—	—	—	—	3.1	6.7	19.7	47.3	4.36	9.43	28.3	67.8	3.4	7.2	21.2	50.9	4.7	10.1	30.5	73.1
-30	—	—	—	—	—	—	—	—	3.0	6.5	19.0	45.6	4.21	9.10	27.3	65.5	3.3	7.0	20.4	49.0	4.5	9.8	29.3	70.3
-40	—	—	—	—	—	—	—	—	2.9	6.3	18.3	44.0	4.06	8.77	26.3	63.1	3.1	6.7	19.6	47.0	4.3	9.4	28.1	67.5

For complete information see your Sporlan Wholesaler, our website at [www.sporlan.com](http://www.sporlan.com), or write Sporlan and request Bulletin 30-20.

## Nomenclature/Ordering Instructions

When ordering complete valves, specify Valve Type, Voltage and Cycles. When ordering Valve Body ONLY, specify Valve Type. When ordering Coil Assembly ONLY, specify Coil Type, Voltage and Cycles. **Example: MKC-1 120/50-60; MKC-2 120/50-60.**

<b>MKC</b>	—	<b>1</b>	—	<b>120</b>	/	<b>50-60</b>
Coil Type		Size		Voltage		Cycles



# THE PERFECT FILTER-DRIER

12, 22, 134a, 404A,  
407C, 410A, 502, 507  
Also Compatible with Refrigerants  
123, 124, 125, 401A & B, 402A & B, 408A, 409A

The universal acceptance of the **Catch-All® Filter-Drier** is due to its unique molded porous core, consisting of a blend of highly effective desiccants. The quality features built into it assure years of service on any refrigeration system.

**MOISTURE** – The **Catch-All Filter-Drier** removes moisture from the refrigerant by adsorbing and retaining it deep within the desiccant granules. The blend of desiccants used in the **Catch-All Filter-Drier** are specially formulated for exceptional water removal.

**FOREIGN MATTER** – The **Catch-All Filter-Drier** will filter out scale, solder particles, carbon, sludge, dirt or any other foreign matter with negligible pressure drop. Fine particles that would go through an ordinary strainer are removed down to a minimum size in one pass filtration. The large filtering area of the **Catch-All Filter-Drier** core permits it to collect a large amount of dirt without plug up.

**ACID** – The **Catch-All Filter-Drier** is unexcelled in acid removal ability. The hydrochloric, hydrofluoric, and various organic acids

are adsorbed and held by the desiccant in a manner similar to the adsorption of moisture. Tests have demonstrated that the **Catch-All Filter-Drier** has superior acid removal ability when compared to competitive driers. This ability, along with its excellent ability to clean up the oil, is responsible for the excellent field performance in cleaning up severely contaminated systems.

**OIL SLUDGE AND VARNISH** – Even the best refrigeration oils break down to produce varnish, sludge and organic acids. Only the **Catch-All Filter-Drier** is capable of removing these products of oil decomposition.

**SPECIAL APPLICATIONS** – A special “HH” core **Catch-All Filter-Drier** is available to remove wax which frequently causes difficulty on low temperature refrigeration systems. For cap tube systems, use the C-032-CAP or C-032-CAP-T **Catch-All** which has fittings suitable for attaching to any size capillary tube.

*Remember...It's the CORE that counts!*



## Sealed Type – Liquid Line And Suction Line Specifications

"C" SERIES LIQUID LINE TYPE		SUCTION LINE TYPE	CONNECTION SIZE Inches	VOLUME of DESICCANT Cubic Inches	OVERALL LENGTH Inches		SOLDER SOCKET DEPTH Inches	DIAMETER of BODY Inches
SAE FLARE	ODF SOLDER	ODF SOLDER			SAE FLARE	ODF SOLDER		
C-032	C-032-S	—	1/4	3	4.19	3.81	0.38	1.75
—	C-032-CAP C-032-CAP-T	—	Extended 1/4 Male		—	5.81	—	
C-032-F	—	—	1/4 Male - Inlet 1/4 Female - Outlet		3.81	—	—	
C-032-FM	—	—	1/4 Female - Inlet 1/4 Male - Outlet		3.81	—	—	
C-033	C-033-S	—	3/8	5	4.69	3.88	0.44	2.44
C-052	C-052-S C-0525-S	—	1/4 5/16		4.75	4.19	0.38	
—	—	—	—		—	4.38	0.44	
C-052-F	—	—	1/4 Male - Inlet 1/4 Female - Outlet		4.19	—	—	
C-052-FM	—	—	1/4 Male - Inlet 1/4 Female - Outlet	4.19	—	—	—	
C-053	C-053-S	—	3/8	9	5.19	4.31	0.44	2.62
C-082	C-082-S	—	1/4		5.62	5.12	0.38	
—	C-0825-S	—	5/16		—	5.31	0.44	
C-083	C-083-S	C-083-S-T-HH	3/8		6.06	5.25	0.44	
C-084	C-084-S	C-084-S-T-HH	1/2	6.31	5.44	0.50	—	
C-162	C-162-S	—	1/4	16	6.25	5.75	0.38	3.00
—	C-1625-S	—	5/16		—	5.94	0.44	
C-163	C-163-S	—	3/8		6.75	5.88	0.44	
C-164	C-164-S	C-164-S-T-HH	1/2		6.94	6.00	0.50	
C-165	C-165-S	C-165-S-T-HH	5/8		7.25	6.31	0.62	
—	—	C-166-S-T-HH	3/4		—	6.75	0.62	
—	C-167-S	C-167-S-T-HH	7/8	—	6.93	0.75		
C-303	C-303-S	—	3/8	30	9.69	8.88	0.44	3.00
C-304	C-304-S	—	1/2		9.88	9.00	0.50	
C-305	C-305-S	C-305-S-T-HH	5/8		10.19	9.25	0.62	
—	C-306-S	C-306-S-T-HH	3/4		—	9.65	0.62	
—	C-307-S	C-307-S-T-HH	7/8		—	9.80	0.75	
—	C-309-S	C-309-S-T-HH	1-1/8		—	9.75	0.96	
C-413	—	—	3/8	41	9.56	—	—	3.50
C-414	C-414-S	—	1/2		9.94	9.05	0.50	
C-415	C-415-S	—	5/8		10.25	9.35	0.62	
—	C-417-S	C-417-S-T-HH	7/8		—	9.81	0.75	
—	C-419-S	C-419-S-T-HH	1-1/8	—	9.75	0.96	—	
—	—	C-437-S-T-HH	7/8	48	—	10.34	0.75	4.75
—	—	C-439-S-T-HH	1-1/8		—	10.74	0.94	
—	—	C-4311-S-T-HH	1-3/8		—	10.94	1.00	
—	—	C-4313-S-T-HH	1-5/8		—	10.94	1.06	
—	C-607-S	C-607-S-T-HH	7/8	60	—	16.00	0.75	3.00
—	C-609-S	C-609-S-T-HH	1-1/8		—	16.00	0.96	
COMPACT STYLE		C-144-S-TT-HH	1/2	14	—	4.14	0.50	4.44
		C-145-S-TT-HH	5/8		—	4.38	0.66	
		C-146-S-TT-HH	3/4		—	4.83	0.66	
		C-147-S-TT-HH	7/8		—	4.97	0.75	
		C-149-S-TT-HH	1-1/8		—	4.93	0.96	

UL and UL<sub>C</sub> Listed – Guide SMT-File No. SA-1756A & B. Maximum Rated Pressure of 650 psi, except for the C-140 Series rated at 450 psi and the C-430 Series rated at 500 psi. For complete information see your Sporlan Wholesaler, our website at [www.sporlan.com](http://www.sporlan.com), or write Sporlan and request Bulletin 40-10.

# Catch-All THE PERFECT FILTER-DRIER

22, 134a, 404A,  
407C, 410A, 507

## Replaceable Core Type

### ODF Solder Connections

The rugged construction of the Replaceable Core Catch-All has proven itself in the field for many years. The design features include:

1. The famous **molded porous core** for maximum contaminant removal. The core cannot swell, powder or pack – assuring ease of installation and removal.
2. The **bolt and nut attachment** of the end plate provides simple trouble-free installation.
3. The **internal** construction gives a one piece assembly and assures proper core alignment.
4. A **complete line** of fitting sizes – all with copper fittings.
5. **No plastic parts** are used – all internal parts are plated steel.
6. A **corrosion resistant powder paint** protects the exterior of the shell.



RCW-48



RC-4864



RCW-100



C-969-G



## Specifications

TYPE	CONNECTIONS ODF SOLDER Inches	OPTIONAL SECONDARY FILTER*	NUMBER of CORES or FILTER ELEMENTS	CORE PART NUMBER	VOLUME of DESICCANT Cubic Inches	FILTER ELEMENT PART NUMBER	MOUNTING BRACKETS	OVERALL LENGTH Inches
C-R424-G	1/2	—	1	RCW-42	42	—	A-175-1	9.00
C-R425-G	5/8	—	1	RCW-42	42	—	A-175-1	9.06
C-R427-G	7/8	—	1	RCW-42	42	—	A-175-1	9.44
C-485-G	5/8	FS-480	1	RCW-48, RC-4864 or RC-4864-HH	48	RPE-48-BD	A-685	9.15
C-487-G	7/8							9.30
C-489-G	1-1/8							9.50
C-4811-G	1-3/8							9.60
C-4813-G	1-5/8							9.60
C-967-G	7/8	FS-960	2	RCW-48, RC-4864 or RC-4864-HH	96	RPE-48-BD	A-685	14.84
C-969-G	1-1/8							15.04
C-9611-G	1-3/8							15.14
C-9613-G	1-5/8							15.14
C-1449-G	1-1/8							FS-1440
C-14411-G	1-3/8	20.68						
C-14413-G	1-5/8	20.68						
C-19211-G	1-3/8	FS-19200	4	RCW-48, RC-4864 or RC-4864-HH	192	RPE-48-BD	A-685	
C-19213-G	1-5/8							26.22
C-19217-G	2-1/8							26.22
C-30013-G	1-5/8	—	3	RCW-100, RC-10098 or RC-10098-HH	300	RPE-100	A-175-2	27.94
C-30017-G	2-1/8							28.06
C-40017-G	2-1/8	—	4	RCW-100, RC-10098 or RC-10098-HH	400	RPE-100	A-175-2	34.56
C-40021-G	2-5/8							34.75
C-40025-G	3-1/8							34.44
C-40029-G	3-5/8							34.81
C-40033-G	4-1/8							35.12
NPT PIPE CONNECTIONS								
C-484-PG	1/2	—	1	RCW-48,	48	RPE-48-BD	A-685	9.08
C-966-PG	3/4		2	RC-4864	96			14.67
C-1448-PG	1		3	or	144			20.42
C-19212-PG	1-1/2		4	RC-4864-HH	192			25.85
C-40016-PG	2	—	4	RCW-100, RC-10098 or RC-10098-HH	400	RPE-100	A-175-2	34.44

UL and UL<sub>C</sub> Listed – Guide SMGT-File No. SA-1756A & B. C-480 through C-1920 Series shells have a 650 psig rating for R-410A. C-30000 and C40000 shells have a 500 psig rating. \*Optional Secondary Filter must be purchased separately. O-rings (p/n 621-025) are supplied with each secondary filter, but can be purchased separately. The secondary filter cannot be used if the shell is installed in the suction line.

**Type numbers with G suffix** indicate that unit is supplied with 1/4" female pipe connection in the end plate and pipe plug. For liquid line service and angle charging valve for system charging purposes can be installed in place of the pipe plug. Angle charging and Schrader type access valves are available from your Sporlan Wholesaler.

**Type numbers with P suffix** indicates female threaded pipe connections.

**Note:** Do not use RPE-48-BD and RPE-100 filter elements in ammonia systems.

For complete information see your Sporlan Wholesaler, our website at [www.sporlan.com](http://www.sporlan.com), or write Sporlan and request Bulletin 40-10.

# Catch-All THE PERFECT FILTER-DRIER

22, 134a, 404A,  
407C, 410A, 507

## Liquid Line Ratings And Selection Recommendations

TYPE	③ SURFACE FILTERING AREA Square Inches	② RATINGS AT ARI STANDARD CONDITIONS										SELECTION RECOMMENDATIONS (Tons)																										
		WATER CAPACITY – DROPS										① REFRIGERANT FLOW CAPACITY Tons at 1 psi ΔP					REFRIGERATION			AIR CONDITIONING																		
		R-22 60 PPM		R-134a 50 PPM		R-404A & 507 50 PPM		R-507C 50 PPM		R-410A 50 PPM							COMMERCIAL & LOW TEMPERATURE EQUIPMENT			FIELD REPLACEMENT or FIELD BUILT UP SYSTEMS																		
		75°F	125°F	75°F	125°F	75°F	125°F	75°F	125°F	75°F	125°F	22	134a	404A & 507	407C	410A	12 & 134a	22	404A, 502 & 507	12 & 134a	22, 407C & 410A																	
<b>SEALED TYPE</b>																																						
C-032	9	61	50	67	48	71	58	52	17	27	20	1.5	1.3	1.0	1.3	1.4	1/4	1/4	1/4	1/2	1/2																	
C-032-CAP																																						
C-032-F																																						
C-032-FM																																						
C-033																												3.5	3.2	2.3	3.2	3.4						
C-033-S												3.8	3.5	2.6	3.5	3.7																						
C-052	15	146	119	158	114	169	138	123	40	63	48	2.1	1.9	1.4	1.9	2.0	1/3	1/3	1/3	3/4 thru 1	3/4 thru 2																	
C-052-S																																						
C-052-F																																						
C-052-FM																																						
C-0525-S																												3.4	3.1	2.3	3.1	3.3						
C-053												4.1	3.8	2.7	3.8	4.0																						
C-053-S												4.7	4.3	3.1	4.3	4.5																						
C-082	21	240	196	261	188	279	227	202	65	104	78	2.1	1.9	1.4	1.9	2.0	1/2 thru 1-1/2	1/2 thru 1-1/2	1/2 thru 1	3/4 thru 2	1 thru 2																	
C-082-S																																						
C-0825-S																												3.7	3.3	2.4	3.3	3.5						
C-083																												4.5	4.2	3.0	4.2	4.4						
C-083-S																												5.2	4.7	3.4	4.7	5.0						
C-084												8.7	7.9	5.9	8.0	8.5																						
C-084-S												9.6	8.8	6.4	8.8	9.4																						
C-162	33	346	297	396	285	424	345	307	100	158	119	2.1	1.9	1.4	1.9	2.0	1 thru 2	1-1/2 thru 3	3/4 thru 2	1 thru 5	1-1/2 thru 5																	
C-162-S																																						
C-1625-S																												3.7	3.3	2.4	3.3	3.5						
C-163																												4.5	4.2	3.0	4.2	4.4						
C-163-S																												5.2	4.7	3.4	4.7	5.0						
C-164												10.1	9.3	6.8	9.3	9.8																						
C-164-S												11.0	10.1	7.3	10.1	10.7																						
C-165												13.8	12.6	9.2	12.7	13.4																						
C-165-S												15.9	14.5	10.6	14.6	15.5																						
C-303	53	696	567	756	545	809	658	586	189	302	227	4.6	4.2	3.0	4.2	4.4	3 thru 5	3 thru 5	2 thru 5	3 thru 7-1/2	4 thru 10																	
C-303-S																																						
C-304																												10.1	9.3	6.8	9.3	9.8						
C-304-S																												11.0	10.1	7.3	10.1	10.7						
C-305																												14.9	13.6	9.9	13.7	14.5						
C-305-S												16.9	15.5	11.3	15.5	16.4																						
C-307-S												21.6	19.8	14.4	19.9	21.0																						
C-414	67	936	713	1017	733	1088	885	788	254	407	305	11.5	10.5	7.6	10.5	11.1	5 thru 10	5 thru 12	5 thru 10	5 thru 12	7-1/2 thru 15																	
C-414-S																																						
C-415																												12.4	11.4	8.3	11.4	12.1						
C-415-S																												15.8	14.5	10.6	14.6	15.4						
C-417-S																												17.5	16.1	11.8	16.2	17.1						
C-419-S												22.1	20.3	14.8	20.4	21.5																						
C-607-S												24.3	22.3	16.3	22.4	23.7																						
C-609-S	106	1392	1134	1512	1090	1618	1316	1172	378	604	454	29.1	26.6	19.5	26.8	28.4	15	15	10	15	20																	
												33.2	30.4	22.3	30.7	32.4																						

① Based on 86°F liquid line temperature and a refrigerant flow of 3.1 pounds per minute per ton of Refrigerant 134a; 2.9 pounds per minute per ton of Refrigerant 22; 3.9 pounds per minute per ton for Refrigerant 404A; 2.9 pounds per minute per ton for Refrigerant 407C; 2.8 pounds per minute per ton for Refrigerant 410A and 4.1 pounds per minute per ton for Refrigerant 507. Ratings in accordance to ARI Standard 710.  
 ② 20 drops = 1 gram = 1 cc.  
 ③ The filtration area is equal to the core surface area plus the large internal surface available for depth filtration.

**Notes:** R-12 water capacity values are approximately 15 percent greater than R-134a. R-502 water capacities are similar to R-404A and R-507.

The variation in flow ratings of filter-driers having the same size core and shell is caused by the difference in connection sizes used.

For complete capacity and selection information see your Sporlan Wholesaler, our website at [www.sporlan.com](http://www.sporlan.com), or write Sporlan and request Bulletin 40-10.



22, 134a, 404A,  
407C, 410A, 507

### Liquid Line Ratings And Selection Recommendations

TYPE	③ SURFACE FILTERING AREA Square Inches	② RATINGS AT ARI STANDARD CONDITIONS										SELECTION RECOMMENDATIONS (Tons)								
		WATER CAPACITY – DROPS										① REFRIGERANT FLOW CAPACITY Tons at 1 psi ΔP			REFRIGERATION			AIR CONDITIONING		
		R-22 60 PPM		R-134a 50 PPM		R-404A & 507 50 PPM		COMMERCIAL & LOW TEMPERATURE EQUIPMENT			FIELD REPLACEMENT or FIELD BUILT UP SYSTEMS									
		75°F	125°F	75°F	125°F	75°F	125°F	22	134a	404A & 507	12 & 134a	22	404A, 502 & 507	12 & 134a	22					
<b>REPLACEABLE CORE TYPE WITH STANDARD CORES (See page 44)</b>																				
C-485-G	64	347	288	583	473	408	309	14.6	13.4	9.8	7-1/2	10	7-1/2	7-1/2	10					
C-487-G								23.9	21.9	16.0	12	15	10	12	15					
C-489-G								43.2	39.5	28.9	15	10	15	20						
C-967-G	128	694	576	1166	946	816	618	39.2	35.9	26.2	20	25	15	20	25					
C-969-G								48.7	44.5	32.6	25	35	25	25	35					
C-1449-G	192	1041	864	1749	1419	1224	927	59.2	54.1	39.7	30	40	30	30	40					
C-14411-G								67.0	61.3	44.8	40	50	35	40	50					
C-19211-G								84.5	77.3	56.3	50	70	50	50	70					
C-19213-G	256	1388	1152	2332	1892	1632	1236	99.0	90.6	66.2	60	80	55	60	80					
C-19217-G								104	95.1	69.5	65	85	60	65	85					
C-30013-G	294	2670	1878	3912	3009	2631	1992	112	102	74.5	75	100	70	75	100					
C-40017-G	392	3560	2504	5216	4012	3508	2652	134	132	96.8	110	130	100	110	130					

TYPE	③ SURFACE FILTERING AREA Square Inches	② RATINGS AT ARI STANDARD CONDITIONS										SELECTION RECOMMENDATIONS (Tons)										
		WATER CAPACITY – DROPS										① REFRIGERANT FLOW CAPACITY Tons at 1 psi ΔP					REFRIGERATION			AIR CONDITIONING		
		R-22 60 PPM		R-134a 50 PPM		R-404A & 507 50 PPM		R-407C 50 PPM		R-410A 50 PPM							COMMERCIAL & LOW TEMPERATURE EQUIPMENT			FIELD REPLACEMENT or FIELD BUILT UP SYSTEMS		
		75°F	125°F	75°F	125°F	75°F	125°F	75°F	125°F	75°F	125°F	22	134a	404A & 507	407C	410A	12 & 134a	22	404A, 502 & 507	12 & 134a	22 & 407C	410A
<b>REPLACEABLE CORE TYPE WITH HIGH WATER CAPACITY CORES (See page 44)</b>																						
C-R424-G	67	902	735	981	706	1049	853	760	245	—	—	11.4	10.4	7.6	10.5	—	3	5	5	5	5	—
C-R425-G												13.7	12.5	9.1	12.5	—	5	7-1/2	5	7-1/2	10	—
C-R427-G												18.5	16.9	12.4	17.0	—	—	—	—	—	—	—
C-485-G	64	1109	904	1201	868	1290	1049	934	301	481	361	14.6	13.4	9.8	13.5	14.3	7-1/2	10	7-1/2	7-1/2	10	10
C-487-G												23.9	21.9	16.0	22.0	23.3	12	15	10	12	15	15
C-489-G												43.2	39.5	28.9	39.8	42.2	15	20	15	20	20	
C-967-G	128	2218	1808	2402	1736	2580	2098	1868	602	962	722	39.2	35.9	26.2	36.1	38.3	20	25	15	20	25	25
C-969-G												48.7	44.5	32.6	44.8	47.5	25	35	25	25	35	35
C-1449-G	192	3327	2712	3603	2604	3870	3147	2802	903	1443	1083	59.2	54.1	39.7	54.6	57.9	30	40	30	30	40	40
C-14411-G												67.0	61.3	44.8	61.7	65.4	40	50	35	40	50	50
C-19211-G												84.5	77.3	56.3	77.7	82.4	50	70	50	50	70	70
C-19213-G	256	4436	3616	4804	3472	5160	4196	3736	1204	1924	1444	99.0	90.6	66.2	91.1	96.6	60	80	55	60	80	80
C-19217-G												104	95.1	69.5	95.7	101	65	85	60	65	85	85
C-30013-G	294	6786	5532	7375	5310	7890	6417	5716	1844	—	—	112	102	74.5	103	—	75	100	70	75	100	—
C-40017-G	392	9048	7376	9833	7080	10520	8556	7621	2458	—	—	134	132	96.8	133	—	110	130	100	110	130	—

① Based on 86°F liquid line temperature and a refrigerant flow of 3.1 pounds per minute per ton of Refrigerant 134a; 2.9 pounds per minute per ton of Refrigerant 22; 3.9 pounds per minute per ton of Refrigerant 404A; 2.9 pounds per minute per ton of Refrigerant 407C; 2.8 pounds per minute per ton of Refrigerant 410A and 4.1 pounds per minute per ton for Refrigerant 507. Ratings in accordance to ARI Standard 710.

② 20 drops = 1 gram = 1 cc.

③ The filtration area is equal to the core surface area plus the large internal surface available for depth filtration.

Notes: R-12 water capacity values are approximately 15 percent greater than R-134a. R-502 water capacities are similar to R-404A and R-507.

The variation in flow ratings of filter-driers having the same size core and shell is caused by the difference in connection sizes used.

For complete capacity and selection information see your Sporlan Wholesaler, our website at [www.sporlan.com](http://www.sporlan.com), or write Sporlan and request Bulletin 40-10.

# THE PERFECT FILTER-DRIER

22, 134a, 404A,  
407C, 410A, 507

## Suction Line Filter-Drier Ratings

for New Systems and Clean-up after Burnout

### Selection Instructions

Except for the values in bold (R-22/R-407C/R-410A at 40°F; 8 psi pressure drop), the flow capacities are rated at the maximum recommended pressure drop for **permanent** installation.

To ensure the suction line filter-drier has ample contaminant removal ability, selection must be based on flow capacity and the amount of desiccant required for system clean-up. The suction line filter-drier must be large enough to adequately remove acid, moisture and solid contaminants without causing nuisance plug-ups. Sizing is especially important for sealed type

suction line filter-driers since they should be sized to clean a small system with one service call.

To reduce the pressure drop through replaceable core shells, substitute cores with filter elements (see page 44) after the system has been cleaned up. The 6171-5 screen should be discarded when cores are replaced with RPE-48-BD elements in RSF shells.

For complete description of the suggested system clean-up procedure, request Bulletin 40-10.

### Suction Line Flow Capacity (Tons) – Sealed Type

REFRIGERANT		22					134a			404A				407C	410A
EVAPORATOR TEMPERATURE		40°F	20°F	0°F	-20°F	-40°F	40°F	20°F	0°F	20°F	0°F	-20°F	-40°F	40°F	40°F
PRESSURE DROP (psi)		3.0	2.0	1.5	1.0	0.5	2.0	1.5	1.0	2.0	1.5	1.0	0.5	3.0	3.0
SEALED TYPE	C-083-S-T-HH	2.1	1.3	0.9	0.5	0.2	1.3	0.9	0.5	1.2	0.8	0.5	0.2	2.0	2.7
	C-084-S-T-HH	2.1	1.3	0.9	0.5	0.3	1.4	0.9	0.6	1.3	0.8	0.5	0.3	2.1	2.7
	C-144-S-T-HH	2.1	1.3	0.9	0.4	0.2	1.3	0.8	0.5	0.9	0.6	0.3	0.2	2.1	2.7
	C-145-S-T-HH	3.4	2.2	1.4	0.8	0.4	2.1	1.3	0.8	1.6	1.0	0.6	0.3	3.4	4.6
	C-146-S-T-HH	4.8	3.0	2.0	1.2	0.6	2.9	1.8	1.1	2.1	1.4	0.9	0.4	4.8	6.2
	C-147-S-T-HH	5.3	3.3	2.2	1.3	0.7	3.2	2.1	1.3	2.4	1.6	0.9	0.5	5.3	6.8
	C-149-S-T-HH	7.0	4.4	2.9	1.7	0.9	4.2	2.7	1.6	3.2	2.1	1.2	0.6	7.0	9.0
	C-164-S-T-HH	2.7	1.7	1.1	0.7	0.3	1.7	1.1	0.7	1.6	1.0	0.6	0.3	2.7	3.6
	C-165-S-T-HH	3.2	2.0	1.3	0.8	0.4	2.0	1.3	0.8	1.9	1.2	0.7	0.4	3.2	4.2
	C-166-S-T-HH	4.0	2.5	1.6	1.0	0.5	2.6	1.7	1.0	2.4	1.6	0.9	0.5	3.9	5.2
	C-167-S-T-HH	4.5	2.8	1.8	1.1	0.5	2.8	1.8	1.1	2.7	1.7	1.0	0.5	4.4	5.9
	C-305-S-T-HH	3.4	2.1	1.4	0.8	0.4	2.2	1.4	0.8	2.0	1.3	0.8	0.4	3.4	4.4
	C-306-S-T-HH	4.4	2.8	1.8	1.1	0.5	2.8	1.8	1.1	2.7	1.7	1.0	0.5	4.4	5.8
	C-307-S-T-HH	5.3	3.3	2.2	1.3	0.6	3.4	2.2	1.3	3.2	2.0	1.2	0.6	5.3	7.0
	C-309-S-T-HH	5.9	3.7	2.4	1.5	0.7	3.8	2.4	1.5	3.6	2.3	1.4	0.7	5.8	7.7
	C-417-S-T-HH	6.0	3.8	2.5	1.5	0.7	3.8	2.5	1.5	3.6	2.3	1.4	0.7	6.0	7.9
	C-419-S-T-HH	6.2	3.9	2.5	1.5	0.8	4.0	2.6	1.6	3.7	2.4	1.5	0.7	6.1	8.0
	C-437-S-T-HH	8.0	5.0	3.3	2.0	1.0	5.1	3.3	2.1	4.8	3.1	1.9	0.9	7.9	10.4
	C-439-S-T-HH	10.0	6.3	4.1	2.5	1.2	6.4	4.2	2.5	6.0	3.9	2.4	1.2	9.9	13.1
	C-4311-S-T-HH	11.1	6.9	4.6	2.7	1.4	7.1	4.6	2.8	6.7	4.3	2.6	1.3	10.9	14.4
C-4313-S-T-HH	12.2	7.6	5.0	3.0	1.5	7.8	5.1	3.1	7.3	4.7	2.9	1.4	12.0	15.9	
C-607-S-T-HH	6.7	4.2	2.7	1.6	0.8	4.2	2.7	1.7	4.0	2.6	1.6	0.8	6.6	8.7	
C-609-S-T-HH	7.5	4.7	3.1	1.8	0.9	4.8	3.1	1.9	4.5	2.9	1.8	0.9	7.4	9.8	

### Suction Line Flow Capacity (Tons) – Shells With Replaceable Cores

REFRIGERANT		22					134a			404A & 507				407C	410A			
EVAPORATOR TEMPERATURE		40°F	20°F	0°F	-20°F	-40°F	40°F	20°F	0°F	20°F	0°F	-20°F	-40°F	40°F	40°F			
PRESSURE DROP (psi)		3.0	8.0*	2.0	1.5	1.0	0.5	2.0	1.5	1.0	2.0	1.5	1.0	0.5	3.0	8.0*	3.0	8.0*
REPLACEABLE CORE TYPE	RSF-487-T	10.1	17.5	6.3	4.1	2.5	1.2	6.4	4.2	2.5	6.1	4.0	2.3	1.2	10.0	17.3	12.6	21.9
	RSF-489-T	12.2	21.1	7.6	5.0	3.0	1.5	7.8	5.1	3.1	7.3	4.8	2.8	1.4	12.0	20.7	15.3	26.4
	RSF-4811-T	14.8	25.6	9.3	6.1	3.6	1.8	9.4	6.2	3.7	8.9	5.8	3.4	1.7	14.6	25.3	18.5	32.0
	RSF-4813-T	15.9	27.5	10.0	6.5	3.9	1.9	10.1	6.7	4.0	9.6	6.2	3.6	1.8	15.7	27.2	19.9	34.4
	RSF-4817-T	17.2	29.8	10.8	7.1	4.2	2.1	11.0	7.2	4.4	10.4	6.8	3.9	2.0	17.0	29.4	21.5	37.3
	RSF-4821-T	18.6	32.2	11.6	7.6	4.6	2.3	11.9	7.8	4.7	11.2	7.3	4.3	2.2	18.4	31.6	23.3	40.3
	RSF-9611-T	23.8	39.0	15.9	11.1	7.1	3.9	14.5	10.5	6.7	14.4	9.8	6.2	3.3	22.9	37.6	29.8	48.8
	RSF-9613-T	29.7	49.0	19.8	13.7	8.7	4.7	15.2	13.0	8.1	17.9	12.2	7.6	4.0	28.6	47.2	37.1	61.3
	RSF-9617-T	29.7	49.0	19.8	13.7	8.7	4.7	16.1	13.0	8.1	17.9	12.2	7.6	4.0	28.6	47.2	37.1	61.3
	RSF-9621-T	29.7	50.7	19.8	13.7	8.7	4.7	18.7	13.0	8.1	17.9	12.2	7.6	4.0	28.9	49.8	37.1	61.3
	RSF-9625-T	30.0	51.9	20.0	13.7	8.7	4.7	19.2	13.0	8.1	17.9	12.2	7.6	4.0	29.7	51.0	37.5	63.4
	C-30013-G	26.6	46.0	16.7	10.9	6.5	3.2	16.9	11.0	6.7	16.0	10.3	6.2	3.1	26.3	42.8	33.3	64.9
	C-30017-G	27.0	46.7	16.9	11.1	6.6	3.3	17.2	11.1	6.8	16.2	10.4	6.3	3.1	26.7	43.3	33.8	58.4
	C-40017-G	32.9	56.9	20.6	13.5	8.1	4.0	21.0	13.6	8.3	19.8	12.8	7.2	3.8	32.4	52.8	41.1	71.1
	C-40021-G thru C-40033-G	32.9	56.9	20.6	13.5	8.1	4.0	21.0	13.6	8.3	19.8	12.8	7.2	3.8	32.4	52.8	41.1	71.1

\*Denotes TEMPORARY INSTALLATION. Cores for system clean-up; RPE-48-BD or RPE-100 Filter Elements should be installed after clean-up. Rated in accordance with ARI Standard 730.

For a simplified "Quick Selection Guide," request Form 40-109.

# ▼ Catch-All THE PERFECT FILTER-DRIER

## Significance of the Type Number

The letters and numerals in the Catch-All® type number each have a significance. The “C” indicates Catch-All. The **FIRST TWO OR THREE DIGITS** indicate cubic inches of desiccant. The **LAST ONE OR TWO DIGITS** indicate fitting size in eighths of an inch. For sealed models, a “-S” following the last digit indicates solder fittings, and **NO LETTER** indicates a flare fitting. Replaceable core models (C-420 and larger) only have solder connections and the “-S” is omitted. Examples are: C-083 is 8 cu. in. and 3/8” flare, C-309-S is 30 cu. in. and 1-1/8” solder, C-19213-G is 192 cu. in. and 1-5/8” solder.

## Replaceable Cores and Pleated Filter Elements – Order Separately

Cores for replaceable core type filter-driers are molded of exactly the same desiccants that are used in the popular sealed filter-driers.

Cores are individually packed in **metal cans**, fully activated and hermetically sealed against moisture and dirt.

Filter Elements are dried and packed in individual sealed metal cans. This method of packaging prevents the element from picking up moisture from the atmosphere.

Detailed **instructions** are printed on each can. Each can contains a “**triple gasket**” consisting of a new end plate gasket, an end plate gasket for certain competitive filter-driers and a core gasket where desired. See the specifications on page 40 for the number of cores required for each type drier.

**RCW-42** – High Water Capacity Core – Order as separate item – Fits ONLY shell type C-R424, C-R425 and C-R427. **Designed specially for use with POE oils.** This core should be used on systems that have a ruptured water cooled condenser, or that have been exposed to the atmosphere, or for some reason have a high amount of moisture in the system.

**RC-4864** – Activated Core – Order as separate item – Fits types C-480 thru C-19200 Series shells and Replaceable Suction Filter (RSF) shells. This is the standard core suitable for most installations in the liquid or suction line applications.

**RCW-48** – High Water Capacity Core – Order as separate item – Fits types C-480 thru C-19200 Series shells and Replaceable Suction Filter (RSF) shells. **Designed specially for use with POE oils.** This core should be used on systems that have a ruptured water cooled condenser, or that have been exposed to the atmosphere, or for some reason have a high amount of moisture in the system.

## HH Style Catch-All for Wax Removal

Small amounts of wax are often a problem on **low temperature systems**. Even well engineered systems frequently contain minute quantities of wax which are sufficient to clog expansion valve screens or cause sticking of the valve. Sporlan has developed a special blend of desiccants including activated charcoal which removes small amounts of wax in the liquid line before this wax can cause trouble at the expansion valve. These Catch-All Filter-Driers have been very successful in correcting trouble jobs in the field.

Select an HH Style Catch-All Filter-Drier if wax problems occur on low temperature systems. In addition to their wax removal ability, these filter-driers will remove all of the other harmful contaminants that the standard filter-driers remove. Listed in the table are various Catch-All models that incorporate the HH style core.

Other suffix letters indicate special qualities. For example:

- “-T” indicates a pressure tap consisting of a Schrader type access valve on the inlet end of the Catch-All.
- “-HH” indicates a charcoal style core for wax removal and clean-up after a hermetic motor burnout.
- “-F” indicates a female flare outlet fitting with a male flare inlet fitting.
- “-FM” indicates a female flare inlet fitting with a male flare outlet fitting.
- “-CAP” indicates a Catch-All particularly designed for installation on capillary tube systems.



**RC-4864-HH** – Activated Charcoal Core – Order as separate item – Fits types C-480 thru C-19200 Series shells and Replaceable Suction Filter (RSF) shells. This core should be used for wax removal on low temperature systems, and for clean-up of systems that have had a hermetic motor burnout.

**RPE-48-BD** – Filter Element – Order as separate item – Fits types C-480 thru C-19200 Series shells and **Replaceable Suction Filter (RSF) shells**. This element should be used in RSF shells installed in the **suction line** to obtain the lowest possible pressure drop. In cleaning up a system after a hermetic motor burnout, cores should be used first. Then after the system is thoroughly clean, this filter element can be installed in the RSF shell.

**RC-10098** – Activated Core – Order as separate item – Fits types C-30000 and C-40000 Series shells. This core has a high water capacity and should be used on all standard liquid and suction line applications.

**RCW-100** – High Water Capacity Core – Order as separate item – Fits types C-30000 and C-40000 Series shells. **Designed specially for use with POE oils.** This core should be used on systems that have a ruptured water cooled condenser, or that have been exposed to the atmosphere, or for some reason have a high amount of moisture in the system.

**RC-10098-HH** – Activated Charcoal Core – Order as separate item – Fits types C-30000 and C-40000 Series shells. This core should be used for wax removal on low temperature systems, and for clean-up of systems that have had a hermetic motor burnout.

**RPE-100** – Filter Element – Order as separate item – Fits types C-30000 and C40000 Series shells. This filter element should be used in the suction line to obtain the lowest possible pressure drop after cores were used for system clean-up.

TYPE	CONNECTIONS Inches	TYPE	CONNECTIONS Inches
C-052-HH	1/4 SAE Flare	C-303-HH	3/8 SAE Flare
C-082-HH	1/4 SAE Flare	C-304-HH	1/2 SAE Flare
C-083-HH	3/8 SAE Flare	C-304-S-HH	1/2 ODF Solder
C-162-HH	1/4 SAE Flare	C-305-HH	5/8 SAE Flare
C-163-HH	3/8 SAE Flare	C-305-S-HH	5/8 ODF Solder
C-163-S-HH	3/8 ODF Solder	C-414-HH	1/2 SAE Flare
C-164-HH	1/2 SAE Flare	C-415-HH	5/8 SAE Flare
C-164-S-HH	1/2 ODF Solder	C-417-S-HH	7/8 ODF Solder
C-165-HH	5/8 SAE Flare	RC-4864-HH	Replaceable Core
C-165-S-HH	5/8 ODF Solder	RC-10098-HH	

For dimensions, refer to the specifications for standard filter-driers or consult Bulletin 40-10.



# REVERSIBLE HEAT PUMP FILTER-DRIERS

## Design Features

- New product line-up with enhanced flow capacities deliver system protection solutions for today's system sizes.
- Filter-drier operates in either flow direction with low pressure drop.
- Rugged metal check valve designed for maximum flow capacity.
- Sporlan dependable molded core used for maximum filtration ability. When flow reverses, dirt already collected remains in the filter-drier.
- Carefully engineered desiccant formulations for new system and system clean-up for all commercially available HCFC and HFC refrigerant/lubricant combinations.

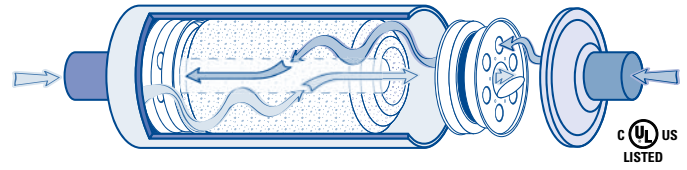

- HPC-160 and HPC-300 Series offer the largest core sizes available in the industry for these filter-drier types. A larger molded core provides superior performance, and is especially advantageous for R-410A/POE lubricant systems.
- Catch-All® shells are epoxy powder coated to prevent corrosion even in the most adverse conditions.
- Shells listed by Underwriters' Laboratories for 650 psig for R-410A systems.

## Specifications – For New Installations

TYPE NUMBER	CONNECTION SIZE Inches	SELECTION RECOMMEND. Tons	DIMENSIONS		SPECIFICATIONS											
			OVERALL LENGTH Inches	DIA. Inches	FLOW CAPACITY Tons @ 1 psi ΔP			WATER CAPACITY						LIQUID CAPACITY Ounces (wt.) @ 100°F		
					R-22	R-407C	R-410A	R-22 Drops at 60 ppm		R-407C Drops at 50 ppm		R-410A Drops at 50 ppm		R-22	R-407C	R-410A
75°F	125°F	75°F	125°F	75°F	125°F	75°F	125°F	75°F	125°F	75°F	125°F	75°F	125°F	75°F	125°F	
HPC-103	3/8 SAE Flare	1 – 5	6.75	3.0	5.0	4.6	4.9	215	176	181	60	94	70	12.2	10.7	10.6
HPC-103-S	3/8 ODF Solder		5.88		5.5	5.1	5.4									
HPC-104	1/2 SAE Flare		6.94		8.3	7.6	8.1									
HPC-104-S	1/2 ODF Solder		6.00		8.9	8.2	8.7									
HPC-105	5/8 SAE Flare		7.25		10.2	9.4	10.0									
HPC-105-S	5/8 ODF Solder		6.31		10.8	9.9	10.6									
HPC-163	3/8 SAE Flare	1 – 8	7.78	3.0	5.0	4.6	4.9	364	297	307	100	158	119	14.5	12.7	12.6
HPC-163-S	3/8 ODF Solder		6.92		5.5	5.1	5.4									
HPC-164	1/2 SAE Flare		7.95		8.3	7.6	8.1									
HPC-164-S	1/2 ODF Solder		7.07		8.9	8.2	8.7									
HPC-165	5/8 SAE Flare		8.28		10.2	9.4	10.0									
HPC-165-S	5/8 ODF Solder		7.35		10.8	9.9	10.6									
HPC-304	1/2 SAE Flare	8 – 20	11.08	3.0	8.7	8.0	8.5	696	567	586	189	302	227	19.7	17.3	17.2
HPC-304-S	1/2 ODF Solder		10.18		9.3	8.6	9.1									
HPC-305	5/8 SAE Flare		11.38		9.9	9.1	9.7									
HPC-305-3	5/8 ODF Solder		10.42		10.5	9.7	10.3									
HPC-306-S	3/4 ODF Solder		10.86		11.0	10.1	10.8									
HPC-307-S	7/8 ODF Solder		11.02		11.4	10.5	11.2									

## Specifications – For Clean-Up After Burnout

TYPE NUMBER	CONNECTION SIZE Inches	SELECTION RECOMMEND. Tons	DIMENSIONS		SPECIFICATIONS											
			OVERALL LENGTH Inches	DIA. Inches	FLOW CAPACITY Tons @ 1 psi ΔP			WATER CAPACITY						LIQUID CAPACITY Ounces (wt.) @ 100°F		
					R-22	R-407C	R-410A	R-22 Drops at 60 ppm		R-407C Drops at 50 ppm		R-410A Drops at 50 ppm		R-22	R-407C	R-410A
75°F	125°F	75°F	125°F	75°F	125°F	75°F	125°F	75°F	125°F	75°F	125°F	75°F	125°F	75°F	125°F	
HPC-163-HH	3/8 SAE Flare	1 – 8	7.78	3.0	4.8	4.4	4.7	93	81	90	88	69	100	14.5	12.7	12.6
HPC-163-S-HH	3/8 ODF Solder		6.92		5.2	4.8	5.1									
HPC-164-HH	1/2 SAE Flare		7.95		7.9	7.3	7.7									
HPC-164-S-HH	1/2 ODF Solder		7.07		8.5	7.8	8.3									
HPC-165-HH	5/8 SAE Flare		8.28		9.7	8.9	9.5									
HPC-165-S-HH	5/8 ODF Solder		7.35		10.3	9.5	10.1									
HPC-304-HH	1/2 SAE Flare	8 – 20	11.08	3.0	8.3	7.6	8.1	167	119	161	88	123	109	19.7	17.3	17.2
HPC-304-S-HH	1/2 ODF Solder		10.18		8.8	8.1	8.6									
HPC-305-HH	5/8 SAE Flare		11.38		9.4	8.6	9.2									
HPC-305-S-HH	5/8 ODF Solder		10.42		10.8	9.2	9.8									
HPC-307-S-HH	7/8 ODF Solder		11.02		10.8	9.9	10.6									

HPC-100 Series – Core volume is 10 cubic inches. Core surface filtering area is 18 sq. inches. Maximum rated pressure is 650 psig.  
 HPC-160 Series – Core volume is 14 cubic inches. Core surface filtering area is 26 sq. inches. Maximum rated pressure is 650 psig.  
 HPC-300 Series – Core volume is 30 cubic inches. Core filtering area is 53 sq. inches. Maximum rated pressure is 650 psig.  
 UL and UL<sub>C</sub> Listed – Guide-SMGT-File No. SA-1756A & B.

For complete information see your Sporlan Wholesaler, our website at [www.sporlan.com](http://www.sporlan.com), or write Sporlan and request Bulletin 40-10.

## ▼ STEEL SUCTION LINE ACCUMULATORS

### U-Tube Style Accumulators

The U-tube accumulator design is a result of extensive laboratory testing plus detailed investigation of the various accumulators currently available. It takes into account essential requirements such as safe holding volume (relative to the system's total charge), protected flow control for positive refrigerant and oil return, and minimum pressure drop across the accumulator.

Sporlan offers standard accumulator models designed for application on heat pump and refrigeration systems from 1/4 through 12 tons. Liquid refrigerant holding requirements of suction accumulator may vary by application. Because of the diversity in systems, optimum performance should be determined by the system designer. Consult Sporlan for assistance if required.

### Features and Benefits

- Solid copper connections
- U-tube design for maximum flow of refrigerant and minimum oil entrapment
- Inlet flow deflector guides refrigerant toward wall for smooth tangential flow and gradual expansion
- U-tube entrance is positioned behind the inlet flow deflector to prevent unwanted liquid refrigerant from entering and damaging compressor
- Metering orifice matched to system capacity assures optimum liquid refrigerant and oil flow back to compressor
- Protective screen and orifice assembly on U-tube protects against contaminants affecting metering function
- Fittings and U-tube are matched to accumulator holding capacity and total system charge for minimum pressure drop and maximum refrigerant flow
- U.L. listed for 355 psig maximum working pressure. File No. SA5172
- Powder coating surpasses 500 hour ASTM salt spray
- Integral 430°F fuse plugs (U.L. File No. SA5441)



Model PA6

### Dimensions and Flow Data

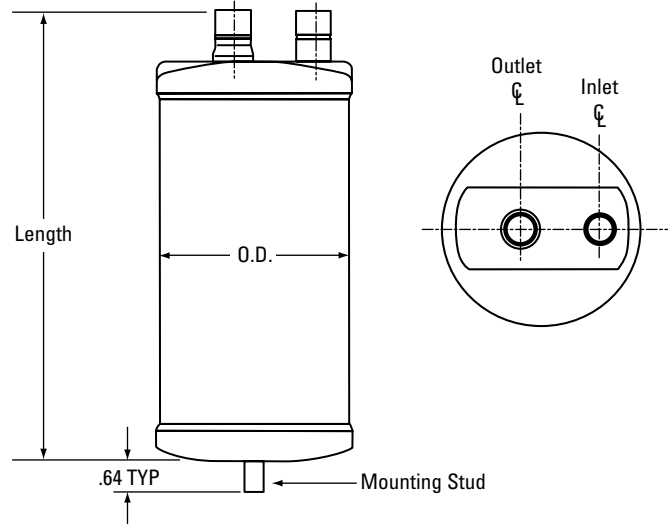

# ▼ STEEL SUCTION LINE ACCUMULATORS

## Dimensions and Flow Data

MODEL NUMBER	CONN. Inches (ODF)	DIMENSIONS Inches		CAPACITY Ounces* (wt.)	EVAP. TEMP. °F	RECOMMENDED CAPACITY IN TONS OF REFRIGERATION													
		LENGTH	O.D.			22 & 404A		134a		401A		402A		407C		410A		502 & 507	
						Tons @ 1 psi	Min. Tons	Tons @ 1 psi	Min. Tons	Tons @ 1 psi	Min. Tons	Tons @ 1 psi	Min. Tons	Tons @ 1 psi	Min. Tons	Tons @ 1 psi	Min. Tons	Tons @ 1 psi	Min. Tons
PA3060-10-4 PA3060-10-5	1/2 5/8	10.35 10.35	3 3	35 35	40	2.00	0.35	1.67	0.30	1.42	0.25	1.97	1.01	1.97	0.46	1.93	1.44	1.48	0.27
					0	1.54	0.25	0.98	0.16	1.06	0.18	1.53	0.41	1.53	0.18	1.50	0.65	1.10	0.20
					-20	1.33	0.21	0.69	0.11	0.90	0.15	1.32	0.25	1.32	0.11	1.30	0.42	0.93	0.16
PA3060-15-5	5/8	15.05	3	55	40	2.10	0.35	1.75	0.30	1.49	0.25	2.07	1.01	2.07	0.46	2.02	1.44	1.55	0.27
					0	1.62	0.25	1.03	0.16	1.11	0.18	1.61	0.41	1.60	0.18	1.57	0.65	1.16	0.20
					-20	1.40	0.21	0.73	0.11	0.95	0.15	1.39	0.25	1.39	0.11	1.36	0.42	0.98	0.16
PA3060-15-6	3/4	15.05	3	54	40	2.30	0.35	1.92	0.30	1.63	0.25	2.27	1.01	2.27	0.46	2.22	1.44	1.70	0.27
					0	1.77	0.25	1.12	0.16	1.22	0.18	1.76	0.41	1.75	0.18	1.72	0.65	1.27	0.20
					-20	1.53	0.21	0.80	0.11	1.04	0.15	1.52	0.25	1.52	0.11	1.49	0.42	1.07	0.16
PA4065-9-5C	5/8	9.62	4	60	40	2.96	0.35	2.47	0.30	2.10	0.25	2.92	1.01	2.92	0.46	2.85	1.44	2.19	0.27
					0	2.28	0.25	1.44	0.16	1.57	0.18	2.27	0.41	2.26	0.18	2.21	0.65	1.63	0.20
					-20	1.98	0.21	1.03	0.11	1.34	0.15	1.97	0.25	1.96	0.11	1.93	0.42	1.39	0.16
PA4065-9-6C	3/4	9.62	4	58	40	3.00	0.35	2.53	0.30	2.10	0.25	2.96	1.01	2.96	0.46	2.89	1.44	2.20	0.28
					0	2.30	0.25	1.48	0.16	1.60	0.18	2.29	0.41	2.28	0.18	2.23	0.65	1.70	0.20
					-20	2.00	0.21	1.05	0.11	1.40	0.15	1.99	0.25	1.98	0.11	1.95	0.42	1.40	0.16
PA5083-9-6C	3/4	9.62	5	89	40	3.82	0.57	3.19	0.49	2.71	0.41	3.76	1.51	3.77	0.69	3.68	2.16	2.82	0.46
					0	2.95	0.41	1.86	0.27	2.03	0.30	2.94	0.61	2.92	0.27	2.86	0.98	2.10	0.33
					-20	2.55	0.35	1.32	0.18	1.73	0.24	2.53	0.37	2.53	0.16	2.48	0.63	1.79	0.27
PA5083-9-7C	7/8	9.63	5	86	40	3.90	0.57	3.21	0.49	2.70	0.41	3.84	1.51	3.85	0.69	3.76	2.16	2.80	0.46
					0	3.00	0.41	1.88	0.27	2.00	0.30	2.98	0.61	2.97	0.27	2.91	0.98	2.10	0.33
					-20	2.60	0.35	1.33	0.18	1.70	0.24	2.58	0.37	2.58	0.16	2.53	0.63	1.80	0.27
PA5083-12-7C	7/8	12.88	5	125	40	5.41	0.88	4.51	0.75	3.83	0.64	5.33	2.12	5.34	0.96	5.21	3.03	4.00	0.70
					0	4.17	0.64	2.64	0.42	2.87	0.45	4.15	0.86	4.13	0.38	4.05	1.37	2.98	0.51
					-20	3.61	0.54	1.87	0.28	2.45	0.37	3.59	0.52	3.58	0.22	3.52	0.88	2.53	0.41
PA5083-11-7C	7/8	11.33	5	108	40	4.38	0.57	3.21	0.43	3.10	0.41	4.32	1.51	4.32	0.69	4.22	2.16	3.23	0.46
					0	3.37	0.41	1.88	0.24	2.32	0.30	3.35	0.61	3.34	0.27	3.27	0.98	2.41	0.33
					-20	2.92	0.35	1.33	0.16	1.98	0.24	2.90	0.57	2.89	0.16	2.84	0.63	2.04	0.27
PA5083-11-6C	3/4	11.33	5	111	40	3.85	0.57	3.21	0.49	2.72	0.41	3.79	1.51	3.80	0.69	3.71	2.16	2.84	0.46
					0	2.97	0.41	1.88	0.27	2.04	0.30	2.96	0.61	2.94	0.27	2.88	0.98	2.12	0.33
					-20	2.56	0.35	1.33	0.18	1.74	0.24	2.54	0.57	2.54	0.16	2.49	0.63	1.80	0.27
PA5083-15-7C	7/8	15.34	5	156	40	6.20	0.88	5.17	0.75	4.39	0.64	6.11	2.12	6.12	0.96	5.97	3.03	4.58	0.70
					0	4.78	0.64	3.03	0.42	3.29	0.45	4.76	0.86	4.73	0.38	4.64	1.37	3.41	0.51
					-20	4.13	0.54	2.15	0.28	2.80	0.37	4.10	0.52	4.09	0.22	4.02	0.88	2.90	0.41
PA5083-17-7C	7/8	17.25	5	179	40	6.20	0.88	5.17	0.75	4.39	0.64	6.11	2.12	6.12	0.96	5.97	3.03	4.58	0.70
					0	4.78	0.64	3.03	0.42	3.27	0.45	4.76	0.86	4.73	0.38	4.64	1.37	3.41	0.51
					-20	4.13	0.54	2.15	0.28	2.80	0.37	4.10	0.52	4.09	0.22	4.02	0.88	2.90	0.41
PA6125-15-9C	1-1/8	15.00	6	211	40	9.00	3.00	8.83	1.97	6.10	1.90	8.87	3.45	8.88	1.57	8.67	4.93	7.30	3.00
					0	5.60	2.00	5.62	0.82	3.70	1.20	5.57	1.40	5.55	0.62	5.44	2.23	4.50	2.00
					-20	4.30	0.80	4.31	0.50	2.80	0.05	4.27	0.85	4.26	0.36	4.19	1.43	3.40	0.80
PA6125-15-11C	1-3/8	15.25	6	214	40	12.00	3.00	12.05	1.97	6.20	1.90	11.82	3.45	11.85	1.57	11.56	4.93	9.80	3.00
					0	7.50	2.00	7.52	0.82	5.00	1.20	7.46	1.40	7.43	0.62	7.28	2.23	6.00	2.00
					-20	5.80	0.80	5.82	0.50	3.60	0.05	5.76	0.85	5.75	0.36	5.65	1.43	4.60	0.80
PA6125-18-9C	1-1/8	18.00	6	264	40	8.80	3.00	8.84	1.97	6.00	1.90	8.67	3.45	8.69	1.57	8.48	4.93	7.20	3.00
					0	5.50	2.00	5.52	0.82	3.70	1.20	5.47	1.40	5.45	0.62	5.34	2.23	4.40	2.00
					-20	4.30	0.80	4.31	0.50	2.80	0.05	4.27	0.85	4.26	0.36	4.19	1.43	3.40	0.80
PA6125-18-11C	1-3/8	18.00	6	267	40	11.00	3.00	11.05	1.97	7.50	1.90	10.84	3.45	10.86	1.57	10.59	4.93	9.10	3.00
					0	7.00	2.00	7.02	0.82	4.60	1.20	6.96	1.40	6.93	0.62	6.80	2.23	5.50	2.00
					-20	5.40	0.80	5.42	0.50	3.50	0.05	5.37	0.85	5.35	0.36	5.26	1.43	4.20	0.80
PA6125-20-11C	1-3/8	20.25	6	302	40	11.00	3.00	11.05	1.97	7.50	1.90	10.84	3.45	10.86	1.57	10.59	4.93	9.10	3.00
					0	7.00	2.00	7.02	0.82	4.60	1.20	6.96	1.40	6.93	0.62	6.80	2.23	5.50	2.00
					-20	5.40	0.80	5.42	0.50	3.50	0.05	5.37	0.85	5.35	0.36	5.26	1.43	4.20	0.80

\*Holding capacity of R-22 at 40°F. Divide by 0.7 to obtain recommended maximum system charge on fixed orifice systems. Consult Sporlan for availability.

For complete information see your Sporlan Wholesaler, our website at [www.sporlan.com](http://www.sporlan.com), or write Sporlan and request Bulletin 40-10-7.

## ▼ STEEL RECEIVERS

### Features and Benefits

- Designed for refrigerant storage during normal operation and system pump down
- Allows the system to adjust to varying system conditions and loads
- Available in 4", 5" and 6" diameters (2-1/2" and 3" diameter vertical and horizontal receiver models available) – consult Sporlan
- Suitable for R-410A with 650 psig M.R.P.
- Integral 430°F fuse plug
- Available options: sight glasses, moisture indicators, float balls, valves, mounting brackets, belly bands, relief valve ports
- Valve is shipped unassembled
- PTFE gasket seal for valve



Model PR6

- UL file number SA5195 and CSA file number LR46423
- Powder coating surpasses 500 hour ASTM salt spray

MODEL NUMBER	DIAMETER Inches	INLET FITTING	OUTLET FITTING	OVERALL LENGTH Inches	HOLDING CAPACITY
PR4095-10-2	4	1/4 SAE Flare	1/4 SAE Flare	10	4 lbs.
PR4095-10-2C		1/4 ODF Solder	1/4 ODF Solder		
PR5109-10-2	5	1/4 SAE Flare	1/4 SAE Flare	10	6 lbs.
PR5109-10-2C		1/4 ODF Solder	1/4 ODF Solder		
PR5109-10-3	5	3/8 SAE Flare	3/8 SAE Flare	10	6 lbs.
PR5109-10-3C		3/8 ODF Solder	3/8 ODF Solder		
PR6125-12-3	6	3/8 SAE Flare	3/8 SAE Flare	12	10 lbs.
PR6125-12-3C		3/8 ODF Solder	3/8 ODF Solder		
PR6125-18-4	6	1/2 SAE Flare	1/2 SAE Flare	18	16 lbs.
PR6125-18-4C		1/2 ODF Solder	1/2 ODF Solder		

Holding capacity calculated at 90% system charge at 90°F for R-134a, R-22, R-407C, and R-410A. For R-404A and R-507 multiply by 0.9. Steel Receivers have a 650 psi M.R.P. for R-410A.

For complete information see your Sporlan Wholesaler, our website at [www.sporlan.com](http://www.sporlan.com), or write Sporlan and request Bulletin 40-10-6.

# EBV BALL VALVE SERIES

## EBV Series (Welded) EBVT Series (Welded with Access Fitting)



- Robotically welded body joint. 100% factory tested to ensure positive, leak-free performance. Forged brass body construction with extended copper fittings and optional access fittings.
- Full size ports for unrestricted flow on most sizes (3/8" through 3-1/8")
- Dual Teflon seals surround the polished, brass ball with a secondary seal to prevent leakage due to foreign material. Dual Teflon stem seals with internal packing nut for the primary seal; no synthetic "O" rings.
- Fully open to fully closed with a 1/4 turn. Positive movement ensured with internal, forged mechanical stops. No need to remove the seal cap to open or close the valve.
- Ball internal relief port design ensures positive shut-off in either flow direction...even during system evacuation.

- All EBV(T) ball valves are non-directional and may be installed in any position.
- Full refrigeration service temperature range: -40°F to +325°F (-40°C to +149°C).
- Design working pressure: 700 psig.
- U.L. and C-U.L. Listed File No. 5460.
- The new EBV(T) ball valves are suitable for use with R-11, R-12, R-22, R-123, R-125, R-134a, R-236Fa, R-402A, R-402B, R-404A, R-407C, R-410A, R-500, R-502, R-507 and RS-44.

VALVE TYPE	VALVE TYPE with ACCESS FITTING	CONNECTION ODF	OVERALL LENGTH Inches	SOCKET DEPTH Inches	BALL PORT Diameter	MAXIMUM Width	CV
EBV-1020	—	1/4	6.50	0.31	0.50	1.38	—
EBV-1030	EBVT-1030	3/8	6.50	0.31	0.50	1.38	3.60
EBV-1040	EBVT-1040	1/2	6.50	0.38	0.50	1.38	7.40
EBV-1050	EBVT-1050	5/8	6.50	0.50	0.50	1.38	14.60
EBV-1060	—	3/4	6.56	0.63	0.75	1.88	22.30
EBV-1070	EBVT-1070	7/8	6.56	0.75	0.75	1.88	30.00
EBV-1090	EBVT-1090	1-1/8	7.69	0.94	1.00	2.31	62.00
EBV-1110	EBVT-1110	1-3/8	8.88	1.00	1.50	3.19	110.00
EBV-1130	EBVT-1130	1-5/8	9.13	1.09	1.50	3.19	135.00
EBV-1170	EBVT-1170	2-1/8	9.88	1.34	2.01	4.06	270.00
EBV-2210*	—	2-5/8	12.88	1.44	2.01	4.06	250.00
EBV-2250*	—	3-1/8	13.75	1.63	2.01	4.06	240.00
EBV-1210	EBVT-1210	2-5/8	12.92	1.50	2.44	4.65	340.00
EBV-1250	EBVT-1250	3-1/8	16.31	1.69	2.91	5.63	480.00
EBV-2290*	—	3-5/8	16.03	1.94	2.91	5.63	455.00
EBV-2330*	—	4-1/8	16.03	1.94	2.91	5.63	430.00

\* Reduced port valves are not "in stock". Please consult Sporlan for minimum quantity requirement and lead times

## Nomenclature

EXAMPLE: EBVT-1030

EBV	T	-	1	03	0
Valve Type	Access Fitting (Optional)		Series: 1 = Full Port 2 = Reduced port	Fitting Size: (In eighths of an inch) ie: 03 = 3/8"	Fitting Configuration: 0 = ODF x ODF

For complete information see your Sporlan Wholesaler, our website at [www.sporlan.com](http://www.sporlan.com), or write Sporlan and request Form 50-172.



# MOISTURE and LIQUID INDICATOR

## 8 Outstanding Benefits

- One Indicator for Refrigerants 12, 134a, 22, 404A, 407C, 410A, 502 and 507.** The **See•All Moisture and Liquid Indicator** provides a true moisture indication for Refrigerants 12, 134a, 22, 404A, 407C, 410A, 502 and 507. The **See•All®** is also suitable for Refrigerants 401A & B, 402 A & B, 408A and 409A. The dark green indicates dry and a bright yellow indicates wet. The one indicator avoids the confusion found in models with two elements. You **cannot** pick the wrong element when checking the moisture content of the system.
- Reliable and Accurately calibrated color change points.** The **See•All Moisture and Liquid Indicator** is accurately calibrated in parts per million of moisture for each refrigerant. All moisture indicators change color on the basis of relative saturation of the refrigerant. Therefore, liquid line temperature must be considered if an accurate calibration is to be obtained. For easy comparison, a color chart is part of the label.
- Color Changes are easily distinguished and reversible.** The indicator's color differs so widely between WET and DRY conditions that there is no possibility of confusion between the two. Colors will reverse as often as moisture concentration in the system changes.
- Large full view sight glass.** The **See•All Moisture and Liquid Indicator** has an extra large crystal clear sight glass for viewing the refrigerant. Bubbles indicate a shortage of refrigerants or a restriction in the liquid line.
- Indicator protected from discoloration and dirt.** The indicator is protected by a filter pad and screen. This prevents washing of the indicator by the refrigerant and protects it from system contamination and turbulence.
- Replaceable indicator element.** The color indicator paper can be changed on the new fused glass models without removing the **See•All** from the line. Replacement is through the bottom (see SA-14SU below). Request the K-SA-4 kit.
- Disassembly of the smaller sizes not required.** The extended steel fittings on solder models in the smaller sizes make it unnecessary to disassemble for installation since steel conducts only one eighth as much heat as copper.
- A double duty plastic cap** is supplied to keep the glass free from dust, dirt and grease. It also permits the service engineer to use his own discretion concerning instructions to his customers on observing the **See•All Moisture and Liquid Indicator**.

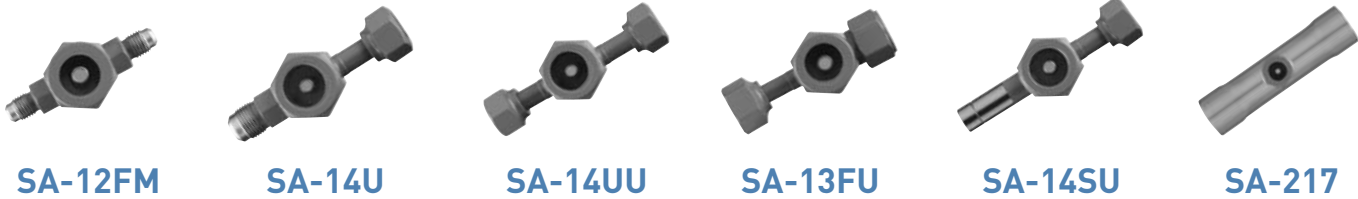

## Specifications

Listed by Underwriters' Laboratories, Inc. – Guide SEYW – File No. SA3182

CONNECTION SIZES Inches	MALE FLARE		FEMALE & MALE FLARE		MALE FLARE x SWIVEL NUT		SWIVEL NUT x SWIVEL NUT		FEMALE FLARE x SWIVEL NUT		SWIVEL NUT x ODF SOLDER		ODF SOLDER	
	TYPE NO.	OVERALL LENGTH Inches	TYPE NO.	OVERALL LENGTH Inches	TYPE NO.	OVERALL LENGTH Inches	TYPE NO.	OVERALL LENGTH Inches	TYPE NO.	OVERALL LENGTH Inches	TYPE NO.	OVERALL LENGTH Inches	TYPE NO.	OVERALL LENGTH Inches
1/4	SA-12	2.87	SA-12FM	2.56	—	—	—	—	—	—	—	—	SA-12S	4.62
3/8	SA-13	3.37	SA-13FM	2.97	SA-13U	3.64	SA-13UU	3.95	SA-13FU	3.19	SA-13SU	4.19	SA-13S	4.62
1/2	SA-14	3.81	SA-14FM	3.44	SA-14U	4.13	SA-14UU	4.50	SA-14FU	3.75	SA-14SU	4.62	SA-14S	4.87
5/8	SA-15	4.13	—	—	SA-15U	4.44	SA-15UU	4.75	—	—	SA-15SU	4.89	SA-15S	4.87
7/8	—	—	—	—	—	—	—	—	—	—	—	—	SA-17S	6.31
1-1/8	—	—	—	—	—	—	—	—	—	—	—	—	SA-19S	6.31
1-3/8	—	—	—	—	—	—	—	—	—	—	—	—	①SA-211	7.97
1-5/8	—	—	—	—	—	—	—	—	—	—	—	—	①SA-213	7.97
2-1/8	—	—	—	—	—	—	—	—	—	—	—	—	①SA-217	7.97

Maximum Rated Pressure for all models is 650 psig. Overall width is: 1.31" for 1/4" and 3/8" sizes. 1.58" for 1/2" and 5/8 sizes, and 1.38" for 7/8" and 1-1/8" sizes. Most solder connections can be used as male fittings as well as female fittings. The 1/4" ODF is 3/8" ODM, the 3/8" ODF is 1/2" ODM, the 1/2" ODF is 5/8" ODM, and the 5/8" ODF is 3/4" ODM. Models with female flare and/or swivel nut connections are supplied with a copper gasket in the fitting.

① These models have copper connections and feature a removable element cartridge – for replacement cartridge specify AC-20.

## Moisture Content PPM

SEE-ALL SHOWS LIQUID LINE TEMP.	R-12		R-22		R-134a		R-502		R-404A & R-507		R-407C	R-410A
	75°F	100°F	75°F	100°F	75°F	100°F	75°F	100°F	75°F	100°F	75°F	75°F
<b>Green DRY</b>	Below 5	Below 10	Below 30	Below 45	Below 50	Below 80	Below 10	Below 20	Below 15	Below 30	Below 120	Below 75
<b>Chartreuse CAUTION</b>	5-15	10-30	30-90	45-130	50-200	80-225	10-45	20-65	15-90	30-140	120-280	75-150
<b>Yellow WET</b>	Above 15	Above 30	Above 90	Above 130	Above 200	Above 225	Above 45	Above 65	Above 90	Above 140	Above 280	Above 150

Note: Change or add Catch-All Filter-Drier when paper turns from green to chartreuse.

For complete information see your Sporlan Wholesaler, our website at [www.sporlan.com](http://www.sporlan.com), or write Sporlan and request Bulletin 70-10.

# ▼ SUCTION FILTERS

WITH THE OPTIONAL RELIEF FEATURE

## Design Benefits

- Protects the compressor from dirt
- A relief device opens if the filter plugs
- Suitable for use with all brazing alloys
- Maximum corrosion resistance
- Full flow design for low pressure drop
- Complete line of sizes



SF-287-T

Sporlan offers an exclusive concept in Suction Filter design – a filter with an optional relief feature. When flow is in **one direction**, the bypass relief feature is active. If the pressure drop across the element becomes excessive the bypass relief will open slightly to maintain sufficient gas flow and assure proper cooling of the hermetic motor.

When the Suction Filter is installed with flow in the **opposite direction**, the bypass relief feature is inactive and will never open, regardless of the increase in pressure drop.

The “-T” in the type number indicates that these models are equipped with an access valve to permit pressure drop readings. The access valve will be operational provided the Suction Filters are installed with the bypass feature inactive.

TYPE		CONNECTIONS Inches	FILTER AREA Square Inches	DIMENSIONS - Inches		
WITHOUT Access Valve	WITH Access Valve			OVERALL LENGTH	SOCKET DEPTH	SHELL DIAMETER
<b>Types with bypass relief feature (Bi-directional Flow)</b>						
SF-283F	—	3/8 SAE Flare	28	8.78	—	3.00
—	SF-285-T	5/8 ODF Solder		8.34	0.62	
—	SF-286-T	3/4 ODF Solder		8.79	0.69	
—	SF-287-T	7/8 ODF Solder		8.93	0.75	
—	SF-289-T	1-1/8 ODF Solder		9.51	0.91	
—	SF-489-T	1-1/8 ODF Solder	48	12.42	0.91	
—	SF-4811-T	1-3/8 ODF Solder		13.10	0.97	
—	SF-4813-T	1-5/8 ODF Solder		13.44	1.09	
<b>Types without bypass relief feature (Single Flow Direction)</b>						
SF-114	—	1/2 ODF Solder	11	4.36	0.50	2.00
SF-114F	—	1/2 SAE Flare		5.25	—	
SF-115	—	5/8 ODF Solder		4.60	0.62	
SF-115F	—	5/8 SAE Flare		5.56	—	
—	SF-6417-T	2-1/8 ODF Solder	388	10.94	1.24	4.75
—	SF-6421-T	2-5/8 ODF Solder			1.38	



Listed by Underwriters' Laboratories, Inc. – Guide SMT – File No. SA-1756A & B.

## Selection Recommendations

TYPE NUMBER		CONNECTIONS Inches	① FLOW CAPACITY IN TONS EVAPORATOR TEMPERATURE																② NOMINAL SYSTEM HORSEPOWER				
WITHOUT Access Valve	WITH Access Valve		40°F				20°F				0°F				-20°F					-40°F			
			PRESSURE DROP																				
			2		3		1-1/2		2		1		1-1/2		1/2		1			1/2			
REFRIGERANT																REFRIGERANT							
		12	134a	22	407C	12	134a	22	404A	12	134a	22	404A	12	22	404A	22	404A	22, 407C	12, 134a, 404A, 502, 507			
SF-114	—	1/2 ODF	1.3	1.5	2.4	2.4	0.9	1.0	1.5	1.5	0.6	0.6	1.1	1.0	0.3	0.7	0.6	0.3	0.3	1	1/2		
SF-114F	—	1/2 SAE	1.2	1.3	2.1	2.1	0.8	0.9	1.4	1.3	0.5	0.5	0.9	0.9	0.3	0.6	0.5	0.3	0.3	1	1/2		
SF-115	—	5/8 ODF	2.3	2.6	4.1	4.1	1.6	1.7	2.7	2.6	1.0	1.1	1.8	1.7	0.5	1.2	1.1	0.6	0.6	2	1		
SF-115-F	—	5/8 SAE	2.1	2.3	3.7	3.7	1.4	1.5	2.4	2.3	0.9	0.9	1.6	1.5	0.5	1.0	0.9	0.5	0.5	2	1		
SF-283F	—	3/8 SAE	1.1	1.2	2.1	2.0	0.7	0.8	1.3	1.2	0.4	0.5	0.9	0.8	0.3	0.4	0.5	0.3	0.3	1	1/2		
—	SF-285-T	5/8 ODF	3.5	4.0	6.4	6.2	2.5	2.7	4.0	3.9	1.6	1.7	2.9	2.7	0.9	1.8	1.7	1.0	0.9	4	1-1/2		
—	SF-286-T	3/4 ODF	4.3	5.1	8.6	8.1	3.1	3.4	5.0	5.1	2.0	2.1	3.6	3.4	1.1	2.2	2.1	1.2	1.1	5	1-1/2		
—	SF-287-T	7/8 ODF	6.3	7.0	11.1	11.3	4.4	4.6	7.2	7.0	2.7	2.8	5.1	4.6	1.4	3.1	2.9	1.5	1.5	7-1/2	3		
—	SF-289-T	1-1/8 ODF	8.2	9.2	14.8	14.6	5.7	6.0	9.4	9.2	3.5	3.7	6.6	6.1	1.8	4.0	3.8	2.1	2.0	7-1/2	5		
—	SF-489-T	1-1/8 ODF	8.7	9.9	16.0	15.7	6.1	6.5	10.0	9.8	3.7	3.9	7.0	6.5	1.9	4.3	4.1	2.2	2.1	10	5		
—	SF-4811-T	1-3/8 ODF	9.9	11.2	18.4	18.0	6.8	7.3	11.4	11.2	4.2	4.4	7.9	7.4	2.2	4.8	4.6	2.5	2.4	12	5		
—	SF-4813-T	1-5/8 ODF	11.7	13.3	21.6	21.3	8.1	8.7	13.5	13.3	4.9	5.2	9.4	8.7	2.6	5.6	5.4	2.9	2.8	15	7		
—	SF-6417-T	2-1/8 ODF	46.7	50.9	91.1	88.9	28.7	31.0	56.9	52.6	15.8	16.4	35.4	31.8	7.2	20.3	17.8	9.3	7.9	55	20		
—	SF-6421-T	2-5/8 ODF	50.5	62.9	119.0	109.0	36.8	38.6	70.2	64.6	20.2	20.6	44.0	39.4	9.1	25.6	22.3	11.8	10.0	60	30		

Maximum Rated Pressure for SF-11, SF-28 and SF-48 Series is 400 psig. The SF-64 Series Shells are rated for 500 psig.

① Refrigerant 502 flow capacity is 80% of the values shown for Refrigerant 22, when expressed in TONS. When expressed in horsepower, the proper refrigerant selection is the same as for R-12. Use R-404A flow ratings for R-507.

② Use R-502 horsepower recommendations for R-402A & B and R-408A. Use R-12 horsepower recommendations for R-401A & B and R-409A. Ratings are in accordance with ARI Standard 730.

## ▼ REPLACEABLE SUCTION FILTERS

The Replaceable Suction Filter shell, used with RPE-48-BD pleated filter element, is designed to be installed in the suction line of new systems to remove circulating contaminants.

### Design Benefits

- High flow capacity
- Corrosion resistant coating on shell
- Can be used with desiccant cores for clean-up after burnout
- Various fitting sizes up to 3-1/8" line size
- Access valve supplied for pressure drop measurement or charging

### How It's Used

Sporlan Replaceable Suction Filters are installed in the suction line of refrigeration or air conditioning systems to remove contaminants that may be in the system at startup.

The Replaceable Suction Filter has large fittings permitting the use of a small shell on a system with large line sizes, resulting in considerable economy. The angle construction is suitable of flow in either direction, which results in easy installation even on compact racks.



**RSF-4817-T**

The Replaceable Suction Filters should be used with cores for cleaning up a system after a hermetic motor burnout. Select the RC-4864, RC-4864-HH or RCW-48 replaceable cores. After cleanup, install RPE-48-BD elements in the shells.

### Selection

The table below gives information for choosing the proper model for a given system. The filter elements are supplied in hermetically sealed metal cans.

**For flow capacity WITH CORES, see page 43.**

TYPE	CONNECTIONS Inches ODF SOLDER	FLOW CAPACITY IN TONS																				NUMBER OF FILTER ELEMENTS	FILTER AREA Square Inches	OVERALL LENGTH Inches					
		EVAPORATOR TEMPERATURE																											
		40°F					20°F					0°F					-20°F								-40°F				
		PRESSURE DROP – psi																											
		REFRIGERANT																											
12	134a	22	407C	410A	12	134a	22	404A	502	12	134a	22	404A	502	12	134a	22	404A	502	12	134a	22	404A	502					
RSF-487-T	7/8	7	7	12	11	13.8	5	5	7	7	7	2	3	5	4	4	1	1	3	3	2	1	1	1	1	One RPE-48-BD	388	9.30	
RSF-489-T	1-1/8	11	11	21	18	22	7	7	13	11	11	4	4	9	7	7	2	2	5	4	4	3	2	2	9.37				
RSF-4811-T	1-3/8	14	16	27	26	32	9	10	17	16	14	6	6	11	10	9	3	3	7	6	5	3	3	3	9.60				
RSF-4813-T	1-5/8	18	20	33	33	41	12	13	21	20	17	7	8	14	13	11	4	4	8	8	7	4	4	3	9.60				
RSF-4817-T	2-1/8	24	27	44	44	55	16	17	28	27	23	10	10	18	17	15	5	6	11	11	9	5	5	4	9.37				
RSF-4821-T	2-5/8	32	35	58	58	72	21	23	36	35	30	13	13	24	23	19	6	7	14	14	12	7	7	6	9.75				
RSF-9611-T	1-3/8	16	18	30	29	36	12	14	20	18	16	7	8	14	12	10	3	3	9	8	5	5	4	4	Two RPE-48-BD	776	15.14		
RSF-9613-T	1-5/8	20	22	40	38	47	15	18	27	24	19	10	11	19	16	13	4	5	12	10	7	7	6	5			15.14		
RSF-9617-T	2-1/8	26	29	48	47	59	17	19	30	29	25	10	11	20	18	16	5	6	13	11	9	7	7	5			14.96		
RSF-9621-T	2-5/8	35	40	65	65	81	23	26	41	40	34	14	15	27	26	22	7	8	16	16	13	8	8	6			15.43		
RSF-9625-T	3-1/8	49	55	90	89	111	32	35	57	55	47	19	20	37	35	30	10	12	25	22	18	11	10	9			15.12		

Listed by Underwriters' Laboratories, Inc. Guide SMGT File No. SA-1756A & B. RSF shells have a 500 psig M.R.P. rating.  
**Note:** Use R-404A ratings for R-507. Use R-502 horsepower recommendations for R-402A & B and R-408A. Use R-12 horsepower recommendations for R-401 A & B and R-409A.  
 Ratings are in accordance with ARI Standards 730. Flow capacity (tons) with cores is approximately 40% of the above values.  
**For complete information see your Sporlan Wholesaler, our website at [www.sporlan.com](http://www.sporlan.com), or write Sporlan and request Bulletin 80-10.**

## ▼ STRAINERS

REFRIGERANTS – BRINE – WATER



Sporlan "Y" Type Strainers are designed for use in refrigerant liquid or suction lines, brine and water applications. They provide protection for controls and operating machinery against foreign material encountered in a system, while providing for free flow with negligible pressure drop.

**For complete information see your Sporlan Wholesaler, our website at [www.sporlan.com](http://www.sporlan.com), or write Sporlan and request Bulletin 80-20.**

TYPE NO.	CONNECTION SIZE Inches	SCREEN AREA IN Sq. In.	MESH SIZE
6022	1/4 FPT	2	80
6023	3/8 FPT		
6034	1/2 FPT	3	40
6056	3/4 FPT	5	
6088	1 FPT	8	

## ▼ DISCHARGE BYPASS VALVES



SHGB-15



ADRI



ADRHE-6

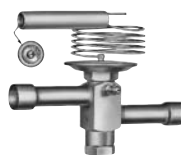

DRHE-6



HGBE-5



SHGB-8

UL and SF LISTED or Recognized

The Sporlan line of discharge bypass valves are designed to provide an economical method of compressor capacity control in place of cylinder unloaders or to handle unloading requirements below the last step of cylinder unloading. These modulating control valves automatically bypass the required amount of discharge gas to the low side to maintain the desired minimum evaporator pressure. The valves are applicable on any refrigeration or air conditioning system that operates during periods of low load, which can result in coil icing or short cycling. These valves respond to downstream pressure changes and open when the evaporator pressure falls below the valve setting. At normal loads and evaporator conditions, the valve remains closed and the system operates in a conventional manner.

**The DR line of valves consists of three basic types of valves: the adjustable models, the adjustable remote bulb models, and the non-adjustable models (contact Sporlan for information).**

**The SHGB valves are adjustable and pilot operated with a solenoid stop feature that eliminates the need for a hot gas solenoid valve. They were developed for use on larger capacity systems.**

### Application

The discharge bypass valve is normally applied in a branch line off the discharge line. To allow system pump down control, a solenoid valve or hand valve must be installed upstream of the discharge DR type bypass valves. The bypassed hot gas can enter the low side at several locations; however, two of the possible locations are preferred because of superior operating performance: into the side connection of a Sporlan side connection distributor or directly into the suction line. By using the side connection distributor method, the system TEV will

act as a desuperheating valve to keep the compressor suction temperature below the recommended maximum temperature published by the compressor manufacturer. When the hot gas is bypassed directly into the suction line, an auxiliary desuperheating TEV may be required. See Bulletin 90-40, 90-40-1, and Bulletin R-410A for complete application details.

### Selection and Capacity Ratings

The capacities given in the table below are **valve** hot gas capacities and not the capacities of the system on which the valve is to be applied. To select a valve, first determine the compressor capacity at the minimum allowable evaporating temperature. Then the discharge bypass valve must supply the difference between this compressor capacity and the minimum evaporator load at which the system is to be operated. The valve pressure setting will be that pressure at which the bypass valve must start to open.

Connections – (Standard Connections are in **BOLD** type. Non-standard connections may be subject to availability and/or require a minimum quantity).

**ADRI(E)-1-1/4, - 3/8"** ODF Solder

**ADRS(E)-2** – 3/8", 1/2", 5/8" ODF Solder or 3/8", 1/2", 5/8" SAE Flare

**ADRP(E)-3** – 1/2", 5/8", ODF Solder on 1/2", 5/8" SAE Flare

**ADRHE-6 & DRHE-6** – 5/8", 7/8", 1-1/8" ODF Solder

**SHGB(E)-8** – 7/8" ODF, 1-1/8" ODF Solder

**SHGB(E)-15** – 1-1/8", 1-3/8" ODF Solder

Valves with ODF solder connections are supplied standard with 1/4" ODF external equalizer, 1/4" SAE Flare external equalizer available on special order. Pilot operated models are supplied with 1/4" SAE external equalizer.

## ▼ DISCHARGE BYPASS VALVES

### Capacities – Tons

Capacities based on 6°F evaporator temperature change from closed to rated opening (does not apply to pilot operated models), discharge temperature 30°F above isentropic compression, 100°F condensing temperature, 0°F subcooling, 25°F superheat at the compressor and includes both the hot gas bypassed and liquid refrigerant for desuperheating, regardless of whether the liquid is fed through the system thermostatic expansion valve or auxiliary desuperheating thermostatic expansion valve.

REFRIGERANT	MINIMUM ALLOWABLE EVAPORATOR TEMPERATURE	VALVE TYPE & ADJUSTMENT RANGE (psig)														
		ADRI-1-1/4 ADRIE-1-1/4		ADRS-2 ASRSE-2		ADRP-3 ADRPE-3		ADRHE-6		DRHE-6 (Adjustable "Remote Bulb" Model)*				SHGB-8 SHGBE-8	SHGB-15 SHGBE-15	
		0/55	0/75	0/100	0/30	0/80	0/30	0/80	0/30	0/80	25/35	32/44	55/70	65/80	0/100	0/80
22	40	—	0.58	0.53	—	3.51	—	5.99	—	9.16	—	—	19.8	—	15.5	43.0
	26	0.44	0.64	0.54	—	3.57	—	6.26	—	9.90	—	—	16.9	—	15.8	47.4
	0	0.63	0.60	0.49	3.90	3.66	7.38	6.61	13.9	10.9	—	—	—	—	16.1	52.6
	-20	0.59	0.50	0.44	3.75	3.65	7.45	6.64	14.1	11.0	—	—	—	—	16.2	55.3
134a	40	0.40	0.43	0.34	—	2.67	—	4.94	—	9.34	9.64	—	—	—	10.8	30.6
	26	0.41	0.39	0.32	2.60	2.44	4.95	4.42	9.36	7.26	8.31	—	—	—	10.9	33.2
	0	0.38	0.31	0.28	2.46	—	4.89	—	9.41	—	—	—	—	—	11.0	36.4
401A	40	0.45	0.48	0.39	—	2.76	—	4.95	—	7.99	—	11.0	—	—	10.6	29.6
	26	0.47	0.45	0.37	2.97	2.79	5.66	5.04	10.7	8.26	—	9.49	—	—	10.7	32.4
	0	0.44	0.36	0.32	2.83	2.74	5.62	5.01	10.8	8.32	—	—	—	—	10.8	35.7
404A	40	—	—	0.55	—	—	—	—	—	—	—	—	—	—	17.2	48.6
	26	—	0.67	0.60	—	3.91	—	6.70	—	10.4	—	—	—	21.4	17.5	53.2
	0	0.67	0.71	0.56	—	4.00	—	7.16	—	11.7	—	—	—	—	17.6	58.8
	-20	0.68	0.61	0.51	4.17	4.02	8.08	7.28	15.3	12.1	—	—	—	—	17.6	61.5
407C	40	—	0.78	0.65	—	4.25	—	7.50	—	12.1	—	—	22.9	—	15.9	44.6
	26	0.61	0.78	0.63	—	4.25	—	7.50	—	12.1	—	19.3	—	—	16.1	48.8
	0	0.74	0.68	0.56	4.51	4.31	8.63	7.81	16.3	13.0	—	—	—	—	16.3	53.8
	-20	0.68	0.56	0.50	4.33	4.23	8.64	7.71	16.5	12.9	—	—	—	—	16.4	56.3
507	40	—	—	0.53	—	—	—	—	—	—	—	—	—	—	17.2	48.6
	26	—	0.65	0.59	—	3.87	—	6.60	—	10.2	—	—	—	—	17.5	53.2
	0	—	0.71	0.57	—	3.96	—	7.09	—	11.5	—	—	—	—	17.6	58.8
	-20	0.69	0.62	0.52	4.17	4.00	8.02	7.25	15.2	12.0	—	—	—	—	17.6	61.5

\*These models applicable on air conditioning systems only.

For complete information see your Sporlan Wholesaler, our website at [www.sporlan.com](http://www.sporlan.com), or write Sporlan and request Bulletin 90-40.

### Capacities – Tons – R-410A

REFRIGERANT	VALVE TYPE	ADJUSTMENT RANGE (psig)	MINIMUM ALLOWABLE EVAPORATOR TEMPERATURE AT REDUCED LOAD °F								
			40			26			20		
			CONDENSING TEMPERATURE °F								
			80	100	120	80	100	120	80	100	120
410A	HGBE-5	95/115	4.27	5.43	6.76	4.29	5.46	6.80	4.30	5.47	6.81
	HGB-8	75/150	18.9	25.2	31.9	19.8	25.8	32.2	20.2	25.9	32.3
	HGBE-8										

Capacities based on discharge temperatures 50°F (28°C) above isentropic compression, 25°F (14°C) superheat at the compressor, 10°F (5°C) subcooling, and includes both the hot gas bypassed and liquid refrigerant for desuperheating, regardless of whether the liquid is fed through the system thermostatic expansion valves or an auxiliary desuperheating thermostatic expansion valve.

For complete information see your Sporlan Wholesaler, our website at [www.sporlan.com](http://www.sporlan.com), or write Sporlan and request Bulletin R-410A.

# ▼ CRANKCASE PRESSURE REGULATING VALVES



Crankcase Pressure Regulating Valves are designed to prevent overloading of the compressor motor by limiting the crankcase pressure to a predetermined maximum value during and after a defrost cycle or a normal shutdown period. These valves automatically throttle the vapor flow from the evaporator until the compressor can handle the load.



Sporlan manufactures five adjustable direct acting models...CRO-4, CRO-6, CROT-6, CRO-10 and CROT-10...all models respond only to their outlet pressure and modulate to prevent the suction pressure at the compressor from rising above the valve setting. Since these valves are adjustable, the setting may be altered to suit the specific system requirements.

## Selection and Capacity Ratings

The ratings for these valves vary depending on these items: design suction pressure after pulldown, maximum allowable suction pressure recommended by the compressor or unit manufacturer (this is the valve setting), and pressure drop across the valve. The difference between the design suction pressure and the valve setting determines how much of the valve stroke is used. Therefore, the valve setting should be kept as high as possible without exceeding the recommendation of the compressor or unit manufacturer. Once this information is available, the correct CRO can be selected from the data below.

Connections – (Standard Connections are in **BOLD** type).

**CRO-4** – 3/8", 1/2" ODF Solder and 3/8", 1/2" SAE Flare

**CRO-6**, \***CROT-6** – 5/8", 7/8", 1-1/8" ODF Solder and 1/2", 5/8" SAE Flare.

**CRO-10**, \***CROT-10** – 7/8", 1-1/8", 1-3/8" ODF Solder.

\*"T" indicates access valve on inlet connection.

## Capacities – Tons

Capacities based on 100°F condensing temperature, 10°F superheat, 0°F subcooling, and 2 psi pressure drop across valve.

TYPE and ADJUSTMENT RANGE	DESIGN EVAPORATOR TEMPERATURE °F	SATURATED SUCTION PRESSURE – psig (Reference)	R-22						SATURATED SUCTION PRESSURE – psig (Reference)	R-134a					
			VALVE SETTING – psig							VALVE SETTING – psig					
			10	20	30	40	50	60		10	20	30	40	50	60
<b>CRO-4</b> 0/20	-40	0.6	0.17	0.20	—	—	—	—	14.7	0.10	0.10	—	—	—	—
	-30	4.9	0.17	0.20	—	—	—	—	9.7	0.12	0.12	—	—	—	—
	-20	10.2	—	0.23	—	—	—	—	3.6	0.15	0.15	—	—	—	—
	-10	16.5	—	0.21	—	—	—	—	2.0	0.17	0.18	—	—	—	—
<b>CRO-4</b> 0/50	-40	0.6	0.14	0.19	0.24	0.17	0.17	—	14.7	0.09	0.10	0.10	0.10	0.10	—
	-30	4.9	0.14	0.19	0.20	0.20	0.20	—	9.7	0.11	0.12	0.12	0.12	0.12	—
	-20	10.2	—	0.19	0.23	0.23	0.23	—	3.6	0.12	0.15	0.15	0.15	0.15	—
	-10	16.5	—	0.18	0.24	0.27	0.27	—	2.0	0.13	0.17	0.18	0.18	0.18	—
	0	24.0	—	—	0.22	0.29	0.30	—	6.5	0.14	0.18	0.21	0.21	0.21	—
	10	32.8	—	—	—	0.26	0.33	—	12.0	—	0.19	0.24	0.24	0.24	—
<b>CRO-4</b> 0/75	20	43.1	—	—	—	—	0.29	—	18.4	—	—	0.24	0.28	0.28	—
	-40	0.6	0.13	0.17	0.22	0.17	0.17	0.17	14.7	0.08	0.10	0.10	0.10	0.10	0.10
	-30	4.9	0.14	0.17	0.20	0.20	0.20	0.20	9.7	0.10	0.12	0.12	0.12	0.12	0.12
	-20	10.2	—	0.18	0.22	0.23	0.23	0.23	3.6	0.12	0.14	0.15	0.15	0.15	0.15
	-10	16.5	—	0.18	0.22	0.27	0.27	0.27	2.0	0.13	0.16	0.18	0.18	0.18	0.18
	0	24.0	—	—	0.22	0.29	0.30	0.30	6.5	0.14	0.17	0.21	0.21	0.21	0.21
	10	32.8	—	—	—	0.25	0.31	0.34	12.0	—	0.18	0.24	0.24	0.24	0.24
<b>CRO(T)-6</b> 0/60	20	43.1	—	—	—	—	0.28	0.34	18.4	—	—	0.22	0.27	0.28	0.28
	30	55.0	—	—	—	—	—	—	26.1	—	—	0.21	0.27	0.32	0.32
	-40	0.6	0.46	0.71	0.97	1.21	1.21	1.21	14.7	0.35	0.51	0.68	0.71	0.71	0.71
	-20	10.2	—	0.66	0.97	1.32	1.62	1.62	3.6	0.43	0.66	0.88	1.05	1.05	1.05
	-10	16.5	—	0.52	0.90	1.27	1.65	1.85	2.0	0.43	0.69	0.95	1.21	1.24	1.24
	0	24.0	—	—	0.71	1.13	1.55	1.97	6.5	0.38	0.68	0.98	1.28	1.45	1.45
<b>CRO(T)-10</b> 0/60	10	32.8	—	—	—	0.86	1.33	1.81	12.0	—	0.62	0.95	1.30	1.64	1.67
	20	43.1	—	—	—	—	0.96	1.48	18.4	—	0.47	0.85	1.24	1.63	1.92
	30	55.0	—	—	—	—	—	0.96	26.1	—	—	0.64	1.08	1.52	1.96
	-40	0.6	1.48	2.78	2.78	2.78	2.78	2.78	14.7	1.72	1.76	1.76	1.76	1.76	1.76
	-20	10.2	—	2.01	3.63	3.63	3.63	3.63	3.6	1.61	2.44	2.44	2.44	2.44	2.44
	-10	16.5	—	0.80	3.15	4.11	4.11	4.11	2.0	1.28	2.83	2.83	2.83	2.83	2.83
<b>CRO(T)-6</b> 30/110	0	24.0	—	—	1.57	4.20	4.63	4.63	6.5	0.63	2.50	3.26	3.26	3.26	3.26
	10	32.8	—	—	—	2.11	5.06	5.18	12.0	—	1.70	3.74	3.74	3.74	3.74
	20	43.1	—	—	—	—	2.27	5.55	18.4	—	0.37	2.79	4.25	4.25	4.25
	30	55.0	—	—	—	—	—	1.84	26.1	—	—	1.07	3.81	4.81	4.81
	40	68.6	—	—	—	—	—	—	35.0	—	—	—	—	—	—
<b>CRO(T)-10</b> 30/110	0	24.0	2.84	4.62	4.62	4.62	4.62	4.62	6.5	3.26	3.26	3.26	3.26	3.26	3.26
	10	32.8	1.43	3.42	5.18	5.18	5.18	5.18	12.0	3.74	3.74	3.74	3.74	3.74	3.74
	20	43.1	—	1.54	3.76	5.77	5.77	5.77	18.4	3.53	4.25	4.25	4.25	4.25	4.25
	30	54.9	—	—	1.25	3.71	6.17	6.40	26.1	2.58	4.43	4.81	4.81	4.81	4.81
	40	68.6	—	—	—	—	3.12	5.84	35.0	1.04	3.12	5.21	5.42	5.42	5.42

Numbers shown in italic indicate vacuum in inches.

# ▼ CRANKCASE PRESSURE REGULATING VALVES

## Capacities – Tons

Capacities based on 100°F condensing temperature, 10°F superheat, 0°F subcooling, and 2 psi pressure drop across valve.

TYPE and ADJUSTMENT RANGE	DESIGN EVAPORATOR TEMPERATURE °F	SATURATED SUCTION PRESSURE – psig (Reference)	R-404A						SATURATED SUCTION PRESSURE – psig (Reference)	R-507					
			VALVE SETTING – psig							VALVE SETTING – psig					
			10	20	30	40	50	60		10	20	30	40	50	60
CRO-4 0/20	-40	4.6	0.11	0.13	—	—	—	—	5.5	0.11	0.13	—	—	—	—
	-30	9.9	—	0.16	—	—	—	—	11.1	—	0.16	—	—	—	—
	-20	16.3	—	0.15	—	—	—	—	17.8	—	0.13	—	—	—	—
CRO-4 0/50	-40	4.6	0.10	0.12	0.13	0.13	0.13	—	5.5	0.09	0.12	0.13	0.13	0.13	—
	-30	9.9	—	0.13	0.16	0.16	0.16	—	11.1	—	0.13	0.16	0.16	0.16	—
	-20	16.3	—	0.13	0.16	0.19	0.19	—	17.8	—	0.12	0.16	0.19	0.19	—
	-10	24.0	—	—	0.14	0.20	0.22	—	25.8	—	—	0.15	0.20	0.22	—
	0	33.0	—	—	—	0.19	0.24	—	35.2	—	—	—	0.18	0.23	—
	10	43.5	—	—	—	—	0.22	—	46.2	—	—	—	—	0.20	—
CRO-4 0/75	-40	4.6	0.09	0.11	0.13	0.13	0.13	0.13	5.5	0.09	0.11	0.13	0.13	0.13	0.13
	-30	9.9	—	0.12	0.15	0.16	0.16	0.16	11.1	—	0.12	0.15	0.16	0.16	0.16
	-20	16.3	—	0.13	0.15	0.19	0.19	0.19	17.8	—	0.12	0.15	0.18	0.19	0.19
	-10	24.0	—	—	0.14	0.19	0.22	0.22	25.8	—	—	0.15	0.18	0.22	0.22
	0	33.0	—	—	—	0.18	0.22	0.25	35.2	—	—	—	0.17	0.21	0.25
	10	43.5	—	—	—	—	0.21	0.25	46.2	—	—	—	—	0.19	0.24
CRO(T)-6 0/60	-40	4.6	0.28	0.48	0.67	0.86	0.94	0.94	5.5	0.26	0.46	0.65	0.85	0.93	0.93
	-20	16.3	—	0.37	0.63	0.89	1.17	1.30	17.8	—	—	0.59	0.85	1.10	1.29
	-10	24.0	—	—	0.51	0.81	1.13	1.40	25.8	—	—	0.45	0.75	1.04	1.35
	0	33.0	—	—	—	0.62	0.99	1.30	35.2	—	—	—	0.54	0.87	1.23
	10	43.5	—	—	—	—	0.72	1.08	46.2	—	—	—	—	0.58	0.98
	20	55.7	—	—	—	—	—	0.23	58.8	—	—	—	—	—	0.21
CRO(T)-10 0/60	-40	4.6	0.63	1.86	2.12	2.12	2.12	2.12	5.5	0.52	1.75	2.11	2.11	2.11	2.11
	-20	16.3	—	0.59	2.24	2.88	2.88	2.88	17.8	—	—	1.97	2.86	2.86	2.86
	-10	24.0	—	—	1.14	3.01	3.32	3.32	25.8	—	—	0.77	2.65	3.29	3.29
	0	33.0	—	—	—	1.51	3.80	3.80	35.2	—	—	—	1.03	3.10	3.75
	10	43.5	—	—	—	—	1.75	3.97	46.2	—	—	—	—	0.88	3.30
CRO(T)-6 30/110	0	33.0	0.54	0.79	1.00	1.23	1.49	1.69	35.2	0.49	0.71	0.95	1.18	1.40	1.63
	10	43.5	—	0.63	0.87	1.13	1.43	1.65	46.2	—	—	0.80	1.07	1.31	1.58
	20	55.7	—	—	0.63	0.93	1.26	1.51	58.8	—	—	—	0.84	1.12	1.42
	30	69.7	—	—	—	—	0.95	1.23	73.3	—	—	—	—	0.78	1.12
CRO(T)-10 30/110	0	33.0	1.02	2.57	3.80	3.80	3.80	3.80	35.2	0.70	2.10	3.60	3.75	3.75	3.75
	10	43.5	—	1.18	2.69	4.32	4.32	4.32	46.2	—	—	2.30	3.95	4.26	4.26
	20	55.7	—	—	0.76	2.64	4.70	4.89	58.8	—	—	—	2.12	3.86	4.81
	30	69.7	—	—	—	—	2.34	4.13	73.3	—	—	—	—	1.33	3.44

CRO-6 & CRO-10 are listed by Underwriters Laboratories, Inc. – Guide – SFJQ – File No. SA5460 and Canadian Standards Association – Certification Record No. LR-19953.  
CRO-4 is a recognized component UL Guide No. SFJQ8, File Number SA5460, also a recognized component in Canada.

## Installation

Crankcase pressure regulating valves are installed in the suction line between the evaporator and compressor, and downstream of any other controls or accessories. When installing CRO's with solder type connections, the internal parts should be protected by wrapping the valve with a wet cloth.

For complete information see your Sporlan Wholesaler, our website at [www.sporlan.com](http://www.sporlan.com), or write Sporlan and request Bulletin 90-10.

## ▼ HEAD PRESSURE CONTROL VALVES



**ORI-6**

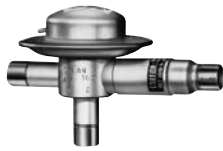

**OROA-5**



**ORD-4**



**LAC-4**

Listed by Underwriters' Laboratories, Inc. Guide SFJQ2 File No. SA5460



**LAC-4-DS**



**LAC-10**

Sporlan Head Pressure Control for systems with air cooled condensers can be accomplished with several valve types or the ORI/ORD combination. The valve types are: LAC-4, OROA-5, LAC-5 and the LAC-10.

Please refer to Bulletin 90-30 or Bulletin R-410A for a complete explanation of operation and application. The equipment manufacturer should be consulted to determine the additional refrigerant charge required when applying this type of head pressure control to a system. However, if this information is not available from the OEM, Bulletin 90-30-1 shows two methods for calculating the correct amount of extra refrigerant charge.

Figures 2, 3 and 4 are piping schematics illustrating the general location of the head pressure control valves listed above. Figure 2 includes an auxiliary check valve in the liquid line between the LAC and the receiver. This check valve should be installed in this instance to prevent refrigerant migration from the warm receiver to the cold condenser during the off cycle. Industry piping procedures must be followed to prevent liquid accumulation on the compressor head during system shutdown. Sporlan recommends that recognized piping references be consulted for assistance in this regard. Sporlan is not responsible for system design, any damage arising from faulty system design, or for misapplication of its products.

The LAC, OROA and ORI are designed for application in the liquid line and should not be applied in the discharge line for any reason. Compressor pulsations can greatly shorten the life of the valves. If any of the valves are applied in any manner other than described here, the Sporlan warranty is void.

LAC-4-DS (Dual Setting) – The standard LAC-4 has a dome element with a fixed setting. The dual setting feature allows a choice between two fixed settings. The element has an internal spring which is set to maintain the lower setting. The element is then charged with air to obtain the higher setting and the capillary tube is pinched and fused. An example is an LAC-4-100/180-DS. If the capillary tube is left intact the valve will maintain a 180 psig setting. If the capillary tube is clipped then fused again, the valve will maintain a 100 psig setting. It is important to fuse the capillary tube tip after clipping to prevent moisture from entering the element.

### Capacities

Ratings for the common refrigerants are given at several pressure drops for the ORI's, OROA and LAC on the next page. Maximum capacities for the ORD-4 are given also. Normally, a 2 psi pressure drop across the ORI or OROA is recommended; however, this can be exceeded provided the total pressure drop through the condenser and ORI or OROA does not exceed 14 psi for most applications.

Therefore, to select either valve combination, it is necessary to know the system tonnage and refrigerant, the approximate pressure drop through the condenser, the desired pressure setting for the OROA-5 or LAC and the connections necessary. The standard pressure settings for the OROA, and LAC are 100 psig for Refrigerant 134a, 180 psig for Refrigerants 22 and 502 and 215 psig for Refrigerants 402A, 404A and 507. Other pressure settings are available on special order. The standard pressure setting for the LAC for R-410A is 295 psig.

The ORI, OROA and LAC connection size should be at least the same size as the outlet on the condenser where possible. Oversizing these valves is not harmful.

On large systems these valves can be applied in parallel.

**Figure 2**

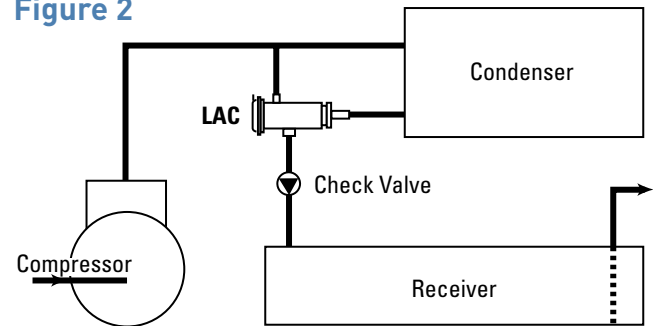

**Figure 3**

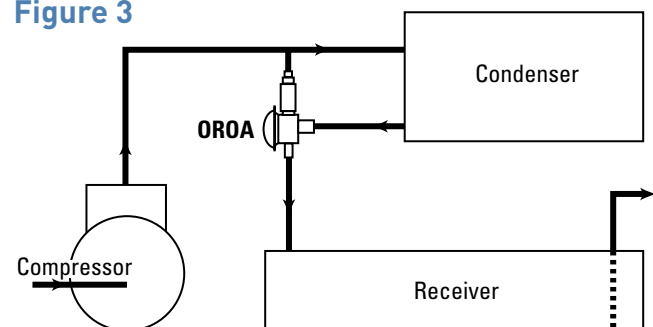

**Figure 4**

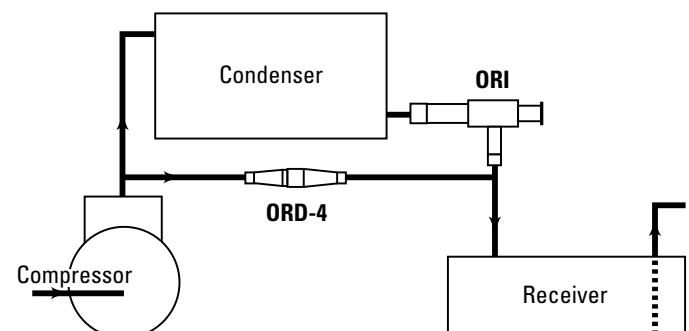

## ▼ HEAD PRESSURE CONTROL VALVES

### Low Ambient (Winter) Capacities – Tons Of Refrigeration

Capacities are based on 0°F evaporator temperature, 94°F condenser, 10°F subcooled liquid.

REFRIGERANT Valve Setting (psig)	MINIMUM AMBIENT DESIGN TEMP. °F	PRESSURE DROP ACROSS VALVE (psi)	VALVE TYPE					
			LAC-4	LAC-5	LAC-10	OROA-5	ORD-4	
<b>22</b> (180)	-20	1	1.71	3.04	7.30	—	—	
		2	2.41	4.29	10.2	—	—	
		5	3.77	6.77	15.9	—	—	
		10	5.26	9.53	22.1	—	—	
		15	6.37	11.6	26.7	—	—	
		20	7.28	13.4	30.3	—	—	
		30	8.05	14.9	33.4	18.3	18.3	
	0	1	1.85	3.28	7.85	—	—	
		2	2.60	4.63	11.0	—	—	
		5	4.07	7.30	17.1	—	—	
		10	5.69	10.3	23.7	—	—	
		15	6.88	12.5	28.6	—	—	
		20	7.86	14.4	32.5	—	—	
		30	8.70	16.1	35.8	21.0	21.0	
	20	1	2.03	3.58	8.57	—	—	
		2	2.86	5.06	12.0	—	—	
		5	4.46	7.99	18.6	—	—	
		10	6.22	11.3	25.8	—	—	
		15	7.53	13.7	31.1	—	—	
		20	8.60	15.8	35.3	—	—	
		30	9.51	17.6	38.8	25.2	25.2	
	<b>134a</b> (100)	-20	1	1.36	2.42	5.83	—	—
			2	1.91	3.41	8.17	—	—
			5	2.98	5.37	12.7	—	—
10			4.13	7.54	17.4	—	—	
15			4.96	9.17	20.8	—	—	
20			5.62	10.5	23.4	—	—	
30			6.16	11.6	25.4	13.0	13.0	
0		1	1.48	2.64	6.34	—	—	
		2	2.09	3.72	8.88	—	—	
		5	3.25	5.86	13.7	—	—	
		10	4.51	8.23	18.9	—	—	
		15	5.42	10.0	22.5	—	—	
		20	6.14	11.5	25.3	—	—	
		30	6.73	12.7	27.6	15.0	15.0	
20		1	1.66	2.94	7.03	—	—	
		2	2.33	4.15	9.84	—	—	
		5	3.63	6.53	15.2	—	—	
		10	5.03	9.16	20.9	—	—	
		15	6.04	11.1	24.9	—	—	
		20	6.84	12.8	28.0	—	—	
		30	7.51	14.2	30.4	18.1	18.1	
<b>410A</b> (295)		-20	1	1.74	3.09	5.83	—	—
			2	2.46	4.37	8.18	—	—
			5	3.85	6.90	12.8	—	—
	10		5.40	9.74	17.8	—	—	
	0	1	1.88	3.33	6.27	—	—	
		2	2.65	4.71	8.79	—	—	
		5	4.16	7.44	13.7	—	—	
	20	1	2.06	3.63	6.82	—	—	
		2	2.90	5.14	9.56	—	—	
		5	4.54	8.11	14.9	—	—	
10	6.35	11.4	20.7	—	—			

REFRIGERANT Valve Setting (psig)	MINIMUM AMBIENT DESIGN TEMP. °F	PRESSURE DROP ACROSS VALVE (psi)	VALVE TYPE					
			LAC-4	LAC-5	LAC-10	OROA-5	ORD-4	
<b>404A</b> (210)	-20	1	1.19	2.11	5.10	—	—	
		2	1.67	2.99	7.16	—	—	
		5	2.62	4.71	11.2	—	—	
		10	3.67	6.64	15.5	—	—	
		15	4.45	8.10	18.7	—	—	
		20	5.09	9.32	21.3	—	—	
		30	5.64	10.4	23.6	12.4	12.4	
	0	1	1.27	2.25	5.42	—	—	
		2	1.79	3.19	7.61	—	—	
		5	2.81	5.03	11.9	—	—	
		10	3.92	7.08	16.5	—	—	
		15	4.75	8.64	19.9	—	—	
		20	5.44	9.94	22.6	—	—	
		30	6.02	11.1	25.0	13.9	13.9	
	20	1	1.38	2.44	5.85	—	—	
		2	1.94	3.45	8.20	—	—	
		5	3.04	5.44	12.7	—	—	
		10	4.25	7.67	17.7	—	—	
		15	5.15	9.35	21.3	—	—	
		20	5.89	10.8	24.3	—	—	
		30	6.52	12.0	26.8	16.4	16.4	
	<b>507</b> (210)	-20	1	1.17	2.08	5.02	—	—
			2	1.65	2.94	7.05	—	—
			5	2.59	4.64	11.0	—	—
10			3.62	6.54	15.3	—	—	
15			4.38	7.98	18.4	—	—	
20			5.01	9.18	21.0	—	—	
30			5.55	10.2	23.2	12.3	12.3	
0		1	1.27	2.24	5.39	—	—	
		2	1.78	3.17	7.56	—	—	
		5	2.79	5.00	11.8	—	—	
		10	3.90	7.05	16.3	—	—	
		15	4.73	8.60	19.7	—	—	
		20	5.40	9.89	22.4	—	—	
		30	5.98	11.0	24.8	14.1	14.1	
20		1	1.39	2.45	5.86	—	—	
		2	1.95	3.46	8.21	—	—	
		5	3.05	5.46	12.8	—	—	
		10	4.26	7.69	17.7	—	—	
		15	5.16	9.39	21.4	—	—	
		20	5.90	10.8	24.3	—	—	
		30	6.54	12.0	26.8	17.0	17.0	

# ▼ HEAD PRESSURE CONTROL VALVES

## High Ambient (Summer) Capacities – Tons Of Refrigeration

Capacities are based on 0°F evaporator temperature, 110°F condenser, 10°F subcooled liquid.

REFRIGERANT	PRESSURE DROP ACROSS VALVE (psi)	VALVE TYPE						
		LAC-4	LAC-5	LAC-10	OROA-5	ORI-6	ORI-10	ORD-4
22	1	2.57	5.50	11.7	10.4	7.35	19.7	—
	2	3.59	7.78	16.3	14.7	10.7	27.2	—
	3	4.37	9.53	19.7	17.9	13.3	32.8	—
	4	5.02	11.0	22.6	20.7	15.5	37.5	—
	5	5.60	12.3	25.1	23.1	17.5	41.6	—
	6	6.11	13.5	27.3	25.3	19.4	45.3	—
	8	7.02	15.6	31.3	29.2	22.6	51.8	—
	10	7.82	17.4	34.8	32.6	25.5	57.5	—
134a	1	2.30	4.92	10.5	9.31	4.90	12.2	—
	2	3.22	6.96	14.5	13.1	7.13	16.8	—
	3	3.91	8.53	17.6	16.1	8.88	20.3	—
	4	4.49	9.85	20.2	18.5	10.4	23.2	—
	5	5.01	11.0	22.4	20.7	11.7	25.8	—
	6	5.47	12.1	24.5	22.6	12.9	28.0	—
	8	6.28	13.9	28.0	26.1	15.1	32.1	—
	10	7.00	15.6	31.2	29.2	17.0	35.6	—
410A	1	2.44	5.22	8.23	—	—	—	—
	2	3.42	7.38	11.4	—	—	—	—
	3	4.15	9.04	13.9	—	—	—	—
	4	4.77	10.4	15.9	—	—	—	—
	5	5.32	11.7	17.6	—	—	—	—

REFRIGERANT	PRESSURE DROP ACROSS VALVE (psi)	VALVE TYPE							
		LAC-4	LAC-5	LAC-10	OROA-5	ORI-6	ORI-10	ORD-4	
404A	1	1.61	3.43	7.33	6.49	5.01	13.9	—	
	2	2.25	4.85	10.2	9.15	7.29	19.3	—	
	3	2.73	5.94	12.3	11.2	9.07	23.3	—	
	4	3.14	6.86	14.1	12.9	10.6	26.6	—	
	5	3.50	7.67	15.7	14.4	12.0	29.5	—	
	6	3.82	8.40	17.1	15.8	13.2	32.1	—	
	8	4.39	9.70	19.6	18.2	15.4	36.7	—	
	10	4.89	10.8	21.8	20.3	17.4	40.7	—	
	507	1	1.57	3.36	7.17	6.36	4.94	13.7	—
		2	2.20	4.75	9.96	8.96	7.19	18.9	—
3		2.67	5.82	12.1	11.0	8.95	22.9	—	
4		3.07	6.72	13.8	12.6	10.4	26.2	—	
5		3.42	7.51	15.4	14.1	11.8	29.0	—	
6		3.74	8.23	16.8	15.4	13.0	31.6	—	
8		4.30	9.51	19.2	17.8	15.2	36.1	—	
10		4.79	10.6	21.3	19.9	17.1	40.1	—	

### Installation

The ORI, OROA and LAC valves are installed in the condenser liquid drain line and the ORD is installed in a hot gas bypass line around the condenser. When installing these valves, the internal parts should be protected by wrapping the valves with wet cloths.

#### Connections:

- OROA-5** – Discharge Connection: 5/8" ODF  
Receiver and Condenser Connections: 5/8" or 7/8" ODF
- LAC-4** – 1/4", 3/8", 1/2" ODF Solder
- LAC-5** – 1/2", 5/8", 7/8", 1-1/8" ODF Solder

- LAC-10** – Discharge Connection: 1-3/8" ODF Solder  
Receiver and Condenser Connections: 7/8" or 1-1/8" ODF Solder
- ORI-6** – 5/8", 7/8", 1-1/8" ODF Solder
- ORI-10** – 1-1/8", 1-3/8" ODF Solder
- ORD-4** – 5/8" ODF Solder

For complete information see your Sporlan Wholesaler, our website at [www.sporlan.com](http://www.sporlan.com), or write Sporlan and request Bulletin 90-30 or Bulletin R-410A.

### Nomenclature/Ordering Instructions

To eliminate shipment delays, specify complete valve designations.

<b>LAC</b>	<b>4</b>	<b>DS</b>	<b>100/180</b>	<b>3/8"</b>	x	<b>3/8"</b>	x	<b>3/8</b>	<b>ODF</b>
Valve Type: Low Ambient Control	Valve Size	Dual Setting Omit for standard dome element	Valve Setting(s) (psig) Specify one setting for standard dome element	Discharge Connection (Inches)		Condenser Connection (Inches)		Receiver Connection (Inches)	Solder Connections
<b>LAC</b>	<b>5</b>	<b>180</b>	<b>R</b>	<b>5/8"</b>	x	<b>5/8"</b>	x	<b>3/8</b>	<b>ODF</b>
Valve Type: Low Ambient Control	Valve Size	Valve Setting(s) (psig)	Indicates Remote Bulb Model Delete for standard dome element	Discharge Connection (Inches)		Condenser Connection (Inches)		Receiver Connection (Inches)	Solder Connections

## ▼ DEFROST DIFFERENTIAL PRESSURE REGULATING VALVES



In many supermarket applications refrigerant gas from the discharge line or from the top of the receiver is used for defrost. This method of defrost diverts a portion of the hot gas or cool gas (from the top of the receiver) to the suction line and back through the evaporator being defrosted. The gas condenses in the evaporator and flows in reverse, through check valves, around the TEV and liquid line solenoid valve. Liquid refrigerant then flows to the liquid header where it is distributed to evaporators not in the defrost cycle. In order for this reverse flow to occur, the pressure of the defrost header must be greater than the pressure of the liquid header. The difference in pressure is known as the defrost differential.

Several methods are used to obtain the defrost differential. A common **liquid line method** is to install a differential check valve in parallel with a solenoid valve between the receiver and the liquid header. When the solenoid valve is closed during defrost, it allows the differential check valve to control the receiver at a greater pressure than the liquid header. Sporlan offers the (O)LDR-16 and (O)LDR-20 versions for this application. The (O)LDR valve combines the features of the liquid differential check valve and the solenoid valve into a single component.

A **discharge line method** is to install a discharge differential pressure regulating valve in the discharge line before the condenser. In order for the reverse flow of hot gas to occur, the pressure of the discharge gas (defrost header) must be greater than the pressure of the receiver (liquid header). Sporlan offers the DDR-20 for this application.

### (O)LDR Valve Operation

The (O)LDR is designed to maintain a differential pressure between the receiver and the liquid header. These valves are available in two port sizes, the (O)LDR-16 (1") and the (O)LDR-20 (1-5/16").

Sporlan liquid line differential valves have a solenoid bypass feature that allows the valve to remain full open or modulate to maintain a differential. We supply two versions of liquid line differential valves:

The **OLDR** is in the **full open position** when the coil is de-energized, and it's in differential operation mode when the coil is energized.

The **LDR** is in **differential operation mode** when the coil is de-energized, and it is in the full open position when the coil is energized.

The **XTM** was identical in operation (no longer available) to the LDR-16, and the **XTO** is identical in operation to the LDR-20. The special feature of the XTM and XTO versions are the special outlet fitting configurations. Different outlet fittings are indicated by a suffix -1, -4 or -5 (i.e. the XTM-1 has connections 1-3/8" ODF x 1-3/8" ODF 90° elbow).

### DDR-20 Valve Operation

The DDR-20 is designed to create a differential pressure between its inlet (discharge) pressure and the receiver pressure.

A solenoid bypass feature is incorporated in the valve so that the valve can be made to go full open when there is no need for a differential to be created. Energizing the solenoid coil opens the valve fully.

### Location and Piping

The (O)LDR valves is located between the receiver and the liquid header. The DDR-20 is located in the discharge line before the condenser. Figure 5 is a piping schematic only to illustrate the general location of the (O)LDR and DDR-20 valves in the system. The two types of defrost differential valves (liquid line and discharge line) are not to be applied on the same system. Sporlan recommends that recognized piping references be consulted for assistance in piping procedures. Sporlan is not responsible for system design, any damage arising from faulty system design, or for misapplication of its products. If these valves are applied in any manner other than as described in this bulletin or other Sporlan literature, the Sporlan warranty is void.

### Adjustment Range and Pressure Settings

All defrost differential valves are set by turning the adjusting stem located under the cap on the pilot differential valve. The adjustment range is 5 to 50 psig. The (O)LDR has a factory setting of 18 psid and the DDR-20 has a factory setting of 30 psid. Turning the stem clockwise increases the setting, counterclockwise decreases the setting.

### Capacities – Tons

Capacities based on 40°F evaporator temperature, 100°F condensing temperature, 25°F superheat return gas, discharge gas temperature 50°F above isentropic compression.

VALVE TYPE	REFRIGERANT																	
	22					134a					404A & 507							
	PRESSURE DROP ACROSS VALVE – psi																	
	.5	1	2	3	4	5	.5	1	2	3	4	5	.5	1	2	3	4	5
LDR-16, OLDR-16	—	33.2	46.9	57.6	66.5	74.3	—	31.0	43.9	53.8	61.2	69.5	—	22.0	31.1	38.1	44.0	49.2
LDR-20, OLDR-20	—	73.4	104	127	147	164	—	68.7	97.1	119	136	154	—	48.6	68.7	84.2	97.3	109
DDR-20	10.3	14.6	20.6	25.1	29.0	32.3	8.57	12.1	17.0	20.8	24.0	26.6	9.35	13.2	18.7	22.8	26.3	29.3



## ▼ EVAPORATOR PRESSURE REGULATING VALVES

The Sporlan line of evaporator pressure regulating (EPR) valves are designed to provide an accurate and economical means of balancing system capacity and load requirements during “low” loads and/or while maintaining different evaporator conditions on multi-temperature evaporator systems. These valves control evaporator temperature by maintaining evaporator pressure. As the evaporator load increases the **ORI** valves will **O**pen on **R**ise of **I**nlet pressure above the valve’s setting to provide more flow capacity to meet the evaporator load. When the evaporator load decreases the valves will modulate closed to maintain the pressure setting of the valve.

Sporlan offers a number of EPR valve types in various sizes, and with optional features to accommodate almost any industry requirement. For more complete information on any of the EPR valve types see your Sporlan Wholesaler or contact your Sporlan Sales Engineer.

### Applications

- Maintain minimum evaporator temperature to avoid frost on air coils and provide improved humidity control
- Evaporator temperature control for food merchandisers (single and multiple evaporator systems)
- Evaporator temperature control on water chilling units

### Required Sizing Information

- Refrigerant type
- Evaporator design capacity
- Design evaporator temperature or minimum evaporator pressure
- Available pressure drop
- Allowable evaporator pressure change (only applies to direct acting models)

### Capacities – Tons

Capacities based on 100°F condensing temperature, 0°F subcooling, 10°F superheat, 8 psi evaporator pressure change for 0/50 psi adjustment range, and a 12 psi evaporator pressure change for 30/100 psi adjustment range. *Vacuum – Inches of Mercury – Italic Figures*

VALVE TYPE	EVAPORATOR TEMPERATURE °F	SATURATED PRESSURE – psig (Reference)				REFRIGERANT											
		REFRIGERANT				PRESSURE DROP ACROSS VALVE – psi											
		22	134a	404A	507	22			134a			404A			507		
		2	5	10	2	5	10	2	5	10	2	5	10	2	5	10	
ORIT-6	40	68.6	35.0	85.7	89.8	1.27	1.90	2.45	0.94	1.35	1.57	1.11	1.67	1.60	1.09	1.65	2.16
	20	43.1	18.4	55.7	58.8	1.02	1.49	1.82	0.72	0.96	1.00	0.87	1.28	2.18	0.86	1.27	1.60
	0	24.0	6.5	33.0	35.2	0.79	1.11	1.22	0.52	0.62	0.62	0.66	0.93	1.07	0.65	0.93	1.09
	-20	10.2	3.6	16.3	17.8	0.60	0.76	0.77	—	—	—	0.48	0.64	0.66	0.48	0.64	0.67
ORIT-10	40	68.6	35.0	85.7	89.8	3.13	4.91	6.84	2.39	3.73	5.13	2.73	4.28	5.98	2.68	4.21	5.88
	20	43.1	18.4	55.7	58.8	2.55	3.99	5.52	1.87	2.89	3.93	2.16	3.38	4.69	2.13	3.33	4.63
	0	24.0	6.5	33.0	35.2	2.04	3.17	4.34	1.43	2.18	2.88	1.67	2.61	3.58	1.66	2.58	3.55
	-20	10.2	3.6	16.3	17.8	1.59	2.45	3.29	—	—	—	1.27	1.95	2.64	1.26	1.94	2.63

### Installation

When installing ORIT’s with solder connections, the internal parts should be protected by wrapping the valve with a wet cloth.

### ORIT – Valve Nomenclature/Ordering Instructions

<b>ORI</b>	<b>T</b>	<b>6</b>	<b>0/50</b>	<b>7/8” ODF</b>
Valve Type: Open on Rise of Inlet Pressure	Pressure Tap on Inlet Connection	Port Size in Eighths of an Inch	Adjustment Range – psig*	Connection ODF Solder or SAE Flare

\* Other pressure ranges are available.

For complete information see your Sporlan Wholesaler, our website at [www.sporlan.com](http://www.sporlan.com), or write Sporlan and request Bulletin 90-20.

### ORIT-6 and -10 Features

- Direct acting (most economical)
- Adjustable
- Hermetic construction (no gaskets or seals)
- Corrosion resistant construction
- Inlet pressure tap (standard)
- Inlet strainer (standard on ODF models)

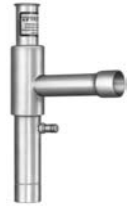

These direct acting EPRs are offered in two sizes. The direct acting design although economical requires an evaporator pressure change above the minimum evaporator pressure setting to provide the rated flow capacity. The nominal ratings are based on an 8 psi evaporator pressure change for the 0/50 psi adjustment range, and a 12 psi change for the 30/100 range. Valves should be selected for the desired maximum variation in evaporator pressure using the capacity multipliers below.

ALLOWABLE EVAPORATOR PRESSURE CHANGE – psi		2	4	6	8	10	12	14
CAPACITY MULTIPLIER	ORIT-6, 10-0/50	.3	.6	.8	1.0	1.2	1.3	1.4
	ORIT-6, 10-30/100	—	.2	.6	.7	.9	1.0	1.1

### Specifications

VALVE TYPE	PORT SIZE Inches	ADJUSTMENT RANGE	STANDARD CONNECTIONS In BOLD
ORIT-6	.75	0/50 or 30/100	1/2 & 5/8 SAE Flare* 1/2, 5/8, <b>7/8</b> & 1-1/8 ODF Solder
ORIT-10	1.218		<b>7/8, 1-1/8 &amp; 1-3/8</b> ODF Solder

\*Not available with inlet strainer.

# ▼ EVAPORATOR PRESSURE REGULATING VALVES

## (S)ORIT-12, -15 and -20 Features

- High side pilot for improved temperature control and low ΔP operation
- Adjustable
- Optional solenoid “stop” feature to close valve during defrost
- Normally open design allows system evacuation without manual operator

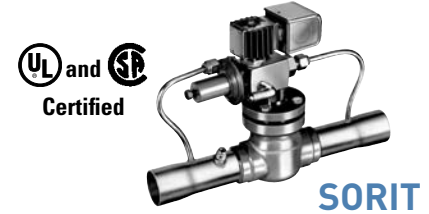

These EPRs are pilot operated using “high side” pressure and require a pilot supply connection from the compressor discharge to operate. They are designed to be “normally open” providing an unparalleled ability to operate with virtually no suction line pressure drop. The pilot operated design does not require the “allowable evaporator pressure change” necessary with the direct acting models, and can be simply sized based on design evaporator temperature and available pressure drop across the valve at full load conditions.

## Specifications

VALVE TYPE	PORT SIZE Inches	ADJUSTMENT RANGE psig	STANDARD COIL RATINGS *MKC-1		CONNECTIONS ODF SOLDER Inches
			VOLTS/CYCLES	WATTS	
(S)ORIT-12	25/32	0/100	24/50-60	10	1-1/8
(S)ORIT-15	1		120/50-60		1-3/8
(S)ORIT-20	1-5/16		208-240/50-60 120-208-240/50-60		1-5/8

\*Available with junction box or conduit boss at no extra charge. For voltage other than listed consult Bulletin 30-10.

## Capacities – Tons

Capacities based on 60°F condensing temperature, 0°F superheat at the evaporator, and 25°F superheat at the valve.

VALVE TYPE	EVAPORATOR TEMPERATURE °F	REFRIGERANT															
		22				134a				404A				507			
		PRESSURE DROP ACROSS VALVE – psi															
		0.5	2	5	10	0.5	2	5	10	0.5	2	5	10	0.5	2	5	10
(S)ORIT-12	40	2.30	4.56	7.13	9.89	1.83	3.62	5.59	7.62	2.22	4.42	6.92	9.61	2.15	4.28	6.70	9.32
	20	1.88	3.74	5.80	7.97	1.45	2.85	4.35	5.80	1.79	3.55	5.53	7.62	1.74	3.45	5.37	7.41
	0	1.52	3.00	4.62	6.23	1.12	2.19	3.27	4.20	1.41	2.79	4.32	5.87	1.38	2.72	4.21	5.74
	-20	1.20	2.35	3.56	4.67	—	—	—	—	1.09	2.15	3.27	4.34	1.07	2.10	3.20	4.27
(S)ORIT-15	40	3.86	7.67	12.0	16.6	3.07	6.07	9.38	12.7	3.73	7.43	11.6	16.1	3.61	7.19	11.3	15.6
	20	3.17	6.27	9.74	13.3	2.43	4.78	7.29	9.68	3.00	5.96	9.27	12.8	2.92	5.79	9.01	12.4
	0	2.55	5.03	7.73	10.4	1.88	3.67	5.47	6.97	2.37	4.69	7.24	9.81	2.31	4.57	7.06	9.59
	-20	2.01	3.94	5.95	7.77	—	—	—	—	1.83	3.60	5.48	7.24	1.79	3.52	5.36	7.11
(S)ORIT-20	40	8.33	16.5	25.7	35.5	6.63	13.1	20.1	27.0	8.06	16.0	25.0	34.5	7.80	15.5	24.2	33.5
	20	6.83	13.5	20.9	28.4	5.24	10.3	15.5	20.3	6.49	12.8	19.9	27.2	6.30	12.5	19.4	26.5
	0	5.50	10.8	16.5	22.0	4.06	7.85	11.6	14.4	5.12	10.1	15.5	20.8	4.99	9.84	15.1	20.4
	-20	4.34	8.45	12.6	16.2	—	—	—	—	3.96	7.74	11.7	15.2	3.86	7.56	11.4	15.0

## Refrigerant Liquid Temperature Correction Factors

REFRIGERANT	LIQUID TEMPERATURE ENTERING VALVE °F										
	0°	10°	20°	30°	40°	50°	60°	70°	80°	90°	100°
	CORRECTION FACTOR, CF LIQUID TEMPERATURE										
R-22	1.22	1.18	1.15	1.11	1.07	1.04	1.00	0.96	0.92	0.88	0.84
R-134a	1.26	1.22	1.18	1.14	1.09	1.05	1.00	0.95	0.90	0.86	0.81
R-404A	1.33	1.28	1.23	1.17	1.12	1.06	1.00	0.94	0.88	0.81	0.74
R-507	1.34	1.29	1.23	1.17	1.12	1.06	1.00	0.94	0.88	0.82	0.75

\*ARI standard capacities are based on 100°F saturated liquid temperature. Use the correction factor for 100°F liquid temperature and the capacities at 40°F evaporator temperature to determine ARI standard capacity ratings.

Example: The capacity of a (S)ORIT-12 using R-22, evaporator temperature of 20°F, 2 psi pressure drop across the valve and a liquid temperature of 50°F, is equal to (3.74 x 1.04) 3.9 tons.

These factors correct for net refrigerating effect and are based on an average temperature of 0°F. However, they may be used for any evaporator temperature from -35°F to 40°F since the variation in the actual factors across this range is insignificant.

## Installation

When installing these valves with solder connections, the internal parts should be protected from overheating by wrapping the valve with a wet cloth.

## Nomenclature/Ordering Instructions

<b>S</b>	<b>ORI</b>	<b>T</b>	<b>15</b>	<b>0/100</b>	<b>1-3/8" ODF</b>	<b>120/50-60</b>
Solenoid Stop Feature (optional)	Valve Type: Open on Rise of Inlet Pressure	Pressure Tap on Inlet Connection	Valve Size	Adjustment Range – psig*	Connections ODF Solder	Electrical Specifications for Solenoid Stop Feature (optional)

\* Other pressure ranges are available.

For complete information see your Sporlan Wholesaler, our website at [www.sporlan.com](http://www.sporlan.com), or write Sporlan and request Bulletin 90-20.

# ▼ EVAPORATOR PRESSURE REGULATING VALVES

## (S)ORIT-PI-2, -3, -4 and -5 Features

- Piloted internally (No high side connection required)
- Superior corrosion resistance
- Optional solenoid “stop” feature to close valve during defrost
- Optional electric open feature for “two temperature operation”
- Manual lift stem (standard) to allow system evacuation

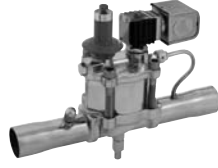

**SORIT-PI**

valve to become adaptable for application updates or refrigerant conversions. Please contact Sporlan or ask your Sporlan Wholesaler for an “SK-PI series kit. Along with these design improvements it is now necessary to change both the pilot assembly and internal piston together during service. “RK-(S)ORIT-PI” kits have been established for replacement of either of these components.

## Specifications

VALVE TYPE	PORT SIZE Inches	ADJUSTMENT RANGE psig	STANDARD COIL RATINGS *MKC-1		CONNECTIONS ODF SOLDER Inches
			VOLTS/CYCLES	WATTS	
(S)ORIT-PI-2	1/2	0/100 or 75/150	24/50-60 120/50-60 208-240/50-60 120-208-240/50-60	10	5/8, 7/8, 1-1/8, 1-3/8
(S)ORIT-PI-3	3/4				7/8, 1-1/8, 1-3/8, 1-5/8
(S)ORIT-PI-4	1				1-1/8, 1-3/8, 1-5/8
(S)ORIT-PI-5	1-1/4				1-5/8, 2-1/8

\*Available with junction box or conduit boss at no extra charge. For voltage other than listed consult Bulletin 30-10.

These EPRs are Piloted Internally using the natural pressure drop across the valve to operate and do not require a “high side” pilot connection. And, like the (S)ORIT valves, the pilot operated design does not require the “allowable evaporator pressure change” necessary with the direct acting models, and can be simply sized based on design evaporator temperature and available pressure drop across the valve at full load conditions.

Design improvements to the SORIT-PI family of valves has resulted in removable ports so that components can now be exchanged to increase or decrease valve capacity. This unique feature allows the

## Capacities – Tons

Capacities based on 60°F condensing temperature, 10°F superheat at the evaporator, and 0°F superheat at the valve.

VALVE TYPE	EVAPORATOR TEMPERATURE °F	REFRIGERANT															
		22				134a				404A				507			
		PRESSURE DROP ACROSS VALVE – psi															
		1	2	5	10	1	2	5	10	1	2	5	10	1	2.5	5	10
(S)ORIT-PI-2	40	2.46	3.41	5.25	7.78	1.99	2.75	4.41	5.83	2.36	3.27	5.03	7.59	2.28	3.16	4.86	7.37
	20	2.05	2.83	4.36	6.18	1.59	2.21	3.38	4.29	1.92	2.66	4.10	5.94	1.86	2.58	3.97	5.79
	0	1.67	2.31	3.62	4.71	1.26	1.73	2.47	2.90	1.54	2.13	3.40	4.48	1.49	2.07	3.32	4.39
	-20	1.34	1.85	2.73	3.35	—	—	—	—	1.21	1.67	2.53	3.19	1.17	1.63	2.49	3.15
(S)ORIT-PI-3	40	4.37	6.10	9.47	13.7	3.51	4.90	7.74	10.3	4.20	5.86	9.10	13.3	4.06	5.67	8.80	12.9
	20	3.62	5.05	7.83	10.9	2.81	3.92	5.96	7.67	3.41	4.75	7.38	10.5	3.30	4.61	7.15	10.2
	0	2.94	4.10	6.36	8.37	2.20	3.03	4.40	5.29	2.72	3.79	5.97	7.93	2.64	3.68	5.83	7.77
	-20	2.35	3.26	4.83	6.05	—	—	—	—	2.12	2.96	4.47	5.71	2.07	2.88	4.38	5.64
(S)ORIT-PI-4	40	6.58	9.25	14.5	21.2	5.27	7.40	12.0	16.1	6.35	8.92	14.0	20.7	6.15	8.63	13.5	20.1
	20	5.43	7.62	11.9	17.0	4.20	5.89	9.29	12.1	5.13	7.21	11.3	16.3	4.98	6.99	11.0	15.9
	0	4.40	6.18	9.89	13.1	3.28	4.70	6.89	8.44	4.07	5.72	9.28	12.4	3.96	5.57	9.06	12.1
	-20	3.49	4.90	7.55	9.58	—	—	—	—	3.17	4.45	6.97	9.00	3.09	4.34	6.83	8.87
(S)ORIT-PI-5	40	8.23	11.6	18.1	25.1	6.54	9.19	14.2	19.4	7.97	11.2	17.6	24.5	7.71	10.9	17.0	23.7
	20	6.75	9.49	14.8	20.3	5.17	7.24	11.1	14.8	6.41	9.02	14.1	19.4	6.22	8.76	13.7	18.9
	0	5.43	7.62	11.7	15.9	4.00	5.56	8.35	10.8	5.06	7.10	11.0	15.0	4.92	6.91	10.7	14.6
	-20	4.28	5.97	9.06	11.9	—	—	—	—	3.90	5.46	8.33	11.1	3.81	5.33	8.15	10.9

## Refrigerant Liquid Temperature Correction Factors

REFRIGERANT	LIQUID TEMPERATURE ENTERING VALVE °F										
	0°	10°	20°	30°	40°	50°	60°	70°	80°	90°	100°
CORRECTION FACTOR, CF LIQUID TEMPERATURE											
R-22	1.22	1.18	1.15	1.11	1.07	1.04	1.00	0.96	0.92	0.88	0.84
R-134a	1.26	1.22	1.18	1.14	1.09	1.05	1.00	0.95	0.90	0.86	0.81
R-404A	1.33	1.28	1.23	1.17	1.12	1.06	1.00	0.94	0.88	0.81	0.74
R-507	1.34	1.29	1.23	1.17	1.12	1.06	1.00	0.94	0.88	0.82	0.75

\*ARI standard capacities are based on 100°F saturated liquid temperature. Use the correction factor for 100°F liquid temperature and the capacities at 40°F evaporator temperature to determine ARI standard capacity ratings.

Example: The capacity of a (S)ORIT-PI-3 using R-22, evaporator temperature of 20°F, 2 psi pressure drop across the valve and a liquid temperature of 50°F, is equal to (5.05 x 1.04) 5.3 tons.

These factors correct for net refrigerating effect and are based on an average temperature of 0°F. However, they may be used for any evaporator temperature from -35°F to 40°F since the variation in the actual factors across this range is insignificant.

## Installation

When installing these valves with solder connections, the internal parts should be protected from overheating by wrapping the valve with a wet cloth.

## Nomenclature/Ordering Instructions

<b>S</b>	<b>ORI</b>	<b>T</b>	<b>PI</b>	<b>2</b>	<b>7</b>	<b>S</b>	<b>E</b>	<b>0/100</b>	<b>120/50-60</b>
Solenoid Stop Feature (optional)	Valve Type: Open on Rise of Inlet Pressure	Pressure Tap on Inlet Connection	Piloted Internally	Port Size in 1/4 of an Inch	Fitting Size in 1/8 of an Inch	Solenoid Stop Feature (optional)	Electric Open Feature (optional)	Adjustment range psig*	Electrical specifications for Solenoid Stop Feature (optional)

\* Other pressure ranges are available.

# ▼ ELECTRONIC TEMPERATURE CONTROL SYSTEMS

ELECTRIC EXPANSION VALVES



Sporlan Electric Expansion Valves (EEVs) are currently available in nominal R-22 capacities from 1/2 to 175 tons (1.76 to 615 kW). Therefore, they are applicable on all the same types of systems found in the air conditioning and refrigeration industry as thermostatic expansion valves.

The ESX, SER, SEI and SEH are Electronically Operated Step Motor flow control valves, intended for the precise control of liquid refrigerant flow. Synchronized signals to the motor provide discrete angular movement, which translates into precise linear positioning of the valve piston. Valve pistons and ports are uniquely characterized, providing improved flow resolution and performance. The ESX, SER, SEI and SEH valves are easily interfaced with microprocessor based controllers, including Sporlan supplied controllers.

All Sporlan electric valves are designed for compatibility with all current halocarbon refrigerants, including CFCs, HCFCs and HFCs and R-410A. Specific system conditions will dictate which product is necessary to control the application. Details can be reviewed with the Sporlan Sales Engineer.

## Specifications

TYPE	INLET – Inches	OUTLET – Inches	CONFIGURATION	CABLE LENGTH
ESX 14	5/16 ODF, 3/8 ODF	5/16 ODF, 3/8 ODF, 1/2 ODF	Angle	5', 10'
ESX 18	5/16 ODF, 3/8 ODF	5/16 ODF, 3/8 ODF, 1/2 ODF	Angle	5', 10'
ESX 24	5/16 ODF, 3/8 ODF	5/16 ODF, 3/8 ODF, 1/2 ODF	Angle	5', 10'
SER 1.5	3/8, 1/2, 5/8 ODF	3/8, 1/2, 5/8	Angle	10', 40'
SER 6	3/8, 1/2, 5/8 ODF	3/8, 1/2, 5/8, 7/8	Angle	10', 40'
SER 11	3/8, 1/2, 5/8 ODF	1/2, 5/8, 7/8, 1-1/8 ODF	Angle	10', 40'
SER 20	1/2, 5/8, 7/8, 1-1/8 ODF	5/8, 7/8, 1-1/8, 1-3/8 ODF	Angle	10', 40'
SER G	5/8 ODF	7/8 ODF	Angle	10'
SER J	7/8 ODF	7/8 ODF	Angle	10'
SER K	1-1/8 ODF	1-1/8 ODF	Angle	10'
SEI 30	5/8, 7/8, 1-1/8 ODF	5/8, 7/8, 1-1/8, 1-3/8 ODF	Angle	10', 20', 30', 40'
SEI 50	7/8, 1-1/8, 1-3/8 ODF	7/8, 1-1/8, 1-3/8, 1-5/8 ODF	Straight through	10', 20', 30', 40'
SEH 100	1-1/8, 1-3/8 ODF	1-3/8, 1-5/8 ODF	Straight through	10', 20', 30', 40'
SEH 175	1-1/8, 1-3/8, 1-5/8 ODF	2-1/8 ODF	Straight through	10', 20', 30', 40'

VALVE TYPE	CAPACITY – TONS														
	R-22			R-134a			R-404A			R-407C			R-410A		
	40°F	20°F	0°F	40°F	20°F	0°F	40°F	20°F	0°F	40°F	20°F	0°F	40°F	20°F	0°F
ESX 14	1.3	1.4	1.4	1.0	1.1	1.0	0.9	0.9	0.9	2.0	1.3	1.2	1.6	1.4	1.7
ESX 18	2.3	2.4	2.4	1.6	1.8	1.7	1.5	1.6	1.5	3.3	2.2	2.1	2.7	3.0	2.9
ESX 24	4.6	5.0	4.9	3.4	3.7	3.5	3.1	3.2	3.1	6.9	4.4	4.2	5.6	4.7	5.9
SER 1.5	1.5	1.6	1.6	1.1	1.2	1.1	1.0	1.1	1.0	1.4	1.5	1.4	1.8	2.0	1.9
SER 6	6.0	6.5	6.4	4.3	4.8	4.5	4.0	4.2	4.0	5.5	5.9	5.7	7.0	7.8	7.6
SER 11	11.0	12.0	11.6	7.9	8.8	8.3	7.3	7.7	7.3	10.1	10.9	10.4	12.8	14.4	14.0
SER 20	20.0	21.8	21.2	14.4	15.9	15.2	13.2	14.0	13.2	18.4	19.7	18.8	23.2	26.1	25.4
SER G	22.6	24.6	23.9	16.3	18.0	17.1	15.5	16.7	15.8	20.7	22.3	21.3	27.0	29.5	28.7
SER J	40.6	44.3	43.0	29.3	32.4	30.8	27.0	29.0	27.5	37.3	40.1	38.3	48.7	53.1	51.6
SER K	73.6	80.3	78.0	53.2	58.7	55.8	48.0	51.0	49.0	67.7	72.6	69.3	88.2	96.3	93.5
SEI 30	35.0	33.1	37.1	25.3	27.9	26.5	23.1	24.5	23.1	32.2	34.5	33.0	41.9	45.8	44.4
SEI 50	49.8	54.3	52.7	36.0	39.7	37.7	32.9	34.9	32.8	45.8	49.1	46.9	57.8	65.1	63.2
SEH 100	100.0	109.0	105.0	72.2	79.6	75.8	66.1	70.1	65.9	92.0	98.6	94.2	116.0	131.0	127.0
SEH 175	174.0	190.0	184.0	126.0	139.0	132.0	115.0	122.0	115.0	160.0	172.0	164.0	202.0	227.0	221.0

## ESX – Nomenclature/Ordering Instructions

<b>ESX</b>	<b>-14</b>	<b>B</b>	<b>5</b>	<b>S</b>
Valve Model	Orifice Diameter 14 = 1.4 mm 18 = 1.8 mm 24 = 2.4 mm	Connections 5/16 x 5/16 ODF A 3/8 x 3/8 ODF B 3/8 x 1/2 ODF	Cable Length 5' & 10' available	Stripped and Tinned ends

## SEI, SEH(I) or SER(I) – Nomenclature/Ordering Instructions

<b>SEH</b>	<b>(I)</b>	<b>175</b>	<b>1-1/8"</b> x	<b>2-1/8"</b>	<b>ODF</b>	<b>10</b>	<b>S</b>
Valve Model	Indicating Sightglass optional (not available on small SER, SEI)	Valve Nominal Capacity	Inlet Fitting 7/8", 1-3/8" and 1-5/8" available*	Outlet Fitting 1-3/8", 1-5/8" and 2-1/8" available*	Fitting type ODF only	Cable Length 10' standard, 30' and 40' available	Stripped and Tinned cable ends, Packard Weather PAK™ also available

\* Not all fitting sizes are available on all valves.

# ▼ ELECTRONIC TEMPERATURE CONTROL SYSTEMS

ELECTRIC EVAPORATOR CONTROL VALVE

## CDS-4, -7, -9, -16 and -17

The CDS family of valves provide precise temperature or pressure control of refrigeration evaporators. Designed for low pressure drop, the CDS valves provide energy savings due to their ability to shorten pulldown time after defrost to one half or less than mechanical EPR valves. The extremely stable control helps compressor life by minimizing changes in suction pressure that elad to short or excessive cycling of the compressor.

Temperature stability of  $\pm 0.5^{\circ}\text{F}$  (0.25K) prolongs product life and reduces shrinkage in sensitive products.

Controllers used with the CDS valves permit remote monitoring and setting as well as simple changeover for two temperature cases. The range of sizes guarantees the correct valve for any capacity, from less than .5 tons to over 35 tons depending on refrigerant and conditions.

### Specifications

(Standard Connections and Cable Lengths are in <b>BOLD</b> type.)					
TYPE	STEPS	CONNECTIONS ODF SOLDER – Inches	CONFIGURATION	CABLE LENGTH Feet	CABLE ENDS
CDS-4	2500	1/2, 5/8, 7/8	Straight Through	<b>10</b>	<b>S</b> -Stripped and Tinned
CDS-7		5/8, 7/8, 1-1/8, 1-3/8	Straight Through	<b>10</b>	<b>S</b> -Stripped and Tinned
CDS-9	6386	5/8, 7/8, 1-1/8, 1-3/8	Angle or Straight Through	<b>10</b>	<b>S</b> -Stripped and Tinned
CDS-16		1-3/8	Angle	<b>10</b>	<b>S</b> -Stripped and Tinned
CDS-17		1-3/8, 1-5/8, 2-1/8	Straight Through	<b>10</b>	<b>S</b> -Stripped and Tinned

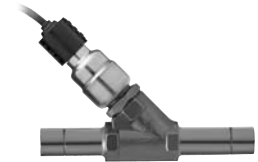

### Suction Capacities – Tons

VAVLE TYPE	EVAPORATOR TEMPERATURE (°F)	REFRIGERANT																		
		22					422D					404A/507								
		PRESSURE DROP ACROSS VALVE (PSI)																		
		0.5	1	2	3	5	10	0.5	1	2	3	5	10	0.5	1	2	3	5	10	
2500 STEPS	CDS-4	40	1.10	1.54	2.16	2.64	3.39	4.77	0.91	1.28	1.79	2.19	2.81	3.94	1.02	1.44	2.02	2.46	3.16	4.51
		30	1.00	1.40	1.97	2.40	3.08	4.28	0.82	1.14	1.61	1.96	2.51	3.47	0.92	1.30	1.82	2.22	2.85	4.02
		20	0.91	1.27	1.78	2.17	2.79	3.82	0.73	1.02	1.43	1.75	2.25	3.03	0.83	1.16	1.64	1.99	2.56	3.57
		10	0.82	1.15	1.61	1.96	2.51	3.37	0.64	0.90	1.27	1.55	1.97	2.62	0.74	1.04	1.46	1.78	2.29	3.13
		0	0.73	1.03	1.45	1.76	2.22	2.94	0.57	0.80	1.12	1.36	1.71	2.24	0.66	0.93	1.30	1.59	2.04	2.73
		-10	0.66	0.92	1.29	1.56	1.95	2.54	0.50	0.70	0.98	1.18	1.47	1.87	0.59	0.82	1.15	1.41	1.78	2.35
		-20	0.58	0.82	1.14	1.37	1.7	2.15	0.43	0.61	0.84	1.01	1.24	1.53	0.52	0.72	1.02	1.23	1.54	1.99
	-30	0.52	0.72	0.994	1.19	1.45	1.77	0.38	0.52	0.72	0.85	1.03	1.21	0.45	0.63	0.88	1.06	1.31	1.65	
	CDS-7	40	3.12	4.31	5.96	7.21	9.16	13.0	2.57	3.56	4.92	5.95	7.56	10.7	2.88	3.99	5.52	6.67	8.47	12.4
		30	2.85	3.94	5.45	6.58	8.36	11.6	2.31	3.20	4.42	5.35	6.79	9.33	2.61	3.61	4.99	6.04	7.67	11.0
		20	2.59	3.58	4.95	5.99	7.61	10.2	2.07	2.86	3.96	4.78	6.17	8.05	2.35	3.26	4.50	5.44	6.92	9.63
		10	2.34	3.24	4.49	5.42	6.87	8.89	1.84	2.55	3.52	4.26	5.36	6.84	2.11	2.92	4.04	4.89	6.21	8.37
		0	2.09	2.93	4.05	4.87	6.03	7.62	1.62	2.26	3.12	3.74	4.60	5.70	1.89	2.61	3.61	4.37	5.56	7.19
		-10	1.86	2.60	3.59	4.28	5.24	6.40	1.41	1.97	2.70	3.21	3.90	4.61	1.67	2.32	3.21	3.89	4.82	6.07
-20		1.64	2.29	3.14	3.72	4.48	5.21	1.22	1.70	2.31	2.72	3.23	3.59	1.47	2.05	2.82	3.37	4.12	5.01	
-30	1.44	2.00	2.72	3.19	3.76	4.09	1.05	1.45	1.95	2.27	2.61	2.72	1.27	1.77	2.43	2.88	3.46	3.99		
6386 STEPS	CDS-9	40	4.64	6.45	8.96	10.9	13.8	19.7	3.84	5.33	7.41	8.98	11.4	16.3	4.31	5.98	8.31	10.1	12.8	18.6
		30	4.24	5.88	8.18	9.91	12.6	17.6	3.45	4.79	6.65	8.06	10.3	14.3	3.89	5.41	7.52	9.11	11.6	16.6
		20	3.83	5.35	7.43	9.00	11.5	15.7	3.08	4.28	5.94	7.20	9.30	12.5	3.51	4.87	6.77	8.21	10.5	14.7
		10	3.45	4.84	6.72	8.15	10.4	13.8	2.72	3.80	5.28	6.41	8.13	10.7	3.15	4.37	6.07	7.36	9.38	12.9
		0	3.08	4.33	6.05	7.30	9.17	12.1	2.39	3.35	4.67	5.63	7.03	9.13	2.79	3.90	5.42	6.57	8.40	11.2
		-10	2.75	3.85	5.35	6.45	8.04	10.3	2.09	2.92	4.05	4.86	6.02	7.61	2.47	3.46	4.82	5.84	7.32	9.61
		-20	2.43	3.40	4.71	5.64	6.96	8.71	1.81	2.52	3.48	4.15	5.08	6.18	2.16	3.03	4.22	5.07	6.32	8.11
	-30	2.14	2.98	4.10	4.88	5.94	7.13	1.55	2.16	2.96	3.50	4.20	4.83	1.88	2.63	3.64	4.36	5.38	6.70	
	CDS-16	40	7.72	10.7	14.7	17.8	22.6	31.9	6.37	8.80	12.2	14.7	18.7	26.2	7.14	9.86	13.6	16.5	20.9	30.3
		30	7.05	9.74	13.5	16.3	20.7	28.3	5.73	7.91	10.9	13.2	16.8	22.8	6.46	8.93	12.3	14.9	18.9	26.9
		20	6.41	8.87	12.3	14.8	18.8	24.9	5.12	7.08	9.79	11.8	15.2	19.6	5.83	8.06	11.1	13.5	17.1	23.6
		10	5.77	8.03	11.1	13.4	16.9	21.7	4.55	6.31	8.72	10.5	13.1	16.6	5.24	7.24	10.0	12.1	15.3	20.5
		0	5.16	7.22	10.0	12.0	14.8	18.5	4.00	5.58	7.70	9.20	11.3	13.8	4.68	6.47	8.94	10.8	13.7	17.5
		-10	4.59	6.41	8.82	10.5	12.8	15.4	3.48	4.85	6.65	7.88	9.50	11.1	4.13	5.75	7.95	9.57	11.8	14.7
-20		4.06	5.64	7.71	9.12	10.9	12.5	3.01	4.18	5.68	6.66	7.86	8.55	3.62	5.05	6.94	8.27	10.1	12.1	
-30	3.56	4.93	6.67	7.80	9.12	9.74	2.59	3.56	4.78	5.53	6.31	6.49	3.14	4.37	5.97	7.05	8.43	9.53		
CDS-17	40	8.30	11.6	16.1	19.5	24.9	35.6	6.87	9.56	13.3	16.1	20.6	29.3	7.71	10.7	14.9	18.1	23.1	33.7	
	30	7.57	10.5	14.7	17.8	22.7	31.8	6.16	8.57	11.9	14.5	18.5	25.8	6.97	9.69	13.5	16.4	20.9	30.0	
	20	6.87	9.57	13.3	16.2	20.6	28.3	5.50	7.66	10.7	12.9	16.8	22.4	6.27	8.73	12.1	14.7	18.8	26.5	
	10	6.22	8.65	12.0	14.6	18.7	24.9	4.89	6.81	9.47	11.5	14.7	19.3	5.62	7.83	10.9	13.2	16.9	23.2	
	0	5.60	7.79	10.8	13.2	16.6	21.6	4.32	6.02	8.37	10.2	12.7	16.3	5.02	6.98	9.72	11.8	15.2	20.1	
	-10	4.98	6.98	9.70	11.7	14.5	18.5	3.78	5.29	7.33	8.78	10.8	13.5	4.45	6.20	8.63	10.5	13.2	17.2	
	-20	4.41	6.16	8.52	10.2	12.5	15.5	3.28	4.57	6.29	7.49	9.11	10.9	3.92	5.47	7.61	9.17	11.4	14.5	
-30	3.87	5.40	7.41	8.80	10.7	12.6	2.82	3.91	5.34	6.30	7.51	8.44	3.42	4.77	6.59	7.88	9.67	11.9		

### Nomenclature/Ordering Instructions

The CDS-16 is the only angled valve. The CDS-4, CDS-7, CDS-9 and CDS-17 are straight through valves.

<b>CDS</b>	<b>T</b>	<b>17</b>	<b>1-3/8 x 1-3/8 ODF</b>	<b>20</b>	<b>S</b>	<b>Angle</b>
Controls Discharge Stepmotor	Optional Inlet Pressure Tap	Model Number	Fitting Size	Cable Length 20' standard, others available	S = Stripped and tinned cable ends. Custom Connectors available	Used only if angled configuration CDS-16 Only

For complete information see your Sporlan Wholesaler, our website at [www.sporlan.com](http://www.sporlan.com), or write Sporlan and request Bulletin 100-60.

# ▼ ELECTRONIC TEMPERATURE CONTROL SYSTEMS

ELECTRIC DISCHARGE BYPASS VALVES

## SDR-3, -3X and -4

SDR series valves are Step Discharge Regulators, or electrically operated discharge gas bypass valves. Unlike previous mechanical discharge gas bypass valves that only control a downstream pressure, the SDR series offers direct temperature control of air or liquid. The valves use the same 12 DC bipolar step motor as all other Sporlan step motor operated valves, including the CDS valves (see page 65). Balanced pistons and ports, uniquely characterized for hot gas flow, have been incorporated into the design. Seating materials, motors and gears have all been laboratory and field proven in high temperature gas applications.

With capacities up to 25 nominal R-22 tons, the SDR series is suitable for use in small process chillers and environmental chambers, as well as large direct expansion air conditioning applications. The valves may be controlled by third party controllers or by the Sporlan TCB interface/controller (see page 69). SDR valves are normally installed in the same manner as mechanical discharge gas bypass valves; in a bypass branch of the discharge gas line. The valves may be piped to feed into the evaporator at the distributor, downstream of the evaporator, or at the compressor suction. Contact Sporlan for additional

pipng recommendations. When applied with a third party controller or DDC building management system, the SDR can be used with the IB or TCB as an interface to the existing system. For stand-alone control, the SDR and TCB with sensor will allow close temperature control of the air or liquid stream. See page 69 for information on the TCB and IB.

The SDR valves are tight seating and will act as solenoid valves for shut off.

## Specifications

TYPE	CONNECTIONS Inches	CONFIGURATION	CABLE LENGTH Feet	CABLE ENDS
SDR-3	3/8, 1/2, 5/8 ODF	Angle	10, 20, 30, 40	S-Stripped and Tinned
SDR-3X	3/8, 1/2, 5/8 ODF	Angle	10, 20, 30, 40	S-Stripped and Tinned
SDR-4	7/8, 1-1/8 ODF	Straight through	10, 20, 30, 40	S-Stripped and Tinned

## Discharge Bypass Valve Capacities – Tons

REFRIGERANT	VALVE TYPE	MINIMUM ALLOWABLE EVAPORATOR TEMPERATURE AT REDUCED LOAD °F																	
		40°F			26°F			20°F			0°F			-20°F			-40°F		
		CONDENSING TEMPERATURE °F																	
		80	100	120	80	100	120	80	100	120	80	100	120	80	100	120	80	100	120
22	SDR-3	5.4	6.9	8.7	5.4	6.7	8.3	5.3	6.7	8.1	4.9	6.2	7.6	4.6	5.8	7.1	4.3	5.5	6.8
	SDR-3X	9.8	12.6	15.9	9.9	12.7	16.0	9.9	12.7	16.0	10.0	12.8	16.2	10.1	13.0	16.4	10.2	13.2	16.6
	SDR-4	17.9	25.2	34.8	19.4	26.4	35.8	19.8	28.0	36.2	20.9	28.1	37.0	21.6	28.7	37.5	22.0	29.8	37.8
134a	SDR-3	3.8	4.7	5.5	3.6	4.4	5.2	3.5	4.2	5.1	3.1	3.8	4.7	2.8	3.5	4.4	2.6	3.3	4.2
	SDR-3X	6.5	8.6	11.1	6.5	8.6	11.1	6.6	8.7	11.1	6.6	8.7	11.2	6.6	8.8	11.3	6.7	8.9	11.4
	SDR-4	13.3	18.4	23.8	14.2	19.1	24.4	14.5	19.3	24.6	15.2	19.9	25.0	15.6	20.2	25.3	15.8	20.4	25.5
404/507	SDR-3	6.0	7.3	8.6	6.3	7.4	8.5	6.1	7.2	8.4	5.6	6.7	7.9	5.0	6.0	7.5	4.8	5.8	7.2
	SDR-3X	10.7	13.5	16.6	10.8	13.6	16.6	10.8	13.6	16.6	10.8	13.6	16.7	10.9	13.7	16.8	11.0	13.8	17.0
	SDR-4	19.9	26.2	31.8	23.1	29.7	35.9	23.7	30.1	36.2	25.0	31.2	37.0	24.3	29.8	35.0	26.6	32.8	38.8
407C	SDR-3	5.4	6.6	8.2	5.2	6.6	7.8	5.1	6.2	7.7	4.7	5.8	7.2	4.3	5.4	6.8	4.0	5.1	6.5
	SDR-3X	9.8	12.9	16.4	9.9	12.9	16.5	9.9	13.0	16.5	10.1	13.1	19.7	10.1	13.2	16.9	10.2	13.4	17.2
	SDR-4	18.3	25.0	34.1	19.8	27.8	35.0	20.3	27.5	35.6	21.6	27.8	36.7	22.4	28.6	37.7	23.0	29.3	38.6
410A	SDR-3	9.1	11.3	13.6	9.1	11.3	13.6	9.1	11.3	13.6	9.1	11.3	13.6	9.1	11.3	12.0	—	—	—
	SDR-3X	16.3	20.3	24.5	16.4	20.3	24.5	16.4	20.3	24.5	16.4	20.3	24.5	16.4	20.3	54.0	—	—	—
	SDR-4	29.7	39.9	49.7	32.3	41.8	51.2	33.1	42.5	51.8	35.0	44.0	53.1	36.1	45.0	13.6	—	—	—

**Note:** Capacities are based on discharge temperature 50°F above isentropic compression, 100°F condensing temperature, 0°F subcooling, 25°F superheat at the compressor and includes both the hot gas bypassed and the liquid refrigerant for desuperheating, regardless of whether the liquid is fed through the system thermostatic expansion valve or auxiliary desuperheating expansion valve.

## Nomenclature/Ordering Instructions

S	DR	4	7/8 x 7/8	10	S
Step Motor Operated	Discharge Regulator	Nominal Size 3 or 4 Available	Connections ODF SDR-3, 3x - 3/8, 1/2, 5/8 SDR-4 - 7/8, 1-1/8	Cable Length 10' standard, 20,30,40 also available	S = Stripped and tinned cable ends. Custom Connectors available

For complete information see your Sporlan Wholesaler, our website at [www.sporlan.com](http://www.sporlan.com), or write Sporlan and request Bulletin 100-60.

# ▼ ELECTRONIC TEMPERATURE CONTROL SYSTEMS

CONTROLLER PACKAGES

Sporlan offers a variety of controllers for use in refrigeration and air conditioning systems. Applications include self-contained food service equipment, cold rooms and chillers. With over 80 different models, Sporlan can satisfy almost any customer requirement.

Small, standalone controllers include the compact Kelvin and larger Superheat and Refrigeration controllers. All are designed to provide true pressure/temperature superheat control of any system using Sporlan Electric Expansion Valves (EEVs). Chiller controllers offer true pressure/temperature superheat control for two Sporlan EEVs and are available in Fahrenheit/psi or Celsius/Bar versions.

Sporlan offers many purpose built controllers, such as subcoolers for supermarket refrigeration, as well as head pressure, temperature only and pressure only.

Cold rooms can be controlled with RCS, which has onboard remote communication, and master-slave settings for defrost control.

Included real time clocks allow defrost initialization times to be set precisely and relays allow control of fans, solenoids, alarms and compressors. Many of the controllers can be customized for specific needs, or supplied in an enclosure, please contact Product Manager, Electronic Products, Sporlan Division.

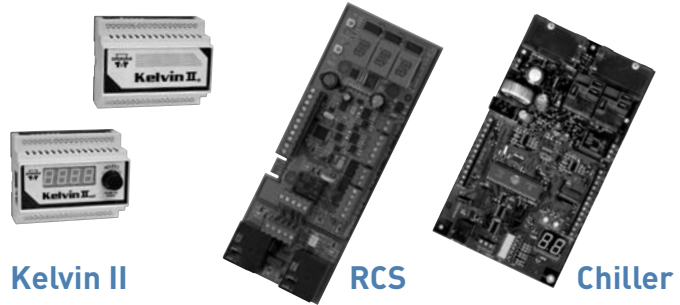

CONTROLLER PACKAGES	DISPLAY	COMMUNICATION	RELAYS	REFRIGERANTS	INPUTS*	VALVES	
<b>Kelvin II<sub>SD</sub></b>	Yes	RS-485	Two	R-22, R-134a, R-404A, R-507, R-410A, R-407C Not all refrigerants are available on all models.	1 Press, 3 Temp.	1 SER, SEI, ESX or SEHI	
<b>Kelvin II<sub>S</sub></b>	No	RS-485	Two		1 Press, 3 Temp.	1 SER, SEI, ESX or SEHI	
<b>RCS</b>	3 Alphanumeric	RS-485	Four		1 Press, 4 Temp.	1 SER, SEI, ESX or SEHI	
<b>Subcooler</b>	2 Numeric	None	None		1 Press, 2 Temp.	1 SER, SEI, ESX or SEHI	
<b>Chiller</b>	2 Numeric	None	Three		2 Press, 4 Temp.	2 SER, SEI, ESX or SEHI	
<b>Chiller European</b>	2 Numeric (C°/Bar)	None	Three		2 Press, 4 Temp.	2 SER, SEI, ESX or SEHI	
<b>Pressure</b>	2 Numeric	None	None		1 Press	1 CDS or 1 SDR	
<b>Dual Pressure Control</b>	2 Numeric	None	None		2 Press	2 CDS or 2 SDR or 1 of each	
<b>Temperature Control</b>	2 Numeric	None	None		1 Temperature	1 CDS or 1 SDR	
<b>Dual Temp. Control</b>	2 Numeric	None	None		2 Temperature	2 CDS or 2 SDR or 1 of each	
<b>Superheat</b>	2 Numeric	None	None		1 Press, 2 Temp.	1 SER, SEI, ESX, or SEHI	
<b>Superheat Low Temp.</b>	2 Numeric	None	None		1 Press, 2 Temp.	1 SER, SEI, ESX, or SEHI	
<b>Refrigeration</b>	2 Numeric	None	None		1 Press, 2 Temp.	1 SER, SEI, ESX, or SEHI	
SELF CONTAINED EQUIPMENT							
<b>Omnistat – Low Temp.</b>	3 Digit	RS 485 Optional	One			Defrost, Product, Digital**	N/A
<b>Omnistat – Med. Temp.</b>	3 Digit	RS 485 Optional	Three			Defrost, Product, Digital**	N/A

**Notes:**  
 \* See accessories page 69, only Sporlan approved sensors may be used.  
 \*\* All products control temperature, other functions not available on all models.

## ▼ OMNI-STAT<sup>®</sup> Temperature and Defrost Controller with Digital Display

Ideally suited for self-contained food service equipment, the Omni-Stat controller consolidates several system control functions and provides a visible display of the operating temperature. The OmniStat is a small package loaded with features.

All control parameters are either programmed with the front mounted, backlit, push buttons or an optional programming key. The programming key is convenient and efficient for programming multiple controllers with the same setting, in the field or on the manufacturing floor.

The front push buttons are also utilized to manually initiate a defrost, silence an alarm, or start the compressor.

Low temperature OmniStat models feature relays for fans, defrost heaters, and the compressor.

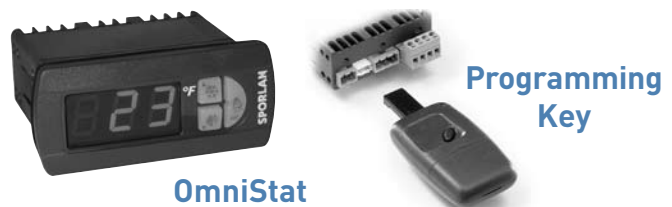

The low temperature controllers also provide an added temperature probe connection to accommodate temperature defrost termination along with time termination.

All OmniStat controllers have the ability to supply HACCP data to an external recording module.

## ▼ ELECTRONIC TEMPERATURE CONTROL SYSTEMS

CONTROLLER  
PACKAGES

### TCB Temperature Control Board/IB Interface Board

The TCB interface/controller was designed to allow all Sporlan step motors to be modulated in response to an externally generated signal. The IB and TCB will accept a 4-20 milliamp, or 0-10 volt DC inputs and will stroke the valve in proportion to that signal. The TCB and IB will allow use of the CDS or SDR valves with an existing DDC system or other generic temperature controller for hot gas bypass, evaporator temperature, or reclaim applications. **While the TCB and IB will also control Sporlan's line of ESX, SER, SEI and SEH step motor electric expansion valves, an external signal must be generated in response to superheat and not simply temperature. Please contact Sporlan for more information.**

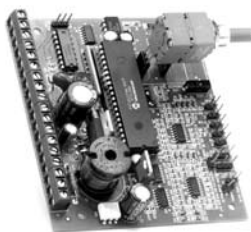

TCB will modulate the valve to maintain tight temperature control. The TCB can be configured to “close on rise” or “open on rise” and requires only an external 24 volt AC 40 VA power source. The TCB incorporates separate “pump down” contacts for use with external relays to allow even greater control choices. The TCB and IB have screw terminals for easy connections, and should be mounted in a control panel or other enclosure.

### SMA-12 Step Motor Actuator

The SMA-12 is an instrument designed to help diagnose systems with step motor valves by proving operation of the step motor. The unit is powered by two 9 volt alkaline batteries and will power any standard 12-volt DC bipolar step motor. Step rate is selectable at 1, 50, 100 or 200 steps per second and will stroke the motor in both the open and closed directions. Red lamps indicate continuity of the motor windings and battery power, and binding posts are provided for quick connection of the motor leads. In the event of a controller failure, the SMA-12 can be used to manually open or close the valve or manually step it to any position. The SMA-12 is the basic troubleshooting tool for all step motor valve operated systems.



When the TCB is purchased with optional set point potentiometer and sensor, the TCB becomes a stand alone single point temperature control for the CDS or SDR valves. The sensor is installed in the air stream or affixed to the pipe containing the liquid to be controlled. The potentiometer is set to the temperature desired, and the

ITEM NUMBER	DESCRIPTION	CONNECTOR
953276	SMA-12	Binding Post
953277	SMA-12 w/Pigtail	Packard Pigtail Item #958112

INTERFACE BOARDS	INPUT	VALVES*
TCB	4-20 ma, 0-10 VDC	SDR, CDS
TCB with Potentiometer	Temperature Sensor	SDR, CDS
IB-ESX	4-20 ma, 0-10 VDC	ESX
IB-1	4-20 ma, 0-10 VDC	SDR-3
IB-3	4-20 ma, 0-10 VDC	SDR-3, 3X
IB-6	4-20 ma, 0-10 VDC	SDR-4, CDS-4, -7, -9, -16, -17, Y1177

\* Interface boards may be used with electric expansion valves SER, SEI, SEHI, ESX only when used with external superheat controllers. Contact Sporlan for more information.

ACCESSORIES	ITEM NUMBERS	APPLICATION
0-150 psig Pressure Transducer 5' Cable (Green Color Code)	953091	RCS and Kelvin except R-410A
0-300 psig Pressure Transducer 5' Cable (Black Color Code)	952740	All except TCB, IB, and OmniStat
0-150 psig Pressure Transducer 10' Cable (Green Color Code)	953092	RCS and Kelvin except R-410A
0-300 psig Pressure Transducer 10' Cable (Black Color Code)	952503	All except TCB, IB, and OmniStat
0-500 psig Pressure Transducer 10' Cable (Yellow Color Code)	952505	Head Pressure and CO <sub>2</sub> Applications only
Surface Sensor - 2K (Black Color Code)	952662	All except RCS and Kelvin
Surface Sensor - 3K (White Color Code)	952551	RCS and Kelvin
Well Sensor	952795	All except IB, TCB less Potentiometer, RCS, and Kelvin
Air Sensor	952669	All except IB, TCB less Potentiometer, RCS, and Kelvin
Omnistat Sensor	952899	Omnistat only
SMA-12 Valve Actuator	953276	All 12 Volt DC Step Motor Valves

## ▼ OIL LEVEL CONTROL SYSTEM

Sporlan's Oil Level Control System Components were developed to offer the refrigeration industry an oil level control system of the highest quality. The heart of the system is the Oil Level Control which when matched with the Oil Reservoir and Oil Differential Check Valve maintains a minimum oil level in the compressor crankcase during all phases of system operation.

### Oil Reservoirs

Sporlan oil reservoirs are holding vessels for stand-by oil necessary for the operation of a commercial refrigeration or air conditioning system. The oil reservoir is shipped with service valves so the vessel can be isolated from the rest of the system.

### Features and Benefits

- **Sightglass ports with float ball indicators for oil level monitoring**
- **3/8" male flare rotalock valves shipped with oil reservoir allow for easy adjustment when piping into system**
- **3/8" male flare vent port – for connection to the suction line**
- **Mounting studs and brackets**
- **500 psi maximum working pressure**
- **Powder coating passes 500 hour ASTM salt spray**



### Oil Differential Check Valve Types OCV-5, -10, -20 and -30

The Sporlan Oil Level Differential Check Valve (OCV) is installed on the 3/8" SAE fitting on top of the OR-1-1/2, and allows pressure to be relieved from the reservoir to the suction as required to maintain a pressure in the reservoir at a preset level above the suction pressure. The pressure differential created by the OCV assures oil flow from the reservoir to the Oil Level Control providing there is adequate oil in the reservoir.

The OCV will only relieve pressure from the reservoir in excess of its fixed set point. Systems with fluctuating suction pressure as a result of compressor unloaders, staging or other suction line controls must be fitted with an OCV with a differential greater than the suction pressure fluctuation to assure oil flow from the oil reservoir through the oil level control to the compressor crankcase.

Sporlan offers OCV's with a 5, 10, 20 and 30 psi fixed differential setting. However, Sporlan recommends the use of an OCV-20 or OCV-30 on all field built up applications.

### Oil Level Controls

The purpose of the Sporlan Oil Level Control is to regulate the flow of oil to the compressor crankcase to maintain a minimum oil level as specified by the compressor manufacturer for any given application. The Oil Level Control is adjustable between 1/2 sightglass and 1/4 sightglass at any pressure differential between 5 and 90 psid. As the level of oil is lowered in the compressor crankcase by being pumped out, the float of the Oil Level Control is lowered and opens a needle valve allowing oil to flow from the oil reservoir to the compressor crankcase.



**OL-60XH**



MODEL NO.	TOTAL CAPACITY Gallons	'A' CAPACITY Gallons	'B' CAPACITY Gallons	NUMBER of SIGHT-GLASSES	LENGTH Inches	SHELL DIAMETER Inches
POR-2	2	3/4	3/4	2	18	6.0
POR-3	3	3/4	1-1/2	3	23	6.0
POR-4	4	3/4	2-3/4	3	36	6.0

'A' capacity is the capacity to the first sightglass.  
'B' capacity is the capacity **between** the two sightglasses for the POR-2 and the **top** and **bottom** sightglasses for the POR-3 and POR-4.

### Selection And Specifications

MODEL NUMBER	PRODUCT TYPE	FLANGE TYPE	COMPRESSOR MANUFACTURER and MODEL	CONFIGURATION TOP VIEW
OL-60CH	90 psi Max Differential	3 bolt	See page 71 for compressor adaptor requirements.	
OL-60XH		3 bolt		
OL-60ZH		4 bolt		
OL-60FH		3 bolt		
OL-60HH-6		3 bolt		
OL-60NH-2		3 bolt		
S-OL	Sightglass	Included with adaptor kits on page 71 (except AOL-R) or may be purchased separately.		

Note: 400 psi M.R.P.

For complete information see your Sporlan Wholesaler, our website at [www.sporlan.com](http://www.sporlan.com), or write Sporlan and request Bulletin 110-10 and 110-10-1.

## ▼ OIL LEVEL CONTROL SYSTEM

### Compressor Adaptor Requirements

COMPRESSOR MANUFACTURER	COMPRESSOR MODEL NUMBER	COMPRESSOR ATTACHMENT PATTERN	SPORLAN ADAPTOR KIT NUMBER	SEALING METHOD	SIGHTGLASS
Bitzer	2 KC, 2JC, 2HC, 2GC, 2FC, 2EC, 2DC, 2CC, 4FC, 4EC, 4DC, 4CC	1-1/8" Thread	AOL-MA/TE	Use seal provided	Use sightglass provided with adaptor
	4VC, 4TC, 4PC, 4NC	3 Bolt, 1-7/8" B.C. (47.6 mm B.C.)	None	Use seal provided	Use sightglass from compressor
	4J, 4H, 4G, 6J, 6H, 6G, 6F	4 Bolt, 50 mm B.C.	None with the OL-60ZH control	Use seal provided with control	Use sightglass from compressor
	8GC, 8FC	3 Bolt, 1-7/8" B.C. (47.6 mm B.C.)	AOL-R-1	Use seal provided	Use sightglass from compressor
Bock	HA3-5, HG3-5, AM/F2-5	4 Bolt, 50 mm B.C.	AOL-BO ①	Use Teflon tape	Use sightglass provided with adaptor
	HA8, HG6				
	F...	3 Bolt, 1-7/8" B.C. (47.6 mm B.C.)	AOL-R-1	Use seal provided	Use sightglass from compressor
Bristol	—	15/16" – 20 Thread	AOL-BR/TR	Use seal provided	Use sightglass provided with adaptor
Carrier	EA, ER	3 Bolt, 1-7/8" B.C. (47.6 mm B.C.)	AOL-R-1	Use seal provided	Use sightglass from compressor
	6E Front	3 Bolt, 1-7/8" B.C. (47.6 mm B.C.)	None		Use sightglass from compressor
	DA, DR, 5F, 5H, 6D, 6E	1-1/2" – 18 Thread	AOL-C		Use sightglass provided with adaptor
Copeland	Over 5 Ton	3 Bolt, 1-7/8" B.C. (47.6 mm B.C.)	AOL-R-1	Use seal provided	Use sightglass from compressor
	Under 5 HP ②	1-1/8" – 12 Thread	AOL-A	Use seal from compressor	Use sightglass provided with adaptor
	8R, 3D Front, 2D, 4D, 6D	3 Bolt, 1-7/8" B.C. (47.6 mm B.C.)	AOL-R-1	Use seal provided	Use sightglass from compressor
	8D	3 Bolt, 1-7/8" B.C. (47.6 mm B.C.)	Use control with standard length arms with AOL-R-1 adaptor. Use sightglass from compressor		
Dorin	4 cyc-15 HP	3 Bolt, 1-7/8" B.C. (47.6 mm B.C.)	Contact Sporlan		
Dunham-Bush	Big 4	3 Bolt, 1-7/8" B.C. (47.6 mm B.C.)	AOL-R-1	Use seal provided	Use sightglass from compressor
Frascold	All models	3 Bolt, 1-7/8" B.C. (47.6 mm B.C.)	AOL-R-1	Use seal provided	Use sightglass from compressor
Maneurop	MT..., LT...	1-1/8" – 18 Thread	AOL-MA/TE	Use seal provided	Use sightglass provided with adaptor
Prestcold	E, C	42 mm Thread	AOL-P	Use Teflon tape	Use sightglass provided with adaptor
Tecumseh	P, R, S, PA, RA, SA, CK, CM, CH, CG	1-1/8" – 12 Thread	AOL-A	Use seal from compressor	Use sightglass provided with adaptor
	—	1-1/8" – 18 Thread	AOL-MA/TE	Use seal provided	
Trane	M, R	3 Bolt, 1-7/8" B.C. (47.6 mm B.C.)	AOL-R-1	Use seal provided	Use sightglass from compressor
	K	3/4" NPT	AOL-K-1	Use Teflon tape	Use sightglass provided with adaptor
	—	15/16" – 20 Thread	AOL-BR/TR	Use seal provided	
York	GC, GS, JS	3 Bolt, 1-7/8" B.C. (47.6 mm B.C.)	AOL-R-1	Use seal provided	Use sightglass from compressor

**Note:** Shipping wt. is 4 lbs. for oil level controls and 1 lb. for adaptors.

① The OL-60ZH control is a possible option on select models. Use sightglass from compressor.

② Some compressor models have a smaller diameter port than the arm diameter of the oil level control. This situation can mislead the control in the amount of oil that is actually in the compressor. It is advisable the selection and adjustment of the control be reviewed in this situation.

For complete information see your Sporlan Wholesaler, our website at [www.sporlan.com](http://www.sporlan.com), or write Sporlan and request Bulletin 110-10.

## ▼ SERIES OIL FILTER

### Design Benefits

- Virtually eliminates the need for oil changes due to suspended particulate in circulation
- Unsurpassed filtering efficiency
  - 99% removal of 3 micron sized particles
  - 98% removal of 2 micron sized particles
- Element utilizes a pleated design for maximum surface area
- Unsurpassed filtration capacities
- High flow capacities with low pressure drop
- Filter element utilizes an O-ring seal
- Inert microglass filter material ensures lubricant compatibility
- Dimensions allow for easy replacement of current filter



The Sporlan Catch-All or SF-283-F Suction Filter has been used for many years as an oil filter in refrigeration rack systems with mineral or alkylbenzene oil.

With the use of the new polyolester (POE) oils, system chemistry changed. Unlike mineral and alkylbenzene oils, POE oil has solvent-like tendencies. POE oil has the ability to suspend and recirculate small, solid contaminants left from system installation or retrofit. Analysis of POE oil samples taken from actual systems have shown the oil to suspend and recirculate a high concentration of 2-20 micron sized particles, with the largest percentage between 2-10 microns. Although some particles are smaller than bearing tolerances, studies have shown bearing life can still be affected. Bearing wear depends upon the size, hardness, and concentration of particles in circulation. To effectively remove these small particles, Sporlan developed a new type of oil filter.

The **OF Series Oil Filters** are designed to be 99% efficient in removing 3 micron sized particles and yet have sufficient flow capacity at a low pressure drop. The unsurpassed filtration ability of the oil filters will assure clean POE, mineral or alkylbenzene oil is returned to the compressors. Clean oil ensures proper operation of the oil level control and minimizes compressor wear. The Sporlan OF Series Oil Filters were designed to virtually eliminate the need for oil changes resulting from suspended solid contaminants in circulation.

### Specifications

UNIT	DESCRIPTION	CONNECTIONS	FILTERING AREA Sq. Inches	OVERALL LENGTH Inches	SHELL DIAMETER Inches	UL RATED WORKING PRESSURE – psi
OF-303-T	Oil Filter	3/8" SAE Flare	325	9.69	3.00	500
OF-303-BP-T	Oil Filter with Bypass Feature			10.63		
ROF-413-T*	Replaceable Oil Filter	Field Support		8.12	3.50	400

\*An OFE-1 Replaceable Filter Element must be purchased separately. The A-175-1 mounting bracket can be used for the ROF-413T Replaceable Oil Filter.

**Note:** The OF Series Oil Filters are not suitable for use on ammonia systems

For complete information see your Sporlan Wholesaler, our website at [www.sporlan.com](http://www.sporlan.com), or write Sporlan and request Bulletin 110-10.

## ▼ ACID TEST KITS

TYPE TA-1 and AK-3

### Designed to Test Mineral, Alkylbenzene and POE Lubricants

- Thoroughly field proven
- Takes the guesswork out of service work

TA-1



### Design Benefits

- **Builds Customer Confidence** – Show the test results of the acid test kit to customers, or perform the test in their presence. In this way they realize you are using the most up-to-date scientific method for system maintenance. Showing customers the test results will also help to convince them to spend the money necessary to do a proper clean-up job. Customers who are thoroughly confident of your abilities will be more interested in establishing preventive maintenance programs.
- **Accurate and Reliable** – Using a simple, scientific method, you can precisely measure the amount of acid in a lubricant sample taken from a contaminated system. The test procedure has been proven by extensive field experience.

- **Convenient** – Both the TA-1 and AK-3 are convenient to use. The TA-1 has pre-measured solutions supplied in bottles with screw caps for easy handling. The AK-3 has all solutions and bottles supplied in a small fitted case. Either kit may be used on the job site, or a lubricant sample can be saved and tested in the presence of the equipment owner.
- **Lubricant Sample Used for Test** – Since lubricant is the scavenger, it gives the best indication of acid in the system. Less than an ounce of lubricant is required.
- **Quick to Use** – Once the lubricant sample is obtained...it will take only minutes to perform the test. Simply mix the solutions and lubricant to be tested. Shake, and the resulting color tells the complete story.
- **Cost** – The cost of the test is very inexpensive, regardless of which kit is used. The TA-1 Kit is more convenient, but for repeated testing the AK-3 is less costly.

Both the TA-1 and AK-3 Kits are normally used on a “pass or fail” basis. If the user desires an indication of the relative **amount** of acid in the lubricant, then the AK-3 Kit should be selected.

For complete information see your Sporlan Wholesaler, our website at [www.sporlan.com](http://www.sporlan.com), or write Sporlan and request Bulletin 40-10.







# CLIMATE CONTROL

- Accumulators
- CO<sub>2</sub> controls
- Electronic controllers
- Filter-driers
- Hand shut-off valves
- Heat exchangers
- Hose & fittings
- Pressure regulating valves
- Refrigerant distributors
- Safety relief valves
- Solenoid valves
- Thermostatic expansion valves



## AEROSPACE

- Flight control systems & components
- Fluid conveyance systems
- Fluid metering delivery & atomization devices
- Fuel systems & components
- Hydraulic systems & components
- Inert nitrogen generating systems
- Pneumatic systems & components
- Wheels & brakes



## HYDRAULICS

- Diagnostic equipment
- Hydraulic cylinders & accumulators
- Hydraulic motors & pumps
- Hydraulic systems
- Hydraulic valves & controls
- Power take-offs
- Quick disconnects
- Rubber & thermoplastic hose & couplings
- Tube fittings & adapters



## ELECTROMECHANICAL

- AC/DC drives & systems
- Electric actuators, gantry robots & slides
- Electrohydraulic actuation systems
- Electromechanical actuation systems
- Human machine interfaces
- Linear motors
- Stepper motors, servo motors, drives & controls
- Structural extrusions



## PNEUMATICS

- Air preparation
- Brass fittings & valves
- Manifolds
- Pneumatic actuators, grippers, valves, controls & accessories
- Quick disconnects
- Rotary actuators
- Rubber & thermoplastic hose & couplings
- Structural extrusions
- Thermoplastic tubing & fittings
- Vacuum generators, cups & sensors



## FILTRATION

- Analytical gas generators
- Compressed air & gas filters
- Condition monitoring
- Engine air, fuel & oil filtration & systems
- Hydraulic, lubrication & coolant filters
- Process, chemical, water & microfiltration filters
- Nitrogen, hydrogen & zero air generators



## PROCESS CONTROL

- Analytical sample conditioning products & systems
- Fluoropolymer chemical delivery fittings, valves & pumps
- High purity gas delivery fittings, valves & regulators
- Instrumentation fittings, valves & regulators
- Medium pressure fittings & valves
- Process control manifolds



## FLUID & GAS HANDLING

- Brass fittings & valves
- Diagnostic equipment
- Fluid conveyance systems
- Industrial hose
- PTFE & PFA hose, tubing & plastic fittings
- Quick disconnects
- Rubber & thermoplastic hose & couplings
- Tube fittings & adapters



## SEALING & SHIELDING

- Dynamic seals
- Elastomeric o-rings
- EMI shielding
- Extruded & precision-cut, fabricated elastomeric seals
- Homogeneous & inserted elastomeric shapes
- High temperature metal seals
- Metal & plastic retained composite seals
- Thermal management

