

# SIEMENS

Installation - Operation - Maintenance  
Instalación - Operación - Mantenimiento

## Instructions / Instrucciones

Horizontal and vertical induction motors



Motores de inducción verticales y horizontales

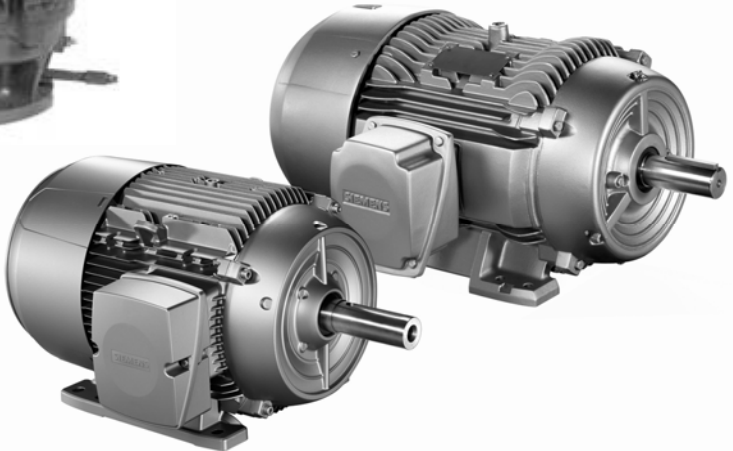

- All types / Todos los tipos
- All enclosures / Todos los armazones
- Polyphase / Polifásico



# ENGLISH

	 <b>DANGER</b>
	<p><b>Hazardous voltages and high-speed moving parts.</b> <b>Will cause death, serious injury or property damage.</b></p> <p>Always de-energize and ground the equipment before maintenance. Read and understand this instruction manual before using equipment.</p> <p>Maintenance should be performed only by qualified personnel. Use only Siemens parts in the repair of the equipment. Do not allow tampering with the equipment. Follow all safety instructions contained herein.</p>

**IMPORTANT**

The information contained herein is general in nature and not intended for specific application purposes. It does not relieve the user of responsibility to use sound practices in application, installation, operation, and maintenance of the equipment purchased. Siemens reserves the right to make changes in the specifications shown herein or to make improvements at any time without notice or obligations. Should a conflict arise between the general information contained in this publication and the contents of drawings or supplementary material or both, the latter shall take precedence.

## QUALIFIED PERSON

For the purpose of this manual a qualified person is one who is familiar with the installation, construction and operation of the equipment and the hazards involved. In addition, this person has the following qualifications:

- (a) **Is trained and authorized** to de-energize, energize, clear, ground, and tag circuits and equipment in accordance with established safety practices.
- (b) **Is trained** in the proper care and use of protective equipment such as rubber gloves, hard hat, safety glasses or face shields, flash clothing, etc., in accordance with established safety practices.
- (c) **Is trained** in rendering first aid.

## NOTE

These instructions do not purport to cover all details or variations in equipment, nor to provide for every possible contingency to be met in connection with installation, operation, or maintenance. Should further information be desired or should particular problems arise which are not covered sufficiently for the purchaser's purposes, the matter should be referred to the local sales office. The contents of this instruction manual shall not become part of or modify any prior or existing agreement, commitment or relationship. The sales contract contains the entire obligation of Siemens. The warranty contained in the contract between the parties is the sole warranty of Siemens. Any statements contained herein do not create new warranties or modify the existing warranty.



**DANGER**



**Hazardous voltages and high-speed moving parts.**

**Will cause death, serious injury or property damage.**

Always de-energize and ground the equipment before maintenance. This equipment must be installed, operated and maintained only by qualified persons thoroughly familiar with the equipment, instruction manuals and drawings. Read and understand this instruction manual before using equipment.

### **Signal Words**

The signal words “**Danger**”, “**Warning**” and “**Caution**” used in this manual indicate the degree of hazard that may be encountered by the user. These words are defined as:

**Danger** – Indicates an imminently hazardous situation which, if not avoided, will result in death or serious injury.

**Warning** – Indicates a potentially hazardous situation which, if not avoided, could result in death or serious injury.

**Caution** – Indicates a potentially hazardous situation which, if not avoided, may result in minor or moderate injury.

**Caution (Without safety alert symbol)** – indicates a potentially hazardous situation which, if not avoided, may result in property damage.

# INSPECTION

Care is taken at the factory to assure that the motor arrives at its destination in first class condition. If there is evidence of rough handling or damage in shipping, file a claim at once with the carrier and notify your local Siemens sales office.

Examine the outside of the motor carefully for damage, with particular attention to conduit box, fans, and covers. Inspect and tighten all hardware and accessories which may have become loosened during shipping and handling. Turn the shaft by hand to be sure that it rotates freely (be careful of shaft keyway sharp edges). If the motor has been mishandled sufficiently to break external parts, the end shield should also be removed to check for internal damage unless the motor is explosion-proof.

See warning below on explosion proof motors.



## DANGER

**Explosion-proof motors**—these motors are constructed to comply with the U.L. Label Service Procedure Manual. When repairing and reassembling a motor that has an Underwriter's label, it is imperative that the unit be re-inspected and:

1. All original fits and tolerance be maintained.
2. All plugs and hardware be securely fastened.
3. Any parts replacements, including hardware, be accurate duplicates of the originals.

Repair work on explosion-proof motors can only be done by the original manufacturing or U.L. certified shops. Violations of any of the above items will invalidate the significance of the U.L. label.

# CAUTION

**HANDLING** – Although motors are ruggedly constructed they should be handled with care. Dropping or jarring a motor can seriously damage its bearings. When lifting, use a device with capacity to handle the motor. If eyebolts are provided, use them to lift the motor only and be sure they are fully threaded into the stator housing. Do not lift motor with a bent eyebolt or cause the lifting device to pull at an angle on the eyebolt.

**STORAGE** - Motors must be stored in a clean, dry, well ventilated location free from vibration and rapid or wide temperature variations. If the unit is to be stored longer than three months, consult factory. Ball bearing motors are shipped from the factory properly lubricated and ready to operate. When in storage, the motor shaft must be turned several rotations every month and the bearing relubricated every year. On non-explosion-proof TEFC motors, a removable plug in the bottom of the frame or housing permits removal of accumulated moisture. Drain regularly if storage atmosphere results in formation of condensation.

**INSTALLATION** – Installation must be handled by qualified service or maintenance personnel. The motor foundation must rigidly support all four feet in the same plane. Place shims under the motor feet, as required, so they will not be pulled out of plane when mounting bolts are tightened. All wiring to the motor and control must be in accordance with the National Electrical Code and all local regulations. Before drive is connected, momentarily energize motor to check that direction of rotation is proper. For direct drive, accurate alignment is 0.004 inch/ft. (radius to dial indicator = one foot) Any change in shims requires rechecking alignment. When alignment is within limits, dowel two feet of each unit. When installing flat belt pulley, V-belt sheave, spur or helical pinion or chain drives, be certain that they are within NEMA limitations. Refer to NEMA motor and generator standards, MG-1 14.7 and 14.42.

**Terminal Box** – In the case of SD and GP motors, the terminal box can be turned through 4 x 90 degrees.

For GPA motors, the terminal can be turned 4 x 90 degrees, but care should be taken, when the outlet is toward the drive end.

**OPERATION** – Repeated trial starts can overheat the motor and may result in motor burnout (particularly for across the line starting). If repeated trial starts are made, allow sufficient time between trials to permit heat to dissipate from windings and rotor to prevent overheating. Starting currents are several times running currents, and heating varies as the square of the current.

**Initial Start** – After installation is completed, but before motor is put in regular service, make an initial start as follows:

1. Check motor starting and control device connections against wiring diagrams.
2. Check voltage, phase, and frequency of line circuit (power supply) against motor nameplate.
3. If possible, remove external load (disconnect drive) and turn shaft by hand to ensure free rotation. This may have been done during installation procedure; if so, and conditions have not changed since, this check may not be necessary.
  - a. If drive is disconnected, run motor at no load long enough to be certain that no unusual conditions develop. Listen and check for excessive noise, vibration, clicking, or pounding. If present, stop motor immediately. Investigate the cause and correct before putting motor in service.
  - b. If drive is not disconnected, interrupt the starting cycle after motor has accelerated to low speed. Carefully observe for unusual conditions as motor coasts to a stop.
4. When checks are satisfactory, operate at minimum load and look for unusual condition. Increase load slowly to maximum. Check unit for satisfactory operation.

# CAUTION

**LOADING** – Guard against overloading. Overloading causes overheating and overheating means shortened insulation life. A motor subjected to a 10°C temperature rise above the maximum limit for the insulation may cause the insulation life to be reduced by 50%. To avoid overloading, be sure motor current does not exceed nameplate current when nameplate voltage is applied.

**Temperature** - Electric motors operating under normal conditions become quite warm. Although some places may feel hot to the touch, the unit may be operational within limits. Use a thermocouple to measure winding temperature when there is any concern.

**The total temperature**, not the temperature rise, is the measure of safe operation. Investigate the winding operating conditions. The total temperature should not exceed:

230°F (110°C) for class “B” insulation

275°F (135°C) for class “F” insulation

302°F (150°C) for class “H” insulation

**VOLTAGE REGULATION** – Motors will operate successfully under the following conditions of voltage and frequency variation, but not necessarily in accordance with the standards established for operation under rated conditions:

- a. When the variation in voltage does not exceed 10% above or below normal, with all phases balanced.
- b. When the variation in frequency does not exceed 5% above or below normal.
- c. When the sum of the voltage and frequency does not exceed 10% above or below normal (provided the frequency variation does not exceed 5%).

**MAINTENANCE** – Failure to properly maintain the equipment can result in severe personal injury and product failure. The instructions contained herein should be carefully reviewed, understood and followed. The following maintenance procedures should be performed regularly:

1. Bearing lubrication
2. Insulation resistance check
3. Cleaning

This checklist does not represent an exhaustive survey of maintenance steps necessary to ensure safe operation of the equipment. Particular applications may require further procedures. Should further information be desired or should particular problems arise which are not covered sufficiently for the purchaser’s purposes, the matter should be referred to the local Siemens sales office.

Dangerous voltages are present in the equipment which can cause severe personal injury. Always de-energize and ground the equipment before maintenance. Maintenance should be performed only by qualified personnel.

The use of unauthorized parts in the repair of the equipment, tampering by unqualified personnel, or removal or alteration of guards or conduit covers will result in dangerous conditions which can cause severe personal injury or equipment damage. Follow all safety instructions contained herein.

## **BEARING LUBRICATION**

### **CAUTION**

Do not lubricate motor while in operation, since excess of grease will be forced through the bearings and into the motor before it will force its way out of the drain plug. Excess grease accumulation on windings reduces insulation life.

**Bearings** – Long life of bearing is assured by maintaining proper alignment, proper belt or chain tension, and good lubrication at all times.

**Lubrication** – Prior to shipment, motor bearings are lubricated with the proper amount and grade of grease to provide six months of satisfactory service under normal operation and conditions.

**Grease** – For Best results, grease should be compounded from a polyurea base and a good grade of petroleum oil. It should be of No. 2 consistency and stabilized against oxidation. Operating temperature range should be from -15°F to +250°F for class “B” insulation, and to +300°F for class “F” and “H”. Most leading oil companies have special bearing greases that are satisfactory.

Relubricate bearings every six months (more often if conditions require), as follows:

1. Stop the motor. Lock out the switch.
2. Thoroughly clean off pipe plugs and remove from housings.
3. Remove hardened grease from drains with stiff wire or rod.
4. Add grease to inlet with hand gun until small amount of new grease is forced out of drain.
5. Remove excess grease from ports, replace inlet plugs, and run motor ½ hour before replacing drain plug.
6. Put motor back in operation.

## CAUTION

Relubricate with the type of grease specified above or one that is compatible. Mixing greases of different bases (lithium, clay, polyurea, etc.) will cause bearing failure or malfunction and should not be done. All grease must be removed from the bearings and housings when making a non-compatible grease change.



## INSULATION RESISTANCE

Check insulation resistance periodically, (approx. every 5,000 hours of operation). Any approved method of measuring insulation resistance may be used, provided the voltage across the insulation is at a safe value for the type and condition of the insulation. A hand cranked megger of not over 500 volts is the most convenient and safest method. Standards of the Institute of Electrical and Electronics Engineers, Inc. (IEEE) recommended that the insulation resistance of stator windings at 75°C, measured at 500 volts DC, after one minute should not be less than:

$$\frac{\text{Rated voltage of machine} + 1000}{1000} = \text{Insulation resistance in Mega ohms}$$

This formula is satisfactory for most checks. For more information, see IEEE Standard No. 43, "Recommended Practice for Insulation Resistance Testing of AC Rotating Machinery".

## CLEANING

	 <b>DANGER</b>
	<p><b>Hazardous voltages and high-speed moving parts.</b> <b>Will cause death, serious injury or property damage.</b> Do not attempt to clean motor while it is operating. Stop the motor and lock out switch before cleaning.</p>

The motor exterior must be kept free of oil, dust, dirt, water, and chemicals. For fan cooled motors, it is particularly important to keep the air intake openings free of foreign material. Do not block air outlet or inlet.

**Moisture** – On non-explosion-proof TEFC motors, a removable plug in the bottom center of the motor frame or housing permits removal of accumulated moisture. Drain regularly.

## **VERTICAL MOTORS THRUST BEARINGS**

**Top bearings** – High external thrust from the driven unit is usually carried by the top bearing or bearings. If replacement is necessary, the new bearing must be the same size and type as the original. Duplex bearings must also be the same type and mounted in an identical manner. When angular contact type bearings are replaced, the new bearing must have the same thrust capacity.

**Bottom bearings** – Grease lubricated lower bearings are adequately lubricated at the factory for at least three months operation. The relubrication procedure is the same as outlined above, under “Bearing Lubrication.” It is important to maintain the lower cavity full of grease at all times.

The correct replacement bearings are given on the nameplate by AFBMA (Anti-Friction Bearing Manufacturers Association) number.

## **OVER PAINTING**

When over painting, contact the factory for more information.

## **MOTOR SERVICE**

For immediate action on your motor problems call your certified service center or contact your nearest Siemens district office.