

SHARPE[®] VALVES

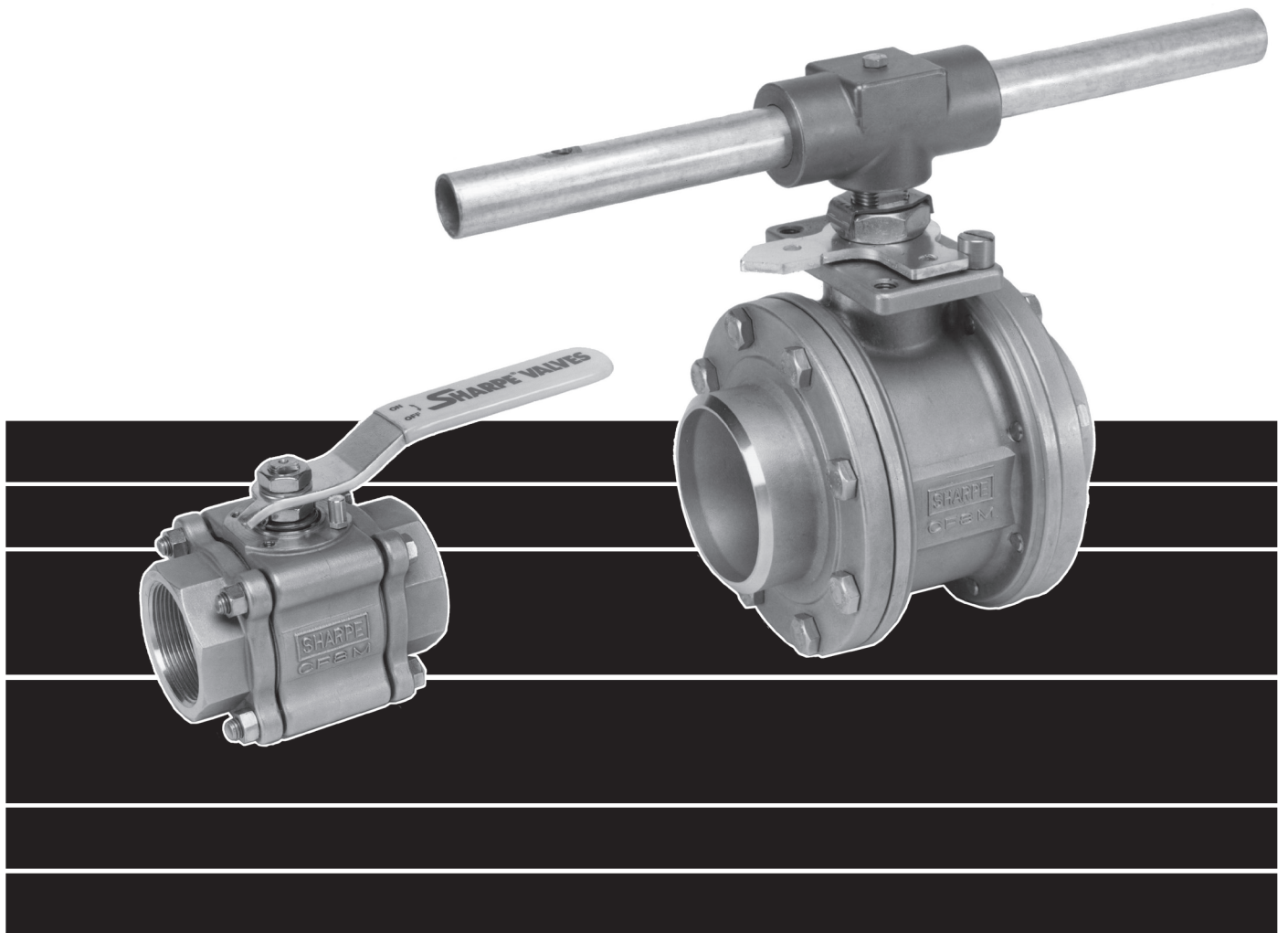

**SERIES 84
HIGH PERFORMANCE
3 PIECE BALL VALVES**

SHARPE[®] HIGH PERFORMANCE VALVES

Sharpe[®] Series 84 Ball Valves offer as standard features, advantages that other valve manufacturers offer only as costly extras. This is the Sharpe[®] advantage.

STANDARD FEATURES

3-Piece Design

Bottom Entry Live Loaded Stem

High Cycle Stem Packing

Fully Encapsulated Body Seals

Integral Mounting Pad

Lockable Handle

Slotted Seat Design

Choice of Seats and Seals

Variety of End Combinations

Floating Ball Design

Encapsulated Body Bolts

Traceability

ADVANTAGES

In-line serviceable swing-out center section allows easy access to internal valve components without disturbing alignment of pipe. Functions as both valve and union.

Self adjusts with pressure and temperature fluctuations. Blow-out proof anti-static design helps prevent accidents and injuries.

PEEK and Nova* thrust bearings and stem seals extend valve cycle life over conventional ball valves and are the best choice for actuation.

Allows valve ends to be welded in line without disassembly, saving costly labor time. Also prevents seal ruptures in high pressure or steam applications.

Ideal for actuation. Centering lip feature assures precise alignment of bracket, stem and coupler. Actuators may be retrofitted on existing Series 84 without disruption of line integrity. Allows for secondary containment unit to be added when necessary.

All Sharpe[®] Series 84 Valves meet OSHA standards with locking device. Keeps valves from being opened or closed accidentally.

Relief slots help equalize body pressure, reduce torque and assure leak-tight sealing. Seats also provide a wiping action that cleans ball and seats each time valve is cycled.

A wide variety of seat and seal materials are readily available for the most demanding applications, including Buna, Delrin, Nova*, PEEK, EPDM, Viton[®], TFE, RTFE, TFM[®], Grafoil, and UHMWPE.

A wide choice of optional end connections are available including, but not limited to threaded ends, socket weld ends, butt weld ends, flush bottom tank pads, flanged ends.

Precision engineered solid stainless steel ball with relief hole in stem slot prevents build up of cavity pressure while valve is in open position. Bi-directional floating ball seats downstream reduce torque and guarantee a bubble-tight shut off.

Heavy duty stainless steel bolting is protected from outside environment assuring valve integrity.

Heat numbers are provided on all valve bodies and ends. CMTR's (certified mill test reports) are available upon request.

* Carbon and Graphite Filled TFE
*** TFM is a trademark of DYNELON, LLC.

SERIES 84 VALVE PARTS AND IDENTIFICATION

1/4", 3/8", 1/2"

3/4" - 2-1/2"

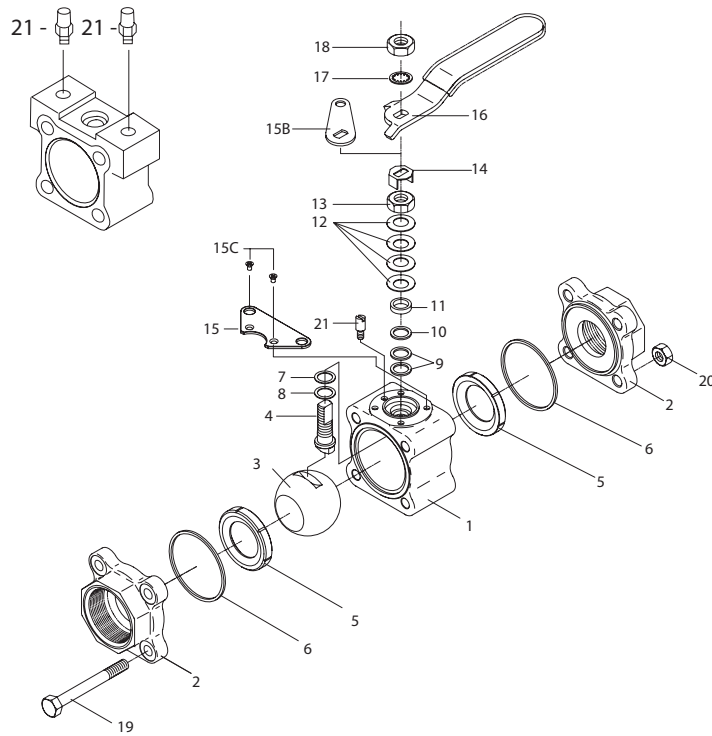

PART NO.	PART	QTY.	MATERIAL
1	Body*	1	316 Stainless Steel Alloy 20 Carbon Steel Hastelloy C Monel Brass
2	Pipe Ends*	2	316L Stainless Steel Alloy 20 Carbon Steel Hastelloy C Monel Brass
3	Ball	1	316 Stainless Steel Monel Brass
4	Stem	1	316 Stainless Steel Alloy 20 Monel 17-4PH (Standard - Brass
5	Valve Seat	2	TFE TFM (Super TFE) UHMWPE
6	Body Seal	2	Reinforced TFE Nova Delrin PEEK
7	Thrust Bearing	1	Nova (UHMWPE with UHMWPE Seats)
7A	Stem Location Ring (3" & 4")	1	Stainless Steel
8	Thrust Bearing	1	PEEK (UHMWPE with UHMWPE Seats)
8A	Thrust Bearing	1	Nova (UHMWPE with UHMWPE Seats)
9	Stem Packing	2	Nova (UHMWPE with UHMWPE Seats)
9A	Stem Packing (3" & 4")	3	Nova (UHMWPE with UHMWPE Seats)
10	Seal Protector	1	PEEK
11	Gland Packing	1	Stainless Steel

APPLICABLE STANDARDS	
Body Wall Thickness	ASME B16.34
SW & Threaded Ends	ASME B16.11
Butt-weld Ends	ASME B16.25
Flange Dimensions	ASME B16.5
Basic Design	ASME B16.34 (note 1)
Testing (Options)	ASME B16.34 API 598

Note 1: When specified, valves can be furnished in accordance with ASME B16.34 requirements.

3" - 4"

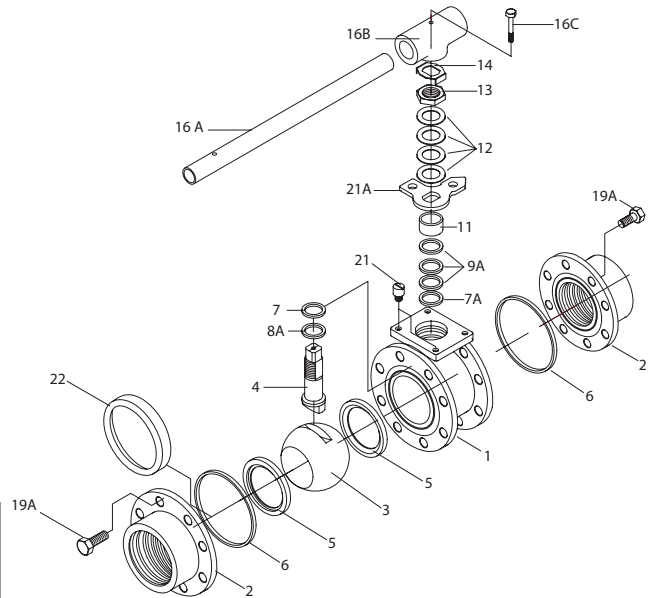

PART NO.	PART	QTY.	MATERIAL
12	Belleville Washer	4	Stainless Steel
13	Packing Nut	1	Stainless Steel
14	Lock Tab	1	Stainless Steel
15	Lower Lock Latch	1	Stainless Steel
15B	Upper Lock Latch Bolt	1	Stainless Steel
15C	Latch Bolt	1	Stainless Steel
16	Handle (1/4"-2")	1	Stainless Steel
16A	Wrench (3" & 4")	1	Cad Plate Carbon Steel
16B	Wrench Block	1	Stainless Steel
16C	Hex Head Bolt	1	Stainless Steel
17	Lock Washer	1	Stainless Steel
18	Handle Nut (1/4"-2")	1	Stainless Steel
19	Body Bolts	4	Stainless Steel
19A	Body Connector Nut	8	Stainless Steel
20	Nuts	4	Stainless Steel
21	Stop Pin (1/4"-1/2")	1 2	Stainless Steel Stainless Steel
21A	Stopper	1	Stainless Steel
22	Seat Retainer	1 1	Stainless Steel Carbon Steel

* Valves furnished with Delrin or PEEK seats will use a tongue and groove joint design for the body end seal configuration.

SERIES 84 DIMENSIONS

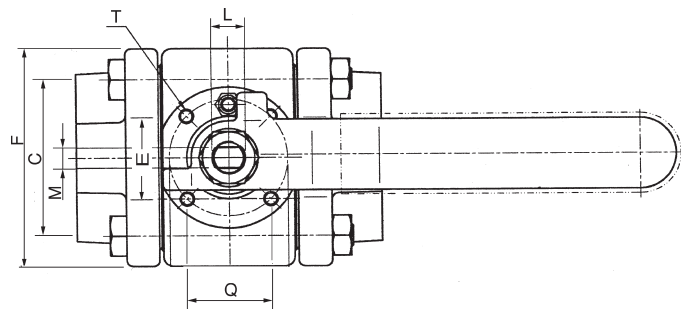
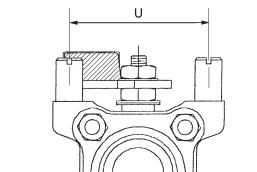
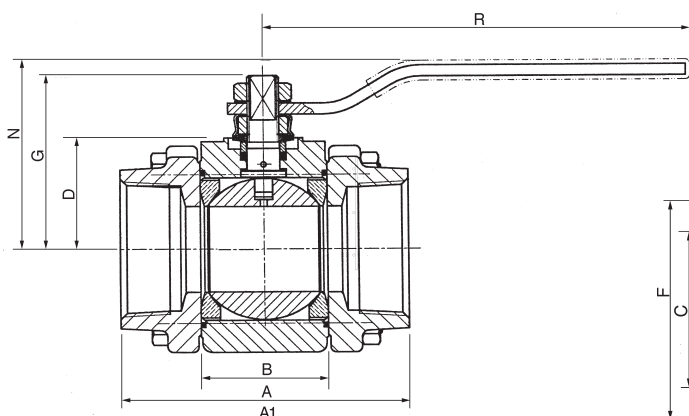

SIZE	A	A1(BW)	B	C	D	E	F	G	L	M	N	Q	R	T	1/4", 3/8" & 1/2"	V
1/4"	2.54	2.62	.813	1.25	.939	-	1.75	1.50	3/8" -24 UNF	.22	1.76	-	4.62	1/4" -20 UNC	1.90	.28
3/8"	2.54	2.62	.813	1.25	.939	-	1.75	1.50	3/8" -24 UNF	.22	1.76	-	4.62	1/4" -20 UNC	1.90	.28
1/2"	2.54	2.62	.813	1.25	.939	-	1.75	1.50	3/8" -24 UNF	.22	1.76	-	4.62	1/4" -20 UNC	1.90	.28
3/4"	2.78	2.87	.969	1.50	1.24	1.00	2.05	1.59	3/8" -24 UNF	.22	1.87	1.00	4.50	M5	-	.28
1"	3.68	3.72	1.25	1.75	1.51	1.18	2.42	2.19	7/16" -20 UNF	.30	2.40	1.18	5.75	M5	-	.30
1-1/4"	4.22	4.24	1.63	2.00	1.65	1.18	2.70	2.38	7/16" -20 UNF	.30	2.70	1.18	5.75	M5	-	.30
1-1/2"	4.55	4.58	1.91	2.25	1.71	1.38	3.16	2.88	9/16" -18 UNF	.35	3.16	1.38	7.00	M6	-	.42
2"	5.00	5.03	2.22	2.62	1.87	1.38	3.56	3.06	9/16" -18 UNF	.35	3.35	1.38	7.00	M6	-	.42

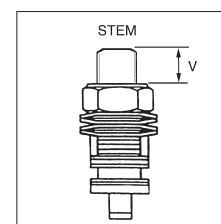
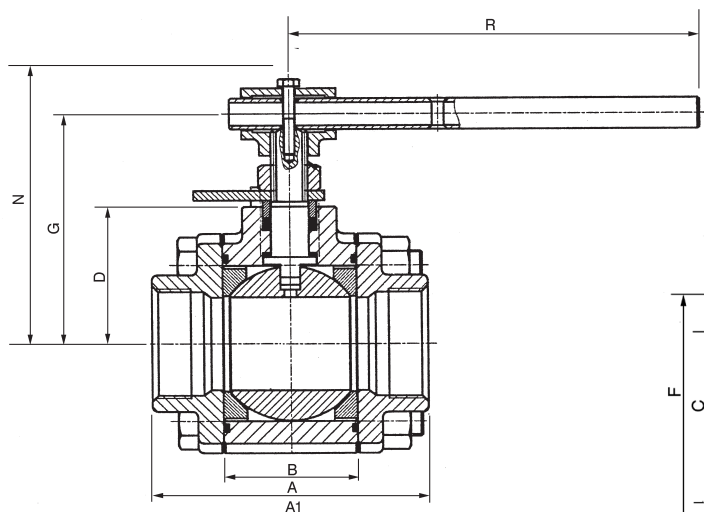

1/4" - 4"
STEM ARRANGEMENT
FOR ACTUATORS

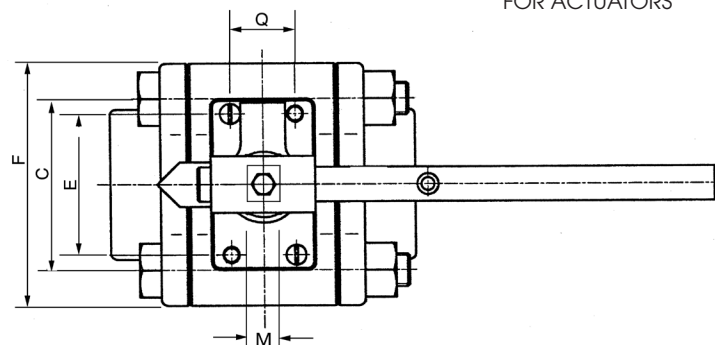

SIZE	A	A1(BW)	B	C	D	E	F	G	L	M	N	Q	R	T	V
2-1/2"	5.86	5.86	2.86	3.35	2.92	2.75	4.57	4.56	M20	.55	5.58	1.25	10.00	M8	.55

SERIES 84 DIMENSIONS



SIZE	A	A1(BW)	B	C	D	E	F	G	L	M	N	Q	R	T	V
3"	6.66	6.66	3.28	5.50	3.92	3.38	6.44	6.52	1"-14 UNS	.745	7.62	1.75	13.8	M10	.66
4"	8.40	8.40	4.28	6.97	4.48	3.38	8.12	7.08	1"-14 UNS	.745	8.18	1.75	22.00	M10	.66

PERFORMANCE DATA

VALVE SIZE	FLOW COEFF. Cv	EQUIVALENT LENGTH OF SCH. 40 PIPE FEET	APPROX. WEIGHT	PORT SIZE
1/4"	8	1.9	1.20	.44
3/8"	8	1.9	1.20	.44
1/2"	8	1.9	1.20	.44
3/4"	12	6.3	1.70	.56
1"	32	3.1	3.00	.81
1-1/4"	46	6.3	4.00	1.00
1-1/2"	80	4.3	6.00	1.25
2"	120	7.5	8.00	1.50
2-1/2"	240	5.00	25.00	2.00
3"	350	8.3	30.00	2.50
4"	720	10.4	50.20	3.25

Due to ongoing development of our product line, specifications subject to change without notice.

1. TFM seats are standard. Other seat materials are readily available.
- 2.. Delrin and UHMWPE seats should not be used for steam service.
3. Delrin must not be used in Oxygen applications.

SEAT PRESSURE/TEMPERATURE RATING SERIES 84

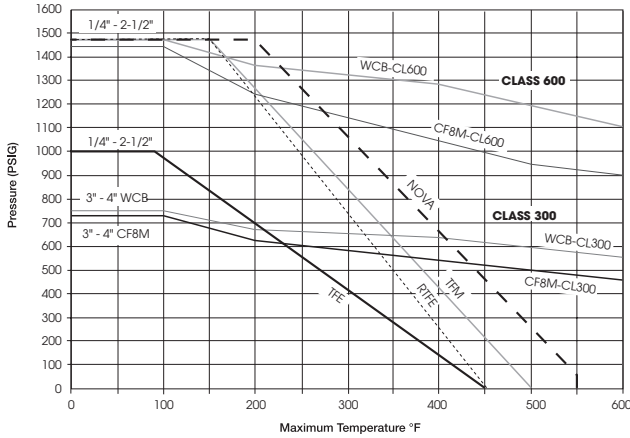

SEAT PRESSURE/TEMPERATURE RATING SERIES 84

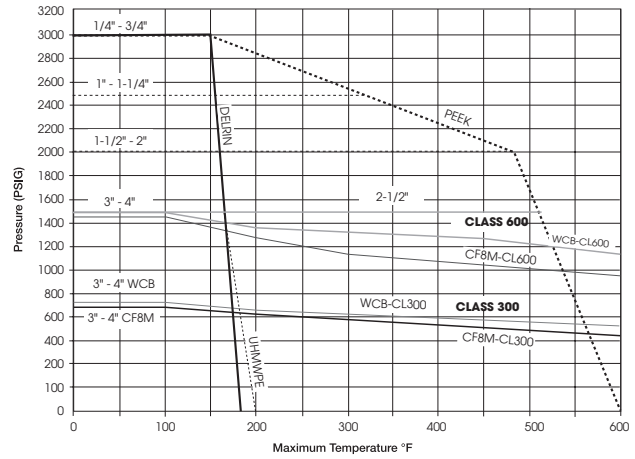

SEAT PRESSURE/TEMPERATURE RATING SERIES 84 - BRASS

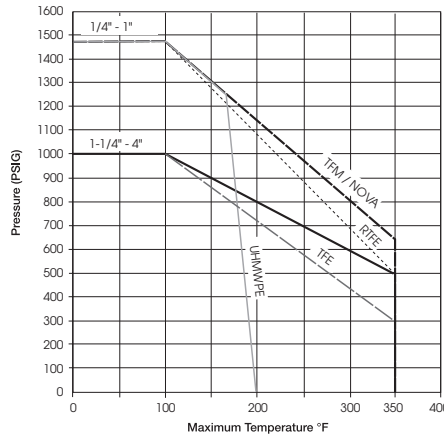

HOW TO ORDER

VALVE SIZE	VALVE SERIES	BODY & ENDS	BALL & STEM	SEAT	SEAL	ENDS	OPTIONS
1/4"	84	4 = Carbon Steel	6 = 316 S/S	T = TFE	B = Buna	TE = Threaded Ends (NPT)	X = Oxygen Service
3/8"		6 = Stainless Steel	2 = Alloy 20	R = Reinforced TFE	N = Neoprene	TEB = Threaded Ends (BSPT)	OH = Oval Handle
1/2"		2 = Alloy 20	3 = Monel	N = Nova	V = Viton®	BW = Butt Weld Sch. 5, 10, 40, & 80	F = Fugitive Emissions Certified ANSI S93.00.01
3/4"		3 = Monel	5 = Hastelloy C	D = Delrin	T = TFE	SW = Socket Weld	E = Extended Stem
1"		5 = Hastelloy C	1 = Brass	U = UHMWPE	U = UHMWPE	FBE = Flush Bottom Tank Flange	L = Lockable Extended Stem
1-1/4"		1 = Brass		P = PEEK	G = Grafoil	1 = 150RF Flange	D = Leak Detection Stem
1-1/2"				M = TFM™	E = Ethylene Propylene Rubber (EPR)	3 = 300RF Flange	GO = Gear Operator
2"						6 = 600RF Flange (1/2" - 2-1/2")	7 = 17-4PH Stem
2-1/2"							A = Nace
3"							
4"							

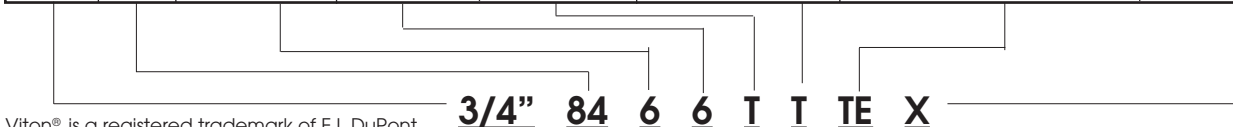

Viton® is a registered trademark of E.I. DuPont.
TFM is a registered trademark of Dyneon, LLC



A Division of Smith-Cooper International, LLC

Toll-Free 1-877-7SHARPE
(877) 774-2773
 Fax: (708) 562-9250
 E-Mail: info@sharpevalves.com
www.sharpevalves.com
 1260 Garnet Drive
 Northlake, Illinois 60164 U.S.A.