

SHARPE[®] VALVES

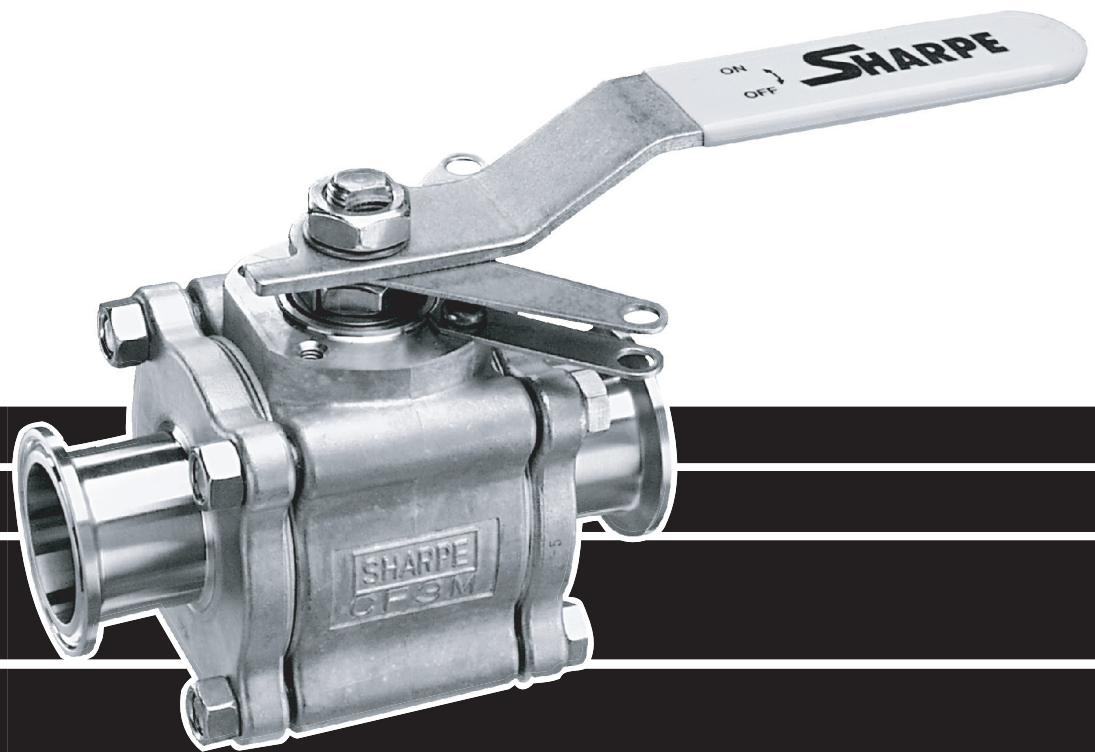

SERIES 66
HIGH PURITY TUBE FULL PORT
3 PIECE BALL VALVES

SERIES 66 VALVE PARTS AND IDENTIFICATION

1/2" - 2-1/2"

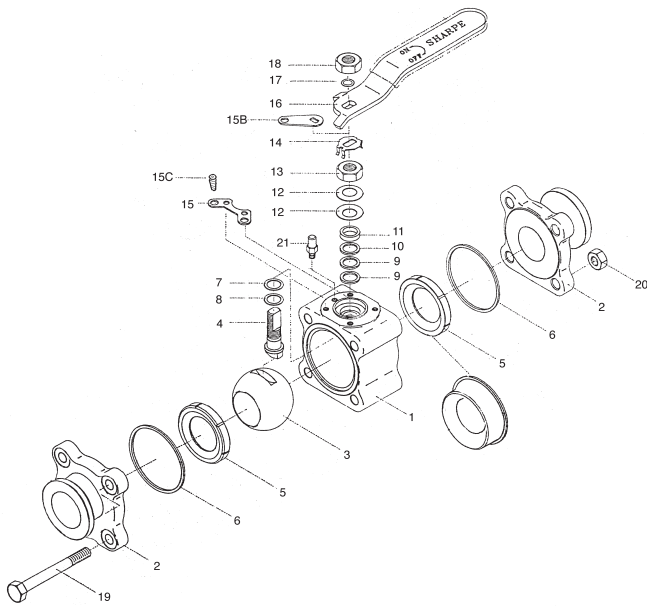

3" - 4"

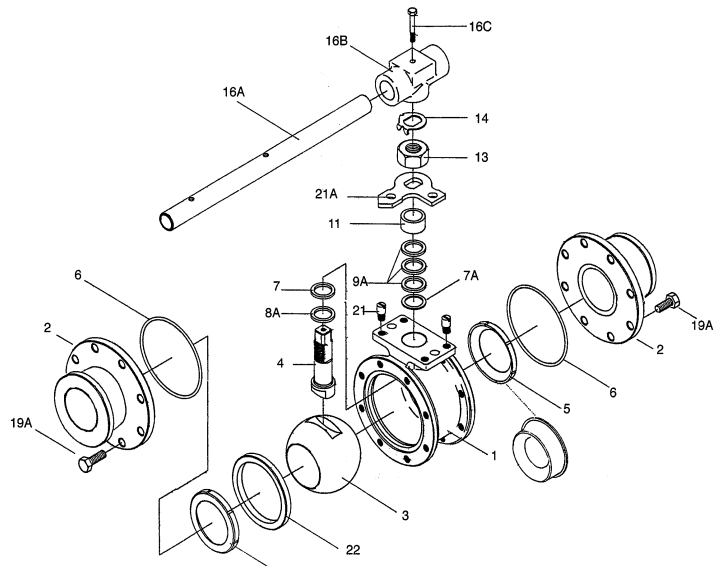

PART NO.	PART	QTY.	MATERIAL
1	Body	1	316L CF3M ASTM 351
2	Pipe Ends	2	316L (CE) ASTM 351 180 GRIT 316L (BE) ASTM A351 120 GRIT
3	Ball	1	316L
4	Stem	1	316L
5	Valve Seat	2	RTFE / Cavity Filler PTFE / PTFE-TFM
6	Valve Seal	2	PTFE PTFE-TFM
7	Thrust Bearing	1	Nova* / PTFE-TFM
7A	Stem Location Ring (3" & 4")	1	Stainless Steel
8	Thrust Bearing	1	Peek / PTFE-TFM
8A	Thrust Bearing	1	Nova* / PTFE-TFM
9	Stem Packing	2	Nova* / PTFE-TFM
9A	Stem Packing (3" & 4")	3	Nova* / PTFE-TFM
10	Seal Protector	1	Peek / PTFE-TFM
11	Gland Packing	1	Stainless Steel
12	Belleville Washer	2	Stainless Steel

* Nova: Carbon and Graphite Filled Teflon

PART NO.	PART	QTY.	MATERIAL
13	Packing Nut	1	Stainless Steel
14	Lock Tab	1	Stainless Steel
15	Lower Lock Latch	1	Stainless Steel
15B	Upper Lock Latch Bolt	1	Stainless Steel
15C	Latch Bolt	1	Stainless Steel
16	Handle (1/4"-2")	1	Stainless Steel
16A	Wrench (3" & 4")	1	Stainless Steel
16B	Wrench Block	1	Stainless Steel
16C	Hex Head Bolt	1	Stainless Steel
17	Lock Washer	1	Stainless Steel
18	Handle Nut (1/4"-2")	1	Stainless Steel
19	Body Bolts	4	Stainless Steel
19A	Body Connector Nut	8	Stainless Steel
20	Nuts	4	Stainless Steel
21	Stop Pin (1/4"-1/2")	1 2	Stainless Steel Stainless Steel
21A	Stopper	1	Stainless Steel
22	Seat Retainer	1	Stainless Steel

SERIES 66 VALVE DIMENSIONS

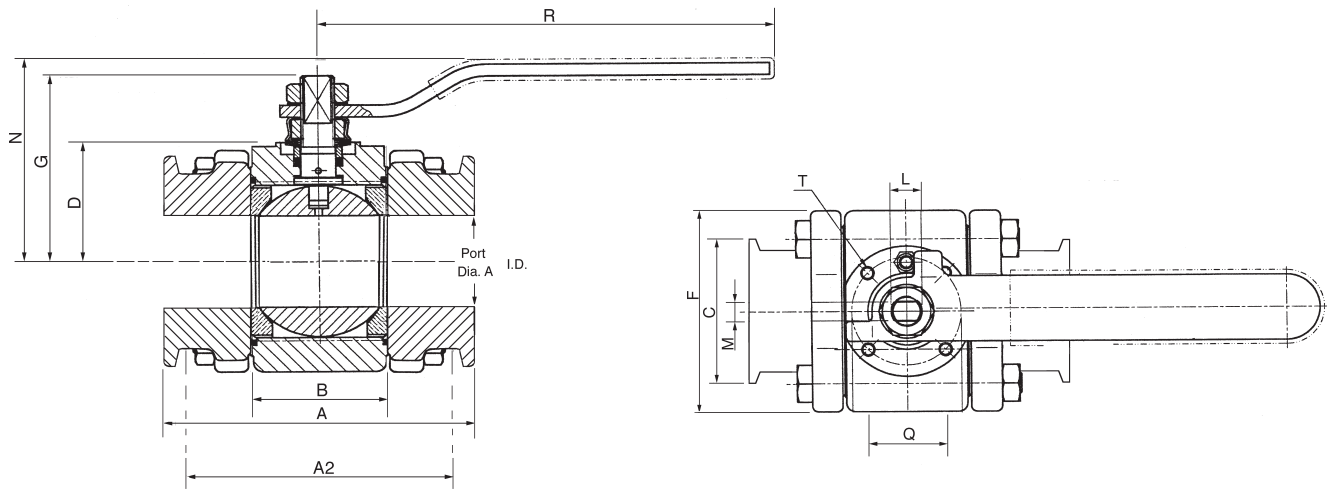

SIZE	A TR	A2	B	C	D	E	F	G	L	M	N	Q	R	T	V	PORT	O.D.	I.D.
1/2"	3.50	2.50	.97	1.25	.939	-	1.75	1.50	3/8" -24	.22	1.76	1.00	5.53	M5	.28	.37	.50	.37
3/4"	4.00	2.73	1.05	1.50	1.24	1.00	2.05	1.59	3/8" UNF	.22	1.87	1.00	4.50	M5	.28	.62	.75	.62
1"	4.50	3.62	1.54	1.75	1.51	1.18	2.42	2.19	7/16" UNF	.30	2.40	1.18	5.75	M5	.30	.87	1.00	.87
1-1/4"	4.50	4.12	1.75	2.00	1.65	1.18	2.70	2.38	7/16" UNF	.30	2.70	1.18	5.75	M5	.30	1.12	1.25	1.12
1-1/2"	5.50	4.47	2.13	2.25	1.71	1.38	3.16	2.88	9/16" UNF	.35	3.16	1.38	7.00	M6	.42	1.37	1.50	1.37
2"	6.25	4.90	2.66	2.62	1.87	1.38	3.56	3.06	9/16" UNF	.35	3.35	1.38	7.00	M6	.42	1.87	2.00	1.87

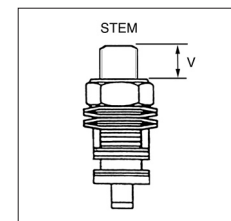
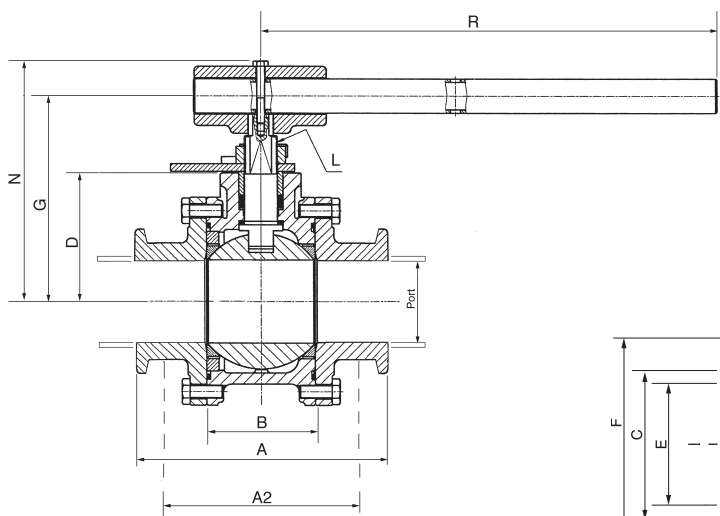

1/4" - 2-1/2"
STEM ARRANGEMENT
FOR ACTUATORS

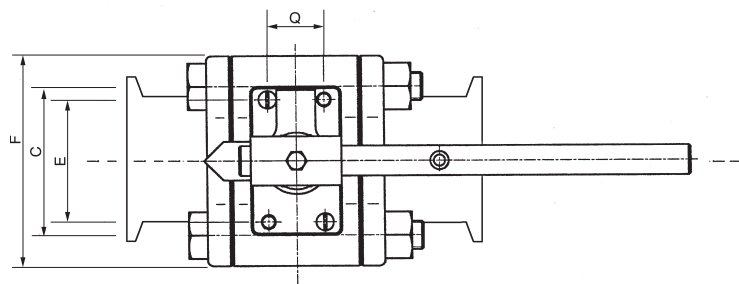

SIZE	A TR	A2	B	C	D	E	F	G	L	M	N	Q	R	T	V	PORT	O.D.	I.D.
2-1/2"	6.75	5.86	3.20	3.35	2.92	2.75	4.57	4.56	M20	.55	5.58	1.25	10.00	M8	.55	2.37	2.50	2.37
3"	6.75	6.66	3.96	5.50	3.87	3.38	6.44	7.25	1.14 UNS	.745	7.25	1.75	13.8	M10	.66	2.87	3.00	2.87
4"	8.25	8.40	4.75	6.97	4.48	3.38	8.12	7.84	1.14 UNS	.745	7.84	1.75	22.00	M10	.66	3.83	4.00	3.83

SHARPE® VALVES

PRESSURE TEMPERATURE DATA

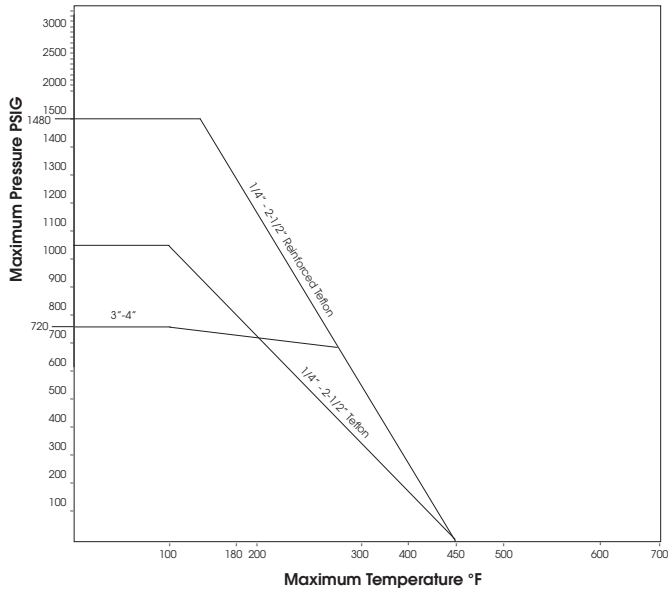

STEAM RATINGS*

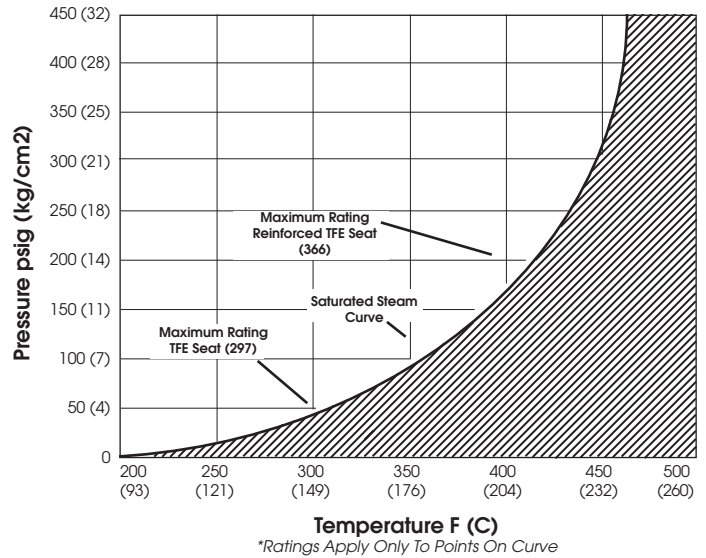

HOW TO ORDER

VALVE SIZE	VALVE SERIES	BODY & ENDS	BALL & STEM	SEAT	SEAL	ENDS	OPTIONS
1/2" 3/4" 1" 1-1/4" 1-1/2" 2" 2-1/2" 3" 4"	66	6-316L	6-316L	R = Reinforced Teflon® T = Teflon® C = Cavity Filler	Teflon®	CE = Clamp 180 GRIT BE = Buttweld 120 GRIT	X = Oxygen Service SF = Silicone Free OH = Oval Handle

3/4" 66 6 6 C CE SF

SHARPE® VALVES

A Division of Smith-Cooper International, LLC

Toll-Free 1-877-7SHARPE

(877) 774-2773

Fax: (708) 562-9250

E-Mail: info@sharpevalves.com

www.sharpevalves.com

1260 Garnet Drive

Northlake, Illinois 60164 U.S.A.