

# Pneumatic Actuator Type 3277



*Fig. 1 · Type 3277 Pneumatic Actuator*



*Fig. 2 · Type 3277-5 Pneumatic Actuator*

## **Mounting and Operating Instructions**

**EB 8311 EN**

Edition July 2006

### 1 Design and principle of operation

The **Type 3277** Pneumatic Actuators with an effective diaphragm area of 240, 350 or 700 cm<sup>2</sup> are primarily mounted to control valves from the Series 240, 250 and 280.

Type 3277-5 with a die-cast aluminum case and an effective diaphragm area of 120 cm<sup>2</sup>, is mounted to Type 3510 and Series 240 Valves.

The actuator is made up of two diaphragm cases, a rolling diaphragm and springs. The lower diaphragm case is permanently fixed to the yoke which allows the direct attachment of either a pneumatic or electropneumatic positioner or a limit switch.

Actuators with manual override (Fig. 5) additionally have a handwheel mounted on the diaphragm case. The handwheel moves the

actuator stem over a spindle after the locking mechanism (lock nut) has been disengaged. In addition, the actuator can be equipped in a special version with a mechanically adjustable travel stop.

The signal pressure creates a force at the diaphragm surface which is balanced by the springs (6) arranged in the actuator. The number of springs and their compression determine the bench range (signal pressure range) while taking the rated travel into account which is directly proportional to the signal pressure. A maximum of 30 springs can be installed, partly fitted inside one another.

The stem connector (16) connects the actuator stem (2) with the plug stem of the control valve.



- ▶ *Assembly, start-up and operation of the device may only be performed by trained and experienced personnel familiar with this product. According to these mounting and operating instructions, trained personnel is referred to individuals who are able to judge the work they are assigned to and recognize possible hazards due to their specialized training, their knowledge and experience as well as their knowledge of the relevant standards.*
- ▶ *Any hazards which could be caused by the signal pressure and moving parts of the actuator are to be prevented by means of appropriate measures.*
- ▶ *Proper shipping and appropriate storage are assumed.*

**Fail-safe action**

When the signal pressure fails, the fail-safe action of the actuator depends on whether the springs are installed in the top or bottom diaphragm chamber.

**Actuator stem extends**

When the signal pressure is reduced or the air supply fails, the springs move the actuator stem downwards and close the valve. The valve opens when the signal pressure is increased enough to overcome the force exerted by the springs.

**Actuator stem retracts**

When the signal pressure is reduced or the air supply fails, the springs move the actuator stem upwards and open the valve. The valve closes when the signal pressure is increased enough to overcome the force exerted by the springs.

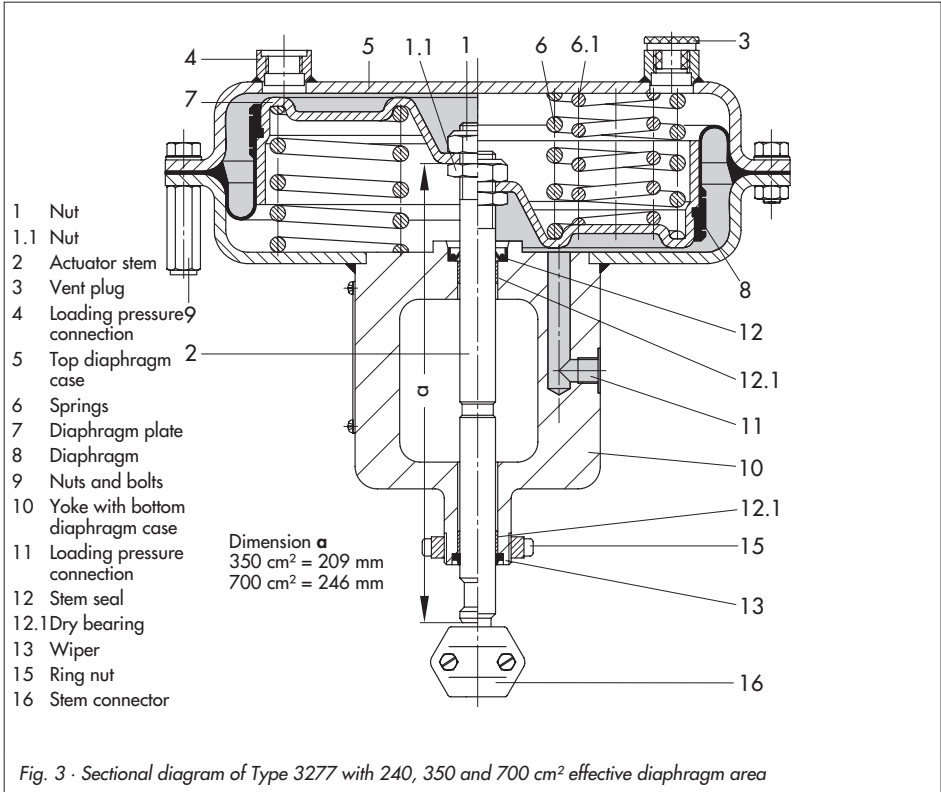

### Loading pressure connection

#### Type 3277 Actuator (Fig. 3)

In the Type 3277 Actuator with fail-safe action "Actuator stem extends", the loading pressure is connected to the loading pressure connection (11) at the side of the yoke to fill the bottom diaphragm chamber which causes the actuator stem (2) to move upwards. In an actuator with the fail-safe action "Actuator stem retracts", the loading pressure is connected the loading pressure connection (4) to fill the top diaphragm chamber which causes the actuator stem to move downwards.

#### Type 3277-5 Actuator (Fig. 4)

In the Type 3277-5 Actuator, the loading pressure is connected to a borehole either at the left or right of the yoke. A **switchover plate** (14, accessories) directs the air to one of the diaphragm chambers, depending on the fail-safe action of the actuator ("Actuator stem extends" or "Actuator stem retracts"), which is determined by how the plate is aligned with the mark (14.4).

- ▶ Turn the switchover plate to align the symbol (14.3) for the appropriate fail-safe action with the mark (14.4). See Fig. 4, bottom left. The operating direction (>>) or (<<) of the positioner determines whether the left or right attachment is to be used.

A **connecting plate** (accessories) is required instead of the switchover plate if the actuator is operated **without a positioner**. The loading pressure is directly connected to the loading pressure connection (14.8) of the connecting plate to fill the diaphragm chamber.

- ▶ Turn the connecting plate to align the symbol (14.3) for the appropriate fail-safe action "Actuator stem extends" or "Actuator stem retracts" with the mark (14.4). See Fig. 4, bottom right.
- ▶ Make sure that the flat gasket of the connecting plate is correctly inserted.
- ▶ The connecting plate has both NPT and G threaded bores. Seal the bore not required with a rubber gasket and square plug.

**Accessories:** The switchover plate or connecting plate must be ordered separately. Please note that actuators with modification index **01** e.g. 3277-531xxx20.**01** (old = **.00**) are equipped with new plates.

Old and new plates are not interchangeable.

		In- dex	Order no.
Switch- over plate	<b>New</b>	<b>01</b>	<b>1400-6822</b>
	Old	00	1400-6819
Con- necting plate	<b>New</b>	<b>01</b>	<b>1400-6823</b>
	Old: G thread	00	1400-6820
	Old NPT thread	00	1400-6821

**Note!** The pneumatic actuators are designed for a maximum supply pressure of 6 bar. To prevent the actuator from being damaged, do not let the supply pressure exceed the upper spring range value by more than 3 bar when the actuator is used for flow-switching service (on-off valve) with the fail-safe position "Actuator stem retracts". Label actuators that have a reduced supply pressure with a sticker "max. supply pressure limited to ... bar".

**Note!** Refer to the operating instructions of the corresponding valve on how to mount and remove the actuator from the valve.

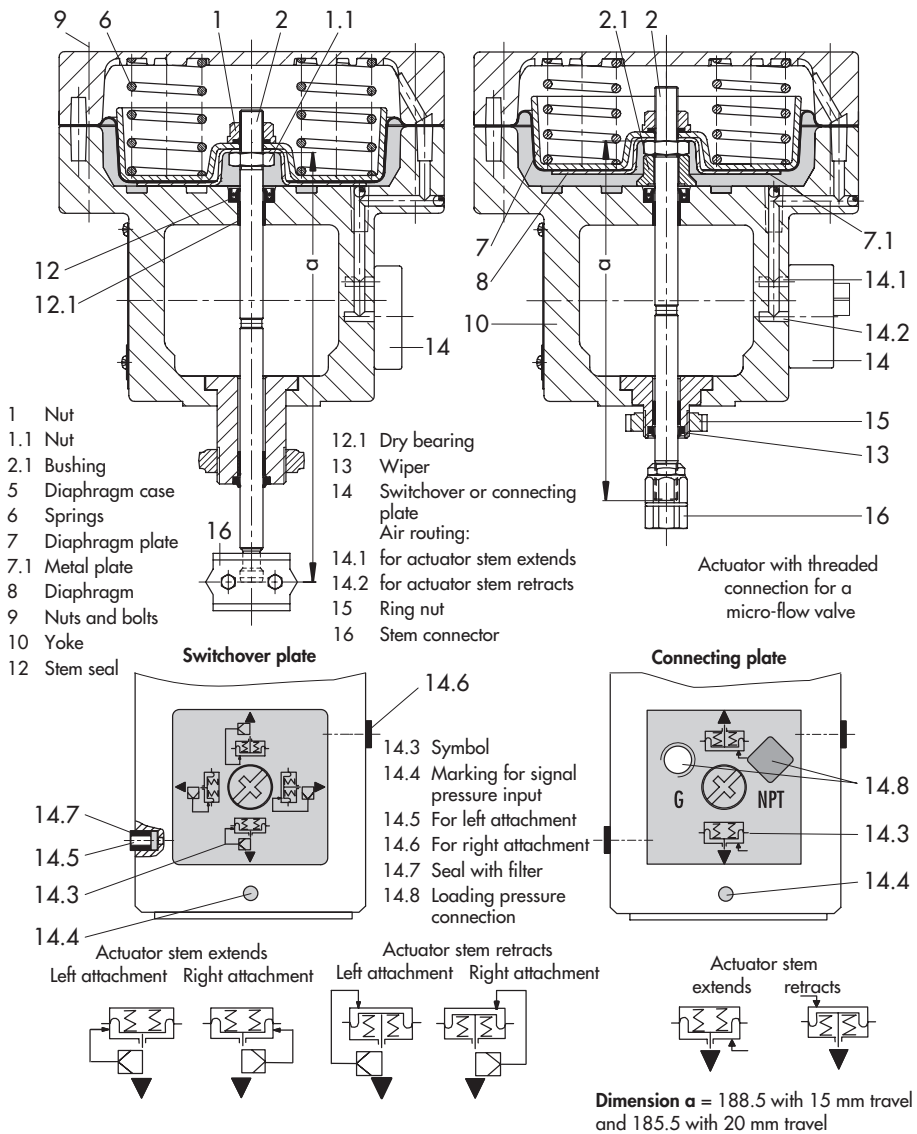

Fig. 4 · Type 3277-5 Actuators with 120 cm<sup>2</sup> effective diaphragm area

## 2 Operation

### Note!

*It is important for a trouble-free operation of the Type 3277 Actuator that the vent plug (3) is not blocked.*

*Make sure in versions with a handwheel that the plug stem can move freely when the valve is being positioned by the pneumatic actuator by moving the handwheel into a neutral position.*

### 2.1 Reversing the operating direction (fail-safe action)

The operating direction, i.e. fail-safe action, of pneumatic actuators can be changed. Prior to proceeding, you must remove the actuator from the valve.

The fail-safe action is represented by a symbol on the nameplate.



"Actuator stem extends"



"Actuator stem retracts"



### Caution!

*To disassemble an actuator with preloaded actuator springs (recognizable by the long bolts on the diaphragm chambers), always undo the short bolts first and then unthread the long bolts slowly and evenly until the actuator springs are fully decompressed.*

### 2.1.1 Standard actuator

#### Reversing the fail-safe action "Actuator stem extends" to "Actuator stem retracts"

### Note!

*Actuators with 700 cm<sup>2</sup> (travel = 30 mm) that are mounted to valves with 15 mm travel, are preloaded by approx. 75 % on mounting them to the valve.*

*The signal pressure range is recorded on the nameplate when the actuators have been preloaded on mounting them to the valve.*

1. Unthread nuts and remove the bolts (9) from the diaphragm cases.
2. Lift off the top diaphragm case (5) and remove the springs (6).
3. Pull the actuator stem (2) with diaphragm plate (7) and diaphragm (8) out of the yoke (10).
4. Unscrew nut (1), while holding the nut (1.1) stationary or clamping the actuator stem with a suitable tool.

**Caution!** Proceed carefully to avoid damaging the seals of the actuator stem.

**Caution!**

Do not loosen the nut (1.1) on the actuator stem. It is painted over to protect it. If, however, it has been loosened, it is essential that the dimension **a** (Figs. 3 and 4) measured from the top of the nut to the bottom of the actuator stem is kept.

5. Apply lubricant/sealant (order no. 8152-0043) to the sealing places on the actuator stem.
6. Turn over top diaphragm case (5). Place the actuator stem with diaphragm plate, diaphragm and metal plate (7.1), if applicable in the case.
7. Insert the springs (6) and slide the yoke with bottom diaphragm case over the actuator stem.
8. Screw tight the nuts and bolts of the diaphragm cases. Remove vent plug (3) in Type 3277 Actuator.

Proceed in the same manner for the **Type 3277-5** Actuator intended for the micro-valve, but additionally attach the bushing (2.1) for the mechanical travel stop.

The springs now press from below against the diaphragm plate and cause the actuator stem to retract (fail-safe action). The actuator stem only starts to extend when the signal pressure overcomes the force of the springs.

9. Record the changed fail-safe action on the nameplate!

**Reversing the fail-safe action "Actuator stem retracts" to "Actuator stem extends"**

1. Unthread nuts and remove the bolts (9) and lift off the top diaphragm case (5).
2. Pull the actuator stem with diaphragm plate, diaphragm and metal plate (7.1), if applicable the diaphragm plate (7) out of the yoke and bottom diaphragm case (10).
3. Unscrew nut (1), while holding the nut (1.1) stationary or clamping the actuator stem with a suitable tool.  
**Caution!** Proceed carefully to avoid damaging the seals of the actuator stem.
4. Remove the diaphragm plate with diaphragm and replace them in reverse order. Screw tight nut (1).
5. Coat the sealing parts of the actuator stem with sealant/lubricant (order no. 8152-0043).
6. Insert the actuator stem with diaphragm plate, diaphragm and metal plate (7.1), if applicable, into the bottom diaphragm case with yoke.
7. Insert springs (6) and place the top diaphragm case back on. Screw tight the nuts and bolts of the diaphragm cases.
8. Screw the vent plug (3) into the top loading pressure connection of the Type 3277 Actuator.

Proceed in the same manner for the **Type 3277-5** Actuator intended for the micro-valve, but additionally attach the bushing (2.1) for mechanical travel stop.

The springs now press from the top against the diaphragm plate and cause the actuator stem to extend (fail-safe action). The actua-

tor stem only starts to retract when the signal pressure overcomes the force of the springs.

9. Record the changed fail-safe action on the nameplate!

### 2.1.2 Actuator with handwheel

Type 3277 (Fig. 5) only

1. Undo lock nut (20) and relieve the springs (6) by turning the handwheel (17).
2. Loosen threaded pin (26) and unscrew coupling nut (25) from the coupling (22).
3. Knock out the clamping sleeve (23) and remove the ring (24).
4. Unthread the ring nut (15) and lift off the flange part (21) together with the coupling nut (25).

### Reversing the fail-safe action "Actuator stem extends" to "Actuator stem retracts"

- ▶ Proceed as described in section 2.1.1. However, use the word "spindle with nut (27)" in place of "nut (1)".

After reversing the operating direction:

1. Replace the flange part (21) with ring nut (15) and coupling nut (25).
2. Tighten ring nut (15). Attach the ring (24) with clamping sleeve (23).
3. Screw coupling nut (25) as far as it will go onto the coupling (22) and secure with threaded pins (26).

### Reversing the fail-safe action "Actuator stem retracts" to "Actuator stem extends"

- ▶ Proceed as described in section 2.1.1. However, use the word "spindle with nut (27)" in place of "nut (1)".

After reversing the operating direction:

1. Replace the flange part (21) with ring nut (15) and coupling nut (25).
2. Tighten ring nut (15). Attach the ring (24) with clamping sleeve (23). Attach the ring (24) with clamping sleeve (23).
3. Screw coupling nut (25) as far as it will go onto the coupling (22) and secure with threaded pins (26).

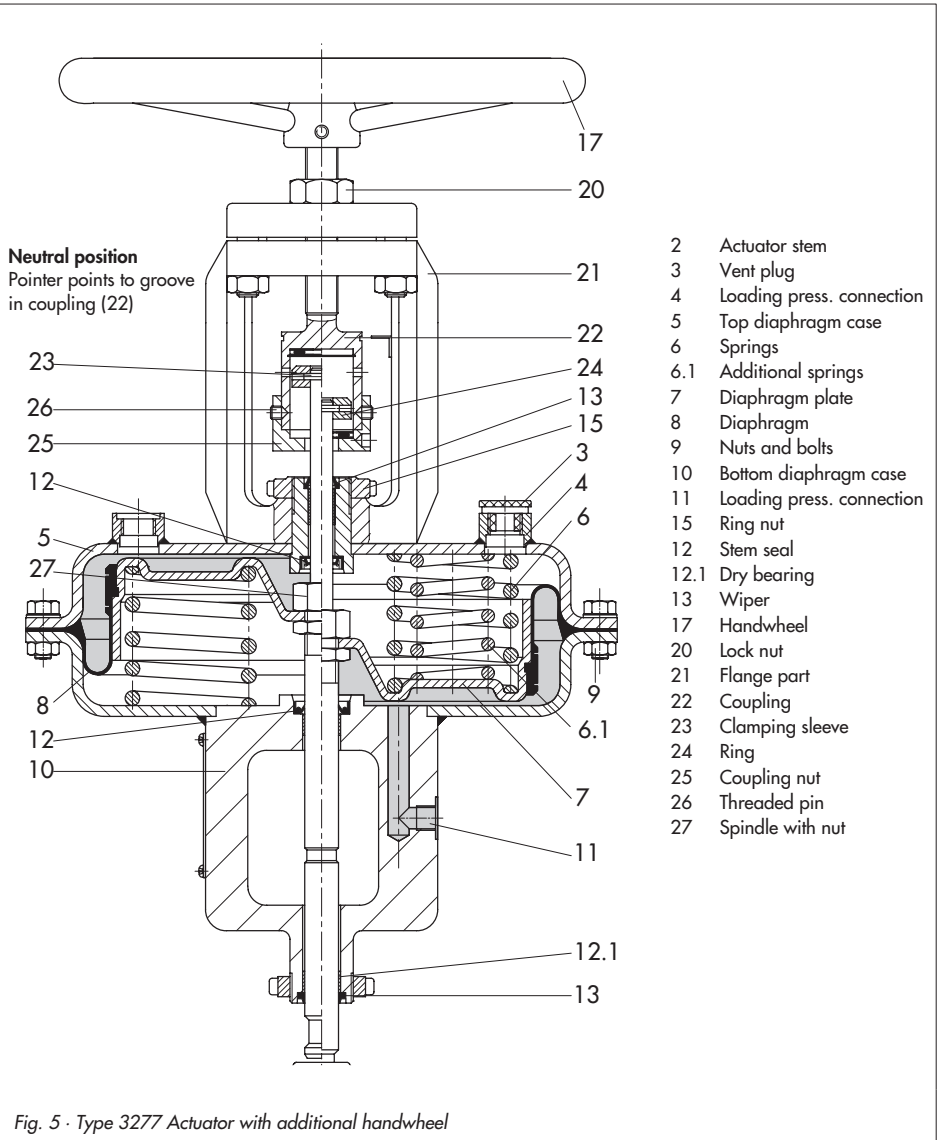

### 2.2 Adjusting the travel stop

(with Type 3277 in special version only)

The travel stop can be adjusted upwards or downwards to 50% of the travel.

#### Downward travel stop

(actuator stem extends)

1. Undo the lock nut (34) and unscrew the cap (33).
2. Undo the lock nut (31) and adjust the nut (32) to set required travel stop.
3. Tighten the lock nut (31) again.

#### Upward travel stop

(actuator stem retracts)

1. Undo the lock nut (34) and adjust the cap (33) to set the required travel stop.
2. Tighten the lock nut (34) again.

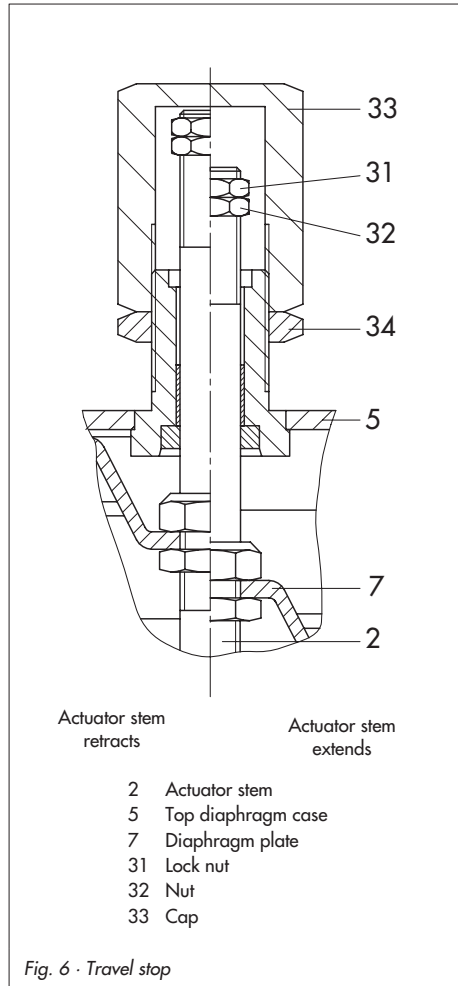

### 3 Replacing the diaphragm and stem seal

#### 3.1 Diaphragm

(Fig. 3)

1. Remove the diaphragm plate (7) together with diaphragm (8) and actuator stem (2) from the diaphragm case as described in section 2.1.1.
2. Remove the hose clamp and pull it together with the diaphragm (8) off the diaphragm plate (7) (not necessary with Type 3277-5 as the diaphragm is held in place by the metal plate (7.1)).
3. Stretch the new diaphragm onto the diaphragm plate. Fit the hose clamp evenly into the groove intended for it and tighten.
4. Reassemble actuator as described in section 2.1.1.

#### 3.2 Stem seal

1. Remove the diaphragm plate (7) together with the actuator stem (2) from the diaphragm case as described in section 2.1.1.
2. Coat the new stem seal (12) with lubricant/sealant (order no. 8152-0043) and insert it.
3. If necessary, replace the dry bearing (12.1) and wiper (13) with new ones as well.
4. Reassemble the actuator as described in section 2.1.1.

### 4 Customer inquiries

Please specify the following details on making inquiries:

- ▶ Type and model number
- ▶ Effective diaphragm area
- ▶ Bench range (spring range) in bar
- ▶ Actuator version and its operating direction

#### **Dimensions and weights**

Refer to the Data Sheet T 8310-1 EN dimensions and weights of the different actuator versions.

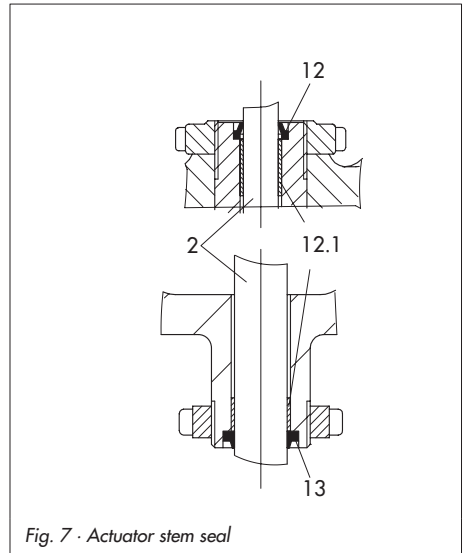

Fig. 7 · Actuator stem seal



SAMSON AG · MESS- UND REGELTECHNIK  
Weismüllerstraße 3 · 60314 Frankfurt am Main · Germany  
Phone: +49 69 4009-0 · Fax: +49 69 4009-1507  
Internet: <http://www.samson.de>

**EB 8311 EN**

S/Z 2006-08