

# Pneumatic Control Valves Type 3241-1 and Type 3241-7

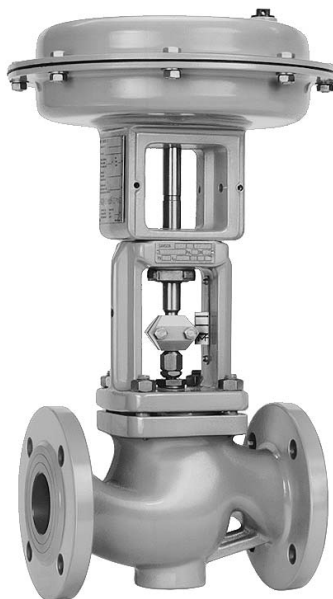

Type 3241-1



Type 3241-7

*Fig. 1 · Type 3241 Valve with Type 3271 Actuator and with Type 3277 Actuator*

## Mounting and Operating Instructions

**EB 8015 EN**

Edition July 2007



Contents	Page
<b>1</b>	<b>Design and principle of operation</b> . . . . . 4
<b>2</b>	<b>Assembling valve and actuator</b> . . . . . 4
2.1	Assembly and adjustment . . . . . 4
2.2	Pretensioning springs in actuator version "Actuator stem extends". . . . . 7
2.3	Valve and actuator with different rated travels . . . . . 8
<b>3</b>	<b>Installation</b> . . . . . 9
3.1	Mounting position . . . . . 9
3.2	Signal pressure line. . . . . 9
3.3	Strainer, bypass . . . . . 9
3.4	Test connection . . . . . 9
<b>4</b>	<b>Operation</b> . . . . . 9
<b>5</b>	<b>Maintenance – Replacing parts</b> . . . . . 10
5.1	Standard valve version . . . . . 11
5.1.1	Stuffing box packing . . . . . 11
5.1.2	Seat and/or plug . . . . . 12
5.2	Valve with insulating section or metal bellows seal . . . . . 13
5.2.1	Stuffing box packing . . . . . 13
5.2.2	Plug . . . . . 13
5.2.3	Seat . . . . . 15
5.2.4	Metal bellows . . . . . 15
5.2.5	Reassembly . . . . . 16
5.3	Replacing the collar or seal . . . . . 16
<b>6</b>	<b>Material identifying marks</b> . . . . . 18
<b>7</b>	<b>Description of nameplates</b> . . . . . 19
<b>8</b>	<b>Customer inquiries</b> . . . . . 19

These Mounting and Operating Instructions apply also to **Type 3246 Globe Valve** (Class 150 and 300) in conjunction with Data Sheet T 8046-1 EN.

**Note!**

*Non-electrical control valves which do not have a valve body lined with an insulating material coating do not have their own potential ignition source according to the risk assessment in the rare incident of an operating fault, corresponding to EN 13463-1: 2001 paragraph 5.2, and therefore do **not** fall within the scope of the European Directive 94/9/EC. Refer to paragraph 6.3 of EN 60079-14:1977 VDE 0165 Part 1 concerning connection to equipotential bonding system.*



### General safety instructions

- ▶ *The control valve may only be mounted, started up or serviced by fully trained and qualified personnel, observing the accepted industry codes and practices. Make sure employees or third persons are not exposed to any danger. All safety instructions and warnings in these mounting and operating instructions, particularly those concerning assembly, start-up and maintenance, must be observed.*
- ▶ *The control valves fulfill the requirements of the European Pressure Equipment Directive 97/23/EC. Valves with a CE marking have a declaration of conformity that includes information about the applied conformity assessment procedure. The declaration of conformity is available on request.*
- ▶ *For appropriate operation, make sure that the control valve is only used in areas where the operating pressure and temperatures do not exceed the operating values which are based on the valve sizing data submitted in the order. The manufacturer does not assume any responsibility for damage caused by external forces or any other external influence! Any hazards which could be caused in the control valve by the process medium, operating pressure, signal pressure or by moving parts are to be prevented by means of the appropriate measures.*
- ▶ *Proper shipping and appropriate storage are assumed.*

### Caution!

- ▶ *For installation and maintenance work on the valve, make sure the relevant section of the pipeline is depressurized and, depending on the process medium, drained as well. If necessary, allow the control valve to cool down or warm up to reach ambient temperature prior to starting any work on the valve.*
- ▶ *Prior to performing any work on the valve, make sure the supply air and control signal are disconnected or blocked to prevent any hazards that could be caused by moving parts.*
- ▶ *Special care is needed when the actuator springs are pretensioned. These actuators are labeled correspondingly and can also be identified by three long bolts at the bottom of the actuator. Prior to starting any work on the valve, you must relieve the compression from the pretensioned springs.*

# 1 Design and principle of operation

The Type 3241-1 and Type 3241-7 Pneumatic Control Valves consist of a Type 3241 single-seated Globe Valve and either a Type 3271 or Type 3277 Pneumatic Actuator.

Thanks to the modular design, the actuators can be exchanged, and the standard version of the valve can be supplemented to form a version with insulating section or metal bellows seal.

In the **micro-flow valve** version, a micro-trim element is installed in the valve body instead of the usual seat-plug assembly.

The process medium flows through the valve in the direction indicated by the arrow. The position of the plug (3) determines the flow through the valve seat (2). The position of the plug (3) is changed by the signal pressure acting on the diaphragm of the actuator (bench range). Plug (3) and actuator stem (8.1) are connected via the stem connector (7) and sealed by the spring-loaded ring packing (4.2).

## Fail-safe position

The control valve provides two different fail-safe positions depending on the arrangement of the springs in the actuator:

### Actuator stem extends

When the signal pressure is reduced or the power supply fails, the springs move the actuator stem downwards and close the valve. When the signal pressure increases again, the valve opens acting against the force of the springs.

### Actuator stem retracts

When the signal pressure is reduced or the power supply fails, the springs move the actuator stem upwards and open the valve. When the signal pressure increases again, the valve closes acting against the force of the springs.

## 2 Assembling valve and actuator

The basic pneumatic actuator can be replaced by an electric actuator or a pneumatic actuator with additional handwheel.

A pneumatic actuator (with or without handwheel) can be exchanged for another pneumatic actuator in a different size.

If, in the valve-actuator assembly, the travel range of the actuator is larger than the travel range of the control valve, the actuator springs are preloaded by the manufacturer so that the travels match.

### 2.1 Assembly and adjustment

If the valve and actuator have not been pre-assembled by the manufacturer, or if the actuator of a control valve is to be replaced by an actuator of another type or another size, proceed as described below.

1. Unscrew the lock nut (6.2) and stem connector nut (6.1).  
Firmly press the plug together with the plug stem into the seat ring. Thread the stem connector nut and lock nut downwards.
2. Remove the stem connector clamps (7) and the ring nut (8.2) from the actuator (8). Slide the ring nut over the plug stem.

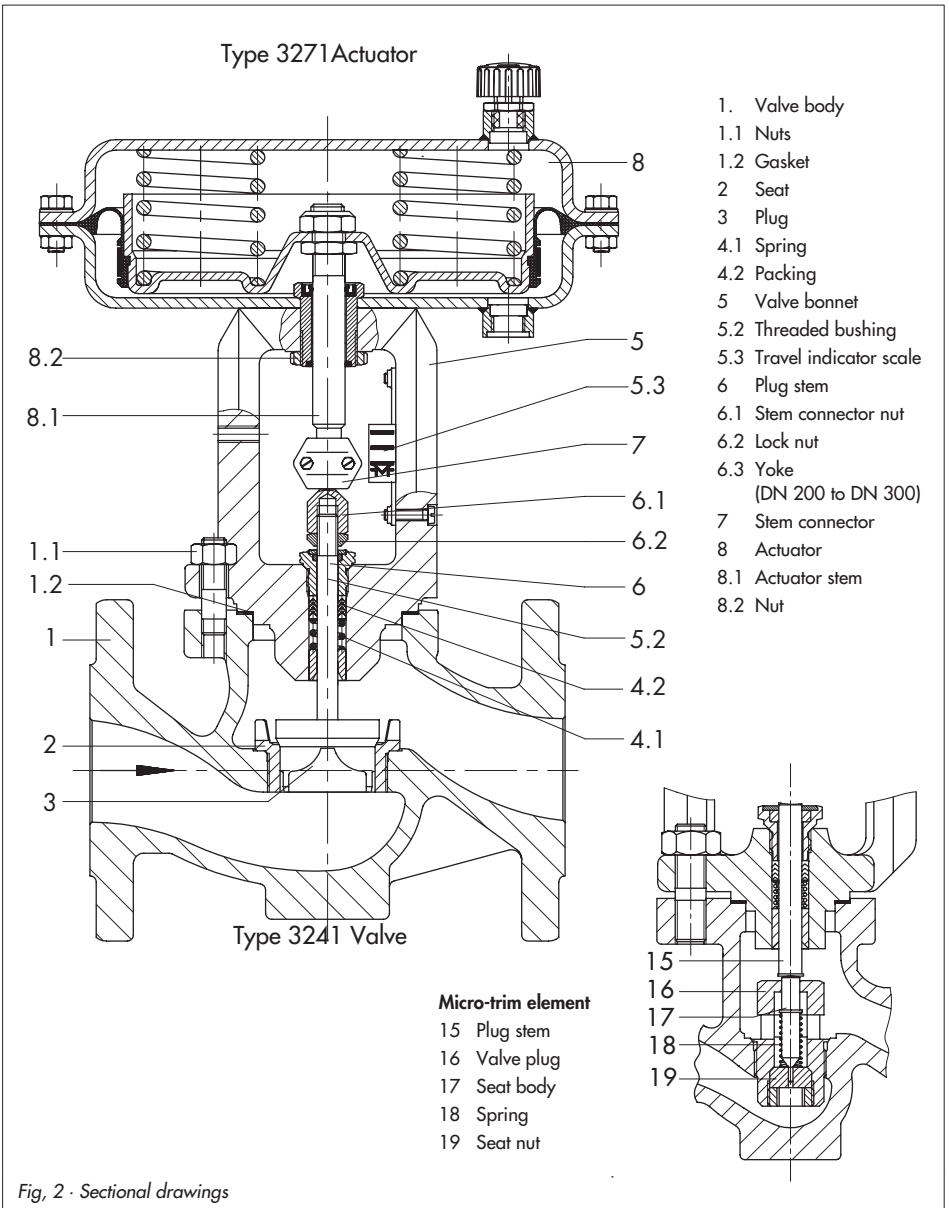

Fig. 2 · Sectional drawings

Type 3277 Actuator

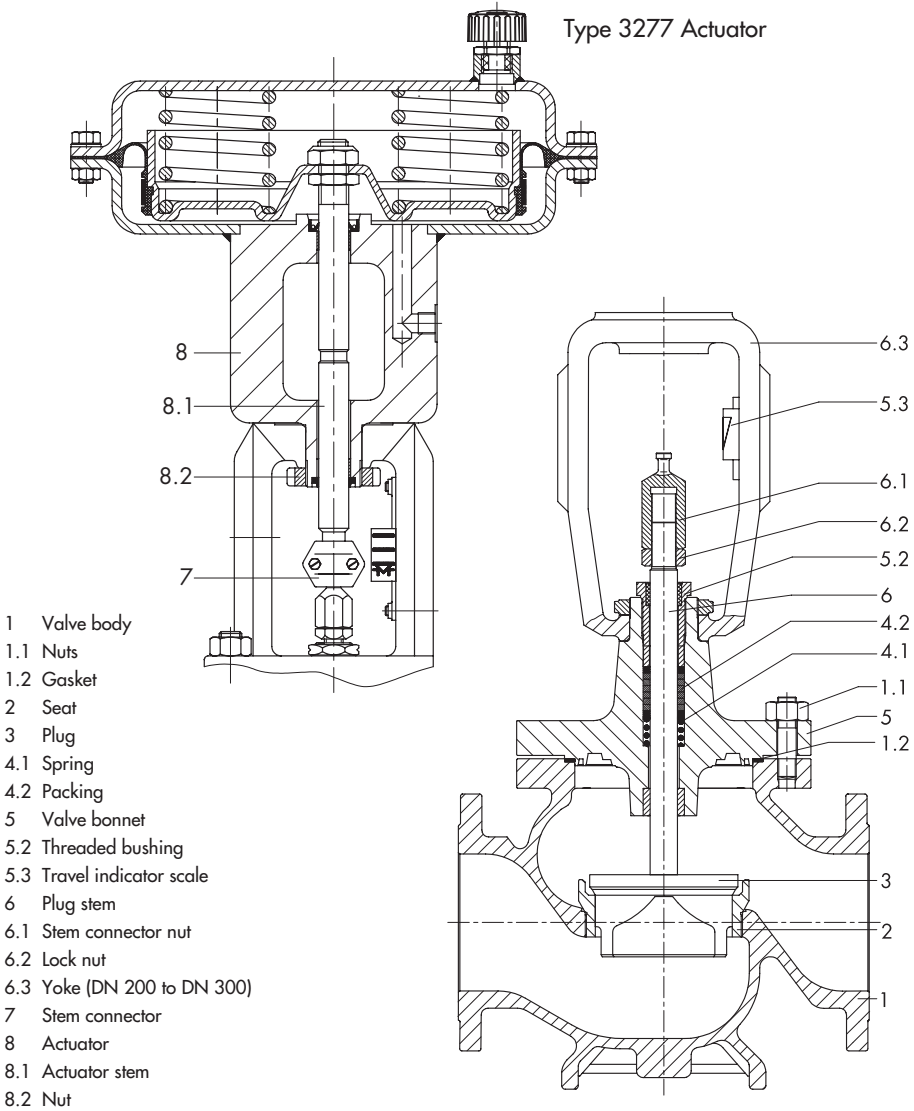

Fig. 3 · Sectional drawings of Type 3241-7 and valve body DN 200 to DN 300

3. Place actuator onto the valve bonnet (5) and secure with the ring nut (8.2).
4. Read bench range (or bench range with pre-loaded springs) and fail-safe action from the actuator's nameplate (e.g. 0.2 to 1 bar and "Actuator stem extends").

The lower value of the bench range (0.2 bar) corresponds to the lower bench range value to be adjusted; the upper bench range value (1 bar) corresponds to the upper bench range value. The fail-safe action "Actuator stem extends" (FA) or "Actuator stem retracts" (FE) is indicated on the Type 3271 Actuator. The Type 3277 Actuator bears the corresponding symbol.

5. For actuators with "Actuator stem extends", apply a signal pressure to the lower diaphragm chamber which corresponds to the lower bench range value (e.g. 0.2 bar).

For actuators with "Actuator stem retracts", apply a signal pressure to the upper diaphragm chamber which corresponds to the upper bench range value (e.g. 1 bar).

6. Thread down the stem connector nut (6.1) by hand until it makes contact with the actuator stem (8.1). Then, turn it another 1/4 turn and secure this position with the lock nut (6.2).
7. Position the stem connector clamps (7) and screw tight. Align the travel indicator scale (5.3) with the tip of the stem connector.

---

### **Note on disassembling an actuator!**

*Before disassembling an actuator with fail-safe action "Actuator stem extends" and particularly an actuator with pretensioned springs, apply a pressure to the lower signal pressure connection that slightly exceeds the lower bench range value (see nameplate of the actuator), so that you can loosen the ring nut (8.2).*

---

## **2.2 Pretensioning springs in actuator version "Actuator stem extends"**

To achieve a greater positioning force, the springs in actuators with "Actuator stem extends" can be preloaded with up to 12.5 % (actuator sizes 120 and 240 cm<sup>2</sup>) or up to 25 % (350 cm<sup>2</sup> and higher) of their travel or bench range.

### **Example:**

If the springs are preloaded with, for example, 0.1 bar for a bench range of 0.2 to 1 bar, the bench range is shifted by 0.1 bar to result in a bench range of 0.3 to 1.1 bar (0.1 bar corresponds to a preload of 12.5 %).

When adjusting the valve, the lower bench range is to be set to 0.3 bar. Make sure the new bench range of 0.3 to 1.1 bar is indicated on the nameplate as the bench range with pretensioned springs!

## 2.3 Valve and actuator with different rated travels

### Actuator version "Actuator stem extends"

---

**Note!**

*Valves that have a travel smaller than the rated travel of the actuator always need to use pretensioned springs.*

---

**Example:**

Valve DN 100 with 30 mm rated travel and 1400 cm<sup>2</sup> actuator with 60 mm rated travel, 0.4 to 2 bar bench range.

1. Set the signal pressure required for tensioning the springs above the signal pressure of 1.2 bar (1.2 to 2 bar range) which corresponds to the mid actuator travel (30 mm) to 1.6 bar.
2. Thread stem connector nut (6.1) until it touches the actuator stem.
3. Secure the position with lock nut and attach stem connector as described in section 2.1.
4. Enter the 1.6 to 2.4 bar bench range valid for the mounted valve on the nameplate of the actuator.

### Actuator version "Actuator stem retracts"

---

**Caution!**

*The springs in the actuator version "Actuator stem retracts" cannot be pretensioned!*

---

If a valve is to be attached to a larger actuator (rated travel of actuator larger than the rated travel of the valve), just the first half of the bench range of the actuator can be used.

**Example:**

Valve DN 100 with 30 mm rated travel and 1400 cm<sup>2</sup> actuator with 60 mm rated travel, 0.4 to 1 bar bench range:

A useable bench range of 0.2 to 0.6 bar is available for the half valve range.

---



**Note!**

*Actuators which have been preloaded by the manufacturer without an attached valve are marked with a label. In addition, you will notice three extended bolts on the bottom diaphragm case. They enable you to evenly relieve the preload of the springs when disassembling the actuator.*

---

## 3 Installation

### 3.1 Mounting position

The valve can be mounted in any desired position. However, vertical installation with the actuator pointing upwards is preferable for valves in nominal size DN 100 or larger to facilitate maintenance.

For valves with insulating section or metal bellows seal, or for actuators weighing more than 50 kg, mount a suitable support or suspension for the actuator.

#### **Note!**

*The valve must be installed with the least amount of vibrations possible and without any stress.*

#### **Piping design**

*To allow the control valve to work properly, the pipeline upstream and downstream of the valve should be straight and free of obstructions for a length of at least 6 times the pipe diameter (DN).*

*Contact SAMSON if this length cannot be met during installation.*

*Clean out the pipeline thoroughly prior to installing the valve.*

#### **Note!**

*Valves that should meet the requirements of NACE MR 0175 standard should not be insulated.*

### 3.2 Signal pressure line

Connect the signal pressure line to the lower diaphragm case for valves with actuator version "Actuator stem extends" and to the upper diaphragm case for valves with actu-

ator version "Actuator stem retracts".

The lower signal pressure connection of the Type 3277 Actuator is located at the side of the yoke of the lower diaphragm case.

### 3.3 Strainer, bypass

We recommend you to install a SAMSON Type 2 Strainer upstream of the valve body. We also recommend to install a shut-off valve both upstream of the strainer and downstream of the valve, as well as a bypass, so that you do not need to shut down the plant for maintenance.

### 3.4 Test connection

If there is a test connection (G 1/8) at the upper flange of a valve version with metal bellows seal (Fig. 6), you can check the tightness of the bellows there.

Particularly for liquids and vapors, we recommend you to install a suitable leak indicator at the test connection, such as a contact pressure gauge, an outlet into an open vessel or an inspection window.

## 4 Operation

(e.g. reversing the fail-safe action of the actuator etc.)

For details concerning operation, see Mounting and Operating Instructions EB 8310 EN for the Type 3271 Pneumatic Actuator and EB 8311 EN for the Type 3277 Pneumatic Actuator.

## 5 Maintenance – Replacing parts

The control valve is subject to natural wear, especially at the seat, plug and packing. Depending on the application, the valve needs to be checked regularly to prevent against possible failures.

If leakage occurs, this could be caused by a damaged packing or a defective metal bellows.

If the valve does not seal properly, the tight shut-off may be impeded by dirt or other impurities caught between the seat and plug, or by damaged seating surfaces.

Remove the parts, clean them thoroughly and replace them with new ones, if necessary.



### **Note!**

*Before servicing or disassembling the control valve, depressurize the concerned section of the plant and drain it, if necessary, depending on the medium used. Switch off the signal pressure for the actuator and remove the signal pressure line. As valves are not free of cavities, there might still be residual medium in the valve. This applies, in particular, for valve versions with insulating section and metal bellows seal.*

---

---

### **Caution!**

*On performing any work on the valve, first shut off the signal pressure, disconnect the signal pressure line and remove the actuator.*

### **Note!**

*Suitable seat and special tools as well as the appropriate tightening torques required for installation are listed in EB 029 EN (formerly WA 029 EN). The instructions can be viewed on the Internet at [www.samson.de/pdf\\_en/e00290en.pdf](http://www.samson.de/pdf_en/e00290en.pdf).*

---

### **Removing the actuator:**

1. Before disassembling an actuator with fail-safe action "Actuator stem extends" and particularly an actuator with preloaded springs, apply a pressure to the lower signal pressure connection that slightly exceeds the lower bench range value (see nameplate), so that you can remove the ring nut (8.2). Remove the stem connector clamps (7) and the ring nut (8.2).
2. Remove the actuator from the valve bonnet.

## 5.1 Standard valve version

### 5.1.1 Stuffing box packing

1. Remove the body nuts (1.1) as well as the valve bonnet (5) together with the plug stem and plug from the body.
2. Unscrew the stem connector nut and lock nut (6.1 and 6.2) from the plug stem.
3. Screw the threaded bushing (5.2) out of the stuffing box. Pull the plug stem together with the plug out of the valve bonnet.
4. Pull all packing parts out of the packing chamber using a suitable tool. Replace damaged parts. Clean packing chamber thoroughly.
5. Remove the gasket (1.2) and carefully clean sealing faces in the valve body and on the bonnet.
6. Apply lubricant (order no. 8150-0111) to all the packing parts and the plug stem (6).
7. Slide the plug stem with plug into the valve bonnet.

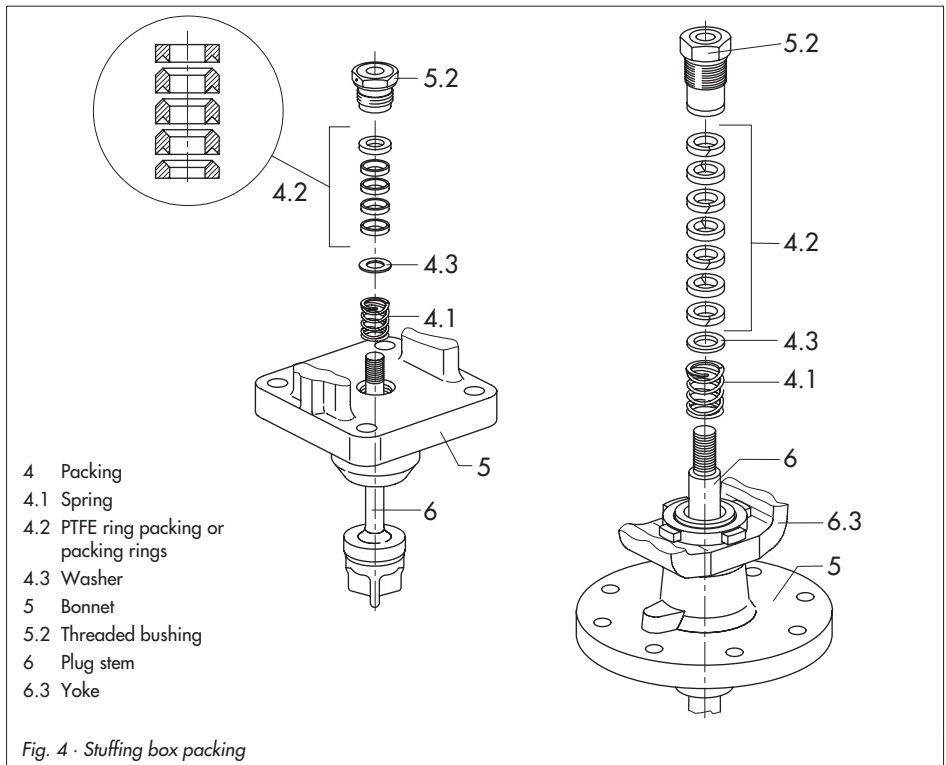

8. Insert new flat gasket (1.2) into the body. Carefully place the valve bonnet onto the valve body and secure with nuts (1.1).
9. Carefully slide the stuffing box parts over the plug stem into the packing chamber. Make sure to keep the proper order. Screw in the threaded bushing (5.2) and tighten.
10. Loosely screw the lock nut (6.2) and stem connector nut (6.1) onto the plug stem.
11. Mount the actuator and adjust the upper and lower bench range values as described in section 2.1.

12 mm. For seat bores of 63 mm and larger, the entire sealing ring can be exchanged, if necessary (the plug parts are screwed together).

### 5.1.2 Seat and/or plug

We recommend you to also replace the packing (4.2) when exchanging the seat and plug.

To exchange the packing, proceed as described in section 5.1.1.

#### Plug:

- ▶ Remove the old plug and replace it with a new plug with plug stem. It is possible to use the old plug again, provided it has been reworked properly. Apply lubricant (order no. 8150-0111) to the plug stem before installation.

#### Reworking the plug

- ▶ Slight damage at the sealing edges of the plug can be eliminated by re-turning it on a lathe. Soft-sealing plugs can only be reworked until dimension x is reached, and if the seat bore exceeds

#### Seat:

- ▶ Unscrew the seat (2) using the appropriate seat wrench (see EB 029 EN). Apply lubricant (order no. 8150-0119) to the thread and sealing cone of the new seat (or possibly the old seat when it has been reworked or thoroughly cleaned) and screw it in.

#### Micro-trim insert

In this version, the complete micro-trim element (Fig. 2) can be unscrewed from the valve body using a socket wrench (width across flats 27) and disassembled for cleaning. If individual parts are damaged, exchange the entire micro-trim element.

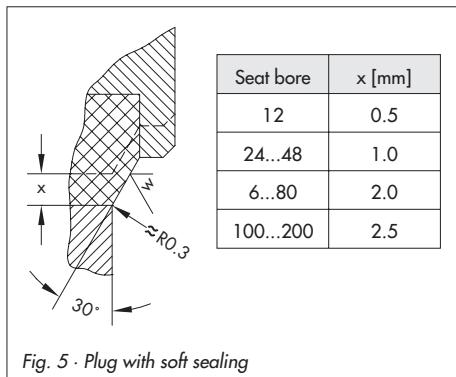

Fig. 5 · Plug with soft sealing

## 5.2 Valve with insulating section or metal bellows seal

### 5.2.1 Stuffing box packing

1. Remove the stem connector nut and lock nut (6.1 and 6.2) from the plug stem extension (6.3). Unscrew the threaded bushing (5.2) out of the stuffing box.
2. Remove nuts (5.4) and carefully lift the bonnet (5) over the plug stem extension.
3. Pull all stuffing box parts out of the packing chamber using a suitable tool. Replace damaged parts. Clean packing chamber thoroughly.
4. Remove the gasket (5.5) in the intermediate piece (12) and carefully clean the sealing faces.
5. Apply lubricant (order no. 8150-0111) to all the packing parts and the plug stem (6).
6. Insert new gasket (5.5) in the intermediate piece. Carefully place the bonnet over the plug stem extension onto the bonnet and secure with nuts (5.4).
7. Carefully slide the stuffing box parts over the plug stem extension into the packing chamber. Make sure to keep the proper order. Screw in the threaded bushing (5.2) and tighten.
8. Loosely screw the lock nut (6.2) and stem connector nut (6.1) onto the plug stem.
9. Mount the actuator and adjust the upper and lower bench range values as described in section 2.1.

### 5.2.2 Plug

When exchanging the plug, check the packing (4.2) or, preferably, replace it as described in section 5.2.1.

Nominal sizes **DN 15 to DN 150**: To unscrew the plug (6) from the plug stem extension (6.3), screw two nuts onto the protruding thread of the extension to hold the plug stem extension in place.

---

#### **Caution!**

*To prevent damage to the version with the bellows seal (no bellows in the version with insulating section), make sure no torque is transmitted to the bellows, which is connected to the intermediate piece. We recommend you to use a clamping tool (see EB 029 EN).*

---

1. Remove the nuts (1.1).
2. Remove the intermediate piece (12) together with the plug stem extension, plug stem and plug from the valve body.
3. Remove gasket (1.2) and carefully clean the sealing faces in the valve body and on the intermediate piece.
4. Use an appropriate wrench to hold the nuts stationary, which are screwed onto the plug stem extension. Clamp the plug stem using a suitable tool and screw it out of the plug stem extension.  
**Caution!** Do not twist the plug stem extension with the welded-on bellows!
5. Apply lubricant (order no. 8150-0111) to the end of the plug stem (6) of the new or old, reworked plug (3). Check whether the two washers (6.4)

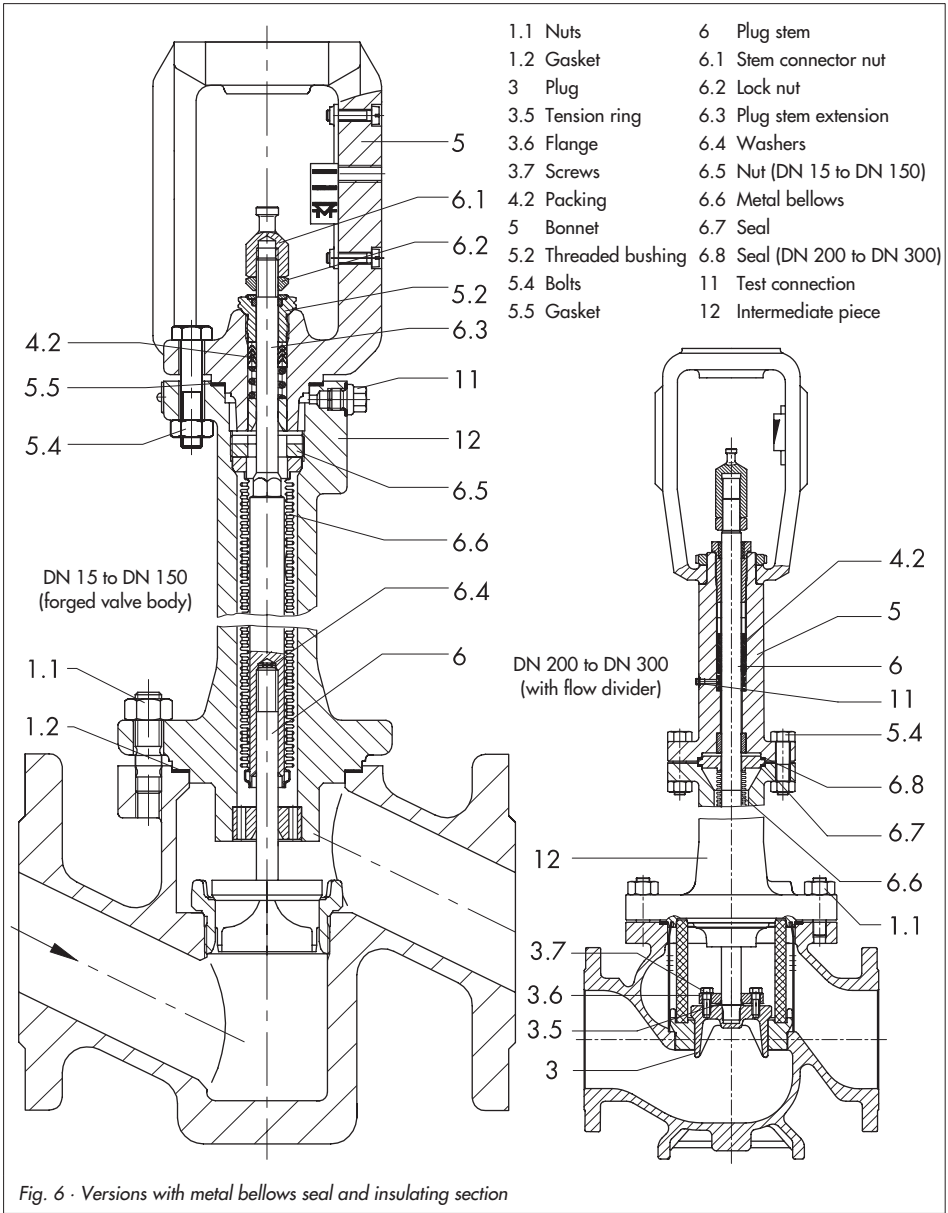

are still in the plug stem extension (6.3). Screw the plug stem firmly into the plug stem extension (6.3); tightening torque is 50 Nm for  $\varnothing$  10 mm and 80 Nm for  $\varnothing$  16 mm.

- ▶ To complete assembly, refer to section 5.2.5.

### Nominal sizes DN 200 to DN 300:

1. Remove the nuts (1.1).
  2. Remove the intermediate piece (12) together with the plug stem and plug from the valve body.
  3. Remove gasket (1.2) and carefully clean the sealing faces in the valve body and on the intermediate piece.
  4. Remove the hexagon head screws (3.7), tension ring (3.5) and flange (3.6).
  5. Unscrew the plug from the plug stem. To do so, use a suitable tool to hold the plug stem in place, so that the metal bellows, which is welded onto the plug stem, cannot be twisted.
  6. Screw a new plug with tension ring and flange to the plug stem.
- ▶ To complete assembly, refer to section 5.2.5.

In the version with insulating section, there are no parts 3.5, 3.6 and 3.7. Plug (3) and plug stem(6) form one piece.

### 5.2.3 Seat

Replace the seat (2) as described in section 5.1.2.

### 5.2.4 Metal bellows

#### Nominal sizes DN 15 to DN 150:

1. Unscrew the plug (3) together with the plug stem (6) from the plug stem extension (6.3) as described for replacing the seat in section 5.2.2.
2. Unscrew the nut (6.5) using a SAMSON socket wrench (see EB 029 EN).
3. Pull the plug stem extension with the welded-on metal bellows (6.6) out of the intermediate section (12).
4. Clean the sealing faces on the intermediate piece.
5. Insert a new plug into the intermediate piece and screw down the nut (6.5).



#### **Caution!**

*Do not twist the metal bellows!*

---

6. Check whether both washers (6.4) are still in the plug stem extension (6.3). Apply lubricant (order no. 8150-0111) to the thread of the plug stem and firmly screw the plug stem into the plug stem extension (6.3) with a tightening torque of 50 Nm for a plug stem diameter of 10 mm and 80 Nm for a diameter of 16 mm.

### Nominal sizes DN 200 to DN 300:

1. Unscrew the plug (3) from the plug stem as described in section 5.2.2.  
Pull the plug stem (6) together with the metal bellows (6.6) upwards, out of the intermediate piece (12).
2. Replace the seal (6.7) and insert a new plug stem with metal bellows (6.6).
3. Screw on the plug and secure with the tension ring (3.5), flange (3.6) and screws (3.7).

### 5.2.5 Reassembly

1. Insert new gasket (1.2) into the valve body. Place the intermediate piece (12) onto the valve body (1) and secure with nuts (1.1).
2. Insert new gasket (5.5) into the intermediate piece. Place the valve bonnet (5) onto the intermediate piece and secure with bolts (5.4) and nuts. Observe the tightening torques specified in EB 029 EN.
3. Tighten the threaded bushing (5.2).
4. Loosely screw the lock nut (6.2) and stem connector nut (6.1) onto the plug stem extension (6.3) or plug stem.
5. Mount the actuator and adjust the upper and lower bench range values as described in section 2.1.

### 5.3 Replacing the collar or seal

For version with pressure-balanced plug:

1. Unscrew the stem connector nut and lock nut (6.1 and 6.2) from the plug stem.
2. Remove the body nuts (1.1) and carefully lift off the valve bonnet (5) with plug stem (6).
3. Screw the threaded bushing (5.2) out of the stuffing box. Pull plug stem and plug (3) out of the bonnet.
4. Remove gasket (1.2) and carefully clean the sealing faces in the valve body and on the bonnet.

### Nominal size DN 40:

5. Pull the packing (4.2), washer (4.3) and spring (4.1) out of the packing chamber using an appropriate tool. Replace damaged parts.
6. Push out the bushing (3.2) and replace the collar (3.1). Clean the packing chamber thoroughly.
7. Apply lubricant (order no. 8150-0111) to the bushing (3.2) and push it in again.
8. Also apply lubricant to the packing parts, plug stem (6) and the contact faces of the collar (3.1).
9. Insert the plug stem and plug into the valve bonnet.

**Completion of reassembly:**

10. Insert new gasket (1.2) into the valve body. Carefully place the valve bonnet on the valve body and secure with nuts (1.1). Observe the tightening torques specified in EB 029 EN.
11. Slide the stuffing box parts over the plug stem into the packing chamber. Make sure to keep the proper order.
12. Screw in the threaded bushing (5.2) and tighten.
13. Loosely screw the lock nut (6.2) and stem connector nut (6.1) onto the plug stem.
14. Mount the actuator and adjust the upper and lower range values as described in section 2.1.

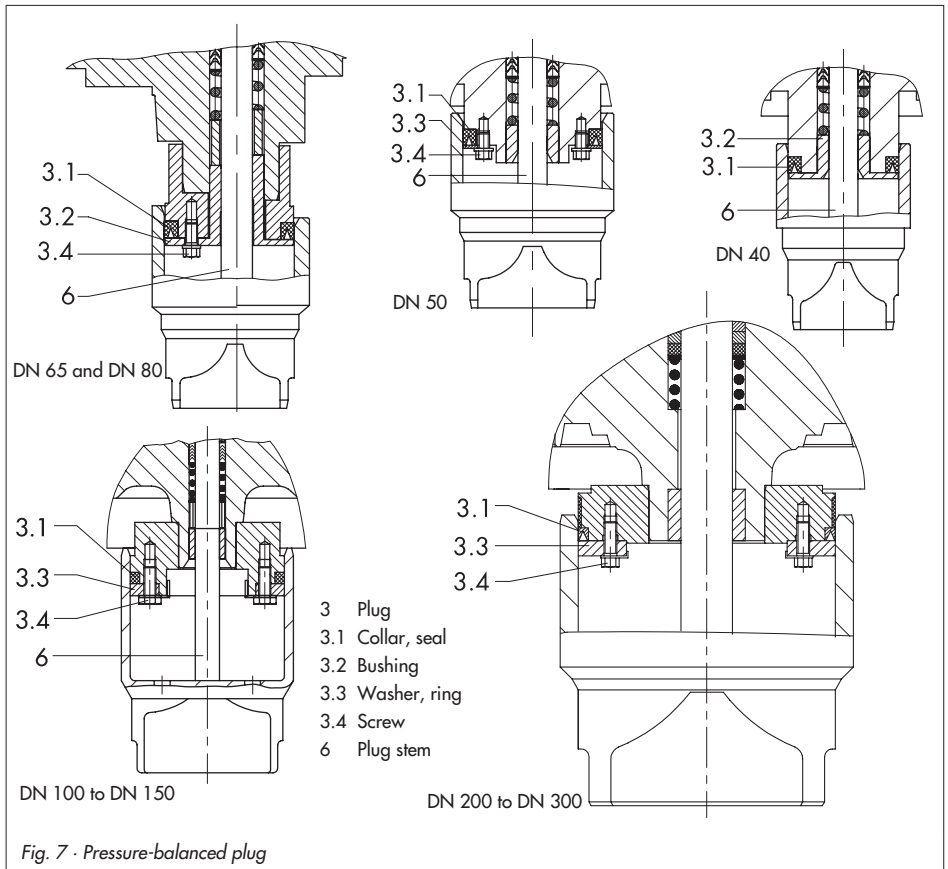

### Nominal sizes DN 50 to DN 150

5. Remove screw (3.4) with its locking device and washer (3.3). Replace collar (3.1).
  6. Insert washer (3.3). Thread down the screw (3.4) with its locking device.
  7. Apply lubricant (order no. 8150-0111) to the packing parts, plug stem (6) and contact faces of the collar (3.1).
  8. Insert the plug stem and plug into the valve bonnet.
- ▶ Complete reassembly as described for DN 40, steps 10 to 14.

### Nominal sizes DN 200 to DN 300:

5. Remove the screw (3.4) with its locking device.
  6. Lift off the ring (3.3) and replace collar or seal (3.1).
  7. Insert ring (3.3). Thread down screw (3.4) and its locking device.
  8. Apply lubricant (order no. 8150-0111) to the packing parts, plug stem (6) and contact faces of the collar (3.1).
  9. Insert the plug stem and plug into the valve bonnet.
- ▶ Complete reassembly as described for DN 40, steps 10 to 14.

## 6 Material identifying marks

Guide bushing, seat and plug have the following identifying marks:

### Guide bushing (groove on plane face)

- ▶ No groove: 1.4305
- ▶ Sharp recessed groove: 1.4571
- ▶ Flat recessed groove: Hastelloy

### Seat

The material number according to DIN is either stamped or engraved on the seat.

- ▶ Stellite seats are marked by a stamped-on "st".

### Plug

Groove below the plug stem thread:

- ▶ No groove: 1.4006
- ▶ Sharp recessed groove: 1.4571
- ▶ Two sharp recessed grooves: 1.4301
- ▶ Flat recessed groove: Hastelloy
- ▶ When other materials are used, either the material number or its designation is engraved on the plug.

The **Kvs coefficient and characteristic** are engraved on the plug.

- ▶ Stellite plugs are marked by an engraved "st".

---

### Dimensions and weights

Refer to the associated Data Sheet for dimensions and weights of the valve versions:

Type 3241 - DIN version      T 8015 EN

Type 3241 - ANSI version      T 8012 EN

Type 3246 - Class 150/300      T 8046-1 EN

---

## 7 Description of nameplates

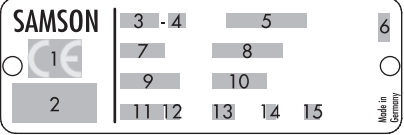

- 1 CE marking or "Art. 3, Abs.3" (see article 3, § 3 of PED), where applicable
- 2 Identification no. of notified body, fluid group and category, where applicable
- 3 Type designation
- 4 Modification index of valve
- 5 Material
- 6 Year of manufacture
- 7 Nominal size: DIN: DN, ANSI: NPS
- 8 Permissible excess pressure at room temperature  
DIN: PN, ANSI: CL
- 9 Order number with modification index
- 10 Position of item in order
- 11 Flow coefficient:  
DIN:  $K_{vs}$ , ANSI:  $C_v$
- 12 Characteristic:  
% equal percentage, Lin linear,  
DIN: **A/Z** quick opening, ANSI: **O/C**
- 13 Sealing:  
**ME** metal, **ST** stellite, **Ni** nickel-plated  
**PT** soft sealing with PTFE,  
**PK** soft sealing with PEEK
- 14 Pressure-balanced: DIN: **D**, ANSI: **B**
- 15 I or III flow divider

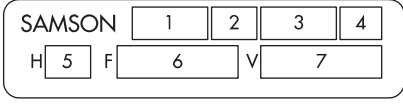

- 1 Type designation
- 2 Modification index
- 3 Effective diaphragm area
- 4 Fail-safe action:  
FA Actuator stem extends  
FE Actuator stem retracts
- 5 Travel
- 6 Bench range (spring range)
- 7 Bench range with pretensioned springs

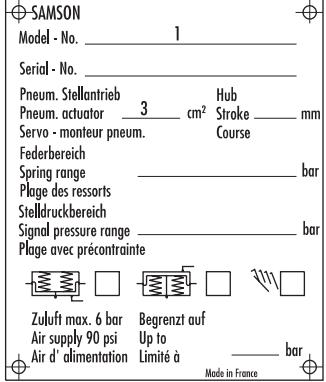

SAMSON  
 Model - No. \_\_\_\_\_ 1 \_\_\_\_\_  
 Serial - No. \_\_\_\_\_  
 Pneum. actuator \_\_\_\_\_ 3 \_\_\_\_\_ cm<sup>2</sup> Hub \_\_\_\_\_ mm  
 Servo - monteur pneum. \_\_\_\_\_ Course \_\_\_\_\_  
 Federbereich \_\_\_\_\_  
 Spring range \_\_\_\_\_ bar  
 Plage des ressorts \_\_\_\_\_  
 Stelldruckbereich \_\_\_\_\_  
 Signal pressure range \_\_\_\_\_ bar  
 Plage avec précontrainte \_\_\_\_\_  
  
 Zuluft max. 6 bar Begrenzt auf \_\_\_\_\_ bar  
 Air supply 90 psi Up to \_\_\_\_\_  
 Air d'alimentation Limité à \_\_\_\_\_ bar  
 Made in France

Fig. 8 - Valve nameplate (left) and actuator nameplates (right)

## 8 Customer inquiries

If you encounter any problems, please submit the following details:

- ▶ Order number
- ▶ Type, product number, nominal size and version of the valve

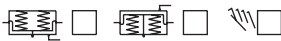
- ▶ Pressure and temperature of the process medium
- ▶ Flow rate in m<sup>3</sup>/h
- ▶ Bench range of the actuator (e.g. 0.2 to 1 bar)
- ▶ Has a strainer been installed?
- ▶ Installation drawing



SAMSON AG · MESS- UND REGELTECHNIK  
Weismüllerstraße 3 · 60314 Frankfurt am Main · Germany  
Phone: +49 69 4009-0 · Fax: +49 69 4009-1507  
Internet: <http://www.samson.de>

**EB 8015 EN**

S/Z 2008-02