

PENBERTHY®

Flat Glass Gages

Series M

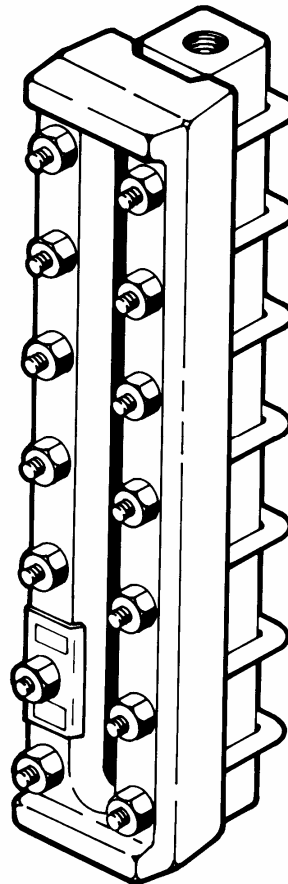

Installation, Operation and Maintenance Instructions

TABLE OF CONTENTS

Product Warranty	iii
1.0 About the Manual	1
2.0 Introduction	1
2.1 System Description	1,2
3.0 Available Models	2
3.1 Design Ratings at Max. & Min. Operating Temperatures	2,3
4.0 Inspection	4
4.1 Glass Inspection	4
4.2 User Rating Inspection	4
5.0 Installation	5
5.1 Piping Strain	5
5.2 Differential Thermal Expansion	5
5.3 Mirror Viewing	5
5.4 Nut Retorquing	5,6
5.5 Belleville Washers	6,7
6.0 Operation	7
6.1 Hydrostatic Test	7
7.0 Maintenance	7,8
7.1 Maintenance Procedures.	8
7.2 Troubleshooting	9
8.0 Removal - Disassembly - Reassembly	9
8.1 Disassembly	9,10
8.2 Inspection of Glass Seating Surfaces	10
8.3 Reassembly	10,11
9.0 Disposal at End of Useful Life	12
10.0 Telephone Assistance	12
11.0 Exploded Parts Drawing	13
TABLES AND FIGURES		page
Table 1	Design Ratings of RM & RMR Gage	2
Table 2	Design Ratings of TM & TMR Gage	3
Table 3	Bolt Torque Values	6
Figure 1	Nut Tightening Sequence	5
Figure 2	Belleville Washer Position	7
Figure 3	Nut Loosening Sequence	9
Figure 4	Exploded Parts Drawing of Transparent Gage	13
Figure 5	Exploded Parts Drawing of Reflex Gage	13

PENBERTHY PRODUCT WARRANTY

Tyco Valves & Controls Prophetstown warrants its Penberthy products as designed and manufactured by TV&C Prophetstown to be free of defects in the material and workmanship for a period of one year after the date of installation or eighteen months after the date of manufacture, whichever is earliest. TV&C Prophetstown will, at its option, replace or repair any products which fail during the warranty period due to defective material or workmanship.

Prior to submitting any claim for warranty service, the owner must submit proof of purchase to TV&C Prophetstown and obtain written authorization to return the product. Thereafter, the product shall be returned to TV&C in Prophetstown, Illinois, with freight paid.

This warranty shall not apply if the product has been disassembled, tampered with, repaired or otherwise altered outside of TV&C Prophetstown factory, or if it has been subject to misuse, neglect or accident.

The responsibility of TV&C Prophetstown hereunder is limited to repairing or replacing the product at its expense. TV&C Prophetstown shall not be liable for loss, damage or expenses related directly or indirectly to the installation or use of its products, or from any other cause or for consequential damages. It is expressly understood that TV&C Prophetstown is not responsible for damage or injury caused to other products, buildings, personnel or property, by reason of the installation or use of its products.

THIS IS TV&C PROPHETSTOWN'S SOLE WARRANTY AND IN LIEU OF ALL OTHER WARRANTIES, EXPRESSED OR IMPLIED WHICH ARE HEREBY EXCLUDED, INCLUDING IN PARTICULAR ALL WARRANTIES OF MERCHANTABILITY OR FITNESS FOR A PARTICULAR PURPOSE.

This document and the warranty contained herein may not be modified and no other warranty, expressed or implied, shall be made by or on behalf of TV&C Prophetstown unless made in writing and signed by the General Manager or Director of Engineering of TV&C Prophetstown.

INSTALLATION, OPERATION and MAINTENANCE MANUAL FOR PENBERTHY SERIES M FLAT GLASS GAGES

1.0 About the Manual

This manual has been prepared as an aid and guide for personnel involved in installation or maintenance. All instructions must be read and understood thoroughly before attempting any installation, operation or maintenance.

SAFETY INSTRUCTIONS

Penberthy does not have any control over the manner in which its liquid level gage is handled, installed or used. Penberthy cannot and will not guarantee that a liquid level gage is suitable or compatible for the user's specific application.



WARNING

Contained fluids may be pressurized and can unexpectedly exit vessel connections due to apparatus or material failure. Safety glasses should be worn when installing a liquid level gage. Failure to follow instructions could result in serious physical injury.

2.0 Introduction

Penberthy liquid level gages are used to allow direct visualization of liquid level in vessels. By peering through the glass, it is possible to monitor color, clarity and level of a gas/liquid interface. Gages are available in varying lengths and configurations (end connect, side connect, multiple sections, NPT or flange connections, etc.). Visual indication can be enhanced by using reflex glass or illuminators (accessory).

2.1 System Description

Penberthy gages are comprised of six basic components. Each component may vary slightly, depending on the desired physical and mechanical properties for the gage. Use the exploded parts view in Section 11.0 as additional reference material.

- Chamber- provides a pressure retaining metallic channel for the liquid to enter and be viewed. Slot(s) are machined into the chamber to provide direct visualization of the process fluid.
- Gaskets- seal the gap and prevent leakage between the chamber and the glass. Gaskets are available in a variety of materials for compatibility with the media in the gage.
- Glass- allows for visual observation of the process fluid in the chamber.
- Cushion- acts as a protective buffer between the glass and the cover. For proper sealing, cushions must be as hard or harder than the gasket material.
- Cover- protects the glass assembly from external hits and provides a flat, rigid surface that is used to evenly compress the gage assembly.

Bolting- compresses the components between the covers (transparent gages) or cover and chamber (reflex gages).

Shield - (optional on transparent gages) used to prevent the process media from contacting the glass.

3.0 Available Models

Penberthy medium pressure (Series M) liquid level gages are designed for applications other than steam/water: 1) requiring pressure ratings lower than that of Penberthy Series H liquid level gages, 2) where pressure ratings are greater than those possible using low pressure (Series L) liquid level gages, or 3) for Series L pressure ranges where iron covers are not allowed.

3.1 Design Ratings at Maximum and Minimum Operating Temperatures

Gasket Material	Glass Size	Model RM & RMR Reflex	
		Wetted Parts Material Steel or Stainless Steel w/B7 Bolting	
		-20°F (-29°C) to 100°F (38°C)	600°F (316°C)
Grafoil® (standard) or Non-Asbestos	1	3000 psig (20680 kPa)	2220 psig (15310 kPa)
	2	2910 psig (20060 kPa)	2150 psig (14820 kPa)
	3	2820 psig (19440 kPa)	2080 psig (14340 kPa)
	4	2725 psig (18790 kPa)	2040 psig (14070 kPa)
	5	2630 psig (18130 kPa)	1950 psig (13440 kPa)
	6	2535 psig (17480 kPa)	1875 psig (12930 kPa)
	7	2440 psig (16820 kPa)	1805 psig (12450 kPa)
	8	2345 psig (16170 kPa)	1740 psig (12000 kPa)
	9	2250 psig (15510 kPa)	1660 psig (11450 kPa)
Top-Chem 2000®	1	3000 psig (20680 kPa)	100 psig (690 kPa) at 500°F (260°C)
	2	2910 psig (20060 kPa)	
	3	2820 psig (19440 kPa)	
	4	2725 psig (18790 kPa)	
	5	2630 psig (18130 kPa)	
	6	2535 psig (17480 kPa)	
	7	2440 psig (16820 kPa)	
	8	2345 psig (16170 kPa)	
	9	2250 psig (15510 kPa)	
25% glass filled PTFE	1 - 9	650 psig (4480 kPa) at -20°F (-29°C) to 100°F(38°C) 150 psig (1030 kPa) at 500°F (260°C)	
NBR/Buna N	1 - 9	300 psig (2070 kPa) at -20°F (-29°C) to 100°F(38°C) 225 psig (1550 kPa) at 250°F (121°C)	
FKM/Viton®	1 - 9	300 psig (2070 kPa) at -20°F (-29°C) to 100°F(38°C) 180 psig (1240 kPa) at 400°F (204°C)	
PTFE/Teflon®	1 - 9	300 psig (2070 kPa) at -20°F (-29°C) to 100°F(38°C) 150 psig (1030 kPa) at 500°F (260°C)	

Table 1

NOTE: Lower temperatures are possible with metallic material variation. (e.g., 316 Stainless construction, Grafoil® gaskets/cushions useable to -325°F [-198°C]).

Gasket Material	Glass Size	Model TM & TMR Transparent	
		Wetted Parts Material Steel or Stainless Steel w/B7 Bolting	
Grafoil® (standard) or Non-Asbestos		-20°F (-29°C) to 100°F (38°C)	600°F (316°C)
	1	2500 psig (17240 kPa)	1850 psig (12760 kPa)
	2	2315 psig (15960 kPa)	1720 psig (11860 kPa)
	3	2130 psig (14690 kPa)	1575 psig (10860 kPa)
	4	1940 psig (13380 kPa)	1435 psig (9890 kPa)
	5	1750 psig (12070 kPa)	1295 psig (8930 kPa)
	6	1565 psig (10790 kPa)	1160 psig (8000 kPa)
	7	1375 psig (9480 kPa)	1015 psig (7000 kPa)
	8	1190 psig (8200 kPa)	880 psig (6070 kPa)
	9	1000 psig (6890 kPa)	740 psig (5100 kPa)
Top-Chem 2000®	1	2500 psig (17240 kPa)	100 psig (690 kPa) at 500°F (260°C)
	2	2315 psig (15960 kPa)	
	3	2130 psig (14690 kPa)	
	4	1940 psig (13380 kPa)	
	5	1750 psig (12070 kPa)	
	6	1565 psig (10790 kPa)	
	7	1375 psig (9480 kPa)	
	8	1190 psig (8200 kPa)	
	9	1000 psig (6890 kPa)	
25% glass filled PTFE	1 - 9	650 psig (4480 kPa) at -20°F (-29°C) to 100°F(38°C) 150 psig (1030 kPa) at 500°F (260°C)	
NBR/Buna N	1 - 9	300 psig (2070 kPa) at -20°F (-29°C) to 100°F(38°C) 225 psig (1550 kPa) at 250°F (121°C)	
FKM/Viton®	1 - 9	300 psig (2070 kPa) at -20°F (-29°C) to 100°F(38°C) 180 psig (1240 kPa) at 400°F (204°C)	
PTFE/Teflon®	1 - 9	300 psig (2070 kPa) at -20°F (-29°C) to 100°F(38°C) 150 psig (1030 kPa) at 500°F (260°C)	
PCTFE/(Kel-F®) Shields 0.063" (1.6mm) thick	1 - 9	300 psig (2070 kPa) at -20°F (-29°C) to 100°F(38°C) 180 psig (1240 kPa) at 400°F (204°C)	

Table 2

NOTE: Lower temperatures are possible with metallic material variation. (e.g., 316 Stainless construction, Grafoil® gaskets/cushions useable to -325°F [-198°C]).

The pressure and temperature ratings may deviate from the previous tables if the gasketing materials of construction and/or bolting are other than those specified. Higher and/or lower temperature ratings are available with different materials of construction.

To determine the maximum allowable working pressure for a specific temperature within the design limits stated in the tables, the user should refer to Penberthy application sheets, or when provided, the specifically stated design limits on a Penberthy product proposal.

NOTE: under no circumstances should shields be used in reflex style gages. Installation of shields in reflex style gages will keep the liquid from coming in contact with the refractive prisms, thereby prohibiting visualization of the liquid level in the gage.



NEVER exceed these design ratings or application data. Exceeding design ratings or application data may result in mechanical failure of gage components resulting in death, serious personal injury and property damage.

4.0 Inspection

Upon receipt of a liquid level gage, check all components carefully for damage incurred in shipping. If damage is evident or suspected, do not attempt installation. Notify carrier immediately and request damage inspection.

Penberthy's standard 1 section TM & TMR gage consists of: (1) chamber, (2) gaskets, (2) borosilicate flat glass, (2) rubber bands, (2) cushions, (2) covers, (1) washer, (1) nameplate and (6-14) bolting sets, depending on the size.

4.1 Glass Inspection

The self stick caution tape was applied at the factory to protect the glass during shipping, handling and installation. Do not remove the tape from the glass until all installation procedures have been completed, except during receiving inspection to momentarily inspect glass for shipping damage. Glass that is not protected will be vulnerable to dust, grit, tools and any other objects which may scratch, chip or break the glass.



DO NOT use glass that is chipped or even slightly scratched. Glass surface defects weaken the glass, which may result in glass breakage and fluid loss under pressure resulting in serious personal injury and property damage.

4.2 User Rating Inspection

The user should confirm that:

1. the Series M liquid level gage model and assembly number stamped on the nameplate conforms to the description on the user's purchase order,
2. the operating conditions described in the purchase order agree with the actual operating conditions at the installation site,
3. the actual operating conditions at the installation site are within the application data shown on the Penberthy Technical Data Bulletin or product proposal referred to above, and
4. the materials of construction of the liquid level gage are compatible with both the contained media and surrounding atmosphere in the specific application.



If the size, model or performance data of the liquid level gage as received does not conform with any of the criteria above, do not proceed with installation. Contact an authorized Penberthy distributor for assistance. The incorrect gage can result in unacceptable performance and potential damage to the gage.

5.0 Installation

Installation should only be undertaken by qualified, experienced personnel who are familiar with equipment of this type. They should have read and understood all of the instructions in this manual. The user should refer to Penberthy dimension sheets or Penberthy product proposal to obtain dimensional information for the specific size and model liquid level gage.

Penberthy recommends that all liquid level gage installations be provided with gagecock sets equipped with ball check shut-off. Gagecock sets are designed to isolate the gages from the pressure vessel when it becomes necessary to drain or service the gages. The ball check shut-off is designed to retard leakage of the contained fluid in the event of gage glass breakage. Ball checks are available for both positive and negative vessel pressures.

The number of different types of gage and gagecock installations is too great to adequately detail in an installation manual. It is, therefore, the user's responsibility to assure that the knowledgeable installation personnel plan and carry out the installation in a safe manner. The following procedures are some of the installation guidelines that should be employed.

5.1 Piping Strain

The gage should be mounted and connected so that it does not support any piping weight. Piping not properly supported, independent of the gage, may subject the gage to stresses that can cause leaks or glass breakage. Support brackets are available as an accessory.

5.2 Differential Thermal Expansion

High mechanical loads may be imposed on a gage by expanding and contracting pipes due to hot or cold service. Such mechanical loads on the gage must be minimized by the use of expansion loops in the system. Failure to allow for expansion or contraction can result in leaks or glass breakage.

5.3 Mirror Viewing

For added safety, a system of indirect viewing by means of mirrors should be installed to protect personnel from the hazards of possible gage failure.

5.4 Nut Retorquing

Nut retorquing is vital to the operation of a liquid level gage because gaskets take permanent set under initial bolt loading at assembly. Tightening of nuts before installation to values specified in Table 3 is necessary to insure pressure retaining capabilities of liquid level gage to specific design ratings. The user must refer to the liquid level gage model and assembly number and to the purchase order or tag to determine materials of construction.

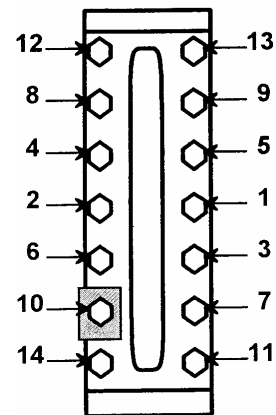

Nut Tightening Sequence
Figure 1

SAFETY INSTRUCTIONS

Before placing liquid level gage into initial operation, torque values must be verified. From factory testing to installation, gasketing may take “set” reducing closure force. Retorquing before operation reduces chance of leakage or gasket “blow out”.

BOLT TORQUE VALUES

GAGE MODELS & GASKET MATERIAL	ft-lb [N·m]
RM, RMR, TM, TMR w/Grafoil® (standard)	25 to 30 [34 to 41]
RM, RMR, TM, TMR w/Non-asbestos (optional)	30 to 35 [41 to 48]
Top-Chem 2000®	25 to 30 [34 to 41]
PTFE and PCTFE (Kel-F®)	20 to 25 [27 to 34]
25% glass filled PTFE	19 to 22 [26 to 30]
All models with Viton® or elastomeric (optional)	10 to 15 [14 to 20]
TM, TMR with PCTFE (Kel-F®) Shields (optional) 0.063" [1.6mm]	20 to 25 [27 to 34]

Table 3

Using a torque wrench, tighten nuts in 5 ft-lb (7 N·m) increments following the "Z" pattern sequence in Figure 1, until the torque values shown in Table 3 above for the specific liquid level gage are reached. For multiple section gages, torque the center section(s) and progressively work toward the ends of the gage.

If bolting, gasketing or glass on any repaired section of a multi-section gage is disturbed, all sections must be checked for integrity and retorqued as necessary.



WARNING

Failure to comply with the proper torquing sequence or force value can lead to leakage, gasket blow-out or glass breakage resulting in gage failure, serious personal injury or property damage.

NOTE: Depending on gage size there may be less bolting than shown in Figure 1. Start at the center and follow "Z" pattern outward to the limit of bolting on a specific gage.

5.5 Belleville Washers

Belleville washers are used to reduce the need to retorque nuts. This is especially important for gages subject to pressure and/or thermal cycling. The conical washers allow for material expansion and contraction while maintaining axial bolt loading and, therefore, compression on the gasket.

Model RM & RMR gages require 4 washers per nut, model TM & TMR gages require 2 washers per nut (4 per bolt). Washers should be assembled with cupped side facing the gage cover. Refer to Figure 2 for proper washer assembly.

Note: the following procedure is to be done on only one side of a transparent gage.

Using a torque wrench, tighten nuts in 5 ft-lb (7 N·m) increments following the “Z” pattern sequence found in Figure 1 until the torque values shown in Table 3 are reached.

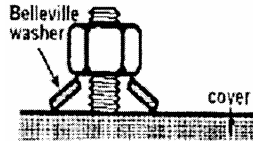

**Belleville Washer Position
Figure 2**

6.0 Operation

Before initializing liquid level gage operation, check that all installation procedures have been completed. Use only qualified experienced personnel who are familiar with liquid level gage equipment and thoroughly understand the implications of the tables and all the instructions. Check to determine that all connections are pressure tight. Assure that nuts have been retorqued to their proper values as specified in Table 3. Remove self stick caution tape from the glass and inspect to be sure that glass is clean and free of any damage such as cracks, scratches, pits and chips.

6.1 Hydrostatic Test



Liquid level gage installations should be brought into service slowly to avoid excessive shock or stress on the glass. Rapid pressurization or sudden changes in temperature may cause glass breakage. To avoid excessive thermal shock or mechanical stress on glass, the connecting gagecocks should be opened slightly, and the gage temperature and pressure allowed to slowly equalize. If the gagecocks are equipped with ball checks, the gagecocks must be opened all the way after the pressure and temperature have equalized to permit operation of the automatic ball checks in the event of failure. Failure to follow the recommended operating procedures can result in death, severe personal injury and/or property damage.

Take all precautions necessary to handle the possibility of leakage during the test. Hydrostatically pressure test all installations to at least 100 psig (690 kPa) but less than the design pressure and correct any leakage before proceeding.

7.0 Maintenance



Use only qualified experienced personnel who are familiar with liquid level gage equipment and thoroughly understand the implications of the tables and all the instructions. DO NOT proceed with any maintenance unless the liquid level gage has been relieved of all pressure or vacuum, has been allowed to reach ambient temperature and has been drained or purged of all fluids. Failure to follow instructions can cause serious personal injury and property damage.

The rate at which components degrade is dependent upon a variety of conditions. Pressure, temperature and process media all influence the rate at which gage components deteriorate. Higher temperatures can accelerate the deterioration of gaskets, cushions, glass and metals. Acids and similar chemicals can break down the integrity of almost any material. Concentration of chemicals can accelerate the corrosion rate. Penberthy cannot create a blanket maintenance schedule for every application.

The end user is the most familiar with the process media and conditions and must be responsible for creating a maintenance schedule. The user must create maintenance schedules, safety manuals and inspection details for each liquid level gage. Realistic maintenance schedules can only be determined with full knowledge of the services and application situations involved. These will be based upon the user's own operating experience with their specific application.

If bolting, gasketing or glass on any section of a multi-section gage is disturbed, all sections must be checked for integrity and retorqued or repaired as necessary.

On all installations the following items should be regularly evaluated by the user for purposes of maintenance:

1. glass, for cleanliness and signs of damage or wear,
2. shields, if used, for signs of clouding, wear or deterioration,
3. gage, for signs of leakage around gaskets or at connections and
4. gage, for signs of internal or external corrosion.

7.1 Maintenance Procedures

GLASS should be given regular and careful attention. Keep glass clean using a commercial glass cleaner and a soft cloth. Inspect the surface of the glass for any clouding, etching or scratching or physical damage such as bruises, checks or corrosion. Glass that is damaged is weakened and may break under pressure. Shining a light at approximately a 45° angle will aid in detecting some of these conditions. Typical damaged areas will glisten more brightly than the surrounding glass because the light is reflected.

Detection of any damage, problem areas or surface wear is sufficient evidence to take the liquid level gage out of service. DO NOT proceed with operation of the liquid level gage until the glass has been replaced with a glass replacement kit following the disassembly-reassembly instructions in Section 8.0.

SHIELDS showing any signs of clouding, wear or deterioration are an indication that the gage glass has been exposed, or could soon be exposed to the contained fluid. Immediately take liquid level gage out of service. DO NOT proceed with operation of the liquid level gage until shields and glass have been replaced by following the disassembly-reassembly instructions in Section 8.0.

GASKET LEAKS must be repaired immediately. DO NOT proceed with operation of a liquid level gage until gaskets have been replaced by following Section 8.0 disassembly-reassembly instructions.

CONNECTION LEAKS at a flanged or threaded connection should be corrected by tightening the bolting at the connection or by taking the liquid level gage out of service and wrapping the connection threads with Teflon[®] tape on all male pipe threads.

CORROSION may occur if the user has selected an improper material for the liquid level gage application. It is the responsibility of the user to choose a material of construction compatible with both the contained fluid and the surrounding environment. If internal or external corrosion is present, an investigation must immediately be performed by the user. It may be necessary to contact an authorized Penberthy distributor to better determine the origin of the corrosion.

7.2 Troubleshooting

Problem: glass becomes prematurely etched or clouded in service

Cause: fluid being handled is not compatible with the glass or shields

Solution: replace the glass and install shields which will not be affected by contained fluid

Problem: glass continually breaks in service despite careful attention to maintenance procedures

Cause: thermal shock, hydraulic shock, mechanical loads, exceeding design ratings or a combination of these

Solution: check entire system to determine possible sources of loads. Check application to determine actual operating conditions and contact an authorized Penberthy distributor on how to proceed.

8.0 Removal - Disassembly - Reassembly



Use only qualified experienced personnel who are familiar with liquid level gage equipment and thoroughly understand the implications of the tables and all the instructions. **DO NOT** proceed with any maintenance unless the liquid level gage has been relieved of all pressure or vacuum, has been allowed to reach ambient temperature and has been drained or purged of all fluids. Failure to follow instructions can cause serious personal injury and property damage.

8.1 Disassembly

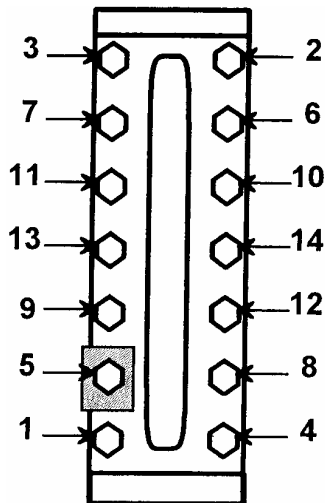

Nut Loosening Sequence
Figure 3

Secure workbench longer than the liquid level gage, and sufficiently wide to lay out parts as they are removed.

1. Lay gage on bench so nut side of fastener is up.
2. Hold gage firmly; loosen nuts starting at both ends of each section and then proceeding from both ends to the center of each section as shown in Figure 3.
3. Nut Loosening Sequence
 - remove nuts, washer, belleville washers (if any) and nameplate
 - tap covers with rubber hammer as needed to loosen and remove
 - for belleville washer assemblies: to remove covers, studs may need to be removed by laying the assembly on its side and knocking the stud/U-bolts through the cover with a hammer and punch
 - remove cushions, glass, shields (if any) and gaskets
 - tap liquid chamber or remaining covers as necessary with rubber hammer to break loose and remove remaining components
 - remove, destroy and dispose of all glass, cushions, gaskets and shields. Under no circumstances should these components be re-used or installed on a gage.

NOTE: If size of gage is smaller than shown, follow spiraling sequence from the ends until all bolting is loosened.



WARNING

Once used, cushions, gaskets and shields are permanently deformed by compression and if re-used, may cause leaks and high stress points resulting in glass breakage. Glass may contain hidden damage and internal stresses caused by previous usage. If re-used, the glass may break under pressure causing severe personal injury or property damage.

8.2 Inspection of Glass Seating Surfaces

Clean the glass seating surfaces on the liquid chamber and cover with a soft metal scraper (preferably brass) to remove all burrs, rust and remnants of the previous gaskets and cushions. Exercise extreme care to avoid gouging or scarring gasket and cushion seating surfaces.

Use a known flat piece of metal the same approximate length as the glass or a new piece of glass and a thickness gage to check flatness of each glass seating surface on liquid chamber and under cover. Surface must be flat within 0.002 inch (0.05 mm). If any one surface is found to be beyond a tolerance of 0.002 inch (0.05 mm), the entire gage must be disposed of and replaced. Gasket seating surface must have a final surface finish of 450 to 500 AARH.



WARNING

Flatness of glass seating surfaces outside 0.002 inch (0.05 mm) tolerance specified is an indication of the gage having been overstressed through repeated exposure to mechanical, thermal or hydraulic shock during its previous service. Operation of a liquid level gage which has been overstressed will result in abnormal stresses on the glass which may cause glass to break. If surface finish is not in the 450-500 AARH range, gasket may extrude under pressure with resulting sudden release of pressure, leakage of contained fluid, serious personal injury or property damage.

Glass seating surfaces should NOT be machined to achieve seating tolerance. The chamber and cover are designed for a critical thickness to achieve the pressure/temperature ratings. Machining glass seating surfaces may result in non-compliance to the necessary critical thickness due to material removal.

8.3 Reassembly

If all glass seating surfaces are found to be within the 0.002 inch (0.05 mm) tolerance described in the previous section, proceed to obtain new glass, gaskets, cushions and shields (if used) and proceed to reassemble as follows (refer to exploded parts view in Section 11.0 if needed):

1. Clean threads on bolt and nuts to remove all paint, rust and scale. Apply a light coat of oil to the threads.
2. For transparent gages, insert bolts through half the cover and lay out covers along the bench, side by side, with the liquid chamber. Use chamber to space covers and line them up with vision slots.
3. For reflex style and belleville reflex style gages, lay out covers along bench, side by side, with liquid chamber. Use chamber to space covers and line them up with vision slots.

4. For transparent belleville style gages, thread nuts on stud, place two belleville washers under nut with pointed end toward the nut (see Figure 2), insert stud through each cover and lay out covers along bench, side by side, with liquid chamber. Use chamber to space covers and line them up with vision slots.
5. Install one cushion inside each cover.



Separate installation instructions are supplied with replacement glass. All instructions supplied with the glass must be followed, as there are precautions to be taken when handling gage glass. Among the precautions is avoidance of bumping or sliding glass against any surface and inspection of individual pieces. Failure to follow any of the replacement gage glass installation instructions could result in glass breakage with resulting sudden release of pressure, severe personal injury or property damage.

6. Install rubber band around each piece of glass, then place glass centered inside each cover.
7. Install shields, if used, and gasket on glass being careful to keep components centered.
8. Place liquid chamber on the gaskets making sure all components are aligned with vision slot.
9. For reflex gage, install U-bolts in place by tapping as needed with rubber hammer, being careful not to lose alignment with vision slot.
10. For reflex gage, quickly turn over assembly onto backside of U-bolts. Assemble nameplate, washer and nuts to U-bolts. Tighten nuts with fingers. Using a torque wrench, tighten nuts in 5 ft-lb (7 N-m) increments, following the sequence in Figure 1 until the torque values shown in Table 3 are reached.

NOTE: Depending on gage size there may be less bolting than shown in Figure 1. Start at the center and follow "Z" pattern outward to the limit of bolting on a specific gage.

11. For transparent gage, install gaskets and shields, if used, centered on vision slots.
12. Install rubber band around each piece of glass, then place glass centered on gasket or shields, if used.
13. Install one cushion on each piece of glass.
14. Install covers in place being careful to maintain components alignment inside.
15. Install nameplate, washer and nuts to bolts. Tighten nuts with fingers. Using a torque wrench, tighten nuts in 5 ft-lb (7 N-m) increments, following the sequence in Figure 1 until the torque values shown in Table 3 are reached.
- 15A. For transparent belleville style gages: install nameplate and two belleville washers under each nut with pointed end toward the nut (see Figure 2). Finger tighten nuts.

NOTE: the following procedure is to be done on only one side of the gage.

- 15B. For reflex belleville style gages: install nameplate and four belleville washers under each nut with pointed end toward the nut (see Figure 2). Finger tighten nuts.
16. Using a torque wrench, tighten nuts in 5 ft-lb (7 N-m) increments, following the sequence in Figure 1, until the torque values shown in Table 3 are reached.

Refer to Section 5.0 for installation and Section 6.0 for operation of liquid level gage when returning to service.

9.0 Disposal at End of Useful Life

Penberthy gages are used in a variety of fluid applications. By following the appropriate federal and industry regulations, the user must determine the extent of preparation and treatment the gage must incur before its disposal. A Material Safety Data Sheet (MSDS) may be required before disposal services accept certain components.

Metal, glass and polymers should be recycled whenever possible. Refer to order and TV&C - Prophetstown Material Specification sheets for materials of construction.

10.0 Telephone Assistance

If you are having difficulty with your liquid level gage, contact your local Penberthy distributor. You may also contact the factory direct at (815) 537-2311 and ask for an applications engineer. So that we may assist you more effectively, please have as much of the following information available as possible when you call:

- Model #
- Name of the company from whom you purchased the liquid level gage
- Invoice # and date
- Process conditions (pressure, flow rates, tank shape, etc)
- A brief description of the problem
- Trouble shooting procedures that failed

If attempts to solve your problem fail, you may request to return your liquid level gage to the factory for intensive testing. You must obtain a Return Authorization (R.A.) number from TV&C Prophetstown before returning anything. Failure to do so will result in the unit being returned to you without being tested, freight collect. To obtain an R.A. number, the following information (in addition to that above) is needed:

- Reason for return
- Person to contact at your company
- "Ship To" address

There is a minimum charge for evaluation of non-warranty units. You will be contacted before any repairs are initiated should the cost exceed the minimum charge. If you return a unit under warranty, but is not defective, the minimum charge will apply.

Grafoil[®] is a registered trademark of Graftech
Top Chem 2000[®] is a registered trademark of Klinger
PCTFE (Formerly known as Kel-F[®], a registered trademark of 3M) is manufactured by Daikin
Viton[®] and Teflon[®] are registered trademarks of E.I. du Pont de Nemours and Company

11.0 Exploded Parts Drawing

Recommended Spare Parts		
REF #	ITEM	QTY.
100	Bolt/U-bolt	2/1 per sect.
4	Nut	2 per sect.
48	Glass	1
7	Gasket	2
8	Cushion	2
9	Shield (if used)	2

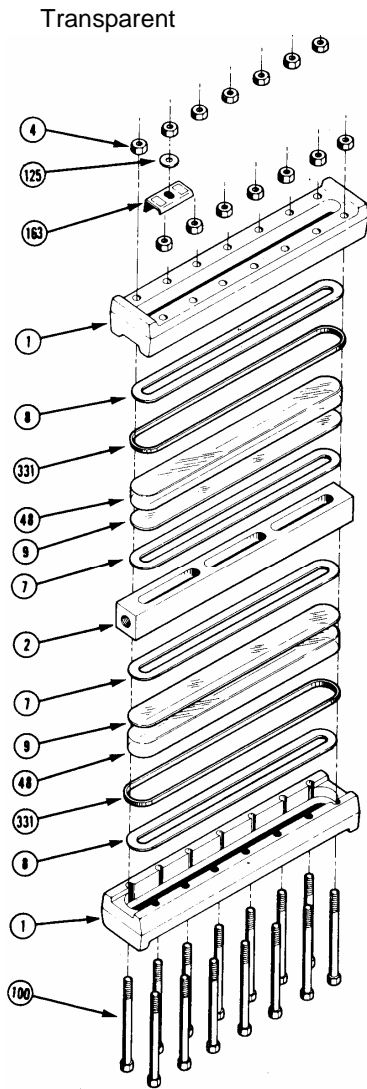

Figure 4

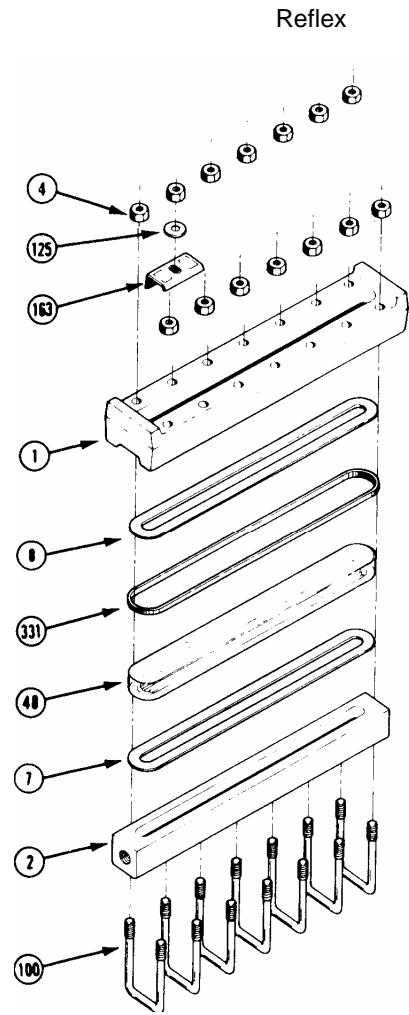

Figure 5

- 1 Cover
- 2 Chamber
- 4 Nut
- 48 Glass
- 7 Gasket
- 8 Cushion
- 9 Shield
- 100 Bolt/U-Bolt
- 125 Washer
- 163 Nameplate Band
- 331 Band

NOTE: size 9 shown - actual gage may be shorter and require fewer bolting components.

PENBERTHY

DECLARATION of CONFORMITY

In conformance with ISO/IEC Guide 22 - 96
LLG.DC r C

Manufacturer's Name: Tyco Valves & Controls
Manufacturer's Address: 320 Locust Street
Prophetstown, IL 61277-1147 U.S.A.

Product:
Type of Equipment: Pressure Vessel - Liquid Level Gage Glass
Equipment Class: Industrial Instrumentation - Hazardous Area
Model Designations: RL, TL, RM, RMR, TM, TMR, RH, RHR, TH, THR, RMW, TMW, RLC, TLC

The product described above is in conformity with:

92/59/EEC	General product safety	1992
87/404/EEC	Simple pressure vessel	1987
89/392/EEC	Machinery	1989
EN 10213-1:4	Technical delivery conditions for steel castings	1996
ISO 7-1	Pipe threads where pressure-tight joints are made	1996
BS 10 1962	Flanges and bolting for pipes, gagecocks and fittings	
BS 21	Pipe threads for tubes and fittings where pressure tight	1985
BS 759 1984	Gagecocks, gages and other safety fittings for application	
BS 970 Part 1	Wrought steels for mechanical and allied engineering	1996
BS 970 Part 3	Wrought steel for mechanical and allied engineering	1991
BS 1501 Part 3	Steels for pressure purposes	1990
BS 1502	Steels for fired and unfired pressure vessels	1982
BS 1506	Carbon, low alloy and stainless steel bars and billets	1990
BS 1560	Circular flanges for pipes, gagecocks and fittings	1989
BS 1640 Part 1	Steel butt-welding pipe fittings	1962
BS 1640 Part 2	Steel butt-welding pipe fittings	1962
BS 1965	Butt-welding pipe fittings	1963
BS 3076	Nickel and nickel alloys: bar	1989
BS 3463	Observation and gage glasses for pressure vessels	1975
BS 3602 Part 1	Steel pipes and tubes for pressure purposes	1987
BS 3605	Austenitic stainless steel pipes and tubes	1991
BS 3643	ISO metric screw threads	1981
BS 3799	Steel pipe fittings, screwed and socket-welding	1974
BS 4504	Circular flanges for pipes, gagecocks and fittings	1989
ASME B&PV Code Section VIII	Rules for construction of pressure vessels	1995
ANSI/ASME B1.1	Unified screw inch threads un and unr thread form	1982
ANSI/ASME B1.20.1	Pipe threads, general purpose (inch)	1983
ANSI/ASME B16.5	Pipe flanges and flanged fittings	1988
ANSI/ASME B18.2.1	Square and hex nuts and screw inch series	1981
ANSI/ASME B18.2.2	Square and hex nuts	1972
ANSI/ASME B31.3	Process piping	1996

Date: 03 June 2004

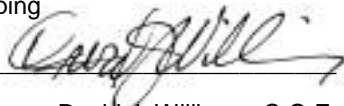
Signature: 

Prophetstown, IL U.S.A.

Name: David J. Williams, C.Q.E.
Position: Quality Assurance Manager

Technical Construction File is available at stated address. Signatory is contact person.

NOTES

NOTES

tyco / *Flow Control* / **Tyco Valves
& Controls**

Penberthy

Tyco Valves & Controls, L.P. Prophetstown
320 Locust St., Prophetstown, Illinois 61277
Phone: 815-537-2311
FAX: 815-537-5764
Printed in USA
Part No. 18R66-009

© 2005 Tyco Valves & Controls, L.P. Prophetstown, All Rights Reserved