

Series 3 Liquid Level Switches

Installation and Operating Manual



*Liquid
Level
Switches
ASME
B31.3
Construction*

Read this Manual Before Installing

This manual provides information on Series 3 Liquid Level Switches. It is important that all instructions are read carefully and followed in sequence. Detailed instructions are included in the Installation section of this manual.

Conventions Used in this Manual

Certain conventions are used in this manual to convey specific types of information. General technical material, support data, and safety information are presented in narrative form. The following styles are used for notes, cautions, and warnings.

NOTES

Notes contain information that augments or clarifies an operating step. Notes do not normally contain actions. They follow the procedural steps to which they refer.

Cautions

Cautions alert the technician to special conditions that could injure personnel, damage equipment, or reduce a component's mechanical integrity. Cautions are also used to alert the technician to unsafe practices or the need for special protective equipment or specific materials. In this manual, a caution box indicates a potentially hazardous situation which, if not avoided, may result in minor or moderate injury.

WARNINGS

Warnings identify potentially dangerous situations or serious hazards. In this manual, a warning indicates an imminently hazardous situation which, if not avoided, could result in serious injury or death.

Safety Messages

Follow all standard industry procedures for servicing electrical equipment when working with or around high voltage. Always shut off the power supply before touching any components.

Low Voltage Directive

For use in Installation Category II, Pollution Degree 2. If equipment is used in a manner not specified by the manufacturer, protection provided by the equipment may be impaired.

Notice of Trademark, Copyright, and Limitations

Magnetrol & Magnetrol logotype and STI & STI logotype are registered trademarks of Magnetrol International.

Copyright © 2009 Magnetrol International, Incorporated. All rights reserved.

Performance specifications are effective with date of issue and are subject to change without notice. Magnetrol reserves the right to make changes to the product described in this manual at any time without notice. Magnetrol makes no warranty with respect to the accuracy of the information in this manual.

Warranty

All Magnetrol/STI mechanical level and flow controls are warranted free of defects in materials or workmanship for five full years from the date of original factory shipment. Repair parts are warranted free of defects in materials and workmanship for one year from the date of shipment. Materials, specifications, and contents are subject to change without prior written notice.

If returned within the warranty period; and, upon factory inspection of the control, the cause of the claim is determined to be covered under the warranty; then, Magnetrol/STI will repair or replace the control at no cost to the purchaser (or owner) other than transportation.

Magnetrol/STI shall not be liable for misapplication, labor claims, direct or consequential damage or expense arising from the installation or use of equipment. There are no other warranties expressed or implied, except special written warranties covering some Magnetrol/STI products.

Quality Assurance

The quality assurance system in place at Magnetrol/STI guarantees the highest level of quality throughout the company. Magnetrol/STI is committed to providing full customer satisfaction both in quality products and quality service.

Magnetrol's quality assurance system is registered to ISO 9001 affirming its commitment to known international quality standards providing the strongest assurance of product/service quality available.





Series 3 Liquid Level Switches ASME B31.3 Construction

Table of Contents

1.0 Introduction	
1.1 Principle of Operation	4
1.2 Operating Cycle	4
2.0 Installation	
2.1 Unpacking	4
2.2 Critical Alarm Function	5
2.3 Piping	5
2.4 Mounting	5
2.5 Wiring	6
3.0 Switch Differential Adjustment	
3.1 Low Level Controls	8
3.2 High Level Controls	9
4.0 Preventive Maintenance	
4.1 What To Do	10
4.1.1 Keep Control Clean	10
4.1.2 Inspect Switch Mechanisms, Terminals, and Connections Monthly	10
4.1.3 Inspect Entire Unit Periodically	11
4.1.4 Control Head Removal and Installation	12
4.1.5 Functional Test of Unit	13
4.2 Troubleshooting	14
4.2.1 Check Switch Mechanism	14
4.2.2 Check Sensing Unit	15
4.3 What To Avoid	16
5.0 Reference Information	
5.1 Agency Approvals	17
5.2 Specifications	18
5.2.1 Dimensional Specifications — Sealed Cage Models	18
5.2.2 Dimensional Specifications — Flanged Cage Models	20
5.2.3 Actuating Levels, Steam Service Ratings and Specific Gravities	23
5.3 Replacement Parts	25
5.3.1 Sealed Cage Float Models B35, C35, G35, K35, L35, V35 and Z35 Parts Identification	25
5.3.2 Sealed Cage Float Models B35, C35, G35, K35, L35, V35 and Z35 Part Numbers	25
5.3.3 Sealed Cage Displacer Model B34 Parts Identification	26
5.3.4 Sealed Cage Displacer Model B34 Part Numbers	26
5.3.5 Flanged Cage Displacer Model C34 Parts Identification	27
5.3.6 Flanged Cage Displacer Model C34 Part Numbers	27
5.3.7 Flanged Cage Float Models B3F, G3F, K3F and Z3F w/Material Code 1 Parts Identification	28
5.3.8 Flanged Cage Float Models B3F, G3F, K3F and Z3F w/Material Code 1 Part Numbers	28
5.3.9 Flanged Cage Float Models B3F, G3F, K3F and Z3F w/Material Code 2 & N Parts Identification	29
5.3.10 Flanged Cage Float Models B3F, G3F, K3F and Z3F w/Material Code 2 & N Part Numbers	29
5.4 Model Numbers	
5.4.1 Sealed Cage Models	30
5.4.2 Flanged Cage Models	32

1.0 Introduction

Magnetrol's Series 3 level switches are float operated units suitable for use on clean liquid applications for level alarm, pump control and safety shutdown functions. Units are designed, fabricated and certified to compliance with ASME B31.3 specifications.

1.1 Principle of Operation

The design of Magnetrol float operated level switches is based upon the principle that a magnetic field will penetrate non-magnetic materials such as 316 stainless steel. In this case, the float moves a magnetic attraction sleeve within a non-magnetic enclosing tube and actuates a switch mechanism. The enclosing tube provides a pressure seal to the chamber and therefore to the process.

1.2 Operating Cycle

As the liquid level rises in the chamber (refer to **Figure 1**), the float moves the magnetic attraction sleeve up within the enclosing tube and into the field of the switch mechanism magnet. As a result, the magnet is drawn in tightly to the enclosing tube causing the switch to trip, “making” or “breaking” an electrical circuit. As the liquid level falls, the float drops and moves the attraction sleeve out of the magnetic field, releasing the switch at a predetermined “low level” (refer to **Figure 2**). The tension spring ensures the return of the switch in a snap action.

2.0 Installation

2.1 Unpacking

Unpack the instrument carefully. Inspect all units for damage. Report any concealed damage to carrier within 24 hours. Check the contents of the packing slip and purchase order. Check and record the serial numbers and model numbers for future reference when ordering parts.

Serial # _____

Model # _____

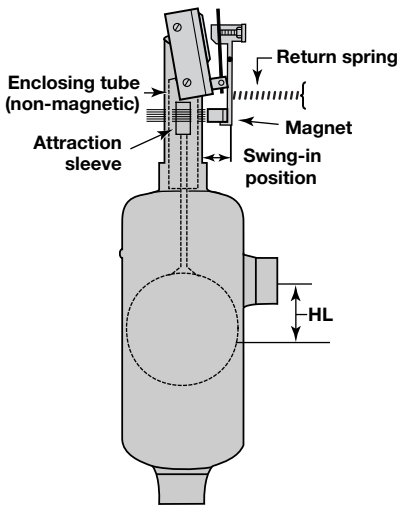

Figure 1
Switch Tripped

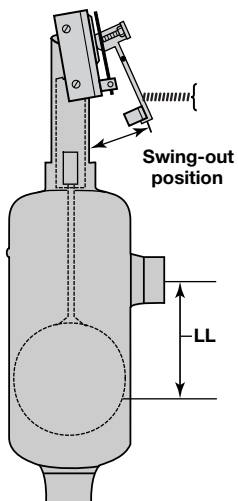

Figure 2
Switch Released

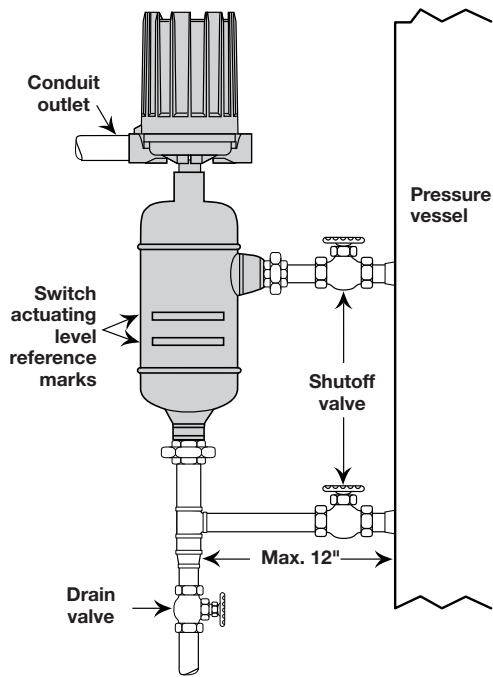

Figure 3
Typical Piping Arrangement

2.2 Critical Alarm Function

It is recommended that for critical alarm functions, an additional level switch be installed as a high-high or low-low level alarm for maximum protection.

2.3 Piping

Figure 3 shows a typical piping installation of a Magnetrol Series 3 control to a pressure vessel. Level decals on control identify the actuation levels for the bottom switch mechanism of a unit with three switches at minimum specific gravity. Charts defining actuation levels for a unit with one switch at different specific gravities can be found on pages 23–24, *Actuating Levels and Specific Gravities*, Section 5.2.3.

Use pipe of sufficient strength to support the control. If necessary, provide a stand or hanger to help support its weight. All piping should be straight and free of “low spots” or “pockets” so that lower liquid line will drain towards the vessel and upper vapor line will drain toward the control. Shut-off valves are recommended for installation between the vessel and the control. If control is to be used with a low temperature liquid (one which will “boil” in the float chamber if outside heat is absorbed), the chamber and piping should be insulated. Such boiling in the chamber will cause false level indications.
DO NOT INSULATE SWITCH MECHANISM HOUSING.

On controls equipped with pneumatic switch assemblies, consult bulletin on mechanism furnished for air (or gas) piping instructions. Refer to the **Switch Instruction Reference Bulletins** chart on page 7 to find bulletin numbers for pneumatic switches.

2.4 Mounting

Caution: If equipment is used in a manner not specified by the manufacturer, protection provided by the equipment may be impaired.

Caution: This instrument is intended for use in Installation Category II, Pollution Degree 2.

Adjust piping as required to bring control to a vertical position. Magnetrol controls must be mounted within 3° of vertical. A 3° slant is noticeable by eye, but installation should be checked with a spirit level on top and/or sides of float chamber.

Controls should be mounted as close to the vessel as possible. This will result in a more responsive and accurate level change in the control. Liquid in a long line may be cooler and more dense than liquid in the vessel causing lower level indication in the control than actual level in the vessel.

2.5 Wiring

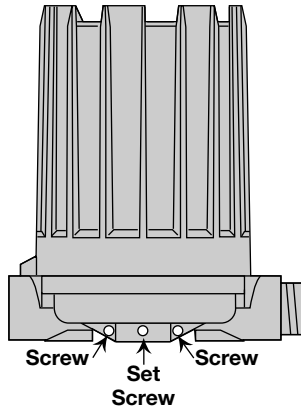

Figure 4
NEMA 4X/7/9

NOTE: A switch or circuit breaker shall be installed in close proximity to equipment and within easy reach of operator. It shall be marked as the disconnecting device for the equipment.

NOTE: For supply connections in installations with ambient temperature up to +158° F (+70° C), use wire with a minimum rating of +167° F (+75° C) as required by the process conditions. Installations with ambient temperatures up to +176° F (+80° C) require wire with a minimum rating of +185° F (+85° C) as required by the process conditions. Use a minimum of 14 AWG wire for power and ground field wires.

Caution: Level controls are shipped from the factory with the enclosing tube tightened and the middle set screw, on the housing base, locked to the enclosing tube. Failure to loosen the set screw prior to repositioning the conduit connection may cause the enclosing tube to loosen, resulting in the possible leakage of the process liquid or vapor.

Series 3 controls are shipped with the conduit entry of the switch housing placed 180° opposite to the tank configurations to simplify installation in most cases. If this configuration is appropriate to the installation, proceed to step 4 to begin wiring the unit. If another configuration is desired, the switch housing can be easily rotated by first following steps 1, 2, and 3.

1. Loosen set screw(s) at base of switch housing. Refer to **Figure 4**.
2. Switch housing may be rotated 360° to allow correct positioning of conduit outlet.
3. Tighten set screw(s) at base of switch housing.
4. Unscrew and remove switch housing cover. The threads have been lubricated to facilitate removal.

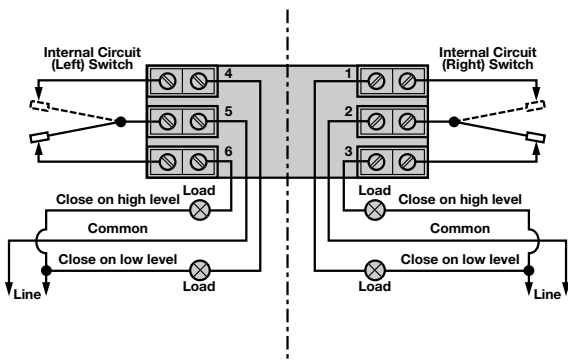

Figure 5
Wiring diagram for DPDT
Series B, C, D, F, R, 8 & 9 switches

NOTE: On high temperature applications (above +250° F [+121° C] in float chamber), high temperature wire should be used between control and first junction box located in a cooler area. On non-hazardous applications, flexible conduit may be used between the control and the first junction box.

5. The switch terminals are located next to the conduit outlet to facilitate wiring. Bring supply wires through conduit outlet. Route extra wire around enclosing tube under the

baffle plate, and connect them to the proper terminals. Refer to the wiring diagram in your switch bulletin for this information. See **Switch Instruction Reference Bulletins** chart below for switch instruction bulletin numbers.

Switch Instruction Reference Bulletins

Switch Series Letter	Description	Bulletin No.
B, C, D	Dry Contact Switch	42-683
F	High Temperature Hermetically Sealed Snap Switch	42-683
HS, H1	Hermetically Sealed Snap Switch	42-694
R, 8, 9	High Temperature Snap Switch	42-799
J	Bleed Type Pneumatic Switch	42-685
K	Non-Bleed Type Pneumatic Switch	42-686

NOTE: For models with a Series HS switch with high temperature lead wire, the leads are routed out through the conduit opening by the factory. A suitable conduit box should be provided for the connection of the leads to the control wiring.

6. Dress wiring to ensure no interference or contact with the switch housing cover.

OBSERVE ALL APPLICABLE ELECTRICAL CODES AND PROPER WIRING PROCEDURES.

Prevent moisture seepage into the enclosure by installing approved seal-drain fittings in the conduit run leading into the unit.

Caution: In hazardous areas, do not power the unit until the conduit is sealed and the enclosure cover is screwed down securely.

7. Replace housing cover.
8. If control has been furnished with an explosion proof or moisture proof (gasketed) switch housing, it must be sealed at the conduit outlet with a suitable compound or non-hardening sealant to prevent entrance of air.
9. Test switch action by varying liquid level in float chamber.

NOTE: If switch mechanism fails to function properly, check vertical alignment of control housing and consult installation bulletin on switch mechanism furnished.

10. Check cover to base fit to be certain gasketed joint is tight. A positive seal is necessary to prevent infiltration of moisture laden air or corrosive gases into switch housings.

3.0 Switch Differential Adjustment

The standard differential of Series 3 float models with one switch mechanism may be field-adjusted. Adjustment may be necessary if a wider differential needs to be set to overcome switch chatter caused by the process.

The differential, or the amount of level travel between “switch-on” and “switch-off,” may be adjusted by repositioning the lower jam nuts on the float stem. This adjustment is different for high level and low level controls. Refer to the appropriate section below for adjustment instructions.

Caution: Maximum differential adjustment is 1 inch (25 mm). Differential adjustment may be done only on models with a single switch mechanism.

3.1 Low Level Controls

On low level controls the switch trips on the lower actuation point and resets on the higher actuation point. Widening the differential will allow the switch to trip on the original actuation point and reset at a later, or higher, point.

The differential on low level controls may be adjusted by repositioning the lower jam nuts on the float stem. The standard factory setting is for a minimum amount of play (gap) between the top jam nuts and the attraction sleeve as shown in **Figure 7** on page 9.

1. Determine what change in differential is necessary.

NOTE: To widen the differential one inch, the lower jam nuts must be set proportionately lower on the stem (i.e., in this example 1 inch).

2. Make sure power source is turned off.
3. NEMA 4X/7/9—Unscrew and remove switch housing cover.
4. Disconnect power supply wires from switch mechanism. Pull wires out of conduit connection opening in housing base. Refer to **Figure 6**.
- 5a. Perform system shut-down procedures as required to relieve pressure from float chamber of control. Allow unit to cool.
- 5b. Close shut-off valves (if so equipped) to isolate control from tank. Drain off liquid in float chamber. Refer to **Figure 3** on page 5.
- 5c. On installations without shut-off valves, relieve pressure from the tank. Drain liquid in tank to a level below the connections of the float chamber.

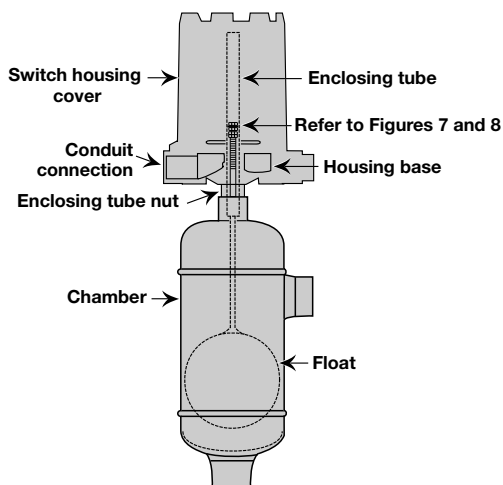
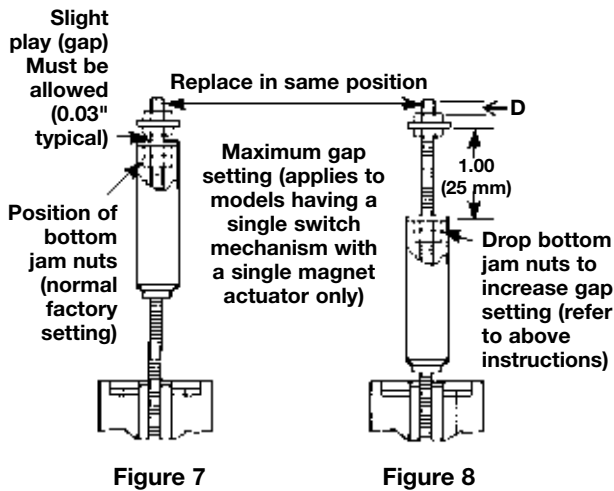

Figure 6



NOTE: Level control, connections and pipe lines need not be removed from the tank.

6. Loosen enclosing tube nut with a $\frac{1}{16}$ " wrench. Unscrew enclosing tube counterclockwise (switch and housing base will rotate also) until it is free. Refer to **Figure 6** on page 8.
7. Lift enclosing tube, switch, and base off float chamber. Jam nuts and attraction sleeve are now accessible.
8. Measure the distance "D" from the top edge of the upper jam nuts to the top of the float stem. Refer to **Figure 8**. Record this measurement.
9. Loosen and remove upper jam nuts, guide washer, and attraction sleeve.
10. Loosen and adjust lower jam nuts to the desired position. Tighten lower jam nuts securely. Refer to **Figure 8**.
11. Replace attraction sleeve on stem.
12. Replace upper jam nuts and guide washer on the stem in the position previously noted. Tighten upper jam nuts securely. Refer to **Figure 8**.

NOTE: Use a new enclosing tube gasket when reassembling enclosing tube to the chamber. Make certain that all gasket surfaces are thoroughly cleaned to allow proper gasket seating. Coat enclosing tube threads with "anti-seizing" compound.

13. Replace enclosing tube, switch, and base on chamber. Screw tube clockwise until tightened to 200–225 foot-pounds of torque.
14. Rotate switch housing to correct position and tighten set screw at base of switch housing. Refer to **Figure 4** on page 6.
15. Bring supply wires through conduit outlet. Follow steps 5 through 10 in *Wiring, Section 2.5* on pages 6 and 7.
16. Test switch action by varying liquid level in float chamber.

NOTE: If switch mechanism fails to function properly, check vertical alignment of control housing and consult installation bulletin on switch mechanism. If the unit still fails to function properly, consult the factory.

3.2 High Level Controls

On high level controls the switch trips on the higher actuation point and resets on the lower actuation point.

Caution: On high level controls, widening the differential requires raising the trip point a proportional amount. The reset point will remain the same.

To widen the differential by raising the trip point, follow steps 1 through 16 in *Low Level Controls, Section 3.1*, pages 8–9).

Caution: After increasing gap setting, be certain to check for proper operation of switch mechanism by raising and lowering float assembly. Magnet must "snap" cleanly with additional float movement available after magnet snaps.

4.0 Preventive Maintenance

Periodic inspections are a necessary means to keep your level control in good working order. This control is a safety device to protect the valuable equipment it serves. A systematic program of "preventive maintenance" must be implemented when the control is placed into service. If the following sections on "what to do" and "what to avoid" are observed, your control will provide reliable protection of your equipment for many years.

4.1 What To Do

4.1.1 Keep Control Clean

Be sure the switch housing cover is always in place on the control. This cover is designed to keep dust and dirt from interfering with switch mechanism operation. In addition, it protects against damaging moisture and acts as a safety feature by keeping bare wires and terminals from being exposed. Should the housing cover or any seals become damaged or misplaced, obtain a replacement immediately.

4.1.2 Inspect Switch Mechanisms, Terminals, and Connections Monthly

1. Dry contact switches should be inspected for excessive wear on actuating lever or misalignment of adjustment screw at point of contact between screw and lever. Such wear can cause false switch actuating levels. See switch mechanism bulletin supplied with control should switch adjustment or replacement be necessary.
2. DO NOT operate your control with defective or mal-adjusted switch mechanisms. Refer to the **Switch Instruction Reference Bulletins** chart on page 7 to find appropriate bulletins for service instructions.
3. Level controls may sometimes be exposed to excessive heat or moisture. Under such conditions, insulation on electrical wiring may become brittle, eventually breaking or peeling away. The resulting "bare" wires can cause short circuits.

NOTE: Check wiring carefully and replace at the first sign of brittle insulation.

4. Vibration may sometimes cause terminal screws to loosen. Check all terminal connections to be certain that screws are tight.
5. On units with pneumatic switches, air (or gas) lines subjected to vibration, may eventually crack or loosen at connections causing leakage. Check lines and connections carefully and repair or replace, if necessary.

NOTE: Spare switches should be kept on hand at all times.

4.1.3 Inspect Entire Unit Periodically

Isolate control from vessel. Raise and lower liquid level to check for switch contact and reset.

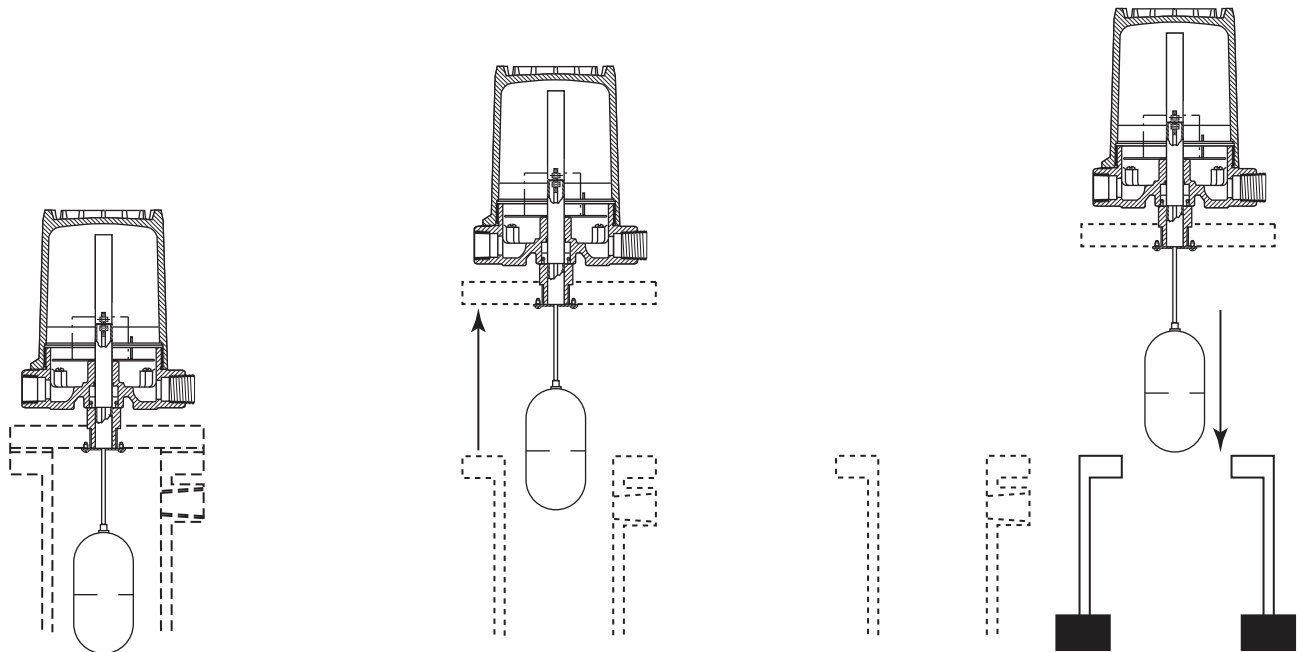

Figure 9

4.1.4 Control Head Removal and Installation

Inspection of the interior of the chamber is possible on flanged cage models. To do this, the control head must be removed to provide proper access to the chamber. This procedure will assure that the head assembly is removed and reinstalled properly.

1. Allow vessel to get to safe temperature and pressure before opening the pressure boundary.
2. Power down all wiring to the unit.
3. Remove all wiring and conduit from the unit.
4. Remove flange bolts.
5. Prepare an area where the head assembly can be placed such that it rests on the flange in its normal orientation (two 2×4 boards placed across an open drum work well). Refer to **Figure 9** on page 11.
6. Carefully lift the head assembly by holding the sides of the flange. Maintain the head assembly as much as possible in the vertical position.

NOTE: Care must be taken not to place side force on the float which could bend the stem.

7. With the unit resting in its temporary fixture in an upright position, it can now be inspected or repaired.

Caution: Do not place the unit on its side — this could result in damage to the stem.

8. Conduct a check for float stem straightness as follows:
 - 8.1 Remove the stem assembly including attraction sleeve from the head assembly by removing the two screws holding the stop strap to the bottom of the flange. See **Figure 10** for assembly schematic.
 - 8.2 Check the stem straightness by aligning the stem against a straight edge. Stems that are bent in excess of $\frac{1}{8}$ inch over any 6 inch length should not be used in this condition. Replace any bent stems. See *Replacement Parts, Section 5.3* beginning on page 25.
 - 8.3 Ensure that the components in the stem assembly are in good condition and surfaces are clear of potential obstructions. The stem assembly is reinstalled by securing the stop strap to the flange. Ensure that the attraction sleeve moves freely through the enclosing tube and that the stem assembly surfaces are smooth.

NOTE: Care must be taken during the straightness check to be certain that the attraction sleeve is not removed from the stem and jam nuts settings are not changed.

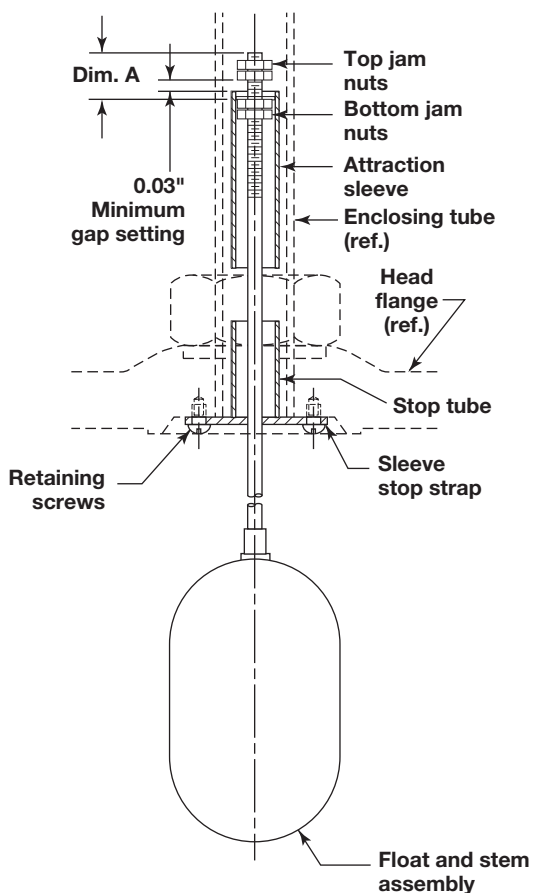

Figure 10

9. In the container that the unit is set on, raise the liquid level sufficiently to lift the float and trip the switch mechanism. Inspect inside of chamber for any obstructions or scale buildup. If excessive buildup is present, the interval between inspections should be shortened. Remove old gasket such that mating flange surfaces are completely clean. Position new gasket on chamber flange before replacing the head assembly.

NOTE: The float is restricted from moving laterally by the chamber, in the test configuration the float and stem can move further off center than possible under normal operation. Avoid excess movement in this lateral direction during the test. If switch trips, the unit may be reassembled.

10. Replace the assembly onto the float cage keeping it as vertical as possible. Carefully lower the assembly into the chamber making sure that the stem does not become bent during installation. Refer to **Figure 9** on page 11.
11. Tighten flange bolts per torque values as indicated in table below.

Model	Flange Bolting	Enclosing Tube
B3F – 150#	100 – 120 ft-lbs	200–225 ft-lbs
B3F – 300#, G3F – 150#, G3F – 300#	180 – 200 ft-lbs	
B3F – 600#	300 – 320 ft-lbs	
G3F – 600#, Z3F – 600#	470 – 490 ft-lbs	
K3F – 600#	675 – 710 ft-lbs	
Z3F – 900#	775 – 850 ft-lbs	

12. Attach wiring and connect power supply as described in *Wiring, Section 2.5* on page 6.

4.1.5 Functional Test of Unit

This procedure will assure that the complete unit is functioning properly. This test should be conducted after switch and wiring inspections have been completed.

1. Adjust piping as required to bring control to a vertical position. Control must be mounted within 3° of vertical. Installation should be checked with an indicating level on top or sides of float chamber.
2. Check that the chamber is mounted within 3° of vertical after vessel installation is complete.
3. Raise level in the vessel sufficient to raise the float and trip the switch. Lower level in the vessel sufficient to lower float and reset the switch. Confirm switch trips and resets at expected levels (contact Magnetrol for specific information on trip points; have the serial number of the unit readily available).

4.2 Troubleshooting

Usually the first indication of improper operation is failure of the controlled equipment to function, i.e., pump will not start (or stop), signal lamps fail to light, etc. When these symptoms occur, whether at time of installation or during routine service thereafter, check the following potential external causes first:

- Fuses may be blown
- Reset button(s) may need resetting
- Power switch may be open
- Controlled equipment may be faulty
- Wiring leading to control may be defective

If a thorough inspection of these possible conditions fails to locate the trouble, proceed next to a check of the control's switch mechanism.

4.2.1 Check Switch Mechanism

1. Pull switch or otherwise disconnect power to the control.
2. Remove switch housing cover.
3. Disconnect power wiring from switch assembly.
4. Swing magnet assembly in and out by hand to check carefully for any sign of binding. Assembly should require minimal force to move it through its full swing.
5. If binding exists, magnet may be rubbing enclosing tube. If magnet is rubbing, loosen magnet clamp screw and shift magnet position. Retighten magnet clamp screw.
6. If switch magnet assembly swings freely and mechanism still fails to actuate, check installation of control to be certain it is within the specified 3° of vertical.
7. Examine the switch closely as described in *Inspect Switch Mechanisms, Terminals, and Connections Monthly*, Section 4.1.2, step 1 on page 10. Check continuity of switch with ohmmeter. If switch does not function properly, replace it immediately.
8. If switch mechanism is operating satisfactorily, proceed to check sensing unit.

NOTE: Spare switches should be kept on hand at all times.

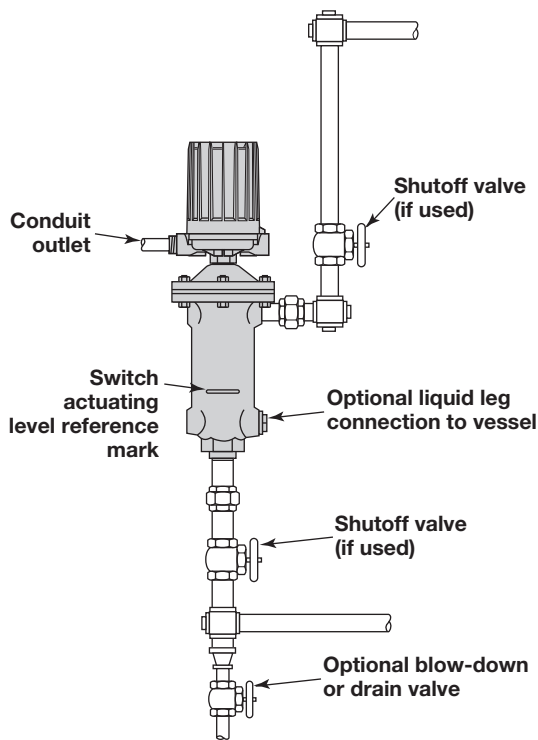

Figure 11

4.2.2 Check Sensing Unit

1. Reconnect power supply. Carefully actuate the switch mechanism manually (use a non-conductive tool on electrical switch mechanisms) to determine whether controlled equipment will operate.

Caution: With electrical power on, avoid contact with switch leads and connections at terminal block.

2. If controlled equipment responds to manual switch actuation test, trouble may be located in the level sensing portion of the control, float(s), stem(s), and magnetic attraction sleeve(s).
3. Check to be certain liquid is entering float chamber. A valve may be closed or piping plugged.

Caution: Be certain to pull disconnect switch or otherwise ensure that electrical circuit(s) through control is deactivated. Close operating medium supply valve on controls equipped with pneumatic switch mechanisms.

4. Disconnect wiring from supply side of switch mechanism(s) and remove electrical conduit or operating medium line connections to switch housing.
5. Perform system shutdown to relieve pressure from float chamber of control and allow unit to cool.
6. Close shutoff valves (if equipped) to isolate control from vessel. Drain off liquid in chamber if necessary
7. On installations without shutoff valves, relieve pressure from vessel and drain off liquid head above control mounting level.

NOTE: Control chamber, connections, and pipe lines need not be removed from vessel or boiler.

8. Remove switch housing assembly by loosening enclosing tube hex nut, which is located immediately below housing base. Refer to **Figure 6** on page 8.
9. With switch housing assembly removed, inspect attraction sleeve(s) and inside of enclosing tube for excessive corrosion or solids buildup, which could restrict movement, preventing sleeve(s) from reaching field of switch magnet(s).
10. If differential has been changed in the field by repositioning the lower jam nuts on the float stem, check tightness and position of the jam nuts.
11. Check float to be certain it is buoyant in the liquid (float chamber or vessel must have adequate liquid level). If float is determined to be filled with liquid, or it is collapsed, it must be replaced immediately.

Caution: Do not attempt to repair a float. See *Replacement Parts, Section 5.3* beginning on page 25.

If all components in the control are in operating condition, the trouble is likely located external to the control. Repeat inspection of external conditions previously described.

NOTE: If difficulties are encountered which cannot be identified, consult the factory or your local representative for assistance. A complete description of the trouble should be provided along with information concerning your piping and mounting arrangement, plus a description of your operating sequence. Sketches or photographs showing the installation are also beneficial.

When communicating about your control, be certain to always specify the complete Model and Serial numbers.





4.3 What To Avoid

1. Never leave switch housing cover off the control longer than necessary to make routine inspections.
2. Never place a jumper wire across terminals to “cut-out” the control. If a “jumper” is necessary for test purposes, be certain it is removed before placing control into service.
3. Never attempt to make adjustments or replace switches without reading instructions carefully. Certain adjustments provided for in level controls should not be attempted in the field. When in doubt, consult the factory or your local representative.
4. Never use lubricants on pivots of switch mechanisms. A sufficient amount of lubricant has been applied at the factory to ensure a lifetime of service. Further oiling is unnecessary and will only tend to attract dust and dirt which can interfere with mechanism operation.

Caution: Operation of all buoyancy type level devices should be done in such a way as to minimize the action of dynamic forces on the float or displacer sensing element. Good practice for reducing the likelihood of damage to the control is to equalize pressure across the device very slowly.

5.0 Reference Information

5.1 Agency Approvals

AGENCY	APPROVED MODEL	APPROVAL CLASSES
FM 	All with an electric switch mechanism and a housing listed as Type 4X/7/9	Class I, Div 1, Groups C & D Class II, Div 1, Groups E, F & G
	All with an electric switch mechanism and a housing listed as Type 4X/7/9 Class I, Div 1, Group B	Class I, Div 1, Groups B, C & D Class II, Div 1, Groups E, F & G
CSA 	All with a Series HS, H1, F, 8 & 9 electric switch mechanism and a housing listed as CSA Type 4X	Class I, Div 2, Groups B, C & D
	All with an electric switch mechanism and a housing listed as Type 4X/7/9	Class I, Div 1, Groups C & D Class II, Div 1, Groups E, F & G
	All with an electric switch mechanism and a housing listed as Type 4X/7/9 Class I, Div 1, Group B	Class I, Div 1, Groups B, C & D Class II, Div 1, Groups E, F & G
ATEX / IEC Ex ② 	All with an electric switch mechanism and an ATEX housing ①	ATEX II 2 G EEx d IIC T6 94/9/EC IEC Ex Ex d IIC T6
CE 	Low Voltage Directives 2006/95/EC Per Harmonized Standard: EN 61010-1/1993 & Amendment No. 1	Installation Category II Pollution Degree 2

① Controls with two “HS” or “H1” switches are not ATEX approved.

② IEC Installation Instructions:

The cable entry and closing devices shall be Ex d certified suitable for the conditions of use and correctly installed.

For ambient temperatures above +55° C or for process temperatures above +150° C, suitable heat resistant cables shall be used.

Heat extensions (between process connection and housing) shall never be insulated.

Special conditions for safe use:

When the equipment is installed in process temperatures higher than +85° C the temperature classification must be reduced according to the following table as per IEC60079-0.

Maximum Process Temperature	Temperature Classification
< 85° C	T6
< 100° C	T5
< 135° C	T4
< 200° C	T3
< 300° C	T2
< 450° C	T1

These units are in conformity with IECEx KEM 05.0020X

Classification Ex d IIC T6

T_{ambient} -40° C to +70° C

5.2 Specifications

5.2.1 Dimensional Specifications — Sealed Cage Models

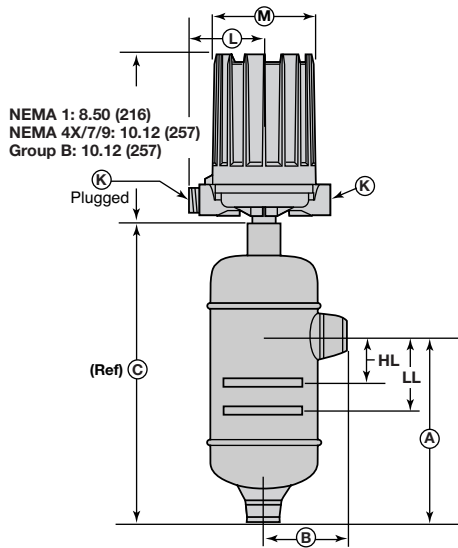

Figure 12
Threaded & Socket Weld
Upper Side/Bottom

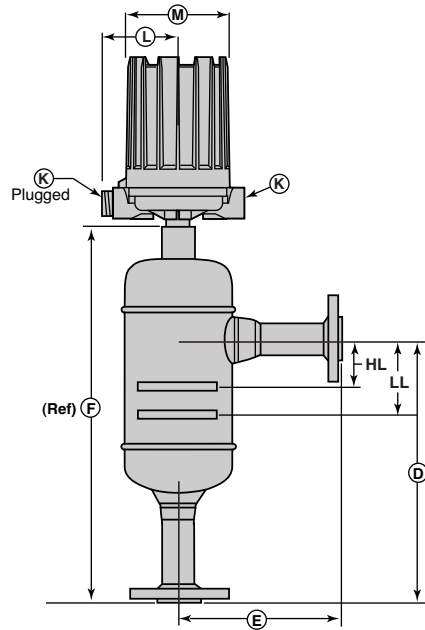

Figure 13
Flanged Upper Side/Bottom

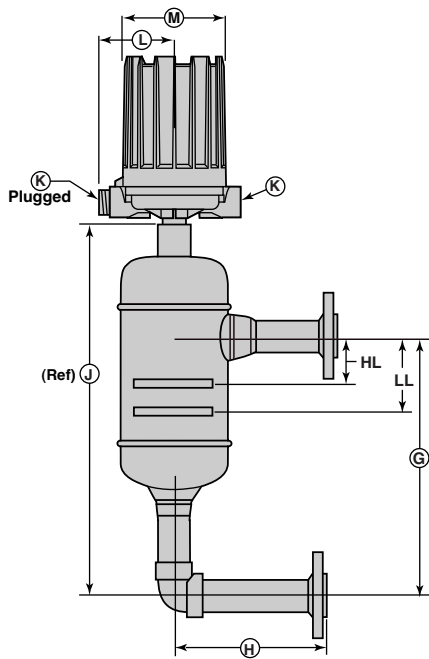

Figure 14
Flanged Side/Side

Conduit Connections K

Electrical Switches	
NEMA 4X/7/9:	1" NPT
Group B:	1" NPT
Pneumatic Switches	
NEMA 1:	¼" NPT

Actuation levels

Outline Dimensions	L	M
NEMA 4X/7/9	3.87	5.93
NEMA 4X/7/9, Group B	(98)	(151)
NEMA 1	5.00	4.62
	(127)	(117)

Allow 8" (203 mm) over head clearance for cover removal.

All housings rotatable 360°.

5.2 Specifications

5.2.1 Dimensional Specifications – Sealed Cage Models (cont.)

Inches (mm)

CHAMBERS WITH 1-INCH CONNECTIONS — 150 LB. AND 300 LB. ANSI CLASS

Model Code	1" NPT Threaded & Socket Weld			1" Flanged Upper Side/Bottom					1" Flanged Side/Side					
	A	B	C	D		E	F		G		H	J		
				Std.	14"		Std.	14"	Std.	14"		Std.	14"	
B34	8.76 (223)	3.63 (92)	13.84 (352)	12.87 (327)	—	6.38 (162)	17.95 (459)	—	13.62 (346)	—	6.38 (162)	18.70 (478)	—	
B35	8.92 (227)	4.15 (105)	15.12 (384)	11.56 (294)	14.00 (356)	6.69 (170)	17.76 (451)	20.20 (513)	12.21 (310)	14.00 (356)	6.69 (170)	18.41 (468)	20.20 (513)	
C35	8.92 (227)	4.15 (105)	15.12 (384)	11.56 (294)	14.00 (356)	6.69 (170)	17.76 (451)	20.20 (513)	12.21 (310)	14.00 (356)	6.69 (170)	18.41 (468)	20.20 (513)	
G35	9.80 (249)	4.69 (119)	16.17 (410)	12.31 (313)	14.00 (356)	7.19 (183)	18.68 (474)	20.36 (517)	12.96 (329)	14.00 (356)	7.19 (183)	19.33 (490)	20.36 (517)	
L35	9.80 (249)	4.69 (119)	16.17 (410)	12.31 (313)	14.00 (356)	7.19 (183)	18.68 (474)	20.36 (517)	12.96 (329)	14.00 (356)	7.19 (183)	19.33 (490)	20.36 (517)	
V35	8.92 (227)	4.15 (105)	15.12 (384)	11.56 (294)	14.00 (356)	6.68 (170)	17.76 (451)	20.20 (513)	12.21 (310)	14.00 (356)	6.68 (170)	18.41 (468)	20.20 (513)	
Z35	9.80 (249)	4.69 (119)	16.17 (410)	12.31 (313)	14.00 (356)	7.19 (183)	18.68 (474)	20.36 (517)	12.96 (329)	14.00 (356)	7.19 (183)	19.33 (490)	20.36 (517)	
	A	B	C	D		E	F		G		H	J		
				Std.	16"		Std.	16"	Std.	16"		Std.	16"	
K35	12.04 (306)	5.68 (144)	18.92 (481)	14.56 (370)	16.00 (406)	8.19 (208)	21.45 (545)	22.89 (581)	15.21 (386)	16.00 (406)	8.19 (208)	22.10 (561)	22.89 (581)	

CHAMBERS WITH 1½-INCH CONNECTIONS — 150 LB. AND 300 LB. ANSI CLASS

Model Code*	1½" NPT Threaded & Socket Weld			1½" Flanged Upper Side/Bottom					1½" Flanged Side/Side					
	A	B	C	D		E	F		G		H	J		
				Std.	14"		Std.	14"	Std.	14"		Std.	14"	
B35	8.92 (227)	4.22 (107)	15.12 (384)	12.56 (319)	14.00 (356)	7.69 (195)	18.76 (477)	20.20 (513)	13.21 (336)	14.00 (356)	7.69 (195)	19.41 (493)	20.20 (513)	
C35	8.92 (227)	4.22 (107)	15.12 (384)	12.56 (319)	14.00 (356)	7.69 (195)	18.76 (477)	20.20 (513)	13.21 (336)	14.00 (356)	7.69 (195)	19.41 (493)	20.20 (513)	
G35	9.80 (249)	4.75 (121)	16.17 (410)	13.31 (338)	14.00 (356)	8.19 (208)	19.68 (500)	20.36 (517)	13.96 (355)	14.00 (356)	8.19 (208)	20.33 (516)	20.36 (517)	
L35	9.80 (249)	4.75 (121)	16.17 (410)	13.31 (338)	14.00 (356)	8.19 (208)	19.68 (500)	20.36 (517)	13.96 (355)	14.00 (356)	8.19 (208)	20.33 (516)	20.36 (517)	
V35	8.92 (227)	4.22 (107)	15.12 (384)	12.56 (319)	14.00 (356)	7.69 (195)	18.76 (477)	20.20 (513)	13.21 (336)	14.00 (356)	7.69 (195)	19.41 (493)	20.20 (513)	
Z35	9.80 (249)	4.75 (121)	16.17 (410)	13.31 (338)	14.00 (356)	8.19 (208)	19.68 (500)	20.36 (517)	13.96 (355)	14.00 (356)	8.19 (208)	20.33 (516)	20.36 (517)	
	A	B	C	D		E	F		G		H	J		
				Std.	16"		Std.	16"	Std.	16"		Std.	16"	
K35	12.04 (306)	5.75 (146)	18.92 (481)	15.56 (395)	16.00 (406)	9.19 (233)	22.45 (570)	22.89 (581)	16.21 (412)	16.00 (406)	9.19 (233)	23.10 (587)	22.89 (581)	

CHAMBERS WITH 2-INCH CONNECTIONS — 150 LB. AND 300 LB. ANSI CLASS

Model Code*	2" NPT Threaded & Socket Weld			2" Flanged Upper Side/Bottom					2" Flanged Side/Side					
	A	B	C	D		E	F		G		H	J		
				Std.	14"		Std.	14"	Std.	14"		Std.	14"	
B35	8.92 (227)	4.34 (110)	15.12 (384)	12.56 (319)	14.00 (356)	7.69 (195)	18.76 (477)	20.20 (513)	13.21 (336)	14.00 (356)	7.69 (195)	19.41 (493)	20.20 (513)	
C35	8.92 (227)	4.34 (110)	15.12 (384)	12.56 (319)	14.00 (356)	7.69 (195)	18.76 (477)	20.20 (513)	13.21 (336)	14.00 (356)	7.69 (195)	19.41 (493)	20.20 (513)	
G35	9.80 (249)	4.88 (124)	16.17 (410)	13.31 (338)	14.00 (356)	8.19 (208)	19.68 (500)	20.36 (517)	13.96 (355)	14.00 (356)	8.19 (208)	20.33 (516)	20.36 (517)	
L35	9.80 (249)	4.88 (124)	16.17 (410)	13.31 (338)	14.00 (356)	8.19 (208)	19.68 (500)	20.36 (517)	13.96 (355)	14.00 (356)	8.19 (208)	20.33 (516)	20.36 (517)	
V35	8.92 (227)	4.34 (110)	15.12 (384)	12.56 (319)	14.00 (356)	7.69 (195)	18.76 (477)	20.20 (513)	13.21 (336)	14.00 (356)	7.69 (195)	19.41 (493)	20.20 (513)	
Z35	9.80 (249)	4.88 (124)	16.17 (410)	13.31 (338)	14.00 (356)	8.19 (208)	19.68 (500)	20.36 (517)	13.96 (355)	14.00 (356)	8.19 (208)	20.33 (516)	20.36 (517)	
	A	B	C	D		E	F		G		H	J		
				Std.	16"		Std.	16"	Std.	16"		Std.	16"	
K35	12.04 (306)	5.88 (149)	18.92 (481)	15.56 (395)	16.00 (406)	9.19 (233)	22.45 (570)	22.89 (581)	16.21 (412)	16.00 (406)	9.19 (233)	23.10 (587)	22.89 (581)	

* Model B34 is not available for chambers with 1½" and 2" connections

5.2 Specifications

5.2.2 Dimensional Specifications — Flanged Cage Models

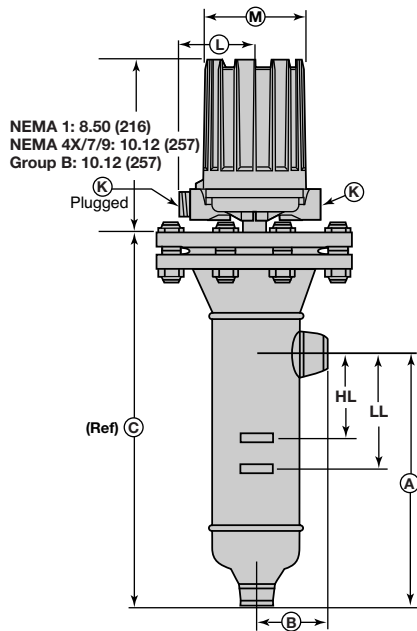

Figure 15
Threaded & Socket Weld
Upper Side/Bottom

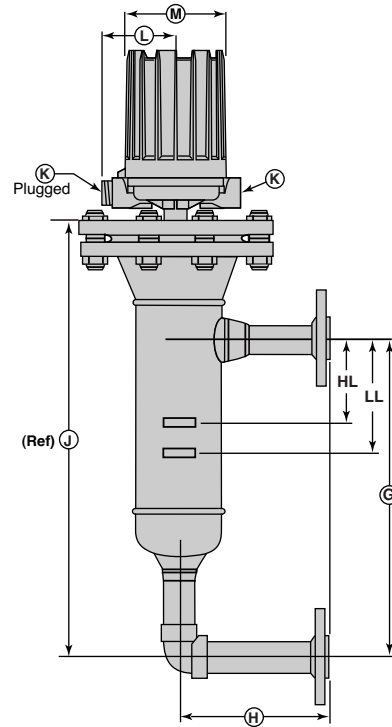

Figure 16
Flanged Side/Side

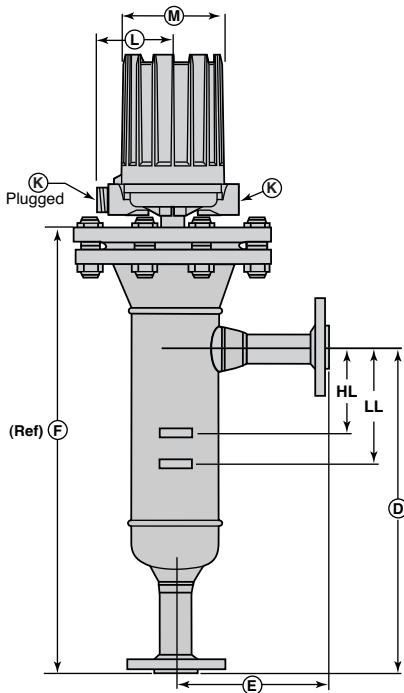

Figure 17
Flanged Upper Side/Bottom

Conduit Connections K

Electrical Switches	
NEMA 4X/7/9:	1" NPT
Group B:	1" NPT
Pneumatic Switches	
NEMA 1:	¼" NPT

Actuation levels

Outline Dimensions	L	M
NEMA 4X/7/9	3.87	5.93
NEMA 4X/7/9, Group B	(98)	(151)
NEMA 1	5.00	4.62
	(127)	(117)

Allow 8" (203 mm) over head clearance for cover removal.

All housings rotatable 360°.

5.2 Specifications

5.2.2 Dimensional Specifications – Flanged Cage Models (cont.)

Inches (mm)

CHAMBERS WITH 1-INCH CONNECTIONS

Model Code	Head Flg. Rating (lbs.)	1" NPT Threaded & Socket Weld			1" Flanged Upper Side/Bottom					1" Flanged Side/Side				
		A	B	C	D		E	F		G		H	J	
					Std.	14"		Std.	14"	Std.	14"		Std.	14"
C34	300	15.63 (397)	3.13 (80)	22.59 (574)	18.33 (466)	—	5.45 (138)	25.29 (642)	—	18.97 (482)	—	5.45 (138)	25.93 (659)	—
	600	15.63 (397)	3.13 (80)	22.72 (577)	18.33 (466)	—	5.45 (138)	25.42 (646)	—	18.97 (482)	—	5.45 (138)	26.06 (662)	—
B3F	150	9.12 (232)	3.63 (92)	16.64 (423)	12.06 (306)	14.00 (356)	6.13 (156)	19.58 (497)	21.51 (546)	12.71 (323)	14.00 (356)	6.13 (156)	20.23 (514)	21.51 (546)
	300	9.12 (232)	3.63 (92)	17.32 (440)	12.06 (306)	14.00 (356)	6.13 (156)	20.26 (515)	22.19 (564)	12.71 (323)	14.00 (356)	6.13 (156)	20.91 (531)	22.19 (564)
	600	9.12 (232)	3.63 (92)	18.45 (469)	12.06 (306)	14.00 (356)	6.13 (156)	21.39 (543)	23.32 (592)	12.71 (323)	14.00 (356)	6.13 (156)	22.04 (560)	23.32 (592)
G3F	150	10.12 (257)	4.69 (119)	18.30 (465)	13.06 (332)	14.00 (356)	7.19 (183)	21.25 (540)	22.19 (564)	13.71 (348)	14.00 (356)	7.19 (183)	21.89 (556)	22.17 (563)
	300	10.12 (257)	4.69 (119)	19.12 (486)	13.06 (332)	14.00 (356)	7.19 (183)	22.06 (560)	23.00 (584)	13.71 (348)	14.00 (356)	7.19 (183)	22.71 (577)	23.00 (584)
	600	10.12 (257)	4.69 (119)	20.56 (522)	13.06 (332)	14.00 (356)	7.19 (183)	23.50 (597)	24.44 (621)	13.71 (348)	14.00 (356)	7.19 (183)	24.15 (613)	24.43 (621)
Z3F	600	10.11 (257)	4.68 (119)	20.19 (513)	13.06 (332)	14.00 (356)	7.19 (183)	23.14 (588)	24.08 (612)	13.71 (348)	14.00 (356)	7.18 (182)	23.79 (604)	24.08 (612)
	900	10.11 (257)	4.68 (119)	21.13 (537)	13.06 (332)	14.00 (356)	7.19 (183)	23.14 (588)	24.08 (612)	13.71 (348)	14.00 (356)	7.18 (182)	23.79 (604)	24.08 (612)
		A	B	C	D		E	F		G		H	J	
					Std.	16"		Std.	16"	Std.	16"		Std.	16"
K3F	150	11.62 (295)	5.69 (145)	20.38 (518)	14.56 (370)	16.00 (406)	8.19 (208)	23.33 (593)	24.77 (629)	15.21 (386)	16.00 (406)	8.19 (208)	23.98 (609)	24.77 (629)
	300	11.62 (295)	5.69 (145)	21.25 (540)	14.56 (370)	16.00 (406)	8.19 (208)	24.20 (615)	25.64 (651)	15.21 (386)	16.00 (406)	8.19 (208)	24.85 (631)	25.64 (651)
	600	11.62 (295)	5.69 (145)	22.93 (582)	14.56 (370)	16.00 (406)	8.19 (208)	25.88 (657)	27.32 (694)	15.21 (386)	16.00 (406)	8.19 (208)	26.53 (674)	27.32 (694)

CHAMBERS WITH 1½-INCH CONNECTIONS

Model Code	Head Flg. Rating (lbs.)	1" NPT Threaded & Socket Weld			1" Flanged Upper Side/Bottom					1" Flanged Side/Side				
		A	B	C	D		E	F		G		H	J	
					Std.	14"		Std.	14"	Std.	14"		Std.	14"
C34	300	15.63 (397)	3.19 (81)	22.59 (574)	18.33 (466)	—	6.19 (157)	25.29 (642)	—	18.97 (482)	—	6.19 (157)	25.93 (659)	—
	600	15.63 (397)	3.19 (81)	22.72 (577)	18.33 (466)	—	6.19 (157)	25.42 (646)	—	18.97 (482)	—	6.19 (157)	26.06 (662)	—
B3F	150	9.12 (232)	3.69 (94)	16.64 (423)	13.06 (332)	14.00 (356)	7.13 (181)	20.58 (523)	21.51 (546)	13.71 (348)	14.00 (356)	7.13 (181)	21.23 (539)	21.51 (546)
	300	9.12 (232)	3.69 (94)	17.32 (440)	13.06 (332)	14.00 (356)	7.13 (181)	21.26 (540)	22.19 (564)	13.71 (348)	14.00 (356)	7.13 (181)	21.91 (556)	22.19 (564)
	600	9.12 (232)	3.69 (94)	18.45 (469)	13.06 (332)	14.00 (356)	7.13 (181)	22.39 (568)	23.32 (592)	13.71 (348)	14.00 (356)	7.13 (181)	23.04 (585)	23.32 (592)
G3F	150	10.12 (257)	4.75 (121)	18.30 (465)	14.06 (357)	14.00 (356)	8.19 (208)	22.25 (565)	22.19 (564)	14.71 (374)	14.00 (356)	8.19 (208)	22.89 (581)	22.19 (564)
	300	10.12 (257)	4.75 (121)	19.12 (486)	14.06 (357)	14.00 (356)	8.19 (208)	23.06 (586)	23.00 (584)	14.71 (374)	14.00 (356)	8.19 (208)	23.71 (602)	23.00 (584)
	600	10.12 (257)	4.75 (121)	20.56 (522)	14.06 (357)	14.00 (356)	8.19 (208)	24.50 (622)	24.44 (621)	14.71 (374)	14.00 (356)	8.19 (208)	25.15 (639)	24.44 (621)
Z3F	600	10.11 (257)	4.75 (121)	20.19 (513)	14.06 (357)	14.00 (356)	8.18 (208)	24.14 (613)	24.08 (612)	14.71 (374)	14.00 (356)	8.18 (208)	24.79 (630)	24.08 (612)
	900	10.11 (257)	4.75 (121)	21.13 (537)	14.06 (357)	14.00 (356)	8.18 (208)	24.14 (613)	24.08 (612)	14.71 (374)	14.00 (356)	8.18 (208)	24.79 (630)	24.08 (612)
		A	B	C	D		E	F		G		H	J	
					Std.	16"		Std.	16"	Std.	16"		Std.	16"
K3F	150	11.62 (295)	5.75 (146)	20.38 (518)	15.56 (395)	16.00 (406)	9.19 (233)	24.33 (618)	24.77 (629)	16.21 (412)	16.00 (406)	9.19 (233)	24.98 (634)	24.77 (629)
	300	11.62 (295)	5.75 (146)	21.25 (540)	15.56 (395)	16.00 (406)	9.19 (233)	25.50 (648)	25.64 (651)	16.21 (412)	16.00 (406)	9.19 (233)	25.85 (657)	25.64 (651)
	600	11.62 (295)	5.75 (146)	22.93 (582)	15.56 (395)	16.00 (406)	9.19 (233)	26.88 (683)	27.32 (694)	16.21 (412)	16.00 (406)	9.19 (233)	27.53 (699)	27.32 (694)

5.2 Specifications

5.2.2 Dimensional Specifications – Flanged Cage Models (cont.)

Inches (mm)

CHAMBERS WITH 2-INCH CONNECTIONS

Model Code	Head Flg. Rating (lbs.)	2" NPT Threaded & Socket Weld			2" Flanged Upper Side/Bottom					2" Flanged Side/Side				
		A	B	C	D		E	F		G		H	J	
					Std.	14"		Std.	14"	Std.	14"		Std.	14"
C34	300	15.63 (397)	3.31 (84)	22.59 (574)	18.33 (466)	—	6.25 (159)	25.29 (642)	—	18.97 (482)	—	6.25 (159)	25.93 (659)	—
	600	15.63 (397)	3.31 (84)	22.72 (577)	18.33 (466)	—	6.25 (159)	25.42 (646)	—	18.97 (482)	—	6.25 (159)	26.06 (662)	—
B3F	150	9.12 (232)	3.81 (97)	16.64 (423)	13.06 (332)	14.00 (356)	7.13 (181)	20.58 (523)	21.51 (546)	13.71 (348)	14.00 (356)	7.13 (181)	21.23 (539)	21.51 (546)
	300	9.12 (232)	3.81 (97)	17.32 (440)	13.06 (332)	14.00 (356)	7.13 (181)	21.26 (540)	22.19 (564)	13.71 (348)	14.00 (356)	7.13 (181)	21.91 (556)	22.19 (564)
	600	9.12 (232)	3.81 (97)	18.45 (469)	13.06 (332)	14.00 (356)	7.13 (181)	22.39 (568)	23.32 (592)	13.71 (348)	14.00 (356)	7.13 (181)	23.04 (585)	23.32 (592)
G3F	150	10.12 (257)	4.88 (124)	18.30 (465)	14.06 (357)	14.00 (356)	8.19 (208)	22.25 (565)	22.19 (564)	14.71 (374)	14.00 (356)	8.19 (208)	22.89 (581)	22.19 (564)
	300	10.12 (257)	4.88 (124)	19.12 (486)	14.06 (357)	14.00 (356)	8.19 (208)	23.06 (586)	23.00 (584)	14.71 (374)	14.00 (356)	8.19 (208)	23.71 (602)	23.00 (584)
	600	10.12 (257)	4.88 (124)	20.56 (522)	14.06 (357)	14.00 (356)	8.19 (208)	24.50 (622)	24.44 (621)	14.71 (374)	14.00 (356)	8.19 (208)	25.15 (639)	24.44 (621)
Z3F	600	10.11 (257)	4.87 (124)	20.19 (513)	14.06 (357)	14.00 (356)	8.18 (208)	24.14 (613)	24.08 (612)	14.71 (374)	14.00 (356)	8.18 (208)	24.79 (630)	24.08 (612)
	900	10.11 (257)	4.87 (124)	21.13 (537)	14.06 (357)	14.00 (356)	8.18 (208)	24.14 (613)	24.08 (612)	14.71 (374)	14.00 (356)	8.18 (208)	24.79 (630)	24.08 (612)
		A	B	C	D		E	F		G		H	J	
					Std.	16"		Std.	16"	Std.	16"		Std.	16"
K3F	150	11.62 (295)	5.88 (149)	20.38 (518)	15.56 (395)	16.00 (406)	9.19 (233)	24.33 (618)	24.77 (629)	16.21 (412)	16.00 (406)	9.19 (233)	24.98 (634)	24.77 (629)
	300	11.62 (295)	5.88 (149)	21.25 (540)	15.56 (395)	16.00 (406)	9.19 (233)	25.20 (648)	25.64 (651)	16.21 (412)	16.00 (406)	9.19 (233)	25.85 (657)	25.64 (651)
	600	11.62 (295)	5.88 (149)	22.93 (582)	15.56 (395)	16.00 (406)	9.19 (233)	26.88 (683)	27.32 (694)	16.21 (412)	16.00 (406)	9.19 (233)	27.53 (699)	27.32 (694)

5.2 Specifications

5.2.3 Actuating Levels* and Specific Gravities

For float operated units, minimum specific gravities and actuating levels vary depending upon the material of construction code used with the unit.

NOTE: The minimum specific gravities and actuating levels shown are for single switch units with 1" process connections only. Minimum specific gravities and levels will change for multistage units and levels will change for units with 1½ or 2" process connections. Consult factory for these changes.

*The level decals on the control identify the actuation levels for units with three switches at the corresponding minimum specific gravity of the three switch configuration.

Inches (mm)

SEALED CAGE FLOAT MODELS WITH 1-INCH PROCESS CONNECTIONS

Model Code	Models w/Materials of Construction Code 1			Models w/Materials of Construction Code 2		
	Minimum Specific Gravity	Actuating Level @ Minimum Specific Gravity		Minimum Specific Gravity	Actuating Level @ Minimum Specific Gravity	
		HL	LL		HL	LL
B35	0.69	3.06 (78)	3.62 (92)	0.72	3.06 (78)	3.79 (96)
C35	0.57	3.15 (80)	3.86 (98)	0.59	3.09 (78)	3.96 (101)
G35	0.55	3.25 (82)	3.83 (97)	0.56	3.20 (81)	3.90 (99)
K35	0.40	3.56 (90)	4.06 (103)	0.40	3.40 (86)	4.02 (102)
L35	0.41	3.31 (84)	3.98 (101)	0.43	3.34 (85)	4.14 (105)
V35	0.71	3.06 (78)	3.81 (97)	0.75	3.00 (76)	3.64 (92)
Z35	0.66	2.94 (75)	3.63 (92)	0.68	2.90 (74)	3.47 (88)

FLANGED CAGE FLOAT MODELS WITH 1-INCH PROCESS CONNECTIONS

Model Code	Head Flange (Lbs.)	Models w/Materials of Construction Code 1			Models w/Materials of Construction Code 2 or N		
		Minimum Specific Gravity	Actuating Level @ Minimum Specific Gravity		Minimum Specific Gravity	Actuating Level @ Minimum Specific Gravity	
			HL	LL		HL	LL
B3F	150	0.78	3.00 (76)	3.87 (98)	0.83	2.97 (75)	4.05 (103)
	300	0.66	2.17 (55)	2.97 (75)	0.66	2.10 (53)	3.10 (79)
	600	0.66	2.06 (52)	3.12 (79)	0.71	2.19 (56)	2.94 (75)
G3F	150	0.41	3.58 (91)	4.26 (108)	0.43	3.61 (92)	4.42 (112)
	300	0.55	3.52 (89)	4.10 (104)	0.56	3.47 (88)	4.18 (106)
	600	0.70	4.00 (102)	4.81 (122)	0.76	4.13 (105)	4.75 (121)
K3F	150	0.33	3.08 (78)	3.64 (92)	0.33	2.97 (75)	3.67 (112)
	300	0.40	3.05 (77)	3.56 (90)	0.40	2.96 (75)	3.57 (93)
	600	0.60	3.30 (84)	3.85 (98)	0.62	3.44 (87)	3.88 (99)
Z3F	600	0.67	3.10 (79)	3.80 (97)	0.70	3.12 (79)	3.68 (93)
	900	0.67	3.10 (79)	3.80 (97)	0.70	3.12 (79)	3.68 (93)

5.2 Specifications

5.2.3 Actuating Levels*, Steam Service Ratings and Specific Gravities (cont.)

Inches (mm)

DISPLACER MODELS WITH 1-INCH PROCESS CONNECTIONS

		Liquid Specific Gravity													
Model Code	Process Temp. ° F (° C)	0.40		0.50		0.60		0.70		0.80		0.90		1.00	
		HL	LL	HL	LL	HL	LL	HL	LL	HL	LL	HL	LL	HL	LL
B34	100 (38)	1.30 (33)	4.77 (121)	2.17 (55)	5.00 (127)	2.73 (69)	5.16 (131)	3.13 (80)	5.28 (134)	3.44 (87)	5.37 (136)	3.67 (93)	5.45 (138)	3.86 (98)	5.51 (140)
	200 (93)	1.24 (31)	4.70 (119)	2.13 (54)	4.95 (126)	2.70 (69)	5.11 (130)	3.11 (79)	5.24 (133)	3.42 (87)	5.34 (136)	3.66 (93)	5.41 (137)	3.85 (98)	5.48 (139)
	300 (149)	1.18 (30)	4.62 (117)	2.09 (53)	4.88 (124)	2.67 (68)	5.06 (129)	3.09 (78)	5.19 (132)	3.40 (86)	5.30 (135)	3.64 (92)	5.38 (137)	3.84 (98)	5.45 (138)
C34	100 (38)	4.56 (116)	8.44 (214)	5.75 (146)	8.94 (227)	6.56 (167)	9.25 (235)	7.13 (181)	9.50 (241)	7.50 (191)	9.69 (246)	7.88 (200)	9.81 (249)	8.13 (207)	9.94 (252)
	200 (93)	4.19 (106)	8.06 (205)	5.50 (140)	8.63 (219)	6.31 (160)	9.00 (229)	6.94 (176)	9.25 (235)	7.38 (187)	9.50 (241)	7.69 (195)	9.63 (245)	8.00 (203)	9.75 (248)
	300 (149)	3.81 (97)	7.63 (194)	5.19 (132)	8.25 (210)	6.06 (154)	8.69 (221)	6.69 (170)	9.00 (229)	7.19 (183)	9.25 (235)	7.50 (191)	9.44 (240)	7.81 (198)	9.56 (243)
	400 (205)	n/a	n/a	4.81 (122)	7.88 (200)	5.75 (146)	8.38 (213)	6.44 (164)	8.75 (222)	6.94 (176)	9.00 (229)	7.31 (186)	9.25 (235)	7.63 (194)	9.38 (238)
	500 (260)	n/a	n/a	4.44 (113)	7.44 (189)	5.44 (138)	8.00 (203)	6.19 (157)	8.44 (214)	6.69 (170)	8.75 (222)	7.13 (181)	9.25 (229)	7.44 (189)	9.19 (233)

5.3 Replacement Parts

5.3.1 Sealed Cage Float Models B35, C35, G35, K35, L35, V35 and Z35 Parts Identification

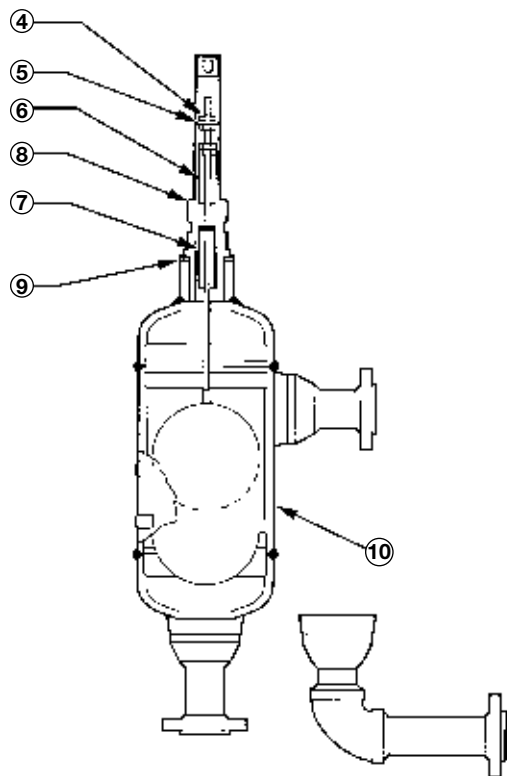

Figure 19

Sealed Cage Models B35, C35, G35, K35, L35

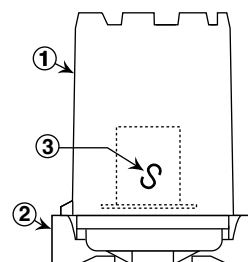

Figure 18

Housing and Switch Mechanism

Item	Description
1	Housing cover
2	Housing base
3	Switch mechanism
4	Jam nuts (qty. 4)
5	Washer
6	Attraction sleeve
7	Stop tube
8	Enclosing tube ①
9	E-tube gasket
10	Chamber assembly

5.3.2 Sealed Cage Float Models B35, C35, G35, K35, L35, V35 and Z35 Part Numbers

	B35, C35, G35, K35 & L35		V35 & Z35	
	Material Code	Material Code	Material Code	Material Code
	1	2	1	2
Housing kit (includes items 1 and 2)	Refer to bulletin on switch mechanism and housing base assembly furnished (see page 7)			
Switch mechanism	Refer to bulletin on switch mechanism and housing base assembly furnished (see page 7)			
Sleeve kit (includes items 4 through 7)	89-3426-001	89-3426-002	89-3426-005	89-3426-006
Enclosing tube ①	Z32-6346-002	Z32-6346-202	Z32-6346-003	Z32-6346-203
E-tube gasket	12-1204-001			
Chamber assembly*	Available as complete sensing units only			

① An enclosing tube order must also include an E-tube gasket order.

* Specify model and serial number of control when ordering.

5.3 Replacement Parts

5.3.3 Sealed Cage Displacer Models B34 Parts Identification

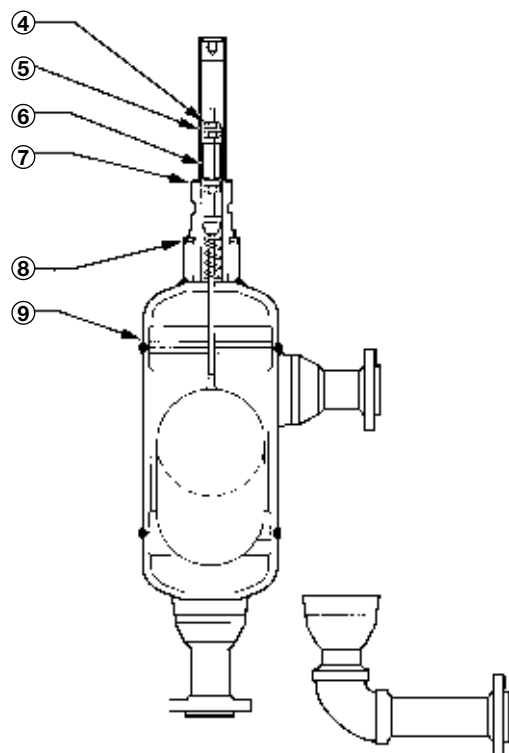

Item	Description
1	Housing cover
2	Housing base
3	Switch mechanism
4	Jam nuts (qty. 5)
5	Washer
6	Attraction sleeve
7	Stop tube
8	Enclosing tube ①
9	E-tube gasket
10	Chamber assembly

Figure 20

Sealed Cage Displacer Model B34

5.3.4 Sealed Cage Displacer Models B34 Part Numbers

	All models w/Material Code 1	All models w/Material Code 2
Housing kit (includes items 1 and 2)	Refer to bulletin on switch mechanism and housing base assembly furnished (see page 7)	
Switch mechanism	Refer to bulletin on switch mechanism and housing base assembly furnished (see page 7)	
Sleeve kit (includes items 4 through 6)	89-3426-003	89-3426-004
Enclosing tube ①	Z32-6346-001	Z32-6346-201
E-tube gasket	12-1204-001	
Chamber assembly*	Available as complete sensing units only	

① An enclosing tube order must also include an E-tube gasket order.

* Specify model and serial number of control when ordering.

5.3 Replacement Parts

5.3.5 Flanged Cage Displacer Model C34 Parts Identification

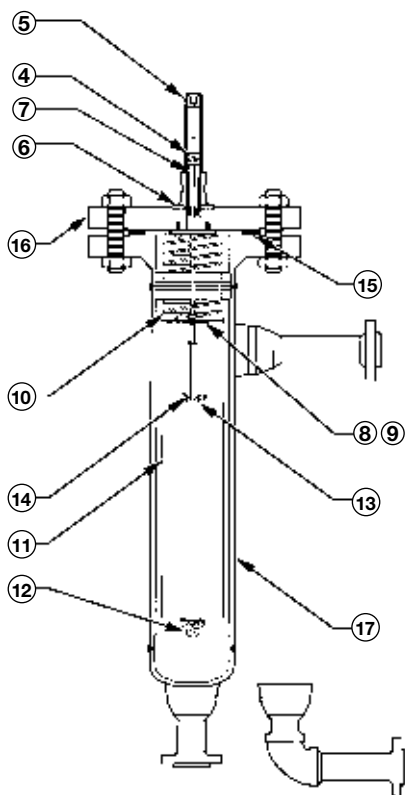

Figure 21

Flanged Cage Displacer Model C34

Item	Description
1	Housing cover
2	Housing base
3	Switch mechanism
4	Jam nuts (qty. 5)
5	Enclosing tube ①
6	E-tube gasket
7	Attraction sleeve
8	Washer (qty. 3)
9	Screws (qty. 3)
10	Spring & stem assembly
11	Displacer assembly
12	Retainer
13	Washer
14	Cotter pin (qty. 2)
15	Head flange gasket
16	Head flange ②
17	Chamber assembly

5.3.6 Flanged Cage Displacer Model C34 Part Numbers

	All models w/Material Code 1	All models w/Material Code 2	All models w/Material Code N
Housing kit (includes items 1 and 2)	Refer to bulletin on switch mechanism and housing base assembly furnished (see page 7)		
Switch mechanism	Refer to bulletin on switch mechanism and housing base assembly furnished (see page 7)		
Jam nuts	10-2106-004	10-2107-001	10-2107-001
Enclosing tube ①	300# rating Z32-6346-201	Z32-6346-201	Z32-6339-002
	600# rating Z32-6346-204	Z32-6346-204	Z32-6339-001
E-tube gasket	12-1204-001		
Attraction sleeve	300# rating 32-4205-002	32-4511-202	
	600# rating 32-4203-004	32-4511-201	
Displacer and stem kits			
(includes items 8 through 15)	300# rating 89-3258-001	89-3258-003	Consult factory
	600# rating 89-3258-002	89-3258-004	Consult factory
Head flange ②	300# rating	Z04-8639-001	
	600# rating	Z04-8639-002	
Chamber assembly*	Consult factory		

① An enclosing tube order must also include an E-tube gasket order.

② A head flange order must also include a head flange gasket order. Consult factory for part number.

* Specify model and serial number of control when ordering.

5.3 Replacement Parts

5.3.7 Flanged Cage Float Models B3F, G3F, K3F and Z3F w/Material Code 1 Parts Identification

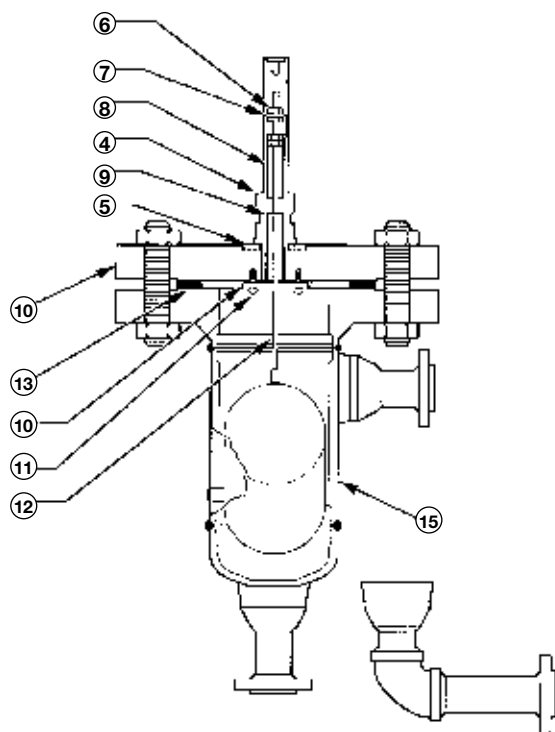

Figure 22

Flanged Cage Models B3F, G3F, K3F and Z3F

Item	Description
1	Housing cover
2	Housing base
3	Switch mechanism
4	Enclosing tube ①
5	E-tube gasket
6	Jam nuts (qty. 4)
7	Washer (qty. 2)
8	Attraction sleeve
9	Stop tube
10	Stop strap
11	Screws (qty. 2)
12	Float & stem assembly
13	Head flange gasket
14	Head flange ②
15	Chamber assembly

5.3.8 Flanged Cage Float Models B3F, G3F, K3F and Z3F w/Material Code 1 Part Numbers

		150# Head Flange	300# Head Flange	600# Head Flange	900# Head Flange
Housing kit		Refer to bulletin on switch mechanism and housing base assembly furnished (see page 7)			
(includes items 1 and 2)		assembly furnished (see page 7)			
Switch mechanism		Refer to bulletin on switch mechanism and housing base assembly furnished (see page 7)			
Enclosing tube ① (Codes 1, 2)		Z32-6346-002	Z32-6346-002	Z32-6346-003	Z32-6346-003
Enclosing tube (Code N)		Z32-6339-004	Z32-6339-004	Z32-6339-005	n/a
E-tube gasket		12-1204-001			
Head Flange Gasket	B3F	12-1204-024	12-1204-012	12-1204-002	n/a
	G3F	12-1204-025	12-1204-013	12-1204-028	n/a
	K3F	12-1204-026	12-1204-027	12-1204-029	n/a
	Z3F	n/a	n/a	12-1204-028	12-1204-047
Float & Stem Kits (includes items 6 through 13)	B3F	89-3258-005	89-3258-008	89-3258-011	n/a
	G3F	89-3258-006	89-3258-009	89-3258-012	n/a
	K3F	89-3258-007	89-3258-010	89-3258-013	n/a
	Z3F	n/a	n/a	89-3258-023	89-3258-024
Head Flange	B3F	Z04-8637-001	Z04-8637-002	Z04-8637-003	n/a
	G3F	Z04-8637-004	Z04-8637-005	Z04-8637-006	n/a
	K3F	Z04-8637-007	Z04-8637-008	Z04-8637-009	n/a
	Z3F	n/a	n/a	Z04-8637-006	Z04-8637-013
Chamber assembly*		Consult factory			

① An enclosing tube order must also include an E-tube gasket order.

② A head flange order must also include a head flange gasket order. Consult factory for part number.

* Specify model and serial number of control when ordering.

5.3 Replacement Parts

5.3.9 Flanged Cage Float Models B3F, G3F, K3F and Z3F w/Material Codes 2 & N Parts Identification

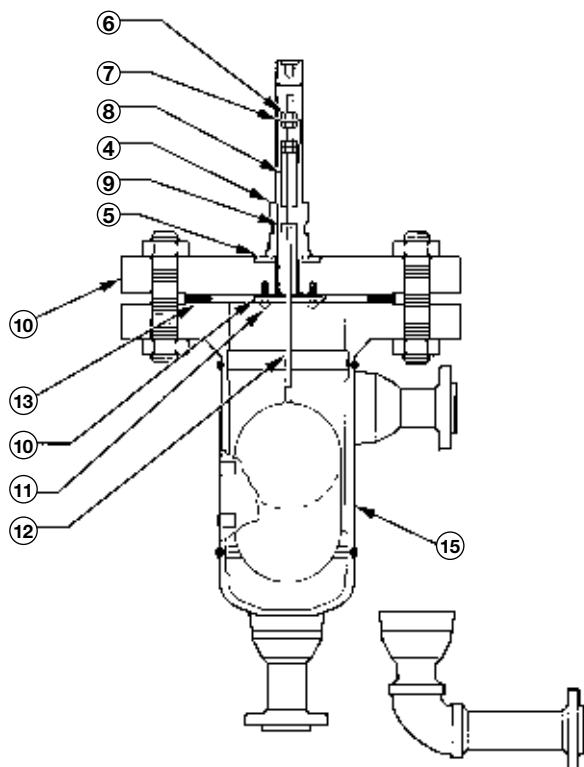

Item	Description
1	Housing cover
2	Housing base
3	Switch mechanism
4	Enclosing tube ①
5	E-tube gasket
6	Jam nuts (qty. 4)
7	Washer (qty. 2)
8	Attraction sleeve
9	Stop tube
10	Stop strap
11	Screws (qty. 2)
12	Float & stem assembly
13	Head flange gasket
14	Head flange ②
15	Chamber assembly

Figure 23

Flanged Cage Models B3F, G3F, K3F and Z3F

5.3.10 Flanged Cage Float Models B3F, G3F, K3F and Z3F w/Material Codes 2 & N Part Numbers

		150# Head Flange Material Code 2 & N	300# Head Flange Material Code 2 & N	600# Head Flange Material Code 2 & N	900# Head Flange Material Code 2
Housing kit (includes items 1 and 2)		Refer to bulletin on switch mechanism and housing base assembly furnished (see page 7)			
Switch mechanism		Refer to bulletin on switch mechanism and housing base assembly furnished (see page 7)			
Enclosing tube ① (Codes 1, 2)		Z32-6346-202	Z32-6346-202	Z32-6346-203	Z32-6346-203
Enclosing tube (Code N)		Z32-6339-004	Z32-6339-004	Z32-6339-005	n/a
E-tube gasket		12-1204-001			
Head Flange Gasket	B3F	12-1204-024	12-1204-012	12-1204-002	n/a
	G3F	12-1204-025	12-1204-013	12-1204-028	n/a
	K3F	12-1204-026	12-1204-027	12-1204-029	n/a
	Z3F	n/a	n/a	12-1204-028	12-1204-047
Float & Stem Kits (includes items 6 through 13)	B3F	89-3258-014	89-3258-017	89-3258-020	n/a
	G3F	89-3258-015	89-3258-018	89-3258-021	n/a
	K3F	89-3258-016	89-3258-019	89-3258-022	n/a
	Z3F	n/a	n/a	89-3258-025	89-3258-026
Head Flange	B3F	Z04-8637-001	Z04-8637-002	Z04-8637-003	n/a
	G3F	Z04-8637-004	Z04-8637-005	Z04-8637-006	n/a
	K3F	Z04-8637-007	Z04-8637-008	Z04-8637-009	n/a
	Z3F	n/a	n/a	Z04-8637-006	Z04-8637-013
Chamber assembly*		Consult factory			

① An enclosing tube order must also include an E-tube gasket order.

② A head flange order must also include a head flange gasket order.

* Specify model and serial number of control when ordering.

5.4 Model Numbers

5.4.1 Sealed Cage Models

MODEL NUMBER CODE

Model Code	Min. S.G. for Models with Material of Construction Code ①		Pressure Rating ②												
			psig @ ° F						bar @ ° C						
			1	2	100	550	750	800	900	1000	38	288	399	427	482
FLOAT MODELS															
B35	0.69	0.72	1000	870	716	594	—	138	68.9	60.0	49.6	41.0	—	9.5	
C35	0.57	0.59	500	435	400	395	—	138	34.5	30.0	27.6	27.2	—	9.5	
G35	0.54	0.56	750	653	600	593	—	134	51.7	45.0	41.4	40.9	—	9.2	
K35 ③	0.40	0.40	600	522	480	474	—	121	41.4	36.0	33.1	32.7	—	8.3	
L35	0.41	0.43	300	261	240	237	—	134	20.7	18.0	16.5	16.3	—	9.2	
V35 ④	0.71	0.81	2240	1913	1455	1210	728	n/a	154.4	131.9	100.3	83.4	50.2	n/a	
Z35 ④	0.66	0.71	2193	1913	1425	1185	713	n/a	151.2	131.9	98.3	81.7	49.2	n/a	
DISPLACER MODEL			100	200	300	n/a			38	93	149	n/a			
B34 ③⑤⑥	0.40	0.40	1300	1225	1145	n/a			89.6	84.4	78.9	n/a			

MATERIALS OF CONSTRUCTION

1	Carbon steel chamber, 316L stainless steel float, 400 stainless steel sleeve, ASME B31.3 Construction
2	Carbon steel chamber, 316L stainless steel float, 316 stainless steel sleeve, ASME B31.3 Construction

TANK CONNECTION TYPE AND SIZE

Type	C/C	Size											
		1"				1½" ⑥				2" ⑥			
Threaded	Std.	B20				C20				D20			
Socket Weld	Std.	B30				C30				D30			
		Cage Mounting ANSI Flange Rating (lbs.)											
		150	300	600	900	150	300	600	900	150	300	600	900
Flanged Upper Side/Bottom	Std.	N30	N40	N50	N60	P30	P40	P50	P60	Q30	Q40	Q50	Q60
	14" ③	N34	N44	N54	N64	P34	P44	P54	P64	Q34	Q44	Q54	Q64
	16" ⑦	N36	N46	N56	N66	P36	P46	P56	P66	Q36	Q46	Q56	Q66
Flanged Side/Side	Std.	S30	S40	S50	S60	T30	T40	T50	S60	V30	V40	V50	V60
	14" ③	S34	S44	S54	S64	T34	T44	T54	S64	V34	V44	V54	V64
	16" ⑦	S36	S46	S56	S66	T36	T46	T56	S66	V36	V46	V56	V66

PNEUMATIC SWITCH MECHANISM AND ENCLOSURE

Switch Description	Maximum Supply Pressure		Maximum Process Temperature		Bleed Orifice Diameter		Models B35, C35, G35, K35 & L35 with Material of Constr. Code 1	Models B34, V35, Z35 & All Models with Material of Constr. Code 2
	psig	bar	° F	° C	inches	mm	NEMA 1	NEMA 1
Series J Bleed Type	100	7	400	204	.063	1.6	JGH	JGF
	60	4	400	204	.094	2.3	JHH	JHF
	60	4	700	371	.055	1.3	JJH	JJF
Series K Non-Bleed	100	7	400	204	—	—	—	KOF
	40	3	400	204	—	—	KOH	—

① Minimum SG ratings apply to single stage units. Consult factory for two and three stage units.

② Models are limited to maximum temperature rating of selected switch mechanism.

③ Consult factory for 14" center-to-center dimensions on models K35 & B34.

④ Models V35 and Z35 contain 17-7 ph stainless steel floats.

⑤ Consult factory for Model B34 above +300° F (+149° C). Available with single switch only.

⑥ Codes 1½" and 2" NPT tank connections are not applicable to the B34 displacer model.

⑦ Codes for a 16" center-to-center dimension are applicable to the K35 model only.

5.4 Model Numbers

5.4.1 Sealed Cage Models (cont.)

ELECTRIC SWITCH MECHANISM AND ENCLOSURE

Switch Description	Process [®] Temperature Range °F (°C)	Contacts	Set Points	Models B35, C35, K35 & L35 with Material of Construction Code 1			Models B34, V35, Z35 & all models with Material of Construction Code 2				
				TYPE 4X/7/9 Aluminum Enclosure							
				Class I, Div 1 Groups C&D	Class I, Div 1 Group B	ATEX Ex II 2 G EEx d IIC T6	Class I, Div 1 Groups C&D	Class I, Div 1 Group B	ATEX Ex II 2 G EEx d IIC T6		
Series B Snap Switch	-40 to +250 (-40 to +121)	SPDT	1	BJA	BKJ	BCC	BKB	BKK	BC9		
			2	BLA	BLJ	BDC	BLB	BLK	BD9		
			3	BMA	BMJ	BEC	BMB	BMK	BE9		
		DPDT	1	BNA	BNJ	BFC	BNB	BNK	BF9		
			2	BOA	BOJ	BGC	BOB	BOK	BG9		
Series C Snap Switch	-40 to +450 (-40 to +232)	SPDT	1	CKA	CKJ	CCC	CKB	CKK	CC9		
			2	CLA	CLJ	CDC	CLB	CLK	CD9		
			3	CMA	CMJ	CEC	CMB	CMK	CE9		
		DPDT	1	CNA	CNJ	CFC	CNB	CNK	CF9		
			2	COA	COJ	CGC	COB	COK	CG9		
Series D DC Current Snap Switch	-40 to +250 (-40 to +121)	SPDT	1	DKB	DKK	DC9	DKB	DKK	DC9		
			2	DLB	DLK	DD9	DLB	DLK	DD9		
			3	DMB	DMK	DE9	DMB	DMK	DE9		
		DPDT	1	DNB	DNK	DF9	DNB	DNK	DF9		
			2	DOB	DOK	DG9	DOB	DOK	DG9		
Series F Hermetically Sealed Snap Switch	-50 to +750 (-46 to +399)	SPDT	1	FKA	FKJ	FCC	FKB	FKK	FC9		
			2	FLA	FLJ	FDC	FLB	FLK	FD9		
		DPDT	1	FNA	FNJ	FFC	FNB	FNK	FF9		
			2	FOA	FOJ	FGC	FOB	FOK	FG9		
Series HS [®] Hermetically Sealed 5-amp Snap Switch with Wiring Leads	-50 to +550 [®] (-46 to +288)	SPDT	1	HMJ	HMK	N/A	HMJ	HMK	N/A		
			2	HMN	HMP		HMN	HMP			
		DPDT	1	HMS	HMT		HMS	HMT			
			2	HMY	HMZ		HMY	HMZ			
Series HS [®] Hermetically Sealed 5-amp Snap Switch with Terminal Block	-50 to +550 [®] (-46 to +288)	SPDT	1	HM3	HM4	HA9	HM3	HM4	HA9		
		DPDT	1	HM7	HM8	HB9	HM7	HM8	HB9		
Series H1 [®] Hermetically Sealed 1-amp Snap Switch with Wiring Leads	-50 to +750 (-46 to +399)	SPDT	1	HKJ	HKK	N/A	HKJ	HKK	N/A		
		DPDT	2	HKN	HKP		HKN	HKP			
Series R High Temperature Snap Switch	-40 to +750 (-40 to +399)	SPDT	1	RKB	RKK	RC9	RKB	RKK	RC9		
			2	RLB	RLK	RD9	RLB	RLK	RD9		
		DPDT	1	RNB	RNK	RF9	RNB	RNK	RF9		
			2	ROB	ROK	RG9	ROB	ROK	RG9		
Series 8 Hermetically Sealed Snap Switch	-50 to +750 (-46 to +399)	SPDT	1	8KA	8KJ	8CC	8KB	8KK	8C9		
			2	8LA	8LJ	8DC	8LB	8LK	8D9		
			3	8MA	8MJ	8EC	8MB	8MK	8E9		
		DPDT	1	8NA	8NJ	8FC	8NB	8NK	8F9		
			2	8OA	8OJ	8GC	8OB	8OK	8G9		
Series 9 High Temperature Hermetically Sealed Snap Switch	-50 to +750 (-46 to +399)	SPDT	1	9KA	9KJ	9CC	9KB	9KK	9C9		
			2	9LA	9LJ	9DC	9LB	9LK	9D9		
			3	9MA	9MJ	9EC	9MB	9MK	9E9		
		DPDT	1	9NA	9NJ	9FC	9NB	9NK	9F9		
			2	9OA	9OJ	9GC	9OB	9OK	9G9		
Switch Description	Process [®] Temp. Range °F (°C)	Contacts	Set Points	CS/Aluminum		Cast Iron		CS/Aluminum		Cast Iron	
				NEMA 4X	Class I, Div 1 Groups C&D	Class I, Div 1 Group B	NEMA 4X	Class I, Div 1 Groups C&D	Class I, Div 1 Group B		
Series R High Temperature Snap Switch	-40 to +1000 (-40 to +538)	SPDT	1	R1M	RKM	RKW	R1M	RKM	RKW		
			2	R3M	RLM	RLW	R3M	RLM	RLW		
		DPDT	1	RDM	RNM	RNW	RDM	RNM	RNW		
			2	REM	ROM	ROW	REM	ROM	ROW		
Series 9 High Temperature Hermetically Sealed Snap Switch	-50 to +1000 (-46 to +538)	SPDT	1	9AD	9KD	9KV	9AM	9KM	9KW		
			2	9BD	9LD	9LV	9BM	9LM	9LW		
			3	9CD	9MD	9MV	9CM	9MM	9MW		
		DPDT	1	9DD	9ND	9NV	9DM	9NM	9NW		
			2	9ED	9OD	9OV	9EM	9OM	9OW		

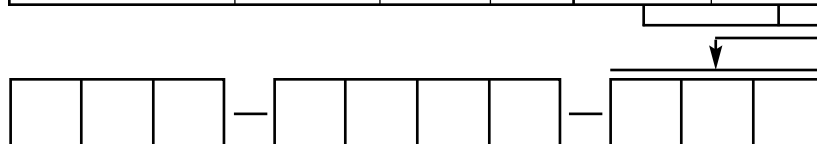

[®] Process temperature based on +100° F (+38° C) ambient.

[®] On condensing applications, temperature down-rated to +400° F (+204° C) process at +100° F (+38° C) ambient.

[®] HS & H1 switches can be used with only materials of construction code 1 on models V35 & Z35

5.4 Model Numbers

5.4.2 Flanged Cage Models

MODEL NUMBER CODE

Model Code	Head Flange ANSI Class	Min. S.G. for Models with Material of Construction Code ^①		Pressure Rating ^②												
				psig @ ° F						bar @ ° C						
				1	2 or N	100	550	750	800	900	1000	38	288	399	427	482
FLOAT MODELS																
B3F	150#	0.78	0.83	285	155	95	80	—	20	19.6	10.7	6.5	5.5	—	1.4	
	300#	0.66	0.68	740	575	505	410	—	50	51.0	39.6	34.8	28.3	—	3.4	
	600# ^{③④}	0.66	0.71	1000	870	800	790	—	105	68.9	60.0	55.6	54.5	—	7.2	
G3F	150#	0.41	0.43	285	155	95	80	—	20	19.6	10.7	6.5	5.5	—	1.4	
	300#	0.55	0.56	740	653	600	410	—	50	51.0	45.0	41.1	28.3	—	3.4	
	600# ^{③④}	0.70	0.76	1000	870	800	790	—	105	68.9	60.0	55.6	54.5	—	7.2	
K3F ^⑤	150#	0.33	0.33	285	155	95	80	—	20	19.6	10.7	6.5	5.5	—	1.4	
	300#	0.40	0.40	600	522	480	474	—	50	41.4	36.0	33.1	32.7	—	3.4	
	600# ^{③④⑥}	0.60	0.62	1480	1147	1010	825	345	n/a	102.0	79.1	69.6	56.9	92.7	n/a	
Z3F	600# ^{③④⑥}	0.67	0.74	1480	1147	1010	825	345	n/a	102.0	79.1	69.6	56.9	92.7	n/a	
	900# ^{③④⑥}	0.67	0.73	2193	1718	1425	1185	515	n/a	151.2	118.5	98.3	81.7	35.5	n/a	
DISPLACER MODELS				100	300	500				100	300	500				
C34 ^{⑤⑦⑧}	300#	n/a		740	655	600	n/a			51.0	45.2	41.1	n/a			
	600# ^④			1480	1315	1200				102.0	90.7	82.7				
	Minimum SG			0.40	0.40	0.44				0.40	0.40	0.44				

MATERIALS OF CONSTRUCTION

1	Carbon steel chamber, 316L stainless steel float, 400 stainless steel sleeve, ASME B31.3 Construction
2	Carbon steel chamber, 316L stainless steel float, 316 stainless steel sleeve, ASME B31.3 Construction
N	Carbon steel chamber, 316L stainless steel float, 316 stainless steel sleeve, NACE and ASME B31.3 Construction

NACE construction: float cage is thermally stress relieved after welding, then hardness tested to assure compliance.

TANK CONNECTION TYPE AND SIZE

Connection Type	C/C	Size ^⑧											
		1"				1½"				2"			
		ANSI Head Flange Rating (lbs.)											
		150	300	600	900	150	300	600	900	150	300	600	900
Threaded s/b	Std.	B20	B60	B80	B40	C20	C60	C80	C40	D20	D60	D80	D40
Socket Weld s/b	Std.	B30	B70	B90	B50	C30	C70	C90	C50	D30	D70	D90	D50
Flanged Upper Side/Bottom	Std.	N30	N40	N50	N60	P30	P40	P50	P60	Q30	Q40	Q50	Q60
	14"⑤	N34	N44	N54	N64	P34	P44	P54	P64	Q34	Q44	Q54	Q64
Flanged Side/Side	16"⑤	N36	N46	N56	N66	P36	P46	P56	P66	Q36	Q46	Q56	Q66
	Std.	S30	S40	S50	S60	T30	T40	T50	T60	V30	V40	V50	V60
	14"⑤	S34	S44	S54	S64	T34	T44	T54	T64	V34	V44	V54	V64
	16"⑤	S36	S46	S56	S66	T36	T46	T56	T66	V36	V46	V56	V66

PNEUMATIC SWITCH MECHANISM AND ENCLOSURE

Switch Description	Maximum Supply Pressure		Maximum Process Temperature		Bleed Orifice Diameter		All Models with Material of Construction Code 1 except B3F, C34, K34, G3F & Z3F with 600# or 900# ANSI rating	Model C34 and All Models with Material of Construction Code 2 or N and B3F, G3F, K3F & Z3F with 600# or 900# ANSI rating
	psig	bar	° F	° C	inches	mm	NEMA 1	NEMA 1
Series J Bleed Type	100	7	400	204	.063	1.6	JGH	JGF
	50	4	400	204	.094	2.3	JHH	JHF
	60	4	700	371	.055	1.3	JJH	JJF
Series K Non-Bleed	100	7	400	204	—	—	—	KOF
	40	3	400	204	—	—	KOH	—

① Minimum SG ratings apply to single stage units. Consult factory for two and three stage units.

② Models are limited to maximum temperature rating of selected switch mechanism.

③ 600# and 900# flanged cage models must use switch codes listed under heading "Model C34 & All Models w/Materials of Construction Codes 2 or N and B3F, G3F, K3F & Z3F with 600# or 900# ANSI rating".

④ HS switches can be used with Materials of Construction Code 1 only. Example: B3F-1B80-HSG.

⑤ Consult factory for 14" center-to-center dimensions on models K3F and C34.

⑥ Construction Code N is not applicable to this unit due to 17-7 ph stainless steel float material.

⑦ Consult factory for Model C34 up to +750° F (+399° C).

5.4 Model Numbers

5.4.2 Flanged Cage Models (cont.)

ELECTRIC SWITCH MECHANISM AND ENCLOSURE

Switch Description	Process [®] Temperature Range °F (°C)	Contacts	Set Points	All models C34 and all models with Material of Construction Code 1 except B3F, G3F, K3F & Z3F with 600# or 900# ANSI ratings			All models C34 and all models with Material of Construction Codes 2 & N and B3F, G3F, K3F & Z3F with 600# or 900# ANSI ratings		
				TYPE 4X/7/9 Aluminum Enclosure					
				Class I, Div 1 Groups C&D	Class I, Div 1 Group B	ATEX Ex II 2 G EEx d IIC T6	Class I, Div 1 Groups C&D	Class I, Div 1 Group B	ATEX Ex II 2 G EEx d IIC T6
Series B Snap Switch	-40 to +250 (-40 to +121)	SPDT	1	BAK	BKJ	BCC	BKB	BKK	BC9
			2	BLA	BLJ	BDC	BLB	BLK	BD9
		DPDT	1	BMA	BMJ	BEC	BMB	BMK	BE9
			2	BNA	BNJ	BFC	BNB	BNK	BF9
Series C Snap Switch	-40 to +450 (-40 to +232)	SPDT	1	CKA	CKJ	CCC	CKB	CKK	CC9
			2	CLA	CLJ	CDC	CLB	CLK	CD9
		DPDT	1	CMA	CMJ	CEC	CMB	CMK	CE9
			2	CNA	CNJ	CFC	CNB	CNK	CF9
Series D DC Current Snap Switch	-40 to +250 (-40 to +121)	SPDT	1	DKB	DKK	DC9	DKB	DKK	DC9
			2	DLB	DLK	DD9	DLB	DLK	DD9
		DPDT	1	DMB	DMK	DE9	DMB	DMK	DE9
			2	DNB	DNK	DF9	DNB	DNK	DF9
Series F Hermetically Sealed Snap Switch	-50 to +750 (-46 to +399)	SPDT	1	FKA	FKJ	FCC	FKB	FKK	FC9
			2	FLA	FLJ	FDC	FLB	FLK	FD9
		DPDT	1	FNA	FNJ	FFC	FNB	FNK	FF9
			2	FOA	FOJ	FGC	FOB	FOK	FG9
Series HS Hermetically Sealed 5-amp Snap Switch with Wiring Leads	-50 to +550 [®] (-46 to +288)	SPDT	1	HMJ	HMK	N/A	HMJ	HMK	N/A
			2	HMN	HMP		HMN	HMP	
		DPDT	1	HMS	HMT		HMS	HMT	
			2	HMY	HMZ		HMY	HMZ	
Series HS Hermetically Sealed 5-amp Snap Switch with Terminal Block	-50 to +550 [®] (-46 to +288)	SPDT	1	HM3	HM4	HA9	HM3	HM4	HA9
		DPDT	1	HM7	HM8	HB9	HM7	HM8	HB9
Series H1 Hermetically Sealed 1-amp Snap Switch with Wiring Leads	-50 to +750 (-46 to +399)	SPDT	1	HKJ	HKK	N/A	HKJ	HKK	N/A
		DPDT	2	HKN	HKP		HKN	HKP	
Series R High Temperature Snap Switch	-40 to +750 (-40 to +399)	SPDT	1	RKB	RKK	RC9	RKB	RKK	RC9
			2	RLB	RLK	RD9	RLB	RLK	RD9
		DPDT	1	RNB	RNK	RF9	RNB	RNK	RF9
			2	ROB	ROK	RG9	ROB	ROK	RG9
Series 8 Hermetically Sealed Snap Switch	-50 to +750 (-46 to +399)	SPDT	1	8KA	8KJ	8CC	8KB	8KK	8C9
			2	8LA	8LJ	8DC	8LB	8LK	8D9
		DPDT	1	8MA	8MJ	8EC	8MB	8MK	8E9
			2	8NA	8NJ	8FC	8NB	8NK	8F9
Series 9 High Temperature Hermetically Sealed Snap Switch	-50 to +750 (-46 to +399)	SPDT	1	9KA	9KJ	9CC	9KB	9KK	9C9
			2	9LA	9LJ	9DC	9LB	9LK	9D9
		DPDT	1	9MA	9MJ	9EC	9MB	9MK	9E9
			2	9NA	9NJ	9FC	9NB	9NK	9F9
Series R High Temperature Snap Switch	-40 to +1000 (-40 to +538)	SPDT	1	R1M	RKM	RKW	R1M	RKM	RKW
			2	R3M	RLM	RLW	R3M	RLM	RLW
		DPDT	1	RDM	RNM	RNW	RDM	RNM	RNW
			2	REM	ROM	ROW	REM	ROM	ROW
Series 9 High Temperature Hermetically Sealed Snap Switch	-50 to +1000 (-46 to +538)	SPDT	1	9AD	9KD	9KV	9AM	9KM	9KW
			2	9BD	9LD	9LV	9BM	9LM	9LW
		DPDT	1	9CD	9MD	9MV	9CM	9MM	9MW
			2	9DD	9ND	9NV	9DM	9NM	9NW
				9ED	9OD	9OV	9EM	9OM	9OW

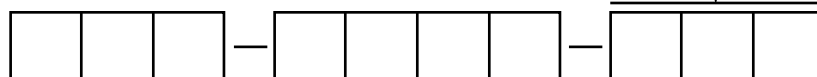

[®] Codes for 150 lb. flanges are not applicable to the C34 displacer model.
[®] Codes for a 16" center-to-center dimension are applicable to the K3F model only.
[®] Process temperature based on +100° F (+38° C) ambient.
[®] On condensing applications, temperature down-rated to +400° F (+204° C) process at +100° F (+38° C) ambient.
[®] On condensing applications, temperature down-rated to +400° F (+204° C) process at +100° F (+38° C) ambient.

NOTES:

NOTES:

Service Policy

Owners of Magnetrol/STI controls may request the return of a control or any part of a control for complete rebuilding or replacement. They will be rebuilt or replaced promptly. Controls returned under our service policy must be returned by Prepaid transportation. Magnetrol/STI will repair or replace the control at no cost to the purchaser (or owner) other than transportation if:

1. Returned within the warranty period; and
2. The factory inspection finds the cause of the claim to be covered under the warranty.

If the trouble is the result of conditions beyond our control; or, is NOT covered by the warranty, there will be charges for labor and the parts required to rebuild or replace the equipment.

In some cases it may be expedient to ship replacement parts; or, in extreme cases a complete new control, to replace the original equipment before it is returned. If this is desired, notify the factory of both the model and serial numbers of the control to be replaced. In such cases, credit for the materials returned will be determined on the basis of the applicability of our warranty.

No claims for misapplication, labor, direct or consequential damage will be allowed.

Return Material Procedure

So that we may efficiently process any materials that are returned, it is essential that a "Return Material Authorization" (RMA) number be obtained from the factory, prior to the material's return. This is available through Magnetrol's or STI's local representative or by contacting the factory. Please supply the following information:

1. Company Name
2. Description of Material
3. Serial Number
4. Reason for Return
5. Application

Any unit that was used in a process must be properly cleaned in accordance with OSHA standards, before it is returned to the factory.

A Material Safety Data Sheet (MSDS) must accompany material that was used in any media.

All shipments returned to the factory must be by prepaid transportation.

All replacements will be shipped F.O.B. factory.



5300 Belmont Road • Downers Grove, Illinois 60515-4499 • 630-969-4000 • Fax 630-969-9489 • www.magnetrol.com
145 Jardin Drive, Units 1 & 2 • Concord, Ontario Canada L4K 1X7 • 905-738-9600 • Fax 905-738-1306
Heikensstraat 6 • B 9240 Zele, Belgium • 052 45.11.11 • Fax 052 45.09.93
Regent Business Ctr., Jubilee Rd. • Burgess Hill, Sussex RH15 9TL U.K. • 01444-871313 • Fax 01444-871317



5300 Belmont Road • Downers Grove, Illinois 60515-4499 • 630-969-4028 • Fax 630-969-9489 • www.sticontrols.com

Copyright © 2009 Magnetrol International, Incorporated. All rights reserved. Printed in the USA.

CSA logotype is a registered trademark of Canadian Standards Association

BULLETIN: 46-622.9
EFFECTIVE: June 2009
SUPERSEDES: June 2008