

**Available For
Quick Delivery**



**Bronze and
Stainless Steel
2-Way**

SOLENOID VALVES

For Control Of
**WATER • OIL • STEAM
AIR • GAS • CRYOGENICS
SOLVENTS • OXYGEN
CORROSIVE FLUIDS**





WELCOME TO MAGNATROL

Process Control Solenoid Valves For

Water • Oil • Air • Gas • Steam • Cryogenics • Vacuum • Solvents • Brine • Oxygen • Corrosive Fluids



Magnatrol Valve Corp.

- Established 1936
- Experienced Dedicated Sales Staff
- Application / Engineering Assistance
- Excellent Product Support
- Quick Delivery

Our continued success has come from manufacturing a top quality product, product support, commitment to service and on-time delivery assuring complete customer satisfaction.

Our Products

Every valve is manufactured and tested in-house following Quality Assurance Standards where production operations are under the control of our dedicated, experienced staff and workforce.

- High Quality Bronze and Stainless Steel Solenoid Valves*
- Pressures up to 500 PSI *
- Temperatures up to 400° F *
- Cryogenic and Oxygen Service Applications
- Normally Closed (Energize to Open)
- Normally Open (Energize to Close)
- Continuous Duty Coils for all AC & DC Voltages
- NO Differential Pressure Required to Open
- Full Port-Internal Pilot Operated or Direct Acting
- 2-Way Straight Thru Design
- Packless Construction

* **Custom Engineered Valves**, Special Alloys, Temperatures, Pressures and Applications as well as Modifications to Standard Magnatrol Valves are available through Magnatrol's **Clark-Cooper Division**. (See bottom of page 3)

| TABLE OF CONTENTS | |
|--------------------------------------|----------|
| Category | Pages(s) |
| Coils..... | 4 |
| Construction Features..... | 5 |
| Bronze Valves | |
| N & NR..... | 6 & 7 |
| A & AR..... | 8 & 9 |
| M & MR..... | 10 & 11 |
| S & SR..... | 12 & 13 |
| L & LR..... | 14 & 15 |
| G & GR..... | 16 & 17 |
| D..... | 18 |
| Strainers..... | 19 |
| Stainless Steel Valves | |
| K & KR..... | 20 & 21 |
| W & WR..... | 22 & 23 |
| Optional Features..... | 24 & 25 |
| Ordering Information..... | 26 & 27 |
| Terms & Conditions/Contact Info..... | 28 |

| ADDITIONAL CATALOGS | |
|--|---|
| Technical/Engineering Catalog .. 3006-ENG | Technical & Engineering Data including: |
| | • Sandy Well Water Valves |
| | • Gritty Coolant Valves |
| Universal Mount Catalog .. 3006-UM | Valves can be mounted in any position |

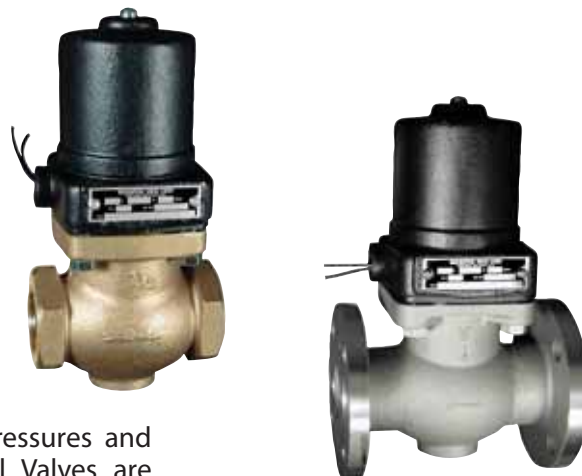

MAGNATROL VALVE CORPORATION

Magnatrol Valve Corporation • P.O. Box 17 • 67 Fifth Avenue • Hawthorne • New Jersey • 07507
 info@magnatrol.com • Phone: 973-427-4341 • Fax: 973-427-7611 • www.magnatrol.com



VALVE SELECTION CHART

**Ordering Information - See Pages 26 & 27
For Optional Features - See Pages 24 & 25**

VALVE SELECTION CHART

(For Fluids/Gases Not Listed And For Special Applications, Consult Factory)

| Max . Temperature | Up To 212°F | | | | Up To 400°F | | | | | |
|---------------------|-------------|---------|-----------|---------|-------------|---------|---------|-----------------|---------|--|
| Construction | Bronze | | | | | | | Stainless Steel | | |
| Valve Type | D | G/GR | N/NR | A/AR | M/MR | S/SR | L/LR | K/KR | W/WR | |
| Page | 18 | 16 & 17 | 6 & 7 | 8 & 9 | 10 & 11 | 12 & 13 | 14 & 15 | 20 & 21 | 22 & 23 | |
| Max. Diff. Pressure | 30 PSI | 50 PSI | 300 PSI | 500 PSI | 150 PSI | 180 PSI | 500 PSI | 500 PSI | 180 PSI | |
| Pipe Size Inches | 3/8"-2" | 1"-3" | 3/8"-3/4" | 1/2"-3" | 3/8"-3/4" | 1/2"-3" | 1/2"-3" | 1/2"-3" | 1/2"-3" | |
| Internal Port Size | Full | Full | Reduced | Full | Reduced | Full | Full | Full | Full | |
| Air | ◆ | ◆ | ◆ | ◆ | ◆ | | ◆ | ◆ | | |
| Brine | | | ◆ | ◆ | ◆ | | ◆ | ◆ | | |
| Gas | ◆ | ◆ | | ◆ | ◆ | | ◆ | ◆ | | |
| Oil | ◆ | | ◆ | ◆ | ◆ | | ◆ | ◆ | | |
| Solvents | ◆ | ◆ | ◆ | ◆ | ◆ | | ◆ | ◆ | | |
| Water | ◆ | ◆ | ◆ | ◆ | ◆ | | ◆ | ◆ | | |
| Vacuum | ◆ | ◆ | ◆ | ◆ | | | | | | |
| Steam | | | | | ◆ | ◆ | | | ◆ | |
| Cryogenic | | | | | ◆ | | ◆ | ◆ | | |
| Oxygen, Liquid | | | | | ◆ | | ◆ | ◆ | | |
| Oxygen, Gaseous | ◆ | ◆ | | ◆ | | | ◆ | ◆ | | |
| Corrosive | | | | | | | | ◆ | | |

Use the chart above to determine suitable types of Magnatrol valves for a given application.

Example: A normally closed 1/2" valve for use on 100 psi steam, there are three types suitable and the final selection can only be made after referring to Bulletins 3006-M, 3006-S and 3006-W on pages 10, 12 and 22 respectively.

Maximum Differential Pressure:

When specifying a valve, the Maximum Differential Pressure must be equal to or greater than the application. Care should be taken not to "over specify" the valve by choosing a valve with a Maximum Differential Pressure that is excessively beyond the application.

If you are unsure please consult the factory.

**For Custom Engineered Valves,
modifications to standard Magnatrol valves and valves that fall outside standard valve capabilities,
contact Magnatrol's Clark Cooper Division**

2-Way and 3-Way • 1/4" Thru 6"

- Pressures to 10,000
- Fluid Temperatures up to 550°F
- Dirty / Viscous & Corrosive Fluids
- Bronze, 316SS, Monel, Alloy 20 & Hastelloy
- End connections: NPT, Flange, Union, Socket Weld, Butt Weld, Pipe Nipples etc.
- Options: Remote Trip with Manual or Automatic Reset and many others
- Designs for Navy and Marine Service

3-Valve
Manifold for
CNG Refueling



High Pressure
Cartridge Valve
10,000 PSI



3-Way Trip Valve with 2 Position
Indicating Switches
and Manual Reset



CLARK - COOPER DIV.
855 INDUSTRIAL HIGHWAY - #4
CINNAMINSON, NJ 08077

Phone: 856 - 829 - 4580 • Fax: 856 - 829 - 7303
Email: techsupport@clarkcooper.com
Web: www.clarkcooper.com

MAGNATROL VALVE CORPORATION



SOLENOID COILS CONTINUOUS DUTY COILS

ELECTRICAL CHARACTERISTICS

Coils are stocked for the following voltages:

| Voltage | 6 | 12 | 24 | 32 | 48 | 64 | 75 | 120 | 208 | 240 | 480 | 575 |
|----------------|---|----|----|----|----|----|----|-----|-----|-----|-----|-----|
| 50,60 Hertz AC | | | • | | | | | • | • | • | • | • |
| DC | • | • | • | • | • | • | • | * | | * | | |



ENCAPSULATED COIL

75V DC for locomotive applications * Furnished with surge protecting capacitor

Reference should be made to the Bulletins to determine the availability of a required valve for a specific power supply.

Consult the factory for information regarding voltage and frequencies not listed.

Valves for A.C. service can be converted for use on other A.C. voltages simply by changing the coil. Similarly D.C. valves can be converted for other D.C. voltages. Consult factory regarding conversion from A.C. to D.C. or D.C. to A.C.

CURRENT CONSUMPTION:

Current values shown in the bulletins are for 120 volts, 60 hertz. For other voltages the current is inversely proportional: For instance, if a given valve draws 0.5 amperes on 120 volts it would draw 0.25 amperes on 240 volts, or 0.125 amperes on 480 volts. Where power consumption is shown in D.C. watts, the values given should be divided by line voltage to obtain the current in amperes. Power consumption for all valves is shown in the individual bulletins.

CONSTRUCTION:

Continuous Duty Construction: Coils can be energized continuously without overheating or failure.

Wire Leads: 18" long 18 gauge wire standard (longer continuous leads available)

Encapsulated: Coils are encapsulated for temperature of intended service, providing excellent resistance to shock, moisture, oil and chemicals

COIL CLASS:

| GENERAL SERVICE - CLASS "B" | | HIGH TEMPERATURE - CLASS "H" | |
|-----------------------------|-----------------------------|------------------------------|-----------------------------|
| Maximum Fluid Temperature | Maximum Ambient Temperature | Maximum Fluid Temperature | Maximum Ambient Temperature |
| 212° F (413° C) | 104° F (40° C) | 400° F (206° C) | 212° F (100° C) |

INSTALLATION:

The coil is a two wire device which may be controlled by either a single or double pole switch. The switch should always be installed in the hot leg of 120 volt circuits. Where both legs are hot, such as 240 or 480 volt circuits, a double pole switch is preferable, however, if a single pole switch is used, then the wiring should have top quality insulation since even minute leakage currents may give rise to sticking problems. On motor hookup with step control starter, full voltage should be supplied to coil immediately.

Note: Coil can be readily changed while valve is still under pressure.

VALVE CONSTRUCTION FEATURES



Valve Construction Features:

- 2-way straight thru globe design
- Bronze or Stainless Steel body w/ female NPT threads standard
- Stainless Steel available with 150# and 300# flanged ends
- Full port-internal pilot operated or direct acting
- Packless construction
- Continuous duty coils for all voltages
- No differential pressure required to open

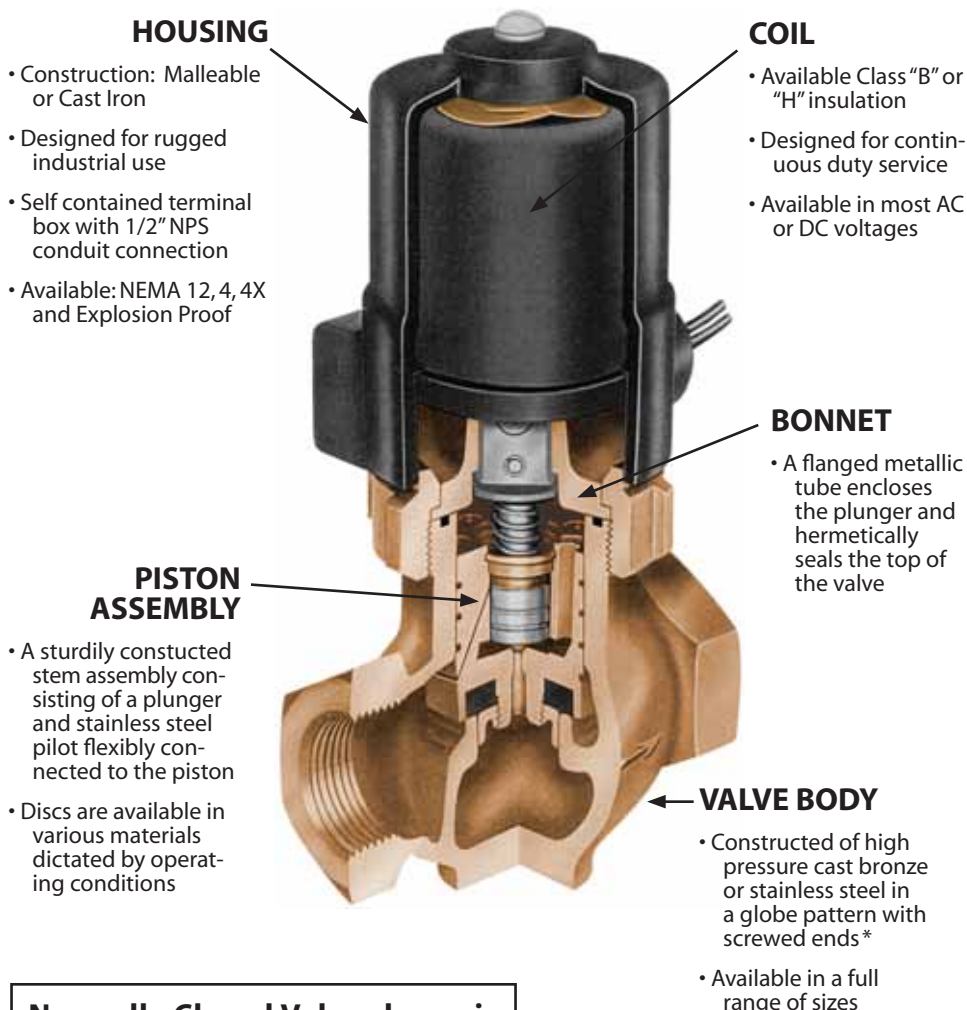

Normally Closed Valve shown is typical of Type A, 1/2" thru 1-1/4"

* Stainless Steel valves available with flanged ends. Flanged Bronze valves available through Magnatrol's **Clark-Cooper Division** (See bottom of page 3).

Easy In-Line Service

Inspect, clean or service all internal parts of full port-internal pilot operated or direct acting solenoid valves while the valve body remains in the pipeline shortening costly down time and increasing productivity.

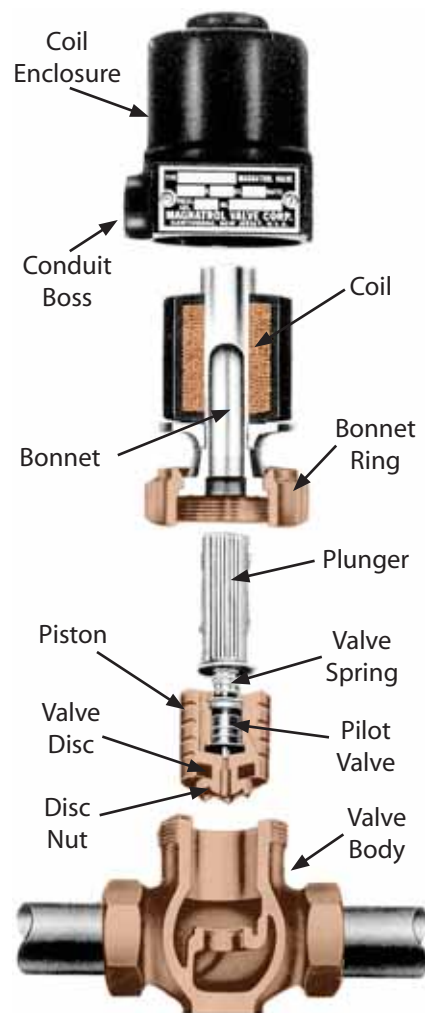

MAGNATROL SOLENOID OPERATED VALVES are used to control the flow of liquids or gases, generally in conjunction with automatic control apparatus such as thermostat, float switch, time switch, or flow meter.



BRONZE SOLENOID VALVES

Dependable • Packless

TYPE "N" - NORMALLY CLOSED 3/8" TO 3/4" PIPE SIZE

NO DIFFERENTIAL PRESSURE REQUIRED TO OPEN

DIRECT ACTING - ORIFICE SIZES 3/32" TO 1/2"

OPERATION:

Valve opens when energized and closes when de-energized. In this direct acting valve, when the coil is energized, the stem is lifted from its conical seat by the plunger.

CONSTRUCTION: (* Wetted parts)

- *Valve Body - Cast Bronze, Globe Pattern - NPT ends
- Coil Enclosure - Malleable Iron, 1/2" NPS conduit conn.
- *Plunger - 430 Stainless Steel
- *Valve Stem - 303 Stainless Steel
- *Bonnet Tube - 304 Stainless Steel
- *Spring - 302 Stainless Steel
- *Body Seal - Buna N
- *Orifice Seal - Metal to Metal
- *AC Shading Coil - Copper
- *Stem Pin - Inconel
- Coil - Encapsulated Class B, 18" leads - (Class H available)

APPLICATION:

To control the flow of **Water, Oil, Air, Gas, Solvents, Brine, Vacuum** and any other fluids not reactive with construction materials and free of sediment. Valve operates from zero to maximum differential pressure indicated in table. Valve must be mounted in horizontal pipe with solenoid enclosure vertical and on top.

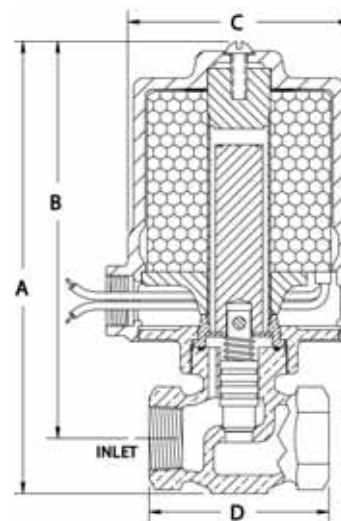

MAX. FLUID TEMP.
212° F
MAX. STATIC PRESSURE
300 PSI



**FOR OPTIONS & ACCESSORIES
SEE PAGES 24 & 25**

| Pipe Size Inches | Max. Diff. PSI | Valve Port Size | Type No. | Watts AC | Amps Hold 120-60 | Amps Inrush 120-60 | Watts DC | Ship Wt. Lbs. | Dimensions In Inches | | | | |
|------------------|----------------|-----------------|----------|----------|------------------|--------------------|----------|---------------|----------------------|-------|-------|-------|-------|
| | | | | | | | | | A | B | C | D | |
| 3/8 | 25 | 3/8 | 18N21 | 25 | 0.4 | 1.1 | 18 | 6 | 6-1/8 | 5-3/8 | 2-3/4 | 2-1/2 | |
| | 50 | 1/4 | 18N41 | | | | | | | | | | |
| | 75 | 3/16 | 18N51 | | | | | | | | | | |
| | 100 | 5/32 | 18N81 | | | | | | | | | | |
| | 150 | 1/8 | 18N61 | | | | | | | | | | |
| | 225 | 3/32 | 18N71 | | | | | | | | | | |
| 3/8 | 50 | 3/8 | 33N21 | 45 | 0.8 | 2.3 | 23 | 10 | 7 | 6-1/4 | 3-1/2 | 2-1/2 | |
| | 75 | 5/16 | 33N31 | | | | | | | | | | |
| | 100 | 1/4 | 33N41 | | | | | | | | | | |
| | 150 | 3/16 | 33N51 | | | | | | | | | | |
| | 300 | 1/8 | 33N61 | | | | | | | | | | |
| | 1/2 | 25 | 3/8 | | | | | | | | | | 18N22 |
| 50 | | 1/4 | 18N42 | | | | | | | | | | |
| 75 | | 3/16 | 18N52 | | | | | | | | | | |
| 100 | | 5/32 | 18N82 | | | | | | | | | | |
| 150 | | 1/8 | 18N62 | | | | | | | | | | |
| 225 | | 3/32 | 18N72 | | | | | | | | | | |
| 1/2 | | 50 | 3/8 | 33N22 | 45 | 0.8 | 2.4 | 23 | 10 | 7-1/8 | 6-3/8 | 3-1/2 | 2-3/4 |
| | | 75 | 5/16 | 33N32 | | | | | | | | | |
| | | 100 | 1/4 | 33N42 | | | | | | | | | |
| | | 150 | 3/16 | 33N52 | | | | | | | | | |
| | | 300 | 1/8 | 33N62 | | | | | | | | | |
| | | 3/4 | 15 | 1/2 | | | | | | | | | |
| 35 | 5/16 | | 18N33 | | | | | | | | | | |
| 30 | 1/2 | | 33N13 | 45 | 0.8 | 2.5 | 23 | 10 | 7-3/8 | 6-1/2 | 3-1/2 | 2-7/8 | |
| 75 | 5/16 | | 33N33 | | | | | | | | | | |

Strainers are recommended for use with solenoid valves (See page 19)

When you order please supply the following:

- Pipe Size
 - Valve Type
 - Voltage (AC or DC)
 - Hertz
 - Fluid
 - Fluid Temperature
 - Max. Diff. Pressure
 - Optional Features
- (See pages 24 & 25)

BRONZE SOLENOID VALVES

Dependable • Packless



TYPE "NR" - NORMALLY OPEN

3/8" TO 3/4" PIPE SIZE

NO DIFFERENTIAL PRESSURE REQUIRED TO OPEN

DIRECT ACTING - ORIFICE SIZES 3/32" TO 1/2"

OPERATION:

Valve closes when energized and opens when de-energized. In this direct acting valve, when the coil is energized, the stem is pressed into its conical seat by the plunger.

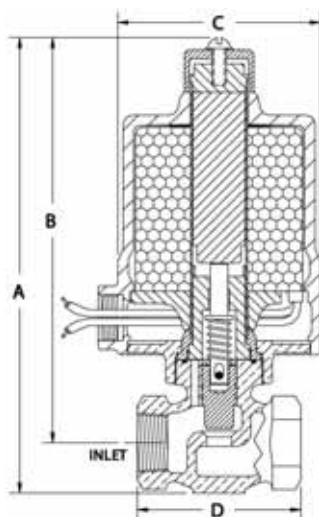

CONSTRUCTION: (* Wetted parts)

- *Valve Body - Cast Bronze, Globe Pattern - NPT ends
- Coil Enclosure - Malleable Iron, 1/2" NPS conduit conn.
- *Plunger - 430 Stainless Steel
- *Poppet - 304 Stainless Steel
- *Stem - 303 Stainless Steel
- *Bonnet Tube - 304 Stainless Steel
- *Spring - Inconel
- *Body Seal - Buna N
- *Orifice Seal - Metal to Metal
- *AC Shading Coil - Copper
- *Stem Pin - 304 Stainless Steel
- Coil - Encapsulated Class B, 18" leads - (Class H available)

APPLICATION:

To control the flow of Water, Oil, Air, Gas, Solvents, Brine, Vacuum and any other fluids not reactive with construction materials and free of sediment. Valve operates from zero to maximum differential pressure indicated in table. Valve must be mounted in horizontal pipe with solenoid enclosure vertical and on top.



**FOR OPTIONS & ACCESSORIES
SEE PAGES 24 & 25**

MAX. FLUID TEMP.

212° F

MAX. STATIC PRESSURE

300 PSI

Strainers are recommended for use with solenoid valves
(See page 19)

When you order please supply the following:

- Pipe Size
- Valve Type
- Voltage (AC or DC)
- Hertz
- Fluid
- Fluid Temperature
- Max. Diff. Pressure
- Optional Features

(See pages 24 & 25)

| Pipe Size Inches | Max. Diff. PSI | Valve Port Size | Type No. | Watts AC | Amps Hold 120-60 | Amps Inrush 120-60 | Watts DC | Ship Wt. Lbs. | Dimensions In Inches | | | |
|------------------|----------------|-----------------|----------|----------|------------------|--------------------|----------|---------------|----------------------|-------|-------|-------|
| | | | | | | | | | A | B | C | D |
| 3/8 | 23 | 3/8 | 18NR21 | 25 | 0.5 | 1.4 | 18 | 7 | 6-7/8 | 6-1/8 | 2-3/4 | 2-1/2 |
| | 45 | 1/4 | 18NR41 | | | | | | | | | |
| | 70 | 3/16 | 18NR51 | | | | | | | | | |
| | 90 | 5/32 | 18NR81 | | | | | | | | | |
| | 135 | 1/8 | 18NR61 | | | | | | | | | |
| | 200 | 3/32 | 18NR71 | | | | | | | | | |
| 1/2 | 45 | 3/8 | 33NR21 | 45 | 1.0 | 2.6 | 23 | 10 | 7-3/4 | 7 | 3-1/2 | 2-1/2 |
| | 70 | 5/16 | 33NR31 | | | | | | | | | |
| | 90 | 1/4 | 33NR41 | | | | | | | | | |
| | 135 | 3/16 | 33NR51 | | | | | | | | | |
| | 270 | 1/8 | 33NR61 | | | | | | | | | |
| | 3/4 | 23 | 3/8 | | | | | | | | | |
| 45 | | 1/4 | 18NR42 | | | | | | | | | |
| 70 | | 3/16 | 18NR52 | | | | | | | | | |
| 90 | | 5/32 | 18NR82 | | | | | | | | | |
| 135 | | 1/8 | 18NR62 | | | | | | | | | |
| 200 | | 3/32 | 18NR72 | | | | | | | | | |
| 3/4 | 45 | 3/8 | 33NR22 | 45 | 1.0 | 2.7 | 23 | 10 | 7-7/8 | 7-1/8 | 3-1/2 | 2-3/4 |
| | 70 | 5/16 | 33NR32 | | | | | | | | | |
| | 90 | 1/4 | 33NR42 | | | | | | | | | |
| | 135 | 3/16 | 33NR52 | | | | | | | | | |
| | 270 | 1/8 | 33NR62 | | | | | | | | | |
| | 3/4 | 13 | 1/2 | | | | | | | | | |
| 32 | | 5/16 | 18NR33 | | | | | | | | | |
| 27 | | 1/2 | 33NR13 | 45 | 1.0 | 2.8 | 23 | 10 | 8-1/8 | 7-1/4 | 3-1/2 | 2-7/8 |
| 70 | 5/16 | 33NR33 | | | | | | | | | | |



BRONZE SOLENOID VALVES

Dependable • Packless

TYPE "A" FULL PORT - NORMALLY CLOSED

1/2" TO 3" PIPE SIZE

NO DIFFERENTIAL PRESSURE REQUIRED TO OPEN

MAX. FLUID TEMP.

212° F

MAX. STATIC PRESSURE

300 PSI

Except valves listed for 500 PSI

OPERATION:

Valve opens when energized and closes when de-energized. When the coil is energized the pilot valve opens, relieving the pressure above the piston, which is then lifted from its seat by the plunger. Upon de-energizing the coil, a spring closes the pilot valve and opens a bleed passageway to permit pressure to build above the piston and seat it.

CONSTRUCTION: (* Wetted parts)

- *Valve Body - Cast Bronze, Globe Pattern - NPT ends
- *Piston - Bronze
- *Coil Enclosure - Malleable or Cast Iron, 1/2" NPS conduit conn.
- *Plunger - 430 Stainless Steel
- *Pilot Valve - 303 Stainless Steel
- *Bonnet Tube - 304 Stainless Steel
- *Spring - 302 Stainless Steel
- *Body Seal - Buna N or Non Asbestos Gasket
- *Orifice Seal - Buna N (Viton or Glass Filled Teflon available)
- *AC Shading Coil - Copper
- *Stem Pin - Inconel
- Coil - Encapsulated Class B, 18" leads - (Class H available)

APPLICATION:

To control the flow of **Water, Oil, Air, Gas, Solvents, Brine, Vacuum** and any other fluids not reactive with construction materials and free of sediment. Valve operates from zero to maximum differential pressure indicated in table. Valve must be mounted in horizontal pipe with solenoid enclosure vertical and on top.

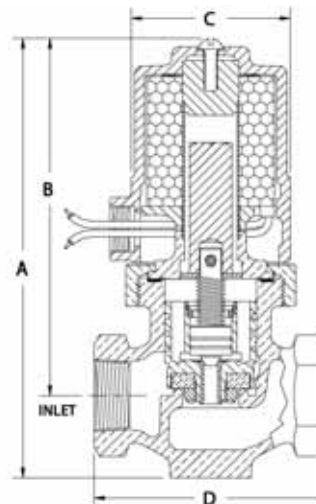

| Pipe Size Inches | Max. Diff. PSI | Type No. | Watts AC | Amps Hold 120-60 | Amps Inrush 120-60 | Watts DC | Ship Wt. Lbs. | Dimensions In Inches | | | |
|------------------|----------------|----------|----------|------------------|--------------------|----------|---------------|----------------------|--------|-------|-------|
| | | | | | | | | A | B | C | D |
| 1/2 | 110 | 18A42 | 25 | 0.4 | 1.2 | 18 | 8 | 7 | 5-7/8 | 2-3/4 | 3-1/4 |
| | 200 | 18A32 | | | | | | | | | |
| | 300 | 18A52 | | | | | | | | | |
| 3/4 | 500 | E33A62 | 45 | 0.8 | 2.4 | 23 | 16 | 8 | 6-7/8 | 4-1/8 | 3-1/4 |
| | 50 | 18A23 | 25 | 0.4 | 1.3 | 18 | 8 | 7-1/8 | 6 | 2-3/4 | 3-1/2 |
| | 110 | 18A43 | | | | | | | | | |
| | 160 | 118A43 | 40 | 0.6 | 2.0 | 28 | 12 | 8-1/8 | 7 | 3-1/2 | 3-1/2 |
| | 200 | 33A33 | 45 | 0.8 | 2.6 | 23 | 17 | 8-1/8 | 7 | 4-1/8 | 3-1/2 |
| | 300 | 33A53 | | | | | | | | | |
| 500 | E133A63 | 65 | 1.2 | 3.9 | 33 | 19 | 8-7/8 | 7-1/2 | 4-1/8 | 4-1/8 | |
| 1 | 50 | 18A24 | 25 | 0.4 | 1.5 | 18 | 10 | 7-7/8 | 6-5/8 | 2-3/4 | 4-1/8 |
| | 110 | 18A44 | | | | | | | | | |
| | 160 | 118A44 | 40 | 0.6 | 2.3 | 28 | 14 | 8-7/8 | 7-1/2 | 3-1/2 | 4-1/8 |
| | 200 | 33A34 | 45 | 0.8 | 2.8 | 23 | 19 | 8-7/8 | 7-1/2 | 4-1/8 | 4-1/8 |
| | 300 | 33A54 | | | | | | | | | |
| 500 | E133A64 | 65 | 1.2 | 4.2 | 33 | 20 | 10-3/8 | 8-3/4 | 4-1/2 | 4-1/2 | |
| 1-1/4 | 50 | 18A25 | 25 | 0.4 | 1.6 | 18 | 12 | 8-3/8 | 6-3/4 | 2-3/4 | 4-1/2 |
| | 90 | 18A45 | | | | | | | | | |
| | 150 | 118A45 | 40 | 0.6 | 2.4 | 28 | 16 | 9-3/8 | 7-3/4 | 3-1/2 | 4-1/2 |
| | 200 | 33A35 | 45 | 0.8 | 3.0 | 23 | 20 | 10 | 8-1/8 | 4 | 4-7/8 |
| | 300 | 33A55 | | | | | | | | | |
| 500 | †† 40A65 | 60 | 1.2 | 6.2 | N/A | 20 | 10-3/8 | 8-3/4 | 4-1/2 | 4-1/2 | |
| 1-1/2 | 50 | 35A26 | 45 | 0.8 | 3.2 | 23 | 20 | 10 | 8-1/8 | 4 | 4-7/8 |
| | 115 | 35A46 | | | | | | | | | |
| | 160 | 135A46 | 65 | 1.2 | 4.8 | 33 | 24 | 11 | 9-1/8 | 4-1/2 | 4-7/8 |
| | 200 | 41A36 | 60 | 1.2 | 6.7 | 35 | 31 | 11 | 8-3/4 | 5-3/8 | 6 |
| | 300 | 41A56 | | | | | | | | | |
| 500 | 141A66 | 85 | 2.0 | 10.0 | 45 | 36 | 12 | 9-3/4 | 5-3/8 | 6 | |
| 2 | 50 | 36A27 | 45 | 0.8 | 3.5 | 23 | 31 | 11 | 8-3/4 | 5-3/8 | 6 |
| | 100 | 36A47 | | | | | | | | | |
| | 150 | 136A47 | 65 | 1.2 | 5.0 | 33 | 43 | 12-7/8 | 10-1/8 | 5-7/8 | 7-1/4 |
| | 200 | 42A37 | 60 | 1.2 | 7.4 | 35 | 56 | 13-3/4 | 10-1/2 | 6-5/8 | 8-3/8 |
| | 300 | 42A57 | | | | | | | | | |
| 500 | 142A67 | 85 | 2.0 | 11.0 | 45 | 56 | 13-3/4 | 10-1/2 | 6-5/8 | 8-3/8 | |
| 2-1/2 | 50 | 43A28 | 60 | 1.2 | 8.0 | 35 | 43 | 12-7/8 | 10-1/8 | 5-7/8 | 7-1/4 |
| | 125 | 43A48 | | | | | | | | | |
| | 200 | 43A38 | | | | | | | | | |
| | 300 | 143A58 | | | | | | | | | |
| 3 | 50 | 44A29 | 60 | 1.2 | 8.8 | 35 | 56 | 13-3/4 | 10-1/2 | 6-5/8 | 8-3/8 |
| | 100 | 44A49 | | | | | | | | | |
| | 200 | 44A39 | | | | | | | | | |
| | 300 | 144A59 | | | | | | | | | |

FOR OPTIONS & ACCESSORIES SEE PAGES 24 & 25

Strainers are recommended for use with solenoid valves (See page 19)

When you order please supply the following:

- Pipe Size
 - Valve Type
 - Voltage (AC or DC)
 - Hertz
 - Fluid
 - Fluid Temperature
 - Max. Diff. Pressure
 - Optional Features
- (See pages 24 & 25)

†† Not available for DC operation

BRONZE SOLENOID VALVES

Dependable • Packless



TYPE "AR" FULL PORT - NORMALLY OPEN 1/2" TO 3" PIPE SIZE

NO DIFFERENTIAL PRESSURE REQUIRED TO OPEN

OPERATION:

Valve closes when energized and opens when de-energized. When the coil is energized the plunger presses the poppet, closing the pilot orifice, and opens a bleed passageway to permit pressure to build above the piston and seat it. Upon de-energizing the coil, the pilot orifice is opened, relieving the pressure above the piston allowing it to leave its seat. The bottom spring allows the valve to operate at zero pressure drop.

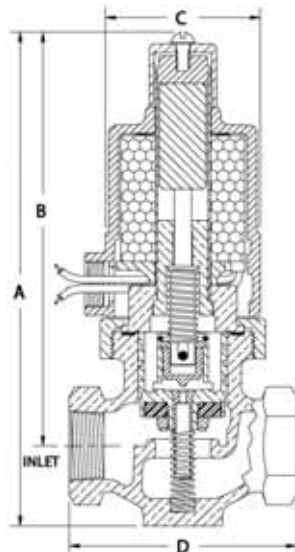

CONSTRUCTION: (* Wetted parts)

- *Valve Body - Cast Bronze, Globe Pattern - NPT ends
- *Piston - Bronze
- Coil Enclosure - Malleable or Cast Iron, 1/2" NPS conduit conn.
- *Plunger - 430 Stainless Steel
- *Pilot Valve - 303 Stainless Steel
- *Bonnet Tube - 304 Stainless Steel
- *Spring - 302 Stainless Steel
- *Body Seal - Buna N or Non Asbestos Gasket
- *Orifice Seal - Buna N (Viton or Glass Filled Teflon available)
- *AC Shading Coil - Copper
- *Stem Pin - Inconel
- Coil - Encapsulated Class B, 18" leads - (Class H available)

APPLICATION:

To control the flow of **Water, Oil, Air, Gas, Solvents, Brine, Vacuum** and any other fluids not reactive with construction materials and free of sediment. Valve operates from zero to maximum differential pressure indicated in table. Valve must be mounted in horizontal pipe with solenoid enclosure vertical and on top.



MAX. FLUID TEMP.
212° F

MAX. STATIC PRESSURE
300 PSI

Except valves listed for 500 PSI

**FOR OPTIONS & ACCESSORIES
SEE PAGES 24 & 25**

Strainers are recommended for use with solenoid valves (See page 19)

When you order please supply the following:

- Pipe Size
- Valve Type
- Voltage (AC or DC)
- Hertz
- Fluid
- Fluid Temperature
- Max. Diff. Pressure
- Optional Features

(See pages 24 & 25)

†† Not available for DC operation

| Pipe Size Inches | Max. Diff. PSI | Type No. | Watts AC | Amps Hold 120-60 | Amps Inrush 120-60 | Watts DC | Ship Wt. Lbs. | Dimensions In Inches | | | |
|------------------|----------------|-----------|----------|------------------|--------------------|----------|---------------|----------------------|--------|-------|-------|
| | | | | | | | | A | B | C | D |
| 1/2 | 110 | 18AR42 | 25 | 0.5 | 1.5 | 18 | 8 | 8-1/8 | 7 | 2-3/4 | 3-1/4 |
| | 200 | 18AR32 | | | | | | | | | |
| | 300 | 18AR52 | | | | | | | | | |
| | 500 | E33AR62 | | | | | | | | | |
| 3/4 | 50 | 18AR23 | 45 | 1.0 | 2.7 | 23 | 16 | 9-3/8 | 8-1/4 | 4-1/8 | 3-1/4 |
| | 110 | 18AR43 | | | | | | | | | |
| | 200 | 33AR33 | | | | | | | | | |
| | 300 | 33AR53 | | | | | | | | | |
| | 500 | E133AR63 | | | | | | | | | |
| 1 | 50 | 18AR24 | 25 | 0.5 | 1.8 | 18 | 11 | 9 | 7-3/4 | 2-3/4 | 4-1/8 |
| | 110 | 18AR44 | | | | | | | | | |
| | 200 | 33AR34 | | | | | | | | | |
| | 300 | 33AR54 | | | | | | | | | |
| | 500 | E133AR64 | | | | | | | | | |
| 1-1/4 | 50 | 18AR25 | 25 | 0.5 | 1.9 | 18 | 13 | 9-3/4 | 8-1/8 | 2-3/4 | 4-1/2 |
| | 90 | 18AR45 | | | | | | | | | |
| | 200 | 33AR35 | | | | | | | | | |
| | 300 | 33AR55 | | | | | | | | | |
| | 500 | †† 40AR65 | | | | | | | | | |
| 1-1/2 | 50 | 35AR26 | 45 | 1.0 | 3.8 | 23 | 21 | 11-3/8 | 9-1/2 | 4 | 4-7/8 |
| | 115 | 35AR46 | | | | | | | | | |
| | 200 | 41AR36 | | | | | | | | | |
| | 300 | 41AR56 | | | | | | | | | |
| | 500 | 141AR66 | | | | | | | | | |
| 2 | 50 | 36AR27 | 45 | 1.0 | 4.2 | 23 | 31 | 12-3/8 | 10-1/8 | 5-3/8 | 6 |
| | 100 | 36AR47 | | | | | | | | | |
| | 200 | 42AR37 | | | | | | | | | |
| | 300 | 42AR57 | | | | | | | | | |
| | 500 | 142AR67 | | | | | | | | | |
| 2-1/2 | 50 | 43AR28 | 60 | 1.7 | 8.0 | 35 | 45 | 13-1/2 | 10-3/4 | 5-7/8 | 7-1/4 |
| | 125 | 43AR48 | | | | | | | | | |
| | 200 | 43AR38 | | | | | | | | | |
| | 300 | 143AR58 | | | | | | | | | |
| | 500 | 143AR58 | | | | | | | | | |
| 3 | 50 | 44AR29 | 60 | 1.7 | 8.8 | 35 | 57 | 14-3/8 | 11-1/8 | 6-5/8 | 8-3/8 |
| | 100 | 44AR49 | | | | | | | | | |
| | 200 | 44AR39 | | | | | | | | | |
| | 300 | 144AR59 | | | | | | | | | |
| | 500 | 144AR59 | | | | | | | | | |



BRONZE SOLENOID VALVES

Dependable • Packless

TYPE "M" - NORMALLY CLOSED 3/8" TO 3/4" PIPE SIZE

NO DIFFERENTIAL PRESSURE REQUIRED TO OPEN

DIRECT ACTING - ORIFICE SIZES 1/8" TO 1/2"

OPERATION:

Valve opens when energized and closes when de-energized. In this direct acting valve, when the coil is energized, the stem is lifted from its conical seat by the plunger.

CONSTRUCTION: (* Wetted parts)

- *Valve Body - Cast Bronze, Globe Pattern - NPT ends
- Coil Enclosure - Malleable Iron, 1/2" NPS conduit conn.
- *Plunger - 430 Stainless Steel
- *Valve Stem - 303 Stainless Steel
- *Bonnet Tube - 304 Stainless Steel
- *Spring - Inconel
- *Body Seal - Non Asbestos Gasket
- *Orifice Seal - Metal to Metal
- *AC Shading Coil - Copper
- *Stem Pin - Inconel
- Coil - Encapsulated Class H, 18" leads

APPLICATION:

To control the flow of **Steam, Hot Liquids, Hot Gases, Cryogenics**** and any other fluids not reactive with construction materials and free of sediment. Cryogenic fluids include Liquid Oxygen (-297°F), Liquid Argon (-303°F) and Liquid Nitrogen (-320°F). Valve operates from zero to maximum differential pressure indicated in table. Valve must be mounted in horizontal pipe with solenoid enclosure vertical and on top.

****Cleaning:**

- Cryogenic valves are degreased and cleaned to keep them free of moisture.
- Oxygen valves are also "black light" tested.

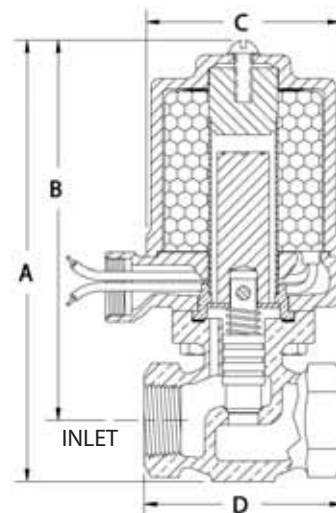

MAX. FLUID TEMP.
400° F
MAX. STATIC PRESSURE
150 PSI



**FOR OPTIONS & ACCESSORIES
SEE PAGES 24 & 25**

| Pipe Size Inches | Max. Diff. PSI | Valve Port Size | Type No. | Watts AC | Amps Hold 120-60 | Amps Inrush 120-60 | Watts DC | Ship Wt. Lbs. | Dimensions In Inches | | | | | | | | | | | | |
|------------------|----------------|-----------------|----------|----------|------------------|--------------------|----------|---------------|----------------------|-------|-------|-------|-----|-----|-----|-------|-------|-------|-------|-------|-------|
| | | | | | | | | | A | B | C | D | | | | | | | | | |
| 3/8 | 25 | 3/8 | 10M21 | 25 | 0.4 | 1.1 | 18 | 6 | 6-1/4 | 5-1/2 | 2-7/8 | 2-5/8 | | | | | | | | | |
| | 50 | 1/4 | 10M41 | | | | | | | | | | | | | | | | | | |
| | 75 | 3/16 | 10M51 | | | | | | | | | | | | | | | | | | |
| | 100 | 5/32 | 10M81 | | | | | | | | | | | | | | | | | | |
| | 150 | 1/8 | 10M61 | | | | | | | | | | | | | | | | | | |
| | 50 | 3/8 | 25M21 | | | | | | | | | | 45 | 0.8 | 2.3 | 23 | 10 | 7-1/8 | 6-3/8 | 3-1/2 | 2-5/8 |
| 75 | 5/16 | 25M31 | | | | | | | | | | | | | | | | | | | |
| 100 | 1/4 | 25M41 | | | | | | | | | | | | | | | | | | | |
| 150 | 3/16 | 25M51 | | | | | | | | | | | | | | | | | | | |
| 25 | 3/8 | 10M22 | 25 | 0.4 | 1.2 | 18 | 6 | 6-1/4 | 5-1/2 | 2-7/8 | 2-3/4 | | | | | | | | | | |
| 50 | 1/4 | 10M42 | | | | | | | | | | | | | | | | | | | |
| 75 | 3/16 | 10M52 | | | | | | | | | | | | | | | | | | | |
| 100 | 5/32 | 10M82 | | | | | | | | | | | | | | | | | | | |
| 150 | 1/8 | 10M62 | | | | | | | | | | | | | | | | | | | |
| 50 | 3/8 | 25M22 | | | | | | | | | | 45 | 0.8 | 2.4 | 23 | 10 | 7-1/8 | 6-3/8 | 3-1/2 | 2-3/4 | |
| 75 | 5/16 | 25M32 | | | | | | | | | | | | | | | | | | | |
| 100 | 1/4 | 25M42 | | | | | | | | | | | | | | | | | | | |
| 150 | 3/16 | 25M52 | | | | | | | | | | | | | | | | | | | |
| 3/4 | 15 | 1/2 | 10M13 | 25 | 0.4 | 1.3 | 18 | 7 | 6-1/2 | 5-5/8 | 2-7/8 | | | | | | | | | | 2-7/8 |
| | 35 | 5/16 | 10M33 | | | | | | | | | | | | | | | | | | |
| | 30 | 1/2 | 25M13 | | | | | | | | | 45 | 0.8 | 2.5 | 23 | 7-3/8 | 6-1/2 | 3-1/2 | 2-7/8 | | |
| | 75 | 5/16 | 25M33 | | | | | | | | | | | | | | | | | | |

Strainers are recommended for use with solenoid valves (See page 19)

When you order please supply the following:

- Pipe Size
 - Valve Type
 - Voltage (AC or DC)
 - Hertz
 - Fluid
 - Fluid Temperature
 - Max. Diff. Pressure
 - Optional Features
- (See pages 24 & 25)

BRONZE SOLENOID VALVES

Dependable • Packless



TYPE "MR" - NORMALLY OPEN

3/8" TO 3/4" PIPE SIZE

NO DIFFERENTIAL PRESSURE REQUIRED TO OPEN

DIRECT ACTING - ORIFICE SIZES 1/8" TO 1/2"

OPERATION:

Valve closes when energized and opens when de-energized. In this direct acting valve, when the coil is energized, the stem is pressed into its conical seat by the plunger.

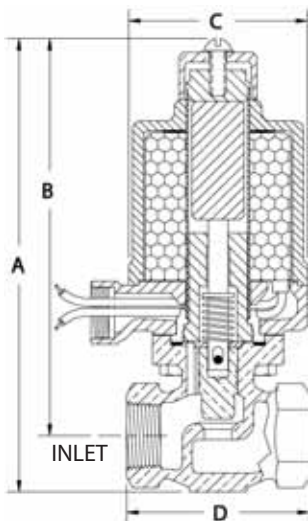

CONSTRUCTION: (* Wetted parts)

- *Valve Body - Cast Bronze, Globe Pattern - NPT ends
- Coil Enclosure - Malleable Iron, 1/2" NPS conduit conn.
- *Plunger - 430 Stainless Steel
- *Poppet - 304 Stainless Steel
- *Stem - 303 Stainless Steel
- *Bonnet Tube - 304 Stainless Steel
- *Spring - Inconel
- *Body Seal - Non Asbestos Gasket
- *Orifice Seal - Metal to Metal
- *AC Shading Coil - Copper
- *Stem Pin - Inconel
- Coil - Encapsulated Class H, 18" leads



APPLICATION:

To control the flow of Steam, Hot Liquids, Hot Gases, Cryogenics** and any other fluids not reactive with construction materials and free of sediment. Cryogenic fluids include Liquid Oxygen (-297°F), Liquid Argon (-303°F) and Liquid Nitrogen (-320°F). Valve operates from zero to maximum differential pressure indicated in table. Valve must be mounted in horizontal pipe with solenoid enclosure vertical and on top.

****Cleaning:**

- Cryogenic valves are degreased and cleaned to keep them free of moisture.
- Oxygen valves are also "black light" tested.

MAX. FLUID TEMP.
400° F
MAX. STATIC PRESSURE
150 PSI



**FOR OPTIONS & ACCESSORIES
SEE PAGES 24 & 25**

Strainers are recommended for use with solenoid valves (See page 19)

When you order please supply the following:

- Pipe Size
- Valve Type
- Voltage (AC or DC)
- Hertz
- Fluid
- Fluid Temperature
- Max. Diff. Pressure
- Optional Features

(See pages 24 & 25)

| Pipe Size Inches | Max. Diff. PSI | Valve Port Size | Type No. | Watts AC | Amps Hold 120-60 | Amps Inrush 120-60 | Watts DC | Ship Wt. Lbs. | Dimensions In Inches | | | |
|------------------|----------------|-----------------|----------|----------|------------------|--------------------|----------|---------------|----------------------|-------|-------|-------|
| | | | | | | | | | A | B | C | D |
| 3/8 | 23 | 3/8 | † 10MR21 | 25 | 0.5 | 1.4 | 18 | 7 | 7 | 6-1/4 | 2-7/8 | 2-5/8 |
| | 45 | 1/4 | † 10MR41 | | | | | | | | | |
| | 70 | 3/16 | † 10MR51 | | | | | | | | | |
| | 90 | 5/32 | † 10MR81 | | | | | | | | | |
| | 135 | 1/8 | † 10MR61 | | | | | | | | | |
| 1/2 | 45 | 3/8 | 25MR21 | 45 | 1.0 | 2.6 | 23 | 10 | 7-7/8 | 7-1/8 | 3-1/2 | 2-5/8 |
| | 70 | 5/16 | 25MR31 | | | | | | | | | |
| | 90 | 1/4 | 25MR41 | | | | | | | | | |
| | 135 | 3/16 | 25MR51 | | | | | | | | | |
| | 23 | 3/8 | 10MR22 | | | | | | | | | |
| 45 | 1/4 | 10MR42 | | | | | | | | | | |
| 70 | 3/16 | 10MR52 | | | | | | | | | | |
| 90 | 5/32 | 10MR82 | | | | | | | | | | |
| 135 | 1/8 | 10MR62 | | | | | | | | | | |
| 3/4 | 45 | 3/8 | 25MR22 | 45 | 1.0 | 2.7 | 23 | 10 | 7-7/8 | 7-1/8 | 3-1/2 | 2-3/4 |
| | 70 | 5/16 | 25MR32 | | | | | | | | | |
| | 90 | 1/4 | 25MR42 | | | | | | | | | |
| | 135 | 3/16 | 25MR52 | | | | | | | | | |
| | 13 | 1/2 | 10MR13 | | | | | | | | | |
| 32 | 5/16 | 10MR33 | | | | | | | | | | |
| 27 | 1/2 | 25MR13 | 45 | 1.0 | 2.8 | 23 | 11 | 8-1/8 | 7-1/4 | 3-1/2 | 2-7/8 | |
| 70 | 5/16 | 25MR33 | | | | | | | | | | |

† UL Listed Valves - Consult Factory

MAGNATROL VALVE CORPORATION



BRONZE SOLENOID VALVES

Dependable • Packless

TYPE "S" FULL PORT - NORMALLY CLOSED 1/2" TO 3" PIPE SIZE

NO DIFFERENTIAL PRESSURE REQUIRED TO OPEN

**MAX. FLUID TEMP.
400° F
MAX. STATIC PRESSURE
200 PSI**



**FOR OPTIONS & ACCESSORIES
SEE PAGES 24 & 25**

OPERATION:

Valve opens when energized and closes when de-energized. When the coil is energized the pilot valve opens, relieving the pressure above the piston, which is then lifted from its seat by the plunger. Upon de-energizing the coil, a spring closes the pilot valve and opens a bleed passageway to permit pressure to build above the piston and seat it.

CONSTRUCTION: (* Wetted parts)

- *Valve Body - Cast Bronze, Globe Pattern - NPT ends
- *Piston - Bronze
- Coil Enclosure - Malleable or Cast Iron, 1/2" NPS conduit conn.
- *Plunger - 430 Stainless Steel
- *Pilot Valve - 303 Stainless Steel
- *Bonnet Tube - 304 Stainless Steel
- *Spring - Inconel
- *Body Seal - Non Asbestos Gasket
- *Orifice Seal - Glass Filled Teflon
- *AC Shading Coil - Copper
- *Stem Pin - Inconel
- Coil - Encapsulated Class H, 18" leads

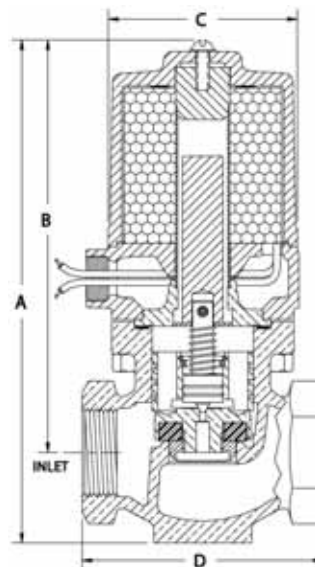

APPLICATION:

TO CONTROL THE FLOW OF STEAM. Steam must be free of sediment. Valve operates from zero to maximum differential pressure indicated in table. Valve must be mounted in horizontal pipe with solenoid enclosure vertical and on top.

| Pipe Size Inches | Max. Diff. PSI | Type No. | Watts AC | Amps Hold 120-60 | Amps Inrush 120-60 | Watts DC | Ship Wt. Lbs. | Dimensions In Inches | | | | | | | | |
|------------------|----------------|-----------|----------|------------------|--------------------|----------|---------------|----------------------|--------|-------|-------|----|--------|--------|-------|-------|
| | | | | | | | | A | B | C | D | | | | | |
| 1/2 | 90 | † 14S22 | 25 | 0.4 | 1.2 | 18 | 8 | 7 | 5-7/8 | 2-7/8 | 3-1/4 | | | | | |
| | 140 | † 114S42 | 40 | 0.6 | 1.8 | 28 | 11 | 8 | 6-7/8 | 3-1/2 | 3-1/4 | | | | | |
| | 180 | 129S42 | 65 | 1.2 | 3.6 | 33 | 11 | 8 | 6-7/8 | 3-1/2 | 3-1/4 | | | | | |
| 3/4 | 50 | † 14S23 | 25 | 0.4 | 1.3 | 18 | 9 | 7-1/8 | 6 | 2-7/8 | 3-1/2 | | | | | |
| | 110 | † 114S43 | 40 | 0.6 | 2.0 | 28 | 12 | 8-1/8 | 7 | 3-1/2 | 3-1/2 | | | | | |
| | 180 | 129S43 | 65 | 1.2 | 3.9 | 33 | 12 | 8-1/8 | 7 | 3-1/2 | 3-1/2 | | | | | |
| 1 | 25 | † 16S14 | 25 | 0.4 | 1.5 | 18 | 11 | 8 | 6-5/8 | 3-1/4 | 4-1/8 | | | | | |
| | 50 | † 116S24 | 40 | 0.6 | 2.3 | 28 | | | | | | | | | | |
| | 90 | † 116S44 | 40 | 0.6 | 2.3 | 28 | | | | | | | | | | |
| | 180 | 131S44 | 65 | 1.2 | 4.2 | 33 | | | | | | | | | | |
| 1-1/4 | 25 | † 17S15 | 25 | 0.4 | 1.6 | 18 | 12 | 8-3/8 | 6-3/4 | 3-1/2 | 4-1/2 | | | | | |
| | 50 | † 117S25 | 40 | 0.6 | 2.4 | 28 | | | | | | | | | | |
| | 140 | 132S45 | 65 | 1.2 | 4.5 | 33 | | | | | | | | | | |
| | 180 | †† 140S45 | 85 | 2.0 | 9.2 | N/A | | | | | | | | | | |
| 1-1/2 | 25 | 35S16 | 45 | 0.8 | 3.2 | 23 | 20 | 10 | 8-1/8 | 4 | 4-7/8 | | | | | |
| | 50 | 35S26 | 45 | 0.8 | 3.2 | 23 | | | | | | | | | | |
| | 90 | 135S46 | 65 | 1.2 | 4.8 | 33 | | | | | | | | | | |
| | 180 | 141S46 | 85 | 2.0 | 10.0 | 45 | | | | | | | | | | |
| 2 | 25 | 36S17 | 45 | 0.8 | 3.5 | 23 | 31 | 11 | 8-3/4 | 5-3/8 | 6 | | | | | |
| | 50 | 36S27 | 45 | 0.8 | 3.5 | 23 | | | | | | | | | | |
| | 115 | 42S47 | 60 | 1.2 | 7.4 | 35 | | | | | | | | | | |
| 2-1/2 | 180 | 142S47 | 85 | 2.0 | 11.0 | 45 | 36 | 12 | 9-3/4 | 5-3/8 | 6 | | | | | |
| | 25 | 43S18 | 60 | 1.2 | 8.0 | 35 | | | | | | 43 | 12-7/8 | 10-1/8 | 5-7/8 | 7-1/4 |
| | 50 | 43S28 | | | | | | | | | | | | | | |
| | 115 | 43S48 | | | | | | | | | | | | | | |
| 175 | 143S48 | 85 | | | | | 2.0 | 12.0 | 45 | | | | | | | |
| 3 | 25 | 44S19 | 60 | 1.2 | 8.8 | 35 | 56 | 13-3/4 | 10-1/2 | 6-5/8 | 8-3/8 | | | | | |
| | 50 | 44S29 | | | | | | | | | | | | | | |
| | 100 | 44S49 | | | | | | | | | | | | | | |
| | 150 | 144S49 | | | | | | | | | | 85 | 2.0 | 13.0 | 45 | |

Strainers are recommended for use with solenoid valves (See page 19)

When you order please supply the following:

- Pipe Size
 - Valve Type
 - Voltage (AC or DC)
 - Hertz
 - Fluid
 - Fluid Temperature
 - Max. Diff. Pressure
 - Optional Features
- (See pages 24 & 25)

† UL Listed Valves - Consult Factory †† Not available for DC operation

BRONZE SOLENOID VALVES

Dependable • Packless



TYPE "SR" FULL PORT - NORMALLY OPEN 1/2" TO 3" PIPE SIZE

NO DIFFERENTIAL PRESSURE REQUIRED TO OPEN

OPERATION:

Valve closes when energized and opens when de-energized. When the coil is energized the plunger presses the poppet, closing the pilot orifice, and opens a bleed passageway to permit pressure to build above the piston and seat it. Upon de-energizing the coil, the pilot orifice is opened, relieving the pressure above the piston allowing it to leave its seat. The bottom spring allows the valve to operate at zero pressure drop.

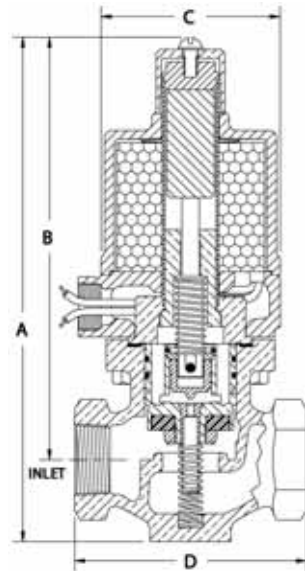

CONSTRUCTION: (* Wetted parts)

- *Valve Body - Cast Bronze, Globe Pattern - NPT ends
- *Piston - Bronze
- Coil Enclosure - Malleable or Cast Iron, 1/2" NPS conduit conn.
- *Plunger - 430 Stainless Steel
- *Poppet - 303 Stainless Steel
- *Stem - 303 Stainless Steel
- *Bonnet Tube - 304 Stainless Steel
- *Springs - Inconel and 302 Stainless Steel
- *Body Seal - Non Asbestos Gasket
- *Orifice Seal - Glass Filled Teflon
- *AC Shading Coil - Copper
- *Stem Pin - 304 Stainless Steel
- Coil - Encapsulated Class H, 18" leads



MAX. FLUID TEMP.

400° F

MAX. STATIC PRESSURE

200 PSI

APPLICATION:

TO CONTROL THE FLOW OF STEAM. Steam must be free of sediment. Valve operates from zero to maximum differential pressure indicated in table. Valve must be mounted in horizontal pipe with solenoid enclosure vertical and on top.

**FOR OPTIONS & ACCESSORIES
SEE PAGES 24 & 25**

Strainers are recommended for use with solenoid valves (See page 19)

When you order please supply the following:

- Pipe Size
- Valve Type
- Voltage (AC or DC)
- Hertz
- Fluid
- Fluid Temperature
- Max. Diff. Pressure
- Optional Features

(See pages 24 & 25)

| Pipe Size Inches | Max. Diff. PSI | Type No. | Watts AC | Amps Hold 120-60 | Amps Inrush 120-60 | Watts DC | Ship Wt. Lbs. | Dimensions In Inches | | | |
|------------------|----------------|------------|----------|------------------|--------------------|----------|---------------|----------------------|--------|-------|-------|
| | | | | | | | | A | B | C | D |
| 1/2 | 90 | † 14SR22 | 25 | 0.5 | 1.5 | 18 | 8 | 8-1/8 | 7 | 2-7/8 | 3-1/4 |
| | 140 | † 114SR42 | 40 | 0.8 | 2.4 | 28 | | | | | |
| | 180 | 129SR42 | 65 | 1.5 | 4.2 | 33 | 11 | 9-1/8 | 8 | 3-1/2 | 3-1/4 |
| 3/4 | 50 | † 14SR23 | 25 | 0.5 | 1.6 | 18 | 9 | 8-1/4 | 7-1/8 | 2-7/8 | 3-1/2 |
| | 110 | † 114SR43 | 40 | 0.8 | 2.6 | 28 | | | | | |
| | 180 | 129SR43 | 65 | 1.5 | 4.3 | 33 | 13 | 9-1/4 | 8-1/8 | 3-1/2 | 3-1/2 |
| 1 | 25 | † 16SR14 | 25 | 0.5 | 1.8 | 18 | | | | | |
| | 50 | † 116SR24 | 40 | 0.8 | 2.9 | 28 | 11 | 9-1/8 | 7-3/4 | 3-1/4 | 4-1/8 |
| | 90 | † 116SR44 | 40 | 0.8 | 2.9 | 28 | | | | | |
| | 180 | 131SR44 | 65 | 1.5 | 4.5 | 33 | 15 | 10 | 8-5/8 | 3-1/2 | 4-1/8 |
| 1-1/4 | 25 | † 17SR15 | 25 | 0.5 | 1.9 | 18 | | | | | |
| | 50 | † 117SR25 | 40 | 0.8 | 3.0 | 28 | 13 | 9-3/4 | 8-1/8 | 3-1/2 | 4-1/2 |
| | 140 | 132SR45 | 65 | 1.5 | 4.8 | 33 | 17 | 10-3/4 | 9-1/8 | 3-5/8 | 4-1/2 |
| | 180 | †† 140SR45 | 85 | 3.5 | 9.0 | N/A | 20 | 11 | 9-3/8 | 4-1/2 | 4-1/2 |
| 1-1/2 | 25 | 35SR16 | 45 | 1.0 | 3.8 | 23 | | | | | |
| | 50 | 35SR26 | 45 | 1.0 | 3.8 | 23 | 21 | 11-3/8 | 9-1/2 | 4 | 4-7/8 |
| | 90 | 135SR46 | 65 | 1.5 | 5.7 | 33 | | | | | |
| | 180 | 141SR46 | 85 | 3.5 | 9.7 | 45 | 25 | 11-5/8 | 9-3/4 | 4-1/2 | 4-7/8 |
| 2 | 25 | 36SR17 | 45 | 1.0 | 4.2 | 23 | | | | | |
| | 50 | 36SR27 | 45 | 1.0 | 4.2 | 23 | 31 | 12-3/8 | 10-1/8 | 5-3/8 | 6 |
| | 115 | 42SR47 | 60 | 1.7 | 7.3 | 35 | | | | | |
| 2-1/2 | 180 | 142SR47 | 85 | 3.5 | 11.0 | 45 | 36 | 12-5/8 | 10-3/8 | 5-3/8 | 6 |
| | 25 | 43SR18 | 60 | 1.7 | 8.0 | 35 | | | | | |
| | 50 | 43SR28 | 60 | 1.7 | 8.0 | 35 | 45 | 13-1/2 | 10-3/4 | 5-7/8 | 7-1/4 |
| 3 | 115 | 43SR48 | 85 | 3.5 | 12.0 | 45 | | | | | |
| | 175 | 143SR48 | 85 | 3.5 | 12.0 | 45 | | | | | |
| | 25 | 44SR19 | 60 | 1.7 | 8.8 | 35 | 57 | 14-3/8 | 11-1/8 | 6-5/8 | 8-3/8 |
| | 50 | 44SR29 | 60 | 1.7 | 8.8 | 35 | | | | | |
| 3 | 100 | 44SR49 | 85 | 3.5 | 13.0 | 45 | | | | | |
| | 150 | 144SR49 | 85 | 3.5 | 13.0 | 45 | | | | | |

† UL Listed Valves - Consult Factory †† Not available for DC operation

MAGNATROL VALVE CORPORATION



BRONZE SOLENOID VALVES

Dependable • Packless

TYPE "L" FULL PORT - NORMALLY CLOSED 1/2" TO 3" PIPE SIZE

NO DIFFERENTIAL PRESSURE REQUIRED TO OPEN

MAX. FLUID TEMP.
400° F

MAX. STATIC PRESSURE
300 PSI

Except valves listed for 500 PSI



OPERATION:

Valve opens when energized and closes when de-energized. When the coil is energized the pilot valve opens, relieving the pressure above the piston, which is then lifted from its seat by the plunger. Upon de-energizing the coil, a spring closes the pilot valve and opens a bleed passageway to permit pressure to build above the piston and seat it.

CONSTRUCTION: (* Wetted parts)

- *Valve Body - Cast Bronze, Globe Pattern - NPT ends
- *Piston - Bronze
- Coil Enclosure - Malleable or Cast Iron, 1/2" NPT conduit conn.
- *Plunger - 430 Stainless Steel
- *Pilot Valve - 303 Stainless Steel
- *Bonnet Tube - 304 Stainless Steel
- *Spring - Inconel
- *Body Seal - Non Asbestos Gasket
- *Orifice Seal - Glass Filled Teflon
- *AC Shading Coil - Copper
- *Stem Pin - Inconel
- Coil - Encapsulated Class H, 18" leads

**FOR OPTIONS &
ACCESSORIES
SEE PAGES 24 & 25**

**FOR
STEAM APPLICATIONS
SEE BULLETIN 3006-S
Page 12**

APPLICATION:

To control the flow of Hot Liquids, Hot Gases, Cryogenics** and any other fluids not reactive with construction materials and free of sediment. Cryogenic fluids include Liquid Oxygen (-297°F), Liquid Argon (-303°F) and Liquid Nitrogen (-320°F). Valve operates from zero to maximum differential pressure indicated in table. Valve must be mounted in horizontal pipe with solenoid enclosure vertical and on top.

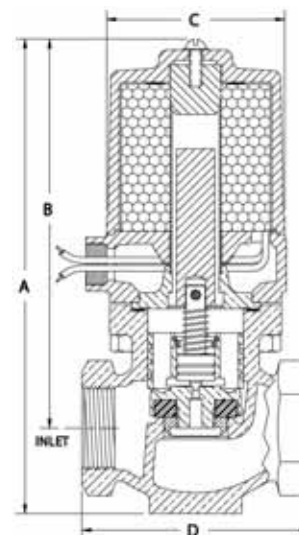

| Pipe Size Inches | Max. Diff. PSI | Type No. | Watts AC | Amps Hold 120-60 | Amps Inrush 120-60 | Watts DC | Ship Wt. Lbs. | Dimensions In Inches | | | |
|------------------|----------------|-----------|----------|------------------|--------------------|----------|---------------|----------------------|--------|-------|-------|
| | | | | | | | | A | B | C | D |
| 1/2 | 110 | 14L42 | 25 | 0.4 | 1.2 | 18 | 8 | 7 | 5-7/8 | 2-7/8 | 3-1/4 |
| | 200 | 14L32 | 25 | 0.4 | 1.3 | 18 | 9 | 7-1/8 | 6 | 2-7/8 | 3-1/2 |
| | 300 | 29L52 | 45 | 0.8 | 2.4 | 23 | 11 | 8 | 6-7/8 | 3-1/2 | 3-1/4 |
| | 500 | E29L62 | 45 | 0.8 | 2.4 | 23 | 16 | 8 | 6-7/8 | 4 | 3-1/4 |
| 3/4 | 50 | 14L23 | 25 | 0.4 | 1.3 | 18 | 9 | 7-1/8 | 6 | 2-7/8 | 3-1/2 |
| | 110 | 14L43 | 25 | 0.4 | 1.3 | 18 | 9 | 7-1/8 | 6 | 2-7/8 | 3-1/2 |
| | 200 | 29L33 | 45 | 0.8 | 2.6 | 23 | 12 | 8-1/8 | 7 | 3-1/2 | 3-1/2 |
| | 300 | 129L53 | 65 | 1.2 | 3.9 | 33 | 17 | 8-1/8 | 7 | 4 | 3-1/2 |
| | 500 | E129L63 | 65 | 1.2 | 3.9 | 33 | 17 | 8-1/8 | 7 | 4 | 3-1/2 |
| 1 | 50 | 16L24 | 25 | 0.4 | 1.5 | 18 | 11 | 8 | 6-5/8 | 3-1/4 | 4-1/8 |
| | 110 | 16L44 | 25 | 0.4 | 1.5 | 18 | 11 | 8 | 6-5/8 | 3-1/4 | 4-1/8 |
| | 200 | 31L34 | 45 | 0.8 | 2.8 | 23 | 14 | 8-7/8 | 7-1/2 | 3-1/2 | 4-1/8 |
| | 300 | 131L54 | 65 | 1.2 | 4.2 | 33 | 19 | 8-7/8 | 7-1/2 | 4 | 4-1/8 |
| | 500 | E131L64 | 65 | 1.2 | 4.2 | 33 | 19 | 8-7/8 | 7-1/2 | 4 | 4-1/8 |
| 1-1/4 | 50 | 17L25 | 25 | 0.4 | 1.6 | 18 | 12 | 8-3/8 | 6-3/4 | 3-1/2 | 4-1/2 |
| | 90 | 17L45 | 25 | 0.4 | 1.6 | 18 | 12 | 8-3/8 | 6-3/4 | 3-1/2 | 4-1/2 |
| | 200 | 32L35 | 45 | 0.8 | 3.0 | 23 | 16 | 9-3/8 | 7-3/4 | 3-5/8 | 4-1/2 |
| | 300 | 132L55 | 65 | 1.2 | 4.5 | 33 | 20 | 10-3/8 | 8-3/4 | 4-1/2 | 4-1/2 |
| | 500 | †† 140L65 | 85 | 2.0 | 9.2 | N/A | 20 | 10-3/8 | 8-3/4 | 4-1/2 | 4-1/2 |
| 1-1/2 | 50 | 35L26 | 45 | 0.8 | 3.2 | 23 | 20 | 10 | 8-1/8 | 4 | 4-7/8 |
| | 115 | 35L46 | 45 | 0.8 | 3.2 | 23 | 20 | 10 | 8-1/8 | 4 | 4-7/8 |
| | 200 | 41L36 | 60 | 1.2 | 6.7 | 35 | 24 | 11 | 9-1/8 | 4-1/2 | 4-7/8 |
| | 300 | 141L56 | 85 | 2.0 | 10.0 | 45 | 24 | 11 | 9-1/8 | 4-1/2 | 4-7/8 |
| | 500 | 141L66 | 85 | 2.0 | 10.0 | 45 | 24 | 11 | 9-1/8 | 4-1/2 | 4-7/8 |
| 2 | 50 | 36L27 | 45 | 0.8 | 3.5 | 23 | 31 | 11 | 8-3/4 | 5-3/8 | 6 |
| | 100 | 36L47 | 45 | 0.8 | 3.5 | 23 | 31 | 11 | 8-3/4 | 5-3/8 | 6 |
| | 200 | 42L37 | 60 | 1.2 | 7.4 | 35 | 36 | 12 | 9-3/4 | 5-3/8 | 6 |
| | 300 | 42L57 | 60 | 1.2 | 7.4 | 35 | 36 | 12 | 9-3/4 | 5-3/8 | 6 |
| | 500 | 142L67 | 85 | 2.0 | 11.0 | 45 | 36 | 12 | 9-3/4 | 5-3/8 | 6 |
| 2-1/2 | 50 | 43L28 | 60 | 1.2 | 8.0 | 35 | 43 | 12-7/8 | 10-1/8 | 5-7/8 | 7-1/4 |
| | 125 | 43L48 | 60 | 1.2 | 8.0 | 35 | 43 | 12-7/8 | 10-1/8 | 5-7/8 | 7-1/4 |
| | 200 | 43L38 | 60 | 1.2 | 8.0 | 35 | 43 | 12-7/8 | 10-1/8 | 5-7/8 | 7-1/4 |
| | 300 | 143L58 | 85 | 2.0 | 12.0 | 45 | 43 | 12-7/8 | 10-1/8 | 5-7/8 | 7-1/4 |
| | 500 | 143L58 | 85 | 2.0 | 12.0 | 45 | 43 | 12-7/8 | 10-1/8 | 5-7/8 | 7-1/4 |
| 3 | 50 | 44L29 | 60 | 1.2 | 8.8 | 35 | 56 | 13-3/4 | 10-1/2 | 6-5/8 | 8-3/8 |
| | 100 | 44L49 | 60 | 1.2 | 8.8 | 35 | 56 | 13-3/4 | 10-1/2 | 6-5/8 | 8-3/8 |
| | 200 | 44L39 | 60 | 1.2 | 8.8 | 35 | 56 | 13-3/4 | 10-1/2 | 6-5/8 | 8-3/8 |
| | 300 | 144L59 | 85 | 2.0 | 13.0 | 45 | 56 | 13-3/4 | 10-1/2 | 6-5/8 | 8-3/8 |
| | 500 | 144L59 | 85 | 2.0 | 13.0 | 45 | 56 | 13-3/4 | 10-1/2 | 6-5/8 | 8-3/8 |

†† Not available for DC operation

**** CLEANING**

- Cryogenic valves are degreased & cleaned to keep them free of moisture.
- Oxygen valves are also "black light" tested.

Strainers are recommended for use with solenoid valves

(See page 19)

When you order please supply the following:

- Pipe Size
- Valve Type
- Voltage (AC or DC)
- Hertz
- Fluid
- Fluid Temperature
- Max. Diff. Pressure
- Optional Features

(See pages 24 & 25)

BRONZE SOLENOID VALVES

Dependable • Packless



TYPE "LR" FULL PORT - NORMALLY OPEN 1/2" TO 3" PIPE SIZE

NO DIFFERENTIAL PRESSURE REQUIRED TO OPEN

OPERATION:

Valve closes when energized and opens when de-energized. When the coil is energized the plunger presses the poppet, closing the pilot orifice, and opens a bleed passageway to permit pressure to build above the piston and seal it. Upon de-energizing the coil, the pilot orifice is opened, relieving the pressure above the piston allowing it to leave its seat. The bottom spring allows the valve to operate at zero pressure drop.

MAX. FLUID TEMP.
400° F

MAX. STATIC PRESSURE
300 PSI

Except valves listed for 500 PSI

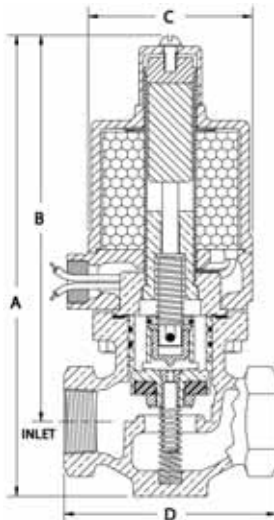

CONSTRUCTION: (* Wetted parts)

- *Valve Body - Cast Bronze, Globe Pattern - NPT ends
- *Piston - Bronze
- Coil Enclosure - Malleable or Cast Iron, 1/2" NPT conduit conn.
- *Plunger - 430 Stainless Steel
- *Poppet - 303 Stainless Steel
- *Stem - 303 Stainless Steel
- *Bonnet Tube - 304 Stainless Steel
- *Springs - Inconel and 302 Stainless Steel
- *Body Seal - Non Asbestos Gasket
- *Orifice Seal - Glass Filled Teflon
- *AC Shading Coil - Copper
- *Stem Pin - 304 Stainless Steel
- Coil - Encapsulated Class H, 18" leads

**FOR OPTIONS & ACCESSORIES
SEE PAGES 24 & 25**

**FOR STEAM APPLICATIONS
SEE BULLETIN 3006-SR
Page 13**



APPLICATION:

To control the flow of Hot Liquids, Hot Gases, Cryogenics** and any other fluids not reactive with construction materials and free of sediment. Cryogenic fluids include Liquid Oxygen (-297°F), Liquid Argon (-303°F) and Liquid Nitrogen (-320°F). Valve operates from zero to maximum differential pressure indicated in table. Valve must be mounted in horizontal pipe with solenoid enclosure vertical and on top.

**** CLEANING**

- Cryogenic valves are degreased & cleaned to keep them free of moisture.
- Oxygen valves are also "black light" tested.

Strainers are recommended for use with solenoid valves

(See page 19)

When you order please supply the following:

- Pipe Size
- Valve Type
- Voltage (AC or DC)
- Hertz
- Fluid
- Fluid Temperature
- Max. Diff. Pressure
- Optional Features

(See pages 24 & 25)

| Pipe Size Inches | Max. Diff. PSI | Type No. | Watts AC | Amps Hold 120-60 | Amps Inrush 120-60 | Watts DC | Ship Wt. Lbs. | Dimensions In Inches | | | |
|------------------|----------------|----------|----------|------------------|--------------------|----------|---------------|----------------------|--------|-------|-------|
| | | | | | | | | A | B | C | D |
| 1/2 | 110 | 14LR42 | 25 | 0.5 | 1.5 | 18 | 8 | 8-1/8 | 7 | 2-7/8 | 3-1/4 |
| | 200 | 14LR32 | 45 | 1.0 | 2.7 | 23 | 11 | 9-1/8 | 8 | 3-1/2 | 3-1/4 |
| | 300 | 29LR52 | 45 | 1.0 | 2.7 | 23 | 16 | 9-1/8 | 8 | 4 | 3-1/4 |
| 3/4 | 50 | 14LR23 | 25 | 0.5 | 1.6 | 18 | 9 | 8-1/4 | 7-1/8 | 2-7/8 | 3-1/2 |
| | 110 | 14LR43 | 45 | 1.0 | 2.9 | 23 | 13 | 9-1/4 | 8-1/8 | 3-1/2 | 3-1/2 |
| | 200 | 29LR33 | 65 | 1.5 | 4.3 | 33 | | | | | |
| | 300 | 129LR53 | 65 | 1.5 | 4.3 | 33 | 18 | 9-1/4 | 8-1/8 | 4 | 3-1/2 |
| | 500 | E129LR63 | 65 | 1.5 | 4.3 | 33 | 18 | 9-1/4 | 8-1/8 | 4 | 3-1/2 |
| 1 | 50 | 16LR24 | 25 | 0.5 | 1.8 | 18 | 11 | 9-1/8 | 7-3/4 | 3-1/4 | 4-1/8 |
| | 110 | 16LR44 | 45 | 1.0 | 3.0 | 23 | 15 | 10 | 8-5/8 | 3-1/2 | 4-1/8 |
| | 200 | 31LR34 | 65 | 1.5 | 4.5 | 33 | | | | | |
| | 300 | 131LR54 | 65 | 1.5 | 4.5 | 33 | 20 | 10 | 8-5/8 | 4 | 4-1/8 |
| 1-1/4 | 50 | 17LR25 | 25 | 0.5 | 1.9 | 18 | 13 | 9-3/4 | 8-1/8 | 3-1/2 | 4-1/2 |
| | 90 | 17LR45 | 45 | 1.0 | 3.2 | 23 | 17 | 10-3/4 | 9-1/8 | 3-5/8 | 4-1/2 |
| | 200 | 32LR35 | 65 | 1.5 | 4.8 | 33 | | | | | |
| | 300 | 132LR55 | 85 | 3.5 | 9.0 | N/A | 20 | 11 | 9-3/8 | 4-1/2 | 4-1/2 |
| 1-1/2 | 50 | 35LR26 | 45 | 1.0 | 3.8 | 23 | 21 | 11-3/8 | 9-3/8 | 4 | 4-7/8 |
| | 115 | 35LR46 | 60 | 1.7 | 6.5 | 35 | 25 | 11-5/8 | 9-3/4 | 4-1/2 | 4-7/8 |
| | 200 | 41LR36 | 85 | 3.5 | 9.7 | 45 | | | | | |
| | 300 | 141LR56 | 45 | 1.0 | 4.2 | 23 | 31 | 12-3/8 | 10-1/8 | 5-3/8 | 6 |
| | 500 | 141LR66 | 60 | 1.7 | 7.3 | 35 | | | | | |
| 2 | 50 | 36LR27 | 45 | 1.0 | 4.2 | 23 | 36 | 12-5/8 | 10-3/8 | 5-3/8 | 6 |
| | 100 | 36LR47 | 60 | 1.7 | 7.3 | 35 | | | | | |
| | 200 | 42LR37 | 85 | 3.5 | 11.0 | 45 | 45 | 13-1/2 | 10-3/4 | 5-7/8 | 7-1/4 |
| | 300 | 42LR57 | 60 | 1.7 | 8.0 | 35 | | | | | |
| 2-1/2 | 50 | 43LR28 | 45 | 1.0 | 4.2 | 23 | 31 | 12-3/8 | 10-1/8 | 5-3/8 | 6 |
| | 100 | 36LR47 | 60 | 1.7 | 7.3 | 35 | | | | | |
| | 125 | 43LR48 | 60 | 1.7 | 8.0 | 35 | 45 | 13-1/2 | 10-3/4 | 5-7/8 | 7-1/4 |
| | 200 | 43LR38 | 85 | 3.5 | 12.0 | 45 | | | | | |
| 3 | 50 | 44LR29 | 45 | 1.0 | 4.2 | 23 | 31 | 12-3/8 | 10-1/8 | 5-3/8 | 6 |
| | 100 | 44LR49 | 60 | 1.7 | 8.8 | 35 | | | | | |
| | 200 | 44LR39 | 60 | 1.7 | 8.8 | 35 | 57 | 14-3/8 | 11-1/8 | 6-5/8 | 8-3/8 |
| | 300 | 144LR59 | 85 | 3.5 | 13.0 | 45 | | | | | |

†† Not available for DC operation



BRONZE SOLENOID VALVES

Dependable • Packless

MAX. FLUID TEMP.
212° F
MAX. STATIC PRESSURE
150 PSI

TYPE "G" FULL PORT - NORMALLY CLOSED 1" TO 3" PIPE SIZE

NO DIFFERENTIAL PRESSURE REQUIRED TO OPEN

OPERATION:

Valve opens when energized and closes when de-energized. When the coil is energized the pilot valve opens, relieving the pressure above the piston, which is then lifted from its seat by the plunger. Upon de-energizing the coil, a spring closes the pilot valve and opens a bleed passageway to permit pressure to build above the piston and seat it.

CONSTRUCTION: (* Wetted parts)

- *Valve Body - Cast Bronze, Globe Pattern - NPT ends
- *Piston - Bronze
- Coil Enclosure - Malleable or Cast Iron, 1/2" NPS conduit conn.
- *Plunger - 430 Stainless Steel
- *Pilot Valve Stem - 303 Stainless Steel
- *Pilot Valve Disc Holder - Brass
- *Pilot Valve Seal - Buna N (Viton available)
- *Bonnet Tube - 304 Stainless Steel
- *Spring - 302 Stainless Steel
- *Body Seal - Buna N or Non Asbestos Gasket
- *Orifice Seal - Buna N (Viton or Glass Filled Teflon available)
- *AC Shading Coil - Copper
- *Stem Pin - Inconel
- Coil - Encapsulated Class B, 18" leads - (Class H available)

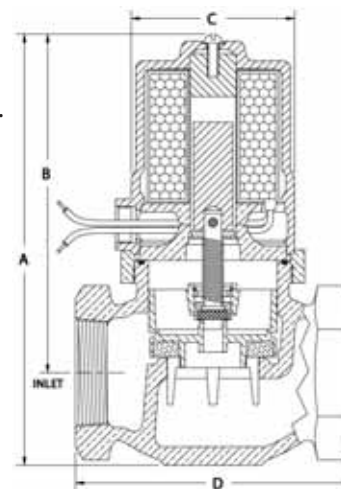

**FOR OPTIONS & ACCESSORIES
SEE PAGES 24 & 25**

APPLICATION:

To control the flow of Water, Air, Gas, Solvents, Vacuum and any other fluids not reactive with construction materials and free of sediment. Buna N seating of the pilot and main orifices make the valves ideal for TIGHT SEATING, LOW PRESSURE and LOW FLOW conditions. Valve operates from zero to maximum differential pressure indicated in table. Valve must be mounted in horizontal pipe with solenoid enclosure vertical and on top.

Strainers are recommended for use with solenoid valves
(See page 19)

| Pipe Size Inches | Max. Diff. PSI | Type No. | Watts AC | Amps Hold 120-60 | Amps Inrush 120-60 | Watts DC | Ship Wt. Lbs. | Dimensions In Inches | | | |
|------------------|----------------|----------|----------|------------------|--------------------|----------|---------------|----------------------|-------|-------|-------|
| | | | | | | | | A | B | C | D |
| 1 | 20 | † 18G24 | 25 | 0.4 | 1.4 | 18 | 9 | 7-1/2 | 6-1/8 | 2-3/4 | 4-1/8 |
| | 30 | 118G24 | 40 | 0.6 | 2.3 | 28 | 9 | 7-1/2 | 6-1/8 | 2-3/4 | 4-1/8 |
| | 50 | 133G24 | 65 | 1.2 | 4.0 | 33 | 13 | 8-1/2 | 7-1/8 | 3-1/2 | 4-1/8 |
| 1-1/4 | 20 | † 18G25 | 25 | 0.4 | 1.5 | 18 | 10 | 8 | 6-3/8 | 2-7/8 | 4-3/8 |
| | 30 | 118G25 | 40 | 0.6 | 2.4 | 28 | 10 | 8 | 6-3/8 | 2-7/8 | 4-3/8 |
| | 50 | 133G25 | 65 | 1.2 | 4.1 | 33 | 14 | 8-7/8 | 7-3/8 | 3-1/2 | 4-3/8 |
| 1-1/2 | 15 | † 18G26 | 25 | 0.4 | 1.7 | 18 | 12 | 8-1/8 | 6-1/2 | 3-1/8 | 4-3/4 |
| | 25 | 118G26 | 40 | 0.6 | 2.5 | 28 | 12 | 8-1/8 | 6-1/2 | 3-1/8 | 4-3/4 |
| | 35 | 133G26 | 65 | 1.2 | 4.2 | 33 | 16 | 9-1/8 | 7-1/2 | 3-1/2 | 4-3/4 |
| 2 | 18 | 33G27 | 45 | 0.8 | 3.4 | 23 | 20 | 9-7/8 | 7-7/8 | 3-3/4 | 5-3/4 |
| | 30 | 133G27 | 65 | 1.2 | 4.2 | 33 | 20 | 9-7/8 | 7-7/8 | 3-3/4 | 5-3/4 |
| | 50 | 233G27 | 80 | 1.8 | 9.0 | 40 | 20 | 9-7/8 | 7-7/8 | 3-3/4 | 5-3/4 |
| 2-1/2 | 13 | 37G28 | 40 | 0.8 | 3.6 | 23 | 33 | 11-1/8 | 8-5/8 | 5-7/8 | 7-1/8 |
| | 25 | 43G28 | 60 | 1.2 | 7.8 | 35 | 38 | 12-1/8 | 9-5/8 | 5-7/8 | 7-1/8 |
| | 35 | 143G28 | 85 | 2.0 | 12.0 | 45 | 38 | 12-1/8 | 9-5/8 | 5-7/8 | 7-1/8 |
| 3 | 25 | 44G29 | 60 | 1.2 | 8.6 | 35 | 46 | 13 | 10 | 6-5/8 | 8 |
| | 35 | 144G29 | 85 | 2.0 | 13.0 | 45 | 46 | 13 | 10 | 6-5/8 | 8 |

When you order please supply the following:

- Pipe Size
 - Valve Type
 - Voltage (AC or DC)
 - Hertz
 - Fluid
 - Fluid Temperature
 - Max. Diff. Pressure
 - Optional Features
- (See pages 24 & 25)

† UL Listed Valves - Consult Factory

BRONZE SOLENOID VALVES

Dependable • Packless



TYPE "GR" FULL PORT - NORMALLY OPEN 1" TO 3" PIPE SIZE

NO DIFFERENTIAL PRESSURE REQUIRED TO OPEN

MAX. FLUID TEMP.
212° F
MAX. STATIC PRESSURE
150 PSI

OPERATION:

Valve closes when energized and opens when de-energized. When the coil is energized the plunger presses the poppet, closing the pilot orifice, and opens a bleed passageway to permit pressure to build above the piston and seat it. Upon de-energizing the coil, the pilot orifice is opened, relieving the pressure above the piston allowing it to leave its seat. The bottom spring allows the valve to operate at zero pressure drop.

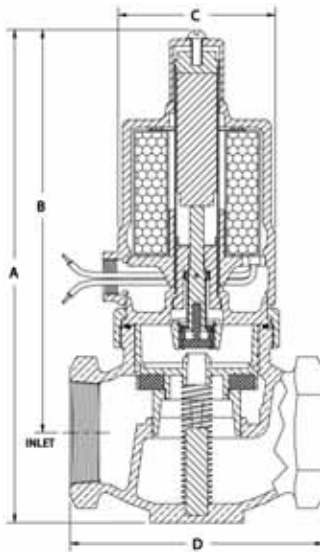

Strainers are recommended for use with solenoid valves
(See page 19)

CONSTRUCTION: (* Wetted parts)

- *Valve Body - Cast Bronze, Globe Pattern - NPT ends
- *Piston - Bronze
Coil Enclosure - Malleable or Cast Iron, 1/2" NPS conduit conn.
- *Plunger - 430 Stainless Steel
- *Pilot Valve Stem - 303 Stainless Steel
- *Pilot Valve Disc Holder - Brass
- *Pilot Valve Seal - Buna N (Viton available)
- *Bonnet Tube - 304 Stainless Steel
- *Spring - 302 Stainless Steel
- *Body Seal - Buna N or Non Asbestos Gasket
- *Orifice Seal - Buna N (Viton or Glass Filled Teflon available)
- *AC Shading Coil - Copper
- *Stem Pin - Inconel
Coil - Encapsulated Class B, 18" leads - (Class H available)



APPLICATION:

To control the flow of Water, Air, Gas, Solvents, Vacuum and any other fluids not reactive with construction materials and free of sediment. Buna N seating of the pilot and main orifices make the valves ideal for TIGHT SEATING, LOW PRESSURE and LOW FLOW conditions. Valve operates from zero to maximum differential pressure indicated in table. Valve must be mounted in horizontal pipe with solenoid enclosure vertical and on top.

**FOR OPTIONS & ACCESSORIES
SEE PAGES 24 & 25**

When you order please supply the following:

- Pipe Size
- Valve Type
- Voltage (AC or DC)
- Hertz
- Fluid
- Fluid Temperature
- Max. Diff. Pressure
- Optional Features

(See pages 24 & 25)

| Pipe Size Inches | Max. Diff. PSI | Type No. | Watts AC | Amps Hold 120-60 | Amps Inrush 120-60 | Watts DC | Ship Wt. Lbs. | Dimensions In Inches | | | |
|------------------|----------------|----------|----------|------------------|--------------------|----------|---------------|----------------------|--------|-------|-------|
| | | | | | | | | A | B | C | D |
| 1 | 20 | † 18GR24 | 25 | 0.5 | 1.5 | 18 | 9 | 8-5/8 | 7-1/4 | 2-3/4 | 4-1/8 |
| | 35 | 33GR24 | 45 | 1.0 | 3.0 | 23 | 13 | 9-5/8 | 8-1/4 | 3-1/2 | 4-1/8 |
| 1-1/4 | 20 | † 18GR25 | 25 | 0.5 | 1.9 | 18 | 10 | 9-3/8 | 7-3/4 | 2-7/8 | 4-3/8 |
| | 35 | 33GR25 | 45 | 1.0 | 3.2 | 23 | 14 | 10-1/4 | 8-3/4 | 3-1/2 | 4-3/8 |
| 1-1/2 | 15 | † 18GR26 | 25 | 0.5 | 2.0 | 18 | 12 | 9-1/2 | 7-7/8 | 3-1/8 | 4-3/4 |
| | 25 | 33GR26 | 45 | 1.0 | 3.8 | 23 | 16 | 10-1/2 | 8-7/8 | 3-1/2 | 4-3/4 |
| 2 | 18 | 33GR27 | 45 | 1.0 | 4.2 | 23 | 21 | 11-1/4 | 9-1/4 | 3-3/4 | 5-3/4 |
| | 30 | 133GR27 | 65 | 1.5 | 4.5 | 33 | 21 | 11-1/4 | 9-1/4 | 3-3/4 | 5-3/4 |
| 2-1/2 | 13 | 37GR28 | 45 | 1.0 | 4.4 | 23 | 34 | 12-1/2 | 10 | 5-7/8 | 7-1/8 |
| | 25 | 43GR28 | 60 | 1.7 | 8.0 | 35 | 39 | 12-3/4 | 10-1/4 | 5-7/8 | 7-1/8 |
| 3 | 25 | 44GR29 | 60 | 1.7 | 8.8 | 35 | 47 | 13-5/8 | 10-5/8 | 6-5/8 | 8 |

† UL Listed Valves - Consult Factory

MAGNATROL VALVE CORPORATION



BRONZE SOLENOID VALVES

Dependable • Packless

TYPE "D" FULL PORT - NORMALLY CLOSED 3/8" TO 2" PIPE SIZE

NO DIFFERENTIAL PRESSURE REQUIRED TO OPEN

MAX. FLUID TEMP.
212° F
MAX. STATIC PRESSURE
150 PSI

OPERATION:

Valve opens when energized and closes when de-energized. In this direct acting valve the disc holder assembly is lifted from its seat by the plunger.

CONSTRUCTION: (* Wetted parts)

- *Valve Body - Cast Bronze, Globe Pattern - NPT ends
- *Disc Holder - Brass
- Coil Enclosure - Malleable or Cast Iron, 1/2" NPS conduit conn.
- *Plunger - 430 Stainless Steel
- *Stem - 303 Stainless Steel
- *Bonnet Tube - 304 Stainless Steel
- *Spring - 302 Stainless Steel
- *Body Seal - Buna N
- *Orifice Seal - Buna N (Viton or Glass Filled Teflon available)
- *AC Shading Coil - Copper
- *Stem Pin - Inconel
- Coil - Encapsulated Class B, 18" leads - (Class H available)

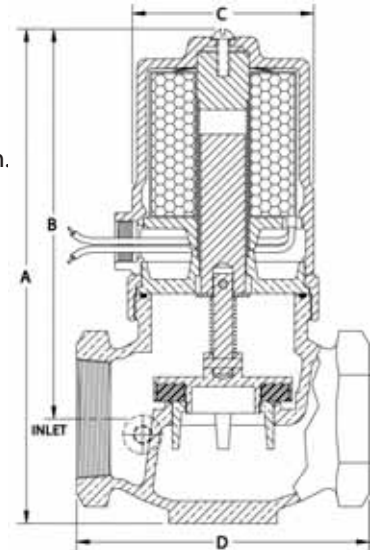

APPLICATION:

To control the flow of Water, Air, Gas, Solvents, Vacuum and any other fluids not reactive with construction materials and free of sediment. Buna N seating of the main orifice make the valves ideal for TIGHT SEATING, LOW PRESSURE and LOW FLOW conditions. Valve operates from zero to maximum differential pressure indicated in table. Valve must be mounted in horizontal pipe with solenoid enclosure vertical and on top.

Strainers are recommended for use with solenoid valves (See page 19)

FOR OPTIONS & ACCESSORIES
SEE PAGES 24 & 25



| Pipe Size Inches | Max. Diff. PSI | Type No. | Watts AC | Amps Hold 120-60 | Amps Inrush 120-60 | Watts DC | Ship Wt. Lbs. | Dimensions In Inches | | | |
|------------------|----------------|----------|----------|------------------|--------------------|----------|---------------|----------------------|-------|-------|-------|
| | | | | | | | | A | B | C | D |
| 3/8 | 15 | 18D11 | 25 | 0.4 | 1.0 | 18 | 7 | 6-1/4 | 5-3/8 | 2-3/4 | 2-7/8 |
| | 30 | 33D11 | 45 | 0.8 | 2.3 | 23 | 10 | 7-1/8 | 6-3/8 | 3-1/2 | 2-7/8 |
| 1/2 | 10 | 18D12 | 25 | 0.4 | 1.1 | 18 | 7 | 6-1/4 | 5-1/2 | 2-3/4 | 3-1/8 |
| | 20 | 33D12 | 45 | 0.8 | 2.4 | 23 | 10 | 7-1/4 | 6-3/8 | 3-1/2 | 3-1/8 |
| 3/4 | 4 | 18D13 | 25 | 0.4 | 1.2 | 18 | 8 | 6-7/8 | 5-3/4 | 2-3/4 | 3-1/2 |
| | 7.5 | 33D13 | 45 | 0.8 | 2.5 | 23 | 12 | 7-3/4 | 6-3/4 | 3-1/2 | 3-1/2 |
| 1 | 2 | 18D14 | 25 | 0.4 | 1.4 | 18 | 9 | 7-1/2 | 6-1/8 | 2-3/4 | 4-1/8 |
| | 3.5 | 33D14 | 45 | 0.8 | 2.7 | 23 | 13 | 8-1/2 | 7-1/8 | 3-1/2 | 4-1/8 |
| 1-1/4 | 1.3 | 18D15 | 25 | 0.4 | 1.5 | 18 | 10 | 8 | 6-3/8 | 2-7/8 | 4-3/8 |
| | 2.3 | 33D15 | 45 | 0.8 | 2.8 | 23 | 14 | 8-7/8 | 7-3/8 | 3-1/2 | 4-3/8 |
| 1-1/2 | 0.8 | 18D16 | 25 | 0.4 | 1.7 | 18 | 12 | 8-1/8 | 6-1/2 | 3-1/8 | 4-3/4 |
| | 1.5 | 33D16 | 45 | 0.8 | 3.0 | 23 | 15 | 9-1/8 | 7-1/2 | 3-1/2 | 4-3/4 |
| 2 | 0.8 | 33D17 | 45 | 0.8 | 3.4 | 23 | 19 | 9-7/8 | 7-7/8 | 3-3/4 | 5-3/4 |
| | 1.2 | †133D17 | 65 | 1.2 | 4.2 | 33 | 19 | 9-7/8 | 7-7/8 | 3-3/4 | 5-3/4 |

When you order please supply the following:

- Pipe Size
 - Valve Type
 - Voltage (AC or DC)
 - Hertz
 - Fluid
 - Fluid Temperature
 - Max. Diff. Pressure
 - Optional Features
- (See pages 24 & 25)

† UL Listed Valves - Consult Factory

STRAINERS

Bronze • Stainless Steel



APPLICATION:

The presence of foreign particles in an automatic valve may seriously affect its dependability. The installation of a strainer close to the inlet side of the valve is the best means of preventing the entrance of pipe chips, scale, rust, pipe dope, welding slag or sediment into the valve, provided the screen is periodically removed for cleaning.

CONSTRUCTION:

Strainer bodies have screwed ends. Screens are stainless steel with opening sizes as listed in tables below. Other sizes can be furnished upon request. Liberal straining area provides for fluid passage at minimum pressure drop. Screens are easily removed for cleaning. Strainers are furnished with NPT blow-off connections unplugged. See charts below for blow-off sizes (C Dim.)

CLEANING FOR CRYOGENIC & OXYGEN SERVICE:

- Strainers for Cryogenic applications are degreased and cleaned to keep them free of moisture.
- Strainers for Oxygen service are degreased and cleaned then “black light” tested.



BRONZE 1/4" TO 3" PIPE SIZE

| Pipe Size Inches | Screen Size | Type No. | Ship Wt. Lbs. | Dimensions In Inches | | |
|------------------|--|----------|---------------|----------------------|--------|-------|
| | | | | A | B | C |
| 1/4 | 60 Mesh 0.009 Openings | ST 0 | 3/4 | 2-3/4 | 2-1/4 | 1/4 |
| 3/8 | | ST 1 | 3/4 | 2-3/4 | 2-1/4 | 1/4 |
| 1/2 | | ST 2 | 3/4 | 2-3/4 | 2-1/4 | 1/4 |
| 3/4 | | ST 3 | 1-1/2 | 3 | 2-9/16 | 3/8 |
| 1 | 0.16 Diameter Perforations Lined With 30 Mesh | ST 4 | 2-1/4 | 3-3/4 | 2-3/4 | 3/8 |
| 1-1/4 | | ST 5 | 3-1/4 | 4-7/16 | 3-5/8 | 3/4 |
| 1-1/2 | | ST 6 | 4-1/2 | 4-15/16 | 3-7/8 | 3/4 |
| 2 | | ST 7 | 7 | 6-1/8 | 5-1/16 | 1 |
| 2-1/2 | | ST 8 | 12-1/2 | 8-1/4 | 6 | 1-1/4 |
| 3 | ST 9 | 18 | 9 | 6-3/4 | 1-1/2 | |

STAINLESS STEEL 1/2" TO 2" PIPE SIZE

| Pipe Size Inches | Screen Size | Type No. | Ship Wt. Lbs. | Dimensions In Inches | | |
|------------------|--|----------|---------------|----------------------|---------|-----|
| | | | | A | B | C |
| 1/2 | 60 Mesh 0.009 Openings | ST 2SS | 1-1/2 | 3 | 2-3/8 | 1/4 |
| 3/4 | | ST 3SS | 2-1/4 | 3-3/4 | 2-13/16 | 3/8 |
| 1 | | ST 4SS | 3-1/4 | 4-5/8 | 3-1/8 | 3/8 |
| 1-1/2 | 0.16 Diameter Perforations Lined w/30 Mesh | ST 6SS | 6-3/4 | 5-5/8 | 4-3/4 | 3/4 |
| 2 | | ST 7SS | 11-1/2 | 7 | 6 | 1 |

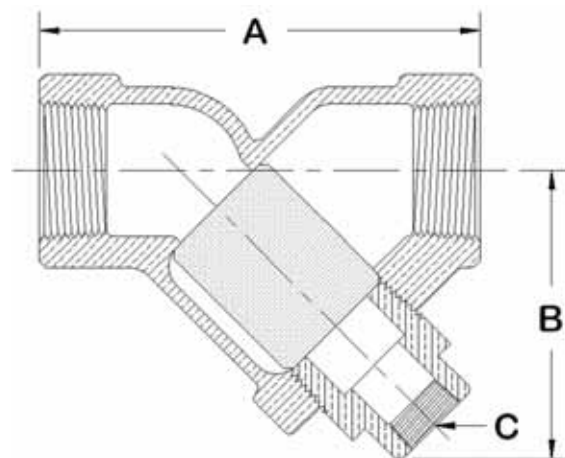

PRESSURE TEMPERATURE RATINGS

| MATERIAL | STEAM | LIQUIDS |
|-----------------|-----------------|-------------------|
| BRONZE | 300 PSI @ 400°F | 600 PSI @ 100°F |
| STAINLESS STEEL | 845 PSI @ 750°F | 1,440 PSI @ 100°F |



STAINLESS STEEL SOLENOID VALVES

Dependable • Packless

TYPE "K" FULL PORT - NORMALLY CLOSED 1/2" TO 3" PIPE SIZE

NO DIFFERENTIAL PRESSURE REQUIRED TO OPEN

MAX. FLUID TEMP.
400° F
MAX. STATIC PRESSURE
300 PSI
Except valves listed for 500 PSI

OPERATION:

Valve opens when energized and closes when de-energized. When the coil is energized the pilot valve opens, relieving the pressure above the piston, which is then lifted from its seat by the plunger. Upon de-energizing the coil, a spring closes the pilot valve and opens a bleed passageway to permit pressure to build above the piston and seat it.

CONSTRUCTION:

- (*Wetted parts - No Copper Bearing Alloys in contact with fluid)
- *Valve Body - 304 Stainless Steel Globe Pattern - NPT ends
(For Flanged Ends see Options page 24)
- *Piston - 303 Stainless Steel
- Coil Enclosure - Malleable or Cast Iron, 1/2" NPS conduit conn.
- *Plunger - 430 Stainless Steel
- *Pilot Valve - 303 Stainless Steel
- *Bonnet Tube - 304 Stainless Steel
- *Spring - Inconel
- *Body Seal - Non Asbestos Gasket
- *Orifice Seal - Glass Filled Teflon
- *AC Shading Coil - Silver
- *Stem Pin - Inconel
- Coil - Encapsulated Class H, 18" leads

**FOR
STEAM APPLICATIONS
SEE BULLETIN 3006-W
Page 22**

APPLICATION:

To control the flow of Corrosive Fluids, Deionized Water, Condensate, Ammonias, Vegetable Oils, Fuel Oils, Cryogenics, Flammable Liquids.** Cryogenic fluids include liquid oxygen (-297°F), liquid argon (-303°F) and liquid nitrogen (-320°F). Valve operates from zero to maximum differential pressure indicated in table. Valve must be mounted in horizontal pipe with solenoid enclosure vertical and on top.

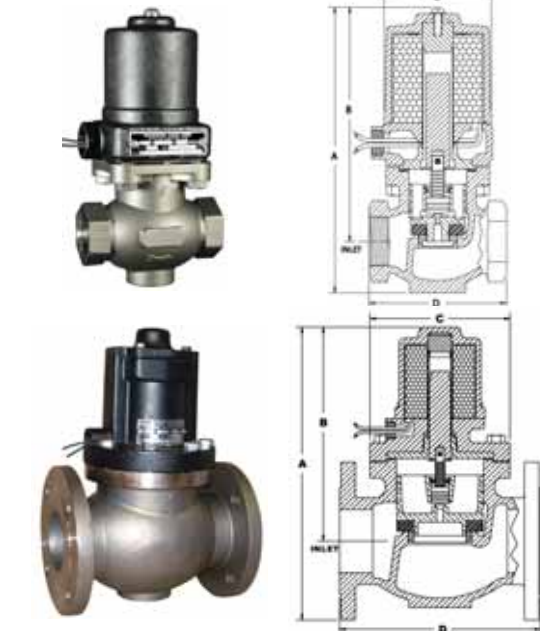

FOR OPTIONS & ACCESSORIES SEE PAGES 24 & 25

| Pipe Size Inches | Max. Diff. PSI | Type No. | Watts AC | Amps Hold 120-60 | Amps Inrush 120-60 | Watts DC | Ship Wt. Lbs. | Dimensions In Inches | | | | | |
|------------------|----------------|----------|----------|------------------|--------------------|----------|---------------|----------------------|--------|--------|-------|-----------------------|-------|
| | | | | | | | | A | B | C | D NPT | D (Flanged) 150# 300# | |
| 1/2 | 110 | 14K42 | 25 | 0.4 | 1.2 | 18 | 7 | 7 | 5-7/8 | 2-7/8 | 2-7/8 | 6 | 6-1/2 |
| | 200 | 14K32 | | | | | | | | | | | |
| | 300 | 29K52 | 45 | 0.8 | 2.4 | 23 | 10 | 8 | 6-7/8 | 3-1/2 | 3-1/2 | | |
| | 500 | E29K62 | | | | | | | | | | | |
| 3/4 | 110 | 14K43 | 25 | 0.4 | 1.3 | 18 | 8 | 7-1/8 | 6 | 2-7/8 | 2-7/8 | 6 | 6-1/2 |
| | 200 | 29K33 | | | | | | | | | | | |
| | 300 | 129K53 | 65 | 1.2 | 3.9 | 33 | 11 | 8-1/8 | 7 | 3-1/2 | 3-1/2 | | |
| | 500 | E129K63 | | | | | | | | | | | |
| 1 | 110 | 16K44 | 25 | 0.4 | 1.5 | 18 | 10 | 8 | 6-5/8 | 3-1/4 | 3-1/4 | 6-1/2 | 7-1/2 |
| | 200 | 31K34 | | | | | | | | | | | |
| | 300 | 131K54 | 65 | 1.2 | 4.2 | 33 | 13 | 8-7/8 | 7-1/2 | 3-1/2 | 3-1/2 | | |
| | 500 | E131K64 | | | | | | | | | | | |
| 1-1/2 | 115 | 35K46 | 45 | 0.8 | 3.2 | 23 | 17 | 10 | 8-1/8 | 4 | 4 | 6-1/2 | 7-1/2 |
| | 200 | 41K36 | | | | | | | | | | | |
| | 300 | 141K56 | 85 | 2.0 | 10.0 | 45 | 21 | 11 | 9-1/8 | 4-1/2 | 4-1/2 | | |
| | 500 | 141K66 | | | | | | | | | | | |
| 2 | 100 | 36K47 | 45 | 0.8 | 3.5 | 23 | 27 | 11 | 8-3/4 | 5-3/8 | 5-3/8 | 8 | 9 |
| | 200 | 42K37 | | | | | | | | | | | |
| | 300 | 42K57 | 85 | 2.0 | 11.0 | 45 | 32 | 12 | 9-3/4 | | | | |
| | 500 | 142K67 | | | | | | | | | | | |
| 3 | 50 | 44K29F1 | 60 | 1.2 | 8.8 | 35 | 68 | 13-3/4 | 10-1/2 | 6-5/8 | N/A | 9-1/2 | N/A |
| | 100 | 44K49F1 | | | | | | | | | | | |
| | 200 | 44K39F1 | 85 | 2.0 | 13.0 | 45 | 81 | N/A | N/A | 12-1/2 | | | |
| | 300 | 144K59F3 | | | | | | | | | | | |

**** CLEANING**

- Cryogenic valves are degreased & cleaned to keep them free of moisture.
- Oxygen valves are also "black light" tested.

Strainers are recommended for use with solenoid valves (See page 19)

When you order please supply the following:

- Pipe Size
 - Valve Type
 - Voltage (AC or DC)
 - Hertz
 - Fluid
 - Fluid Temperature
 - Max. Diff. Pressure
 - Optional Features
- (See pages 24 & 25)

Shipping Weights above apply to Threaded Ends Only (except 3" which are Flanged Only)

For Flanged Ends contact factory for complete weight and dimensions

3" STAINLESS STEEL VALVES ARE SUPPLIED WITH FLANGED ENDS ONLY

MAGNATROL VALVE CORPORATION

STAINLESS STEEL SOLENOID VALVES

Dependable • Packless



TYPE "KR" FULL PORT - NORMALLY OPEN 1/2" TO 3" PIPE SIZE

NO DIFFERENTIAL PRESSURE REQUIRED TO OPEN

OPERATION:

Valve closes when energized and opens when de-energized. When the coil is energized the plunger presses the poppet, closing the pilot orifice, and opens a bleed passageway to permit pressure to build above the piston and seat it. Upon de-energizing the coil, the pilot orifice is opened, relieving the pressure above the piston allowing it to leave its seat. The bottom spring allows the valve to operate at zero pressure drop.

CONSTRUCTION:

(*Wetted parts - No Copper Bearing Alloys in contact with fluid)

*Valve Body - 304 Stainless Steel Globe Pattern - NPT ends

(For Flanged Ends see Options page 24)

*Piston - 303 Stainless Steel

Coil Enclosure - Malleable or Cast Iron, 1/2" NPS conduit conn.

*Plunger - 430 Stainless Steel

*Poppet - 303 Stainless Steel

*Stem - 303 Stainless Steel

*Bonnet Tube - 304 Stainless Steel

*Spring - Inconel

*Body Seal - Non Asbestos Gasket

*Orifice Seal - Glass Filled Teflon

*AC Shading Coil - Silver

*Stem Pin - 304 Stainless Steel

Coil - Encapsulated Class H, 18" leads

**FOR
STEAM APPLICATIONS
SEE BULLETIN 3006-WR
Page 23**

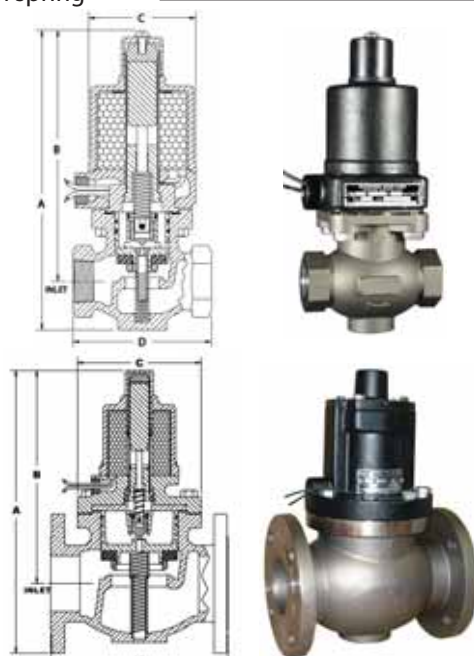

**MAX. FLUID TEMP.
400° F
MAX. STATIC PRESSURE
300 PSI
Except valves listed for 500 PSI**

APPLICATION:

To control the flow of Corrosive Fluids, Deionized Water, Condensate, Ammonias, Vegetable Oils, Fuel Oils, Cryogenics, Flammable Liquids.** Cryogenic fluids include liquid oxygen (-297°F), liquid argon (-303°F) and liquid nitrogen (-320°F). Valve operates from zero to maximum differential pressure indicated in table. Valve must be mounted in horizontal pipe with solenoid enclosure vertical and on top.

FOR OPTIONS & ACCESSORIES SEE PAGES 24 & 25

** CLEANING

- Cryogenic valves are degreased & cleaned to keep them free of moisture.
- Oxygen valves are also "black light" tested.

Strainers are recommended for use with solenoid valves
(See page 19)

When you order please supply the following:

- Pipe Size
 - Valve Type
 - Voltage (AC or DC)
 - Hertz
 - Fluid
 - Fluid Temperature
 - Max. Diff. Pressure
 - Optional Features
- (See pages 24 & 25)

| Pipe Size Inches | Max. Diff. PSI | Type No. | Watts AC | Amps Hold 120-60 | Amps Inrush 120-60 | Watts DC | Ship Wt. Lbs. | Dimensions In Inches | | | | | | |
|------------------|----------------|-----------|----------|------------------|--------------------|----------|---------------|----------------------|--------|-------|-------|-------------|-------|-----|
| | | | | | | | | A | B | C | D | D (Flanged) | | |
| | | | | | | | | | | | | 150# | 300# | |
| 1/2 | 110 | 14KR42 | 25 | 0.5 | 1.5 | 18 | 7 | 8-1/8 | 7 | 2-7/8 | 3-1/4 | 6 | 6-1/2 | |
| | 200 | 14KR32 | | | | | | | | | | | | |
| | 300 | 29KR52 | 45 | 1.0 | 2.7 | 23 | 10 | 9-1/8 | 8 | 3-1/2 | | | | |
| | 500 | E29KR62 | | | | | | | | | | | | 4 |
| 3/4 | 110 | 14KR43 | 25 | 0.5 | 1.6 | 18 | 8 | 8-1/4 | 7-1/8 | 2-7/8 | 3-1/2 | 6 | 6-1/2 | |
| | 200 | 29KR33 | | | | | | | | | | | | |
| | 300 | 129KR53 | 65 | 1.5 | 4.3 | 33 | 12 | 9-1/4 | 8-1/8 | 3-1/2 | | | | |
| | 500 | E129KR63 | | | | | | | | | | | | 4 |
| 1 | 110 | 16KR44 | 25 | 0.5 | 1.8 | 18 | 10 | 9-1/8 | 7-3/4 | 3-1/4 | 4-1/8 | 6-1/2 | 7-1/2 | |
| | 200 | 31KR34 | | | | | | | | | | | | |
| | 300 | 131KR54 | 65 | 1.5 | 4.5 | 33 | 14 | 10 | 8-5/8 | 3-1/2 | | | | |
| | 500 | E131KR64 | | | | | | | | | | | | 4 |
| 1-1/2 | 115 | 35KR46 | 45 | 1.0 | 3.8 | 23 | 18 | 11-3/8 | 9-1/2 | 4 | 4-7/8 | 6-1/2 | 7-1/2 | |
| | 200 | 41KR36 | | | | | | | | | | | | |
| | 300 | 141KR56 | 85 | 3.5 | 9.7 | 45 | 22 | 11-5/8 | 9-3/4 | 4-1/2 | | | | |
| | 500 | 141KR66 | | | | | | | | | | | | 4 |
| 2 | 100 | 36KR47 | 45 | 1.0 | 4.2 | 23 | 27 | 12-3/8 | 10-1/8 | | 5-3/8 | 6 | 8 | 9 |
| | 200 | 42KR37 | | | | | | | | | | | | |
| | 300 | 42KR57 | 85 | 3.5 | 11.0 | 45 | 32 | 12-5/8 | 10-3/8 | | | | | |
| | 500 | 142KR67 | | | | | | | | | | | | |
| 3 | 50 | 44KR29F1 | 60 | 1.7 | 8.8 | 35 | 69 | 14-3/8 | 11-1/8 | 6-5/8 | N/A | 6-1/2 | N/A | |
| | 100 | 44KR49F1 | | | | | | | | | | | | |
| | 200 | 44KR39F1 | | | | | | | | | | | | |
| | 300 | 144KR59F3 | 85 | 3.5 | 13.0 | 45 | 82 | | | | | | | N/A |

Shipping Weights above apply to Threaded Ends Only (except 3" which are Flanged Only)

For Flanged Ends contact factory for complete weight and dimensions

3" STAINLESS STEEL VALVES ARE SUPPLIED WITH FLANGED ENDS ONLY

MAGNATROL VALVE CORPORATION



STAINLESS STEEL SOLENOID VALVES

Dependable • Packless

TYPE "W" FULL PORT - NORMALLY CLOSED 1/2" TO 3" PIPE SIZE

NO DIFFERENTIAL PRESSURE REQUIRED TO OPEN

**MAX. FLUID TEMP.
400° F**
**MAX. STATIC PRESSURE
200 PSI**

OPERATION:

Valve opens when energized and closes when de-energized. When the coil is energized the pilot valve opens, relieving the pressure above the piston, which is then lifted from its seat by the plunger. Upon de-energizing the coil, a spring closes the pilot valve and opens a bleed passageway to permit pressure to build above the piston and seat it.

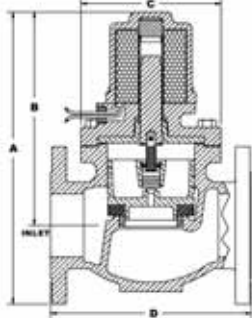
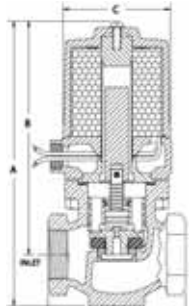

CONSTRUCTION:

- (*Wetted parts - No Copper Bearing Alloys in contact with fluid)
- *Valve Body - 304 Stainless Steel Globe Pattern - NPT ends
(For Flanged Ends see Options page 24)
- *Piston - 303 Stainless Steel
Coil Enclosure - Malleable or Cast Iron, 1/2" NPS conduit conn.
- *Plunger - 430 Stainless Steel
- *Pilot Valve - 303 Stainless Steel
- *Bonnet Tube - 304 Stainless Steel
- *Spring - Inconel
- *Body Seal - Non Asbestos Gasket
- *Orifice Seal - Glass Filled Teflon
- *AC Shading Coil - Silver
- *Stem Pin - Inconel
Coil - Encapsulated Class H, 18" leads

APPLICATION:

To control the flow of STEAM. Steam must be free of sediment. Valve operates from zero to maximum differential pressure indicated in table. Valve must be mounted in horizontal pipe with solenoid enclosure vertical and on top.

**FOR OPTIONS & ACCESSORIES
SEE PAGES 24 & 25**

| Pipe Size Inches | Max. Diff. PSI | Type No. | Watts AC | Amps Hold 120-60 | Amps Inrush 120-60 | Watts DC | Ship Wt. Lbs. | Dimensions In Inches | | | | | | |
|------------------|----------------|----------|----------|------------------|--------------------|----------|---------------|----------------------|--------|-------|-------|------------------|-------|-------|
| | | | | | | | | A | B | C | D | D (Flanged) 150# | | |
| 1/2 | 90 | 14W22 | 25 | 0.4 | 1.2 | 18 | 7 | 7 | 5-7/8 | 2-7/8 | 3-1/4 | 6 | | |
| | 140 | 114W42 | 40 | 0.6 | 1.8 | 28 | | 8 | 6-7/8 | 3-1/2 | | | | |
| | 180 | 129W42 | 65 | 1.2 | 3.6 | 33 | | 10 | 8-1/8 | 7 | | | 3-1/2 | |
| 3/4 | 50 | 14W23 | 25 | 0.4 | 1.3 | 18 | 8 | 7-1/8 | 6 | 2-7/8 | 3-1/2 | 6 | | |
| | 110 | 114W43 | 40 | 0.6 | 2.0 | 28 | | 8 | 6-5/8 | 3-1/4 | | | 4-1/8 | 6-1/2 |
| | 180 | 129W43 | 65 | 1.2 | 3.9 | 33 | | 11 | 8-7/8 | 7-1/2 | | | | |
| 1 | 25 | 16W14 | 25 | 0.4 | 1.5 | 18 | 10 | 8 | 6-5/8 | 3-1/4 | 4-1/8 | 6-1/2 | | |
| | 50 | 116W24 | 40 | 0.6 | 2.3 | 28 | | 8 | 6-5/8 | 3-1/4 | | | | |
| | 90 | 116W44 | 40 | 0.6 | 2.3 | 28 | | 10 | 8-7/8 | 7-1/2 | | | 3-1/2 | |
| | 180 | 131W44 | 65 | 1.2 | 4.2 | 33 | | 13 | 8-7/8 | 7-1/2 | | | 3-1/2 | |
| 1-1/2 | 25 | 35W16 | 45 | 0.8 | 3.2 | 23 | 17 | 10 | 8-1/8 | 4 | 4-7/8 | 6-1/2 | | |
| | 50 | 35W26 | 45 | 0.8 | 3.2 | 23 | | 10 | 8-1/8 | 4 | | | | |
| | 90 | 135W46 | 65 | 1.2 | 4.8 | 33 | | 11 | 9-1/8 | 4-1/2 | | | | |
| | 180 | 141W46 | 85 | 2.0 | 10.0 | 45 | | 21 | 11 | 9-1/8 | | | 4-1/2 | |
| 2 | 25 | 36W17 | 45 | 0.8 | 3.5 | 23 | 27 | 11 | 8-3/4 | 5-3/8 | 6 | 8 | | |
| | 50 | 36W27 | 45 | 0.8 | 3.5 | 23 | | 11 | 8-3/4 | | | | | |
| | 115 | 42W47 | 60 | 1.2 | 7.4 | 35 | | 12 | 9-3/4 | | | | | |
| | 180 | 142W47 | 85 | 2.0 | 11.0 | 45 | | 32 | 12 | | | | 9-3/4 | |
| 3 | 25 | 44W19F1 | 60 | 1.2 | 8.8 | 35 | 68 | 13-3/4 | 10-1/2 | 6-5/8 | N/A | 9-1/2 | | |
| | 50 | 44W29F1 | | | | | | | | | | | | |
| | 100 | 44W49F1 | | | | | | | | | | | | |
| | 150 | 144W49F1 | | | | | | | | | | | | |

Strainers are recommended for use with solenoid valves (See page 19)

When you order please supply the following:

- Pipe Size
 - Valve Type
 - Voltage (AC or DC)
 - Hertz
 - Fluid
 - Fluid Temperature
 - Max. Diff. Pressure
 - Optional Features
- (See pages 24 & 25)

Shipping Weights above apply to Threaded Ends Only (except 3" which are Flanged Only)
For Flanged Ends contact factory for complete weight and dimensions
3" STAINLESS STEEL VALVES ARE SUPPLIED WITH FLANGED ENDS ONLY

STAINLESS STEEL SOLENOID VALVES

Dependable • Packless



TYPE "WR" FULL PORT - NORMALLY OPEN 1/2" TO 3" PIPE SIZE

NO DIFFERENTIAL PRESSURE REQUIRED TO OPEN

OPERATION:

Valve closes when energized and opens when de-energized. When the coil is energized the plunger presses the poppet, closing the pilot orifice, and opens a bleed passageway to permit pressure to build above the piston and seat it. Upon de-energizing the coil, the pilot orifice is opened, relieving the pressure above the piston allowing it to leave its seat. The bottom spring allows the valve to operate at zero pressure drop.

CONSTRUCTION:

- (*Wetted parts - No Copper Bearing Alloys in contact with fluid)
- *Valve Body - 304 Stainless Steel Globe Pattern - NPT ends
(For Flanged Ends see Options page 24)
- *Piston - 303 Stainless Steel
Coil Enclosure - Malleable or Cast Iron, 1/2" NPS conduit conn.
- *Plunger - 430 Stainless Steel
- *Poppet - 303 Stainless Steel
- *Stem - 303 Stainless Steel
- *Bonnet Tube - 304 Stainless Steel
- *Spring - Inconel
- *Body Seal - Non Asbestos Gasket
- *Orifice Seal - Glass Filled Teflon
- *AC Shading Coil - Silver
- *Stem Pin - 304 Stainless Steel
Coil - Encapsulated Class H, 18" leads

APPLICATION:

To control the flow of STEAM. Steam must be free of sediment. Valve operates from zero to maximum differential pressure indicated in table. Valve must be mounted in horizontal pipe with solenoid enclosure vertical and on top.

Strainers are recommended for use with solenoid valves (See page 19)

When you order please supply the following:

- Pipe Size
- Valve Type
- Voltage (AC or DC)
- Hertz
- Fluid
- Fluid Temperature
- Max. Diff. Pressure
- Optional Features

(See pages 24 & 25)

MAX. FLUID TEMP.
400° F
MAX. STATIC PRESSURE
200 PSI



**FOR OPTIONS & ACCESSORIES
SEE PAGES 24 & 25**

| Pipe Size Inches | Max. Diff. PSI | Type No. | Watts AC | Amps Hold 120-60 | Amps Inrush 120-60 | Watts DC | Ship Wt. Lbs. | Dimensions In Inches | | | | | |
|------------------|----------------|-----------|----------|------------------|--------------------|----------|---------------|----------------------|--------|-------|-------|------------------|--------|
| | | | | | | | | A | B | C | D | D (Flanged) 150# | |
| 1/2 | 90 | 14WR22 | 25 | 0.5 | 1.5 | 18 | 7 | 8-1/8 | 7 | 2-7/8 | 3-1/4 | 6 | |
| | 140 | 114WR42 | 40 | 0.8 | 2.4 | 28 | | 9-1/8 | 8 | 3-1/2 | | | |
| | 180 | 129WR42 | 65 | 1.5 | 4.2 | 33 | | 10 | 9-1/8 | 8 | | | 3-1/2 |
| 3/4 | 50 | 14WR23 | 25 | 0.5 | 1.6 | 18 | 8 | 8-1/4 | 7-1/8 | 2-7/8 | 3-1/2 | 6 | |
| | 110 | 114WR43 | 40 | 0.8 | 2.6 | 28 | | 9-1/4 | 8-1/8 | 3-1/2 | | | |
| | 180 | 129WR43 | 65 | 1.5 | 4.3 | 33 | | 12 | 9-1/4 | 8-1/8 | | | 3-1/2 |
| 1 | 25 | 16WR14 | 25 | 0.5 | 1.8 | 18 | 10 | 9-1/8 | 7-3/4 | 3-1/4 | 4-1/8 | 6-1/2 | |
| | 50 | 116WR24 | 40 | 0.8 | 2.9 | 28 | | 10 | 9-1/8 | 7-3/4 | | | 3-1/4 |
| | 90 | 116WR44 | 40 | 0.8 | 2.9 | 28 | | 14 | 10 | 8-5/8 | | | 3-1/2 |
| 1-1/2 | 25 | 35WR16 | 45 | 1.0 | 3.8 | 23 | 18 | 11-3/8 | 9-1/2 | 4 | 4-7/8 | 6-1/2 | |
| | 50 | 35WR26 | 45 | 1.0 | 3.8 | 23 | | 11-3/8 | 9-1/2 | 4 | | | |
| | 90 | 135WR46 | 65 | 1.5 | 5.7 | 33 | | 22 | 11-5/8 | 9-3/4 | | | 4-1/2 |
| 2 | 25 | 36WR17 | 45 | 1.0 | 4.2 | 23 | 27 | 12-3/8 | 10-1/8 | 5-3/8 | 6 | 8 | |
| | 50 | 36WR27 | 45 | 1.0 | 4.2 | 23 | | 12-3/8 | 10-1/8 | | | | |
| | 115 | 42WR47 | 60 | 1.7 | 7.3 | 35 | | 32 | 12-5/8 | | | | 10-3/8 |
| 3 | 25 | 44WR19F1 | 60 | 1.7 | 8.8 | 35 | 69 | 14-3/8 | 11-1/8 | 6-5/8 | N/A | 9-1/2 | |
| | 50 | 44WR29F1 | | | | | | | | | | | |
| | 100 | 44WR49F1 | | | | | | | | | | | |
| | 150 | 144WR49F1 | 85 | 3.5 | 13.0 | 45 | | | | | | | |

Shipping Weights above apply to Threaded Ends Only (except 3" which are Flanged Only)
For Flanged Ends contact factory for complete weight and dimensions
3" STAINLESS STEEL VALVES ARE SUPPLIED WITH FLANGED ENDS ONLY



OPTIONAL FEATURES

For Dependable • Packless Solenoid Valves

See Individual Options For Availability For Use With Specific Valve Types

BOTTOM MOUNTED OPTIONS Note: Only One Bottom Mount Option Can Be Installed On Each Valve

MANUAL OVERRIDE

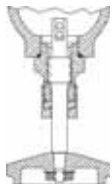

(Normally Closed valves only)
(Designated by Prefix "MO")
Enables manual opening of solenoid valve during power failure or to override automatic controls.

LEVER

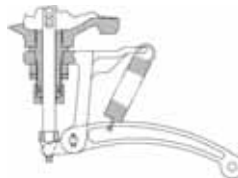

(Normally Closed valves only)
(Designated by Prefix "LV")
Enables rapid opening of solenoid valve. Can be chain operated for use at inaccessible locations.

DASHPOT



(Designated by Prefix "DP")
Furnished for clean liquids to reduce water hammer effect sometimes encountered in long pipe runs by slowing valve closing.

FLOW CONTROL

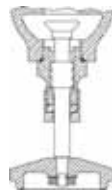

(Normally Closed, NR & MR valves, only)
(Designated by Prefix "FC")
Provides a manual method of reducing or throttling the flow.

MOUNTING STUD



(Designated by Prefix "MS")
3/8"-16 thread can be furnished in bottom of body to facilitate mounting on bracket. (Not available on 2", 2-1/2" and 3")

DRAIN



(Normally Closed, NR & MR valves, only)
(Designated by Prefix "DR") - 1/4" NPT plug supplied in bottom of valve to facilitate draining of liquid from valve body.

OTHER OPTIONS

PILOT TAP



(Designated by Prefix "PT")
Type D, G & GR Valves can be furnished with 1/8" tapped hole for pilot connection or pressure gauge.

DIN CONNECTOR

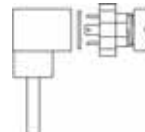

(Designated by Suffix "DN")
Provides 3 prong connector for easy power connect / disconnect.
Not available for Explosion-Proof.

"HUM FREE": (No AC Hum/Buzz)

(Designated by Suffix "HF") - The "HUM FREE" option eliminates the "AC hum" associated with AC operated solenoid valves. Enables valves to be used where an AC hum would not be acceptable and AC is the only power source available. IE: Hospitals, labs, schools (class rooms), homes, office environments etc. & when 24 vac is required for 40 series valves.

Leak / Dead Tight:

(Normally Closed valves only)
(Designated by Suffix "LT") - The Leak / Dead Tight Option offers 'soft' resilient seating or 'gapless' seal for low pressure applications 50 PSI or less. Consult Factory for Max. Diff. Pressure and Valve Type availability.

Flanged Ends for SS Valves:

(Designated by Suffix "F1" for 150 lb or "F3" for 300 lb Flanges) Available on stainless steel valves. (Flanged ends for bronze valves available through our Clark-Cooper Division, see bottom of page 3).

Explosion-Proof and Watertight Solenoids:

(Designated by Prefix "F") - are Explosion-proof and NEMA 4, 7C & D, 9E, F & G suitable for use in hazardous locations requiring Class I, Groups C & D & Class II Groups E, F, and G equipment.

NEMA 4X:

(Designated by Prefix "F" AND Suffix "ZP") - are suitable for use in locations requiring a NEMA 4X designation. "ZP" (Zinc Plating) replaces the standard paint used on the Coil housing (cup and base). The additional corrosion protection satisfies NEMA 4X requirements. Internal construction, pressure ratings, power consumption, and external dimensions are the same as for standard valves.

Nickel Plating:

(Designated by Suffix "NP") - Plating is 0.0005" Thick Meets Mil Spec. C26074

Universal Mount Valves For Mounting In Vertical Pipe Runs
(See Magnatrol Universal Mount Catalog 3006-UM)

POSITION INDICATORS

For Normally Closed Solenoid Valves



FEATURES:

- Packless non-wetted enclosed operation
- Colored magnet shows valve-open position
- Clear high-strength polycarbonate housings
- Heavy-duty Normally Open Reed Switch (PS)
- Wide operating temperature range
- Teflon Housing for temperatures up to 400°F & Cryogenics **
- Explosion-Proof Housing available for hazardous areas **

“PD” (POSITION DISPLAY) - VISUAL INDICATION ONLY

CONSTRUCTION:

- Housing: Clear High-Strength Polycarbonate

APPLICATION:

- Visual Indication that valve is Open / Closed

OPERATION:

When the valve is in the closed position, a ferromagnetic “target” attached to the valve’s piston, lifts a green colored magnet into the adapter hiding it from view. When the valve is energized, (open position), the magnet drops down to a visible position.

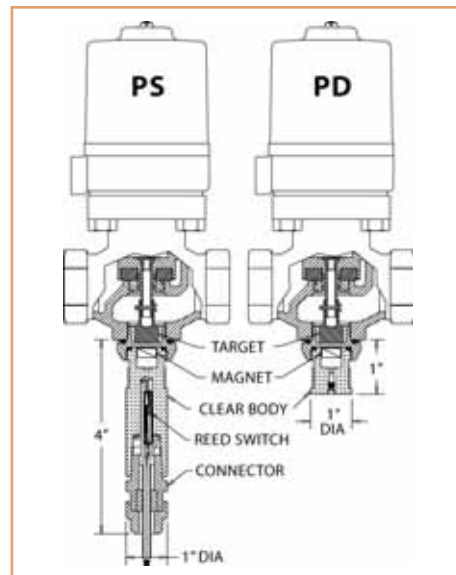

“PS” (POSITION SWITCH) - VISUAL INDICATION WITH SWITCH**

CONSTRUCTION:

- Housing: Clear High-Strength Polycarbonate**

APPLICATION:

- Visual Indication that valve is Open/Closed and Contact Closure (Switch)**

** (See alternate housing(s) below for High Temperature, Cryogenic and Explosion-Proof applications)

OPERATION:

When the valve is in the closed position, a ferromagnetic “target” attached to the valve’s piston, lifts a green colored magnet into the adapter hiding it from view. (The reed switch is in its normally open contact position). When the valve is energized, (open position), the magnet drops down to a visible position and closes the magnetically operated reed switch contacts. The reed switch is capable of switching both AC and DC, permitting direct control over a wide range, from low-level load to electromagnetic power load. It has a rated operational current 240 VAC 0.5 A, 115 VDC 0.3A and a minimum operational power of 24V 1mA. The switch is wired with 22 AWG conductors exiting through a liquid tight strain relief connector.

Position Indicators for Normally Closed Valve Only* Available on Type A, S, L, K, W & G Valves

NOTE: ONLY ONE BOTTOM MOUNTED OPTION CAN BE INSTALLED ON EACH VALVE*

To indicate Option when Ordering:
Use Prefix “PD” for Position Display
Use Prefix “PS” for Position Switch

Example PS18A44 indicates a Position Switch mounted on a type 18A44 valve.

***For multiple switches and where a switch and a bottom mounted option are required, contact our Clark Cooper Div. (See bottom of Page 3).**

**** ENCLOSURES & TEMPERATURE RATINGS**

| Indicator Housings | Option | Application | | Fluid Temperatures | Visual Indication |
|-----------------------------------|--------|-------------|-------------|------------------------------------|-------------------|
| | | Expl. Proof | NEMA 4 & 4X | | |
| Clear High-Strength Polycarbonate | PD | Yes | Yes | -40°F To 280°F (137°C) | Yes |
| | PS | No | | | |
| Teflon Housing | PS | No | Yes | Up To 400°F (204°C) and Cryogenics | No |
| Explosion Proof Housing | PS | Yes | Yes | Up To 400°F (204°C) and Cryogenics | No |

MAGNATROL VALVE CORPORATION



REQUEST A QUOTE

Fill In The Information Below

If you have any questions or wish to request a quote:

Phone: 973-427-4341 • Fax: 973-427-7611

E-Mail: info@magnatrol.com

We appreciate the opportunity to quote on your requirements.

For immediate quote – Fill in the information below and CALL: 973-427-4341

For same day quote – Fill in the information below and FAX: 973-427-7611

For quote within 24 hrs – Go online to www.magnatrol.com, and go to Quick Quote.

YOUR COMPANY DATA

Company Name: _____ **Phone:** _____

Contact (Your Name): _____ **Fax:** _____

Your RFQ Reference (If Any): _____

Type of Business: OEM Re-Seller Consumer/End User

E-Mail: _____

VALVE DATA

Desired Delivery: _____

Your Reference (Optional): _____

Quantity: _____

Valve Construction Material: Bronze or Stainless Steel

Pipe Size: (1/4" thru 3"): _____

Normally: **Closed** (Energize To Open) or **Open** (Energize To Close)

Voltage: **AC:** _____ Volts/_____ Hz or **DC:** _____ Volts

Maximum Differential Pressure: _____ PSI

Fluid: _____

Maximum Fluid Temperature: _____ °F

Optional Feature: (See Optional Feature Details On Pages 24 & 25)

Choose One (1) Of The Following Per Valve: MO LV DP FC MS DR PD PS

Additional Options: HF LT NP PT (Can be combined with one (1) of the above Optional Features) DN ZP

Enclosure Options: General Purpose Explosion Proof NEMA 4 NEMA 4X
(For Solenoid Housing) (Standard - NEMA 12) (Prefix "F") (Prefix "F") (Prefix "F" & Suffix "ZP")

Comments: _____

Quantity Discounts: Consult Factory

Delivery: Most orders ship in 7-10 days. Small emergency orders can be shipped in 1-2 days.

MAGNATROL VALVE CORPORATION

ORDERING GUIDELINES

Magnatrol Solenoid Valves



If you have any questions or wish to request a quote:
Phone: 973-427-4341 • Fax: 973-427-7611
E-Mail: info@magnatrol.com

**For Help In Choosing The Correct Valve For Your Application:
 REFER TO THE VALVE SELECTION CHART ON PAGE 3**

MAGNATROL VALVE TYPE NUMBERS PREFIX AND SUFFIX BREAKDOWN

*For Additional Information On Options
 See Optional Features Pages 24 & 25*

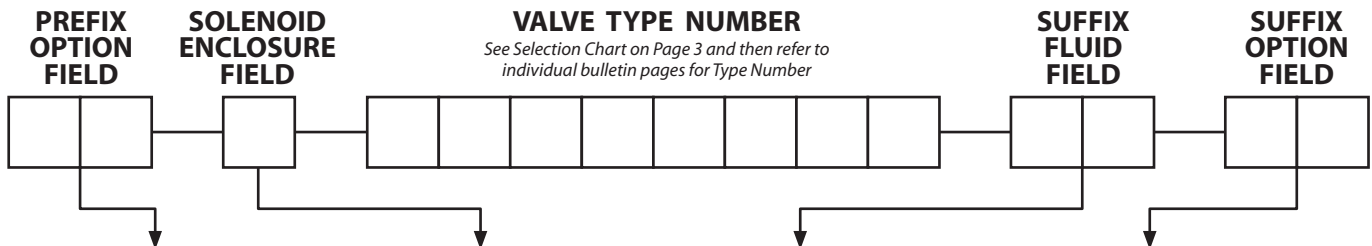

Prefix Letters for Options:
Choose One

DP Dashpot (Consult factory for valve type availability)
DR Drain Plug **
FC Flow Control **
LV Lever *
MO Manual Override
MS Mounting Stud
PD Position Display *
PS Position Switch *
PT Pilot Tap ***

Prefix Letters for Solenoid Enclosures:

(Blank) = NEMA 12
F = Explosion Proof & NEMA 4
F with ZP Suffix = NEMA 4X

Suffix Letters for Fluids: †

A Air
B Brine
C Gritty Coolant
G Gas
H Hot Water
J Jet Fuel or Kerosene
K Gasoline or Naphtha
L Alcohol
O Oil
P Soluble Oil or Coolant
R Freon/Refrigerant
V Sandy Well Water
W Cold Water
Y Gaseous Oxygen
YZ Liquid Oxygen
Z Cryogenics

Suffix Letters for Options:

DN Din Connector
E Extra Fast Closing
HF Hum Free
HT High Temperature Coil
LT Leak/Dead Tight (Soft Seat Pilot)
NP Nickel Plated (.005 Thickness) Meets Mil Spec C26074
X Sealant
ZP Zink Plated Cup & Base

For Stainless Valves: ††

F1 150# Flanged Ends
F3 300# Flanged Ends

* Normally Closed Only
 ** Normally Closed and NR & MR Valves/ FC not available on "G" valve type
 *** Pilot Tap: Can be used along with any other option. Available for Type D, G and GR only.

† If your fluid is not listed leave blank & advise Magnatrol of fluid



VALVE DISC AND GASKET CHANGES:

Valve Disc and Gasket are sometimes changed/substituted for better performance with a given fluid. The change is represented by the insertion of a letter after the Valve Type letter(s). The inserted letter represents the substituted Disc/Gasket material. See examples below:

Examples:

V - Viton Disc (i.e. Type 18A44 with Viton Seals becomes 18AV44)
 T - Teflon Disc (i.e. Type 18A44 with Teflon Seals becomes 18AT44)
 B - Buna-N Disc (i.e. Type 16L44 with Buna-N Seals becomes 16LB44)

NOTE: Refer to individual bulletins for Valve Type's standard Disc and Gasket materials.

NOTE

Magnatrol Valve Type Numbers DO NOT include Voltage information.

VOLTAGE (AC Volts and Hz or DC Volts) MUST BE SPECIFIED when requesting a quote or placing and order.



TERMS & CONDITIONS OF SALE CONTACT INFORMATION

Solenoid valve questions can be answered quickly and accurately over the phone:

Phone: 973-427-4341 • Fax: 973-427-7611

TERMS & CONDITIONS OF SALE

1. **Catalog:** This catalog supersedes all previous issues.
 2. **Quotations:** Quotations are made for acceptance within 60 days and are subject to change or withdrawal without notice.
 3. **Prices and Discounts:** All prices and discounts are in accordance with the prices and discounts established by Magnatrol and are subject to change without notice.
 4. **Terms:** Net 30 days, subject to establishment of credit.
 5. **Shipments:** All shipments are F.O.B. factory, Hawthorne, New Jersey. Our responsibility ends with delivery of merchandise to the transportation company and issuance to us of formal shipping receipt.
 6. **Minimum Billing:** Minimum billing charge is \$50.00 net.
 7. **Cancellations:** Orders are subject to cancellation only with our consent.
 8. **Shipping Date:** There shall be no liability for default or delay in shipping. All orders, contracts, and agreements are made subject to delays contingent upon accidents, strikes, embargoes or other causes beyond our control.
 9. **Design and Materials:** All materials and designs are subject to change without notice.
 10. **Weights and Dimensions:** Weights and dimensions listed in this catalog are as close to actual as is practicable but are not guaranteed and are subject to change without notice.
 11. **Errors:** All clerical errors are subject to correction.
 12. **Returns for Repair:** Valves returned for repair must be shipped prepaid and accompanied by a detailed report regarding service application, installation and nature of trouble or malfunction.
 13. **Returns for Credit:** Returns for credit will be accepted only with our consent. Credit will be subject to restocking charge and any additional expenses incurred in restoring valves to salable condition. Credit will be issued only to original purchaser.
 14. **Taxes:** Any manufacturer's excise tax, use tax, sales tax or tax or duty of any nature shall be paid by the buyer. In the event that the seller is required to pay any such taxes or duties, the buyer shall reimburse seller therefore. The buyer may provide seller with an exemption certificate or other documents acceptable to taxing or customs authorities at the time an order is placed.
 15. **Guarantee:** MAGNATROL valves are guaranteed to be free from any defects in material and workmanship for one year or 500,000 cycles, whichever comes first. Our guarantee solely conveys the right to repair or replace free of charge, any defective valves, or parts, thereof, returned to us transportation charges prepaid, within one year after date of original shipment from factory.
- This guarantee shall not apply if the valve has been:**
- Improperly Installed
 - Used for other than intended service
 - Repaired without authorization



Check individual bulletins for listed valves

MAGNATROL CONTACT INFORMATION

Sales, Service, Tech Support: Phone: 973-427-4341
 Fax: 973-427-7611
 Email: info@magnatrol.com
 techsupport@magnatrol.com

Mailing Address: PO Box 17
 Hawthorne, NJ 07507

Shipping Address: 21 Horton Avenue
 Hawthorne, NJ 07506

Administrative: 67 Fifth Avenue
 Hawthorne, NJ 07506

