



**Instruction Manual
and
Parts List
for
Series 3E
Rotor Sizes 187 and 200**



WARNING

This Instruction Manual and General Instructions Manual, CA-1, should be read thoroughly prior to pump installation, operation or maintenance.

SRM00019 Rev. 2 February, 1997



READ THIS ENTIRE PAGE BEFORE PROCEEDING

FOR THE SAFETY OF PERSONNEL AND TO PREVENT DAMAGE TO THE EQUIPMENT, THE FOLLOWING NOMENCLATURE HAS BEEN USED IN THIS MANUAL:

	DANGER	
Failure to observe the precautions noted in this box can result in severe bodily injury or loss of life.		

	WARNING	
Failure to observe the precautions noted in this box can cause injury to personnel by accidental contact with the equipment or liquids. Protection should be provided by the user to prevent accidental contact.		

	CAUTION		ATTENTION
Failure to observe the precautions noted in this box can cause damage or failure of the equipment.			

Non compliance of safety instructions identified by the following symbol could affect safety for persons:	Safety instructions where electrical safety is involved are identified by:	Safety instructions which shall be considered for reasons of safe operation of the pump and/or protection of the pump itself are marked by the sign:
		ATTENTION

ATTENTION
<i>If operation of this pump is critical to your business, we strongly recommend you keep a spare pump or major repair kit in stock at all times. As a minimum, a minor repair kit (o-rings, gaskets, shaft seal and bearings) should be kept in stock so pump refurbishment after internal inspection can be accomplished.</i>

GENERAL INSTRUCTIONS

NOTE: Individual contracts may have specific provisions that vary from this manual. Should any questions arise which may not be answered by these instructions, refer to General Instructions Manual, CA-1, provided with your order. For further detailed information and technical assistance please refer to Imo Pump, Technical Service Department at (704) 289-6511.

This manual cannot possibly cover every situation connected with installation, operation, inspection and maintenance of equipment supplied. Every effort was made to prepare text of manual so that engineering and design data is transformed into most easily understood wording. Imo Pump must assume personnel assigned to operate and maintain supplied equipment and apply this instruction manual have sufficient technical knowledge and are experienced to apply sound safety and operational practices which may not be otherwise covered by this manual.

In applications where equipment furnished by Imo Pump is to be integrated with a process or other machinery, these instructions should be thoroughly reviewed to determine proper integration of the equipment into overall plant operational procedures.

**TABLE 1
3E SERIES PUMP MODELS**

ROTOR SIZES (1) - 187, 187D, 200 and 200D			
Pump Model (1)	Fig. No.	Pump Model (1)	Fig. No.
C3EBC	6	C3EHFS	5
C3EBCS	6	C3EHT	6
C3EBCX	5	C3EHTFS	6
C3EBF	4	C3EIC	4
C3EBFS	5	C3EICS	4
C3EBT	6	C3ENC	5
C3EBTCS	5	C3EX	4
C3EBTFS	6	C3EXFS	6
C3EHC	6	C3EXS	4
C3EHCS	6	C3EXTFS	6
C3EHF	5		

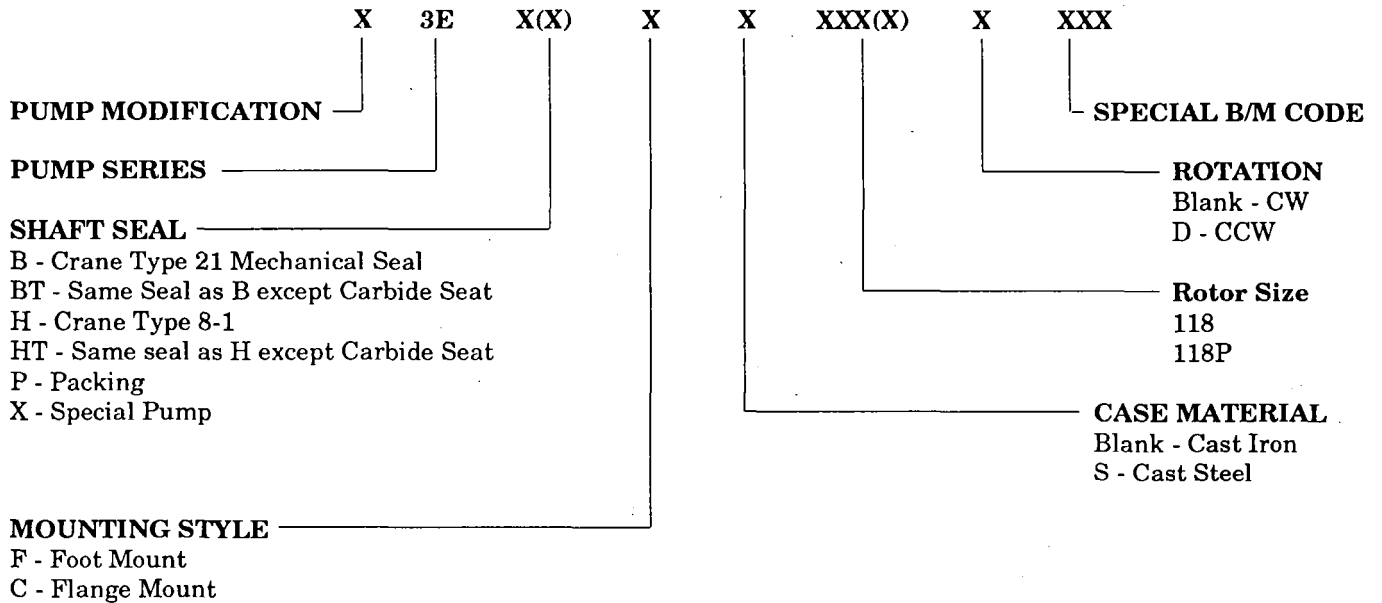

FIGURE 1. Definition of Model Desingators.

STRUCTURAL LIMITS

Operating conditions, such as speed, fluid viscosity, inlet pressure, discharge pressure, temperature, filtration, duty cycle, mounting, drive type, etc. are interrelated. Due to these variable conditions, the specific application may be different from that of the structural limitations. This equipment must not be operated without verification that operating requirements are within published capabilities as shown in the appropriate pump data (available from local IMO Pump Division offices and representatives listed in CA-1 manual).

Under no circumstances are the following structural limitations to be exceeded.

DISCHARGE PRESSURE: 150 PSIG (Maximum)

MAXIMUM SPEED: Contact the IMP Pump Division for Rating Tables. For No. 6 fuel oil, crude oil and fluids known to contain fine abrasives, pump speed should not exceed 1800 RPM.

VISCOSITY: 2.0 cst (33 SSU) Minimum
3000 SSU maximum for type B shaft seal. No maximum for other versions.
The type B seal is not recommended for use when using No. 6 fuel oil regardless of specified operating viscosity range.

TEMPERATURE: 0 degrees F to 180 degrees F for types C3EB and C3EI
0 degrees F to 250 degrees F for type C3EH

FILTRATION: Light fluids – 60 mesh
Heavy fluids – 1/16 to 1/8 inch

SUCTION: 25 PSI (Maximum)

MOUNTING: May be mounted in any attitude

DRIVE: Direct only

ROTOR SHAFT SEALS

FIGURE 4. Pumps identified in Figure 4 are integral mounted design and are not equipped with a seal.

FIGURES 5 and 6. Fluid sealing along the power rotor shaft is accomplished by the use of a spring loaded mechanical seal.

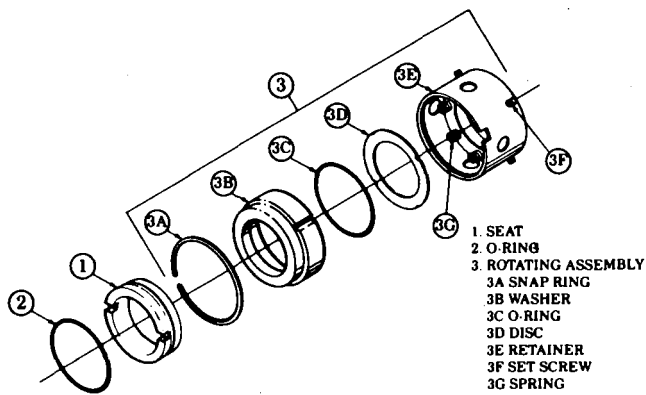

FIGURE 2. Crane 8-1 Mechanical Seal

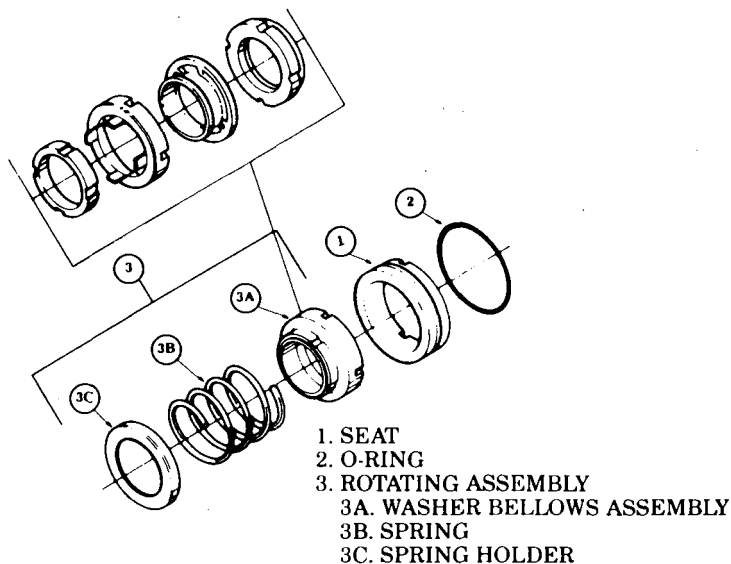

FIGURE 3. Crane Type 21 Mechanical Seal

MAINTENANCE

GENERAL. To perform maintenance on the Series C3E pumps, the following initial conditions shall be completed prior to the maintenance action: Close the inlet and outlet valves and tag "Out of Service." De-energize pump drive motor controller and tag "Out of Service." Vent all pressure from pump housing. Remove pump from driver and remove coupling from pump. Remove coupling key (013).

SERVICING SEALS AND BEARINGS (Figures 5 and 6): Complete General steps, then remove the mechanical seal (016) by first removing bearing retainer bolts (006) and retainer (012). Rotate the power rotor in the direction opposite its normal rotational direction and simultaneously pull the assembled power rotor (007) from the pump. Removal of power rotor (007) includes removal of retaining ring (015), ball bearing (011), spacer (093), O-ring (096) and mechanical seal (016).

Remove retaining ring (015) nearest power rotor

key slot. Press bearing (011) off power rotor (007) by supporting spacer sub-assembly and pressing the power rotor from the bearing. Remove the remaining retaining ring (015) and slide spacer (093) with O-ring (096) and mechanical seal (016) from power rotor shaft. **NOTE:** To remove Crane 8-1 or metal bellows seal, first loosen setscrews (3F, Figure 2) before sliding mechanical seal (016) rotating assembly from shaft.

Assemble pump with a new mechanical seal (016), ball bearing (015), and O-ring (096). Clean power rotor (007) and coat power rotor with SAE-30 oil. Install mechanical seal (016) on power rotor shaft as follows:

Crane 8-1 or metal bellows (Refer to Figure 2 or 2A): Slide assembled rotating parts (3) on power rotor (007) shaft with retainer (3E) next to power rotor sleeve. Tighten setscrews (3F). Coat seat (1) and O-ring (2) with SAE-30 oil and install O-ring (2) on seat (1). Install assembled seat (1 and 2) in spacer (093), ensuring that spring pin engages slot in seat (1).

Crane Type 21 (Refer to Figure 3): Slide rotating assembly (3) on power rotor (007) shaft with spring holder (3C) next to power rotor sleeve. Coat seat (1) and O-ring (2) with SAE-30 oil and install O-ring (2) on seat (1). Install assembled seat (1 and 2) in spacer (093), ensuring that spring pin engages slot in seat (1).

1. SEAT
2. O-RING
3. ROTATING ASSEMBLY
 - 3A. BELLOWS ASSEMBLY
 - 3B. BELLOWS ASSEMBLY O-RING
 - 3F. SETSCREW

FIGURE 2A. Standard Metal Bellows Type Mechanical Seal

Coat O-ring groove of spacer (093) with SAE-30 oil and install new O-ring (096) in groove of spacer (093). Install spacer (093) on power rotor (007) shaft. Install retaining ring (015) in groove of power rotor (007) farthest from key (013) slot. Support power rotor (007) and press ball bearing (011) on power rotor (007), pressing only on inner race of bearing (011). Install retaining ring (015) in groove of power rotor (007). Install assembled power rotor (007) in pump, centering each part as it enters pump. Rotate power rotor as it enters pump to mesh power rotor with idler rotors. Install retainer (012) on cover (004) and install bolts (006). Torque bolts (006) to a torque value of 40 lbs. inch (+/- 5 lbs. inch). Install pump and align pump with driver.

PUMP DISASSEMBLY

FIGURE 4. Prior to pump disassembly, perform General steps described on page 2.

Figure 4: On pumps equipped with adapter (028), adapter (028) may be removed by removing bolts (037).

NOTE: Loctite 510 gasket eliminator is installed between adapter (028) and cover (004). Adapter should be removed only if adapter (028) or cover (004) must be replaced.

Continue disassembly of Figure 4 pump by removing bolts (003) to remove inlet cover (002) from outlet cover (004). Remove assembled housing (001) and O-ring (026). Removal of housing includes removal of rotors and thrust assembly. Remove bolts (034), washers (035), spacer (033) and thrust plate (032) from housing (001). Slide power rotor (007) and idlers (008) from housing (001) bores.

PUMP ASSEMBLY

GENERAL: Inspect, clean and coat all internal and rotating parts with SAE-30 lubricating oil prior to assembly. Rotate power rotor (007) frequently during assembly to ensure freedom of rotation. The IMO Pump Division recommends replacement of O-rings, mechanical seal, ball bearing and packing (as applicable to pump type) when these parts have been disturbed from their original installed position.

FIGURE 4. With all parts clean and coated with SAE-30 lubricating oil, slide washers (035), thrust plate (032) and spacers (033) on bolts (034). Install assembled bolts (034) in housing (001). Torque bolts (034) to a torque value of 20 lbs. ft. (+/- 2 lbs. ft.). Install idler rotors (008) and power rotor (007) in housing (001). Install assembled housing in outlet cover (004), centering power rotor (007) as it enters cover bushing. Install O-ring (026) in groove of cover (004). Install inlet cover (002) on outlet cover (004) using bolts (003). Torque bolts (003) to a torque value of 45 lbs. ft. (+/- 5 lbs. ft.). Complete assembly of Figure 4 pump as follows:

Figure 4. Adapter plate (028) used on pump types C3EXS-187-500 and C3EXC-501 is installed by placing Loctite 510 gasket eliminator between outlet cover (004) and adapter plate (028) and installing bolts (037). Torque bolts (037) to a torque value of 45 lbs. ft. (+/- 5 lbs. ft.).

FIGURES 5 and 6. With all parts clean and coated with SAE-30 lubricating oil, slide washers (035), thrust plate (032) and spacer (033) on bolts (034). Install assembled bolts (034) in housing (001). Torque bolts (034) to a torque value of 20 lbs. ft. (+/- 2 lbs. ft.).

Install idler rotors (008) in housing (001) and install assembled housing in outlet cover (004). Install new O-ring (026) in groove of cover (004). Install inlet cover (002) on outlet cover (004) using bolts (003). Torque bolts (003) to a torque value of 45 lbs ft. (+/- 5 lbs. ft.).

Complete assembly of Figures 5 and 6 pumps by following procedures outlined for appropriate mechanical seal in Servicing Seals and Bearings, page 2.

TABLE 2
LIST OF MATERIAL - FIGURES 4 THRU 6

Part No.	Part Description	Part No.	Part Description
001 XX	Housing Subassembly	019	Nameplate (6)
002	Inlet Cover	020	Nameplate (6)
003	Bolt (1)	021	Drive Screw (1)
004	Cover Subassembly (2) (3)	026 X	O-ring
006	Bolt (1) (4)	028	Adapter (7)
007 XX	Power Rotor Subassembly	032 XX	Thrust Plate
008 XX	Idler Rotor (5)	033	Spacer (5)
011 X	Ball Bearing (4)	034	Bolt (5)
012	Retainer (4)	035	Lockwasher (5)
013	Key	037	Bolt (1) (7)
015	Retaining Ring (4) (5)	093	Spacer Subassembly (4)
016 X	Seal (4)	096	O-ring

All quantities are one (1) except as noted.

X denotes Minor Repair Kit items.

XX denotes Major Repair Kit items. Items marked X also included in Major Repair Kit.

- (1) Quantity 4
- (2) Figure 5 Part Description - Foot Cover
- (3) Figure 6 Part Description - Flange Cover
- (4) Figure 5 and 6 only
- (5) Quantity 2
- (6) Steel pumps only
- (7) Pump types C3EX-187-500 and C3EX-187-501 only

NOTE: The IMO Pump Division recommends that repair parts be ordered by Minor or Major Repair Kit. When ordering kit, identify Minor or Major Repair Kit, pump model and serial number.

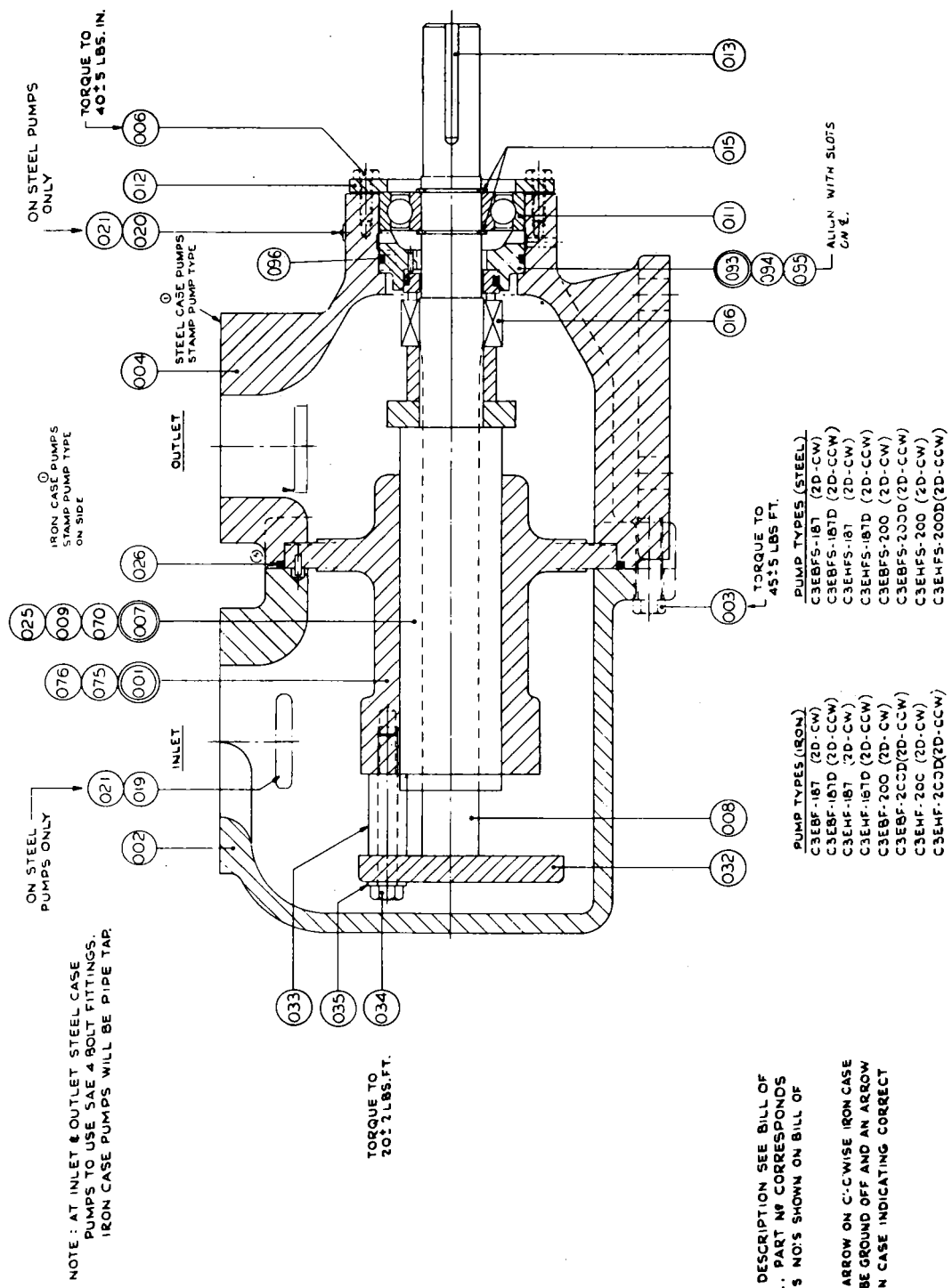

NOTE: AT INLET & OUTLET STEEL CASE PUMPS TO USE SAE 4 BOLT FITTINGS. IRON CASE PUMPS WILL BE PIPE TAP.

1. FOR PART DESCRIPTION SEE BILL OF MATERIAL. PART NO CORRESPONDS WITH IDP'S NO'S SHOWN ON BILL OF MATERIAL.

2. ROTATION ARROW ON C.C.WISE IRON CASE PUMPS TO BE GROUND OFF AND AN ARROW STAMPED ON CASE INDICATING CORRECT ROTATION.

- | | |
|---------------------|----------------------|
| PUMP TYPES (IRON) | PUMP TYPES (STEEL) |
| C3EBF-18T (2D-CW) | C3EBFS-18T (2D-CW) |
| C3EBF-18TD (2D-CCW) | C3EBFS-18TD (2D-CCW) |
| C3EHF-18T (2D-CW) | C3EHFS-18T (2D-CW) |
| C3EHF-18TD (2D-CCW) | C3EHFS-18TD (2D-CCW) |
| C3EBF-200 (2D-CW) | C3EBFS-200 (2D-CW) |
| C3EBF-200D (2D-CCW) | C3EBFS-200D (2D-CCW) |
| C3EHF-20C (2D-CW) | C3EHFS-20C (2D-CW) |
| C3EHF-20CD (2D-CCW) | C3EHFS-20CD (2D-CCW) |

EST. WEIGHT - LBS
 IRON CASE 24.5
 STEEL CASE 91.0

FIGURE 5. Assembly Drawing SD-5570

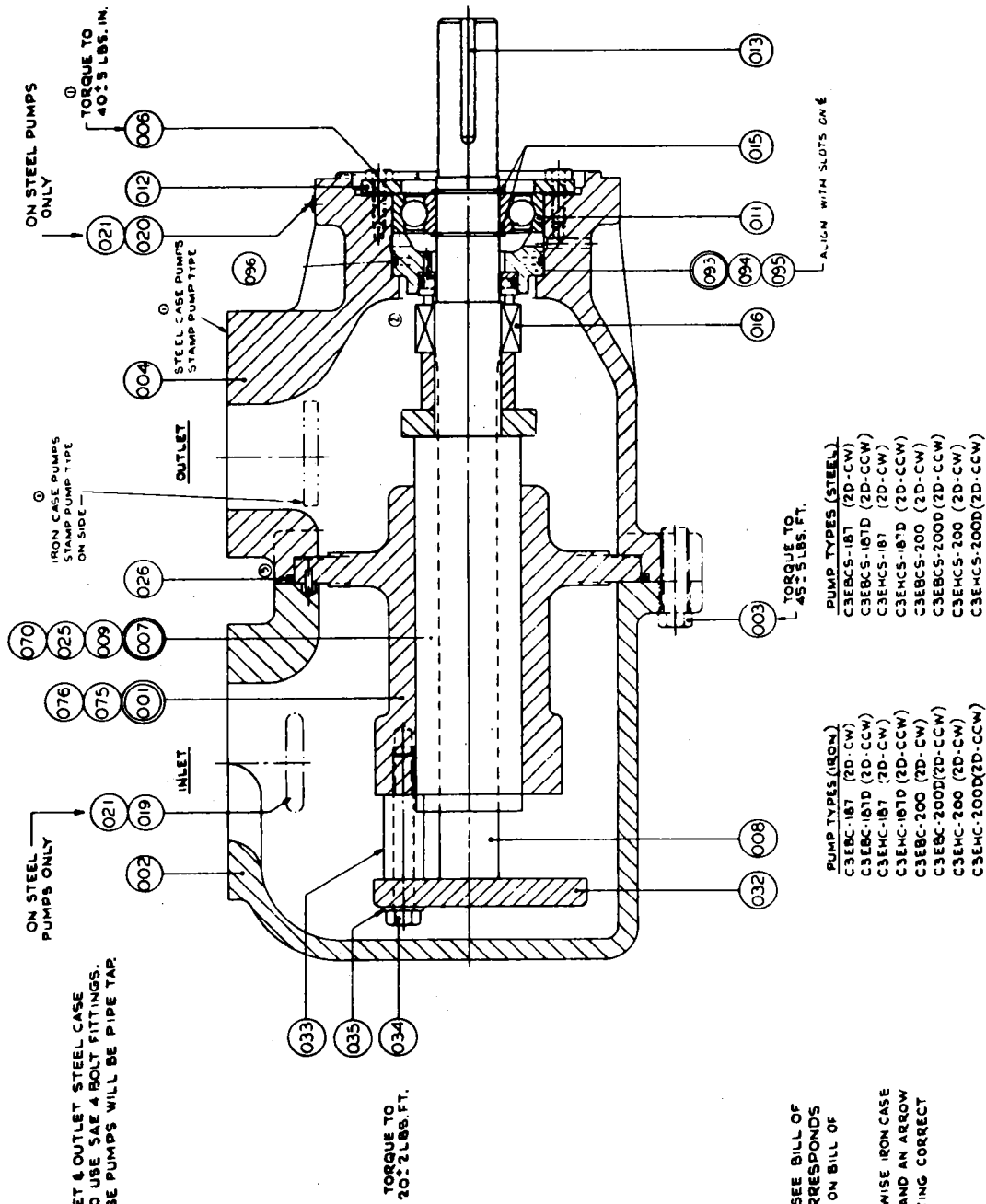

NOTE: AT INLET & OUTLET STEEL CASE PUMPS TO USE SAZ 4 BOLT FITTINGS. IRON CASE PUMPS WILL BE PIPE TAP.

1. FOR PART DESCRIPTION SEE BILL OF MATERIAL. PART NO CORRESPONDS WITH IDP'S NO'S SHOWN ON BILL OF MATERIAL.

2. ROTATION ARROW ON C/C WISE IRON CASE PUMPS TO BE GROUND OFF AND AN ARROW STAMPED ON CASE INDICATING CORRECT ROTATION.

EST. WEIGHT - LBS
IRON CASE 83.5
STEEL CASE 97.0

FIGURE 6. Assembly Drawing SD-5571

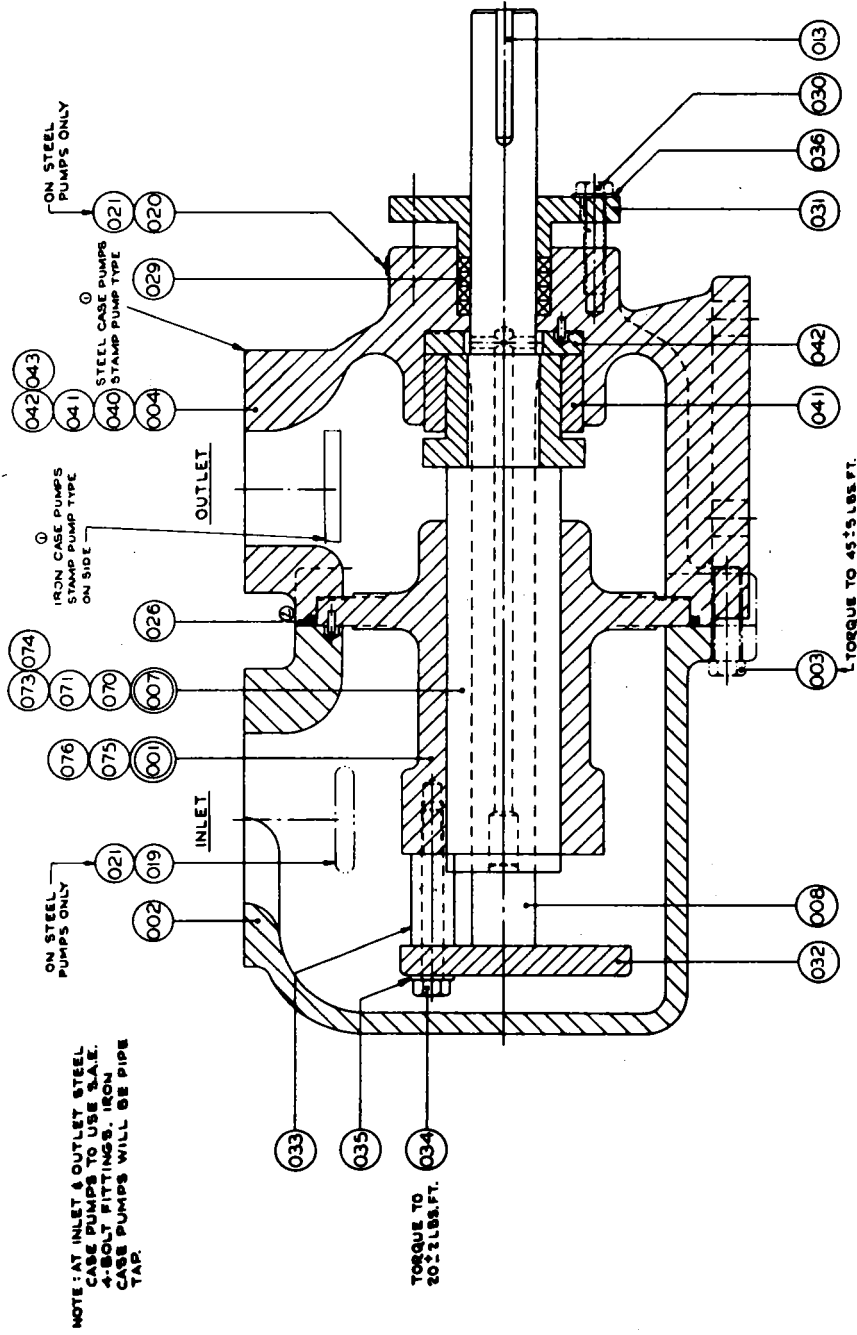

1. FOR PART DESCRIPTION SEE BILL OF MATERIAL. PART NO CORRESPONDS WITH IDP'S NO'S SHOWN ON BILL OF MATERIAL.

- PUMP TYPES (IRON)
- C3EPF-187 (2D-CW)
- C3EPF-200 (2D-CW)
- PUMP TYPES (STEEL)
- C3EPFS-187 (2D-CW)
- C3EPFS-200 (2D-CW)

EST. WEIGHT - LBS
 IRON CASE 92.5
 STEEL CASE 100.5

FIGURE 7. Assembly Drawing SD-5572



ALLWEILER



HOUTTUIN



IMO PUMP



WARREN



A MEMBER OF THE
COLFAX PUMP GROUP

Imo Pump

1710 Airport Road
PO Box 5020
Monroe, NC USA
28111.5020

tel 704.289.6511

fax 704.289.9273

email Imo.Pump@ColfaxCorp.com

web WWW.IMO-PUMP.COM

