

# Series 1500 Screwed & Flanged Safety Relief Valves

- Manufactured in accordance with ASME Code Section VIII
- NBBI capacity certified for air/gas, liquid & steam
- Excellent flow capacities
- NACE and severe service options
- Temperature Range  $-450^{\circ}\text{F}$  to  $1000^{\circ}\text{F}$

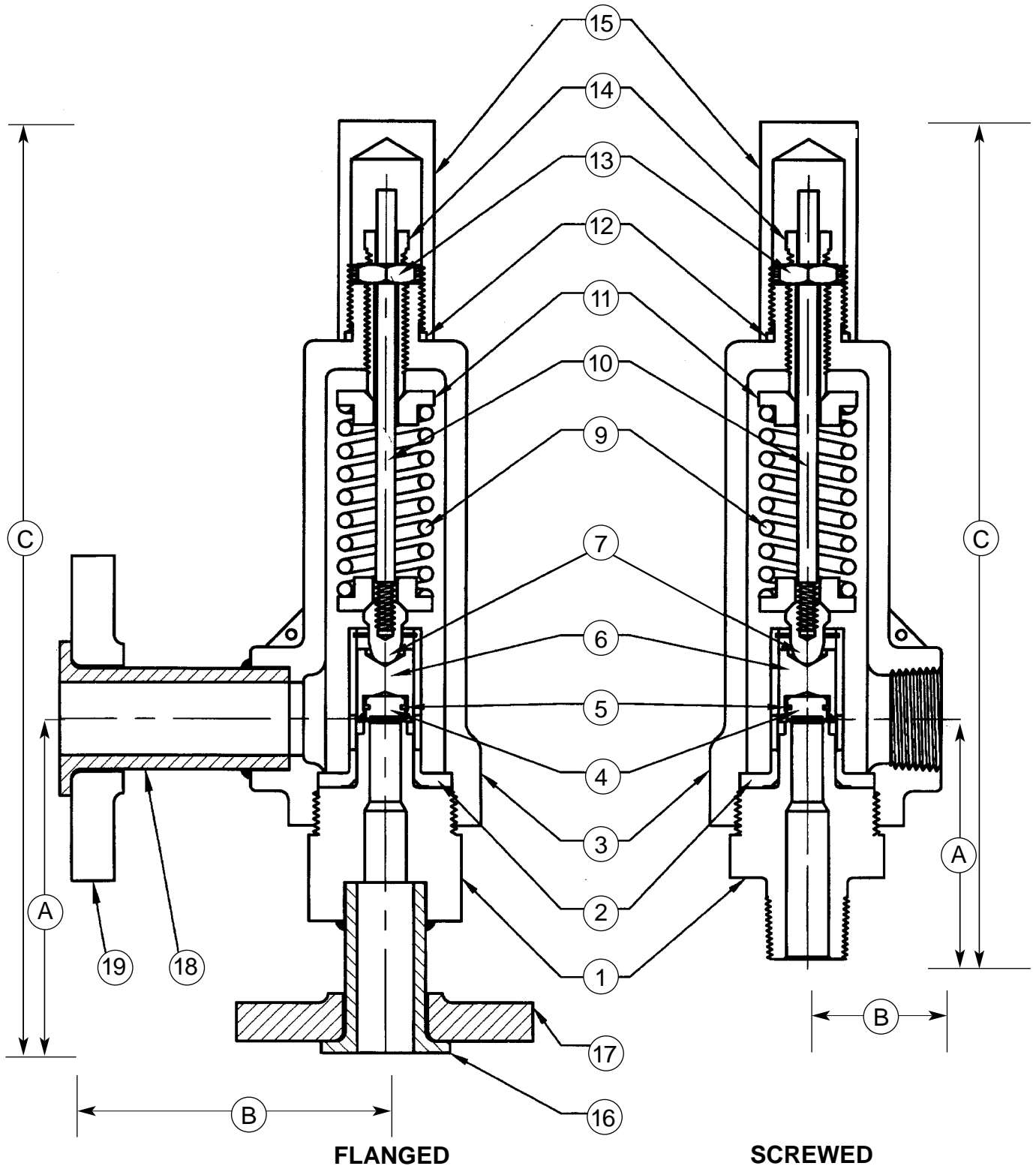





See pages F6 and F7 for material selection

# Product Nomenclature, Flanged

**15**      **D**      **1**      **A**      **1**  
**SERIES**      **ORIFICE**      **INLET/OUTLET**      **FLANGE RATING**      **1- RFxRF**  
**2- RJTxRF**

API Orifice Area (sq. in.) D 0.110 E 0.196 F 0.307 G 0.503	DIMENSIONS										Weight Lb. (approx.)
	Inlet	Outlet	FLANGE	Inlet	Outlet	pset (max psi)	Outlet CL to Inlet Fa A	Inlet CL to Outlet F B	Overall Height C		
D 1 1/2"	1"	A	150	150	285	6	4	13 3/4	12		
D 1 1/2"	1"	B	300	150	740	6	4	13 3/4	13		
D 2 3/4"	1"	A	150	150	285	6 1/4	4	14	13		
D 2 3/4"	1"	B	300	150	740	6 1/4	4	14	14		
D 2 3/4"	1"	C	600	150	1480	6 1/4	4	14	14		
D 2 3/4"	1"	D	600	300	1480	6 1/4	5	14	15		
D 2 3/4"	1"	E	1500	300	1750	6 1/4	5	14	18		
D 4 3/4"	1 1/2"	A	150	150	285	6 1/4	5	15 3/8	14		
D 4 3/4"	1 1/2"	B	300	150	740	6 1/4	5	15 3/8	15		
D 4 3/4"	1 1/2"	C	600	150	1480	6 1/4	5	15 3/8	16		
D 4 3/4"	1 1/2"	D	600	300	1480	6 1/4	5 3/4	15 1/8	19		
D 4 3/4"	1 1/2"	E	1500	300	1750	6 1/2	5 3/4	15 3/8	22		
D 3 1"	1"	A	150	150	285	6 1/2	4 1/4	14 1/4	14		
D 3 1"	1"	B	300	150	740	6 1/2	4 1/4	14 1/4	15		
D 3 1"	1"	C	600	150	1480	6 1/2	4 1/4	14 1/4	15		
D 3 1"	1"	D	600	300	1480	7 1/2	5	15 3/8	16		
D 3 1"	1"	E	1500	300	2000	7 1/2	5	15 3/8	20		
D 3 1"	1"	G	2500	300	2000	7 1/2	5	15 3/8	25		
D 5 1"	1 1/2"	A	150	150	285	6 1/4	5	15 1/8	15		
D 5 1"	1 1/2"	B	300	150	740	6 1/4	5	15 1/8	16		
D 5 1"	1 1/2"	C	600	150	1480	6 1/4	5	15 1/8	17		
D 5 1"	1 1/2"	D	600	300	1480	6 1/4	5 3/4	15 1/8	20		
D 5 1"	1 1/2"	E	1500	300	3500	6 1/4	5 3/4	15 1/8	24		
D 5 1"	1 1/2"	G	2500	300	3500	7 1/4	5 3/4	16 1/8	29		
D 6 1 1/2"	1 1/2"	A	150	150	285	7 1/8	5	16	17		
D 6 1 1/2"	1 1/2"	B	300	150	740	7 1/8	5	16	20		
D 6 1 1/2"	1 1/2"	C	600	150	1480	7 1/8	5	16	20		
D 6 1 1/2"	1 1/2"	D	600	300	1480	7 1/8	5 3/4	16	23		
D 6 1 1/2"	1 1/2"	E	1500	300	3500	7 1/8	5 3/4	16	32		
D 6 1 1/2"	1 1/2"	G	2500	300	3500	7 1/4	5 3/4	16 1/8	42		
E 4 3/4"	1 1/2"	A	150	150	285	6 1/4	5	15 1/8	18		
E 4 3/4"	1 1/2"	B	300	150	640	6 1/4	5	15 1/8	19		
E 4 3/4"	1 1/2"	C	600	150	640	6 1/4	5	15 1/8	20		
E 4 3/4"	1 1/2"	D	600	300	640	6 1/4	5 3/4	15 1/8	23		
E 4 3/4"	1 1/2"	E	1500	300	640	6 1/4	5 3/4	15 1/8	26		
E 5 1"	1 1/2"	A	150	150	285	6 1/4	5	15 1/8	19		
E 5 1"	1 1/2"	B	300	150	740	6 1/4	5	15 1/8	20		
E 5 1"	1 1/2"	C	600	150	1480	6 1/4	5	15 1/8	20		
E 5 1"	1 1/2"	D	600	300	1480	6 1/4	5 3/4	15 1/8	24		
E 5 1"	1 1/2"	E	1500	300	1750	7 1/4	5 3/4	16 1/8	28		
E 6 1 1/2"	1 1/2"	A	150	150	285	6 1/4	5	15 1/8	24		
E 6 1 1/2"	1 1/2"	B	300	150	740	6 1/4	5	15 1/8	24		
E 6 1 1/2"	1 1/2"	C	600	150	1480	6 1/4	5	15 1/8	24		
E 6 1 1/2"	1 1/2"	D	600	300	1480	6 1/4	5 3/4	15 1/8	23		
E 6 1 1/2"	1 1/2"	E	1500	300	2000	7 1/4	5 3/4	16 1/8	36		
E 6 1 1/2"	1 1/2"	G	2500	300	2000	7 1/4	5 3/4	16 1/8	46		
E 7 1 1/2"	2"	A	150	150	285	6 1/2	6	18 1/8	23		
E 7 1 1/2"	2"	B	300	150	740	6 1/2	6	18 1/8	26		
E 7 1 1/2"	2"	C	600	150	1480	6 1/2	6	18 1/8	26		

API Orifice Area (sq. in.) D 0.110 E 0.196 F 0.307 G 0.503	DIMENSIONS										Weight Lb. (approx.)
	Inlet	Outlet	FLANGE	Inlet	Outlet	pset (max psi)	Outlet CL to Inlet Face A	Inlet CL to Outlet Face B	Overall Height C		
E 7 1 1/2"	2"	D	600	300	1480	6 1/2	6	18 1/8	27		
E 7 1 1/2"	2"	E	1500	300	3500	8 1/4	6	19 7/8	37		
E 7 1 1/2"	2"	G	2500	300	3500	8 1/4	6	19 7/8	47		
E 8 2"	2"	A	150	150	285	6 3/4	6	18 3/8	47		
E 8 2"	2"	B	300	150	740	6 3/4	6	18 3/8	26		
E 8 2"	2"	C	600	150	1480	6 3/4	6	18 3/8	28		
E 8 2"	2"	D	600	300	1480	6 3/4	6	18 3/8	30		
E 8 2"	2"	E	1500	300	3500	8 1/4	6	19 7/8	44		
E 8 2"	2"	G	2500	300	3500	8 1/4	6	19 7/8	60		
F 5 1"	1 1/2"	A	150	150	285	6 1/4	5	18	38		
F 5 1"	1 1/2"	B	300	150	740	6 1/4	5	18	39		
F 5 1"	1 1/2"	C	600	150	740	5 1/8	5	17	37		
F 5 1"	1 1/2"	D	600	300	740	5 1/8	5 3/4	17	40		
F 6 1 1/2"	1 1/2"	A	150	150	285	6 1/2	5	18 1/8	39		
F 6 1 1/2"	1 1/2"	B	300	150	740	7 1/8	5	18 3/4	43		
F 6 1 1/2"	1 1/2"	C	600	150	1480	7 1/8	5	18 3/4	43		
F 6 1 1/2"	1 1/2"	D	600	300	1480	7 1/8	5 3/4	18 3/4	46		
F 7 1 1/2"	2"	A	150	150	285	6 1/2	6	18 1/8	42		
F 7 1 1/2"	2"	B	300	150	740	6 1/2	6	18 1/8	45		
F 7 1 1/2"	2"	C	600	150	1480	6 1/2	6	18 1/8	45		
F 7 1 1/2"	2"	D	600	300	1480	6 1/2	6	18 1/8	46		
F 7 1 1/2"	2"	E	1500	300	1500	8 1/4	6	19 7/8	55		
F 8 2"	2"	A	150	150	285	6 3/4	6	18 3/8	44		
F 8 2"	2"	B	300	150	740	6 3/4	6	18 3/8	46		
F 8 2"	2"	C	600	150	1480	6 3/4	6	18 3/8	47		
F 8 2"	2"	D	600	300	1480	6 3/4	6	18 3/8	49		
F 8 2"	2"	E	1500	300	1500	8 1/4	6	19 7/8	63		
G 7 1 1/2"	2"	A	150	150	285	7 1/8	6 1/2	21	45		
G 7 1 1/2"	2"	B	300	150	740	7 1/8	6 1/2	21	48		
G 7 1 1/2"	2"	C	600	150	1480	7 1/8	6 1/2	21	50		
G 7 1 1/2"	2"	D	600	300	1480	7 1/8	6 1/2	21	51		
G 9 1 1/2"	2 1/2"	A	150	150	285	7 1/8	6 1/2	21	50		
G 9 1 1/2"	2 1/2"	B	300	150	740	7 1/8	6 1/2	21	55		
G 9 1 1/2"	2 1/2"	C	600	150	1480	7 1/8	6 1/2	21	53		
G 9 1 1/2"	2 1/2"	D	600	300	1480	7 1/8	6 1/2	21	56		
G 9 1 1/2"	2 1/2"	E	1500	300	1500	8 1/4	6 1/2	22 1/4	63		
G 8 2"	2"	A	150	150	285	7 1/8	6 1/2	21	48		
G 8 2"	2"	B	300	150	740	7 1/8	6 1/2	21	51		
G 8 2"	2"	C	600	150	1480	7 1/8	6 1/2	21	51		
G 8 2"	2"	D	600	300	1480	7 1/8	6 1/2	21	54		
G 0 2"	2 1/2"	A	150	150	285	7 1/8	6 1/2	21	54		
G 0 2"	2 1/2"	B	300	150	740	7 1/8	6 1/2	21	55		
G 0 2"	2 1/2"	C	600	150	1480	7 1/8	6 1/2	21	56		
G 0 2"	2 1/2"	D	600	300	1480	7 1/8	6 1/2	21	58		
G 0 2"	2 1/2"	E	1500	300	1500	8 1/4	6 1/2	22	72		

Overall height with lever: Add 1" to C, D & E Valves  
 Add 1 1/2" to F & G Valves

Competitor's dimensions available  
 Sanitary fitting connections available



**M**

**SEAT TYPE**

M	Metal
C	Neoprene
E	EPDM
K	Kalrez
N	Nitrile
P	Polyurethane
S	Silicone
V	Fluorocarbon

**O**

**BILL OF MATERIALS**

	BODY	SPRING	TRIM
0	WCB	CV	316SS
1	WCB	316SS	316SS
2	WCB	Inconel X750	316SS
3	CF8M	316SS	316SS
4	CF8M	Inconel X750	316SS
5	Monel	Inconel X750	Monel
6	WCB	Inconel X750	Monel
7	WCB	Inconel X750	Hastelloy C
8	Hastelloy C	Hastelloy C	Hastelloy C
X	Special		

**O**

**CAP TYPE**

O	Closed
L	Open Lever
P	Packed lever
G	Closed/W Gag
M	Open Gag
S	Packed/W Gag
ASME code requires lift lever on air, steam or water over 140° F	

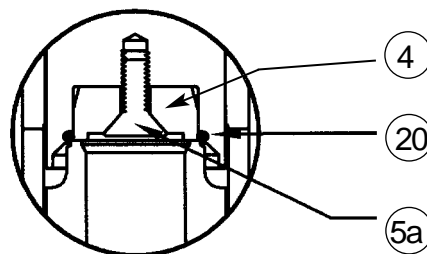

Soft Seat Option

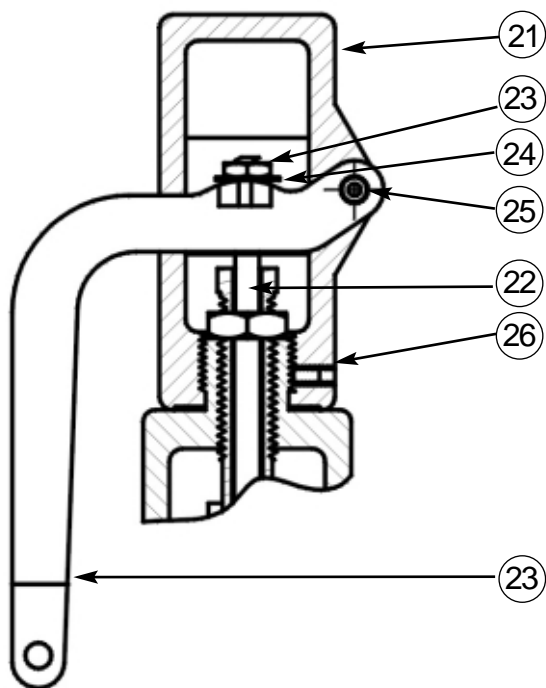

Open Lift Lever

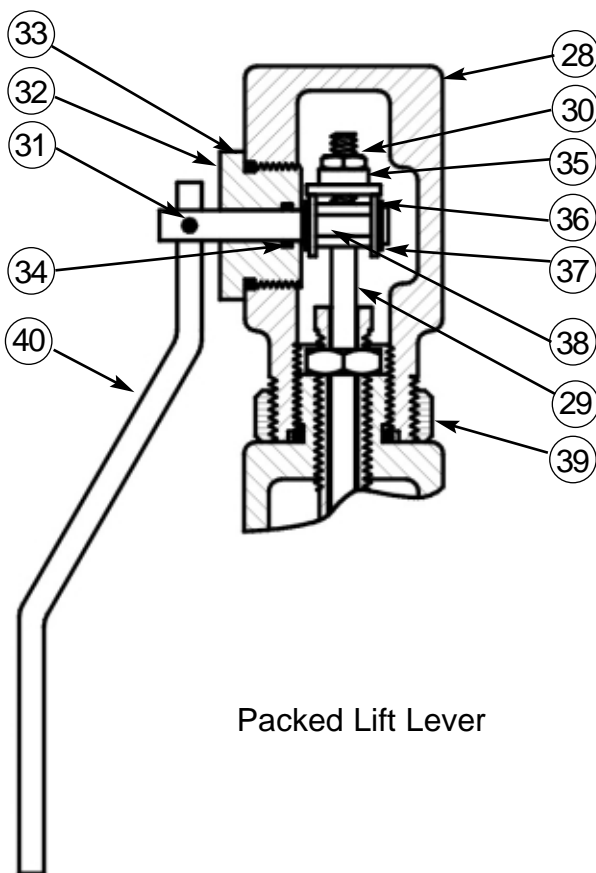

Packed Lift Lever

# Series 1500 Material Selections

## BILL OF MATERIALS

ITEM	PART NAME	0	1	2	3
		-20°F to +450°F (-29°C to +232°C)	-20°F to +650°F (-29°C to +343°C)	NACE MR 0175 -20°F to +750°F (-29°C to +399°C)	-425°F to +800°F (-254°C to +426°C)
1	Nozzle	316SS	316SS	316SS	316SS
2	Guide	316SS	316SS	316SS	316SS
3	Body	WCB	WCB	WCB	CF8M
4	Disc	316SS	316SS	316SS	316SS
5	Disc Retainer	316SS	316SS	316SS	316SS
5a (1)	Disc Retainer Screw	316SS	316SS	316SS	316SS
6	Disc Holder	316SS	316SS	316SS	316SS
7	Stem Head	316SS	316SS	316SS	316SS
9	Spring	CV	316SS (3)	Inconel X750	316SS (3)
10	Stem	316SS	316SS	316SS	316SS
11	Spring Plate	316SS	316SS	316SS	316SS
12	O-Ring	Specify	Specify	Specify	Specify
13	Adjusting Nut	Carbon Steel	Carbon Steel	316SS	316SS
14	Adjusting Screw	316SS	316SS	316SS	316SS
15	Cap	Carbon Steel	Carbon Steel	Carbon Steel	316SS
16	Lap Joint Stub End (Inlet)	316SS	316SS	316SS	316SS
17	Lap Joint Flange (Inlet)	Carbon Steel	Carbon Steel	Carbon Steel	316SS
18	Lap Joint Stub End (Outlet)	Carbon Steel	Carbon Steel	Carbon Steel	316SS
19	Lap Joint Flange (Outlet)	Carbon Steel	Carbon Steel	Carbon Steel	316SS
20	O-Ring(1)	Specify	Specify	Specify	Specify
21	Cap	WCB	WCB	WCB	CF8M
22	Stem	316SS	316SS	316SS	316SS
23	Release Nut	Carbon Steel	Carbon Steel	Carbon Steel	316SS
24	Release Washer	Carbon Steel	Carbon Steel	Carbon Steel	316SS
25	Lever Pin	Carbon Steel	Carbon Steel	Carbon Steel	316SS
26	Cap Retainer Screw	Carbon Steel	Carbon Steel	Carbon Steel	316SS
27	Lever	Carbon Steel	Carbon Steel	Carbon Steel	316SS
28	Cap	WCB	WCB	WCB	CF8M
29	Stem	316SS	316SS	316SS	316SS
30	Release Nut	Carbon Steel	316SS	316SS	316SS
31	Lever Pin	Carbon Steel	Carbon Steel	Carbon Steel	302SS
32	Gland Nut	Carbon Steel	316SS	Carbon Steel	316SS
33	Gland O-ring	(4)	(4)	(4)	(4)
34	Shaft O-ring	(4)	(4)	(4)	(4)
35	Release Washer	Carbon Steel	Carbon Steel	Carbon Steel	316SS
36	Snap Ring	Carbon Steel	Carbon Steel	Carbon Steel	316SS
37	Lever Dog	316SS	316SS	316SS	316SS
38	Lever Shaft	316SS	316SS	316SS	316SS
39	Lock Nut	Carbon Steel	Carbon Steel	Carbon Steel	316SS
40	Lever	Carbon Steel	Carbon Steel	Carbon Steel	316SS

(1) Soft Seat Valve Only

(3) Hydroseal reserves the right to substitute Inconel X 750 in lieu of 316SS for higher pressure springs  
(4) Same as item 12

WCB - ASME SA 216  
Carbon Steel - ASTM A105

CF8M - ASME SA 351  
Monel - ASME SB494 Grade 35-1  
See table on F2 for maximum soft seat temperatures



## BILL OF MATERIALS

4	5	6	7	9
NACE MR 0175 -425°F to +800°F (-254°C to +426°C)	-320°F to + 800°F (-196°C to + 426°C)	-20°F to +750°F (-29°C to +399°C)	-20°F to +750°F (-29°C to +399°C)	-320°F to + 800°F (-196°C to + 426°C)
316SS	Monel	Monel	Hastelloy C	Hastelloy C
316SS	Monel	Monel	Hastelloy C	Hastelloy C
CF8M	Monel	WCB	WCB	Hastelloy C
316SS	Monel	Monel	Hastelloy C	Hastelloy C
316SS	Monel	Monel	Hastelloy C	Hastelloy C
316SS	Monel	Monel	Hastelloy C	Hastelloy C
316SS	Monel	316SS	316SS	Hastelloy C
Inconel X750	Inconel X750	Inconel X750	Inconel X750	Hastelloy C
316SS	Monel	316SS	316SS	Hastelloy C
316SS	Monel	316SS	316SS	Hastelloy C
Specify	Specify	Specify	Specify	Specify
316SS	Monel	316SS	316SS	Hastelloy C
316SS	Monel	316SS	316SS	Hastelloy C
316SS	Monel	Carbon Steel	Carbon Steel	Hastelloy C
316SS	Monel	Monel	Hastelloy C	Hastelloy C
316SS	Carbon Steel	Carbon Steel	Carbon Steel	Carbon Steel
316SS	Monel	Carbon Steel	Carbon Steel	Hastelloy C
316SS	Carbon Steel	Carbon Steel	Carbon Steel	Carbon Steel
Specify	Specify	Specify	Specify	Specify
CF8M	CF8M	CF8M	CF8M	CF8M
316SS	316SS	316SS	316SS	316SS
316SS	316SS	316SS	316SS	316SS
316SS	316SS	316SS	316SS	316SS
316SS	316SS	316SS	316SS	316SS
316SS	316SS	316SS	316SS	316SS
316SS	316SS	316SS	316SS	316SS
CF8M	Monel	Monel	Hastelloy C	Hastelloy C
316SS	316SS	316SS	316SS	316SS
316SS	Monel	Monel	Hastelloy C	Hastelloy C
302SS	302SS	302SS	302SS	302SS
316SS	Monel	Monel	Hastelloy C	Hastelloy C
(4)	(4)	(4)	(4)	(4)
(4)	(4)	(4)	(4)	(4)
316SS	Monel	Monel	Hastelloy C	Hastelloy C
316SS	Inconel	Inconel	Hastelloy C	Hastelloy C
316SS	Monel	Monel	Hastelloy C	Hastelloy C
316SS	Monel	Monel	Hastelloy C	Hastelloy C
316SS	316SS	316SS	316SS	316SS
316SS	316SS	316SS	316SS	316SS

### TRADEMARKS

Hastelloy is a trademark of the Stellite Division of Cabot Corporation  
 Inconel is a trademark of Huntington Alloys, Incorporated  
 Monel is a trademark of Huntington Alloys, Incorporated  
 Teflon is a trademark of duPont de Nemours & Company, Inc.  
 Viton is a trademark of Du Pont Dow Elastomers L.L.C.  
 17-4 PH is a trademark of Armco Steel Corporation

# Series 1500 Air Capacities

## AIR CAPACITIES IN SCFM AT 60°F AT 10% OVERPRESSURE [ASME SEC VIII]

ORIFICE AREA [SQ. IN.]	D 0.129	E 0.230	F 0.366	G 0.590
SET PRESSURE PSIG				
15	67	120	191	308
20	78	138	220	355
25	88	157	249	402
30	98	175	278	449
35	109	195	311	501
40	121	215	343	552
45	132	235	375	604
50	143	256	407	656
55	155	296	439	708
60	166	296	471	759
65	177	316	503	811
70	189	336	535	863
75	200	357	567	915
80	211	377	599	968
85	223	397	632	1016
90	234	417	664	1070
95	245	437	696	1122
100	257	457	728	1173
105	268	478	760	1225
110	279	498	792	1277
115	290	518	824	1329
120	302	538	856	1380
125	313	558	888	1432
130	324	578	920	1484
135	336	599	953	1536
140	347	619	985	1587
145	358	639	1017	1639
150	370	659	1049	1691
155	381	679	1081	1743
160	392	699	1113	1794
165	404	720	1145	1846
170	415	740	1177	1898
175	426	760	1209	1950
180	438	780	1242	2001
185	449	800	1274	2053
190	460	821	1306	2105
195	472	841	1338	2157
200	483	861	1370	2208
210	505	901	1434	2312
220	528	942	1498	2415
230	551	982	1863	2519

ORIFICE AREA [SQ. IN.]	D 0.129	E 0.230	F 0.366	G 0.590
SET PRESSURE PSIG				
250	596	1063	1691	2726
260	619	1103	1755	2829
270	641	1143	1819	2933
280	664	1184	1884	3036
290	687	1224	1948	3140
300	709	1264	2012	3243
320	754	1345	2140	3450
340	800	1426	2269	3657
360	845	1506	2397	3864
380	890	1587	2526	4071
400	935	1668	2654	4278
420	981	1749	2782	4485
440	1026	1829	2911	4692
460	1071	1910	3039	4899
480	1116	1991	3168	5106
500	1162	2071	3296	5313
520	1207	2152	3553	4485
540	1252	2233	3553	5727
560	1296	2313	3618	5943
580	1343	2394	3810	6141
600	1388	2475	3938	6348
620	1433	2556	4067	6555
640	1479	2636	4195	6762
660	1524	2717	4323	6969
680	1569	2798	4452	7176
700	1614	2878	4580	7383
720	1660	2959	4709	7590
740	1705	3040	4837	7797
760	1750	3120	4965	8004
780	1795	3201	5094	8211
800	1841	3282	5222	8419
820	1886	3362	5351	8626
840	1931	3343	5479	8833
860	1976	3524	5608	9040
880	2022	3605	5736	9247
900	2067	3685	5864	9454
920	2112	3766	5993	9661
940	2157	3847	6121	9868
960	2248	3927	6250	10075
980	2248	4008	6378	10282
1000	2293	4089	6506	10489

ORIFICE AREA [SQ. IN.]	D 0.129	E 0.230	F 0.366	G 0.590
SET PRESSURE PSIG				
1040	2384	4250	6763	10903
1060	2429	4331	6892	11110
1080	2474	4412	7020	11317
1100	2520	4492	7149	11524
1120	2565	4573	7277	11731
1140	2610	4654	7405	11938
1160	2655	4734	7534	12145
1180	2701	4815	7662	12352
1200	2746	4896	7791	12559
1220	2791	4976	7919	12766
1240	2836	5057	8047	12973
1260	2882	5138	8176	13180
1280	2927	5219	8304	13387
1300	2972	5299	8433	13594
1320	3017	5380	8561	13801
1340	3063	5461	8689	14008
1360	3108	5541	8818	14215
1380	3153	5622	8946	14422
1400	3198	5703	9075	14629
1420	3244	5783	9203	14836
1440	3289	5864	9332	15043
1460	3334	5945	9460	15250
1480	3380	6025	9588	15457
1500	3425	6106	9717	15664
1520	3470	6187	•	•
1540	3515	6268	•	•
1560	3561	6346	•	•
1580	3606	6429	•	•
1600	3651	6510	•	•
1620	3696	6590	•	•
1640	3742	6671	•	•
1660	3787	6752	•	•
1680	3832	6832	•	•
1700	3877	6913	•	•
1720	3923	6994	•	•
1740	3968	7075	•	•
1760	4013	7155	•	•
1780	4058	7236	•	•
1800	4104	7317	•	•
1820	4149	7397	•	•
1840	4194	7478	•	•



**AIR CAPACITIES IN SCFM AT 10% OVERPRESSURE [ASME SEC VIII]**

ORIFICE AREA [SQ. IN.]	D 0.129	E 0.230	F 0.366	G 0.590
1900	4330	7720	•	•
1920	4375	7801	•	•
1940	4420	7882	•	•
1960	4466	7962	•	•
1980	4602	8204	•	•
2000	4647	8285	•	•
2020	4602	8204	•	•
2040	4647	8285	•	•
2060	4692	8366	•	•
2080	4737	8446	•	•
2100	4783	8527	•	•
2120	4828	8608	•	•
2140	4873	8688	•	•
2160	4918	8769	•	•
2180	4964	8850	•	•
2200	5054	9011	•	•
2220	5054	9011	•	•
2240	5099	9092	•	•
2260	5145	9173	•	•
2280	5190	9415	•	•
2300	5326	9495	•	•
2320	5280	9415	•	•
2340	5326	9495	•	•
2360	5371	9576	•	•
2380	5416	9657	•	•
2400	5461	9738	•	•
2420	5507	9818	•	•

ORIFICE AREA [SQ. IN.]	D 0.129	E 0.230	F 0.366	G 0.590
2440	5552	9899	•	•
2460	5597	9980	•	•
2480	5643	10060	•	•
2500	5688	10141	•	•
2520	5733	10222	•	•
2540	5778	10302	•	•
2560	5824	10383	•	•
2580	5869	10464	•	•
2600	5914	10544	•	•
2620	5959	10625	•	•
2640	6005	10706	•	•
2660	6050	10787	•	•
2680	6095	10867	•	•
2700	6140	10948	•	•
2720	6186	11029	•	•
2740	6231	11109	•	•
2760	6276	11190	•	•
2780	6321	11271	•	•
2800	6367	11674	•	•
2820	6412	11432	•	•
2840	6457	11513	•	•
2860	6502	11594	•	•
2880	6548	11674	•	•
2900	6593	11755	•	•
2920	6638	11836	•	•
2940	6684	11916	•	•
2960	6729	11997	•	•

ORIFICE AREA [SQ. IN.]	D 0.129	E 0.230	F 0.366	G 0.590
2980	6774	12078	•	•
3000	6819	12158	•	•
3020	6865	12239	•	•
3040	6910	12320	•	•
3060	6955	12401	•	•
3080	7000	12481	•	•
3100	7046	12562	•	•
3120	7091	12643	•	•
3140	7136	12723	•	•
3160	7181	12804	•	•
3180	7227	12885	•	•
3200	7272	12965	•	•
3220	7317	13046	•	•
3240	7362	13127	•	•
3260	7408	13207	•	•
3280	7453	13288	•	•
3300	7498	13369	•	•
3320	7543	13450	•	•
3340	7589	13530	•	•
3360	7634	13611	•	•
3380	7679	13692	•	•
3400	7724	13772	•	•
3420	7770	13853	•	•
3440	7815	13934	•	•
3460	7860	14014	•	•
3480	7906	14095	•	•
3500	7951	14176	•	•

**ASME SECTION VIII CAPACITY SIZING FORMULA:  
AIR (SCFM)**

- Q = 18.331 APK @ 60°F & 14.7 psia
- P = Set pressure + (3 psi or 10%, whichever is greater) + 14.7 psia
- K = 0.870
- A = Area (sq. in.)
  - 0.129 (D orifice)
  - 0.230 (E orifice)
  - 0.366 (F orifice)
  - 0.590 (G orifice)

**ASME SECTION VIII CAPACITY SIZING FORMULA:  
GAS OR VAPOR LB/HR**

- W = CKAP  $\sqrt{MT}$
- K = 0.870
- C = Gas/vapor constant based on ratio of specific heats Cp/Cv
- P = Set pressure + (3 psi or 10%, whichever is greater) + 14.7 psia
- A = 0.129 (D orifice)
  - 0.230 (E orifice)
  - 0.366 (F orifice)
  - 0.590 (G orifice)
- M = Molecular weight
- T = Absolute temperature, °R (°F+460)
- W = Flow lb/hr gas

# Series 1500 Water Capacities

## LIQUID CAPACITIES IN GPM (U.S.) AT 70°F AT 10% OVERPRESSURE [ASME SEC VIII]

ORIFICE AREA [SQ. IN.]	D 0.129	E 0.230	F 0.366	G 0.590	ORIFICE AREA [SQ. IN.]	D 0.129	E 0.230	F 0.366	G 0.590	ORIFICE AREA [SQ. IN.]	D 0.129	E 0.230	F 0.366	G 0.590
SET PRESSURE PSIG					SET PRESSURE PSIG					SET PRESSURE PSIG				
15	14	25	40	64	250	55	97	155	250	1040	111	199	316	510
20	16	28	45	72	260	56	99	158	255	1060	112	201	319	514
25	17	31	49	80	270	57	101	161	260	1080	114	202	322	519
30	19	34	54	87	280	58	103	164	264	1100	115	204	325	524
35	20	36	58	93	290	59	105	167	269	1120	116	206	328	529
40	22	39	62	100	300	60	107	170	274	1140	117	208	331	534
45	23	41	66	106	320	62	110	175	283	1160	118	210	334	538
50	24	44	69	112	340	64	114	181	291	1180	119	212	337	543
55	26	46	73	117	360	66	117	186	300	1200	120	213	340	547
60	27	48	76	122	380	67	120	191	308	1220	121	215	342	552
65	28	50	79	127	400	69	123	196	316	1240	122	217	345	556
70	29	52	82	132	420	71	126	201	324	1260	123	219	348	561
75	30	53	85	137	440	72	129	206	331	1280	124	220	351	565
80	31	55	88	141	460	74	132	210	339	1300	125	222	353	570
85	32	57	90	146	480	76	135	215	346	1320	126	224	356	574
90	33	58	93	150	500	77	138	219	353	1340	126	225	359	578
95	34	60	96	154	520	79	140	224	360	1360	127	227	361	583
100	35	62	98	158	540	80	143	228	367	1380	128	229	364	587
105	35	63	100	162	560	82	146	232	374	1400	129	230	367	591
110	36	65	103	166	580	83	148	236	381	1420	130	232	369	595
115	37	66	105	169	600	85	151	240	387	1440	131	234	372	600
120	38	67	107	173	620	86	153	244	393	1460	132	235	375	604
125	39	69	110	177	640	87	156	248	400	1480	133	237	377	608
130	39	70	112	180	660	89	158	252	406	1500	134	239	380	612
135	40	72	114	184	680	90	161	256	412	1520	135	240	•	•
140	41	73	116	187	700	91	163	259	418	1540	136	242	•	•
145	42	74	118	190	720	93	165	263	424	1560	136	243	•	•
150	42	75	120	194	740	94	168	267	430	1580	137	245	•	•
155	43	78	124	200	760	95	170	270	436	1600	138	246	•	•
160	44	78	124	200	780	96	172	274	441	1620	139	248	•	•
165	44	79	126	203	800	98	174	277	447	1640	140	249	•	•
170	45	80	128	206	820	99	176	281	452	1660	141	251	•	•
175	46	81	130	209	840	100	179	284	458	1680	142	252	•	•
180	46	83	132	212	860	101	181	287	463	1700	142	252	•	•
185	47	84	133	215	880	102	183	291	469	1720	143	225	•	•
190	48	85	135	218	900	104	185	294	474	1740	144	257	•	•
195	48	86	137	221	920	105	187	297	479	1760	145	258	•	•
200	49	87	139	223	940	106	189	301	484	1780	146	260	•	•
210	50	89	142	229	960	107	191	304	490	1800	147	261	•	•
220	51	91	145	234	980	108	193	307	495	1820	147	263	•	•
230	52	93	149	24	1000	109	195	310	500	1840	148	264	•	•



**LIQUID CAPACITIES IN GPM AT 10% OVERPRESSURE [ASME SEC VIII]**

ORIFICE AREA [SQ. IN.]	D	E	F	G	ORIFICE AREA [SQ. IN.]	D	E	F	G	ORIFICE AREA [SQ. IN.]	D	E	F	G
	0.129	0.230	0.366	0.590		0.129	0.230	0.366	0.590		0.129	0.230	0.366	0.590
SET PRESSURE PSIG					SET PRESSURE PSIG					SET PRESSURE PSIG				
1900	151	268	•	•	2440	171	304	•	•	2980	189	336	•	•
1920	151	270	•	•	2460	171	306	•	•	3000	189	337	•	•
1940	152	271	•	•	2480	172	307	•	•	3020	190	339	•	•
1960	153	273	•	•	2500	173	308	•	•	3040	190	340	•	•
1980	154	274	•	•	2520	173	309	•	•	3060	191	341	•	•
2000	155	275	•	•	2540	174	310	•	•	3080	192	342	•	•
2020	155	277	•	•	2560	175	312	•	•	3100	192	343	•	•
2040	156	278	•	•	2580	175	313	•	•	3120	193	344	•	•
2060	157	280	•	•	2600	176	314	•	•	3140	194	345	•	•
2080	158	281	•	•	2620	177	315	•	•	3160	194	346	•	•
2100	158	282	•	•	2640	178	316	•	•	3180	195	347	•	•
2120	159	284	•	•	2660	178	318	•	•	3200	195	348	•	•
2140	160	285	•	•	2680	179	319	•	•	3220	196	348	•	•
2160	161	286	•	•	2700	180	320	•	•	3240	197	351	•	•
2180	161	288	•	•	2720	180	321	•	•	3260	197	352	•	•
2200	162	289	•	•	2740	181	322	•	•	3280	198	353	•	•
2220	163	290	•	•	2760	182	324	•	•	3300	198	354	•	•
2240	164	292	•	•	2780	182	325	•	•	3320	199	355	•	•
2260	164	293	•	•	2800	183	326	•	•	3340	200	356	•	•
2280	165	294	•	•	2820	183	327	•	•	3360	200	357	•	•
2300	166	295	•	•	2840	184	328	•	•	3380	201	358	•	•
2320	166	297	•	•	2860	185	329	•	•	3400	201	359	•	•
2340	167	298	•	•	2880	185	331	•	•	3420	202	360	•	•
2360	168	299	•	•	2900	186	332	•	•	3440	203	361	•	•
2380	169	301	•	•	2920	187	333	•	•	3460	203	362	•	•
2400	169	302	•	•	2940	187	334	•	•	3480	204	363	•	•
2420	170	303	•	•	2960	188	335	•	•	3500	204	364	•	•

**ASME SECTION VIII CAPACITY SIZING FORMULA: WATER (GPM, US)**

W = 4.814 AK  $\sqrt{w(P-P_d)}$

K = 0.672

w = 62.3058 lbs/Ft<sup>3</sup> @ 70° F

P = Set pressure + (3 psi or 10%, whichever is greater) + 14.7 psia

P<sub>d</sub> = Discharge pressure

A = Area (sq. in.)

0.129 (D orifice)

0.230 (E orifice)

0.366 (F orifice)

0.590 (G orifice)

# Series 1500 Dry Saturated Steam Capacities



## STEAM CAPACITIES IN POUNDS PER HOUR AT 10% OVERPRESSURE [ASME SEC VIII]

ORIFICE AREA [SQ. IN.]	D 0.129	E 0.230	F 0.366	G 0.590
SET PRESSURE PSIG				
15	189	337	536	864
20	218	389	618	997
25	247	440	700	1129
30	276	492	782	1261
35	307	548	872	1406
40	339	605	963	1552
45	371	662	1053	1697
50	403	718	1143	1843
55	435	775	1233	1988
60	466	832	1323	2133
65	498	888	1414	2279
70	530	945	1504	2424
75	562	1002	1594	2569
80	594	1058	1684	2715
85	625	1115	1774	2860
90	657	1172	1865	3006
95	689	1228	1955	3151
100	721	1285	2045	3296
110	784	1398	2225	3587
120	848	1512	2406	3878
130	911	1625	2586	4169
140	975	1735	2766	4460
150	1039	1852	2947	4750
160	1102	1965	3127	5041
170	1166	2079	3308	5332
180	1229	2192	3488	5623
190	1293	2305	3668	5913
200	1357	2419	3849	6204
210	1420	2530	4029	6495
220	1484	2645	4210	6786
230	1547	2759	4390	7077
240	1611	2872	4570	7367
250	1674	2985	4751	7658
260	1738	3099	4931	7949

ORIFICE AREA [SQ. IN.]	D 0.129	E 0.230	F 0.366	G 0.590
SET PRESSURE PSIG				
270	1802	3212	5111	8240
280	1865	3325	5292	8531
290	1929	3439	5472	8821
300	1992	3552	5653	9112
310	2056	3666	5833	9403
320	2119	3779	6013	9694
330	2183	3892	6194	9984
340	2247	4006	6374	10275
350	2310	4119	6555	10566
360	2374	4232	6735	10857
370	2437	4346	6915	11148
380	2501	4459	7096	11438
390	2565	4572	7276	11729
400	2628	4686	7456	12020
410	2692	4799	7637	12311
420	2755	4912	7817	12602
440	2882	5139	8178	13183
450	2946	5253	8358	13474
460	3010	5366	8539	13765
470	3073	5479	8719	14055
480	3137	5593	8900	14346
490	3200	5706	9080	14637
500	3264	5819	9260	14928
510	3327	5933	9441	15219
520	3391	6046	9621	15509
530	3455	6159	9801	15800
540	3518	6273	9982	16091
550	3582	6386	10162	16382
560	3645	6499	10343	16673
570	3709	6613	10523	16963
580	3773	6726	10703	17254
590	3836	6840	10884	17545
600	3900	6953	11064	17836

### ASME SECTION VIII CAPACITY SIZING FORMULA: STEAM (LBS/HR)

- W = Lbs/Hr steam = 51.5 APK
- K = 0.870
- P = Set pressure + 0(3 psi or 10%, whichever is greater) + 14.7 psia
- A = Area (sq. in.) =
  - 0.129 (D orifice)
  - 0.230 (E orifice)
  - 0.366 (F orifice)
  - 0.590 (G orifice)



1610 U.S. Hwy 259 N. • Kilgore, Texas 75662  
 903-984-8574 • Fax 903-984-6307  
[www.hydroseal.com](http://www.hydroseal.com)

