



# Model 85 Heavy-Duty Y Strainers

1/4" to 10" • Iron, Bronze, Carbon Steel and Stainless Steel • Threaded, Flanged and Socket Weld Connections

**Rugged Design**



*Carbon steel and stainless steel Y strainers are offered in sizes for 1/4 in to 10 in pipelines*



*Cast iron Y strainers are offered in sizes for 1/4 in to 10 in pipelines*



*Bronze Y strainer are offered in sizes from 1/4 in to 6 in*

## Features

- Heavy Duty Construction
- Compact Design
- Bolted or Threaded Covers
- Standard Stainless Steel Screens
- Synthetic Fiber Gaskets

## Options

- 1/32" to 1/2" Perforated Stainless Steel Screens
- 40, 60, 80, 100, 200, 325 and 400 Mesh Stainless Steel Screens
- Monel Screens
- Chrome-Moly Construction
- Ring Type Joint Connections
- Butt Weld Connections
- 900#, 1500#, and 2500# Ratings Available

**H**ayward Model 85 Y Strainers are heavy duty ones – engineered to stand up to the most aggressive of industrial and commercial applications...year after year. There is simply no higher quality Y strainer available...at any cost.

It may seem strange to discuss quality as a special feature of a basically simple Y strainer, however, it is appropriate when you consider the critical operational parameters often associated with Y strainers used in steam and gas applications, extremely high temperatures and high pressures. A Y strainer is a pressure vessel, its wall thickness can be analyzed and evaluated by different applicable standards. Hayward does not, and never will, compromise or stint on wall thickness. Every rugged Hayward Model 85 Y strainer is designed to stand up the most demanding real world applications. Hayward's over 75 years experience in manufacturing strainers ensures this.

There is a tendency to trivialize quality, particularly when price becomes a dominant consideration. What this design consideration amounts to in non-critical, light duty applications is an extra element of safety, as well as longer, more dependable service. We extend our preoccupation with quality to each screen that is supplied with Hayward Y strainers. It should not come as a surprise to learn that those Y strainers, whose bodies are trimmed to a bare minimum for cost reasons, are equipped with screens that lack structural integrity and are poorly seated and sealed. Hayward heavy duty Model 85 Y strainers are furnished with high quality stainless steel screens that are carefully fabricated to fit the strainer body perfectly. This, coupled with the precision machined screen seat on the body of the strainer, protects against any bypass..

Hayward Model 85 Heavy Duty Y Strainers are available in iron, bronze, carbon steel or stainless steel for pipeline sizes from 1/4" to 10", with threaded, flanged, or socket weld connections. Do you have a unique application where a standard strainer just won't work? Or...do you need special materials of construction, super high pressure ratings, special dimensions? Contact us. Our engineers will design and fabricate a strainer to match the requirements of the most complex applications.

# Y Strainers



## Selection Charts

Size	Material	End Connections *	Cover	Rating	Seals
1/4" to 3"	Cast Iron	Threaded 250#	Threaded	400 psi @ 150 F	Compressed, Non-Asbestos, Synthetic Fiber
2" to 10"		Flanged 125# or Flanged 250#	Bolted	200 psi @ 150 F 500 psi @ 150 F	
1/4" to 2"	Bronze	Threaded or Socket End 150#	Threaded	200 psi @ 100 F	
2" to 6"		Flanged 150#	Bolted	225 psi @ 100 F	

Size	Material	End Connections *	Cover	Rating	Seals
1/4" to 2"	Carbon Steel	Threaded or Socket Weld 600#	Threaded	1480 psi @ 100F	Compressed, Non-Asbestos, Synthetic Fiber
	Stainless Steel			1440 psi @ 100F	
2" to 10"	Carbon Steel	Flanged 150# Flanged 300# Flanged 150# Flanged 300#	Bolted	285 psi @ 100F	
				740 psi @ 100F	
	Stainless Steel			275 psi @ 100F	
				720 psi @ 100F	

\* DIN flanges and BSP threads available

## Dimensional Drawings

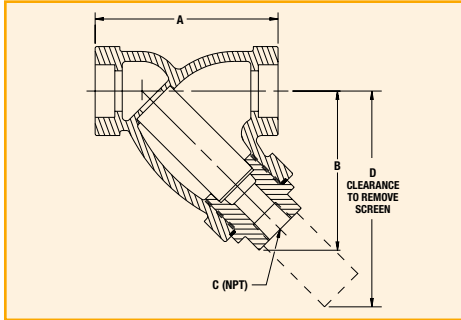

Typical Solder End Y Strainer

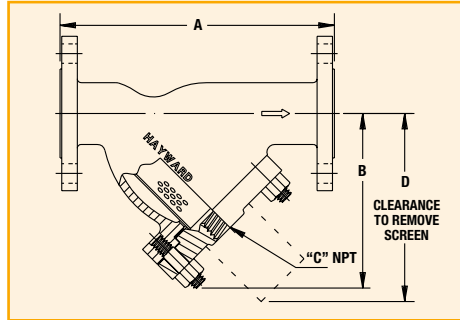

Typical Flanged Y Strainer

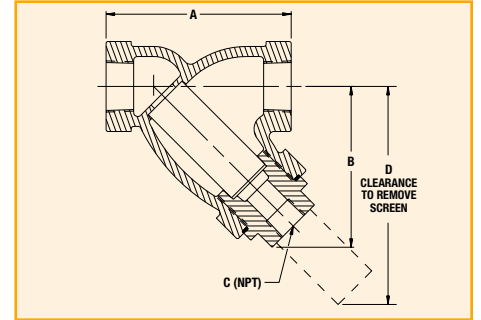

Typical Threaded Y Strainer

### Flanged Carbon Steel and Stainless Steel – 150 lb (in / mm)

Size	A	B	C (Nom.)	D	Wt (lb / kg)
1/2	5.00 / 127	2.75 / 70	3/8 / 10	3.50 / 89	5 / 2.3
3/4	5.63 / 143	3.00 / 76	3/8 / 10	4.00 / 102	7 / 3.2
1	6.38 / 162	3.64 / 92	1/2 / 15	5.00 / 127	9 / 4.1
1-1/4	7.25 / 184	4.25 / 108	3/4 / 20	5.75 / 146	14 / 6.3
1-1/2	8.88 / 226	5.75 / 146	3/4 / 20	6.50 / 165	18 / 8.2
2	7.88 / 200	6.00 / 152	1 / 25	8.25 / 210	16 / 7.3
2-1/2	9.75 / 248	6.50 / 165	1 / 25	9.25 / 235	25 / 11.4
3	10.00 / 254	7.25 / 184	1-1/4 / 32	10.50 / 267	35 / 16
4	12.13 / 308	9.75 / 248	1-1/2 / 40	14.75 / 375	70 / 32
6	18.50 / 470	14.25 / 362	2 / 50	21.00 / 533	130 / 59
8	21.63 / 549	18.00 / 457	2 / 50	26.75 / 679	240 / 109
10	26.00 / 660	22.50 / 565	2 / 50	33.75 / 857	300 / 136

### Flanged Carbon Steel and Stainless Steel – 300 lb (in / mm)

Size	A	B	C (Nom.)	D	Wt (lb / kg)
1/2	5.25 / 133	2.75 / 70	3/8 / 10	3.50 / 89	6 / 2.7
3/4	6.00 / 152	3.00 / 76	3/8 / 10	4.00 / 102	9 / 4.1
1	6.88 / 175	3.63 / 92	1/2 / 15	5.00 / 127	13 / 6.0
1-1/4	7.75 / 197	4.25 / 108	3/4 / 20	5.75 / 146	18 / 8.2
1-1/2	9.38 / 238	5.75 / 146	3/4 / 20	6.50 / 165	24 / 11
2	8.63 / 219	6.25 / 159	1 / 25	8.25 / 210	30 / 13.6
2-1/2	10.63 / 270	7.00 / 178	1 / 25	9.25 / 235	40 / 18.2
3	12.00 / 305	7.75 / 197	1-1/4 / 32	10.50 / 267	55 / 25
4	14.50 / 368	10.50 / 267	1-1/2 / 40	14.75 / 375	105 / 48
6	20.00 / 508	14.75 / 375	2 / 50	21.00 / 533	200 / 91
8	23.38 / 594	18.75 / 476	2 / 50	27.00 / 686	360 / 164
10	27.38 / 695	22.75 / 578	2 / 50	34.50 / 876	430 / 195

### Socket Weld and Threaded Carbon Steel and Stainless Steel – 600 lb (in / mm)

Size	A	B	C (Nom.)	D	Wt (lb / kg)
1/4	3.00 / 76	3.00 / 76	3/8 / 10	4.00 / 102	2 / 0.9
3/8	3.00 / 76	3.00 / 76	3/8 / 10	4.00 / 102	2 / 0.9
1/2	3.00 / 76	3.00 / 76	3/8 / 10	4.00 / 102	2 / 0.9
3/4	3.75 / 95	3.50 / 89	3/8 / 10	4.75 / 121	4 / 1.8
1	4.63 / 118	4.00 / 102	1/2 / 15	5.75 / 146	6 / 2.7
1-1/4	5.00 / 127	4.63 / 118	3/4 / 20	6.50 / 165	8 / 3.6
1-1/2	5.63 / 143	5.25 / 133	3/4 / 20	7.50 / 191	10 / 4.5
2	7.00 / 178	5.75 / 146	1 / 25	8.75 / 222	15 / 6.8

Dimensions and weights are for references only. Contact Hayward for certified drawings.



# Y Strainers

## Dimensional Drawings

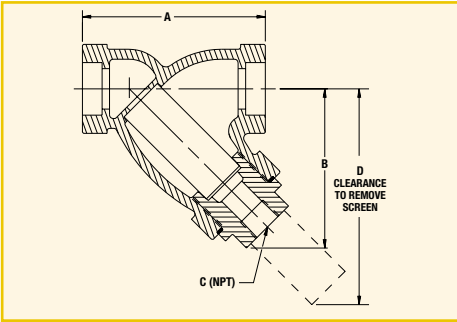

Typical Solder End Y Strainer

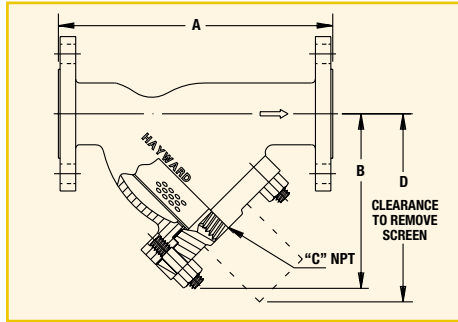

Typical Flanged Y Strainer

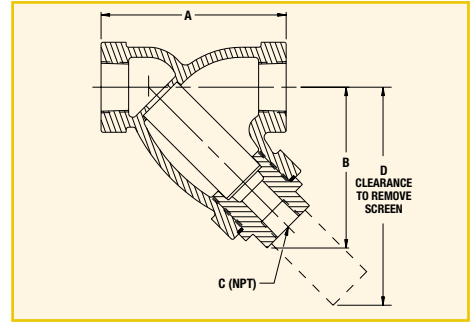

Typical Threaded Y Strainer

### Threaded Cast Iron – 250 lb (in / mm)

Size	A	B	C (Nom.)	D	Wt (lb / kg)
1/4	3.19 / 81	2.00 / 51	1/4 / 7	3.50 / 89	2 / 0.9
3/8	3.19 / 81	2.00 / 51	1/4 / 7	3.50 / 89	2 / 0.9
1/2	3.19 / 81	2.00 / 51	1/4 / 7	3.50 / 89	2 / 0.9
3/4	3.75 / 95	2.44 / 62	3/8 / 10	3.75 / 95	2.5 / 1.1
1	4.00 / 102	2.31 / 59	3/8 / 10	3.75 / 95	3 / 1.4
1-1/4	5.00 / 125	3.38 / 86	3/4 / 20	5.50 / 140	5 / 2.3
1-1/2	5.75 / 146	3.88 / 99	3/4 / 20	6.00 / 152	8 / 3.6
2	7.00 / 178	4.75 / 121	1 / 25	8.75 / 222	12 / 5.4
2-1/2	9.25 / 235	5.88 / 149	1-1/2 / 40	10.50 / 267	22 / 10
3	10.00 / 254	6.00 / 152	1-1/2 / 40	10.50 / 267	30 / 13.6

### Threaded Bronze – 150 lb (in / mm)

Size	A	B	C	D	Wt (lb / kg)
1/4	2.62 / 66	1.88 / 48	1/4 / 7	3.50 / 89	.50 / .20
3/8	2.62 / 66	1.88 / 48	1/4 / 7	3.50 / 89	.50 / .20
1/2	3.13 / 80	2.31 / 58	1/4 / 7	3.75 / 95	.70 / .30
3/4	3.43 / 87	2.38 / 60	3/8 / 10	3.75 / 95	.90 / .40
1	4.06 / 104	2.81 / 72	3/8 / 10	4.50 / 114	1.40 / .60
1-1/4	4.88 / 124	3.25 / 82	3/8 / 10	5.50 / 140	2.40 / 1.10
1-1/2	5.62 / 142	3.75 / 95	1/2 / 15	6.00 / 152	3.30 / 1.50
2	6.69 / 170	4.75 / 120	1/2 / 15	8.75 / 222	5.30 / 2.40
2-1/2	8.39 / 213	5.83 / 148	1 / 25	10.50 / 267	9.20 / 4.20
3	9.06 / 230	6.69 / 170	1-1/4 / 32	11.00 / 279	13.40 / 6.10

### Flanged Cast Iron – 125 lb (in / mm)

Size	A	B	C (Nom.)	D	Wt (lb / kg)
2	7.88 / 200	5.25 / 133	1/2 / 15	7.00 / 178	18 / 8.2
2-1/2	10.00 / 254	6.50 / 165	1 / 25	9.75 / 249	28 / 12.7
3	10.12 / 257	7.00 / 178	1 / 25	10.00 / 254	34 / 15.4
4	12.13 / 308	8.25 / 210	1-1/2 / 40	12.00 / 305	60 / 27.2
5	15.63 / 397	11.25 / 286	2 / 50	17.00 / 432	95 / 43.1
6	18.50 / 470	13.50 / 343	2 / 50	20.00 / 508	135 / 61.2
8	21.63 / 549	15.50 / 394	2 / 50	22.75 / 578	250 / 113.4
10	25.75 / 654	18.50 / 470	2 / 50	28.00 / 711	370 / 167.8

### Solder Weld End Bronze – 150 lb (in / mm)

Size	A	B	C	D	Wt (lb / kg)
1/4	3.38 / 86	1.88 / 48	1/4 / 7	3.50 / 89	.50 / .20
3/8	3.38 / 86	1.88 / 48	1/4 / 7	3.50 / 89	.50 / .20
1/2	3.19 / 81	2.31 / 58	1/4 / 7	3.75 / 95	.70 / .30
3/4	3.62 / 92	2.38 / 60	3/8 / 10	3.75 / 95	.90 / .40
1	4.25 / 108	2.81 / 72	3/8 / 10	4.50 / 114	1.40 / .60
1-1/4	5.12 / 130	3.25 / 82	3/8 / 10	5.50 / 140	2.40 / 1.10
1-1/2	5.94 / 150	3.75 / 95	1/2 / 15	6.00 / 152	3.30 / 1.50
2	7.44 / 188	4.75 / 120	1/2 / 15	8.75 / 222	5.30 / 2.40
2-1/2	8.25 / 210	5.81 / 148	1 / 25	10.50 / 267	9.20 / 4.20
3	9.06 / 230	6.69 / 170	1-1/4 / 32	11.00 / 279	13.40 / 6.10

### Flanged Cast Iron – 250 lb (in / mm)

Size	A	B	C (Nom.)	D	Wt (lb / kg)
2	8.62 / 219	6.00 / 152	1/2 / 15	9.00 / 229	25 / 11.3
2-1/2	10.62 / 270	7.38 / 187	1 / 25	11.00 / 279	32 / 14.5
3	12.00 / 305	8.38 / 213	1 / 25	12.50 / 318	40 / 18.1
4	14.50 / 368	10.00 / 254	1-1/2 / 40	15.00 / 381	74 / 33.6
5	16.38 / 416	11.38 / 289	2 / 50	17.00 / 432	122 / 55.3
6	19.31 / 490	13.38 / 340	2 / 50	20.00 / 508	168 / 76.2
8	23.38 / 594	16.13 / 410	2 / 50	24.13 / 613	300 / 136.1
10	27.38 / 695	19.00 / 483	2 / 50	28.50 / 724	431 / 195.5

### Flanged Bronze – 150 lb (in / mm)

Size	A	B	C	D	Wt (lb / kg)
2	7.88 / 200	5.25 / 133	1/2 / 15	7.00 / 178	17 / 7.70
2-1/2	10.00 / 254	6.50 / 165	1 / 25	9.75 / 248	28 / 12.70
3	10.12 / 257	7.00 / 178	1 / 25	10.00 / 254	34 / 15.40
4	12.13 / 308	8.25 / 209	1-1/2 / 40	12.00 / 305	56 / 25.40
5	15.62 / 397	11.25 / 286	2 / 50	17.00 / 432	91 / 41.30
6	18.50 / 470	13.50 / 343	2 / 50	20.00 / 508	131 / 59.40

### Typical Perforations (Shown Actual Size)

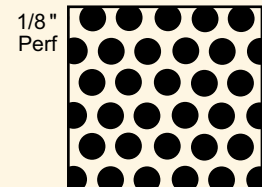
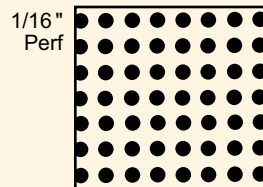
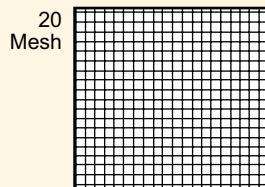

# Y Strainers



## Water Pressure Drops

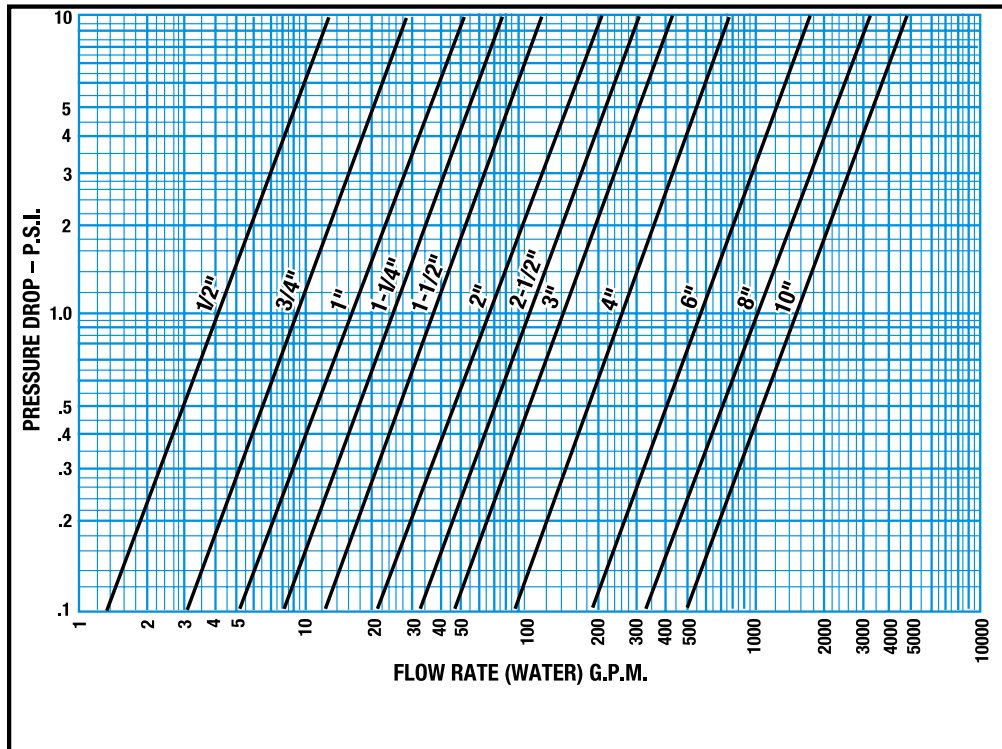

## Calculating Saturated Steam Pressure Drop

### Example:

Pressure = 300 psig

Flow Rate = 20,000 lb/hr

Strainer Size = 4 inches

1. Locate steam flow on Scale A.
2. Follow vertical line to required pressure.
3. Follow horizontal line to strainer size.
4. Follow vertical line downward and read pressure drop on Scale C.
5. Pressure drop equals 1.25 psi.

## Calculating Superheated Steam Pressure Drop

### Example:

Pressure = 300 psig

Flow Rate = 18,000 lb/hr

Strainer Size = 4 inches

1. Locate steam flow on Scale B.
2. Follow horizontal line to superheat.
3. Follow vertical line to pressure.
4. Follow horizontal line to strainer size.
5. Follow vertical line downward and read pressure drop on Scale C.
6. Pressure drop equals 1.25 psi.

**Note:** Use the superheat temperature value above the saturated steam temperature to obtain the point on this graph.

## Steam Pressure Drops

