



Form S70-400 IOM (MAR 2006)

**INSTALLATION - OPERATION - MAINTENANCE**

File: SERVICE MANUAL - Section 70  
Replaces: S70-400 IOM (AUG 2001)  
Dist: 3, 3a, 3b, 3c

# RXF

## ROTARY SCREW COMPRESSOR UNITS

MODELS 12 – 101



**THIS MANUAL CONTAINS RIGGING, ASSEMBLY, START-UP, AND MAINTENANCE INSTRUCTIONS. READ THOROUGHLY BEFORE BEGINNING INSTALLATION. FAILURE TO FOLLOW THESE INSTRUCTIONS COULD RESULT IN DAMAGE OR IMPROPER OPERATION OF THE UNIT.**

Please check [www.frickcold.com](http://www.frickcold.com) for the latest version of this publication.



**TABLE OF CONTENTS**

PREFACE .....3  
 DESIGN LIMITATIONS .....3  
 JOB INSPECTION.....3  
 TRANSIT DAMAGE CLAIMS .....3  
 COMPRESSOR and UNIT IDENTIFICATION .....3

**INSTALLATION**

FOUNDATION .....4  
 HANDLING and MOVING.....4  
 SKID REMOVAL .....5  
 COMPRESSOR/MOTOR COUPLINGS .....5  
 CH COUPLING.....5  
 HOLDING CHARGE and STORAGE .....5  
 COMPRESSOR OIL.....6  
 OIL CHARGE .....6  
 OIL HEATER.....6  
 OIL FILTER(S).....6  
 THERMOSYPHON OIL COOLING .....6  
 LIQUID INJECTION OIL COOLING .....8  
 DUAL DIP TUBE METHOD .....8  
 WATER-COOLED OIL COOLING .....8  
 ECONOMIZER - HIGH STAGE (OPTIONAL).....9  
 ELECTRICAL .....10  
 MOTOR STARTER PACKAGE .....10  
 MINIMUM BURDEN RATINGS.....11  
 CONTROL POWER REGULATOR.....11  
 BATTERY BACKUP .....11

**OPERATION**

OPERATION and START-UP INSTRUCTIONS .....12  
 RXF COMPRESSOR .....12  
 COMPRESSOR LUBRICATION SYSTEM .....12  
 NO PUMP OIL SYSTEM .....12  
 COLD-START SYSTEM .....12  
 DEMAND PUMP OIL SYSTEM.....13  
 COMPRESSOR OIL SEPARATION SYSTEM.....13  
 COMPRESSOR HYDRAULIC SYSTEM .....13  
 CAPACITY CONTROL.....13  
 VOLUMIZER® II Vi CONTROL.....14  
 COMPRESSOR OIL COOLING SYSTEMS .....14  
 SINGLE-PORT LIQUID INJECTION .....14  
 DUAL-PORT LIQUID INJECTION .....14  
 QUANTUM™LX EZ-COOL™ LIQUIDINJECTION  
 ADJUSTMENT PROCEDURE .....15  
 DANFOSS LIQUID INJECTION VALVE.....16  
 HANSEN LIQUID INJECTION VALVE.....19  
 INITIAL START-UP PROCEDURE .....20  
 NORMAL START-UP PROCEDURE .....20  
 RESTARTING COMPRESSOR .....20

**MAINTENANCE**

NORMAL MAINTENANCE OPERATIONS .....21  
 GENERAL MAINTENANCE .....21  
 COMPRESSOR SHUTDOWN and START-UP.....21  
 COMPRESSOR/MOTOR SERVICING .....21  
 GENERAL INSTRUCTIONS FOR REPLACING  
 COMPRESSOR UNIT COMPONENTS .....22  
 OIL FILTER, SPIN-ON (RXF 12 – 50) .....22  
 OIL FILTER, SINGLE ELEMENT (58 – 101) .....22  
 COALESCER OIL RETURN STRAINER .....23  
 LIQUID INJECTION STRAINER .....23  
 OIL PUMP STRAINER (Optional) .....23  
 SUCTION CHECK VALVE BYPASS .....23  
 COALESCER FILTER ELEMENT .....24  
 CHANGING OIL .....24  
 SUCTION STRAINER CLEANING PROCEDURE .....24  
 DEMAND PUMP DISASSEMBLY .....25  
 DEMAND PUMP ASSEMBLY .....26  
 TROUBLESHOOTING THE DEMAND PUMP.....27  
 RECOMMENDED MAINTENANCE PROGRAM.....28  
 VIBRATION ANALYSIS .....28  
 OIL QUALITY and ANALYSIS .....28  
 MOTOR BEARINGS.....29  
 OPERATING LOG .....29  
 TROUBLESHOOTING GUIDE .....29  
 MAINTENANCE SCHEDULE.....29  
 ABNORMAL OPERATION  
     ANALYSIS and CORRECTION.....30  
 PRESSURE TRANSDUCERS - TESTING .....30  
 PRESSURE TRANSDUCERS REPLACEMENT.....31  
 PRESSURE TRANSDUCER CONVERSION DATA .....31  
 SLIDE VALVE TRANSMITTER REPLACEMENT .....32  
 TEMPERATURE SENSOR REPLACEMENT .....32  
 OIL LEVEL TRANSMITTER REPLACEMENT .....32  
 TEMPERATURE and/or PRESSUREADJUSTMENT.....33  
 BARE COMPRESSOR MOUNTING .....33  
 TROUBLESHOOTING THE COMPRESSOR.....33  
     OIL SEPARATOR .....33  
     LIQUID INJECTION OIL COOLING SYSTEM.....34  
     HYDRAULIC SYSTEM.....34  
 COMPRESSOR PORT LOCATIONS .....35  
 P & I DIAGRAMS.....38  
 WIRING HARNESS.....44  
 PROPER INSTALLATION OF ELECTRONIC EQUIPMENT  
     IN AN INDUSTRIAL ENVIRONMENT .....46  
 FORMS.....49  
 INDEX.....55

**SAFETY PRECAUTION DEFINITIONS**



Indicates an imminently hazardous situation which, if not avoided, will result in death or serious injury.



Indicates a potentially hazardous situation or practice which, if not avoided, will result in death or serious injury.



Indicates a potentially hazardous situation or practice which, if not avoided, will result in damage to equipment and/or minor injury.

**NOTE:**

Indicates an operating procedure, practice, etc., or portion thereof which is essential to highlight.

**PREFACE**

This manual has been prepared to acquaint the owner and service person with the **INSTALLATION, OPERATION, and MAINTENANCE** procedures as recommended by Frick for **RXF Rotary Screw Compressor Units**.

It is most important that these units be properly applied to an adequately controlled refrigeration system. Your authorized Frick representative should be consulted for expert guidance in this determination.

Proper performance and continued satisfaction with these units is dependent upon:

**CORRECT INSTALLATION  
PROPER OPERATION  
REGULAR, SYSTEMATIC PLANNED MAINTENANCE**

To ensure correct installation and application, the equipment must be properly selected and connected to a properly designed and installed system. The Engineering plans, piping layouts, etc. must be detailed in accordance with the best practices and local codes, such as those outlined in ASHRAE literature.

A refrigeration compressor is a **VAPOR PUMP**. To be certain that it is not being subjected to liquid refrigerant carryover, it is necessary that refrigerant controls are carefully selected and in good operating condition; the piping is properly sized and traps, if necessary, are correctly arranged; the suction line has an accumulator or slugging protection; that load surges are known and provisions made for control; operating cycles and defrosting periods are reasonable; oil return is controlled; and that high side condenser units control head pressures and temperatures are within system and compressor design limits.

It is recommended that the entering vapor temperature to the compressor be superheated to 10°F above the refrigerant saturation temperature to ensure that all refrigerant at the compressor suction is in the vapor state.

**DESIGN LIMITATIONS**

The compressor units are designed for operation within the pressure and temperature limits as shown in Frick Publication E70-400 SED.

**JOB INSPECTION**

Immediately upon arrival examine all crates, boxes, and exposed compressor and component surfaces for damage. Unpack all items and check against shipping lists for any possible shortage. Examine all items for damage in transit.

**TRANSIT DAMAGE CLAIMS**

All claims must be made by consignee. This is an ICC requirement. Request immediate inspection by the agent of the carrier and be sure the proper claim forms are executed.

Contact Frick, Sales Administration Department, in Waynesboro, PA to report damage or shortage claims.

**COMPRESSOR and UNIT IDENTIFICATION**

Each compressor unit has 2 identification data plates.

The compressor data plate containing compressor model and serial number is mounted on the compressor body.

The unit data plate containing unit model, serial number and Frick sales order number is mounted on the control panel support bracket.

**NOTE: When inquiring about the compressor or unit, or ordering repair parts, provide the MODEL, SERIAL, and FRICK SALES ORDER NUMBERS from these data plates.**

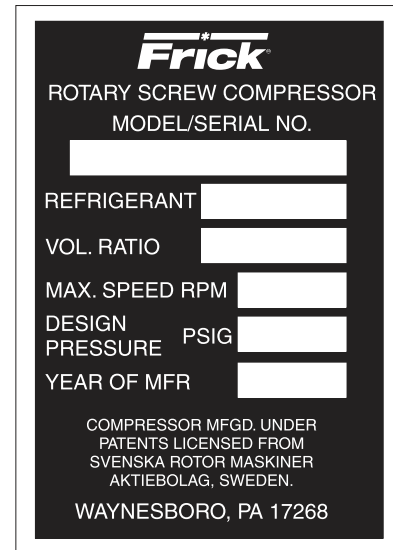

**COMPRESSOR DATA PLATE**

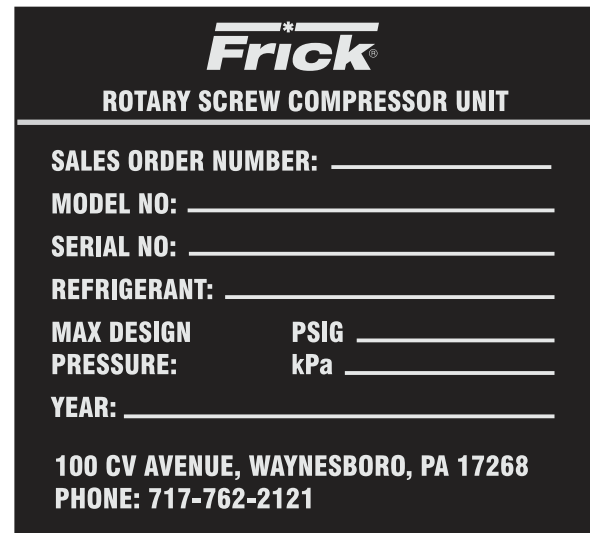

**UNIT DATA PLATE**

## Installation

### FOUNDATION

**NOTE: Allow space for servicing both ends of the unit. A minimum of 24 inches is recommended.**

The first requirement of the compressor foundation is that it must be able to support the weight of the compressor package including coolers, oil, and refrigerant charge. Screw compressors are capable of converting large quantities of shaft power into gas compression in a relatively small space and a mass is required to effectively dampen these relatively high frequency vibrations.

Firmly anchoring the compressor package to a suitable foundation by proper application of grout and elimination of piping stress imposed on the compressor is the best insurance for a trouble free installation. Use only the certified general arrangement drawings from Frick® to determine the mounting foot locations and to allow for recommended clearances around the unit for ease of operation and servicing. Foundations must be in compliance with local building codes and materials should be of industrial quality.

The floor shall be a minimum of 6 inches of reinforced concrete and housekeeping pads are recommended. Anchor bolts are required to firmly tie the unit to the floor. Once the unit is rigged into place (See HANDLING and MOVING), the feet must then be shimmed in order to level the unit. The shims should be placed to position the feet roughly one inch above the housekeeping pad to allow room for grouting. An expansion-type epoxy grout must be worked under all areas of the base with no voids and be allowed to settle with a slight outward slope so oil and water can run off of the base.

When installing on a steel base, the following guidelines should be implemented to properly design the system base:

1. Use I-beams in the skid where the screw compressor will be attached to the system base. They shall run parallel to the package feet and support the feet for their full length.
2. The compressor unit feet shall be continuously welded to the system base at all points of contact, or bolted.
3. The compressor unit shall not be mounted on vibration isolators in order to hold down package vibration levels.
4. The customer's foundation for the system base shall fully support the system base under all areas, but most certainly under the I-beams that support the compressor package.

When installing on the upper floors of buildings, extra precautions should be taken to prevent normal package vibration from being transferred to the building structure. It may be necessary to use rubber or spring isolators, or a combination of both, to prevent the transmission of compressor vibration directly to the structure. However, this may increase package vibration levels because the compressor is not in contact with any damping mass. The mounting and support of suction and discharge lines is also very important. Rubber or spring pipe supports may be required to avoid exciting the building structure at any pipe supports close to the compressor package. It is best to employ a vibration expert in the design of a proper mounting arrangement.

In any screw compressor installation, suction and discharge lines shall be supported in pipe hangers (preferably within 2 feet of vertical pipe run) so that the lines won't move if disconnected from the compressor. See table for Allowable Flange Loads.

NOZ. SIZE NPS	ALLOWABLE FLANGE LOADS					
	MOMENTS (ft-lbf)			LOAD (lbf)		
	AXIAL	VERT.	LAT.	AXIAL	VERT.	LAT.
	M <sub>R</sub>	M <sub>C</sub>	M <sub>L</sub>	P	V <sub>C</sub>	V <sub>L</sub>
1	25	25	25	50	50	50
1.25	25	25	25	50	50	50
1.5	50	40	40	100	75	75
2	100	70	70	150	125	125
3	250	175	175	225	250	250
4	400	200	200	300	400	400
5	425	400	400	400	450	450
6	1,000	750	750	650	650	650
8	1,500	1,000	1,000	1,500	900	900
10	1,500	1,200	1,200	1,500	1,200	1,200
12	1,500	1,500	1,500	1,500	1,500	1,500
14	2,000	1,800	1,800	1,700	2,000	2,000

Proper foundations and proper installation methods are vital; and even then, sound attenuation or noise curtains may be required to reduce noise to desired levels.

For more detailed information on Screw Compressor Foundations, please request Frick publication S70-210 IB.

### HANDLING and MOVING

RXF 12–50 units can be moved with a forklift or with rigging and a crane. The recommended method is to insert lengths of 2" pipe through the base tubing (see Figure 1 below).



**CAUTION** Spreader bars should be used on both the length and width of the package to prevent bending oil lines and damage to the package. CAUTION must also be used in locating the lifting ring. Appropriate adjustment in the lifting point should be made to compensate for motor weight. Adjustment of the lifting point must also be made for any additions to the standard package such as an external oil cooler, etc., as the center of balance will be effected.

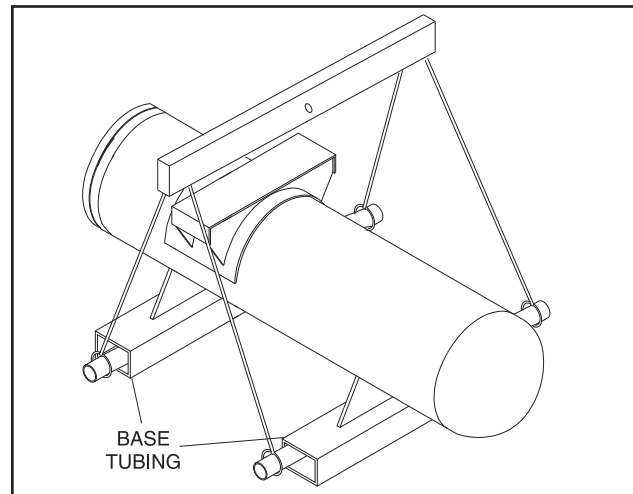

Figure 1 - RXF 12 – 50

The unit can be moved with a forklift by forking through the base tubing. **NEVER MOVE THE UNIT BY PUSHING OR FORKING AGAINST THE SEPARATOR SHELL OR ITS MOUNTING SUPPORTS.**

RXF 58 – 101 units can be moved with rigging, using a crane or forklift by hooking into three lifting points on the oil separator. See Figure 1a.

**CAUTION** Spreader bars may be required on both the length and width of the package to prevent bending oil lines and damage to the package. CAUTION must also be used in locating the lifting ring. Appropriate adjustment in the lifting point should be made to compensate for motor weight. Adjustment of the lifting point must also be made for any additions to the standard package such as an external oil cooler, etc., as the center of balance will be affected.

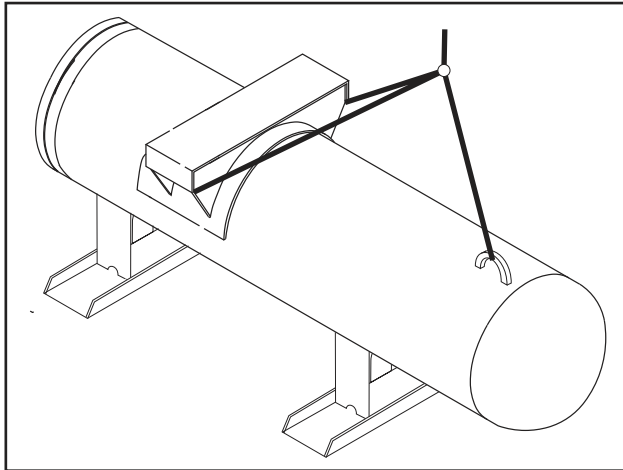

Figure 1a - RXF 58 – 101

The unit can be moved with a forklift by forking **under the skid**, or it can be skidded into place with pinch bars by pushing against the skid. **NEVER MOVE THE UNIT BY PUSHING OR FORKING AGAINST THE SEPARATOR SHELL OR ITS MOUNTING SUPPORTS.**

**SKID REMOVAL**

**CAUTION** This screw compressor package may be top-heavy. Use caution to prevent unit from turning over.

If the unit is rigged into place, the skid can be removed by taking off the nuts and bolts that are fastening the unit mounting supports to the skid before lowering the unit onto the mounting surface.

If the unit is skidded into place, remove the cross members from the skid and remove the nuts anchoring the unit to the skid. Using a 10-ton jack under the separator raise the unit at the compressor end until it clears the two mounting bolts. Spread the skid to clear the unit mounting support, then lower the unit to the surface. Repeat procedure on opposite end.

**COMPRESSOR/MOTOR COUPLINGS**

RXF units are arranged for direct motor drive and include a flexible drive coupling to connect the compressor to the motor.

**CH COUPLING**

The T. B. Woods Elastomeric Type CH Coupling is used in most applications. This coupling consists of two drive hubs and a gear-type Hytrel or EDPM and neoprene drive spacer. The split hub is clamped to the shaft by tightening the clamp screws. Torque is transmitted from the motor through the elastomeric gear which floats freely between the hubs. Because of the use of the motor/compressor adapter housing on the RXF, no field alignment is necessary.

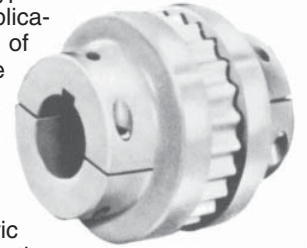

**WARNING** It is mandatory that the coupling center be removed and the direction of motor rotation be confirmed before running the compressor. Proper rotation of the compressor shaft is clockwise looking at the end of the compressor shaft. Failure to follow this step could result in backward compressor rotation which can cause compressor failure or explosion of the suction housing.

1. Inspect the shaft of the motor and compressor to ensure that no nicks, grease, or foreign matter is present.
2. Inspect the bores in the coupling hubs to make sure that they are free of burrs, dirt, and grit.
3. Check that the keys fit the hubs and shafts properly.
4. Slide one hub onto each shaft as far as possible. It may be necessary to use a screwdriver as a wedge in the slot to open the bore before the hubs will slide on the shafts.
5. Hold the elastomeric gear between the hubs and slide both hubs onto the gear to fully engage the mating teeth. Center the gear and hub assembly so there is equal engagement on both shafts. Adjust the space between hubs as specified in the CH Coupling Data Table below.
6. Torque the clamping bolts in both hubs to the torque value given in the CH Data Table. **DO NOT USE ANY LUBRICANT ON THESE BOLTS.**

**HOLDING CHARGE and STORAGE**

Each compressor unit is pressure and leak tested at the Frick factory and then thoroughly evacuated and charged with dry nitrogen to ensure the integrity of the unit during shipping and short term storage prior to installation.

**NOTE: Care must be taken when entering the unit to ensure that the nitrogen charge is safely released.**

**CH COUPLING DATA TABLE**

Coupling Hub																	
CH Series	Between Shaft Spacing				Shaft Engagement				Face Spacing		Clamp Bolt			Keyway			
	Min.		Max.		Min.		Max.				Torque (Dry)		Size	Setscrew Torque		Size UNC	
Size	In.	mm	In.	mm	In.	mm	In.	mm	In.	mm	Ft-Lb	Nm		Ft-Lb	Nm		
6	2	50.8	2 <sup>3</sup> / <sub>4</sub>	69.9	1	25.4	1 <sup>5</sup> / <sub>16</sub>	49.2	7/8	22.2	15	20.3	1/4-20 UNC	13	17.6	5/16-18	
7	2 <sup>5</sup> / <sub>16</sub>	58.7	3 <sup>7</sup> / <sub>16</sub>	87.3	1	25.4	2 <sup>3</sup> / <sub>16</sub>	55.6	1 <sup>1</sup> / <sub>16</sub>	27	30	40.7	5/16-24 UNF	13	17.6	5/16-18	
8	2 <sup>9</sup> / <sub>16</sub>	65.1	4	101.6	1 <sup>1</sup> / <sub>16</sub>	27	2 <sup>1</sup> / <sub>2</sub>	63.5	1 <sup>1</sup> / <sub>8</sub>	28.6	55	74.6	3/8-24 UNF	13	17.6	5/16-18	
9	3 <sup>1</sup> / <sub>16</sub>	77.8	4 <sup>5</sup> / <sub>8</sub>	117.5	1 <sup>7</sup> / <sub>16</sub>	36.5	3	76.2	1 <sup>7</sup> / <sub>16</sub>	36.5	55	74.6	3/8-24 UNF	13	17.6	5/16-18	
10	3 <sup>3</sup> / <sub>16</sub>	90.5	5 <sup>1</sup> / <sub>4</sub>	133.4	1 <sup>11</sup> / <sub>16</sub>	42.9	3 <sup>1</sup> / <sub>2</sub>	88.9	1 <sup>11</sup> / <sub>16</sub>	42.9	130	176.3	1/2-20 UNF	13	17.6	5/16-18	

**WARNING**

Holding charge shipping gauges on separator and external oil cooler are rated for 30 PSIG and are for

checking the shipping charge only. They must be removed before pressure testing the system and before charging the system with refrigerant. Failure to remove these gauges may result in catastrophic failure of the gauge and uncontrolled release of refrigerant resulting in serious injury or death.

All units must be kept in a clean, dry location to prevent corrosion damage. Reasonable consideration must be given to proper care for the solid state components of the microprocessor.

Units which will be stored for more than two months must have the nitrogen charge checked periodically. Contact Frick for long term storage procedure.

**COMPRESSOR OIL**

**WARNING**

DO NOT MIX OILS of different brands, manufacturers, or types. Mixing of oils may cause excessive

oil foaming, nuisance oil level cutouts, oil pressure loss, gas or oil leakage and catastrophic compressor failure.

**CAUTION**

Use of oils other than Frick may cause warranty claim to be denied.

The oil charge shipped with the unit is the best suited lubricant for the conditions specified at the time of purchase. If there is any doubt due to the refrigerant, operating pressures, or temperatures; refer to Frick Pub. E160-802 SPC for guidance.

**OIL CHARGE**

The normal charging level is midway in the top sight glass located midway along the oil separator shell. Normal operating level is between the top sight glass and bottom sight glass. Oil charge quantities are as follows:

RXF MODEL	BASIC CHARGE* (gal.)
12 – 19	10
24 – 50	11
58, 68	25
85, 101	36

*ADDITIONAL FOR OIL COOLER				
12 – 50 (Flat Plate)		58 – 101 (Plate & Shell)		
SIZE	GAL.	DIA.	PLATES	GAL.
5" x 20"	1/2	14"	66	2
10" x 20"	1	14"	116	3 1/2

Add oil by attaching the end of a suitable pressure-type hose to the oil charging valve, located towards the top of the oil separator in the middle of the vessel. Using a pressure-type pump and the recommended FRICK Oil, open the charging valve and pump oil into the separator.

Oil distillers and similar equipment which trap oil must be filled prior to unit operation to normal design outlet levels. The same pump used to charge the unit may be used for filling these auxiliary oil reservoirs.

The sight glass located near the bottom of the separator shell at the discharge end should remain empty when the unit is

in operation. The presence of oil in this end of the vessel during operation indicates liquid carryover or malfunction of the oil return.

**OIL HEATER**

Standard units are equipped with 500 watt oil heaters, which provide sufficient heat to maintain the oil temperature for most indoor applications during shutdown cycles and to permit safe start-up. RXF 12–50 use one heater while models 58–101 use two. Should additional heating capacity be required because of an unusual environmental condition, contact Frick . The heater is energized only when the unit is not in operation.

**WARNING**

Do not energize the heater when there is no oil in the unit, otherwise the heater will burn out. The oil heater

will be energized whenever 120 volt control power is applied to the unit and the compressor is not running, unless the 16 amp circuit breaker in micro enclosure is turned off (or 15 amp fuse (1FU) in the Plus panel is removed).

**OIL FILTER(S)**

**CAUTION**

Use of filter elements other than Frick may cause warranty claim to be denied.

The oil filter(s) and coalescer filter element(s) shipped with the unit are best suited to ensure proper filtration and operation of the system.

**THERMOSYPHON OIL COOLING**

Thermosyphon oil cooling is an economical, effective method for cooling oil on screw compressor units. Thermosyphon cooling utilizes liquid refrigerant at condenser pressure and temperature which is partially vaporized at the condenser temperature in a shell and tube or plate-type vessel, cooling the oil. The vapor, at condensing pressure, is vented to the condenser inlet and reliquified. This method is the most cost effective of all currently applied cooling systems since no compressor capacity loss or compressor power penalties are incurred. The vapor from the cooler need only be condensed, not compressed. Refrigerant flow to the cooler is automatic, driven by the thermosyphon principle, and cooling flow increases as the oil inlet temperature rises.

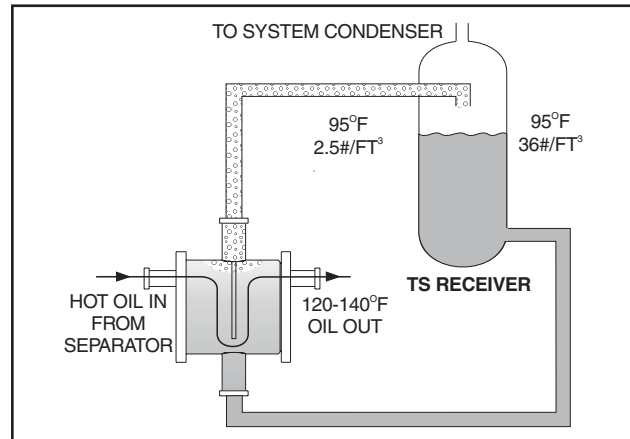
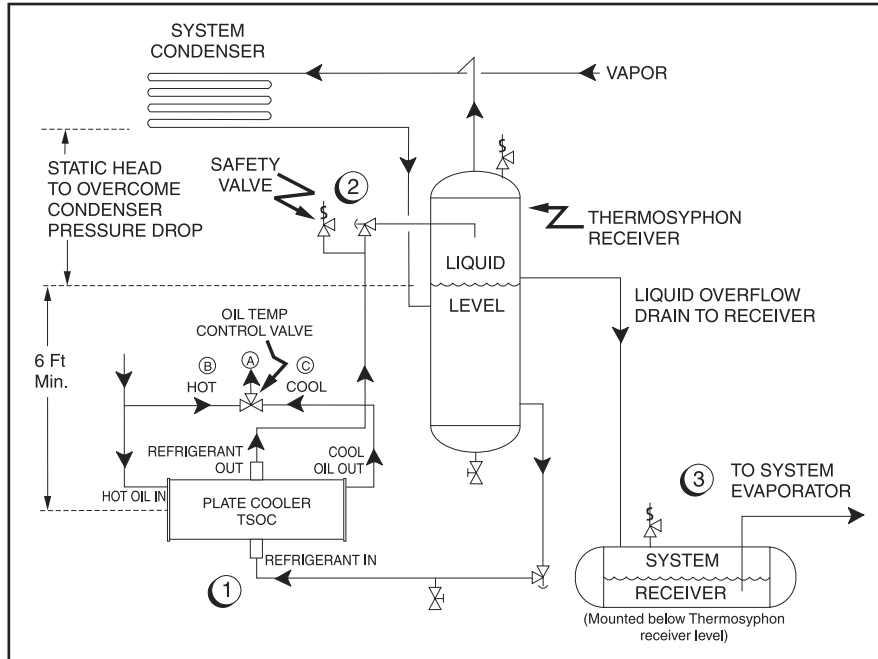

Figure 2



1. Thermosyphon oil cooler is supplied with oil side piped to the compressor unit and stub ends supplied on the refrigerant side.
2. A refrigerant-side safety valve is required when refrigerant isolation valves are installed between the cooler and thermosyphon receiver. If no valves are used between the cooler and TSOC receiver, the safety valve on the TSOC receiver must be sized to handle the volume of both vessels. Then, the safety valve on the cooler vent (liquid refrigerant side) can be eliminated.
3. System receiver must be mounted below thermosyphon receiver level in this arrangement.

**Figure 3**

**EQUIPMENT:** The basic equipment required for a thermosyphon system consists of:

1. A source of liquid refrigerant at condensing pressure and temperature located in close proximity to the unit to minimize piping pressure drop.

The liquid level in the refrigerant source must be 6 to 8 feet above the center of the oil cooler.

2. A shell and tube or plate-type oil cooler with a minimum 300 psi design working pressure on both the oil and refrigerant sides.

Due to the many variations in refrigeration system design and physical layout, several systems for assuring the above two criteria are possible.

**SYSTEM OPERATION:** Liquid refrigerant fills the cooler tube side up to the Thermosyphon receiver liquid level.

Warm or hot oil (above the liquid temperature) flowing through the cooler will cause some of the refrigerant to boil and vaporize in the tubes. The vapor rises in the return line.

The density of the refrigerant liquid/vapor mixture in the return line is considerably less than the density of the liquid in the supply line. This imbalance provides a differential pressure which sustains a flow condition to the oil cooler. This relationship involves:

1. Liquid height above the cooler.
2. Oil heat of rejection.
3. Cooler size and piping pressure drops.

Current thermosyphon systems are using single-pass oil coolers and flow rates based on 3:1 overfeed.

The liquid/vapor returned from the cooler is separated in the receiver. The vapor is vented to the condenser inlet and need only be reliquified since it is still at condenser pressure.

**INSTALLATION:** The shell and tube or plate-type thermosyphon oil cooler with oil side piping and a thermostatically controlled mixing valve are factory mounted and piped.

The customer must supply and install all the piping and equipment located outside of the shaded area on the piping diagram with consideration given to the following:

1. The refrigerant source, thermosyphon or system receiver, should be in close proximity to the unit to minimize piping pressure drop.
2. The liquid level in the refrigerant source must not be less than 6 feet above the center of the oil cooler.
3. Frick recommends the installation of an angle valve in the piping before the thermosyphon oil cooler to balance the thermosyphon system. Frick also recommends the installation of sight glasses at the TSOC inlet and outlet to aid in troubleshooting. The factory-mounted plate-type thermosyphon oil cooler requires a refrigerant-side drain valve to be provided and installed by the customer.

**FIELD WELDING INSTRUCTIONS:** The following are requirements for welding to the socket weld fittings on FlatPlate brazed-plate heat exchangers:

1. Two-pass welding is required; stagger start/stop region; welding procedure in accordance with ASME Section 9.
2. Welding should occur in two segments, from 6:00 to 12:00. The maximum intersegment temperature should be 350°F. Temperature should be verified with temperature indicating crayon or equivalent.
3. The fitting may be cooled with forced air to reduce the temperature of the fitting to 350°F or lower, prior to welding the second segment.

**TSOC AND WCOC OPTIONAL OIL SIDE SAFETY RELIEF**

- Compressor units with flat plate oil coolers, which have valves in the oil piping to isolate the oil cooler from the oil separator for servicing, may have factory installed piping to relieve the shell side (oil side) safety valve directly into the oil separator, as shown in the P & I diagrams section.

This arrangement uses a special UV stamped safety valve rated for liquid and vapor relief. The safety valve is set to relieve at 75 psi differential.

**CAUTION**

Extra caution should be used when servicing an oil separator with this arrangement. If the oil cooler is

valved off from an oil separator which has been evacuated for servicing, then the oil cooler will relieve into the separator vessel if the 75 psi differential setpoint is exceeded.

The component and piping arrangement shown in Figure 3 is intended only to illustrate the operating principles of thermosyphon oil cooling. Other component layouts may be better suited to a specific installation. Refer to publication E70-900E for additional information on Thermosyphon Oil Cooling.

**LIQUID INJECTION OIL COOLING**

The liquid injection system provided on the unit is self-contained but requires the connection of the liquid line sized as shown in the table.

Liquid line sizes and the additional receiver volume (quantity of refrigerant required for 5 minutes of liquid injection oil cooling) are given in the following table:

REF	RXF MODEL	LIQ. LINE SIZE*		FLOW RATE (lb) 5 MIN	LIQUID VOLUME CU. FT.
		PIPE SCH 80	TUBING OD		
R-717 HIGH STAGE	12	1/2	—	10	.3
	15	1/2	—	12.5	.4
	19	1/2	—	15	.4
	24	1/2	—	20	.6
	30	1/2	—	25	.7
	39	1/2	—	30	.8
	50	3/4	—	40	1.1
	58	3/4	—	47	1.3
	68	3/4	—	55	1.6
	85	3/4	—	70	2.0
101	3/4	—	80	2.3	
R-22 HIGH STAGE	12	3/4	5/8	30	.4
	15	3/4	5/8	37.5	.5
	19	3/4	5/8	45	.6
	24	3/4	7/8	60	.8
	30	3/4	7/8	75	1.0
	39	3/4	7/8	95	1.3
	50	1	1-1/8	125	1.7
	58	1	1-1/8	145	1.9
	68	1	1-1/8	170	2.3
	85	1	1-1/8	210	2.8
101	1	1-1/8	250	3.4	
R-717 BOOSTER	12	1/2	—	2.0	.1
	15	1/2	—	2.5	.1
	19	1/2	—	3.5	.1
	24	1/2	—	4.5	.1
	30	1/2	—	5.5	.2
	39	1/2	—	6.5	.2
	50	1/2	—	8.5	.3
	58	1/2	—	10	.3
	68	1/2	—	12	.3
	85	1/2	—	15	.4
101	1/2	—	18	.5	
R-22 BOOSTER	12	3/4	5/8	6	.1
	15	3/4	5/8	7	.1
	19	3/4	5/8	9	.1
	24	3/4	5/8	12	.2
	30	3/4	5/8	14.5	.2
	39	3/4	5/8	18	.3
	50	3/4	5/8	24	.3
	58	3/4	5/8	28	.4
	68	3/4	5/8	33	.5
	85	3/4	5/8	41	.6
101	3/4	5/8	50	.7	

\* 100 ft. liquid line. For longer runs, increase line size accordingly.

High-stage compressor units may be supplied with single-port (low Vi) or dual-port (low Vi and high Vi), liquid injection oil cooling. Single port will be furnished for low compression ratio

operation and dual port for high compression ratio operation. Booster compressor units use single-port, liquid injection oil cooling due to the typically lower compression ratios.

The control system on high-stage units with dual-port, liquid injection oil cooling switches the liquid refrigerant supply to the high port when the compressor is operating at higher compression ratios (3.5 Vi and above) for best efficiency.

Where low compression ratios (low condensing pressures) are anticipated, thermosyphon or water-cooled oil cooling should be used.

**CAUTION**

It is imperative that an uninterrupted high-pressure liquid refrigerant be provided to the injection system

at all times. Two items of EXTREME IMPORTANCE are the design of the receiver/liquid injection supply and the size of the liquid line. It is recommended that the receiver be oversized sufficiently to retain a 5-minute supply of refrigerant for oil cooling. The evaporator supply must be secondary to this consideration. Failure to follow these requirements causes wire draw which can result in damage to the expansion valve, loss of oil cooling, and intermittent oil cooling. One method of accomplishing this is described below.

**DUAL DIP TUBE METHOD**

The dual dip tube method uses two dip tubes in the receiver. The liquid injection tube is below the evaporator tube to assure continued oil cooling when the receiver level is low. See Figure 4.

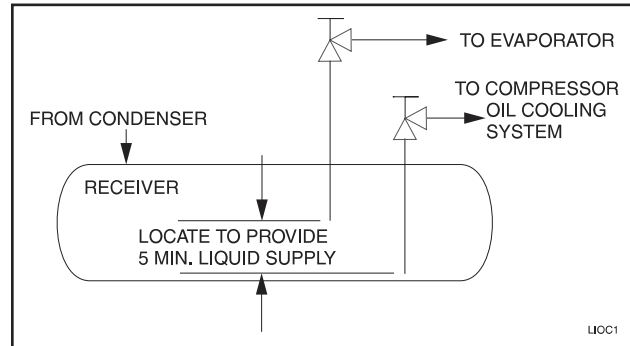

Figure 4

**WATER-COOLED OIL COOLING**

The flat plate or plate and shell-type water-cooled oil cooler is mounted on the unit complete with all oil piping. The customer must supply adequate water to the oil cooler.

Frick recommends a closed-loop system for the waterside of the oil cooler. Careful attention to water treatment is essential to ensure adequate life of the cooler if cooling tower water is used. **It is imperative that the condition of cooling water and closed-loop fluids be analyzed regularly and as necessary and maintained at a pH of 7.4, but not less than 6.0 for proper heat exchanger life.** After initial start-up of the compressor package, the strainer at the inlet of the oil cooler should be cleaned several times in the first 24 hours of operation.

In some applications, the plate and shell oil cooler may be subjected to severe water conditions, including high temperature and/or hard water conditions. This causes accelerated scaling rates which will penalize the performance of

the heat exchanger. A chemical cleaning process will extend the life of the Plate and Shell heat exchanger. It is important to establish regular cleaning schedules.

**Cleaning:** A 3% solution of Phosphoric or Oxalic Acid is recommended. Other cleaning solutions can be obtained from your local distributor, but they must be suitable for stainless steel. The oil cooler may be cleaned in place by back flushing with recommended solution for approximately 30 minutes. After back flushing, rinse the heat exchanger with fresh water to remove any remaining cleaning solution.

**OIL COOLER DATA TABLE**

TYPICAL COOLER		CONNECTION SIZE
RXF 12 – 50	5" x 20"	1½"
RXF 58 – 101	14" X 66 Plates	2"

**ECONOMIZER - HIGH STAGE (OPTIONAL)**

The economizer option provides an increase in system capacity and efficiency by subcooling liquid from the condenser through a heat exchanger or flash tank before it goes to the evaporator. The subcooling is provided by flashing liquid in the economizer cooler to an intermediate pressure level. The intermediate pressure is provided by a port located part way down the compression process on the screw compressor.

As the screw compressor unloads, the economizer port will drop in pressure level, eventually being fully open to suction. Because of this, an output from the microprocessor is generally used to turn off the supply of flashing liquid on a shell and coil or DX economizer when the capacity falls below approximately 45%-60% (85%-90% slide valve position). This is done to improve compressor operating efficiency. Please note however that shell and coil and DX economizers can be used at low compressor capacities in cases where efficiency is not as important as ensuring that the liquid supply is subcooled. In such cases, the economizer liquid solenoid can be left open whenever the compressor is running.

Due to the tendency of the port pressure to fall with decreasing compressor capacity, a back-pressure regulator valve (BPR) is generally required on a flash economizer system (Figure 7) in order to maintain some preset pressure difference between the subcooled liquid in the flash vessel and the evaporators. If the back-pressure regulator valve is not used on a flash economizer, it is possible that no pressure difference will exist to drive liquid from the flash vessel to the evaporators, since the flash vessel will be at suction pressure. In cases where wide swings in pressure are anticipated in the flash economizer vessel, it may be necessary to add an outlet pressure regulator to the flash vessel outlet to avoid overpressurizing the economizer port, which could result in motor overload. Example: A system feeding liquid to the flash vessel in batches.

The recommended economizer systems are shown in Figures 5 – 8. Notice that in all systems there must be a strainer and a check valve between the economizer vessel and the economizer port on the compressor. The strainer prevents dirt from passing into the compressor and the check valve prevents oil from flowing from the compressor unit to the economizer vessel during shutdown.

**CAUTION** Other than the isolation valve needed for strainer cleaning, it is essential that the strainer be the last device in the economizer line before the compressor. Also, piston-type check valves are recommended for installation in the economizer line, as opposed to disc-type check valves. The latter are more prone to gas-pulsation-induced failure. The isolation and check valves and strainer should be located as closely as possible to the compressor, preferably within a few feet.

For refrigeration plants employing multiple compressors on a common economizing vessel, regardless of economizer type, each compressor must have a back-pressure regulating valve in order to balance the economizer load, or gas

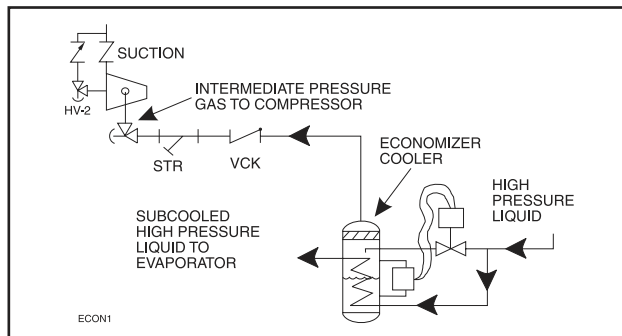

**Figure 5 - Shell And Coil Economizer System**

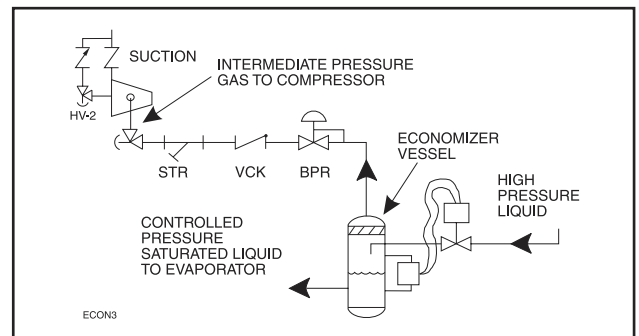

**Figure 7- Flash Economizer System**

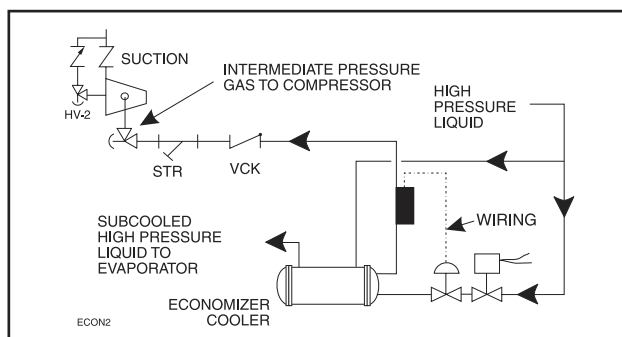

**Figure 6 - Direct Expansion Economizer System**

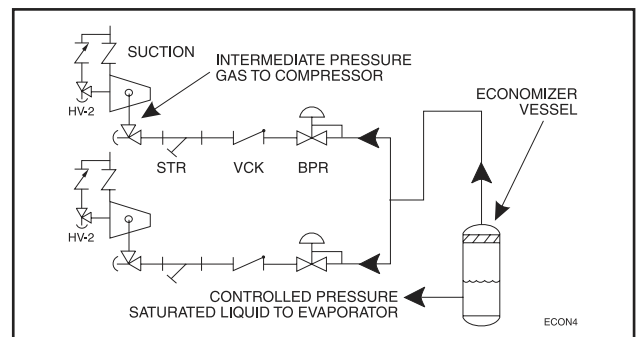

**Figure 8 - Multiple Compressor Economizer System**

flow, between compressors. The problem of balancing load becomes most important when one or more compressors run at partial load, exposing the economizer port to suction pressure. In the case of a flash vessel, there is no need for the redundancy of a back-pressure regulating valve on the vessel and each of the multiple compressors. Omit the BPR valve on the flash economizer vessel and use one on each compressor, as shown in Figure 8.

## ELECTRICAL

**NOTE: Before beginning electrical installation, read the instructions in the section "Proper Installation of Electronic Equipment" at the back of this manual.**

RXF units are supplied with a **QUANTUM™LX** control system. Care must be taken that the controls are not exposed to physical damage during handling, storage, and installation. The single-box control door must be kept tightly closed to prevent moisture and foreign matter from entry.

 **CAUTION** All customer connections are made in the Quantum™LX control panel(s) mounted on the unit. This is (these are) the ONLY electrical enclosure(s) and should be kept tightly closed whenever work is not being done inside.

## VOLTAGE PROTECTION

Frick® does not advise nor support the use of UPS power systems in front of the Quantum™LX panel. With a UPS power system providing shutdown protection for the Quantum™LX, the panel may not see the loss of the 3-phase voltage on the motor because the UPS could prevent the motor starter contactor from dropping out. With the starter contactor still energized, the compressor auxiliary will continue to feed an "Okay" signal to the panel. This will allow the motor to be subjected to a fault condition on the 3-phase bus. Some fault scenarios are:

1. The 3-phase bus has power "on" and "off" in a continuous cyclic manner which may cause the motor to overheat due to repeated excessive in-rush currents.
2. Motor cycling may damage the coupling or cause other mechanical damage due to the repeated high torque motor "bumps".
3. Prolonged low voltage may cause the motor to stall and overheat before the motor contactor is manually turned off.

Under normal conditions, the loss of 3-phase power will shut down the Quantum™LX panel, and it will restart upon power return. If the panel was in:

- **Auto** – Compressor motor will return to running as programmed.
- **Remote** – The external controller would reinitialize the panel and proceed to run as required.
- **Manual** – The compressor will have to be restarted manually after the 3-phase bus fault has been cleared.

If the local power distribution system is unstable or prone to problems, there are other recommendations to satisfy these problems. If power spikes or low or high line voltages are the problem, then Frick® recommends the use of a Sola® constant voltage (CV) transformer with a line suppression feature. If

a phase loss occurs, then you will typically get a high motor amp shutdown. If problems continue to exist, then an examination of the plant's power factor may be in order.

Unless careful design failure analysis is considered in the implementation of power systems, the alternative solutions provide a safer and less expensive implementation. In either case, only one Sola® may be used per compressor. Each compressor needs to be individually isolated from each other through a dedicated control transformer. Sharing a common control power source is an invitation for ground loops and the subsequent unexplainable problems.

## MOTOR STARTER PACKAGE

 **CAUTION** When starting at full voltage or across-the-line, a shunting device must be installed or the Analog I/O board in the Quantum™LX panel may be severely damaged at start-up. See Figure 9.

Motor starter and interlock wiring requirements are shown in the diagram, Figure 9. All of the equipment shown is supplied by the installer unless a starter package is purchased separately from Frick. Starter packages should consist of:

1. The compressor motor starter of the specified horsepower and voltage for the starting method specified (across-the-line, autotransformer, wye-delta or solid-state).

**NOTE: If starting methods other than across-the-line are desired, a motor/compressor torque analysis must be done to ensure sufficient starting torque is available. Contact Frick if assistance is required.**

2. If specified, the starter package can be supplied as a combination starter with circuit breaker disconnect. However, the motor overcurrent protection/disconnection device can be applied by others, usually as a part of an electrical power distribution board.

3. A 3.0 KVA control power transformer (CPT) to supply 120 volt control power to the control system and separator oil heaters is included. If environmental conditions require more than 2000 watts of heat, an appropriately oversized control transformer will be required.

4. One normally open compressor motor starter auxiliary contact should be supplied and wired as shown on the starter package wiring diagram. In addition, the compressor starter coil and the CPT secondaries should be wired as shown on the starter package wiring diagram, Figure 9.

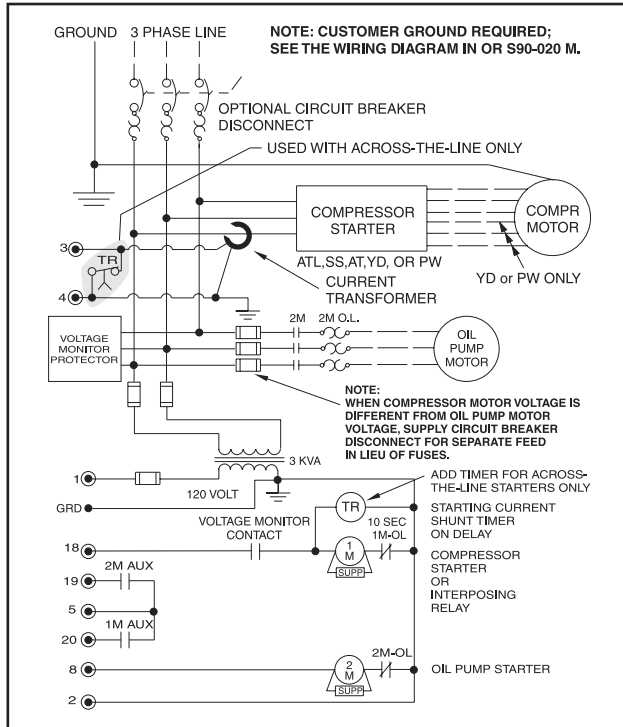

**Figure 9 - Starter Wiring Diagram**

5. The compressor motor Current Transformer (CT) can be installed on any one phase of the compressor leads. **NOTE: the CT must see all the current on any one phase, therefore in wye-delta applications BOTH leads of any one phase must pass through the CT.**

**CURRENT TRANSFORMER SIZE**

Calculate (CT) size using the following formula where SF is Service Factor and FLA is Full Load Amps of the Motor.

$$FLA \times SF \times 1.1$$

(round up to the next hundred)

Example: FLA = 379; Service Factor = 1.15  
 $379 \times 1.15 \times 1.1 = 479$

Use a 500:5 CT

**DO NOT** use undersized current transformers since the panel will not be capable of reading potential current. If the CT is higher than calculated, enter it's value for [CT Factor] on the panel. The unit can operate with a CT one size larger than calculated, however, replace with the proper size ASAP. **DO NOT** operate unit with a CT more than one size larger than recommended.

**MINIMUM BURDEN RATINGS**

The following table gives the minimum CT burden ratings. This is a function of the distance between the motor starting package and the compressor unit.

BURDEN RATING		MAXIMUM DISTANCE FROM FRICK PANEL		
ANSI	VA	USING # 14 AWG	USING # 12 AWG	USING # 10 AWG
B-0.1	2.5	15 ft	25 ft	40 ft
B-0.2	5	35 ft	55 ft	88 ft
B-0.5	12.5	93 ft	148 ft	236 ft

**NOTE: Do not install a compressor HAND/OFF/AUTO switch in the starter package as this would bypass the compressor safety devices.**

**CONTROL POWER REGULATOR**

Compressor units that will be used in areas that suffer brown-outs and other significant power fluctuations can be supplied with a control power regulator. See Figure 10, Recommended Regulator Installation.

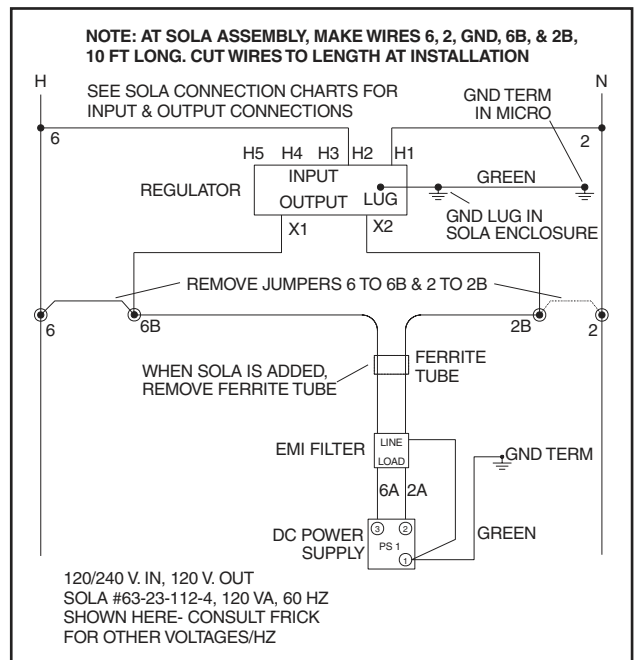

**Figure 10 - Recommended Regulator Installation**

**BATTERY BACKUP**

The battery backup is used only for date and time retention during power interruption. All setpoints and other critical information are saved on flash memory.

**NOTE: It is not necessary to disconnect the battery backup during extended downtime.**

## Operation

### OPERATION and START-UP INSTRUCTIONS

The Frick RFX Rotary Screw Compressor Unit is an integrated system consisting of six major subsystems:

Control Panel – See publications S90-020 O, M, & CS (also S90-021 & -022 O) for *QUANTUM™ LX*; Compressor; Compressor Lubrication System; Compressor Oil Separation System; Compressor Hydraulic System; Compressor Oil Cooling System.

The information in this section of the manual provides the logical step-by-step instructions to properly start up and operate the RFX Rotary Screw Compressor Unit.

**NOTE: For alarm descriptions and shutdown or cutout parameters, see publication S90-020, -021, -022 O.**



**THE FOLLOWING SUBSECTIONS MUST BE READ AND UNDERSTOOD BEFORE ATTEMPTING TO START OR OPERATE THE UNIT.**

### RXF COMPRESSOR

The Frick RFX rotary screw compressor utilizes mating asymmetrical profile helical rotors to provide a continuous flow of refrigerant vapor and is designed for high pressure applications. The compressor incorporates the following features:

1. High capacity roller bearings to carry radial loads at both the inlet and outlet ends of the compressor.
2. Heavy-duty angular contact ball bearings to carry axial loads are mounted at the discharge end of compressor.
3. Moveable slide valve to provide infinite step capacity control from 100% to 25% of full load capacity.
4. VOLUMIZER® II adjusts to the most efficient of three volume ratios (2.2, 3.5 or 5.0) depending upon system requirements.
5. Hydraulic cylinders to operate the volumizer slide stop and slide valve.
6. Compressor housing suitable for 350 PSI pressure.
7. Most bearing and control oil is vented to closed threads in the compressor instead of suction port to avoid performance penalties from superheating suction gas.
8. The shaft seal is designed to maintain operating pressure on the seal well below discharge pressure for increased seal life.
9. Oil is injected into the rotors to maintain good volumetric and adiabatic efficiency, even at very high compression ratios.



**Compressor rotation is clockwise when facing the end of the compressor drive shaft. The compressor should never be operated in reverse rotation as bearing damage will result.**

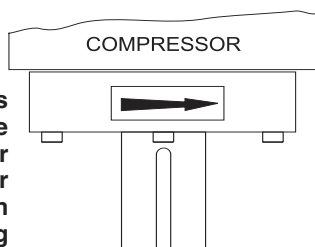

### COMPRESSOR LUBRICATION SYSTEM

The RFX compressor is designed specifically for operation without an oil pump for high stage service. Boosters and some low-differential pressure applications will require the demand pump option.

The lubrication system on an RFX screw compressor unit performs several functions:

1. Lubricates the rotor contact area, allowing the male rotor to drive the female rotor on a cushioning film of oil.
2. Provides lubrication of the bearings and shaft seal.
3. Serves to remove the heat of compression from the gas, keeping discharge temperatures low and minimizing refrigerant or oil breakdown.
4. Fills gas leakage paths between or around the rotors with oil, thus greatly reducing gas leakage and maintaining good compressor performance even at high compression ratios.
5. Provides oil pressure for development of balance load on the balance pistons to reduce bearing loading and increase bearing life.

### NO PUMP OIL SYSTEM

The RFX screw compressor unit is designed to be self-lubricating. Oil being supplied to the compressor from the oil separator is at system head pressure. Within the compressor, oil porting to all parts of the compressor is vented back to a point in the compressor's body that is at a pressure lower than compressor discharge pressure. The compressor's normal operation makes the compressor unit operate essentially as its own oil pump. All oil entering the compressor is moved by the compressor rotors out the compressor outlet and back to the oil separator. For normal high-stage operation an oil pump is not required.

### COLD-START SYSTEM

The RFX package is equipped with a special "cold-start" discharge check valve on the gas outlet connection of the oil separator. This valve causes the oil separator to develop oil pressure rapidly on initial start in order to lubricate the compressor without requiring an oil pump, even in cold ambient temperatures with all pressures equalized. See Figure 11.

For high-stage packages, the cold-start valve is equipped with a large spring that creates 30 psi of pressure in the oil separator (above suction pressure), for lubrication of the compressor.

**DO NOT ATTEMPT TO SERVICE THE COLD-START VALVE. PLEASE CONTACT THE FRICK SERVICE DEPARTMENT.**

Once the compressor is running it will begin to force gas to the condenser at connection P2. See Figure 11. As the condenser heats up it will begin to rise in pressure as the compressor suction pulls down in pressure. As soon as differential pressure is developed between the condenser and suction, these pressures act across a piston inside the cold-start valve to partially overcome the spring force. When the differential pressure reaches and exceeds 30 psi, the piston fully overcomes the spring force and powers the valve fully open for very low operating pressure drop.

For booster applications, the valve is equipped with a lighter spring which produces 1/2 bar (7 psig) oil pressure above suction pressure before it fully powers open.

The RXF package is also equipped with a suction check valve bypass. The oil separator will slowly bleed down to system suction pressure when the unit is stopped. This allows the compressor drive motor to have an easier start, and the discharge check valve will seat more tightly. See the "SUCTION CHECK VALVE BYPASS" section for operation.

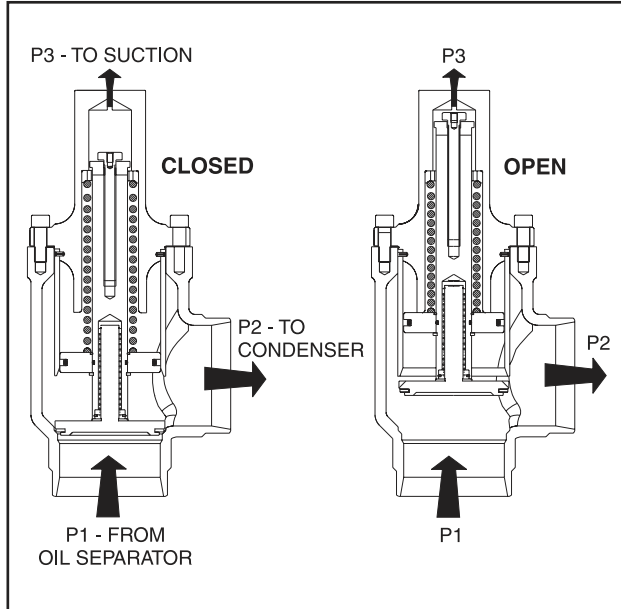

**Figure 11**

**DEMAND PUMP OIL SYSTEM**

This system is designed to provide adequate compressor lubrication for some high stage applications that operate with low differential pressure across the compressor suction and discharge and all booster applications.

During the period from start-up to normal operation the oil pressure alarm and oil pressure cutout setpoints will vary according to formulas built into the microprocessor control program.

**COMPRESSOR OIL SEPARATION SYSTEM**

The RXF is an oil-flooded screw compressor. Most of the oil discharged by the compressor separates from the gas flow in the oil charge reservoir. Some oil, however, is discharged as a mist which does not separate readily from the gas flow and is carried past the oil charge reservoir. The coalescer filter element then coalesces the oil mist into droplets, the droplets of oil fall to the bottom of the coalescer section of the oil separator. The return of this oil to the compressor is controlled by a hand expansion valve (HV1). See Figure 12.

**NOTE: Open HV1 only enough to keep the coalescer end of the separator free of oil.**

The sight glass located near the bottom of the coalescer section of the oil separator should remain empty during normal operation. If an oil level develops and remains in the sight glass, a problem in the oil return separation system or compressor operation has developed. Refer to Maintenance for information on how to correct the problem.

**NOTE: Normal operating level is between the top sight glass and bottom sight glass located midway along the oil separator shell.**

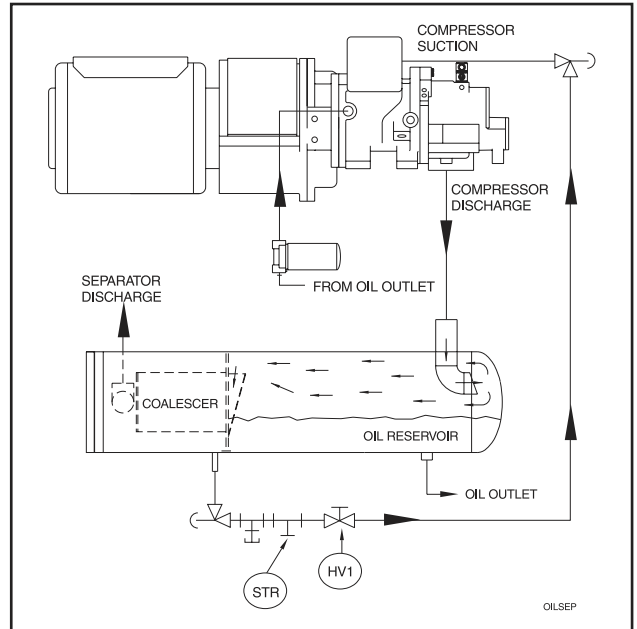

**Figure 12**

**COMPRESSOR HYDRAULIC SYSTEM**

The hydraulic system of the RXF compressor utilizes oil pressure from internally drilled passages in the compressor casing to selectively load and unload the compressor by applying this pressure to the actuating hydraulic piston of the movable slide valve (MSV). It also uses oil pressure to actuate a hydraulic piston that moves the movable slide stop, Volumizer® II. This allows adjustment of the compressor volume ratio, (Vi) while the compressor is running.

**CAPACITY CONTROL**

**COMPRESSOR LOADING:** The compressor loads when MSV solenoid coil YY2 is energized and oil flows from the solenoid valve through the needle valve (HV2) to compressor port 2, where it enters the load side of the slide valve piston. This equalizes the force on the slide valve piston and discharge pressure on the slide valve area loads the compressor. See Figure 13.

**COMPRESSOR UNLOADING:** The compressor unloads when MSV solenoid YY1 is energized and oil is allowed to flow from compressor port 2 thru the needle valve to the MSV solenoid. This allows discharge pressure on the slide valve piston to unload the slide valve as the piston moves outward.

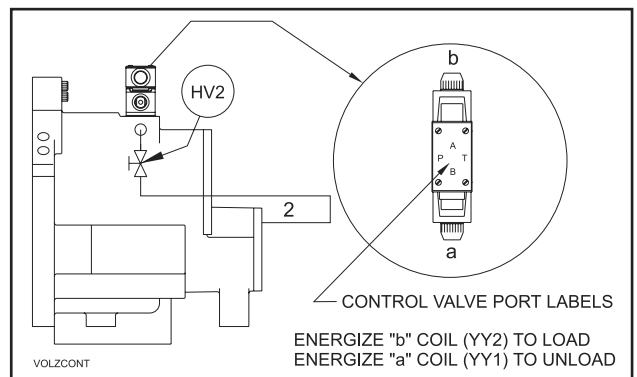

**Figure 13**



**ADJUSTMENT (Capacity Control):** A needle valve (HV2) is provided to adjust slide valve travel time, preventing excessive slide valve “hunting”. HV2 should be adjusted to restrict oil flow to the compressor port so that slide valve travel time from full load to full unload, or vice versa, is a minimum of 30 seconds.

**NOTE: A change in operating conditions, such as winter-to-summer operation, may require readjustment of slide valve travel time.**

### VOLUMIZER® II Vi CONTROL

The RXF compressor is equipped with a special internal control that automatically adjusts the compressor volume ratio to the most efficient of three available steps, (2.2, 3.5, or 5.0 volume ratio). This gives the compressor the ability to operate at varying operating conditions while minimizing power consumption by avoiding over or undercompression.

Solenoid valves 3 and 4 control the Volumizer® II volume ratio control. Oil is internally ported to apply hydraulic pressure to two stepping pistons in order to move the moveable slide stop to the optimum position. The following chart shows the logic of solenoid operation to adjust the volume ratio.

Vi	YY3	YY4
2.2	Energized	Energized
3.5	Deenergized	Energized
5.0	Deenergized	Deenergized

Proper operation of the Volumizer® II control can be checked as follows.

1. Confirm that the slide valve travel number in Factory Setup is set at 190 degrees. If necessary, adjust the setting to 190 degrees before proceeding further.
2. Set the compressor Vi to 2.2, then record the voltage that is shown on the Slide Valve calibration screen for the current Slide Valve and 0% Slide Valve positions. The difference between these voltages must be in the 1.35 - 1.65 Vdc range.
3. Set the compressor Vi to 3.5, then record the voltage that is shown on the Slide Valve calibration screen for the current Slide Valve and 0% Slide Valve positions. The difference between these voltages must be in the 0.95 - 1.15 Vdc range.
4. Set the compressor Vi to 5.0, then record the voltage that is shown on the Slide Valve calibration screen for the current Slide Valve and 0% Slide Valve positions. The difference between these voltages must be in the 0.73 - 0.93 Vdc range.
5. If the above voltage measurements are all in range, the Volumizer® II is working properly. If any of the voltages are out of range, go to the troubleshooting section

### COMPRESSOR OIL COOLING SYSTEMS

The RXF unit can be equipped with one of several systems for controlling the compressor oil temperature. They are single or dual-port liquid injection, thermosyphon, or water-cooled oil coolers. Each system is automatically controlled, independent of compressor loading or unloading.

Oil cooling systems maintain oil temperature within the following ranges for R-717 and R-22:

- Liquid Injection Oil Cooling - 130 - 150°F
- External\* Oil Cooling - 120 - 140°F

\* Thermosyphon Oil Cooling (TSOC) or Water-Cooled Oil Cooling (WCOC).

### SINGLE-PORT LIQUID INJECTION

The single-port liquid injection system is designed to permit liquid refrigerant injection into one port on the compressor at any given moment and operates as outlined.

The liquid injection solenoid valve is energized by the micro-processor when the temperature sensor, installed in the compressor discharge, exceeds the setpoint. High-pressure liquid refrigerant is then supplied to the temperature control valve (TCV). **Refer to P & I DIAGRAMS section for piping and instrumentation drawings.**

### DUAL-PORT LIQUID INJECTION

The dual-port liquid injection system is designed to obtain the most efficient compressor performance at high and low compression ratios by permitting injection of liquid refrigerant into one of two ports optimally located on the compressor. This minimizes the performance penalty incurred with liquid injection oil cooling.

The dual-port system contains all the components of the single-port system with the addition of a double-acting solenoid valve and operates as outlined.

The liquid injection solenoid valve is energized by the micro-processor when the temperature sensor, installed in the oil manifold, exceeds the setpoint. Liquid refrigerant is then passed through the temperature control valve (TCV) to the double-acting solenoid valve. Depending on the compressor's operating volume ratio (Vi), the microprocessor will select the flow of the liquid refrigerant to the optimum compressor port.

## QUANTUM™LX EZ-COOL™ LIQUID INJECTION ADJUSTMENT PROCEDURE

Use the following directions to set up and tune the EZ-Cool™ LIOC with a Quantum™LX Control Panel. Also refer to publication S90-022 O, Quantum™LX Operation, for an overview of PID control.

First, complete calibration of the analog output used for EZ-Cool™ LIOC. Typically, this will be analog output #1 for PID #1.

- Power down the panel and remove the two control wires for the valve from terminals 1 & 2 of the P11A terminal strip of analog board #1.
- Place the leads of a calibrated, quality meter to terminal one (positive) and terminal two (negative). Set the meter to read mA DC and power up the panel.
- Set operating session to Session 2 and go to the screen shown in Figure 14 by pressing [Menu] >[Calibration] > [Analog Outputs] > [Output Calibration].

- Press [ 1 ] on the keypad to drive the output to the low end. Using numbers [ 4 ], [ 7 ], and [ 0 ] on the keypad to increase and decrease the output and change the “Delta For Changing Output Percentage” setpoint, set the output to 4mA.
- If the read value is less than the objective of 4 or 20mA use [ 7 ] on the keypad to increase the output by the Delta. If the read value is more than the objective, use [ 4 ] to decrease the value by the Delta.
- Use the [ 0 ] key to change the Delta from 10 to 1, .10 or .01% to tune the output to the objective of 4 or 20mA.
- Press [ 3 ] on the keypad to set the output to the high end and repeat the process in the preceding steps to set the output to 20mA.
- Power down the panel, remove the meter and reconnect the control wires for the EZ-Cool™ LIOC valve as they were removed to terminals 1 & 2 of the P11A terminal strip of analog board #1.

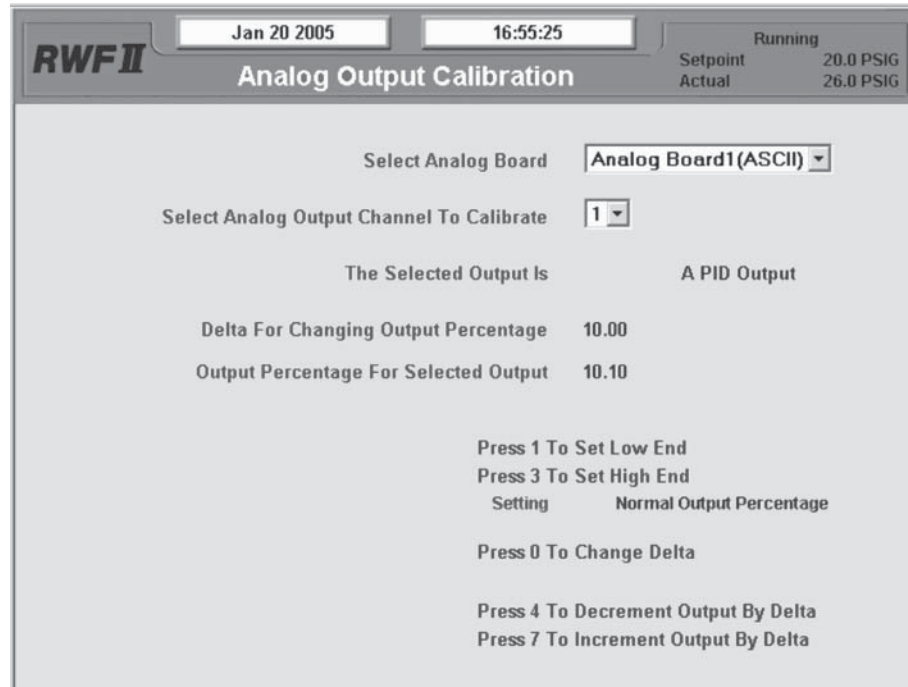

Figure 14

### Description of Proportional Band and Gain setpoints:

- **Proportional Band** – This setpoint determines the size of a region either above or below the Control Setpoint. Within this region the Proportional component of the PID Output value is the number between 0% and 100% that directly corresponds to the difference between the Control Input (Actual) and the Control Setpoint (Setpoint). Outside of this region the Proportional component is either 100% or 0%. If the PID Action is Forward, the Proportional Band extends above the Control Setpoint. If the PID Action is Reverse, the Proportional Band extends below the Control Setpoint.
- **Proportional Gain** - This value is calculated from the Proportional Band setpoint and is the same value that was entered as a Proportional Gain setpoint in the Quantum. The control setpoint will not be achieved with proportional control only. Integral control is needed to further correct the control input to achieve the setpoint.

- **Integral Gain** - This setpoint controls the influence the Integral component exerts on the PID Output value. The Integral component works to push the Control Input toward the Control Setpoint by tracking the difference between the Control Input and the Control Setpoint over time.
- **Derivative Gain** - This setpoint controls the influence the Derivative component exerts on the PID Output value. The Derivative component reacts to rapid changes in the value of the Control Input by predicting the direction the Control Input is traveling and then turning it back toward the Control Setpoint.

### Example of Proportional Only Control:

Control Input:	Discharge Temperature
Control Setpoint:	150°F
Dead Band:	0°F
Proportional Band:	25
Action:	Forward

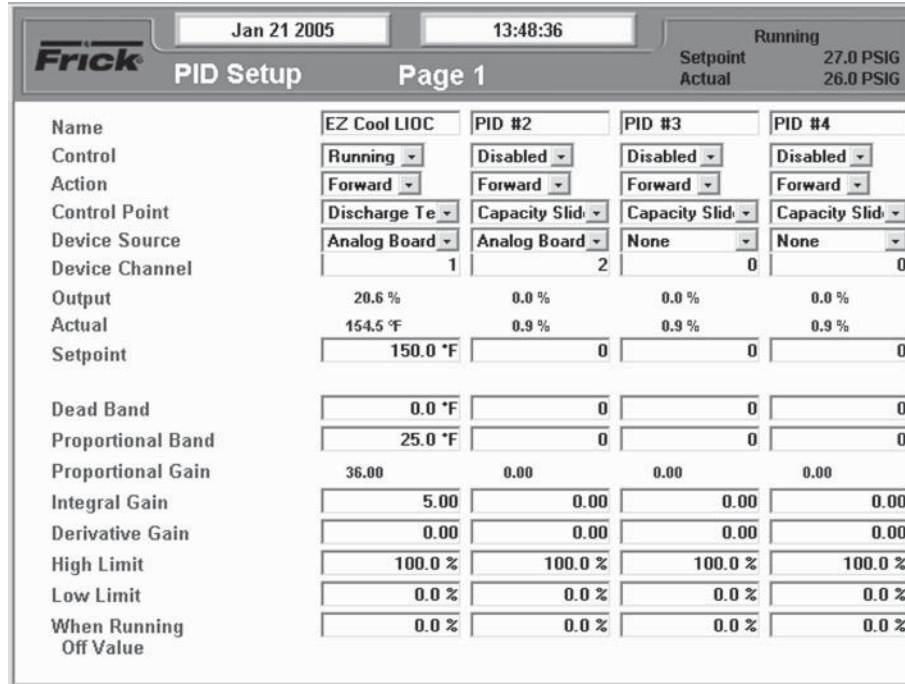

Figure 15

- Using the chart below, as long as the control input is 155°F the output will be at 20% with proportional control only. Integral control will increase the output in increments, over time, to correct the control input to the setpoint.

Control Input	Output %
150°F	0%
155°F	20%
160°F	40%
165°F	60%
170°F	80%
175°F	100%

Based on these descriptions set PID #1 for EZ-Cool™ LIOC per Figure 15 as a starting point. Tuning of the output will be required. There should be no need to use a derivative gain.

**NOTES:**

- Set the “Liquid Slugging” Alarm and Shutdown setpoints to 90 to prevent nuisance shutdowns during the tuning process. Be sure to return these setpoints to their original values when finished.
- While the discharge temperature will be the Control Point, it reacts quickly to adjustments. Be sure to allow an adjustment to the proportional band or integral gain setpoints the opportunity to counter and correct the control input (discharge temperature) before making additional adjustments.
- Tune the output by making small adjustments of 1-5 to the Proportional Band and .1-.5 of the Integral Gain setpoints. Adjust only one at a time, allowing each adjustment time to settle out.

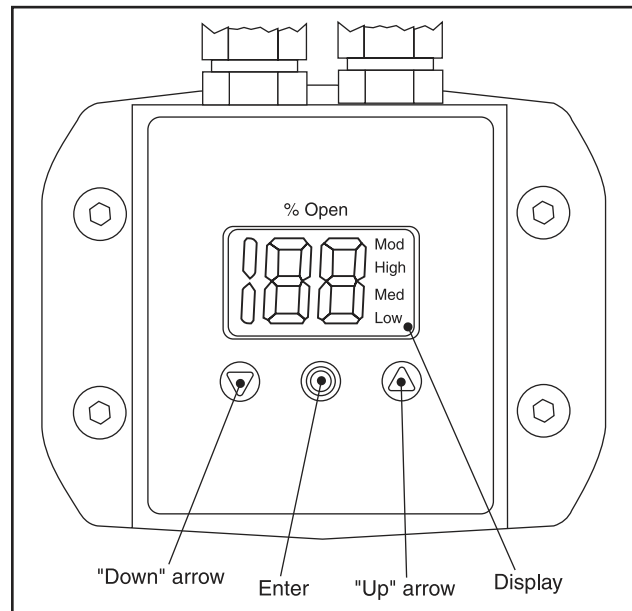

Figure 16

**OPERATION OF DANFOSS LIQUID INJECTION VALVE**

ICAD (Industrial Control Actuator with Display) is equipped with an MMI (Man Machine Interface) from which it is possible to monitor and change the setting of parameters to adapt the ICAD and the corresponding ICM (Motorized Industrial Control Valve) to the actual refrigeration application.

The setting of parameters is managed by means of the integrated ICAD MMI (Figures 16 and 17) and consists of:

- “Down” arrow push button (Figure 16)
  - Decreases parameter number by 1 at each activation.
- “Up” arrow push button (Figure 16)
  - Increases parameter number by 1 at each activation.

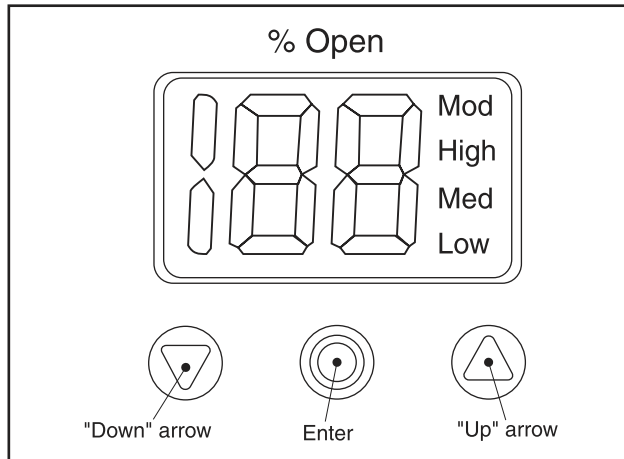

**Figure 17**

- Enter push button (Figure 16)
  - Gives access to the Parameter list by keeping the push button activated for 2 seconds. A Parameter list example is shown below (parameter **i08**, Figure 18).

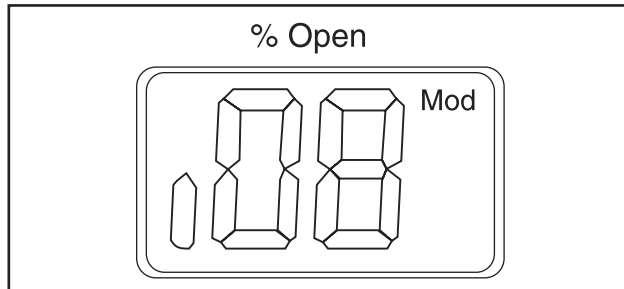

**Figure 18**

- Gives access to change a value once the Parameter list has been accessed.
- Acknowledge and save change of value of a parameter.
- To exit from the Parameter list and return to the display of Opening Degree (OD), keep the push button activated for 2 seconds.
- Display (Figure 16)
  - Normally the Opening Degree (OD) 0 - 100% of the ICM valve is displayed. No activation of push buttons for 20 seconds means that the display will always show OD (Figure 19).

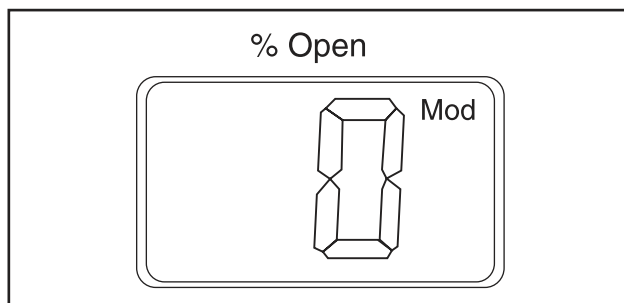

**Figure 19**

- Displays the parameter.
- Displays the actual value of a parameter.
- Displays the function status by means of text (Figure 16).
  - **Mod** represents that ICAD is positioning the ICM valve according to an analog input signal (Current or Voltage).

- **Low** represents that ICAD is operating the ICM valve like an ON/OFF solenoid valve with low speed according to a digital input signal.
- **Med** represents that ICAD is operating the ICM valve like an ON/OFF solenoid valve with medium speed according to a digital Input signal.
- **High** represents that ICAD is operating the ICM valve like an ON/OFF solenoid valve with high speed according to a digital input signal (Figure 20).

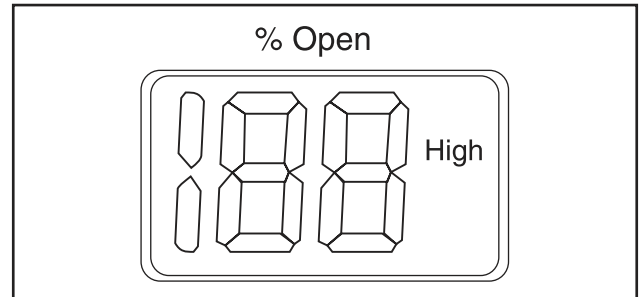

**Figure 20**

**Alarms - ICAD can handle and display different alarms.**

Description	ICM Alarm Text	Comments
No valve type selected	<b>A1</b>	At start-up <b>A1</b> and <b>CA</b> will be displayed
Controller fault	<b>A2</b>	Internal fault inside electronics
All input error	<b>A3</b>	Not active if <b>j01</b> = 2 or <b>j02</b> = 2 When <b>j03</b> = 1 and AI A > 22 mA When <b>j03</b> = 2 and AI A > 22 mA or AI A < 2mA When <b>j03</b> = 3 and AI A > 12V When <b>j03</b> = 4 and AI A > 12V or AI A < 1 V
LOW voltage of fail-safe supply	<b>A4</b>	If 5 V d.c. < Fail-safe supply < 18 V d.c.
Check Supply to ICAD	<b>A5</b>	If supply voltage < 18 V d.c.

If an alarm has been detected the ICAD display (Figure 16) will alternate between showing Actual alarm and present Opening Degree.

If more than one alarm is active at the same time, the alarm with the highest priority will take preference. **A1** has the highest priority, **A5** the lowest.

Any active alarm will activate the Common Digital Alarm output (Normally Open).

All alarms will automatically reset themselves when they physically disappear.

Old alarms (alarms that have been active, but have physically disappeared again) can be found in parameter **j11**.

**Reset to factory setting:**

1. Remove the power supply.
2. Activate down arrow and up arrow push buttons at the same time.
3. Connect the power supply.
4. Release down arrow and up arrow push buttons.
5. When the display on ICAD (Figure 16) is alternating between showing: **CA** and **A1** the factory resetting is complete.

Parameter list

Description	Display Name	Min.	Max.	Factory Setting	Unit	Comments
ICM OD (Opening Degree)	-	0	100	-	%	ICM valve Opening Degree is displayed during normal operation. Running display value (see j01, j05).
Main Switch	j01	1	2	1	-	Internal main switch 1: Normal operation 2: Manual operation. Valve Opening Degree will be flashing. With the down arrow and the up arrow push buttons the OD can be entered manually.
Mode	j02	1	2	1	-	Operation mode 1: Modulating - ICM positioning according to Analogue input (see j03) 2: ON/OFF - operating the ICM valve like an ON/OFF solenoid valve controlled via Digital Input. See also j09.
Analog Input signal	j03	1	4	2	-	Type of Analog input signal from external controller 1: 0-20mA 2: 4-20mA 3: 0-10V 4: 2-10V
Speed at ON/OFF and Modulating Mode	j04	1	100	100	%	Speed can be decreased. Max. speed is 100 % Not active when j01 = 2 If j02 = 2, the display will indicate speed in display. <b>Low, Med, and High</b> also means ON/OFF operation. If j04 < = 33, <b>Low</b> is displayed 33 < j04 < = 66, <b>Med</b> is displayed If j04 > = 67, <b>High</b> is displayed
Automatic calibration	j05	0	1	0	-	Not active before j26 has been operated. Always auto reset to 0. <b>CA</b> will flash in the display during calibration.
Analog Output signal	j06	0	2	2	-	Type of A0 signal for ICM valve position 0: No signal 1: 0 - 20mA 2: 4 - 20mA
Fail-safe	j07	1	4	1	-	Define condition at power cut when fail-safe is installed. 1: Close valve 2: Open valve 3: Maintain valve position 4: Go to OD given by j12
Digital Input function	j09	1	2	1	-	Define function when DI is ON (short circuited DI terminals) when j02 = 2 1: Open ICM valve (DI = OFF => Close ICM valve) 2: Close ICM valve (DI = OFF => Open ICM valve)
Password	j10	0	199	0	-	Enter number to access password protected parameters: j26
Old Alarms	j11	A1	A99	-	-	Old alarms will be listed with the latest shown first. Alarm list can be reset by means of activating down arrow and up arrow at the same time for 2 seconds.
OD at powercut	j12	0	100	50	-	Only active if j07 = 4 If fail-safe supply is connected and powercut occurs, ICM will go to entered OD.
ICM configuration	j26	0	6	0	-	<b>NB:</b> Password protected. Password = 11 At first start-up, <b>A1</b> will flash in display. Enter valve type. 0: No valve selected. Alarm <b>A1</b> will become active. 1: ICM20 with ICAD 600 2: ICM25 with ICAD 600 3: ICM32 with ICAD 600 4: ICM40 with ICAD 900 5: ICM50 with ICAD 900 6: ICM65 with ICAD 900
OD%	j50	0	100	-	%	ICM valve Opening Degree
AI [mA]	j51	0	20	-	mA	Analog Input signal
AI [V]	j52	0	10	-	V	Analog Input signal
AO [mA]	j53	0	20	-	mA	Analog Output signal
DI	j54	0	1	-	-	Digital Input signal
DO Close	j55	0	1	-	-	Digital Output Closed status. ON when OD < 3%
DO Open	j56	0	1	-	-	Digital Output Open status. ON when OD > 97%
DO Alarm	j57	0	1	-	-	Digital Output alarm status. ON when an alarm is detected
MAS mP SW ver.	j58	0	100	-	-	Software version for MASTER Microprocessor
SLA mP SW ver.	j59	0	100	-	-	Software version for SLAVE Microprocessor

## INSTALLATION AND OPERATION OF HANSEN LIQUID INJECTION VALVE

### Installation

1. Protect the interior of the valve from dirt and moisture during storage and installation.
2. Install valve with arrow pointed in the direction of flow.
3. Filters or strainers should be installed up stream of the valve.
4. For proper flange gasket sealing, care must be taken when threading or welding to assure flanges are parallel to each other and perpendicular to the pipe. Also, gaskets should be lightly oiled and all bolts must be tightened evenly.
5. Proper wiring is essential. Each wire is numbered. Consult Hansen or Frick wiring diagrams for proper termination.

### Calibration (or Recalibration)

1. The valve is shipped from the factory calibrated, so no calibration is necessary unless:
  - a. The Power Head (motor) is removed from the valve.
  - b. The valve is taken apart.

2. Install Calibration Key over 'X' on the side of the motor and secure with a strap. Make sure the proper side of the magnet is facing out.

3. Increase the control input to 20mA or slightly greater. Maintain at least 20mA for at least 2 minutes. This will give the valve time to move to the wide open position and calibrate its position. **NOTE: some computer control systems have lag times before the control input is sent to the valve.**

4. Decrease the control input to 4mA or less. Maintain 4mA or less for at least two minutes. This will give the valve time to move to the completely closed position and calibrate its zero point. The motor will pulse for 30 seconds after it closes completely and then shut off.

5. Again increase the control input to at least 20mA. Maintain at least 20mA for at least two minutes. This will give the valve time to move to the wide open position and set its span.

6. Remove calibration Key and store. The valve is now calibrated. If the Key is left over the 'X', the valve will recalibrate each time the control input is at 4mA or 20mA for more than the two minutes.

### Troubleshooting Guide

VALVE DOES NOT OPERATE	Motor does not pulse when milliamp signal is changing.	24 VAC lacking	Check 24VAC across valve wires #1 & #2.
		Miswired	Double-check numbers printed on power head wires vs. wiring diagram.
		4-20mA wires reversed	Follow wiring diagram to be sure wire goes from positive on one terminal to negative terminal around the 4-20mA loop.
		No 4-20mA signal to valve	Check milliamp signal to power head on either wires 3 or 4. Install milliamp meter in series with 4-20mA signal to power head to confirm proper signal.
		Loose powerhead	Rusty inside - replace.
VALVE WILL NOT CLOSE	Valve position does not change with change to 4-20mA signal. Motor pulses.	Excess dirt in valve	Clean valve and recalibrate.
		Can dented causing interference with rotor	Replace Can and recalibrate valve. Use MOVIT tool to protect Can when servicing valve.
VALVE WILL NOT OPEN	Valve position does not change with change to 4-20mA signal. Motor pulses	Insufficient voltage	24 VAC wires undersize. Check wire size and replace if necessary.
		Shaft thread worn excessively	Remove power head. Use manual tool MOVIT to rotate rotor. Rotor should rotate smoothly. If not, disassemble valve, clean valve and threads, replace Vport if threads worn excessively.
		Excess dirt or free water in valve	Clean valve and recalibrate.
VALVE DOES NOT MAINTAIN TEMPERATURE	Temperature too high	Insufficient voltage	24VAC wires undersize. Check wire size and replace if necessary.
		Shaft thread worn excessively	Remove power head. Use manual tool MOVIT to rotate rotor. Rotor should rotate smoothly. If not, disassemble valve, clean valve and threads, replace Vport if threads worn excessively.
		Excess dirt or free water in valve	Clean valve and recalibrate.
VALVE DOES NOT HUNT	Does not maintain constant temperature	Valve undersize	Run valve wide open manually to confirm valve is undersize.
		Valve not calibrated	Calibrate valve.
VALVE HUNTS	Does not maintain constant temperature	PID constants not set properly	Speed up temperature response by moving temperature sensor location closer or into vessel. If sensor is in a well, speed up sensor response time by using thermal oil in well. Set I and D to zero, and set P to minimize swings under load. Add I if valve is too lazy. Be wary of using auto-tuning function of controller on chiller applications.
		Readout is zero	Install 24VDC power supply.
		Readout incorrect	Install independent 24VDC power supply to confirm proper reading.
VALVE POSITION FEEDBACK DOES NOT WORK (CUSTOMER SUPPLIED CONTROLLER)	Readout is above 100% and does not change	Power supply missing	Recalibrate valve. See instructions.
		Disturbance from other devices on 4-20mA supply	
		Power head was removed and reinstalled	

## INITIAL START-UP PROCEDURE

Having performed the checkpoints on the Prestart Checklist (see FORMS in Table of Contents), the compressor unit is ready for start-up. It is important that an adequate refrigerant load be available to load test the unit at normal operating conditions. The following points should be kept in mind during initial start-up.

1. On start-up the unit should be operated at as high a load possible for 3 hours. During the period, adjust liquid injection oil cooling, if applicable. If unit has water-cooled oil cooling, adjust water control valve to cooler (if applicable).
2. The compressor slide valve should be calibrated.
3. Pull and clean suction strainer after 24 hours operation. If it is excessively dirty, repeat every 24 hours until system is clean. Otherwise, follow the Maintenance Schedule. See the Recommended Maintenance Program section.

## NORMAL START-UP PROCEDURE

1. Confirm system conditions permit starting the compressor.
2. Press the **[RUN]** key.
3. Allow the compressor to start up and stabilize. At start-up, the slide stop (volumizer) and the slide valve (capacity control) are in the **AUTO** mode.

## RESTARTING COMPRESSOR UNIT AFTER CONTROL POWER INTERRUPTION (PLANT POWER FAILURE)

1. Check **ADJUSTABLE** setpoints.
2. Follow normal start-up procedure.

## MAINTENANCE

This section provides instructions for normal maintenance, a recommended maintenance program, troubleshooting and correction guides, typical wiring diagrams and typical P and I diagrams.

### WARNING

**This section must be read and understood before attempting to perform any maintenance or service to the unit.**

### NORMAL MAINTENANCE OPERATIONS

When performing maintenance you must take several precautions to ensure your safety:

### CAUTION

1. IF UNIT IS RUNNING, PUSH [STOP] KEY TO SHUT DOWN THE UNIT.
2. DISCONNECT POWER FROM UNIT BEFORE PERFORMING ANY MAINTENANCE.
3. WEAR PROPER SAFETY EQUIPMENT WHEN COMPRESSOR UNIT IS OPENED TO ATMOSPHERE.
4. ENSURE ADEQUATE VENTILATION.
5. TAKE NECESSARY SAFETY PRECAUTIONS REQUIRED FOR THE REFRIGERANT BEING USED.

### WARNING

**CLOSE ALL COMPRESSOR PACKAGE ISOLATION VALVES PRIOR TO SERVICING THE UNIT. FAILURE TO DO SO MAY RESULT IN SERIOUS INJURY.**

### GENERAL MAINTENANCE

Proper maintenance is important in order to assure long and trouble-free service from your screw compressor unit. Some areas critical to good compressor operation are:

1. Keep refrigerant and oil clean and dry, avoid moisture contamination. After servicing any portion of the refrigeration system, evacuate to remove moisture before returning to service. Water vapor condensing in the compressor while running, or more likely while shut down, can cause rusting of critical components and reduce life.
2. Keep suction strainer clean. Check periodically, particularly on new systems where welding slag or pipe scale could find its way to the compressor suction. Excessive dirt in the suction strainer could cause it to collapse, dumping particles into the compressor.
3. Keep oil filters clean. If filters show increasing pressure drop, indicating dirt or water, stop the compressor and change filters. Running a compressor for long periods with high filter pressure drop can starve the compressor for oil and lead to premature bearing failure.
4. Avoid slugging compressor with liquid refrigerant. While screw compressors are probably the most tolerant to ingestion of some refrigerant liquid of any compressor type available today, they are not liquid pumps. Make certain to maintain adequate superheat and properly size suction accumulators to avoid dumping liquid refrigerant into compressor suction.

Keep liquid injection valves properly adjusted and in good condition to avoid flooding compressor with liquid. Liquid can

cause a reduction in compressor life and in extreme cases can cause complete failure.

5. Protect the compressor during long periods of shut down. If the compressor will be setting for long periods without running it is advisable to evacuate to low pressure and charge with dry nitrogen or oil, particularly on systems known to contain water vapor.

6. Preventive maintenance inspection is recommended any time a compressor exhibits a noticeable change in vibration level, noise or performance.

### COMPRESSOR SHUTDOWN and START-UP

**For seasonal or prolonged (six months) shutdown, use the following procedure:**

1. Push [STOP] key to shut down unit.
2. Open disconnect switch for compressor motor starter.
3. Turn off power.
4. Isolate the package by closing all package valves to the system. Tag all closed valves.

### CAUTION

**Open any solenoid valves or other valves that may trap liquid between the isolation valves and other package valves to prevent injury or damage to components.**

5. With liquid injection, close the manual hand valve upstream of the solenoid and manually open the solenoid by turning "in" the manual opening stem (clockwise viewed from below valve).

6. Shut off the cooling water supply valve to the oil cooler. Drain water, if applicable. Attach **CLOSED** tags.

7. Protect oil cooler from ambient temperatures below freezing.

**NOTE: The unit should be inspected monthly during shutdown. Check for leaks or abnormal pressure. Use the maintenance log to record readings to verify the pressure stability of the unit. To prevent the seals and bearing from drying out, run oil pump (if available) and manually rotate the compressor shaft. Consult motor manufacturer for motor recommendations.**

**TO START UP AFTER SEASONAL OR PROLONGED SHUTDOWN, USE THE FOLLOWING PROCEDURE :**

1. Perform routine maintenance. Change oil and replace filters. Check strainers.
2. Any water necessary for the operation of the system that may have been drained or shut off should be restored or turned on.
3. Reset solenoid valves to automatic position, then open all valves previously closed. Remove tags.
4. Compressor unit is ready for prestart checks. Refer to **PRESTART CHECKLIST**.

### COMPRESSOR/MOTOR SERVICING

Before removing the motor from an RXF unit, it is critical that proper support be provided for the compressor to prevent damage to the oil separator. Insert blocks or a jack

between the separator shell and compressor casting. Make sure the weight is held safely by the separator shell. Loosen the compressor discharge flange bolts to relax any flange and pipe stress, then carefully remove the motor. Similarly, before removing the compressor for servicing, the back end of the motor must be supported to prevent damage. Again, insert either blocks or a jack between the rear of the motor and the separator shell.

## GENERAL INSTRUCTIONS FOR REPLACING COMPRESSOR UNIT COMPONENTS

When replacing or repairing components which are exposed to refrigerant, proceed as follows:

1. Push [STOP] key to shut down the unit.
2. Open disconnect switches for compressor motor starter and oil pump motor starter (if applicable).
3. Isolate the package by closing all package valves to the system. Tag all closed valves.



**Open any solenoid valves or other valves that may trap liquid between the isolation valves and**

**other package valves to prevent injury or damage to components.**

4. **SLOWLY** vent separator to low-side system pressure using the suction check valve bypass. **NOTE: Recover or transfer all refrigerant vapor, in accordance with local ordinances, before opening to atmosphere.** The separator **MUST** be equalized to atmospheric pressure.



**Oil entrained refrigerant may vaporize, causing a separator pressure increase. Repeat transfer and recovery procedure, if necessary.**

5. Make replacement or repair.
6. Isolate the low pressure transducer, PE-4, to prevent damage during pressurization and leak test.
7. Pressurize unit and leak test.
8. Evacuate unit to 29.88" Hg (1000 microns).
9. Open all valves previously closed and reset solenoid valves to automatic position. Remove tags.
10. Close disconnect switches for compressor motor starter and oil pump motor starter, if applicable.
11. Unit is ready to put into operation.

## OIL FILTER, SPIN-ON (RXF 12 – 50)



**Use of oil filters other than Frick may cause warranty claim to be denied.**

To change the filter proceed as follows:

1. Push [STOP] key to shut down the unit. Open disconnect switches for the compressor.
2. Isolate the package by closing all package valves to the system. Tag all closed valves.



**Open any solenoid valves or other valves that may trap liquid between the isolation valves and other**

**package valves to prevent injury or damage to components.**

**SLOWLY** vent separator to low-side system pressure using the suction check valve bypass. **NOTE: Recover or transfer all refrigerant vapor, in accordance with local ordinances, before opening to atmosphere.** The separator **MUST** be equalized to atmospheric pressure.



**Oil entrained refrigerant may vaporize, causing a separator pressure increase. Repeat transfer and recovery procedure, if necessary.**

3. Remove spin-on oil filter element and discard.
4. Replace with new oil filter element. Make finger tight plus an additional half turn.
5. Isolate the low pressure transducer, PE-4, to prevent damage during pressurization and leak test.
6. Pressurize and leak test. Evacuate unit to 29.88" Hg (1000 microns).
7. Open the suction and discharge service valves, and the low pressure transducer. Close disconnect switches for the compressor. Start the unit.

## OIL FILTER, SINGLE ELEMENT (58 – 101)



**Use of filter elements other than Frick may cause warranty claim to be denied.**

To change the filter cartridge proceed as follows:

1. If a single oil filter is installed, push [STOP] key to shut down the unit. Open disconnect switches for the compressor and (if applicable) oil pump motor starters.
2. Close discharge service valve. **SLOWLY** vent the separator to low-side system pressure using the suction check valve bypass. Close suction valve and suction check valve bypass. **NOTE: Recover or transfer all refrigerant vapor, in accordance with local ordinances, before opening to atmosphere. The oil filter cartridge MUST be equalized to atmospheric pressure before opening.**



**Oil-entrained refrigerant may vaporize, causing a pressure increase. Repeat venting and recovery procedure, if necessary.**

3. Close oil filter isolation valves. Open drain valve on oil filter head and drain the oil. Remove the canister cover. Discard the cartridge and gasket.
4. Flush the filter body with clean Frick refrigeration oil; wipe dry with a clean, lint-free cloth; and close drain valve.
5. Place a new cartridge in the filter canister. Replace the gasket and spring and reinstall the canister cover. Torque cover bolts in sequence to:
  - a. Finger tight
  - b. 17 ft-lb
  - c. 35 ft-lb
6. Isolate the low pressure transducer, PE-4, to prevent damage during pressurization and leak test.
7. Pressurize and leak test. Evacuate the unit to 29.88" hg (1000 microns).
8. Add 2 gallons of oil by attaching a suitable pressure-type hose to the oil-charging valve located on top of the separator. Use a pressure-type oil pump and recommended Frick oil.

9. Open the suction and discharge service valves, oil filter isolation valves, and the low pressure transducer. Readjust suction check valve bypass. Close disconnect switches for the compressor and (if applicable) the oil pump motor starters. Start the unit.

### COALESCER OIL RETURN STRAINER

1. Push **[STOP]** key to shut down the unit. Open disconnect switches for the compressor.

2. Isolate the package by closing all package valves to the system. Tag all closed valves.



**Open any solenoid valves or other valves that may trap liquid between the isolation valves and other pack-**

**age valves to prevent injury or damage to components. SLOWLY vent separator to low-side system pressure using the suction check valve bypass. NOTE: Recover or transfer all refrigerant vapor, in accordance with local ordinances, before opening to atmosphere. The separator MUST be equalized to atmospheric pressure.**



**Oil entrained refrigerant may vaporize, causing a separator pressure increase. Repeat transfer and recovery procedure, if necessary.**

3. Close strainer isolation valves. Remove the large plug from the bottom of the strainer and remove the element from the strainer.

4. Wash the element in solvent and blow clean with air.

5. Replace the cleaned element and removed plug. Open strainer isolation valves.

6. Isolate the low pressure transducer, PE-4, to prevent damage during pressurization and leak test.

7. Pressurize and leak test. Evacuate unit to 29.88" Hg (1000 microns).

8. Open the suction and discharge service valves, and the low pressure transducer. Close disconnect switches for the compressor. Start the unit.

### LIQUID INJECTION STRAINER

To clean the liquid injection strainer the unit must be shut down. The procedure is as follows:

1. Push **[STOP]** key to shut down the unit, then open disconnect switches for the compressor.

2. Close the liquid supply service valve located before the liquid solenoid.

3. **Immediately screw in the manual solenoid valve stem to relieve liquid refrigerant pressure trapped between the solenoid and the service valve.**

4. Close the service valve located between the compressor and the liquid injection thermal expansion valve.

5. Carefully loosen capscrews securing the strainer cover to the strainer. Allow pressure to relieve slowly.

6. When all entrapped refrigerant has been relieved, carefully remove loosened capscrews (as liquid refrigerant is sometimes caught in the strainer), strainer cover, and strainer basket.

7. Wash the strainer basket and cover in solvent and blow clean with air.

8. Reassemble the strainer.

9. Open the service valve between the compressor and the liquid injection thermal expansion valve, purge entrained air, and check for leakage.

10. Screw out the manual solenoid valve stem.

11. Carefully open the liquid supply service valve.

12. Leak test.

13. Close disconnect switches for compressor starter.

14. Start the unit.

### OIL PUMP STRAINER (Optional)

To clean the full-lube oil pump strainer, the unit must be shut down. The procedure is as follows:

1. Push **[STOP]** key to shut down the unit, then open the disconnect switches for the compressor and (if applicable) the oil pump motor starters.

2. Close strainer service valves.

3. Open the drain valve located in the strainer cover and drain the oil into a container.

4. Remove the capscrews securing the strainer cover, strainer cover gasket, and element. Retain the gasket.

5. Wash the element in solvent and blow it clean with air.

6. Wipe the strainer body cavity clean with a lint-free clean cloth.

7. Replace the cleaned element and gasket, then reattach the cover using the retained capscrews.

8. Reinstall the drain plug and open the strainer service valves.

9. Check for leakage.

10. Close the disconnect switches for the compressor and (if applicable) the oil pump motor starters.

11. Start the unit.

### SUCTION CHECK VALVE BYPASS

A 1/4" angle valve is installed between the compressor and suction flange that can be used as a suction valve bypass. This feature has several uses including reducing starting torque, improving oil quality, and relieving the refrigerant to low side for servicing.

In most cases, the valve should be left open approximately 1 to 2 turns at all times. If the compressor back-spins or too much oil foaming is experienced while venting, partially close valve to slow speed of equalization. If system is on AUTO CYCLE and short cycling occurs, the valve must be closed.

To relieve refrigerant to low side, close separator discharge service valve. Slowly open bypass valve (if closed) and wait for pressure to equalize. Close bypass and suction service valves before evacuating the unit.

## COALESCER FILTER ELEMENT

### CAUTION

Use of coalescer filter elements other than Frick may cause warranty claim to be denied.

When changing the coalescer filter element, it is recommended that the oil and oil filter be changed. Applicable strainer elements should be removed and cleaned.

1. Refer to **CHANGING OIL**, Steps 1 thru 8.
2. Remove coalescer head and gasket. Discard the gasket.
3. Remove and retain nut securing coalescer filter retainer.
4. Remove retainer, coalescer filter element(s), and two O-rings. Discard the filter element(s).
5. Install new coalescer filter element(s). **NOTE: Frick® Demistifier™ element (with drain feature), on Models 24–101, must be installed with the "DRAIN DOWN" tag on the bottom at the 6 o'clock position.**

### CAUTION

Seat element in center of locating tabs on separator bulkhead.

6. Replace coalescer filter retainer and nut. Tighten the nut to 21 ft/lb torque. **DO NOT OVERTIGHTEN NUT. Excessive torque can damage the element and result in oil carry-over.** Install jam nut and tighten.
7. Install a new head gasket and replace the coalescer head.
8. Tighten the head bolts, first to finger tight, then 65 ft-lb, then 130 ft-lb. **NOTE: WHEN THE COMPRESSOR UNIT IS REPRESSURIZED, RETIGHTEN SINCE HEAD BOLTS WILL LOOSEN.**
9. Refer to **CHANGING OIL**, Steps 9 thru 14.

## CHANGING OIL

### WARNING

**DO NOT MIX OILS** of different brands, manufacturers, or types. Mixing of oils may cause excessive

oil foaming, nuisance oil level cutouts, oil pressure loss, gas or oil leakage and catastrophic compressor failure.

### CAUTION

Use of oils other than Frick may cause warranty claim to be denied.

Shut down the unit when changing oil. At the same time all oil filter cartridges must be changed and all oil strainer elements removed and cleaned. The procedure is as follows:

1. Push **[STOP]** key to shut down the unit.
2. Open disconnect switch for the compressor motor starter.
3. Close liquid injection service valves (if applicable).
4. Close discharge service valve. **SLOWLY** vent the separator to low-side system pressure using the suction check valve bypass. Close suction valve. **NOTE: Recover or transfer all refrigerant vapor, in accordance with local ordinances, before opening to atmosphere.** The separator **MUST** be equalized to atmospheric pressure.

### CAUTION

Oil entrained refrigerant may vaporize, causing a separator pressure increase. Repeat venting and recovery procedure, if necessary.

5. Open drain valve(s) located on the underside of the separator and drain the oil.
6. Drain oil filter, strainers, and oil cooler, if applicable.
7. Remove and install new oil filter element.
8. Remove, clean, and reinstall strainer elements in strainers.
9. Evacuate unit to 29.88" Hg (1000 microns).
10. Open suction service valve and pressurize the unit to system suction pressure. Close the suction valve and leak test.
11. Add oil by attaching a suitable pressure-type hose to the oil-charging valve located on top of the separator. Using a pressure-type oil pump and recommended Frick oil, open the charging valve and fill the separator until oil level is midway in the top sight glass. **NOTE: Fill slowly because oil will fill up in the separator faster than it shows in the sight glass.** See Oil Charge section.
12. Open discharge and liquid injection service valves.
13. Close disconnect switch for compressor motor starter.
14. Start the unit.

## SUCTION STRAINER CLEANING PROCEDURE

1. Open disconnect switch.
2. Isolate the package by closing all package valves to the system. Tag all closed valves.

### CAUTION

Open any solenoid valves or other valves that may trap liquid between the isolation valves and

other package valves to prevent injury or damage to components.

3. With liquid injection, close the manual hand valve upstream of YY7 and manually open YY7 by turning in the manual opening stem (clockwise viewed from below valve).

### CAUTION

Failure to follow this procedure will damage valve YY7.

4. **SLOWLY** vent the separator to low-side system pressure using the suction check valve bypass. **NOTE: Recover or transfer all refrigerant vapor, in accordance with local ordinances, before opening to atmosphere.** The separator **MUST** be equalized to atmospheric pressure.

### CAUTION

Oil entrained refrigerant may vaporize, causing a separator pressure increase. Repeat transfer and recovery procedure, if necessary.

5. Remove cover plate.
6. Remove strainer.
7. Clean strainer.
8. Reinstall the strainer in the proper direction (outboard end is marked) and replace the gasket.

### CAUTION

If the strainer is installed backwards, it will be damaged.

9. Pressurize and leak test. Evacuate unit to 29.88" Hg (1000 microns).
10. First, reset solenoid valves to automatic position then open all valves previously closed. Remove tags. Close disconnect switches for compressor. Start unit.

**DEMAND PUMP DISASSEMBLY**

**⚠ DANGER** BEFORE OPENING ANY VIKING PUMP LIQUID CHAMBER (PUMPING CHAMBER, RESERVOIR, JACKET, ETC.) ENSURE:

**1. THAT ANY PRESSURE IN THE CHAMBER HAS BEEN COMPLETELY VENTED THROUGH SUCTION OR DISCHARGE LINES OR OTHER APPROPRIATE OPENINGS OR CONNECTIONS.**

**2. THAT THE DRIVING MEANS (MOTOR, TURBINE, ENGINE, ETC.) HAS BEEN “LOCKED OUT” OR MADE NONOPERATIONAL SO THAT IT CANNOT BE STARTED WHILE WORK IS BEING DONE ON THE PUMP.**

**FAILURE TO FOLLOW ABOVE LISTED PRECAUTIONARY MEASURES MAY RESULT IN SERIOUS INJURY OR DEATH.**

1. Mark head and casing before disassembly to ensure proper reassembly. The idler pin, which is offset in the pump head, must be positioned up and equal distance between port connections to allow for proper flow of liquid through the pump.

2. Remove the head capscrews.

3. Tilt top of head back when removing to prevent idler from falling off idler pin.

4. Remove idler and bushing assembly. If idler bushing needs replacing, see **INSTALLATION OF CARBON GRAPHITE BUSHINGS**.

5. Insert a brass bar or piece of hardwood in the port opening and between rotor teeth to keep shaft from turning. Turn the locknut counterclockwise and remove locknut. See Figure 20 or 21.

6. Loosen two setscrews in face of bearing housing and turn thrust bearing assembly counterclockwise and remove from casing. See Figure 20 or 21.

7. **GG, HJ, HL:** Remove snap ring from shaft. See Figure 20. **AS, AK, AL:** Remove bearing spacer from shaft. See Figure 21.

8. Remove brass bar or piece of hardwood from port opening.

9. The rotor and shaft can now be removed by tapping on end of shaft with a lead hammer or, if using a regular hammer, use a piece of hardwood between shaft and hammer.

The rotary member of the seal will come out with rotor and shaft.

10. **AS, AK, AL:** Remove bearing retainer washer. The washer may have stayed with rotor and shaft when removed or is against ball bearing. See Figure 21.

11. Remove the mechanical seal rotary member and spring from rotor and shaft assembly.

12. **GG, HJ, HL:** Remove inner snap ring and single-row ball bearing from casing.

**AS, AK, AL:** Remove single-row ball bearing from casing.

13. Remove seal seat or stationary part of seal from casing.

14. Disassemble thrust-bearing assembly.

**GG, HJ, HL:** Remove outer snap ring from bearing housing and remove ball bearing. See Figure 20.

**AS, AK, AL:** Loosen two set screws in flange outside diameter. Rotate end cap and lip seal counterclockwise and remove. Remove ball bearing. See Figure 21.

The casing should be examined for wear, particularly in the area between ports. All parts should be checked for wear before pump is put together.

When making major repairs, such as replacing a rotor and shaft, it is advisable to also install a new mechanical seal, head and idler pin, idler, and bushing. See **INSTALLATION OF CARBON-GRAPHITE BUSHINGS**.

Clean all parts thoroughly and examine for wear or damage. Check lip seals, ball bearings, bushing, and idler pin and replace if necessary. Check all other parts for nicks, burrs, excessive wear and replace if necessary.

Wash bearings in clean solvent. Blow out bearings with compressed air. Do not allow bearings to spin; turn them slowly by hand. Spinning bearings will damage race and balls. Make sure bearings are clean, then lubricate with refrigeration oil and check for roughness. Roughness can be determined by turning outer race by hand. Replace bearings if bearings have roughness.

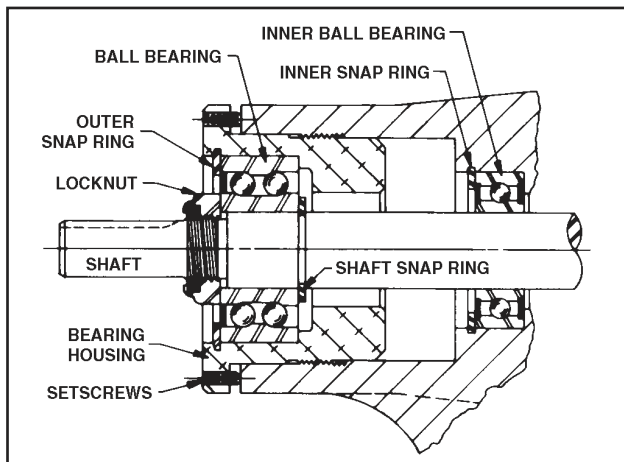

**Figure 20 - Thrust-Bearing assembly (GG, HJ, HL)**

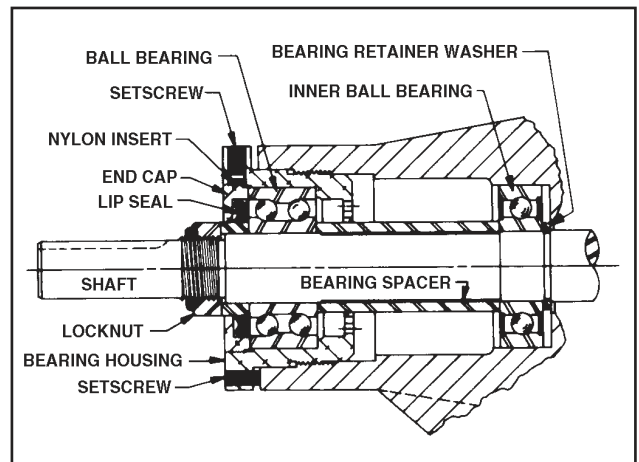

**Figure 21 - Thrust-Bearing assembly (AS, AK, AL)**

Be sure shaft is free from nicks, burrs and foreign particles that might damage mechanical seal. Scratches on shaft in seal area will provide leakage paths under mechanical seal. Use fine emery cloth to remove scratches or sharp edges.

### DEMAND PUMP ASSEMBLY

Assembly Notes On Standard Mechanical Seal (Synthetic Rubber Bellows Type)

**NOTE: Read carefully before reassembling pump**

The seal used in this pump is simple to install and good performance will result if care is taken during installation.

The principle of mechanical seal is contact between the rotary and stationary members. These parts are lapped to a high finish and their sealing effectiveness depends on complete contact.

Prior to installing rotary portion of mechanical seal, prepare and organize rotor shaft, head and idler assemblies and appropriate gaskets for quick assembly

Once rotary portion of mechanical seal is installed on rotor shaft, it is necessary to assemble parts as quickly as possible to ensure that the seal does not stick to shaft in wrong axial position. The seal will stick to the shaft after several minutes setting time.

Never touch sealing faces with anything except clean hands or clean cloth. Minute particles can scratch the seal faces and cause leakage.

1. Coat idler pin with refrigeration oil and place idler and bushing on idler pin in head. If replacing a carbon-graphite bushing, refer to "Installation of Carbon Graphite Bushings".
2. Clean rotor hub and casing seal housing bore. Make sure both are free from dirt and grit. Coat outer diameter of seal seat and inner diameter of seal housing bore with refrigeration oil.
3. Start seal seat in seal housing bore. If force is necessary, protect seal face with a clean cardboard disc and gently tap it in place with a piece of wood. Be sure seal seat is completely seated in the bore.
4. Place tapered installation sleeve on shaft. Refer to Figure 22. Sleeve is furnished with GG, AS, AK, and AL replacement mechanical seals. Coat rotor shaft, tapered installation sleeve, and inner diameter of mechanical seal rotary member with a generous amount of refrigeration oil. Petrolatum may be used but grease is not recommended.

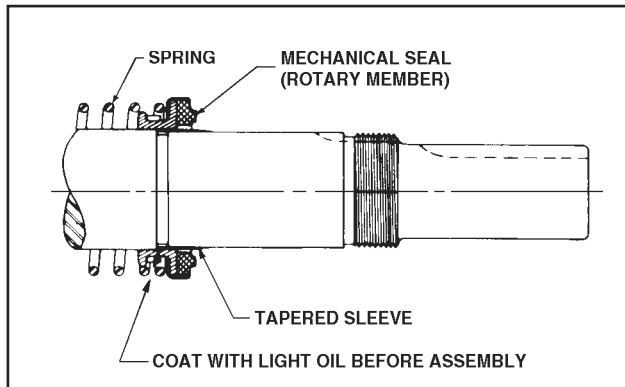

Figure 22

5. Place seal spring on shaft against rotor hub. Refer to Figure 23.

6. Slide rotary member, with lapped contact surface facing away from spring, over installation sleeve on shaft until just contacting the spring. Do not compress spring. Remove installation sleeve.

7. Coat rotor shaft with refrigeration oil. Install shaft slowly pushing until the ends of rotor teeth are just below the face of the casing.

8. Leave the rotor in this position. Withdrawal of rotor and shaft may displace the carbon seal rotating face and result in damage to the seal.

9. Place O-ring gasket on head and install head and idler assembly on pump. Pump head and casing were marked before disassembly to ensure proper reassembly. If not, be sure idler pin, which is offset in pump head, is positioned up and equal distance between port connections to allow for proper flow of liquid through pump.

10. Tighten head capscrews evenly

11. Pack inner ball bearing with multipurpose grease, NLGI #2.

**GG, HJ, HL:** Install bearing in casing with sealed side towards head end of pump. Drive the bearing into the bore. Tap the inner race with a brass bar and lead hammer to position bearing. Install inner snap ring.

**AS, AK, AL:** Install bearing retainer washer over the shaft before installing ball bearing. Install ball bearing in casing with sealed side towards head end of pump. Drive the bearing into the bore. Tap the inner race with a brass bar and lead hammer to position bearing.

12. **GG, HJ, HL:** Install shaft snap ring in groove in the shaft. See Figure 20.

**AS, AK, AL:** Install bearing spacer over shaft and against single row ball bearing. See Figure 21.

13. **Pack lubrication chamber between** inner ball bearing and double-row ball bearing in the thrust-bearing assembly approximately one-half full of multipurpose grease, NLGI #2. The thrust-bearing assembly will take the remaining space. See Figure 20 and 21.

14. Pack double-row ball bearing with multipurpose grease, NLGI #2.

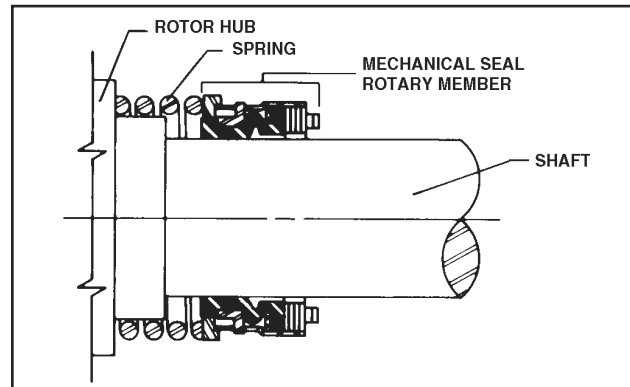

Figure 23

**GG, HJ, HL:** Install ball bearing into bearing housing with shield side toward coupling end of shaft. See Figure 22. Install snap ring into bearing housing to retain ball bearing. This snap ring has a tapered edge to fit tapered groove in bearing housing. The tapered edge is located away from ball bearing.

**AS, AK, AL:** Install ball bearing into bearing housing. Install lip seal in bearing housing end cap. The lip should face towards end of shaft. Put bearing spacer collar in lip seal and install in bearing housing and tighten setscrews securely. See Figure 21.

15. Insert brass bar or hardwood through port opening between rotor teeth to keep shaft from turning.

16. Start thrust-bearing assembly into casing. Turn by hand until tight. This forces rotor against head. Replace and tighten locknut or shaft.

17. Remove brass bar or hardwood from port opening.

18. Adjust pump end clearance.

**⚠ DANGER** BEFORE STARTING PUMP, ENSURE THAT ALL DRIVE EQUIPMENT GUARDS ARE IN PLACE. FAILURE TO PROPERLY MOUNT GUARDS MAY RESULT IN SERIOUS INJURY OR DEATH.

### THRUST BEARING ADJUSTMENT

See Figures 20 and 21.

Loosen two screws in face of thrust-bearing assembly.

If shaft cannot be rotated freely, turn thrust-bearing assembly counterclockwise until shaft can be turned easily.

1. While turning rotor shaft, rotate thrust-bearing assembly clockwise until noticeable drag occurs. This is zero end clearance.

2. Mark position of bearing housing with respect to the casing.

3. Rotate thrust-bearing assembly counterclockwise the distance listed below as measured on outside of bearing housing.

4. Tighten two setscrews in face of bearing housing after adjustment is made to secure thrust-bearing assembly position.

For viscosities above 2500 SSU, add additional end clearance (0.004" for GG, HJ and HL size pumps and 0.005" for AS, AK and AL size pumps).

Pump Size	Distance (in.) on O.D. of Bearing Housing	End Clearance (in.)
GG	7/16	.003
HJ, HL	9/16	.003
AS, AK, AL	1/2	.003

### INSTALLATION OF CARBON GRAPHITE BUSHINGS

When installing carbon graphite bushings, extreme care must be taken to prevent breaking. Carbon graphite is a brittle material and easily cracked. If cracked, the bushing will quickly disintegrate. Using a lubricant and adding a chamfer on the bushing and the mating part will help in installation. The additional precautions listed below must be followed for proper installation:

1. A press must be used for installation.
2. Be certain bushing is started straight.
3. Do not stop pressing operation until bushing is in proper position. Starting and stopping will result in a cracked bushing.
4. Check bushing for cracks after installation.

### TROUBLESHOOTING THE DEMAND PUMP

**⚠ DANGER** BEFORE OPENING ANY PUMP LIQUID CHAMBER (PUMPING CHAMBER, RESERVOIR, JACKET ETC.) ENSURE:

1. THAT ANY PRESSURE IN CHAMBER HAS BEEN COMPLETELY VENTED THROUGH SUCTION OR DISCHARGE LINES OR OTHER APPROPRIATE OPENINGS OR CONNECTIONS.

2. THAT THE DRIVING MEANS (MOTOR, TURBINE, ENGINE, ETC.) HAS BEEN "LOCKED OUT" OR MADE NONOPERATIONAL SO THAT IT CANNOT BE STARTED WHILE WORK IS BEING DONE ON PUMP.

**FAILURE TO FOLLOW ABOVE LISTED PRECAUTIONARY MEASURES MAY RESULT IN SERIOUS INJURY OR DEATH.**

Mark valve and head before disassembly to ensure proper reassembly.

If trouble does develop, one of the first steps toward finding the difficulty is to *install a vacuum gauge in the suction port and a pressure gauge in the discharge port*. Readings on these gauges often will give a clue as to where to start looking for the trouble.

#### Vacuum Gauge—Suction Port

1. High reading would indicate:
  - a. Suction line blocked - foot valve stuck, gate valve closed, strainer plugged.
  - b. Liquid too viscous to flow through the piping.
  - c. Lift too high.
  - d. Line too small.
2. Low reading would indicate -
  - a. Air leak in suction line.
  - b. End of pipe not in liquid.
  - c. Pump is worn.
  - d. Pump is dry - should be primed.
3. Fluttering, jumping, or erratic reading:
  - a. Liquid vaporizing.
  - b. Liquid coming to pump in slugs - possibly an air leak or insufficient liquid above the end of the suction pipe.
  - c. Vibrating from cavitation, misalignment, or damaged parts.

### Pressure Gauge - Discharge Port

1. High reading would indicate:
  - a. High viscosity and small and/or long discharge line.
  - b. Gate valve partially closed.
  - c. Filter plugged.
  - d. Vertical head did not consider a high specific gravity liquid.
  - e. Line partially plugged from buildup on inside of pipe.
  - f. Liquid in pipe not up to temperature.
  - g. Liquid in pipe has undergone a chemical reaction and has solidified.
  - h. Relief valve set too high.
2. Low reading would indicate:
  - a. Relief valve set too low
  - b. Relief valve poppet not seating properly.
  - c. Too much extra clearance.
  - d. Pump worn.
3. Fluttering, jumping, or erratic reading:
  - a. Cavitation.
  - b. Liquid coming to pump in slugs.
  - c. Air leak in suction line.
  - d. Vibrating from misalignment or mechanical problems.

### Some of the following may also help pinpoint the problem:

1. Pump does not pump.
  - a. Lost its prime - air leak, low level in tank.
  - b. Rotating in wrong direction.
  - c. Motor does not come up to speed.
  - d. Suction and discharge valves not open.
  - e. Strainer clogged.
  - f. Relief valve set too low, relief valve poppet stuck open.
  - g. Pump worn out.
  - h. Any changes in the liquid system, or operation that would help explain the trouble, e.g. new source of supply, added more lines, inexperienced operators, etc.
  - i. Tighten end clearance.
  - j. Head position incorrect.
2. Pump starts, then loses its prime.
  - a. Low level in tank.
  - b. Liquid vaporizing in the suction line.
  - c. Air leaks or air pockets in the suction line; leaking air through packing or mechanical seal.
  - d. Worn out.
3. Pump is noisy
  - a. Pump is being starved (heavy liquid cannot get to pump fast enough). Increase suction pipe size or reduce length.
  - b. Pump is cavitating (liquid vaporizing in the suction line). Increase suction pipe size or reduce length; if pump is above the liquid, raise the liquid level closer to the pump; if the liquid is above the pump, increase the head of liquid.
  - c. Check alignment.
  - d. May have a bent shaft or rotor tooth. Straighten or replace.
  - e. May be a foreign object trying to get into the pump through the suction port.
4. Pump not up to capacity
  - a. Starving or cavitating - increase suction pipe size or reduce length.
  - b. Strainer partially clogged - clean.
  - c. Air leak in suction piping or along pump shaft.
  - d. Running too slowly - is motor the correct speed and is it wired up correctly
  - e. Relief valve set too low or stuck open.
  - f. Pump worn out.

- g. Tighten end clearance.
- h. Head position incorrect.

5. Pump takes too much power.
  - a. Running too fast - is correct motor speed, reducer ratio, sheave size, etc. being used.
  - b. Liquid more viscous than unit sized to handle - heat the liquid, increase the pipe size, slow the pump down, or get a bigger motor.
  - c. Discharge pressure higher than calculated - check with pressure gauge. Increase size or reduce length of pipe, reduce speed (capacity), or get bigger motor.
  - d. Pump misaligned.
  - e. Extra clearance on pumping elements may not be sufficient for operating conditions. Check parts for evidence of drag or contact in pump and increase clearance where necessary

### 6. Rapid Wear.

Examination of a pump that has gradually lost its ability to deliver capacity or pressure would show a smooth wear pattern on all parts. Rapid wear shows up as heavy grooving, galling, twisting, breaking, or similar severe signs of trouble.

## RECOMMENDED MAINTENANCE PROGRAM

In order to obtain maximum compressor unit performance and ensure reliable operation, a regular maintenance program should be followed (see Maintenance Schedule):

The compressor unit should be checked daily for leaks, abnormal vibration, noise, and proper operation. A daily log should also be maintained. There should be a continued monitoring of oil quality and oil analysis testing. In addition, an analysis of the unit's vibration should be made periodically.

## VIBRATION ANALYSIS

Periodic vibration analysis can be useful in detecting bearing wear and other mechanical failures. If vibration analysis is used as a part of your preventive maintenance program, take the following guidelines into consideration.

1. Always take vibration readings from exactly the same places, at exactly the same percent of load.
2. Use vibration readings taken from the new unit at start-up as the base line reference.
3. Evaluate vibration readings carefully as the instrument range and function used can vary. Findings can be easily misinterpreted.
4. Vibration readings can be influenced by other equipment operating in the vicinity or connected to the same piping as the unit. For additional information, request Frick® publication E70-902 IB.

## OIL QUALITY and ANALYSIS

High quality refrigeration oil is necessary to ensure compressor longevity and reliability. Oil quality will rapidly deteriorate in refrigeration systems containing moisture and air or other contaminants. In order to ensure the quality of the refrigeration oil in the compressor unit:

1. Only use Frick® refrigeration oil and filter elements or warranty claim may be denied.
2. Participate in a regular, periodic oil analysis program to maintain oil and system integrity.

### MOTOR BEARINGS



Lubricate motor bearings properly before start-up. Maintain subsequent lubrication as recommended

by the motor manufacturer. See Figure 24.

### OPERATING LOG

The use of an operating log, as shown in this manual (see Table of Contents), permits thorough analysis of the operation of a refrigeration system by those responsible for its maintenance and servicing. Continual recording of gauge pressures, temperatures, and other pertinent information enables the

observer and serviceman to be constantly familiar with the operation of the system and to recognize immediately any deviations from normal operating conditions. It is recommended that readings be taken at least every four hours.

### TROUBLESHOOTING GUIDE

Successful problem solving requires an organized approach to define the problem, identify the cause, and make the proper correction. Sometimes it is possible that two relatively obvious problems combine to provide a set of symptoms that can mislead the troubleshooter. Be aware of this possibility and avoid solving the "wrong problem".

## LUBRICATION SCHEDULE / INSTRUCTIONS

SYNC. RPM	FRAME SERIES	SERVICE CYCLE* - BALL BEARING**	
		8 HR/DAY OPERATION	24 HR/DAY OPERATION
3600	360-5800	150 DAYS (1200 HRS)	50 DAYS (1200 HRS)
1800	360	390 DAYS (3120 HRS)	130 DAYS (3120 HRS)
	400-440	270 DAYS (2160 HRS)	90 DAYS (2160 HRS)
	5000-5800	210 DAYS (1680 HRS)	70 DAYS (1680 HRS)
1200	360-440	390 DAYS (3120 HRS)	130 DAYS (3120 HRS)
	5000-5800	270 DAYS (2160 HRS)	90 DAYS (2160 HRS)

- LUBRICATE BEARINGS WITH POWER IN THE OFF CONDITION.
- CLEAR AND CLEAN THE GREASE FITTINGS AND SURROUNDING AREA.
- REMOVE THE PIPE PLUG FROM THE VENTING PORT OPPOSITE THE GREASE FITTING.
- USING A LOW PRESSURE GREASE GUN APPLY 1 OZ. (30 GRAMS) OF GREASE AT EACH FITTING. DO NOT OVERGREASE.
- WITH THE VENT PORTS OPEN, OPERATE THE MOTOR FOR A MINIMUM OF 15 MINUTES AND UNTIL ANY GREASE FLOW HAS CEASED AT THE VENTING PORTS.
- REMOVE POWER.
- REPLACE THE VENT PIPE PLUGS.
- REPLACE ANY AND ALL GUARDS AND COVERS THAT MAY HAVE BEEN REMOVED TO ACCESS THE MOTOR.

\* LUBRICATION SCHEDULE FOR SEVERE SERVICE (VIBRATION, SHOCK AND/OR ENVIRONMENTAL EXTREME) = 1/3 OF THE ABOVE INTERVALS.

\*\* LUBRICATION SCHEDULE FOR ROLLER BEARINGS = 1/3 OF ABOVE INTERVALS.

THE FACTORY INSTALLED, RECOMMENDED LUBRICANT IS LISTED ON THE MOTOR DATA PLATE. THIS IS A POLYUREA GREASE, AS ARE THE PRODUCTS LISTED BELOW. THE INTRODUCTION OF LUBRICANTS OF ALTERNATE CHEMICAL MAKEUP IS NOT RECOMMENDED AND WILL CAUSE MECHANICAL FAILURE WITHOUT THE COMPLETE PURGE OF THE FACTORY PRODUCT FROM THE BEARING AND RESERVOIR. WHEREVER POSSIBLE, APPLY THE POLYUREA PRODUCT.

CHEVRON OIL CO. - SRI#2 MOBILE POLYREX EM

Figure 24

### MAINTENANCE SCHEDULE

This schedule should be followed to ensure trouble-free operation of the compressor unit.

MAINTENANCE	FREQUENCY OR HOURS OF OPERATION (MAXIMUM)																						
	200	1000	5000	8000	10,000	15,000	20,000	25,000	30,000	35,000	40,000	45,000	50,000	55,000	60,000	65,000	70,000	75,000	80,000	85,000	90,000	95,000	
Change Oil	As Directed By Oil Analysis																						
Oil Analysis		■																					
Replace Filters	■		■		■		■		■		■		■		■		■		■		■		■
Clean Oil Strainers	■		■		■		■		■		■		■		■		■		■		■		■
Clean Liquid Strainers	■		■		■		■		■		■		■		■		■		■		■		■
Replace Coalescers									■						■								■
Check and Clean Suction Strainer	■		■		■		■		■		■		■		■		■		■		■		■
Check Coupling (a)	■	Annually Regardless of Operating Hours																					
Check Electrical Connections (b)	■		■		■		■		■		■		■		■		■		■		■		■
Check Sensor Calibration (c)	■	■	■		■	■	■	■	■	■	■	■	■	■	■	■	■	■	■	■	■	■	■
Vibration Analysis	■	Every 6 Months, More Frequently If Levels Increase																					
Replace Shaft Seal	When Leak Rate Exceeds 7 - 8 Drops Per Minute																						

- Check bolts, shim packs, center inserts, keys, and all bolt torques.
- Check and torque all terminals in the processor and starter panel per the specification posted in the enclosure.
- Check calibration of Slide Valve, Slide Stop, pressures and temperatures.

## ABNORMAL OPERATION ANALYSIS and CORRECTION

Four logical steps are required to analyze an operational problem effectively and make the necessary corrections:

1. Define the problem and its limits.
2. Identify all possible causes.
3. Test each cause until the source of the problem is found.
4. Make the necessary corrections.

The first step in effective problem solving is to define the limits of the problem. If, for example, the compressor periodically experiences high oil temperatures, do not rely on this observation alone to help identify the problem. On the basis of this information, the apparent corrective measure would appear to be a readjustment of the liquid injection system. Lowering the equalizing pressure on the thermal expansion valve would increase the refrigerant feed and the oil temperature should drop.

If the high oil temperature was the result of high suction superheat, however, and not just a matter of improper liquid injection adjustment, increasing the liquid feed could lead to other problems. Under low load conditions the liquid injection system may have a tendency to overfeed. The high suction superheat condition, moreover, may only be temporary. When system conditions return to normal, the unit's liquid injection will overfeed and oil temperature will drop. In solving the wrong problem a new problem was created.

The following list of abnormal system conditions can cause abnormal operation of the **RXF** compressor unit:

1. Insufficient or excessive refrigeration load.
2. Excessively high suction pressure.
3. Excessively high suction superheat.
4. Excessively high discharge pressure.
5. Inadequate refrigerant charge or low receiver level.
6. Excessively high or low temperature coolant to the oil cooler.
7. Liquid return from system (carryover).
8. Refrigerant underfeed or overfeed to evaporators.
9. Blocked tubes or plates in water-cooled oil cooler from high mineral content of water.
10. Insufficient evaporator or condenser sizing.
11. Incorrect refrigerant line sizing.
12. Improper system piping.
13. Problems in electrical service to compressor unit.
14. Air and moisture present in the system.

Make a list of all deviations from normal plant operation and normal compressor unit operation. Delete any items which do not relate to the symptom and separately list those items that might relate to the symptom. Use the list as a guide to further investigate the problem.

The second step in problem solving is to decide which items on the list are possible causes and which items are additional

symptoms. High discharge temperature and high oil temperature readings may both be symptoms of a problem and not casually related. High suction superheat or a low receiver level, however, could cause both symptoms.

The third step is to identify the most likely cause and take action to correct the problem. If the symptoms are not relieved, move to the next item on the list and repeat the procedure until you have identified the cause of the problem. Once the cause has been identified and confirmed, make the necessary corrections.

## PRESSURE TRANSDUCERS - TESTING

Test Procedure:

1. Shut compressor down and allow pressures to equalize.
2. Isolate suction transducer (PE-4) from unit and depressurize. **NOTE: Recover or transfer all refrigerant vapor, in accordance with local ordinances, before opening to atmosphere.**
3. Measure the DC voltage of (PE-4) on connector (P6A) (terminals 2 and 3) on the analog board with a digital voltmeter.
4. The voltage reading should be between 1.48 VDC and 1.72 VDC at standard atmospheric pressure (14.7 PSIA or 0 PSIG). When checking transducers at higher elevations, an allowance in the readings must be made by subtracting approximately 0.02 VDC per 1000 feet of elevation above sea level. Barometric pressure can generally be ignored but in extreme cases may be compensated for by adding/subtracting 0.002 VDC for each 0.1 inch of barometric pressure (adjusted to sea level) above/below 0 PSIG. Therefore, if (PE-4) is measured at 5000 feet elevation under relatively normal weather conditions, the output voltage should differ by 0.10 VDC to read between 1.38 VDC and 1.62 VDC.
5. Subtract 1 from the voltage.
6. Multiply by 25.
7. This result is the absolute suction pressure (PSIA). Subtract 14.7 to obtain PSIG which the Operating display will indicate.
8. Isolate the oil pressure transducers (PE-1 & PE-2) from the package and depressurize. **NOTE: Recover or transfer all refrigerant vapor, in accordance with local ordinances, before opening to atmosphere.**
9. Measure the voltage of (PE-1 & PE-2) on connector (P5A) (terminals 5 and 6) on the analog board.
10. The voltage reading should be between 1.1 VDC and 1.29 VDC at standard atmospheric pressure. (PE-1 & PE-2) and (PE-3) have a span of 500 PSI as compared to (PE-4) with a span of 200 PSI. Therefore, atmospheric pressure changes have a lesser effect which is 0.0067 VDC per 1000 feet of elevation and 0.00067 VDC per 0.1 inch Hg barometric deviation.
11. Subtract 1.2 from the voltage.
12. Multiply by 75, the result will be PSIG.
13. Since the discharge pressure (PE-3) cannot be closed off from its sensing point (code requirements), remove all transducers from atmosphere and open them to their sensing points so all transducers can equalize to separator pressure.

<b>PRESSURE TRANSDUCER CONVERSION DATA</b>								
<b>Sensor Voltage</b>	<b>100 psi</b>		<b>200 psi</b>		<b>300 psi</b>		<b>500 psi</b>	
	<b>Range - PSIG*</b>		<b>Range - PSIG*</b>		<b>Range - PSIG*</b>		<b>Range - PSIG*</b>	
	<b>low</b>	<b>high</b>	<b>low</b>	<b>high</b>	<b>low</b>	<b>high</b>	<b>low</b>	<b>high</b>
1.0	29.92"	19.74"	29.92"	9.57"	29.92"	7.0"	29.92"	4.10
1.1	29.92"	14.65"	29.92"	0.30	29.92"	4.10	29.92"	16.60
1.2	29.92"	9.57"	29.92"	5.30	22.3"	11.60	17.1"	29.10
1.3	24.83"	4.48"	19.74"	10.30	7.0"	19.10	4.10	41.60
1.4	19.74"	0.30	9.57"	15.30	4.10	26.60	16.60	54.10
1.5	14.65"	2.80	0.30	20.30	11.60	34.10	29.10	66.60
1.6	9.57"	5.30	5.30	25.30	19.10	41.60	41.60	79.10
1.7	4.48"	7.8	10.3	30.30	26.60	49.10	54.10	91.60
1.8	0.30	10.30	15.30	35.30	34.10	56.60	66.60	104.10
1.9	2.80	12.80	20.30	40.30	41.60	64.10	79.10	116.60
2.0	5.30	15.30	25.30	45.30	49.10	71.60	91.60	129.10
2.1	7.80	17.80	30.30	50.30	56.60	79.10	104.10	141.60
2.2	10.30	20.30	35.30	55.30	64.10	86.60	116.60	154.10
2.3	12.80	22.80	40.30	60.30	71.60	94.10	129.10	166.60
2.4	15.30	25.30	45.30	65.30	79.10	101.60	141.60	179.10
2.5	17.80	27.80	50.30	70.30	86.60	109.10	154.10	191.60
2.6	20.30	30.30	55.30	75.30	94.10	116.60	166.60	204.10
2.7	22.80	32.80	60.30	80.30	101.60	124.10	179.10	216.60
2.8	25.30	35.30	65.30	85.30	109.10	131.60	191.60	229.10
2.9	27.80	37.80	70.30	90.30	116.60	139.10	204.10	241.60
3.0	30.30	40.30	75.30	95.30	124.10	146.60	216.60	254.10
3.1	32.80	42.80	80.30	100.30	131.60	154.10	229.10	266.60
3.2	35.30	45.30	85.30	105.30	139.10	161.60	241.60	279.10
3.3	37.80	47.80	90.30	110.30	146.60	169.10	254.10	291.60
3.4	40.30	50.30	95.30	115.30	154.10	176.60	266.60	304.10
3.5	42.80	52.80	100.30	120.30	161.60	184.10	279.10	316.60
3.6	45.30	55.30	105.30	125.30	169.10	191.60	291.60	329.10
3.7	47.80	57.80	110.30	130.30	176.60	199.10	304.10	341.60
3.8	50.30	60.30	115.30	135.30	184.10	206.60	316.60	354.10
3.9	52.80	62.80	120.30	140.30	191.60	214.10	329.10	366.60
4.0	55.30	65.30	125.30	145.30	199.10	221.60	341.60	379.10
4.1	57.80	67.80	130.30	150.30	206.60	229.10	354.10	391.60
4.2	60.30	70.30	135.30	155.30	214.10	236.60	366.60	404.10
4.3	62.80	72.80	140.30	160.30	221.60	244.10	379.10	416.60
4.4	65.30	75.30	145.30	165.30	229.10	251.60	391.60	429.10
4.5	67.80	77.80	150.30	170.30	236.60	259.10	404.10	441.60
4.6	70.30	80.30	155.30	175.30	244.10	266.60	416.60	454.10
4.7	72.80	82.80	160.30	180.30	251.60	274.10	429.10	466.60
4.8	75.30	85.30	165.30	185.30	259.10	281.60	441.60	479.10
4.9	77.80	87.80	170.30	190.30	266.60	289.10	454.10	491.60
5.0	80.30	90.30	175.30	195.30	274.10	296.60	466.60	504.10
<b>At 0 psig</b>	<b>1.388 V</b>	<b>1.788 V</b>	<b>1.094 V</b>	<b>1.494 V</b>	<b>1.046 V</b>	<b>1.346 V</b>	<b>0.968 V</b>	<b>1.268 V</b>

\* Below 0 PSIG measured in inches of mercury.

14. Measure the voltage of (PE-3) on connector (P5B) (terminals 5 and 6) on the analog board.

15. Test complete.

<b>TRANSDUCER</b>	<b>CONNECTION</b>
Suction Pressure	PE-4
Discharge Pressure	PE-3
Oil Pressure	PE-1 & PE-2

## PRESSURE TRANSDUCERS REPLACEMENT

1. Shut off control power.

2. Close the applicable transducer isolation valve. **NOTE: To change the discharge pressure transducer (PE-3), it will be necessary to depressurize the entire compressor package. Follow "General Instructions For Replacing Compressor Unit Components" section before going to step 3.**

3. Remove DIN connector screw, then remove DIN connector from the transducer.

4. Unscrew the transducer using a wrench on the metal hex at the base of the transducer. **DO NOT ATTEMPT TO LOOSEN OR TIGHTEN TRANSDUCERS BY THEIR TOP CASING.**

5. Install new transducer, reconnect DIN connector, and retighten DIN connector screw.

6. Recalibrate. **NOTE: If replacing older hard-wired transducer, cut cable at back of old transducer and rewire to the Danfoss unit.**

7. Reopen the transducer isolation valve or compressor package isolation valves.

8. Turn on control power.

## SLIDE VALVE TRANSMITTER REPLACEMENT - SLIDE STOP

The SLIDE VALVE Transmitter is located on the right side of the compressor (facing shaft) at the inlet end.

The linear transmitter with hermetic enclosure is based on the inductive measuring principle. It features removable electronics (from the sensor well) eliminating the need to evacuate the compressor for replacement. This type of transmitter is dedicated to volume ratio control and has no user adjustments.

1. Shut off control power.
2. Remove DIN connector plug from transmitter.
3. Loosen set screws.
4. Remove transmitter unit.
5. Install new transmitter unit.
6. Tighten set screws.
7. Apply DIN connector plug to transmitter.
8. Turn on control power.

**NOTE: For calibration of the Slide Valve unit, refer to the Analog Calibration instructions in publication S90-020 O.**

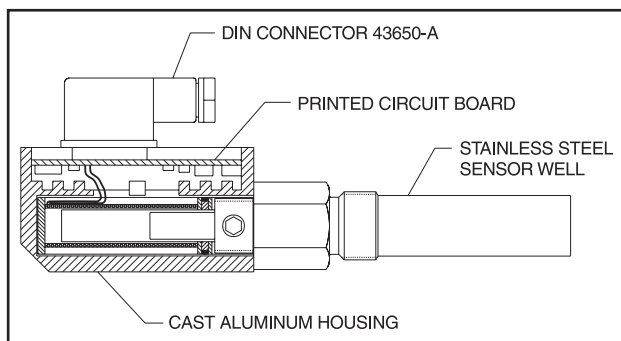

Figure 25 - SLIDE VALVE TRANSMITTER

## TEMPERATURE SENSOR REPLACEMENT



This device is static sensitive. Please follow proper ESD procedures when handling.

1. Shut off control power.
2. Remove DIN connector plug from transmitter. See Figure 26.
3. Unscrew knurled ring and remove transmitter unit.
4. Apply thermal compound to new sensor assembly, insert into thermal well, and tighten knurled ring.
5. Apply DIN connector plug to transmitter.
6. Turn on control power.

**NOTE: For calibration instructions, refer to Quantum™ LX Operator's Manual S90-020 O, -021 O, -022 O.**

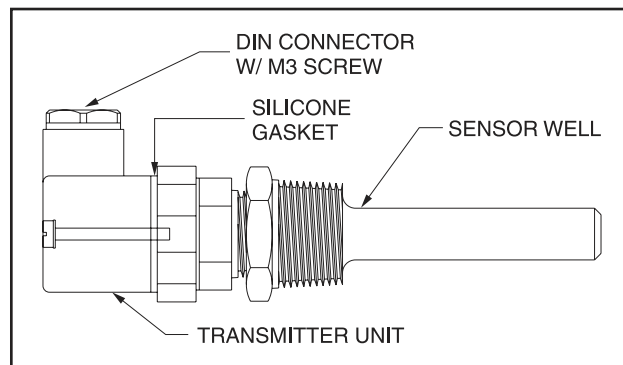

Figure 26 - Temperature Transmitter

## OIL LEVEL TRANSMITTER REPLACEMENT

The Oil Level Transmitter is located on the front of the separator near the bottom/center. See Figure 27.

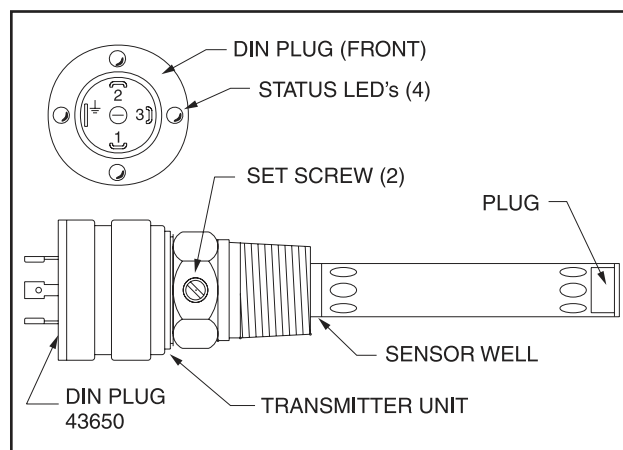

Figure 27 - Oil Level Transmitter

The linear transmitter with hermetic enclosure is based on the capacitive measuring principle. It features removable electronics (from the sensor well) eliminating the need to evacuate the compressor for replacement. This transmitter is dedicated to oil level control and has no user adjustments.



If it is necessary to replace the well, the separator must be purged and the oil drained. Refer to the section "CHANGING OIL."

1. Shut off control power.
2. Remove DIN connector plug from transmitter.
3. Loosen set screws.
4. Remove transmitter unit.
5. Install new transmitter unit.
6. Tighten set screws.
7. Apply DIN connector plug to transmitter.
8. Turn on control power.

**TEMPERATURE and/or PRESSURE  
ADJUSTMENT**

All temperature and pressure sensors are factory set. If calibration is required, refer to Analog Calibration for temperature or pressure in QUANTUM™LX publication S90-021 O or S90-022 O.

**BARE COMPRESSOR MOUNTING**

Refer to publication S70-660 SM.

**TROUBLESHOOTING THE COMPRESSOR**

SYMPTON	PROBABLE CAUSES and CORRECTIONS
EXCESSIVE NOISE and VIBRATION	<p>Loose bolts on compressor mounting. Tighten bolts.</p> <p>No oil getting to compressor. Check oil level, oil filter and oil pressure.</p> <p>Bearing damage or excessive wear.</p> <p>Coupling loose on shaft. Tighten coupling. Replace if damaged.</p> <p>Volumizer not adjusted correctly. Readjust.</p> <p>Refrigerant flood-back. Correct system problem.</p>

**TROUBLESHOOTING THE OIL SEPARATOR**

SYMPTON	PROBABLE CAUSES and CORRECTIONS
GRADUAL OIL LOSS WITH AN OIL LEVEL IN THE COALESCER SECTION SIGHT GLASS	<p>Maintaining too high an oil level. Lower level.</p> <p>Refrigerant carryover or liquid injection overfeeding. Correct operation.</p> <p>Contaminated oil or damaged coalescer filter elements. Replace oil charge and coalescers.</p> <p>Coalescers may be loose. Tighten.</p> <p>Oil return valve closed. Open return valve.</p> <p>Return oil strainer blocked. Clean strainer.</p>
RAPID LOSS WITH NO OIL LEVEL IN THE COALESCER SECTION SIGHT GLASS	<p>Compressor unit suction check valve did not close on shutdown. Repair valve.</p> <p>Bypass open around suction check valve. Close bypass valve.</p> <p>Bypass valve opened too far. Tighten</p> <p>Coalescer filter elements not seated properly. Replace oil charge and coalescers.</p> <p>Oil viscosity too low. Verify correct oil, replace if incorrect.</p> <p>High system CFM. System operating out of design conditions (High suction and Low discharge pressures).</p> <p>Refrigerant flood-back. Correct system problem.</p> <p>Two or more compressors piped to a single economizer vapor port. Verify check valves are in working order.</p>



**TROUBLESHOOTING THE LIQUID INJECTION OIL COOLING SYSTEM**

SYMPTOM	PROBABLE CAUSES and CORRECTIONS
HIGH OIL TEMPERATURE	<p>Insufficient liquid supply. Check receiver level. Check strainer.</p> <p>Suction superheat too high. Correct system problem.</p> <p>Liquid strainer blocked. Clean strainer.</p> <p>Operating conditions significantly different from design.</p> <p>Malfunctioning Vi Control Solenoids. See function check of the compressor "Volumizer II Vi Control" for further detail.</p> <p>Check motor valve operation and calibration.</p> <p>Check calibration of analog output.</p>
LOW OIL TEMPERATURE	<p>Equalizing pressure too low. Raise pressure.</p> <p>Suction superheat too low or refrigerant flood back on compressor. Correct system problem.</p> <p>Operating conditions significantly different from design.</p> <p>Check motor valve operation and calibration.</p> <p>Check calibration of analog output.</p>
OIL TEMPERATURE FLUCTUATES	<p>System conditions rapidly fluctuate causing liquid injection system to overrespond. Stabilize system operation.</p> <p>Check calibration and operation of motor valve - Adjust P &amp; ID setpoints for analog output.</p>

**TROUBLESHOOTING THE HYDRAULIC SYSTEM**

SYMPTOM	PROBABLE CAUSES and CORRECTIONS
SLIDE VALVE WILL NOT LOAD OR UNLOAD	<p>Solenoid coil burned out. Replace coil.</p> <p>HV2 needle valve closed. Open valve.</p> <p>Solenoid spool may be stuck or centering spring broken. Free spool or replace spring.</p> <p>Solenoid may be mechanically actuated by inserting a piece of 3/16" rod against armature pin and pushing spool to opposite end. Push "A" side to confirm unload capability. If valve works, problem is electrical.</p> <p>Solenoid valve piston hung in bore or bolt loose. Check piston or tighten bolt.</p>
SLIDE VALVE WILL LOAD BUT WILL NOT UNLOAD	<p>YY1 solenoid coil burned out. Replace coil.</p> <p>Check valve in solenoid valve piston bad. Replace or repair.</p> <p>Dirt inside solenoid valve preventing valve from operating both ways. Clean valve.</p> <p>Solenoid may be mechanically actuated by inserting a piece of 3/16" rod against armature pin and pushing spool to opposite end. Push YY1 valve to confirm unload capability. If valve works, problem is electrical.</p> <p>Slipper seals worn out or damaged. Replace.</p> <p>Check valve in slide valve piston sticking. Remove and clean check valve.</p>
SLIDE VALVE WILL UNLOAD BUT WILL NOT LOAD	<p>YY2 solenoid coil burned out. Replace coil.</p> <p>Dirt inside solenoid valve preventing valve from operating both ways. Clean valve.</p> <p>Solenoid may be mechanically actuated by inserting a piece of 3/16" rod against armature pin and pushing spool to opposite end. If valve works, the problem is electrical.</p>
SLIDE STOP WILL NOT FUNCTION IN EITHER DIRECTION	<p>Solenoid coil burned out. Replace coils.</p> <p>Solenoid valve sticking. Replace valve.</p>
SLIDE VALVE and/or SLIDE STOP WILL NOT MOVE	<p>Slipper seals worn out or damaged.</p> <p>Unloader spindle or slide valve jammed.</p> <p>Slide stop indicator rod jammed.</p>

**COMPRESSOR PORT LOCATIONS - RXF 12 - 19**

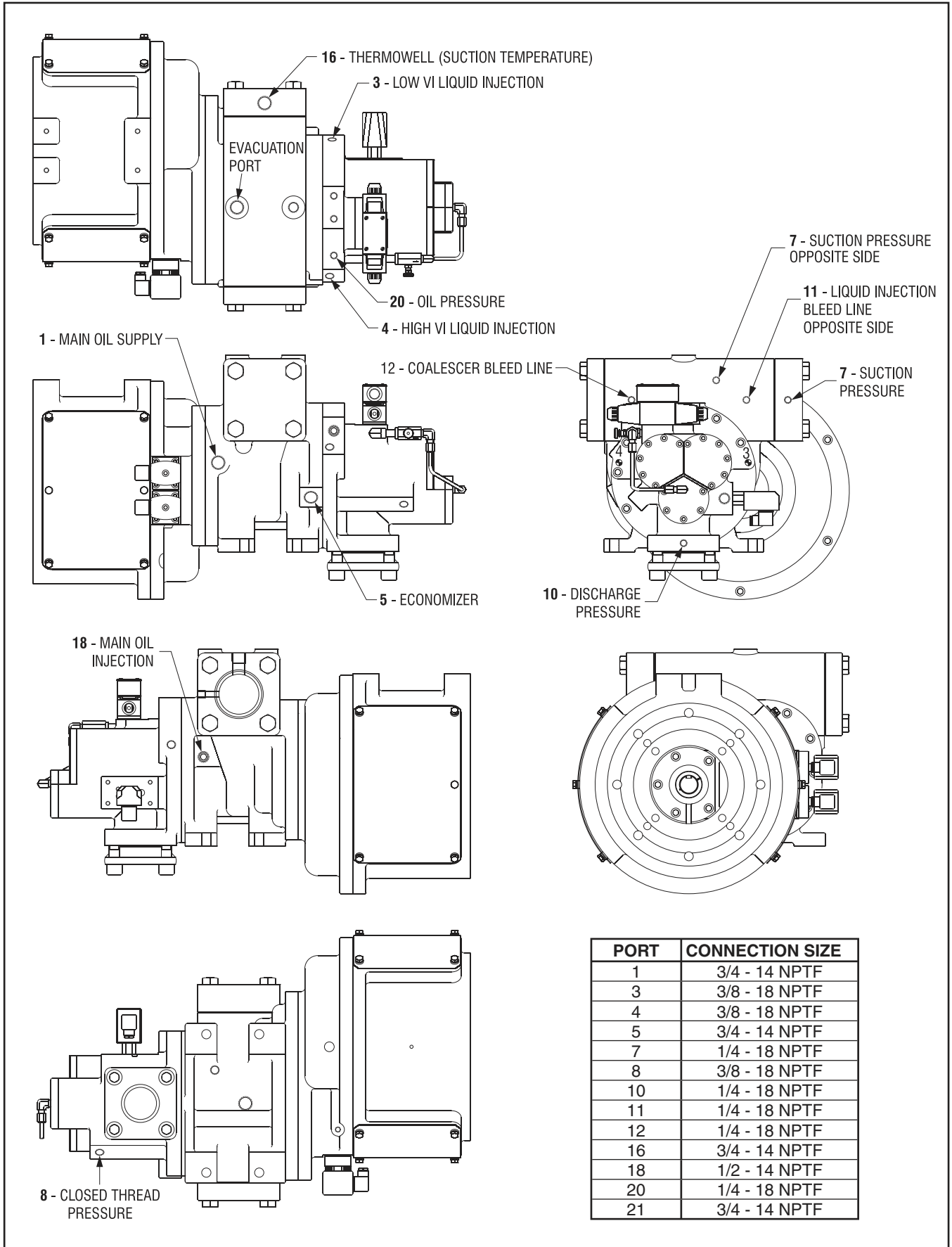

**COMPRESSOR PORT LOCATIONS - RXF 24 - 50**

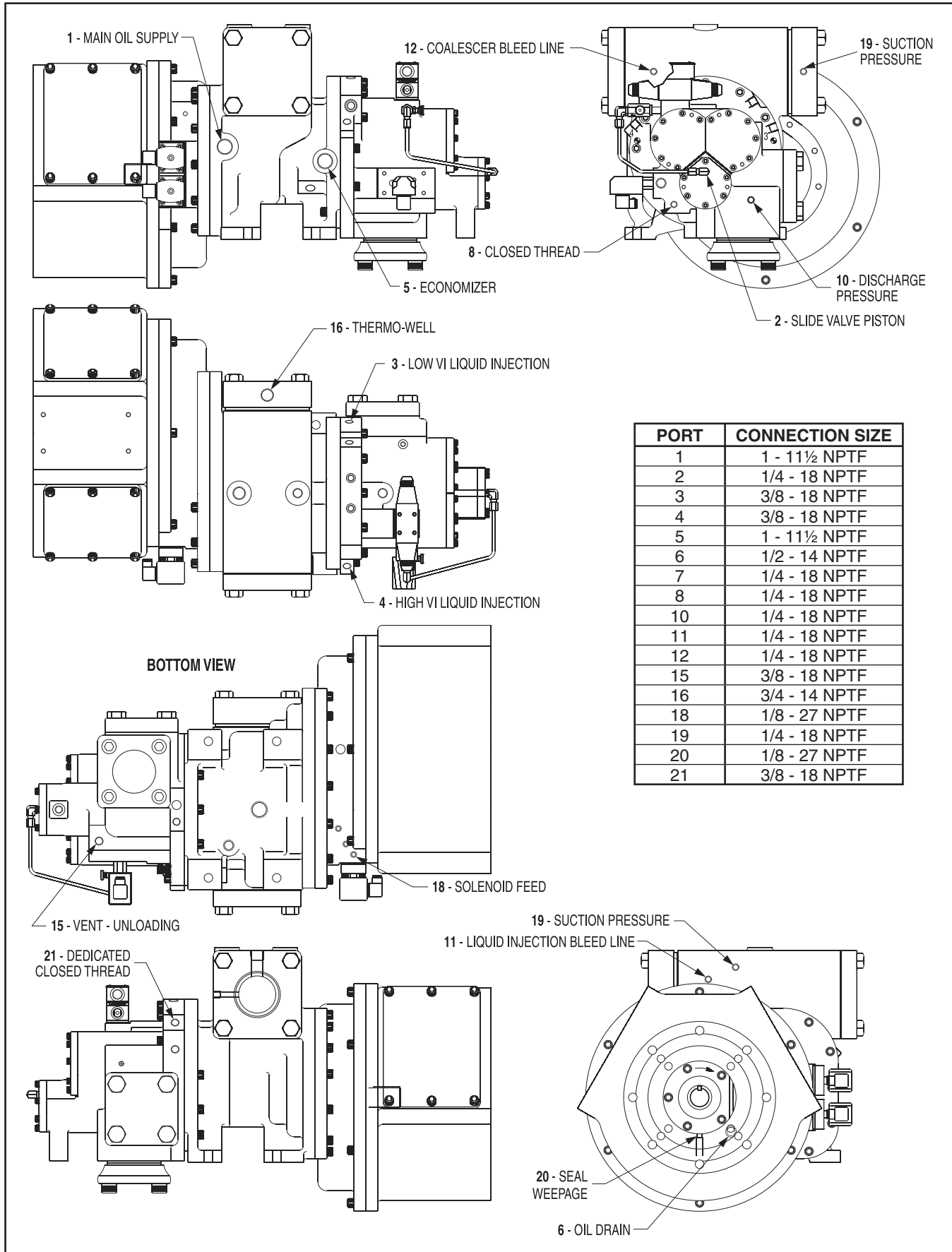

PORT	CONNECTION SIZE
1	1 - 11½ NPTF
2	1/4 - 18 NPTF
3	3/8 - 18 NPTF
4	3/8 - 18 NPTF
5	1 - 11½ NPTF
6	1/2 - 14 NPTF
7	1/4 - 18 NPTF
8	1/4 - 18 NPTF
10	1/4 - 18 NPTF
11	1/4 - 18 NPTF
12	1/4 - 18 NPTF
15	3/8 - 18 NPTF
16	3/4 - 14 NPTF
18	1/8 - 27 NPTF
19	1/4 - 18 NPTF
20	1/8 - 27 NPTF
21	3/8 - 18 NPTF

**COMPRESSOR PORT LOCATIONS - RFX 58 - 101**

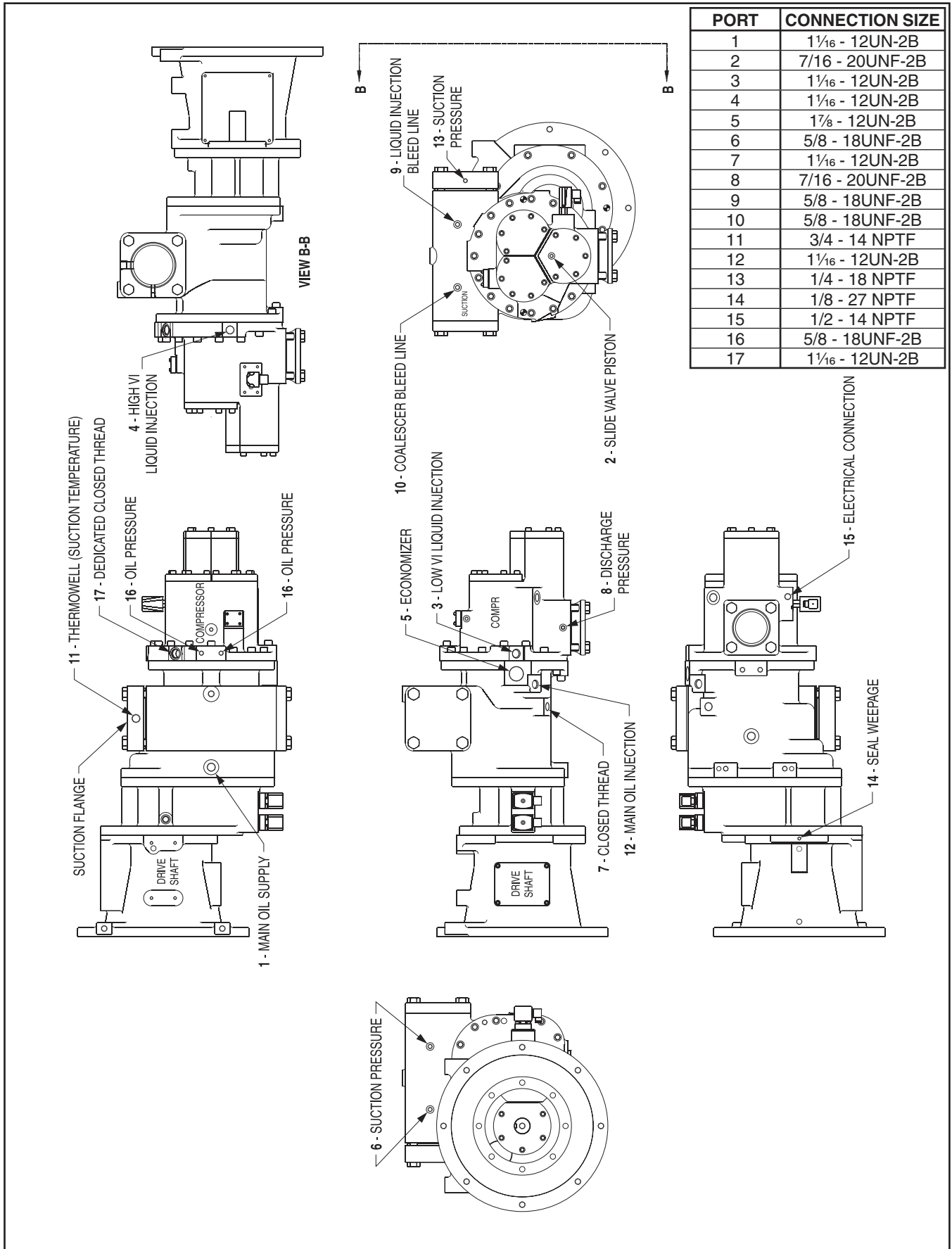

**P & I DIAGRAM, LIQUID INJECTION – SINGLE PORT**

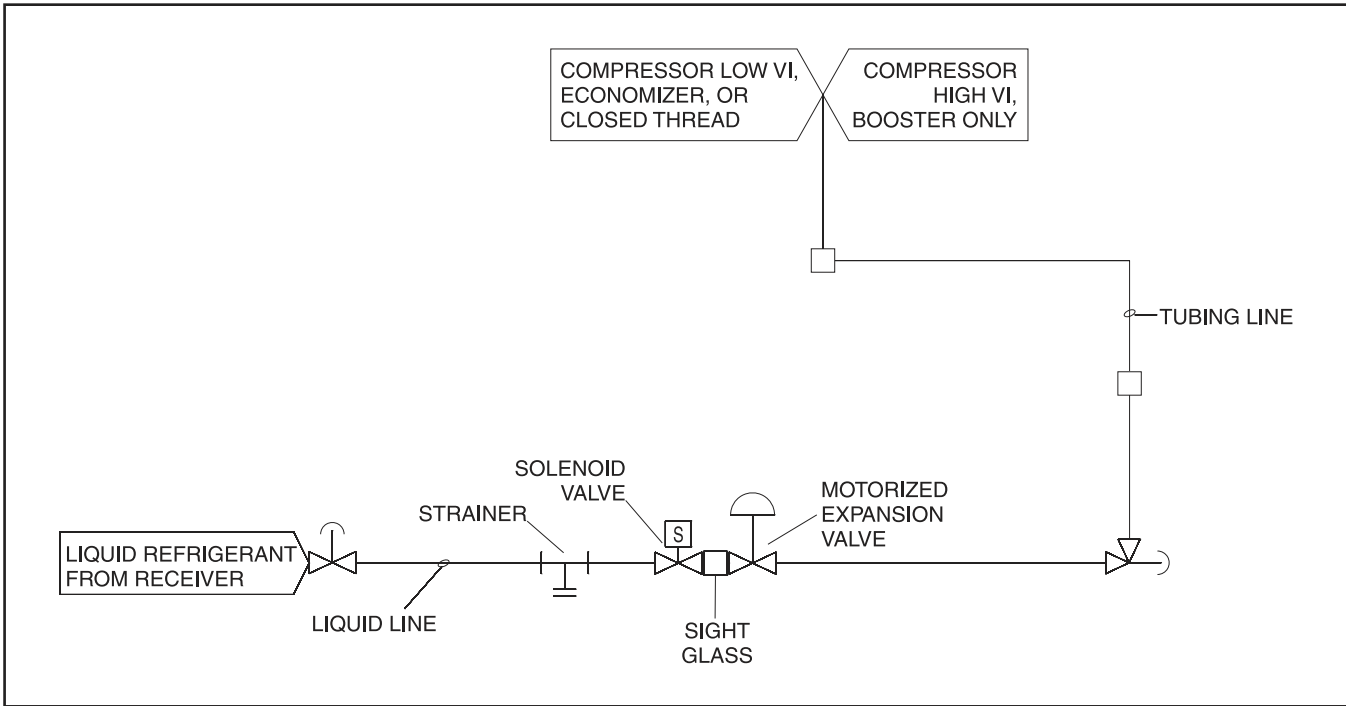

**P & I DIAGRAM, LIQUID INJECTION – DUAL PORT**

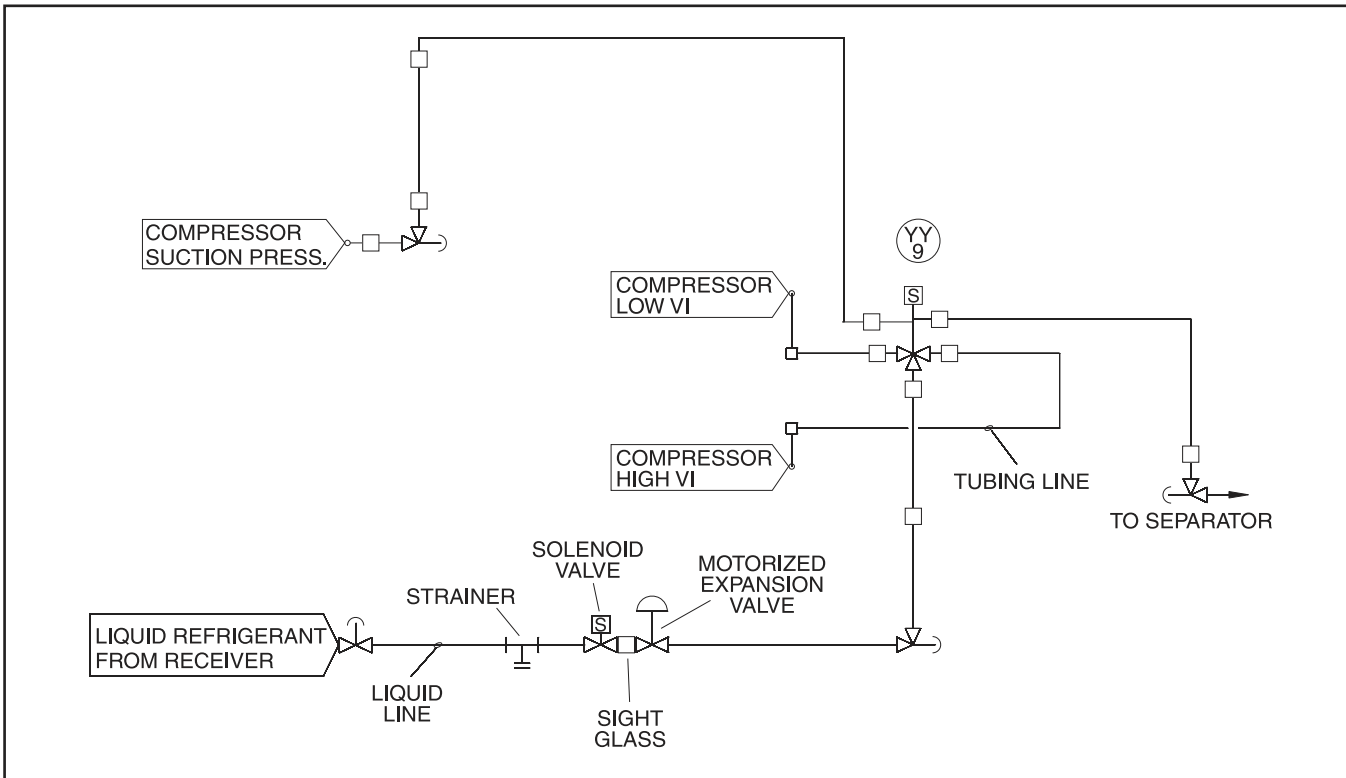

**RXF COOLING OPTIONS (See P & I Diagrams)**

**PLATE and SHELL THERMOSYPHON or WATER-COOLED OIL COOLER**

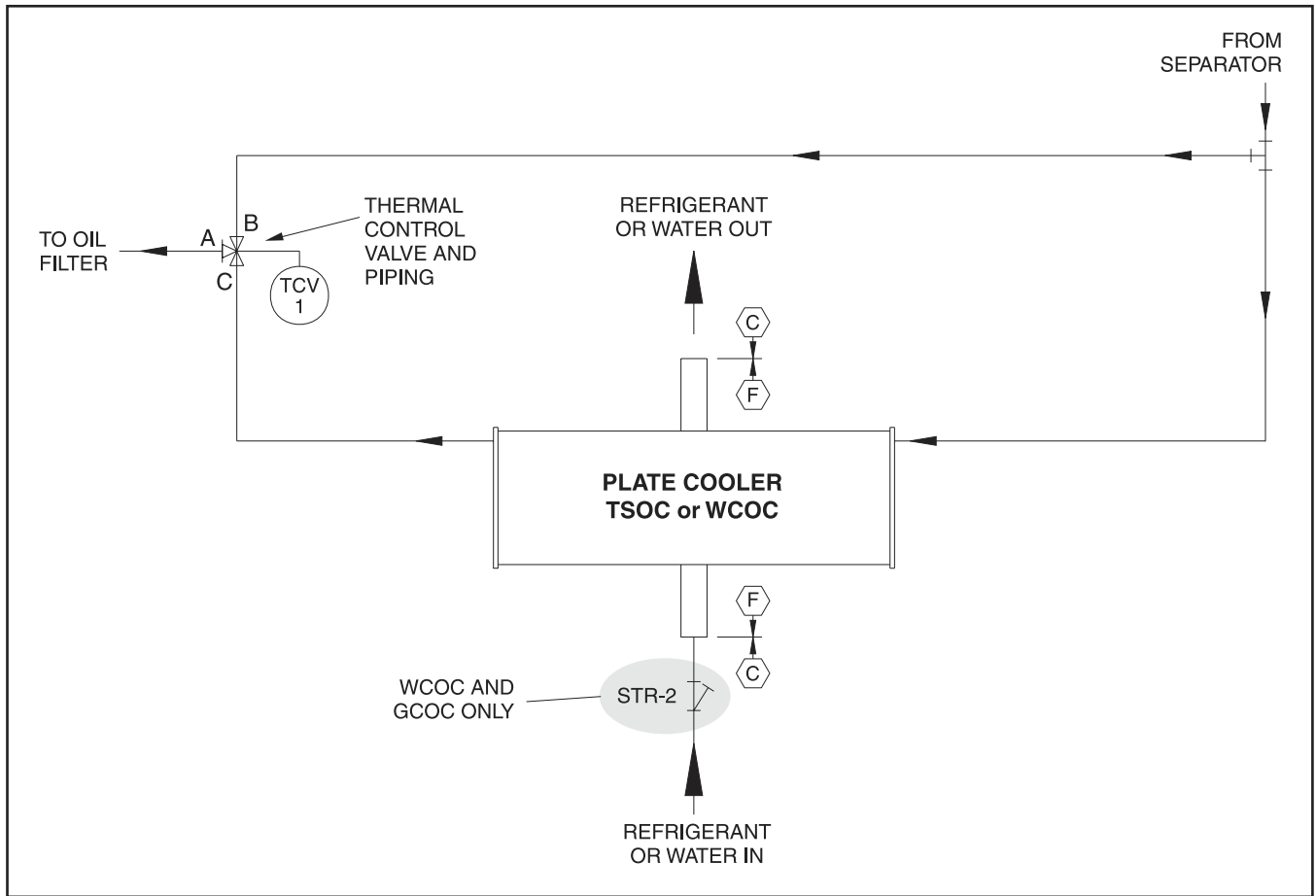

**FLAT PLATE OIL COOLER**

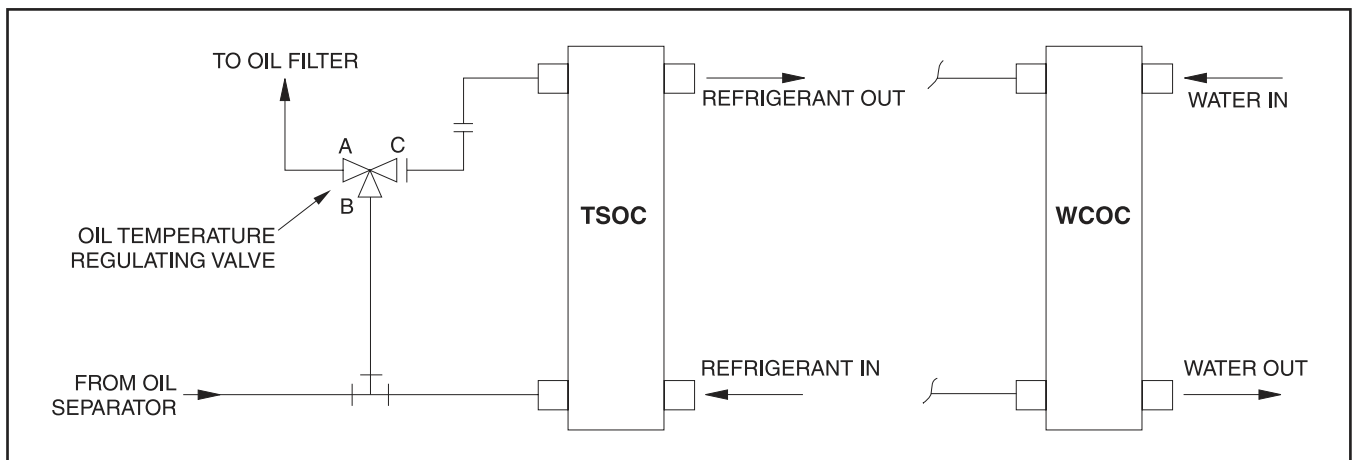

RXF MODELS 12 through 50 without OIL PUMP (See OIL COOLING ADDITIONS)

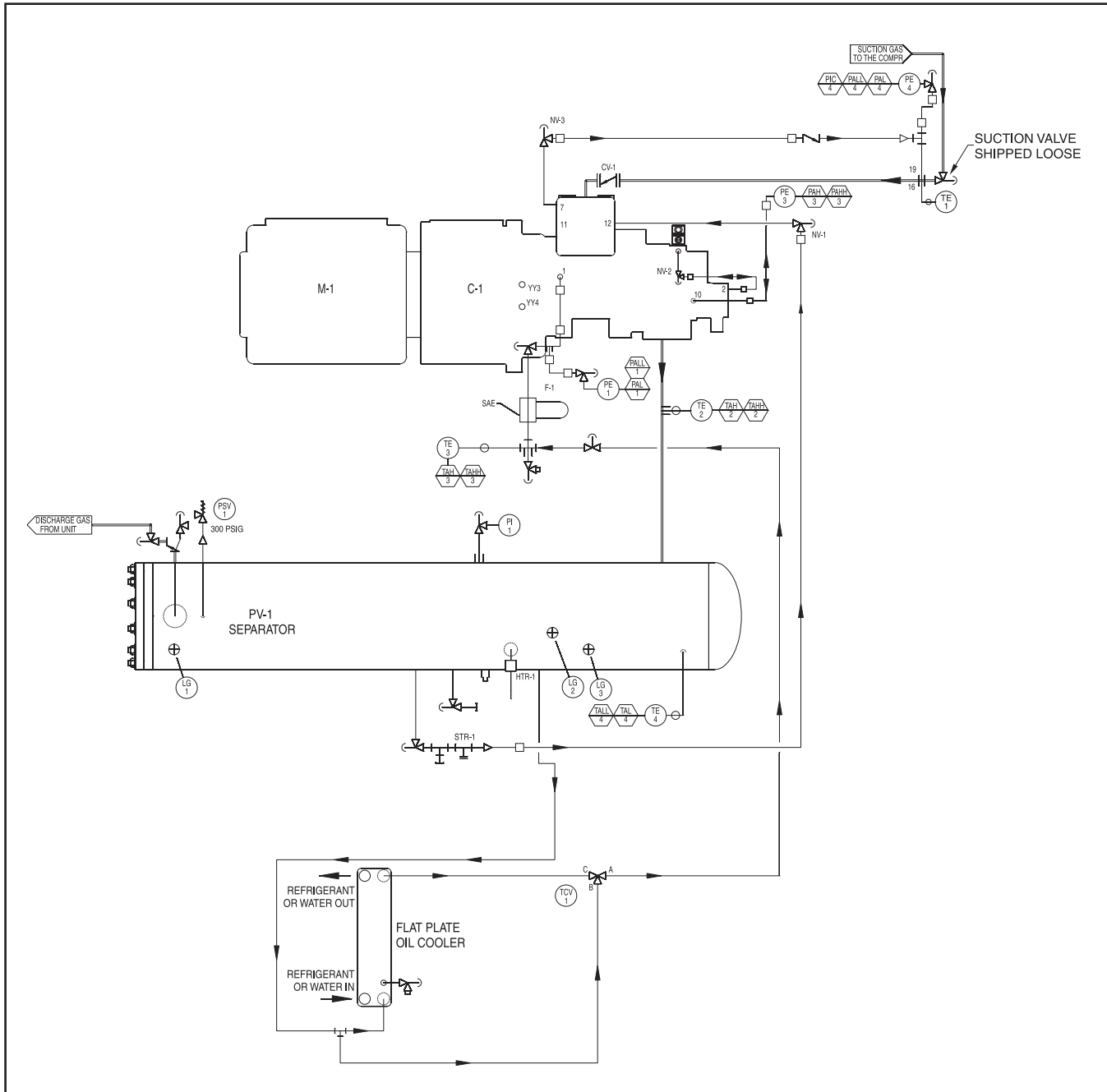

LEGEND*					
AS	AIR SUPPLY	P	PUMP	TAH	HIGH TEMPERATURE ALARM
C	COMPRESSOR	PAH	HIGH PRESSURE ALARM	TAHH	HIGH TEMP. SHUTDOWN
CV	CHECK VALVE	PAHH	HIGH PRESSURE SHUTDOWN	TAL	LOW TEMPERATURE ALARM
DP	DISCHARGE PRESSURE	PAL	LOW PRESSURE ALARM	TALL	LOW TEMPERATURE SHUTDOWN
F	FILTER OR FILTER DRIER	PALL	LOW PRESSURE SHUTDOWN	TCV	TEMPERATURE CONTROL VALVE
FG	FLOW GLASS	PCV	PRESSURE CONTROL VALVE	TE	TEMPERATURE ELEMENT
HTR	HEATER	PDSLL	LOW DIFFERENTIAL PRESS. SHUTDOWN	TI	TEMPERATURE INDICATOR
HV	HAND ACTUATED VALVE	PE	PRESSURE ELEMENT	TS	TEMPERATURE SWITCH
LG	SIGHT OR LEVEL GLASS	PI	PRESSURE INDICATOR	TSH	TEMP. SWITCH HIGH ALARM
LSL	OIL LEVEL SWITCH LOW	PIC/TIC	PRESS./TEMP. INDICATING CONTROLLER	TSL	LIQUID INJECTION SHUTOFF
LSLL	LOW OIL LEVEL SHUTDOWN	PM	PUMP MOTOR	TW	THERMOWELL
M	MOTOR	PS	AUTO CYCLE/PRESSURE SWITCH	VI	VI CONTROL
1MC	MOTOR CONTROL CENTER	PSV	PRESSURE SAFETY VALVE	WS	WATER SUPPLY
2MC	MOTOR CONTROL CENTER	SP	SUCTION PRESSURE	YY	SOLENOID VALVE/EVENT VALVE
OP	OIL PRESSURE	STR	STRAINER		

\* See additional Legend items on opposite page.

RXF MODELS 12 through 50 with OIL PUMP (See OIL COOLING ADDITIONS)

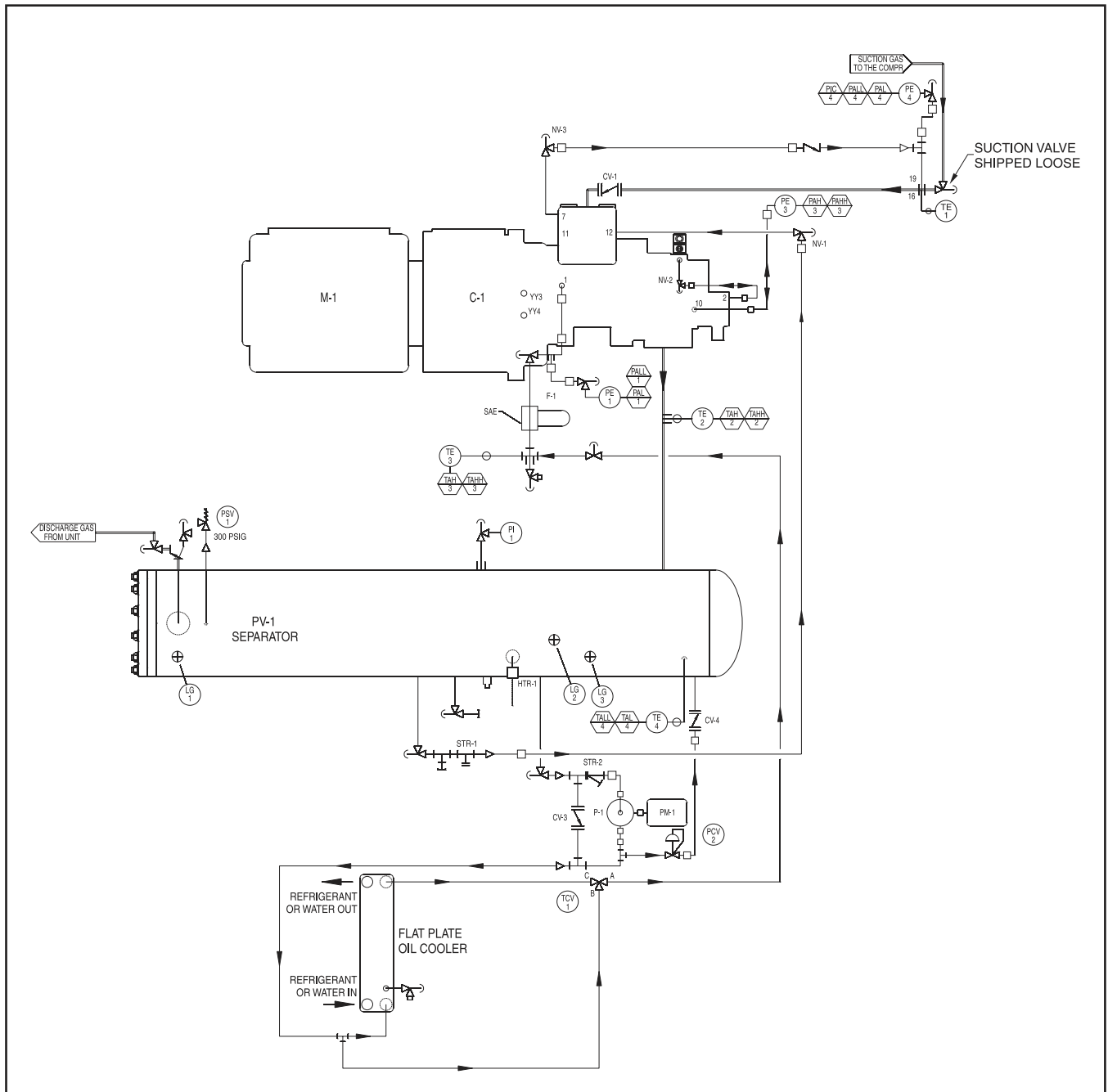

LEGEND (Cont.)

CONNECTIONS		LEGEND (Cont.)		NOTES:
1	MAIN OIL SUPPLY	15	VENT - UNLOADING	
2	SLIDE VALVE PISTON	16	THERMOWELL	
3	LOW VI LIQUID INJECTION	19	SUCTION PRESSURE	
4	HIGH VI LIQUID INJECTION			
5	ECONOMIZER			
6	OIL DRAIN			
7	SUCTION PRESSURE			
8	CLOSED THREAD			
10	DISCHARGE PRESSURE			
11	LIQ. INJ. BLEED LINE			
12	COALESCER BLEED LINE			

RXF MODELS 58, 68, 85, & 101 without OIL PUMP (See OIL COOLING ADDITIONS)

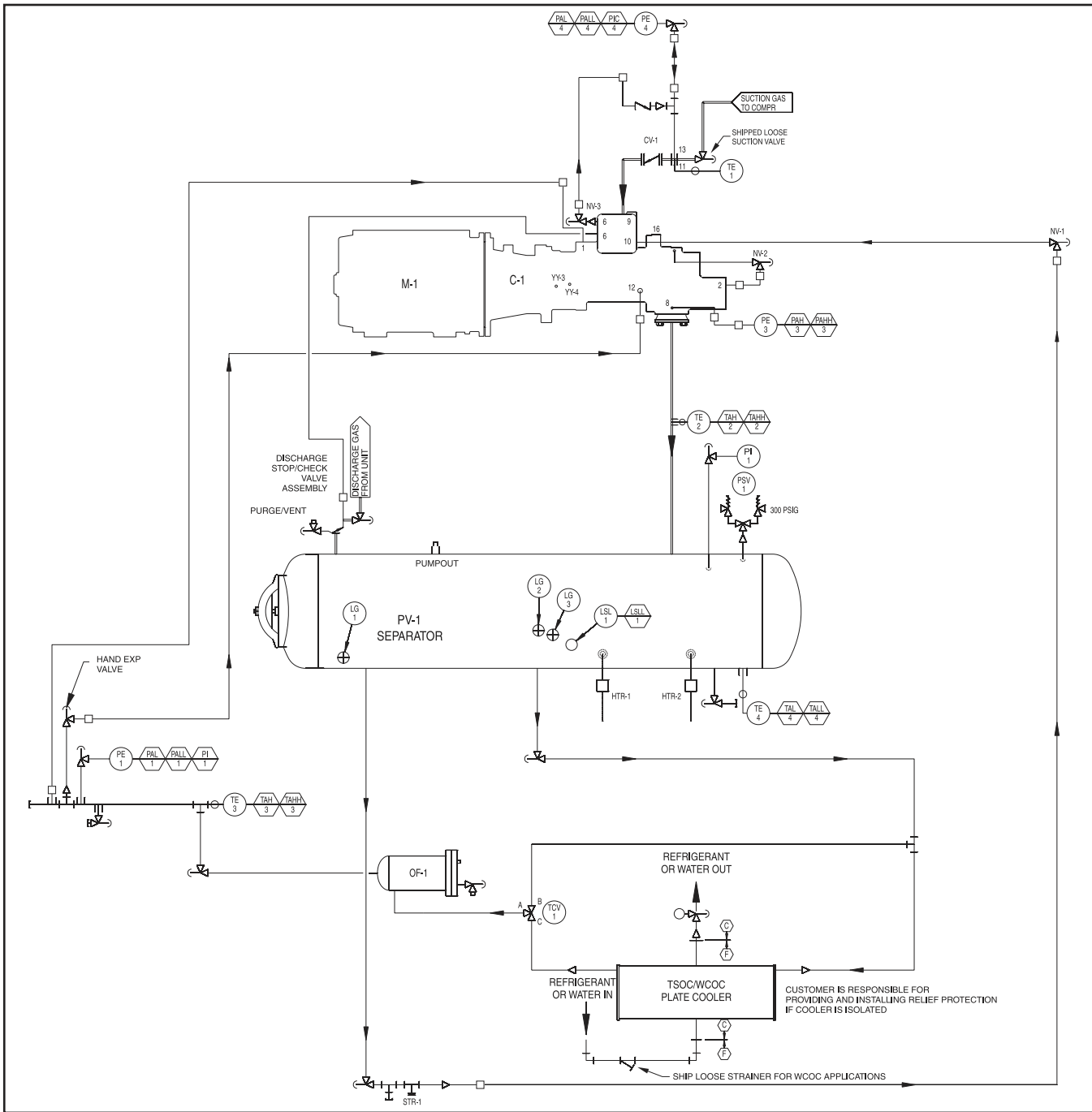

LEGEND\*

AS	AIR SUPPLY	P	PUMP	TAH	HIGH TEMPERATURE ALARM
C	COMPRESSOR	PAH	HIGH PRESSURE ALARM	TAHH	HIGH TEMP. SHUTDOWN
CV	CHECK VALVE	PAHH	HIGH PRESSURE SHUTDOWN	TAL	LOW TEMPERATURE ALARM
DP	DISCHARGE PRESSURE	PAL	LOW PRESSURE ALARM	TALL	LOW TEMPERATURE SHUTDOWN
F	FILTER OR FILTER DRIER	PALL	LOW PRESSURE SHUTDOWN	TCV	TEMPERATURE CONTROL VALVE
FG	FLOW GLASS	PCV	PRESSURE CONTROL VALVE	TE	TEMPERATURE ELEMENT
HTR	HEATER	PDSLL	LOW DIFFERENTIAL PRESS. SHUTDOWN	TI	TEMPERATURE INDICATOR
HV	HAND ACTUATED VALVE	PE	PRESSURE ELEMENT	TS	TEMPERATURE SWITCH
LG	SIGHT OR LEVEL GLASS	PI	PRESSURE INDICATOR	TSH	TEMP. SWITCH HIGH ALARM
LSL	OIL LEVEL SWITCH LOW	PI/TIC	PRESS./TEMP. INDICATING CONTROLLER	TSL	LIQUID INJECTION SHUTOFF
LSLL	LOW OIL LEVEL SHUTDOWN	PM	PUMP MOTOR	TW	THERMOWELL
M	MOTOR	PS	AUTO CYCLE/PRESSURE SWITCH	VI	VI CONTROL
1MC	MOTOR CONTROL CENTER	PSV	PRESSURE SAFETY VALVE	WS	WATER SUPPLY
2MC	MOTOR CONTROL CENTER	SP	SUCTION PRESSURE	YY	SOLENOID VALVE/EVENT VALVE
OP	OIL PRESSURE	STR	STRAINER		

\* See additional Legend items on opposite page.

**RXF MODELS 58, 68, 85, & 101 with OIL PUMP (See OIL COOLING ADDITIONS)**

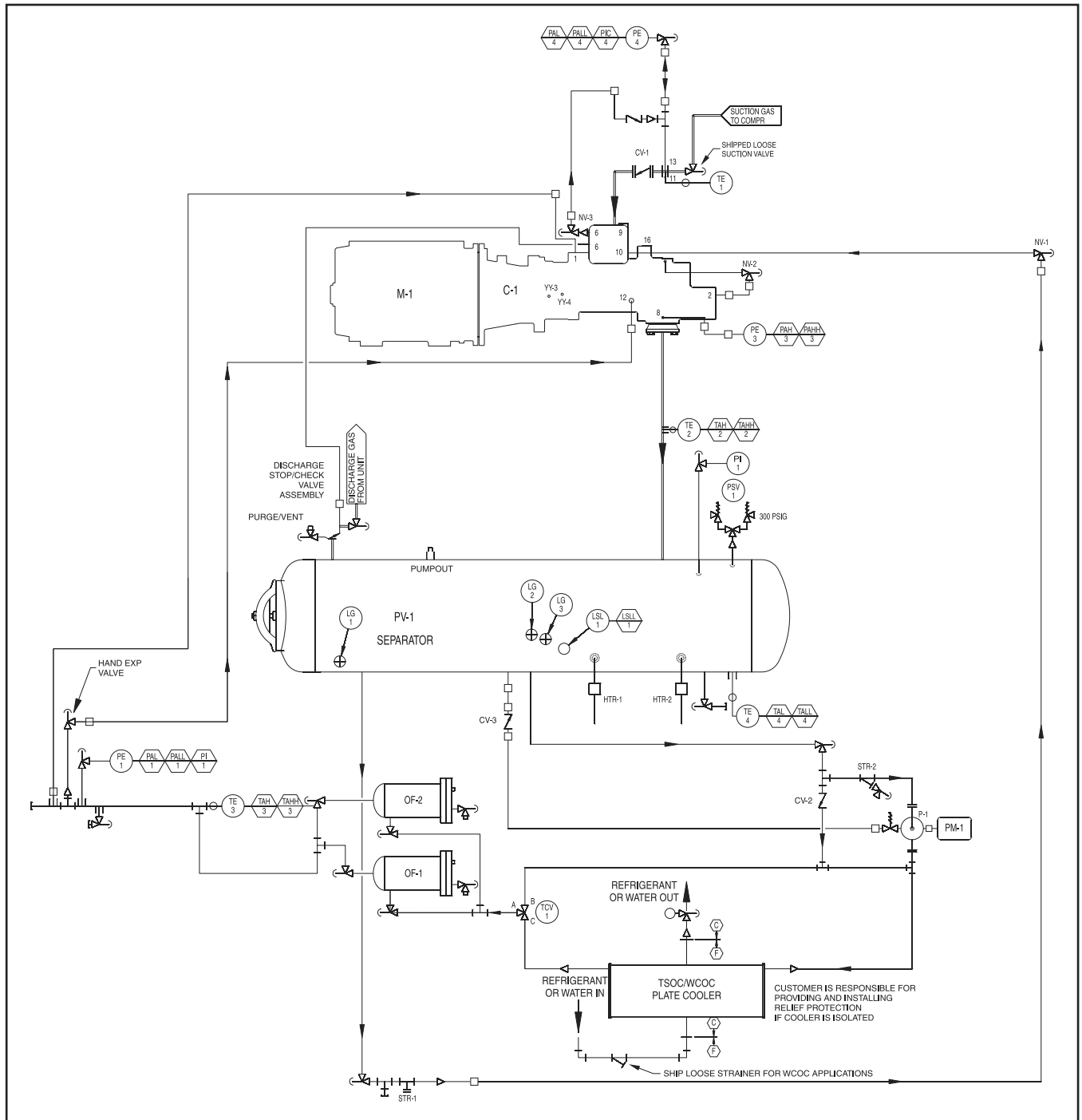

**LEGEND (Cont.)**

**CONNECTIONS**

- 1 MAIN OIL SUPPLY
- 2 SLIDE VALVE PISTON
- 3 LOW VI LIQUID INJECTION
- 4 HIGH VI LIQUID INJECTION
- 5 ECONOMIZER
- 6 SUCTION PRESSURE
- 7 CLOSED THREAD
- 8 DISCHARGE PRESSURE
- 9 LIQ. INJ. BLEED LINE
- 10 COALESCER BLEED LINE
- 11 THERMOWELL (SUCT. TEMP.)

- 12 MAIN OIL INJECTION
- 13 SUCTION PRESSURE
- 14 SEAL WEEPAGE
- 15 ELECTRICAL CONNECTION
- 16 OIL PRESSURE

**NOTES:**

1. PRESSURE TRANSDUCERS INDICATE:  
PE-1 OIL PRESSURE  
PE-3 DISCHARGE PRESSURE  
PE-4 SUCTION PRESSURE
2. TEMPERATURE PROBES INDICATE:  
TE-1 SUCTION GAS TEMPERATURE  
TE-2 DISCHARGE GAS TEMPERATURE  
TE-3 LUBE OIL TEMPERATURE  
TE-4 SEPARATOR OIL TEMPERATURE
3. TERMINATIONS "A" THROUGH "C" REFER TO CONNECTION POINTS FOR VARIOUS OPTIONS.

**WIRING HARNESS - AC to Heaters and Valves (External)**

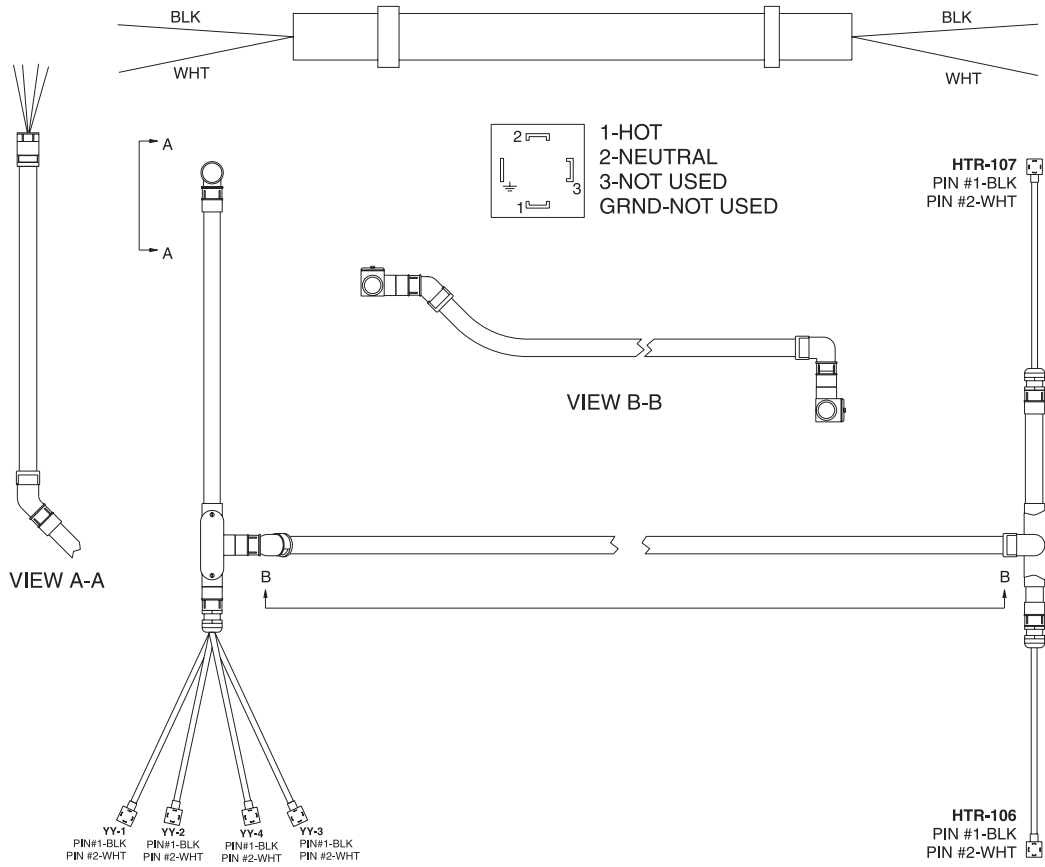

**WIRING HARNESS - External for Analog Devices**

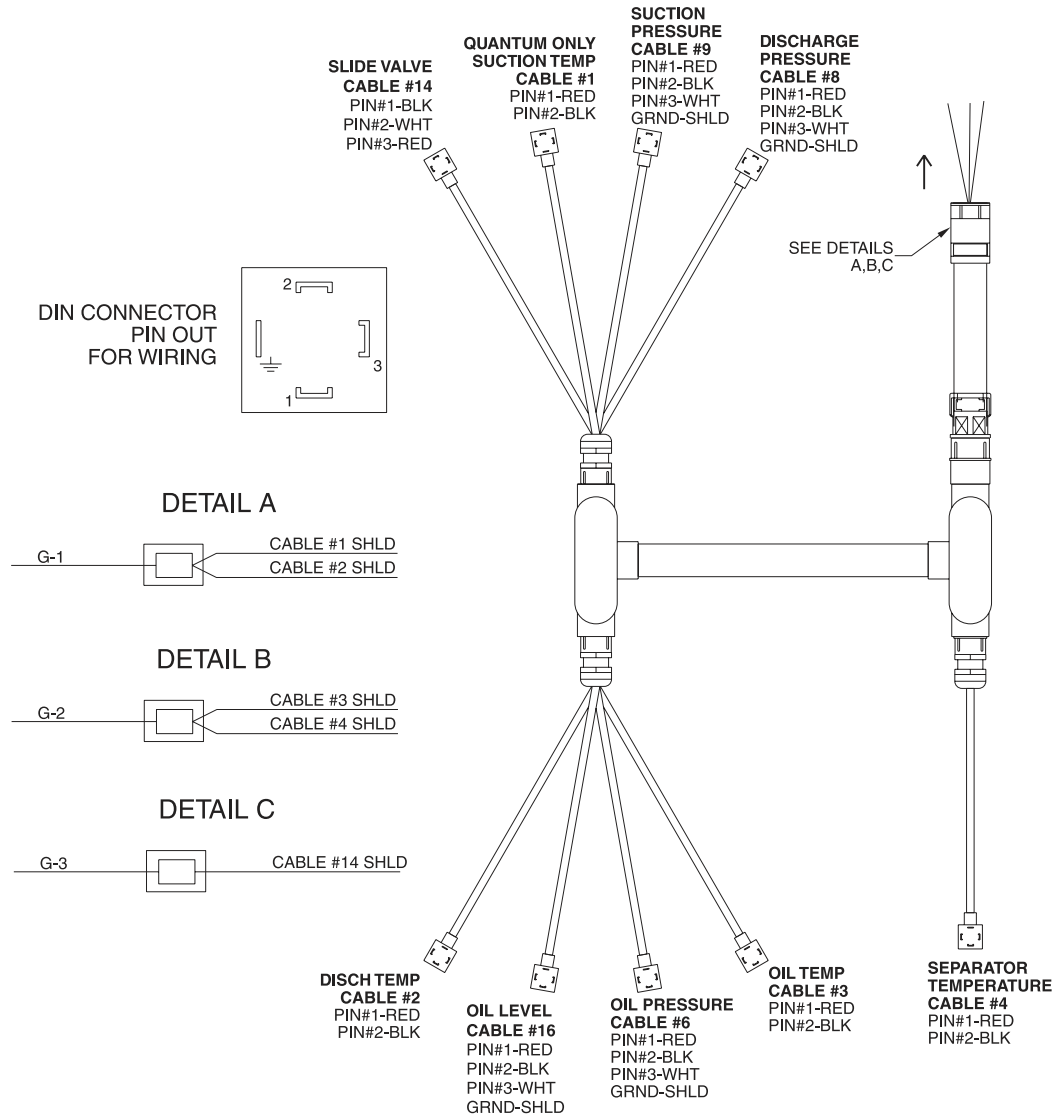

**WIRING HARNESS - AC Conduit - Quantum to DBS Panel**

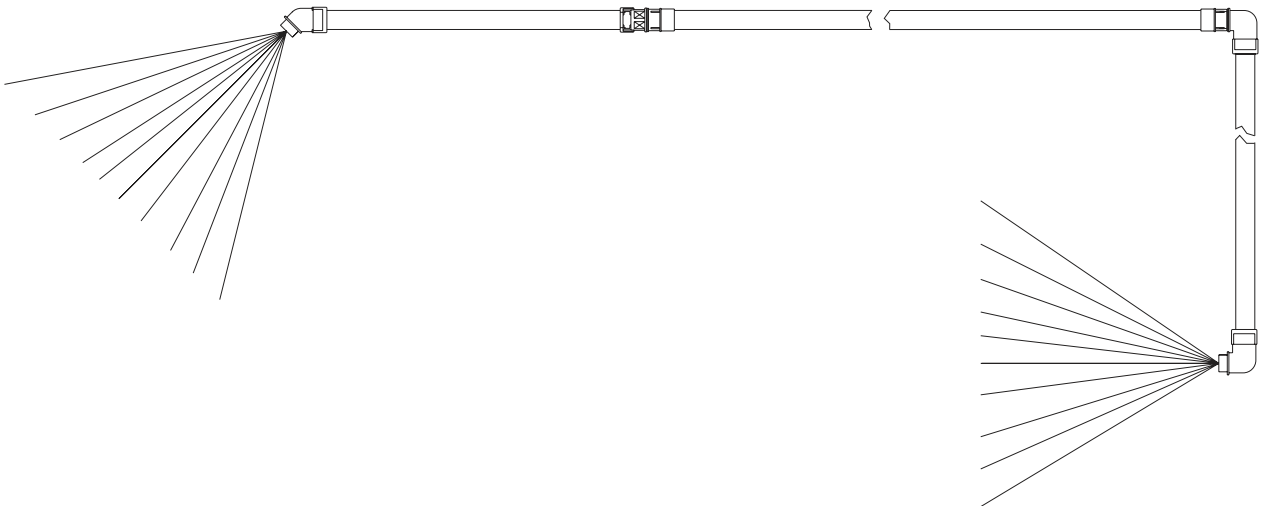

## PROPER INSTALLATION OF ELECTRONIC EQUIPMENT IN AN INDUSTRIAL ENVIRONMENT

In today's refrigeration plants, electronic controls have found their way into almost every aspect of refrigeration control. Electronic controls have brought to the industry more precise control, improved energy savings and operator conveniences. Electronic control devices have revolutionized the way refrigeration plants operate today.

The earlier relay systems were virtually immune to radio frequency interference (RFI), electromagnetic interference (EMI), and ground loop currents. Therefore installation and wiring were of little consequence and the wiring job consisted of hooking up the point-to-point wiring and sizing the wire properly. In an electronic system, improper installation will cause problems that outweigh the benefits of electronic control. Electronic equipment is susceptible to RFI, EMI, and ground loop currents which can cause equipment shutdowns, processor memory and program loss, erratic behavior, and false readings. Manufacturers of industrial electronic equipment take into consideration the effects of RFI, EMI, and ground loop currents and incorporate protection of the electronics in their designs. These manufacturers require that certain installation precautions be taken to protect the electronics from these effects. All electronic equipment must be viewed as sensitive instrumentation and therefore requires careful attention to installation procedures. These procedures are well known to instrument engineers, but are usually not followed by general electricians.

There are a few basics, that if followed, will result in a trouble-free installation. The National Electric Code (NEC) is a guideline for safe wiring practices, but it does not deal with procedures used for electronic control installation. **Use the following procedures for electronic equipment installation.** These procedures do not override any rules by the NEC, but are to be used in conjunction with the NEC code.

### WIRE SIZING

**Size supply wires one size larger than required for amperage draw to reduce instantaneous voltage dips caused by large loads such as heaters and contactors and solenoids.** These sudden dips in voltage can cause the processor, whether it be a microprocessor, a computer, or a PLC to malfunction momentarily or cause a complete reset of the control system. If the wire is loaded to its maximum capacity, the voltage dips are much larger, and the potential of a malfunction is very high. If the wire is sized one size larger than required, the voltage dips are smaller than in a fully loaded supply wire, and the potential for malfunction is much lower. The NEC code book calls for specific wire sizes to be used based on current draw. An example of this would be to use #14 gauge wire for circuits up to 15 amp or #12 gauge wire for circuits of up to 20 amp. Therefore, when connecting the power feed circuit to an electronic industrial control, use #12 gauge wire for a maximum current draw of 15 amp and #10 wire for a maximum current draw of 20 amp. Use this rule of thumb to minimize voltage dips at the electronic control.

### VOLTAGE SOURCE

Selecting the voltage source is extremely important for proper operation of electronic equipment in an industrial environment. Standard procedure for electronic instrumentation is to provide a "clean" separate source voltage in order to prevent EMI, from other equipment in the plant, from interfering with the operation of the electronic equipment. Connecting electronic equipment to a breaker panel (also known as lighting panels and fuse panels) subjects the electronic equipment to noise generated by other devices connected to the breaker panel. This noise is known as electromagnetic interference (EMI). EMI flows on the wires that are common to a circuit. EMI cannot travel easily through transformers and therefore can be isolated from selected circuits. **Use a control transformer to isolate the electronic control panel from other equipment in the plant that generate EMI. (Figure 28)**

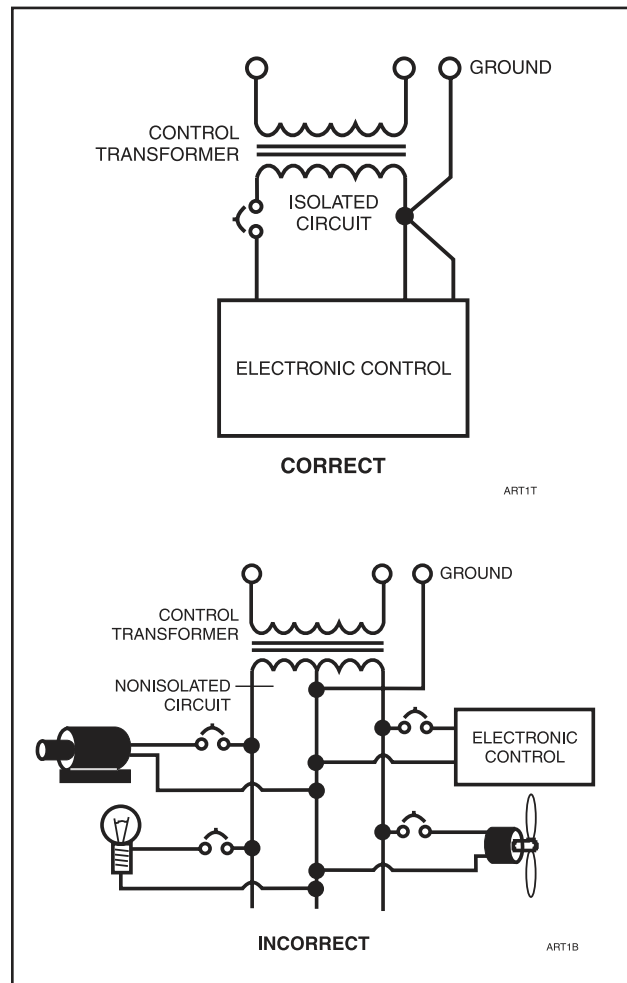

Figure 28

**GROUNDING**

Grounding is the most important factor for successful operation and is also the most overlooked. The NEC states that control equipment may be grounded by using the rigid conduit as a conductor. This worked for the earlier relay systems, but it is not acceptable for electronic control equipment. Conduit is made of steel and is a poor conductor relative to a copper wire. Electronic equipment reacts to very small currents and must have a good ground in order to operate properly; therefore, **copper grounds are required for proper operation. Note: aluminum may be used for the large three-phase ground wire.**

The ground wire must be sized the same size as the supply wires or one size smaller as a minimum. The three phase power brought into the plant must also have a ground wire, making a total of four wires. In many installations that are having electronic control problems, this essential wire is usually missing. A good ground circuit must be continuous from the plant source transformer to the electronic control panel for proper operation. See Figure 29. Driving a ground stake at the electronic control will cause additional problems since other equipment in the plant on the same circuits will ground themselves to the ground stake causing large ground flow at the electronic equipment.

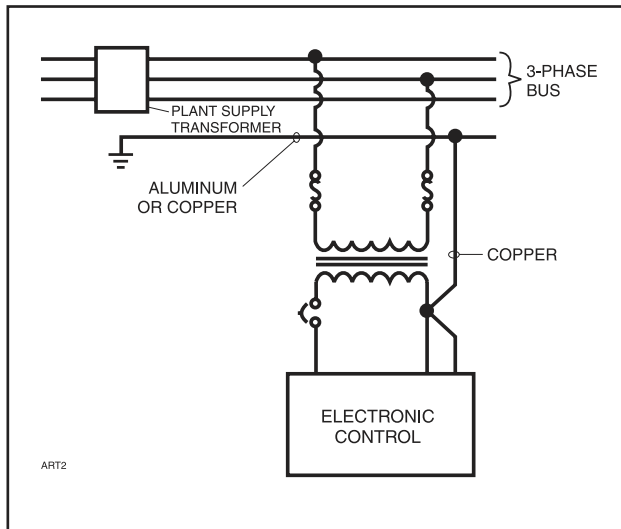

Figure 29

**WIRING PRACTICES**

**Do not mix wires of different voltages in conduit.** An example of this would be the installation of a screw compressor package. The motor voltage is 480 volts and the panel control power is 120 volts. **The 480 volt circuit must be run from the motor starter to the motor in its own conduit. The 120 volt circuit must be run from the motor starter control transformer to the control panel in its own separate conduit.** If the two circuits are run in the same conduit, transients on the 480 volt circuit will be inducted into the 120 volt circuit causing functional problems with the electronic control. Dividers must be used in wire way systems (conduit trays) to separate unlike voltages. The same rule applies for 120 volt wires and 220 volt wires. **Also, never run low voltage wires in the same conduit with 120 volt wires. (Figure 30)**

**Never run any wires through an electronic control panel that do not relate to the function of the panel. Electronic control panels should never be used as a junction box.** These wires may be carrying large transients that will interfere with the operation of the control. An extreme example of this would be to run the 480 volts from a motor starter through the control panel to the motor.

When running conduit to an electronic control panel, take notice of the access holes (knockouts) provided by the manufacturer. These holes are strategically placed so that the field wiring does not interfere with the electronics in the panel. **Never allow field wiring to come in close proximity with the controller boards since this will almost always cause problems.**

**Do not drill a control panel to locate conduit connections.** You are probably not entering the panel where the manufacturer would like you to since most manufacturers recommend or provide pre-punched conduit connections. Drilling can cause metal chips to land in the electronics and create a short circuit. **If you must drill the panel, take the following precautions:** First cover the electronics with plastic and tape it to the board with masking or electrical tape. Second, place masking tape or duct tape on the inside of the panel where you are going to drill. The tape will catch most of the chips. Then clean all of the remaining chips from the panel before removing the protective plastic. It would be a good idea to call the manufacturer before drilling the panel to be sure you are entering the panel at the right place.

When routing conduit to the top of an electronic control panel, condensation must be taken into consideration. Water can condense in the conduit and run into the panel causing catastrophic failure. **Route the conduit to the sides or bottom of the panel and use a conduit drain.** If the conduit must be routed to the top of the panel, use a sealable conduit fitting which is poured with a sealer after the wires have been pulled, terminated and the control functions have been checked. **A conduit entering the top of the enclosure must have an "O" ring-type fitting between the conduit and the enclosure,** so that if water gets on top of the enclosure, it cannot run in between the conduit and the enclosure. This is extremely important in outdoor applications.

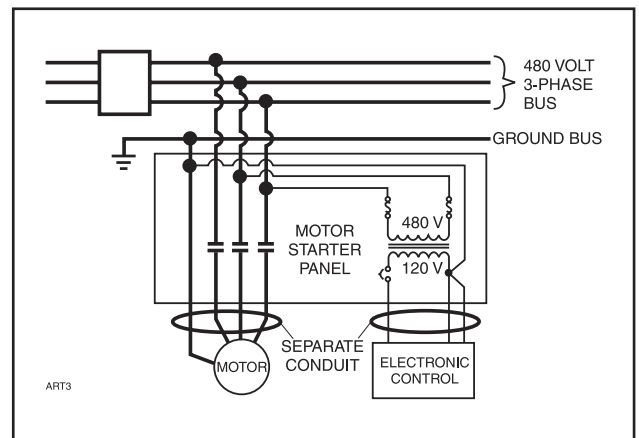

Figure 30

**Never add relays, starters, timers, transformers, etc. inside an electronic control panel without first contacting the manufacturer.** Contact arcing and EMI emitted from these devices can interfere with the electronics. Relays and timers are routinely added to electronic control panels by the manufacturer, but the manufacturer knows the acceptable device types and proper placement in the panel that will keep interference to a minimum. If you need to add these devices contact the manufacturer for the proper device types and placement.

**Never run refrigerant tubing inside an electronic control panel.** If the refrigerant is ammonia, a leak will totally destroy the electronics.

**If the electronic control panel has a starter built into the same panel, be sure to run the higher voltage wires where indicated by the manufacturer.** EMI from the wires can interfere with the electronics if run too close to the circuitry.

**Never daisy-chain or parallel-connect power or ground wires to electronic control panels.** Each electronic control panel must have its own supply wires back to the power source. Multiple electronic control panels on the same power wires create current surges in the supply wires which can cause controller malfunctions. Daisy-chaining ground wires allows ground loop currents to flow between electronic control panels which also causes malfunctions. See Figure 31.

It is very important to read the installation instructions thoroughly before beginning the project. Make sure you have drawings and instructions with your equipment. If not, call the manufacturer and have them send you the proper instructions. Every manufacturer of electronic equipment should have a knowledgeable staff, willing to answer your questions or fax additional information. Following correct wiring procedures will ensure proper installation of your electronic equipment.

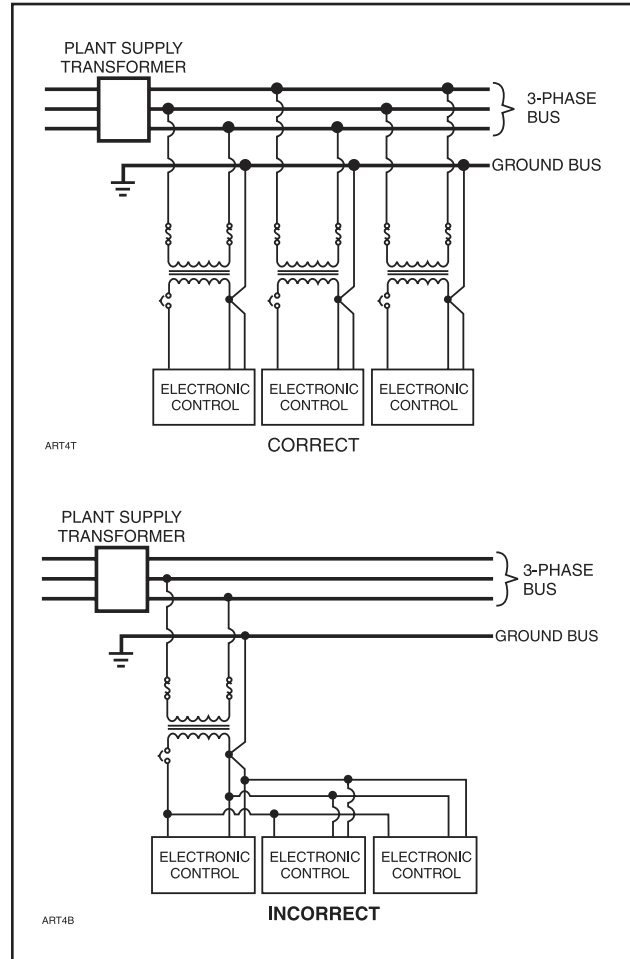

Figure 31





### COMPRESSOR PRESTART CHECKLIST

The following items **MUST** be checked and completed by the installer prior to the arrival of the Frick Field Service Supervisor. Details on the checklist can be found in the IOM. Certain items on this checklist will be reverified by the Frick Field Service Supervisor prior to the actual start-up.

#### Mechanical Checks

- Confirm that motor disconnect is open
- Isolate suction pressure transducer
- Pressure test and leak check unit
- Evacuate unit
- Remove compressor drive coupling guard
- Remove coupling center and **do not reinstall**
- Check for correct position of all hand, stop, and check valves prior to charging unit with oil or refrigerant
- Charge unit with correct type and quantity of oil
- Lubricate motor bearings (if applicable)
- Check oil pump alignment (if applicable)
- Check for correct economizer piping (if applicable)
- Check separate source of liquid refrigerant supply (if applicable, liquid injection oil cooling)
- Check water supply for water-cooled oil cooler (if applicable, water cooled oil cooling)
- Check thermosyphon receiver refrigerant level (if applicable, thermosyphon oil cooling)

#### Electrical Checks

- Confirm that main disconnect to motor starter and micro is open
- Confirm that electrical contractor has seen this sheet, all pertinent wiring information, and drawings
- Confirm proper power supply to the starter package
- Confirm proper motor protection (breaker sizing)
- Confirm that all wiring used is stranded copper and is 14 AWG or larger (sized properly)
- Confirm all 120 volt control wiring is run in a separate conduit from all high voltage wiring
- Confirm all 120 volt control wiring is run in a separate conduit from oil pump and compressor motor wiring
- Confirm no high voltage wiring enters the micro panel at any point
- Check current transformer for correct sizing and installation
- Check all point-to-point wiring between the micro and motor starter
- Confirm all interconnections between micro, motor starter, and the system are made and are correct

#### After the above items have been checked and verified:

- Close the main disconnect from the main power supply to the motor starter
- Close the motor starter disconnect to energize the micro
- Manually energize oil pump and check oil pump motor rotation
- Manually energize compressor drive motor and check motor rotation
- Leave micro energized to ensure oil heaters are on and oil temperature is correct for start-up

**Summary: The Frick Field Service Supervisor should arrive to find the above items completed. He should find an uncoupled compressor drive unit (to verify motor rotation and alignment) and energized oil heaters with the oil at the proper standby temperatures. Full compliance with the above items will contribute to a quick, efficient and smooth start-up.**

#### The Start-up Supervisor will:

1. Verify position of all valves
2. Verify all wiring connections
3. Verify compressor driver rotation
4. Verify oil pump motor rotation
5. Verify the % of FLA on the micro display
6. Verify and finalize alignment
7. Calibrate slide valve and slide stop
8. Calibrate temperature and pressure readings
9. Correct any problem in the package
10. Instruct operation personnel

**NOTE: Customer connections are to be made per the electrical diagram for the motor starter listed under the installation section and per the wiring diagram found in Frick publication S90-020 M (Quantum™LX).**

**Sign this form & fax to 717-762-8624 as confirmation of completion.**

Signed: \_\_\_\_\_  
Print Name: \_\_\_\_\_  
Company: \_\_\_\_\_



### START-UP REPORT

Sold To: \_\_\_\_\_ Contact Name: \_\_\_\_\_ Date: \_\_\_\_\_  
 End User: \_\_\_\_\_ Contact Name: \_\_\_\_\_ Phone: \_\_\_\_\_  
 End User Address: \_\_\_\_\_ Fax No: \_\_\_\_\_  
 City, State, Zip: \_\_\_\_\_ Start-up Rep. \_\_\_\_\_

#### Unit General Information

Unit Model # \_\_\_\_\_ Customer Package Identification # \_\_\_\_\_  
 Compressor Serial # \_\_\_\_\_ Separator National Board # \_\_\_\_\_  
 Unit Serial # \_\_\_\_\_ Oil Cooler National Board # \_\_\_\_\_  
 Refrigerant  R-717  R-22  R-290  Other \_\_\_\_\_  
 Lube Oil Type  2A  3  4  9  Other \_\_\_\_\_ Design Operating Conditions  
 Lube System  None  Prelube  Cycling  Full  Demand \_\_\_\_\_ °Suct./\_\_\_\_\_ °Disch.  
 Oil Cooling  TSOC  WCOC  S-LIOC  D-LIOC  GCOC  
 Oil Filters  Single  Dual Micro Log I.D. \_\_\_\_\_

#### Micro Information

Micro Type  Quantum™LX  Quantum™  
 CPU Serial # \_\_\_\_\_ Rev. \_\_\_\_\_ Ver # \_\_\_\_\_ and Date \_\_\_\_\_  
 Digital I/O Board #1 Serial # \_\_\_\_\_ Rev. \_\_\_\_\_ U8 Digital I/O Ver # \_\_\_\_\_ and Date \_\_\_\_\_  
 Digital I/O Board #2 Serial # \_\_\_\_\_ Rev. \_\_\_\_\_ U8 Digital I/O Ver # \_\_\_\_\_ and Date \_\_\_\_\_  
 Analog Board #1 Serial # \_\_\_\_\_ Rev. \_\_\_\_\_ Analog Ver # \_\_\_\_\_ and Date \_\_\_\_\_  
 Analog Board #2 Serial # \_\_\_\_\_ Rev. \_\_\_\_\_ Analog Ver # \_\_\_\_\_ and Date \_\_\_\_\_

#### Compressor Motor Information

Manufacturer \_\_\_\_\_ Frame Size \_\_\_\_\_ H.P. \_\_\_\_\_ RPM \_\_\_\_\_  
 Serial # \_\_\_\_\_ Service Factor \_\_\_\_\_ Voltage \_\_\_\_\_ Hz \_\_\_\_\_ FLA \_\_\_\_\_  
 Design \_\_\_\_\_ Code \_\_\_\_\_ Bearing Type  Antifriction  Sleeve

#### Compressor Motor Starter Information

Manufacturer \_\_\_\_\_ Serial # \_\_\_\_\_  
 Starter Type  WDCT  ATL  Auto-Trans  Solid State  Digital DBS  Standalone DBS  
 CT Location Checked  CT Phase \_\_\_\_\_ CT Ratio \_\_\_\_\_ Transition Time \_\_\_\_\_ DBS Ver. # \_\_\_\_\_

#### Oil Pump Information

Pump Manufacturer \_\_\_\_\_ Model # \_\_\_\_\_ Serial # \_\_\_\_\_  
 Motor Manufacturer \_\_\_\_\_ H.P. \_\_\_\_\_ RPM \_\_\_\_\_ Serial # \_\_\_\_\_  
 Service Factor \_\_\_\_\_ Voltage \_\_\_\_\_ Hz \_\_\_\_\_ FLA \_\_\_\_\_ Design \_\_\_\_\_ Code \_\_\_\_\_ Starter Size \_\_\_\_\_

#### Special Options

DX Economizer  Frick Supplied Starter  PC Control System  Communications  VFD/VSD  Other

#### Prestart Checks

Position of all valves  All wiring connections  Motor rotation  Oil pump motor rotation  
 All micro settings  Cold alignment  Proper oil charge  Installation, Foundation

#### Factory Setup Options (Quantum™LX)

No Pump  Prelube  Cycling  Full Time  Dual  Oil Filter Transducer  Yes  No  
 Refrigerant \_\_\_\_\_ K-Factor for User Defined Refrigerant \_\_\_\_\_ Slide Valve Travel \_\_\_\_\_  
 Dual Discharge Control  Enabled  Disabled Liquid Injection Cooling  Enabled  Disabled  
 Main Oil Injection Control  Enabled  Disabled Balance Piston Setup  Enabled  Disabled  
 Oil Log Setup  Enabled  Disabled Enable Aux 1 & 2  None  1  2  Both



**Adjustable Safety Setpoints**

High Discharge Pressure Stop Load \_\_\_\_\_ Force Unload \_\_\_\_\_ Alarm \_\_\_\_\_ Delay \_\_\_\_\_ Shutdown \_\_\_\_\_ Delay \_\_\_\_\_  
 High Discharge Temp. Stop Load \_\_\_\_\_ Force Unload \_\_\_\_\_ Alarm \_\_\_\_\_ Delay \_\_\_\_\_ Shutdown \_\_\_\_\_ Delay \_\_\_\_\_  
 Motor Amps \_\_\_\_\_ Volts \_\_\_\_\_ Service Factor \_\_\_\_\_ Horsepower \_\_\_\_\_ CT Factor \_\_\_\_\_ Recycle Delay \_\_\_\_\_  
 Low Motor Amps Shutdown \_\_\_\_\_ Delay \_\_\_\_\_ Force Unload Inhibit Delay \_\_\_\_\_  
 High Motor Amps Stop Load \_\_\_\_\_ Force Unload \_\_\_\_\_ Alarm \_\_\_\_\_ Delay \_\_\_\_\_ Shutdown \_\_\_\_\_ Delay \_\_\_\_\_  
 High Oil Temperature Alarm \_\_\_\_\_ Delay \_\_\_\_\_ Shutdown \_\_\_\_\_ Delay \_\_\_\_\_  
 Low Oil Temperature Alarm \_\_\_\_\_ Delay \_\_\_\_\_ Shutdown \_\_\_\_\_ Delay \_\_\_\_\_ High Level Shutdown Delay \_\_\_\_\_  
 Low Separator Oil Temp. Alarm \_\_\_\_\_ Delay \_\_\_\_\_ Shutdown \_\_\_\_\_ Delay \_\_\_\_\_

**Operating Log Sheet**

Date							
Time							
Hour Meter Reading							
Equip. Room Temp.							
Suction Pressure							
Suction Temperature							
Suction Superheat							
Discharge Pressure							
Discharge Temperature							
Corresponding Temperature							
Oil Pressure							
Oil Temperature							
Oil Filter Pressure Drop							
Separator Temperature							
Slide Valve Position							
Volume Ratio (VI)							
Motor Amps / FLA %							
Capacity Control Setpoint							
Oil Level							
Oil Added							
Seal Leakage (Drops/Min.)							

**VIBRATION DATA SHEET**

Date: \_\_\_\_\_  
End User: \_\_\_\_\_  
Address: \_\_\_\_\_

Sales Order Number: \_\_\_\_\_  
Installing Contractor: \_\_\_\_\_  
Service Technician: \_\_\_\_\_

Equipment ID (As in Microlog): \_\_\_\_\_  
Compressor Serial Number: \_\_\_\_\_  
Unit Serial Number: \_\_\_\_\_  
National Board Number: \_\_\_\_\_  
Running Hours: \_\_\_\_\_  
Manufacturer and Size of Coupling: \_\_\_\_\_  
Motor Manufacturer: RAM \_\_\_\_\_  
Motor Serial Number: \_\_\_\_\_  
RPM: \_\_\_\_\_ Frame Size: \_\_\_\_\_ H.P. \_\_\_\_\_  
Refrigerant: \_\_\_\_\_  
Ambient Room Temperature: \_\_\_\_\_ °F  
Operating Conditions: \_\_\_\_\_

SUCTION		DISCHARGE		OIL		SEPARATOR		Slide Valve Position	%
Press	#	Press	#	Press	#	Temp	°F	V.I. Ratio	
Temp	°F	Temp	°F	Temp	°F			F.L.A.	%

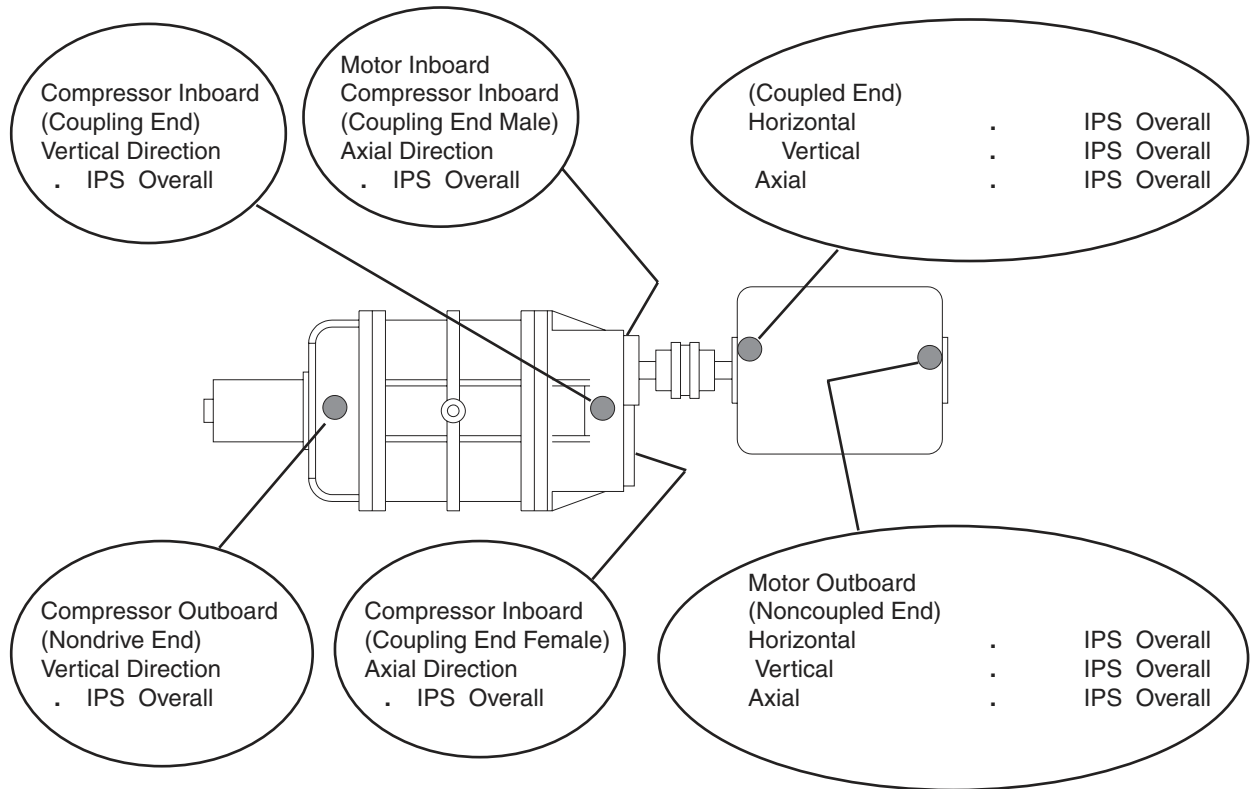



**RECOMMENDED SPARE PARTS - CURRENT DESIGN**

(When ordering parts, provide the Model, Serial, and Frick Sales Order Numbers from the data plates.)

DESCRIPTION	QTY.	MODEL	ITEM NUMBER
<b>QUANTUM™LX CONTROL:</b>			
Assembly, VGA Display, Sharp (Display only, 333Q0001581)	1	ALL	640C0021G01
Inverter, Sharp (part of 640C0021G01 Assembly above)	1	ALL	333Q0001582
Power Supply	1	ALL	640C0022G01
Cable, CPU to Display/Inverter	1	ALL	649B0913H01
Keypad, Overlay (Quantum™LX)	1	ALL	640D0186H01
Keypad, Overlay (Quantum™)	1	ALL	640D0060H01
Board, Analog #1	1	ALL	640C0057G01
Board, Digital #1	1	ALL	640C0024G01
Module, Output, 280V (For 115/230V)	2	ALL	111Q0281061
Module, Input, 90-140V (For 115V)	1	ALL	333Q0000116
Fuse, 5 Amp, 250V, I/O Board	4	ALL	333Q0001326
Relay, 3PDT, 115V	1	ALL	333Q0000206
Relay, 2PDT, 24VDC	1	ALL	333Q0001095
Fuse, 2 Amp, EZ-Cool™ Transformer	1	ALL	333Q0001672
Flash Card ( <b>To order, contact Frick Controls</b> )	1	ALL	—
<b>UNIT:</b>			
Sensor, Temperature Probe	1	12—50	640A0035H01
Sensor, Temperature Probe	1	58—101	639A0151G01
Transducer, Pressure, 0—200 PSIA	1	ALL	913A0124H01
Transducer, Pressure, 0—500 PSIA	1	ALL	913A0124H02
Valve, Solenoid, Yuken 120/60 & 110/50	1	ALL	951A0103H01
Valve, Solenoid, Yuken 240/60 & 220/50	1	ALL	951A0103H02
Coil For 951A0103H01 Above	2	ALL	951A0103H05
Coil For 951A0103H02 Above	2	ALL	951A0103H06
Heater, Oil, 500W, 120V	1	ALL	913A0092G01
Switch, Liquid Level w/1" Reducing Bushing	1	12—50	913A0086H01
Switch, Oil Level Sensing, 24V	1	58—101	913A0123H01
Filter, Coalescing	1	12—19	531B0065H06
Filter, Coalescing (Demistifier™ with drain feature)	1	24—50	531B0099H02
Filter, Coalescing (Demistifier™ with drain feature)	1	58 & 68	531B0099H01
Filter, Coalescing (Demistifier™ with drain feature)	2	85 & 101	531B0099H01
Gasket, Separator Access Cover	1	12—19	959A0090H02
Gasket, Separator Access Cover	1	24—50	959A0090H03
Gasket, Separator Manway	1	58 & 68	531A0105H03
Gasket, Separator Manway	1	85 & 101	531A0105H04
Cartridge, Oil Filter, SuperFilter™II (Required for 1-2-3 Warranty)	1	12—50	535A0354H02
Element, Filter, Oil, SuperFilter™II (Required for 1-2-3 Warranty)	1	58—101	531A0224H01
Gasket, for 531A0224H01 above	1	58—101	959A0082H02
Kit, Shaft Seal, XJF 95	1	12—19	111Q0043229
Kit, Shaft Seal, XJF 120	1	24—50	111Q0043231
Kit, Shaft Seal, XJF 151	1	58—101	534M0602G02

**NOTE: This list is based on one standard unit. When stocking for more than one unit, the quantity should be adjusted to meet your individual requirements.**

## Index

### B

back flushing, 9  
battery backup, 11  
booster applications, 12  
brownouts, 11

### C

chemical cleaning process, 9  
CH Coupling Data Table, 5  
clamping bolts, 5  
closed-loop fluids, 8  
closed-loop system, 8  
coalescer, 13  
coalescer filter element, 6  
cold-start valve, 12  
Compressor  
  motor, 10  
compressor motor starter, 10  
Compressor Port Locations -  
  RXF 12 - 19, 35  
  RXF 24 - 50, 36  
  RXF 58 - 101, 37  
compressor shaft, 5  
Compressor Unloading, 13  
compressor volume ratio, 13,14  
control power regulator, 11  
cooling tower water, 8  
cooling water, 8  
coupling, 10  
Current Transformer, 11

### D

DEMAND PUMP, 25  
  ASSEMBLY, 26  
  ball bearing, 26  
  bearings, 25  
  bearing housing, 27  
  bearing retainer washer, 25  
  bearing spacer, 25,26  
  bearing spacer collar, 27  
  Carbon Graphite Bushings, 25  
  carbon graphite bushings, 27  
  carbon seal rotating face, 26  
  DISASSEMBLY, 25  
  double-row ball bearing, 26  
  idler pin, 26  
  lip seal, 25  
  O-ring gasket, 26  
  Pressure Gauge - Discharge Port, 28  
  rotor hub, 26  
  rotor shaft, 26  
  seal housing bore, 26  
  seal seat, 25  
  seal spring, 26  
  shaft snap ring, 26  
  single-row ball bearing, 25  
  snap ring, 25  
  Standard Mechanical Seal, 26  
  tapered installation sleeve, 26

  thrust-bearing assembly, 26,27  
  thrust bearing assembly, 25  
  TROUBLESHOOTING, 27  
    Rapid Wear, 28  
  Vacuum Gauge—Suction Port, 27  
Demand Pump  
  ASSEMBLY, 26  
  ball bearing, 25  
  single row ball bearing, 26  
  bearing retainer washer, 25,26  
  bearing spacer, 25,26  
  bearing spacer collar, 27  
  carbon-graphite bushings, 25,26,27  
  casing, 25  
  DISASSEMBLY, 25  
  End Clearance, 27  
  idler, 25  
  idler pin, 25,26  
  lip seal, 25,27  
  Mechanical Seal, 26  
  O-ring gasket, 26  
  pump head, 26  
  refrigeration oil, 26  
  seal face, 26  
  seal seat, 26  
  seal spring, 26  
  shaft snap ring, 26  
  snap ring, 25,27  
  tapered installation sleeve, 26  
  thrust-bearing assembly, 25,27  
  Thrust Bearing Adjustment, 27  
  Troubleshooting  
    bent shaft, 28  
    cavitating, 28  
    cavitation, 27  
    Discharge Port, 28  
    Discharge pressure, 28  
    discharge valve, 28  
    Fluttering, 27,28  
    Gate valve, 28  
    High viscosity, 28  
    jumping, 27  
    misalignment, 27,28  
    Relief valve, 28  
    Relief valve poppet, 28  
    Starving, 28  
    Strainer, 28  
    suction port, 27  
    Suction valve, 28  
    vacuum gauge, 27  
    Vibrating, 28  
  Viking Pump, 25  
  differential pressure, 12  
  Direct Expansion Economizer  
    System, 9  
  direct motor drive, 5  
  double-acting solenoid valve, 14  
  drive hubs, 5  
  dry nitrogen, 5  
  DX economizer, 9

### E

ECONOMIZER, 9  
  back-pressure regulator valve, 9  
  balancing load, 10  
  check valve, 9  
  DX economizer, 9  
  economizer port, 9  
  flashing liquid, 9  
  flash vessel, 9  
  isolation valve, 9  
  microprocessor, 9  
  outlet pressure regulator, 9  
  strainer, 9  
  subcooling liquid, 9  
elastomeric gear, 5  
external controller, 10  
EZ-Cool™LIOC  
  analog board #1, 15  
  analog output #1, 15  
  Control Input, 15  
  Control Setpoint, 15  
  Dead Band, 15  
  Delta, 15  
  Derivative Gain, 15  
  discharge temperature, 16  
  Integral Gain, 15  
  Liquid Slugging, 16  
  meter, 15  
  operating session, 15  
  P11A terminal strip, 15  
  PID #1, 15  
  PID Output value, 15  
  Proportional Band, 15  
  Proportional Gain, 15  
  Quantum™LX Control Panel, 15  
  terminal strip, 15

### F

filter elements, 6  
Flash Economizer System, 9  
flexible drive coupling, 5  
forklift, 5  
FOUNDATION, 4,12  
  Anchor bolts, 4  
  grout, 4  
  housekeeping pads, 4  
  I-beams, 4  
  pipe supports, 4  
  reinforced concrete, 4  
  vibration expert, 4

### H

HANDLING and MOVING, 4  
  crane, 4  
  forklift, 4  
  lifting ring, 5  
  rigging, 4  
  spreader bars, 5  
hard water conditions, 8

heat exchanger, 8  
high-stage operation, 12  
hydraulic system, 13

## J

jack, 5

## L

liquid carryover, 6  
liquid injection, 8,14  
  Alarms, 17  
  analog input signal, 17  
  Common Digital Alarm, 17  
  Danfoss Liquid Injection Valve, 18  
  digital Input signal, 17  
  Display, 17  
  dual dip tube method, 8  
  Enter push button, 17  
  Hansen Liquid Injection Valve, 19  
  24VDC power supply, 19  
    Calibration, 19  
    Power Head, 19  
    tool MOVT, 19  
  high-stage units, 8  
  ICAD (Industrial Control Actuator  
    with Display), 16  
  ICM valve, 17  
  low condensing pressures, 8  
  MMI (Man Machine Interface), 16  
  Mod, 17  
  Motorized Industrial Control Valve, 16  
  Opening Degree, 17  
  parameters, 16  
  Parameter list, 18  
    Analog Output signal, 18  
    Automatic calibration, 18  
    Digital Input function, 18  
    Fail-safe, 18  
    ICM configuration, 18  
    Main Switch, 18  
    Mode, 18  
    Modulating Mode, 18  
    Old Alarms, 18  
    Password, 18  
  solenoid valve, 17  
liquid refrigerant, 14  
low voltage, 10  
lubrication system, 12

## M

MAINTENANCE, 21  
  Bare Compressor Mounting, 33  
  bearing failure, 21  
  coalescer filter element, 24  
  daily log, 28  
  discharge service valve, 24  
  DISCONNECT POWER, 21  
  disconnect switches, 22  
  drain valve, 23,24  
  dry nitrogen, 21  
  ISOLATION VALVES, 21  
  isolation valves, 22

liquid injection strainer, 23  
liquid injection valves, 21  
liquid refrigerant, 21  
low pressure transducer, 22  
motor bearings, 29  
  lubrication, 29  
nuisance oil level cutouts, 24  
oil-charging valve, 24  
oil analysis testing, 28  
oil cooler, 24  
Oil entrained refrigerant, 22,24  
oil filters, 22  
oil filter element, 24  
oil foaming, 23  
oil pressure loss, 24  
oil pump strainer, 23  
Oil quality, 28  
operating log, 29  
Operating Log Sheet, 49  
pressure sensors, 33  
PRESSURE TRANSDUCERS, 30  
  Conversion Data, 31  
  Replacement, 31  
  Testing, 30  
Proper Installation Of Electronic  
  Equipment, 46  
P & I Diagram, 38  
Recommended Spare Parts, 54  
refrigerant vapor, 22,24  
Safety Equipment, 21  
service valves, 22  
solenoid valves, 22  
spin-on oil filter element, 22  
starting torque, 23  
strainer elements, 24  
strainer service valves, 23  
suction check valve bypass, 22,24  
suction service valve, 24  
suction strainer, 21  
suction valve bypass, 23  
superheat, 21  
Troubleshooting.*see Index*,  
  Troubleshooting  
Ventilation, 21  
vibration analysis, 28  
Vibration Data Sheet, 53  
vibration level, 21  
water vapor, 21  
Wiring Harness, 44  
Maintenance  
  DIN connector plug, 32  
  linear transmitter, 32  
  Maintenance Schedule, 29  
  oil level control, 32  
  Oil Level Transmitter, 32  
  sensor well, 32  
  temperature sensor, 32  
  Temperature Transmitter, 32  
  volume ratio control, 32  
microprocessor, 9,14  
motor, 10  
motor contactor, 10  
Motor cycling, 10

motor rotation, 5  
motor starter contactor, 10  
mounting bolts, 5  
movable slide valve, 13  
Multiple Compressor Economizer  
  System, 9

## N

neoprene drive spacer, 5

## O

oil charge reservoir, 13  
oil charging valve, 6  
Oil distillers, 6  
oil filter, 6  
oil heaters, 6  
oil pressure alarm, 13  
oil pressure cutout, 13  
operating volume ratio, 14

## P

pH, 8  
power fluctuations, 11  
Prestart Checklist, 50

## Q

Quantum™ LX, 10  
Quantum™ LX control system, 10  
Quantum™ panel, 10

## R

recovery procedure, 24  
RXF rotary screw compressor, 12  
  Moveable slide valve, 12  
  shaft seal, 12  
  volumizer slide stop, 12

## S

SBC Board, 10  
scaling, 8  
self-lubricating, 12  
separator, 5  
severe water conditions, 8  
Shell And Coil Economizer System, 9  
shipping gauges, 6  
shutdown, 21  
  liquid injection, 21  
  package valves, 21  
  solenoid valves, 21  
  strainers, 21  
sight glass, 6,13  
single-port liquid injection, 14  
slide stop, 20  
slide valve, 20  
slide valve piston, 13  
Sola® constant voltage (CV)  
  transformer, 10  
solenoid valve, 14  
start-up, 20  
  slide valve potentiometer, 20  
  suction strainer, 20

Start-up Report, 51  
starter package wiring diagram, 10  
strainer, 8,24  
suction check valve bypass, 13,24  
suction housing, 5

## T

TCV, 14  
temperature control valve, 14  
temperature sensor, 14  
Thermosyphon Oil Cooling, 14  
Thermosyphon oil cooling, 6,7  
    condensing pressure, 6  
    drain valve, 7  
    liquid refrigerant, 7  
    refrigerant-side safety valve, 7  
    thermostatically controlled mixing valve, 7  
    vapor mixture, 7  
Welding, 7  
Troubleshooting, 33  
    Excessive Noise And Vibration, 33  
    Gradual Oil Loss, 33  
    High Oil Temperature, 34  
    Low Oil Temperature, 34  
    Oil Temperature Fluctuates, 34  
    Rapid Oil Loss, 33  
    Slide Valve, 34

## U

UPS, 10  
UPS power system, 10

## V

vessel, 6

## W

Water-Cooled Oil Cooling, 14  
water-cooled oil coolers, 14  
water treatment, 8





# Q-NET™ network technology...

## Make the Connection with QUANTUM™!

Take full advantage of Q-NET™ technology with all Frick® products!

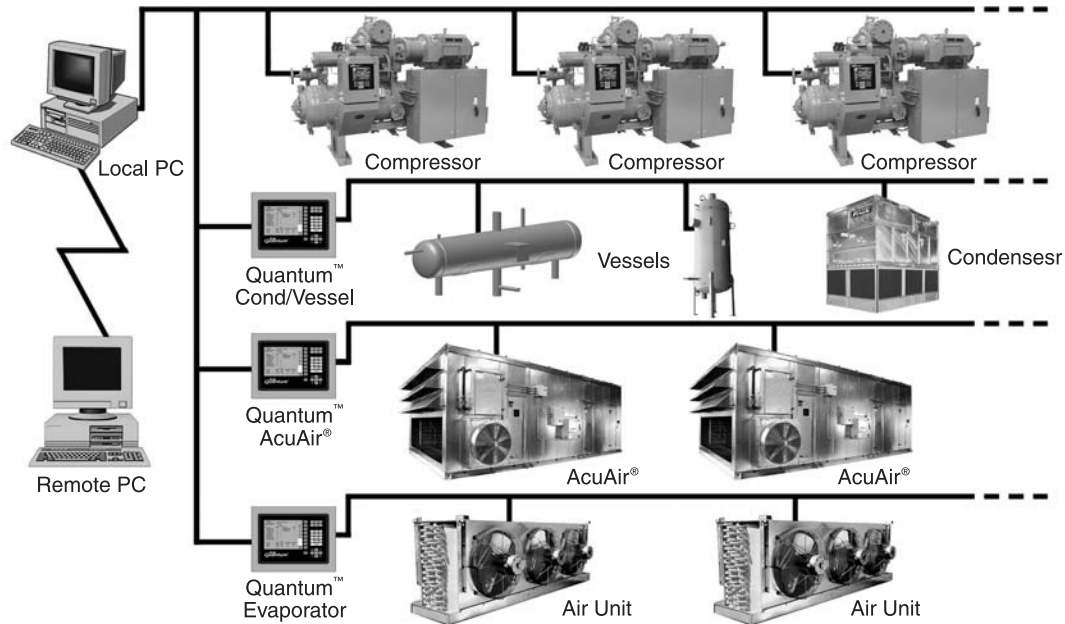

## System integration is what we do...

- Q-NET™ ... supports open-protocols for your SCADA system (i.e. Allen Bradley DF1 and Modbus ASCII)
- Q-NET™ ... connects for local or remote access
- Q-NET™ ... can be applied to both new and existing systems

Q-NET™ means precise control 24 hours a day, seven days a week

Q-NET™ distributed architecture means faster, easier, economical installations

Q-NET™ delivers increased operating efficiency and lowers energy costs

Now available on Frick's AcuAir® hygienic air handlers, condensers, screw compressors, evaporators, and refrigerant vessels, too.

## Take Control!™

Form S70-400 IOM (306)  
Supersedes: S70-400 IOM (801)  
Subject to change without notice  
Printed in USA • GUI 2000 306 6.00

© 2006 Johnson Controls Inc. - ALL RIGHTS RESERVED

**Frick**  
A JOHNSON CONTROLS COMPANY

FRICK  
100 CV Avenue • P.O. Box 997  
Waynesboro, PA USA 17268-0997  
Phone: 717-762-2121 • FAX: 717-762-8624  
[www.frickcold.com](http://www.frickcold.com)