



BY JOHNSON CONTROLS

Form 070-600 IOM (APR 2009)

INSTALLATION - OPERATION - MAINTENANCE

File: EQUIPMENT MANUAL - Section 70
Replaces: S70-600 IOM/OCT 2004
Dist: 3, 3a, 3b, 3c

RWF

ROTARY SCREW COMPRESSOR UNITS

ALL REFRIGERANTS

MODELS

100 through 480

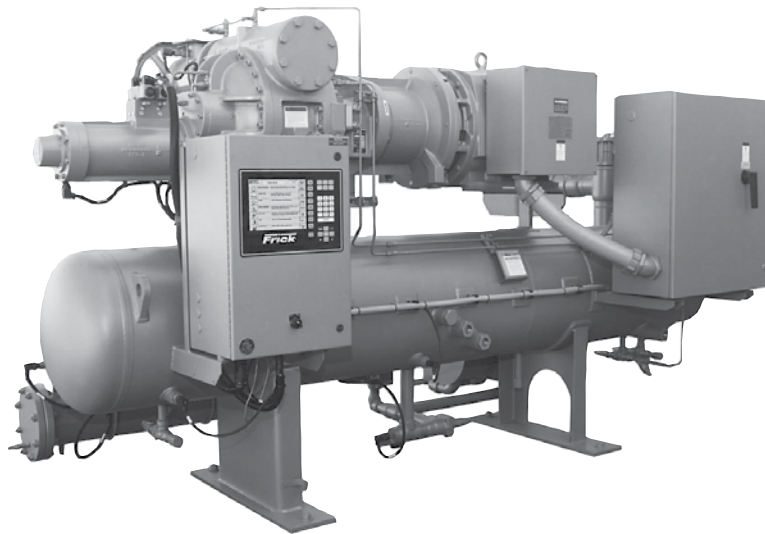

**THIS MANUAL CONTAINS RIGGING, ASSEMBLY, START-UP,
AND MAINTENANCE INSTRUCTIONS. READ THOROUGHLY
BEFORE BEGINNING INSTALLATION. FAILURE TO FOLLOW THESE
INSTRUCTIONS COULD RESULT IN DAMAGE OR IMPROPER
OPERATION OF THE UNIT.**

Please check www.johnsoncontrols.com for the latest version of this publication.

Contents

PREFACE.....	3
DESIGN LIMITATIONS.....	3
JOB INSPECTION.....	3
TRANSIT DAMAGE CLAIMS.....	3
COMPRESSOR and UNIT IDENTIFICATION.....	3

INSTALLATION

FOUNDATION.....	4
RIGGING and HANDLING.....	4
SKID REMOVAL.....	4
CHECKING MOTOR/COMPRESSOR ROTATION.....	5
COMPRESSOR/MOTOR COUPLING INSTALLATION.....	5
BPU SERIES COUPLING DATA TABLE.....	5
OIL PUMP COUPLING.....	5
HOLDING CHARGE AND STORAGE.....	5
COMPRESSOR UNIT OIL.....	5
OIL CHARGE.....	6
OIL HEATER(S).....	6
OIL FILTER(S).....	6
THERMOSYPHON OIL COOLING.....	6
LIQUID INJECTION OIL COOLING (Optional).....	7
LIQUID LINE SIZES/RECEIVER VOLUME.....	8
WATER-COOLED OIL COOLING (OPTIONAL).....	8
ECONOMIZER - HIGH STAGE (OPTIONAL).....	9
ELECTRICAL.....	10
MOTOR STARTER PACKAGE.....	10
CURRENT TRANSFORMER (CT) RATIOS.....	11
MINIMUM BURDEN RATINGS.....	11
BATTERY BACKUP.....	12

OPERATION

OPERATION and START-UP INSTRUCTIONS.....	13
SGC COMPRESSOR.....	13
COMPRESSOR LUBRICATION SYSTEM.....	13
NO PUMP OIL SYSTEM.....	13
COLD-START SYSTEM.....	14
DEMAND PUMP OIL SYSTEM.....	14
COMPRESSOR OIL SEPARATION SYSTEM.....	14
COMPRESSOR HYDRAULIC SYSTEM.....	15
VOLUMIZER VOLUME RATIO CONTROL.....	15
COMPRESSOR OIL COOLING SYSTEMS.....	16
SINGLE-PORT LIQUID INJECTION.....	16
BOOSTER OR SWING DUTY APPLICATION.....	16
DUAL-PORT LIQUID INJECTION.....	16
LIQUID INJECTION ADJUSTMENT.....	16
EZ-COOL™ LIQUID INJECTION ADJUSTMENT.....	17
SUCTION CHECK VALVE BYPASS.....	19
LOW AMBIENT OPERATION.....	19
INITIAL START-UP.....	20
INITIAL START-UP PROCEDURE.....	20
NORMAL START-UP PROCEDURE.....	20

MAINTENANCE

GENERAL INFORMATION.....	21
NORMAL MAINTENANCE OPERATIONS.....	21
GENERAL MAINTENANCE.....	21
COMPRESSOR SHUTDOWN and START-UP.....	21
GENERAL INSTRUCTIONS FOR REPLACING COMPRESSOR UNIT COMPONENTS.....	22
OIL FILTER (OF-1) MAIN SINGLE/DUAL.....	22
STRAINER - DEMAND OIL PUMP.....	22
STRAINER - LIQUID INJECTION.....	23
COALESCER FILTER ELEMENT(S).....	23
CHANGING OIL.....	23
DEMAND PUMP.....	24
PREVENTATIVE MAINTENANCE.....	27
RECOMMENDED MAINTENANCE PROGRAM.....	27
VIBRATION ANALYSIS.....	28
OIL QUALITY and ANALYSIS.....	28
OPERATING LOG.....	28
MOTOR BEARINGS.....	28
MAINTENANCE SCHEDULE.....	28
TROUBLESHOOTING GUIDE.....	29
ABNORMAL OPERATION ANALYSIS and CORRECTION.....	29
SERVICING THE COLD-START VALVE.....	30
PRESSURE TRANSDUCERS.....	31
SV POSITION POTENTIOMETER REPLACEMENT AND ADJUSTMENT.....	32
CAPACITY LINEAR TRANSMITTER REPLACEMENT - SLIDE VALVE.....	32
VOLUMIZER® TRANSMITTER REPLACEMENT - SLIDE STOP.....	33
TEMPERATURE SENSOR REPLACEMENT.....	33
OIL LEVEL TRANSMITTER REPLACEMENT.....	33
TROUBLESHOOTING THE RWF COMPRESSOR.....	34
OIL SEPARATION SYSTEM.....	34
HYDRAULIC SYSTEM.....	35
LIQUID INJECTION OIL COOLING SYSTEM.....	35
DEMAND PUMP SYSTEM.....	36
THERMAL EXPANSION VALVES.....	37
JORDAN TEMPERATURE REGULATOR VALVE.....	38
MOTOR REPLACEMENT.....	39
BARE COMPRESSOR REPLACEMENT.....	39
P & I DIAGRAMS.....	40
WIRING HARNESS.....	44
PROPER INSTALLATION OF ELECTRONIC EQUIPMENT IN AN INDUSTRIAL ENVIRONMENT.....	49
FORMS.....	54
INDEX.....	61

SAFETY PRECAUTION DEFINITIONS



Indicates an imminently hazardous situation which, if not avoided, will result in death or serious injury.



Indicates a potentially hazardous situation or practice which, if not avoided, will result in death or serious injury.



Indicates a potentially hazardous situation or practice which, if not avoided, will result in damage to equipment and/or minor injury.

NOTE:

Indicates an operating procedure, practice, etc., or portion thereof which is essential to highlight.

PREFACE

This manual has been prepared to acquaint the owner and serviceman with the INSTALLATION, OPERATION, and MAINTENANCE procedures as recommended by Johnson Controls-Frick for RWF Rotary Screw Compressor Units.

For information about the functions of the *Quantum™* control panel, communications, specifications, and wiring diagrams, see publication series S90-010 O, M, CS, and E90-010 SPC.

It is most important that these units be properly applied to an adequately controlled refrigeration system. Your authorized Johnson Controls-Frick representative should be consulted for his expert guidance in this determination.

Proper performance and continued satisfaction with these units is dependent upon:

- CORRECT INSTALLATION**
- PROPER OPERATION**
- REGULAR, SYSTEMATIC MAINTENANCE**

To ensure correct installation and application, the equipment must be properly selected and connected to a properly designed and installed system. The Engineering plans, piping layouts, etc. must be detailed in accordance with the best practices and local codes, such as those outlined in ASHRAE literature.

A refrigeration compressor is a VAPOR PUMP. To be certain that it is not being subjected to liquid refrigerant carryover it is necessary that refrigerant controls are carefully selected and in good operating condition; the piping is properly sized and traps, if necessary, are correctly arranged; the suction line has an accumulator or slugging protection; that load surges are known and provisions made for control; operating cycles and defrosting periods are reasonable; and that high side condensers are sized within system and compressor design limits.

It is recommended that the entering vapor temperature to the compressor be superheated to 10°F above the refrigerant saturation temperature. This assures that all refrigerant at the compressor suction is in the vapor state.

DESIGN LIMITATIONS

The compressor units are designed for operation within the pressure and temperature limits as shown in Johnson Controls-Frick Pub. E70-600 SED (Check with Johnson Controls-Frick marketing dept. for availability).

JOB INSPECTION

Immediately upon delivery examine all crates, boxes and exposed compressor and component surfaces for damage. Unpack all items and check against shipping lists for any discrepancy. Examine all items for damage in transit.

TRANSIT DAMAGE CLAIMS

All claims must be made by consignee. This is an ICC requirement. Request immediate inspection by the agent of the carrier and be sure the proper claim forms are executed.

Report damage or shortage claims immediately to Johnson Controls-Frick Sales Administration Department, in Waynesboro, PA.

COMPRESSOR and UNIT IDENTIFICATION

Each compressor unit has 2 identification data plates. The **compressor data plate** containing compressor model and serial number is mounted on the compressor body. The **unit data plate** containing unit model, serial number and Johnson Controls-Frick sales order number is mounted on the side of the compressor base.

NOTE: When inquiring about the compressor or unit, or ordering repair parts, provide the MODEL, SERIAL, and Johnson Controls-FRICK SALES ORDER NUMBERS from these data plates.

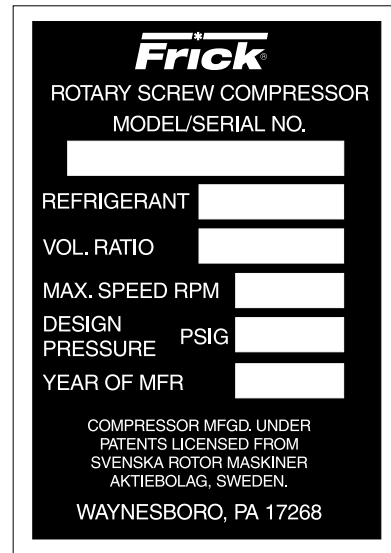

COMPRESSOR DATA PLATE

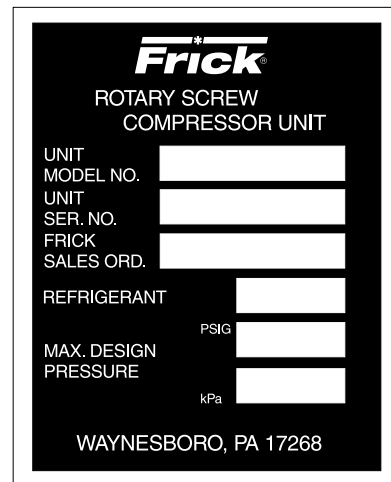

UNIT DATA PLATE

Installation

FOUNDATION

Each RWF Rotary Screw Compressor Unit is shipped mounted on a wood skid which **must** be removed prior to unit installation.



Allow space for servicing the unit per factory drawings.

The first requirement of the compressor foundation is that it must be able to support the weight of the compressor package including coolers, oil, and refrigerant charge. Screw compressors are capable of converting large quantities of shaft power into gas compression in a relatively small space and a mass is required to effectively dampen these relatively high frequency vibrations.

Firmly anchoring the compressor package to a suitable foundation by proper application of grout and elimination of piping stress imposed on the compressor is the best insurance for a trouble-free installation. Use only the certified general arrangement drawings from Frick to determine the mounting foot locations and to allow for recommended clearances around the unit for ease of operation and servicing. Foundations must be in compliance with local building codes and materials should be of industrial quality.

The floor should be a minimum of 6 inches of reinforced concrete and housekeeping pads are recommended. Anchor bolts are required to firmly tie the unit to the floor. Once the unit is rigged into place (See RIGGING and HANDLING), the feet must then be shimmed in order to level the unit. The shims should be placed to position the feet roughly one inch above the housekeeping pad to allow room for grouting. An expansion-type epoxy grout must be worked under all areas of the base with no voids and be allowed to settle with a slight outward slope so oil and water can run off of the base.

When installing on a steel base, the following guidelines should be implemented to properly design the system base:

1. Use I-beams in the skid where the screw compressor will be attached to the system base. They should run parallel to the package feet and support the feet for their full length.
2. The compressor unit feet should be continuously welded to the system base at all points of contact.
3. The compressor unit should not be mounted on vibration isolators in order to hold down package vibration levels.
4. The customer's foundation for the system base should fully support the system base under all areas, but most certainly under the I-beams that support the compressor package.

When installing on the upper floors of buildings, extra precautions should be taken to prevent normal package vibration from being transferred to the building structure. It may be necessary to use rubber or spring isolators, or a combination of both, to prevent the transmission of compressor vibration directly to the structure. However, this may increase package vibration levels because the compressor is not in contact with any damping mass. The mounting and support of suction and discharge lines is also very important. Rubber or spring pipe supports may be required to avoid exciting the building structure at any pipe supports close to the compressor package. It is best to employ a vibration expert in the design of a proper mounting arrangement.

In any screw compressor installation, suction and discharge lines should be supported in pipe hangers (preferably within 2 ft. of vertical pipe run) so that the lines won't move if disconnected from the compressor. See table for Allowable Flange Loads.

NOZ. SIZE NPS	ALLOWABLE FLANGE LOADS					
	MOMENTS (ft-lbf)			LOAD (lbf)		
	AXIAL	VERT.	LAT.	AXIAL	VERT.	LAT.
	M _R	M _C	M _L	P	V _C	V _L
1	25	25	25	50	50	50
1.25	25	25	25	50	50	50
1.5	50	40	40	100	75	75
2	100	70	70	150	125	125
3	250	175	175	225	250	250
4	400	200	200	300	400	400
5	425	400	400	400	450	450
6	1,000	750	750	650	650	650
8	1,500	1,000	1,000	1,500	900	900
10	1,500	1,200	1,200	1,500	1,200	1,200

Frick® recommends consulting a licensed architect to determine the proper foundation requirements for any large engine or turbine drive.

When applying screw compressors at high pressures, the customer must be prepared for package vibration and noise higher than the values predicted for normal refrigeration duty. Proper foundations and proper installation methods are vital; and even then, sound attenuation or noise curtains may be required to reduce noise to desired levels.

For more detailed information on Screw Compressor Foundations, please request Frick® publication S70-210 IB.

RIGGING and HANDLING



This screw compressor package may be top-heavy. Use caution in rigging and handling.

The unit can be moved with rigging, using a crane or forklift, by hooking into the four lifting eyes on the oil separator. If a motor is mounted, appropriate adjustment in the lifting point should be made to compensate for motor weight. Adjustment of the lifting point must also be made for any additions to the standard package such as an external oil cooler, etc., because the center of balance will be effected.

The unit can be moved with a forklift by forking under the skid, or it can be skidded into place with pinch bars by pushing against the skid. **NEVER MOVE THE UNIT BY PUSHING OR FORKING AGAINST THE SEPARATOR SHELL OR ITS MOUNTING SUPPORTS.**

SKID REMOVAL

If the unit is rigged into place, the skid can be removed by taking off the nuts and bolts that are fastening the unit mounting supports to the skid before lowering the unit onto the mounting surface.

If the unit is skidded into place, remove the cross members from the skid and remove the nuts anchoring the unit to the skid. Using a 10-ton jack under the separator raise the unit at the compressor end until it clears the two mounting bolts. Spread the skid to clear the unit mounting support, then lower the unit to the surface. Repeat procedure on opposite end.

CHECKING MOTOR/COMPRESSOR ROTATION

- WARNING** Make sure coupling hubs are tightened to the shaft before rotating the motor to prevent them from flying off and possibly causing serious injury or death.
- CAUTION** Injury may occur if loose clothing, etc, becomes entangled on the spinning motor shaft.

COMPRESSOR ROTATION IS CLOCKWISE WHEN FACING THE END OF THE COMPRESSOR SHAFT. Under NO conditions should the motor rotation be checked with the coupling center installed as damage to the compressor may result. Bump the motor to check for correct compressor rotation. After verification, install disk drive spacer, as applicable.

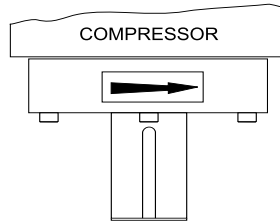

COMPRESSOR/MOTOR COUPLING INSTALLATION

The RWF unit has compressor to motor alignment through the use of a machined cast iron tunnel. This tunnel is factory set through machining tolerances ensuring motor compressor alignment. **No alignment is required in the field.** See Figure 1.

1. Install the motor and compressor coupling hubs and keys on their respective shafts. Ensure that they can slide horizontally so that once the **disc packs** are installed, no axial stress is transferred to the disc packs by a stuck coupling hub. Use no lubricants.
2. Rotate both hubs so that the keys are 180° opposed. Install the disc packs and coupling center sleeve. Torque the disc pack screws as recommended in the COUPLING DATA TABLE.
3. Center the coupling between the shafts. Ensure that the keys are fully engaged in their keyways.
4. Torque the keyway setscrews as recommended in the COUPLING DATA TABLE.

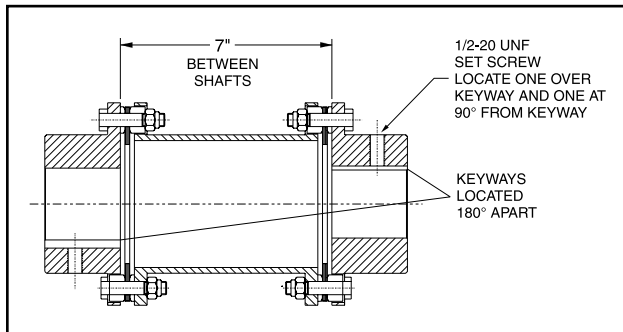

Figure 1 - Model BPU Coupling

BPU SERIES COUPLING DATA TABLE

BPU SERIES	DISC PACK LOCKNUT TORQUE (LUBE)		KEYWAY SETSCREW TORQUE	
	ft-lb	Nm	ft-lb	Nm
BPU 38	22	29.8	13	17.6
BPU 41	55	74.6	13	17.6
BPU 47	120	162.7	13	17.6
BPU 54	120	162.7	13	17.6

OIL PUMP COUPLING

Compressor units with direct motor/pump coupled pumps need no pump/motor coupling alignment since this is maintained by the close-coupled arrangement.

HOLDING CHARGE AND STORAGE

Each RWF compressor unit is pressure and leak tested at the Johnson Controls-Frick factory and then thoroughly evacuated and charged with dry nitrogen to ensure the integrity of the unit during shipping and short term storage prior to installation.

NOTE: Care must be taken when entering the unit to ensure that the nitrogen charge is safely released.

WARNING Holding-charge shipping gauges on separator and external oil cooler are rated for 30 PSIG and are for checking the shipping charge only. They must be removed before pressure testing the system and before charging the system with refrigerant. Failure to remove these gauges may result in catastrophic failure of the gauge and uncontrolled release of refrigerant resulting in serious injury or death.

All units must be kept in a clean, dry location to prevent corrosion damage. Reasonable consideration must be given to proper care for the solid-state components of the microprocessor.

Please contact Johnson Controls-Frick service for long term storage requirements.

COMPRESSOR UNIT OIL

WARNING DO NOT MIX OILS of different brands, manufacturers, or types. Mixing of oils may cause excessive oil foaming, nuisance oil level cutouts, oil pressure loss, gas or oil leakage and catastrophic compressor failure.

NOTE: The oil charge shipped with the unit is the best suited lubricant for the conditions specified at the time of purchase. If there is any doubt due to the refrigerant, operating pressures, or temperatures, refer to Pub. E160-802 SPC on Frick oil for guidance.

OIL CHARGE

The normal charging level is midway in the top sight glass located midway along the oil separator shell. Normal operating level is midway between the top and bottom sight glass. The table gives the approximate oil charge quantity.

*Includes total in oil separator and piping. Add 5 gal. for oil cooler up to Model 270, 10 gal. for 316 - 480.

RWF MODEL NO.	BASIC* CHARGE (gal.)
100	55
134	55
177	120
222	120
270	120
316	140
399	140
480	150

Add oil by attaching the end of a suitable pressure type hose to the oil charging valve, located on the top of the oil separator between the compressor and motor. Using a pressure-type pump and the recommended Frick® oil, open the charging valve and pump oil into the separator. **NOTE: Fill slowly because oil will fill up in the separator faster than it shows in the sight glass.**

Oil distillers and similar equipment which act to trap oil must be filled prior to unit operation to normal design outlet levels. The same pump used to charge the unit may be used for filling these auxiliary oil reservoirs.

NOTE: The sight glass located in the coalescing end of the separator near the discharge connection should remain empty.

OIL HEATER(S)

Standard units are equipped with two or three 500 watt oil heaters, providing sufficient heat to maintain the oil temperature for most indoor applications during shutdown cycles to permit safe start-up. Should additional heating capacity be required because of low ambient temperature, contact Frick®. The heaters are energized only when the unit is not in operation.

WARNING DO NOT ENERGIZE THE HEATERS when there is no oil in the unit, the heaters will burn out. The oil heaters will be energized whenever 120 volt control power is applied to the unit and the compressor is not running, unless the 16 amp circuit breaker in the micro enclosure is turned off.

OIL FILTER(S)

CAUTION Use of filter elements other than Frick may cause warranty claim to be denied.

The oil filter(s) and coalescer filter element(s) shipped with the unit are best suited to ensure proper filtration and operation of the system.

THERMOSYPHON OIL COOLING

Thermosyphon oil cooling is an economical, effective method for cooling oil on screw compressor units. Thermosyphon cooling utilizes liquid refrigerant at condenser pressure and temperature that is partially vaporized at the condenser temperature in a plate and shell vessel, cooling the oil to within 15°F of that temperature. The vapor, at condensing pressure, is vented to the condenser inlet and reliquified. This method is the most cost effective of all currently applied cooling systems since no compressor capacity is lost or compressor power penalties incurred. The vapor from the cooler need only be

condensed, not compressed. Refrigerant flow to the cooler is automatic, driven by the thermosyphon principle and cooling flow increases as the oil inlet temperature rises.

EQUIPMENT - The basic equipment required for a thermosyphon system consists of:

1. A source of liquid refrigerant at condensing pressure and temperature, located in close proximity to the unit to minimize piping pressure drop. The liquid level in the refrigerant source must be 6 to 8 feet minimum above the center of the oil cooler.
2. A plate and shell oil cooler with:
 - Plate Side: Oil 400 lb design
 - Shell Side: Refrigerant 400 lb design

Due to the many variations in refrigeration system design and physical layout, several systems for assuring the above criteria are possible.

SYSTEM OPERATION - Liquid refrigerant fills the cooler shell side up to the Thermosyphon receiver liquid level.

Hot oil (above the liquid temperature) flowing through the cooler will cause some of the refrigerant to boil and vaporize. The vapor rises in the return line. The density of the refrigerant liquid/vapor mixture in the return line is considerably less than the density of the liquid in the supply line. This imbalance provides a differential pressure that sustains a flow condition to the oil cooler. This relationship involves:

1. Liquid height above the cooler.
2. Oil heat of rejection.
3. Cooler size and piping pressure drops.

Current thermosyphon systems are using two-pass oil coolers and flow rates based on 3:1 overfeed.

The liquid/vapor returned from the cooler is separated in the receiver. The vapor is vented to the condenser inlet and need only be reliquified since it is still at condenser pressure. See Figure 2.

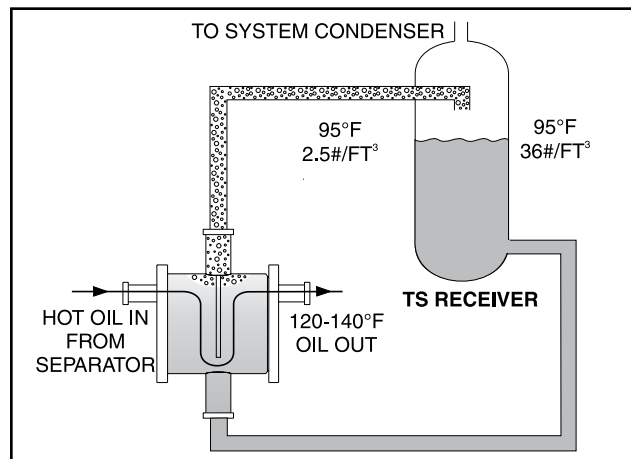

Figure 2

OIL TEMPERATURE CONTROL - Oil temperature will generally run about 15 - 35°F above condensing temperature. In many cases, an oil temperature control is not required if condensing temperature is above 65°F as oil temperature can be allowed to float with condenser temperature.

Condensing Temperature: 65°F - 105°F
Oil Temperature: 80°F - 140°F

INSTALLATION - The plate and shell type thermosyphon oil cooler with oil-side piping and a thermostatically controlled mixing valve (if ordered) are factory mounted and piped. The customer must supply and install all piping and equipment located outside of the shaded area on the piping diagram with consideration given to the following:

1. The refrigerant source, thermosyphon or system receiver, should be in close proximity to the unit to minimize piping pressure drop.

2. The liquid level in the refrigerant source must be **6 to 8 feet minimum** above the center of the oil cooler.

3. A safety valve should be installed if refrigerant isolation valves are used for the oil cooler.

The component and piping arrangement shown in Figure 3 is intended only to illustrate the operating principles of thermosyphon oil cooling. Other component layouts may be better suited to a specific installation. Refer to publication E70-900E for additional information on Thermosyphon Oil Cooling.

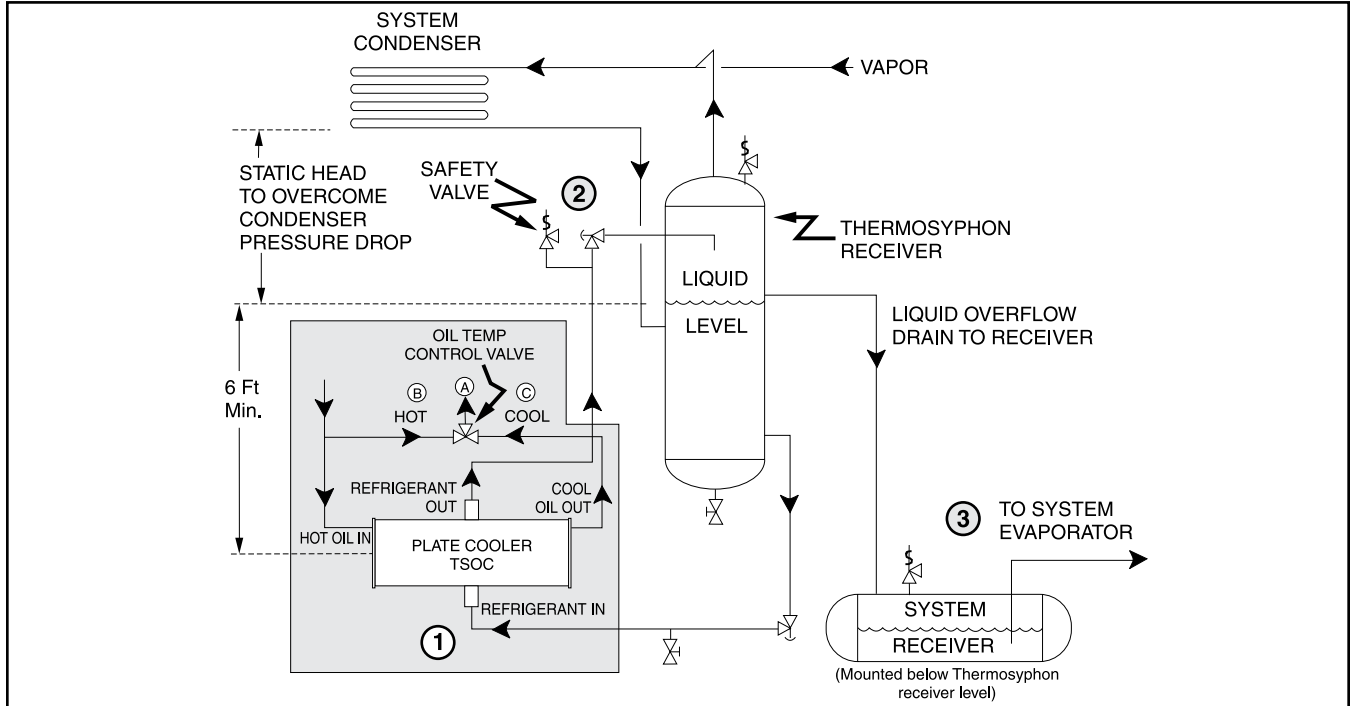

Figure 3

1. The thermosyphon oil cooler is supplied with oil side piped to the compressor unit and stub ends supplied on the refrigerant side.
2. A three-way oil temperature control valve is required where condensing temperature is expected to go below 65°F.
3. A refrigerant-side safety valve is required in this location only when refrigerant isolation valves are installed between the cooler and thermosyphon receiver. If no valves are used between the cooler and TSOC receiver, the safety valve on the TSOC receiver must be sized to handle the volume of both vessels. Then, the safety valve on the cooler vent (liquid refrigerant side) can be eliminated.
4. The system receiver must be below the thermosyphon receiver in this arrangement.

LIQUID INJECTION OIL COOLING (Optional)

The liquid injection system provided on the unit is self-contained but requires the connection of the liquid line sized as shown in the table and careful insertion of the expansion valve bulb into the thermowell provided in the separator. High pressure gas is connected through the regulator to the external port on the liquid injection valve to control oil temperature.

NOTE: For booster applications the high pressure gas connection must be taken from a high side source (high stage compressor discharge). This should be a 3/8" line connected into the solenoid valve provided. This gas is required by the expansion valve external port to control oil temperature.

It is **IMPERATIVE** that an uninterrupted supply of high pressure liquid refrigerant be provided to the injection system at all times. Two items of **EXTREME IMPORTANCE** are the design of the receiver/liquid injection supply and the size of the liquid line.

It is recommended that the receiver be oversized sufficiently to retain a 5-minute supply of refrigerant for oil cooling. The

evaporator supply must be secondary to this consideration. Two methods of accomplishing this are shown.

The dual dip tube method (Figure 4) uses two dip tubes in the receiver. The liquid injection tube is below the evaporator tube to ensure continued oil cooling when the receiver level is low.

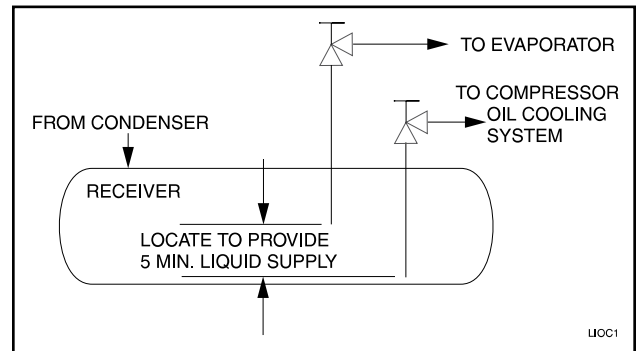

Figure 4

The level-control method (Figure 5) utilizes a float level control on the receiver to close a solenoid valve feeding the evaporator when the liquid falls below that amount necessary for 5 minutes of liquid injection oil cooling.

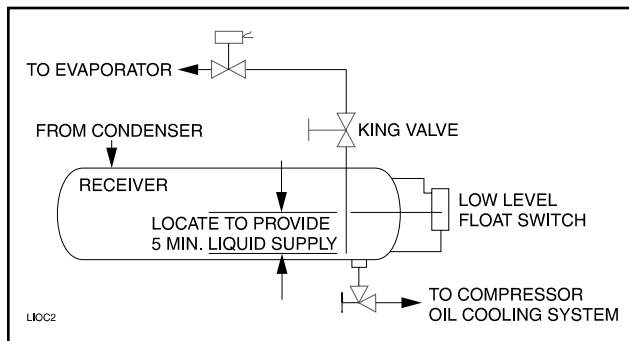

Figure 5

LIQUID LINE SIZES/RECEIVER VOLUME

Liquid line sizes and the additional receiver volume (quantity of refrigerant required for 5 minutes of liquid injection oil cooling) are given in the following table:

LIQUID LINE SIZE and RECEIVER VOLUME

RWF MODEL	LINE SIZE*		POUND PER 5 MIN.	LIQUID VOLUME CU FT
	SCH 80 PIPE	OD TUBING		
R-717 - HIGH STAGE*				
100-134	3/4	—	80	2.0
177-270	1	—	140	4.0
316-480	1-1/4	—	250	7.0
R-717 - BOOSTER*				
100-134	1/2	—	20	0.5
177-270	3/4	—	30	1.0
316-480	1	—	40	1.5

* Based on 100 foot liquid line. For longer runs, increase line size accordingly.

WATER-COOLED OIL COOLING (OPTIONAL)

The plate and shell type water-cooled oil cooler is mounted on the unit complete with all oil piping. The customer must supply adequate water connections and install the two-way water regulating valve if ordered in lieu of a three-way oil temperature valve. It is recommended (local codes permitting) that the water regulator be installed on the water outlet connection. Insert the water regulator valve bulb and well in the chamber provided on the oil outlet connection. Determine the size of the water-cooled oil cooler supplied with the unit, then refer to table for the water connection size. **The water supply must be sufficient to meet the required flow.**

Frick recommends a closed-loop system for the waterside of the oil cooler. Careful attention to water treatment is essential to ensure adequate life of the cooler if cooling tower water is used. **It is imperative that the condition of cooling water and closed-loop fluids be analyzed regularly and as necessary and maintained at a pH of 7.4, but not less than 6.0 for proper heat exchanger life.** After initial start-up of the compressor package, the strainer at the inlet of the oil cooler should be cleaned several times in the first 24 hours of operation.

In some applications, the plate and shell oil cooler may be subjected to severe water conditions, including high temperature and/or hard water conditions. This causes accelerated scaling rates which will penalize the performance of the heat exchanger. A chemical cleaning process will extend the life of the Plate and Shell heat exchanger. It is important to establish regular cleaning schedules.

Cleaning: A 3% solution of Phosphoric or Oxalic Acid is recommended. Other cleaning solutions can be obtained from your local distributor, but they must be suitable for stainless steel. The oil cooler may be cleaned in place by back flushing with recommended solution for approximately 30 minutes. After back flushing, rinse the heat exchanger with fresh water to remove any remaining cleaning solution.

NOTE: The water-regulating valve shipped with the unit will be sized to the specific flow for the unit.

OIL COOLER DATA TABLE

RWF MODEL	TYPICAL COOLER	CONNECTION	
		INLET	OUTLET
100/134 High Stage	116 Plates	3"	3"
100 - 270 Booster	66 Plates	2"	2"
177/222 High Stage	190 Plates	3"	3"
270 High Stage	288 Plates	3"	4"
316/399 Booster	56 Plates	3"	3"
316/399 High Stage	136 Plates	4"	5"
480 Booster	72 Plates	3"	3"
480 High Stage	188 Plates	4"	5"

ECONOMIZER - HIGH STAGE (OPTIONAL)

The economizer option provides an increase in system capacity and efficiency by subcooling liquid from the condenser through a heat exchanger or flash tank before it goes to the evaporator. The subcooling is provided by flashing liquid in the economizer cooler to an intermediate pressure level. The intermediate pressure is provided by a port located part way down the compression process on the screw compressor.

As the screw compressor unloads, the economizer port will drop in pressure level, eventually being fully open to suction. Because of this, an output from the microprocessor is generally used to turn off the supply of flashing liquid on a shell and coil or DX economizer when the capacity falls below approximately 45%-60% capacity (85%-90% slide valve position). This is done because the compressor will be more efficient operating at a higher slide valve position with the economizer turned off, than it will at a low slide valve position with the economizer turned on. Please note however that shell and coil and DX economizers can be used at low compressor capacities in cases where efficiency is not as important as assuring that the liquid supply is subcooled. In such cases, the economizer liquid solenoid can be left open whenever the compressor is running.

Due to the tendency of the port pressure to fall with decreasing compressor capacity, a back-pressure regulator valve (BPR) is generally required on a flash economizer system (FIG. 8) in order to maintain some preset pressure difference between the subcooled liquid in the flash vessel and the evaporators. If the back-pressure regulator valve is not used on a flash economizer, it is possible that no pressure difference will exist to drive liquid from the flash vessel to the evaporators, since the flash vessel pressure will approach suction pressure at a decreased slide valve position. In cases where wide swings in pressure are anticipated in the flash economizer vessel, it may be necessary to add an outlet pressure regulator to the flash vessel outlet to avoid overpressurizing the economizer port, which could result in motor overload. Example: A system feeding liquid to the flash vessel in batches.

The recommended economizer systems are shown below. Notice that in all systems there should be a strainer (STR) and a check valve (VCK) between the economizer vessel and the economizer port on the compressor. The strainer prevents dirt from passing into the compressor and the check valve prevents oil from flowing from the compressor unit to the economizer vessel during shutdown.

CAUTION Other than the isolation valve needed for strainer cleaning, it is essential that the strainer be the last device in the economizer line before the compressor. Also, piston-type check valves are recommended for installation in the economizer line, as opposed to disc-type check valves. The latter are more prone to gas-pulsation-induced failure. The isolation and check valves and strainer should be located as closely as possible to the compressor, preferably within a few feet.

For refrigeration plants employing multiple compressors on a common economizing vessel, regardless of economizer type, each compressor must have a back-pressure regulating valve in order to balance the economizer load, or gas flow, between compressors. The problem of balancing load becomes most important when one or more compressors run at partial load, exposing the economizer port to suction pressure. In the case of a flash vessel, there is no need for the redundancy of a back-pressure regulating valve on the vessel and each of the multiple compressors. Omit the BPR valve on the flash economizer vessel and use one on each compressor, as shown in Figure 9. It is also recommended that the back-pressure regulating valves, used on economizer lines, should be specified with electric shutoff option. The electric shutoff feature is necessary to prevent flow from the common economizer vessel to the suction side of a stopped compressor, through the suction check valve bypass line, if the other compressors and the common economizer vessel are still operating and the HV2 valve on the suction bypass is open.

For refrigeration plants using a Packaged Refrigerant Recirculation (PRR) unit and a direct expansion (DX) economizer system it is necessary to operate the liquid feed solenoid on

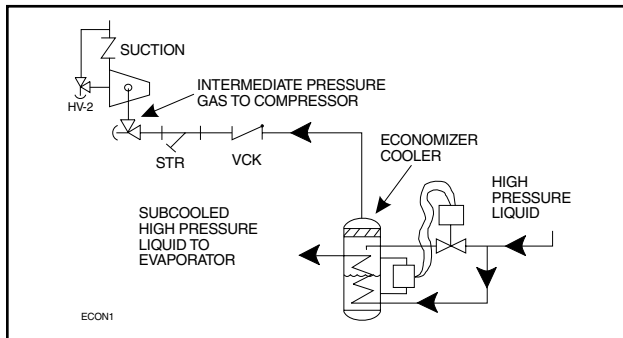

Figure 6 - Shell and Coil Economizer System

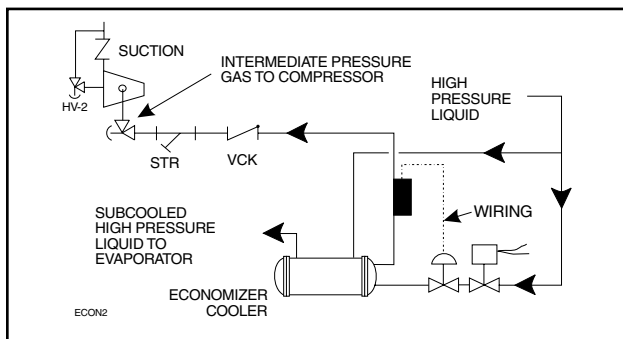

Figure 7 - Direct Expansion Economizer System

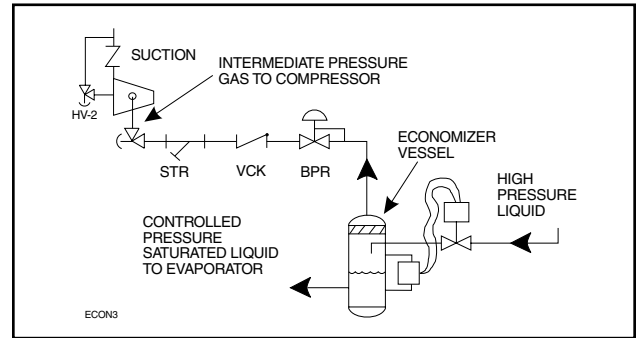

Figure 8- Flash Economizer System

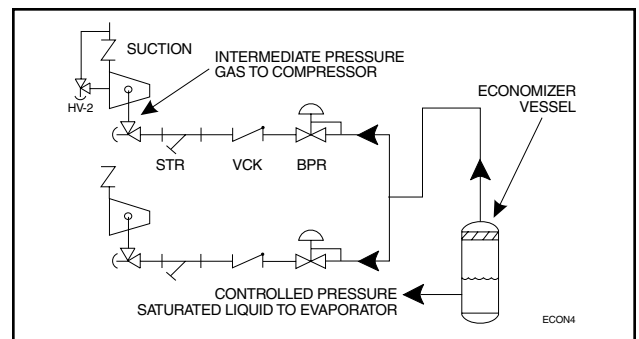

Figure 9 - Multiple Compressor Economizer System

the PRR unit and the liquid feed solenoid on the DX vessel off of a common signal to avoid liquid overfeed on the DX economizer system.

If multiple compressors are operated with a common economizer vessel, it is necessary to install a back-pressure regulator valve with an electric shutoff option in the vapor line piped to the compressor's economizer port. If an electric shutoff is not installed in the economizer vapor line, valve HV-2 must remain closed to avoid a gas bypass from the economizer line through the suction check valve bypass, back to the suction line on a compressor that is shut down.

ECONOMIZER LOAD BALANCING

The most energy efficient manner to operate an economizer system, when using multiple compressors on a common economizer vessel, is to take as much of the flash gas as possible to the compressors that are fully loaded. This can be done in at least two ways.

1. Use the economizer output from the microprocessor to turn off a solenoid, or to actuate the electric shutoff option on a back-pressure regulator, based on percent of slide valve travel. This will direct all the flash vapor to the other loaded compressors.

2. A dual-setpoint back-pressure regulator valve can be used in each of the individual economizer vapor lines. When a compressor is running near full load, the BPR valve will operate on the desired setpoint, or basically wide open, to minimize pressure drop in the line. When one compressor unloads below the slide valve position where the economizer output on the microprocessor turns on, the dual-setpoint feature of the regulator can be actuated by this output to control the pressure, on the vessel side of the regulator, to be a few psi higher. Consequently, the flash gas will be sent to the loaded compressors first, until they can't handle all the vapor and the pressure in the vessel starts to rise. Then, some of the vapor will go to the unloaded compressor to help maintain the vessel at the desired pressure. An example of a back-pressure regulator with electric shutoff and the dual-setpoint feature is an R/S A4ADS.

ELECTRICAL

NOTE: Before proceeding with electrical installation, read the instructions in the section "Proper Installation of Electronic Equipment in an Industrial Environment".

RWF units are supplied with a **QUANTUM™** control system. Care must be taken that the controls are not exposed to physical damage during handling, storage, and installation. The single-box control door must be kept tightly closed to prevent moisture and foreign matter from entry.

NOTE: All customer connections are made in the single-box control mounted on the oil separator. This is the ONLY electrical enclosure and it should be kept tightly closed whenever work is not being done in it.

VOLTAGE PROTECTION

Frick® does not advise nor support the use of UPS power systems in front of the Quantum™ panel. With a UPS power system providing shutdown protection for the Quantum™, the panel may not see the loss of the 3-phase voltage on the motor because the UPS could prevent the motor starter contactor from dropping out. With the starter contactor still energized, the compressor auxiliary will continue to feed an "Okay" signal to the panel. This will allow the motor to be subjected to a fault condition on the 3-phase bus. Some fault scenarios are:

1. The 3-phase bus has power "on" and "off" in a continuous cyclic manner which may cause the motor to overheat due to repeated excessive in-rush currents.
2. Motor cycling may damage the coupling or cause other mechanical damage due to the repeated high torque motor "bumps".
3. Prolonged low voltage may cause the motor to stall and overheat before the motor contactor is manually turned off.

Under normal conditions, the loss of 3-phase power will shut the Quantum™ panel down, and it will restart upon power return. If the panel was in:

- **Auto** – Compressor motor will return to running as programmed.
- **Remote** – The external controller would reinitialize the panel and proceed to run as required.
- **Manual** – The compressor will have to be restarted manually after the 3-phase bus fault has been cleared.

If the local power distribution system is unstable or prone to problems, there are other recommendations to satisfy these problems. If power spikes or low or high line voltages are the problem, then Frick® recommends the use of a Sola® constant voltage (CV) transformer with a line suppression feature. If a phase loss occurs, then you will typically get a high motor amp shutdown. If problems continue to exist, then an examination of the plant's power factor may be in order.

Unless careful design failure analysis is considered in the implementation of power systems, the alternative solutions provide a safer and less expensive implementation. In either case, only one Sola® may be used per compressor. Each compressor needs to be individually isolated from each other through a dedicated control transformer. Sharing a common control power source is an invitation for ground loops and the subsequent unexplainable problems.

MOTOR STARTER PACKAGE



SBC Board damage may occur without timer relay installed in control panel as shown in Starter

Wiring Diagram. All Frick motor starter packages have the timer relay as standard.

Motor starter and interlock wiring requirements are shown in the **Starter Wiring Diagram**. All of the equipment shown is supplied by the installer unless a starter package is purchased separately from Frick. Starter packages should consist of:

1. The compressor motor starter of the specified HP and voltage for the starting method specified (across-the-line, autotransformer, wye-delta, or solid-state).

NOTE: If starting methods other than across-the-line are desired, a motor/compressor torque analysis must be done to ensure that sufficient starting torque is available, particularly in booster applications. Contact FRICK if assistance is required.

2. If specified, the starter package can be supplied as a combination starter with circuit breaker disconnect. However, the motor overcurrent protection/disconnection device can be applied by others, usually as a part of an electrical power distribution board.

3. The oil pump starter with fuses, or in the case where the compressor motor is a different voltage from the oil pump motor, with a circuit breaker disconnect suitable for separate power feed.

4. A 2.0 KVA control power transformer (CPT) to supply 120 volt control power to the microprocessor control system and separator oil heaters is included. If environmental conditions require more than the usual two 500 watt oil heaters, an appropriately oversized control transformer will be required. If frequent power fluctuations are anticipated or extremely noisy power lines are encountered, a regulating control transformer should be considered. Contact FRICK for assistance.

5. For customer-supplied across-the-line starters, a shunting device must be installed across the Current Transformer (terminals 3 & 4).

CAUTION If the shunting device is not installed, the Analog I/O board on the Quantum™ panel may be severely damaged at start-up (see Figure 10).

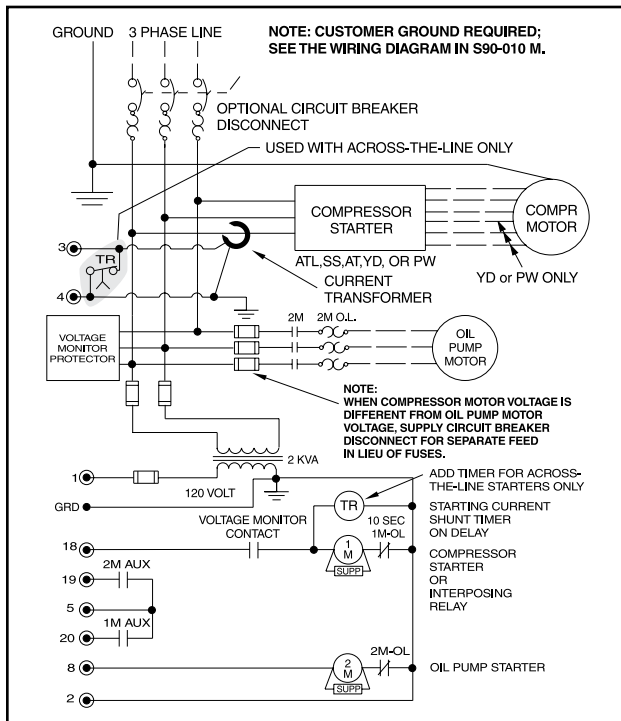

Figure 10 - STARTER WIRING DIAGRAM

6. One each normally open compressor motor and oil pump motor starter auxiliary contact should be supplied. In addition to the compressor and oil pump motor starter coils, the CT and CPT secondaries should be wired as shown on the starter package wiring diagram. The load on the control panel for the compressor motor starter coil should not exceed a Nema size 3 starter. For larger starters, an interposing relay must be used to switch the compressor motor starter coil(s).

NOTE: Do not install a compressor HAND/OFF/AUTO switch in the starter package as this would bypass the compressor safety devices.

7. The compressor motor Current Transformer (CT) is installed on any one phase of the compressor leads.

NOTE: The CT must see all the current of any one phase, therefore in wye-delta applications BOTH leads of any one phase must pass through the CT.

CURRENT TRANSFORMER (CT) RATIOS

The CT ratio for various motor sizes (with a 5 amp secondary) is given in the following table:

HP	VOLTAGE						
	200	230	380	460	575	2300	4160
20	100:5	100:5	50:5	50:5	50:5	-	-
25	100:5	100:5	50:5	50:5	50:5	-	-
30	200:5	100:5	100:5	50:5	50:5	-	-
40	200:5	200:5	100:5	100:5	50:5	-	-
50	200:5	200:5	100:5	100:5	100:5	-	-
60	300:5	200:5	200:5	100:5	100:5	-	-
75	300:5	300:5	200:5	200:5	100:5	-	-
100	400:5	300:5	200:5	200:5	200:5	-	-
125	500:5	400:5	300:5	200:5	200:5	-	-
150	600:5	500:5	300:5	300:5	200:5	-	-
200	800:5	600:5	400:5	300:5	300:5	100:5	50:5
250	800:5	800:5	500:5	400:5	300:5	100:5	50:5
300	1000:5	1000:5	600:5	500:5	400:5	100:5	50:5
350	-	1000:5	800:5	500:5	500:5	100:5	100:5
400	-	-	800:5	600:5	500:5	200:5	100:5
450	-	-	1000:5	800:5	600:5	200:5	100:5
500	-	-	-	1000:5	800:5	600:5	200:5
600	-	-	1200:5	1000:5	800:5	200:5	100:5
700	-	-	-	1200:5	1000:5	200:5	200:5
800	-	-	-	-	1000:5	300:5	200:5
900	-	-	-	-	1200:5	300:5	200:5
1000	-	-	-	-	-	300:5	200:5
1250	-	-	-	-	-	400:5	200:5
1500	-	-	-	-	-	500:5	300:5

MINIMUM BURDEN RATINGS

The following table gives the minimum CT burden ratings. This is a function of the distance between the motor starting package and the compressor unit.

BURDEN RATING		MAXIMUM DISTANCE FROM FRICK PANEL		
ANSI	VA	USING # 14 AWG	USING # 12 AWG	USING # 10 AWG
B-0.1	2.5	15 ft	25 ft	40 ft
B-0.2	5	35 ft	55 ft	88 ft
B-0.5	12.5	93 ft	148 ft	236 ft

CONTROL POWER REGULATOR

Compressor units that will be used in areas that suffer brown-outs and other significant power fluctuations can be supplied with a control power regulator. See Figure 11, Recommended Regulator Installation.

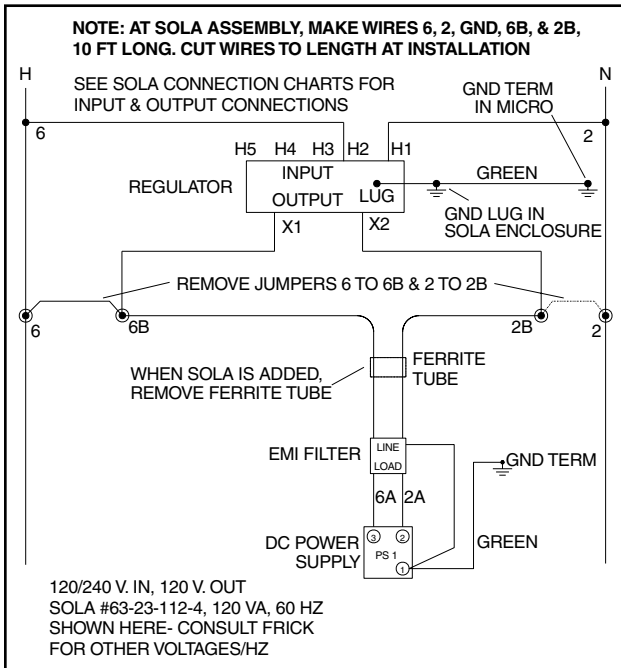

Figure 11 - Recommended Regulator Installation

BATTERY BACKUP

The battery backup is used only for date and time retention during power interruption. All setpoints and other critical information are saved to onboard flash memory.

NOTE: It is not necessary to disconnect the battery backup during extended downtime.

Operation

OPERATION and START-UP INSTRUCTIONS

The Frick RWF Rotary Screw Compressor Unit is an integrated system consisting of seven major subsystems:

1. Control Panel (See publications S90-010 O, M, & CS).
2. Compressor
3. Compressor Lubrication System
4. Compressor Oil Separation System
5. Compressor Hydraulic System
6. Compressor Oil Cooling System
7. Compressor Easy-Start System

The information in this section of the manual provides the logical step-by-step instructions to properly start up and operate the RWF Rotary Screw Compressor Unit.

THE FOLLOWING SUBSECTIONS MUST BE READ AND UNDERSTOOD BEFORE ATTEMPTING TO START OR OPERATE THE UNIT.

SGC COMPRESSOR

The Frick RWF rotary screw compressor utilizes mating asymmetrical profile helical rotors to provide a continuous flow of refrigerant vapor and is designed for both high-pressure and low-pressure applications. The compressor incorporates the following features:

1. High capacity roller bearings to carry radial loads at both the inlet and outlet ends of the compressor.
2. Heavy-duty, four-point angular contact ball bearings to carry axial loads are mounted at the discharge end of compressor.
3. Balance pistons located in the inlet end of the compressor to reduce axial loads on the axial load bearings and increase bearing life.
4. Moveable slide valve to provide fully modulating capacity control from 100% to approximately 10% of full load capacity.
5. VOLUMIZER® volume ratio control to allow infinitely variable volume ratio from 2.2 to 5.0 during compressor operation for all models.
6. A hydraulic unloader cylinder to operate the slide stop and slide valve.
7. Bearing and casing design for 350 PSI discharge pressure. **This PSI rating applies only to the compressor and does not reflect the design pressure of the various system components.**
8. All bearing and control oil vented to closed thread in the compressor instead of suction port to avoid performance penalties from superheating suction gas.
9. Shaft seal design to maintain operating pressure on seal well below discharge pressure, for increased seal life.
10. Oil injected into the rotors to maintain good volumetric and adiabatic efficiency even at very high compression ratios.

11. Shaft rotation clockwise facing compressor, suitable for all types of drives. **SEE FOLLOWING CAUTION.**



CAUTION Compressor rotation is clockwise when facing the compressor drive shaft. (See Figure 12) The compressor should never be operated in reverse rotation as bearing damage will result.

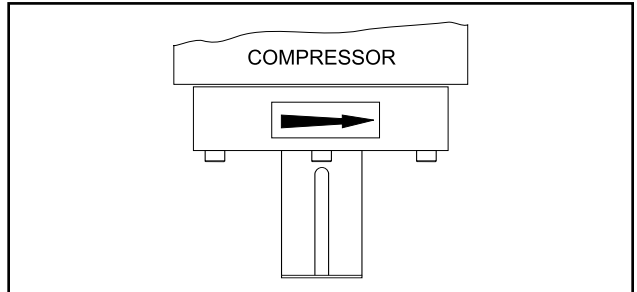

Figure 12

12. Dual compressor casing design for very low airborne noise transmission.
13. Suction flange is 300 psig ANSI type.
14. Integral suction strainer is provided.
15. "D" Flange adapter for bolting directly to motor.

COMPRESSOR LUBRICATION SYSTEM

The lubrication system on an RWF screw compressor unit performs several functions:

1. Provides lubrication to bearings and seal.
2. Provides a cushion between the rotors to minimize noise and vibrations.
3. Helps keep the compressor cool and prevents overheating.
4. Provides an oil supply to hydraulically actuate the slide valve and slide stop.
5. Provides oil pressure to the balance pistons to help increase bearing life.
6. Provides an oil seal between the rotors to prevent rotor contact or gas bypassing.

The compressor unit may be equipped with either a no pump or a demand pump lubrication system. Additionally, either system may contain dual oil filters and liquid injection, water-cooled, or thermosyphon oil cooler for compressor oil cooling.

NO PUMP OIL SYSTEM

The RWF screw compressor unit is designed to be self-lubricating. Oil being supplied to the compressor from the oil separator is at system head pressure. Within the compressor, oil porting to all parts of the compressor is vented back to a point in the compressor's body that is at a pressure lower than compressor discharge pressure. The compressor's normal operation makes the compressor unit operate essentially as its own oil pump. All oil entering the compressor is moved by the compressor rotors out the compressor outlet and back to the oil separator.

For normal high-stage operation an oil pump is not required.

COLD-START SYSTEM

The RWF package is equipped with a special "cold start" discharge check valve (see Figure 13) on the gas outlet connection of the oil separator. This valve causes the oil separator to develop oil pressure rapidly on initial start in order to lubricate the compressor without requiring an oil pump, even in cold ambient temperatures with all pressures equalized.

For high-stage packages, the cold-start valve is equipped with a large spring that creates 30 psi of pressure in the oil separator (above suction pressure), for lubrication of the compressor.

WARNING DO NOT ATTEMPT TO SERVICE THE YORK REFRIGERATION/GRAM COLD START VALVE. PLEASE CONTACT THE FRICK SERVICE DEPARTMENT.

Once the compressor is running it will begin to force gas to the condenser at connection P2. As the condenser heats up it will begin to rise in pressure as the compressor suction pulls down in pressure. As soon as differential pressure is developed between the condenser and suction, these pressures act across a piston inside the cold-start valve to partially overcome the spring force. When the differential pressure reaches and exceeds 30 psi, the piston fully overcomes the spring force and powers the valve fully open for very low operating pressure drop.

For booster applications, the valve is equipped with a lighter spring which produces 15 psi oil pressure above suction pressure before it fully powers open.

The RWF package is also equipped with a suction check valve bypass. The oil separator will slowly bleed down to system suction pressure when the unit is stopped. This allows the compressor drive motor to have an easier start, and the discharge check valve will seat more tightly. See the "SUCTION CHECK VALVE BYPASS" section for operation.

NOTE: For alarm descriptions and shutdown or cutout parameters, see publication S90-010 O.

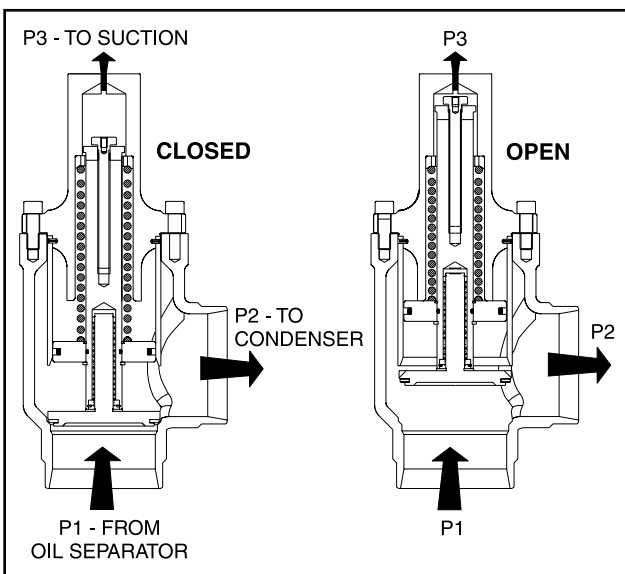

Figure 13 - Cold Start Valve

DEMAND PUMP OIL SYSTEM

This system is designed to provide adequate compressor lubrication for some high stage applications that operate with low differential pressure across the compressor suction and discharge and all booster applications.

During the period from start-up to normal operation the oil pressure alarm and oil pressure cutout setpoints will vary according to formulas built into the microprocessor control program.

NOTE: For alarm descriptions and shutdown or cutout parameters, see publication S90-010 O.

COMPRESSOR OIL SEPARATION SYSTEM

The RWF is an oil flooded screw compressor. Most of the oil discharged by the compressor separates from the gas flow in the oil charge reservoir. Some oil, however, is discharged as a mist which does not separate readily from the gas flow and is carried past the oil charge reservoir. One or more coalescer filter elements then COALESCE the oil mist into droplets which fall to the bottom of the coalescer section of the oil separator (see Figure 14). The return of this oil to the compressor is controlled by a throttling valve on both high stage and booster applications.

NOTE: Open throttling valve only enough to keep coalescer end of separator free of oil.

The sight glass located near the bottom of the coalescer section of the oil separator should remain empty during normal operation. If an oil level develops and remains in the sight glass, a problem in the oil return separation system or compressor operation has developed. Refer to MAINTENANCE for information on how to correct the problem.

NOTE: The normal charging level is midway in the top sight glass located midway along the oil separator shell.

OIL SEPARATION SYSTEMS

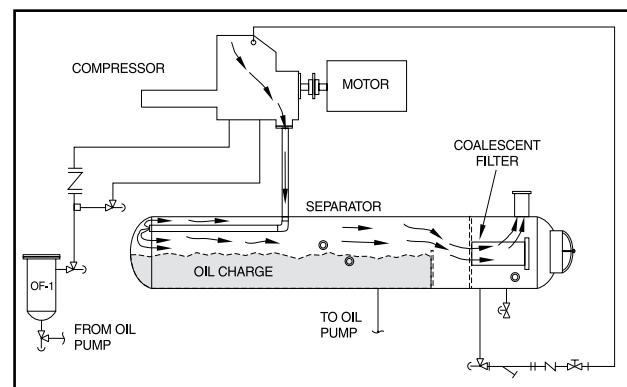

Figure 14

COMPRESSOR HYDRAULIC SYSTEM

The compressor hydraulic system moves the movable slide valve (MSV) to load and unload the compressor. It also moves the movable slide stop (MSS) to increase or decrease the compressor's volume ratio (V_i).

The hydraulic cylinder located at the inlet end of the SGC compressor serves a dual purpose. It is separated by a fixed bulkhead into two sections. The movable slide valve (MSV) section is to the left of the bulkhead and the movable slide stop (MSS) to the right. Both sections are considered double-acting hydraulic cylinders as oil pressure moves the pistons in either direction.

Both sections are controlled by double-acting, four-way solenoid valves which are actuated when a signal from the appropriate microprocessor output energizes the solenoid valve.

SINGLE-ACTING MODE - High Stage

Close valve at SC2
Open valve at BP (bypass)

High stage compressor loading: The compressor loads when MSV solenoid YY2 is energized and oil flows from the unload side of the cylinder out port SC1, through valve ports A and T to compressor suction. Simultaneously, discharge pressure loads the slide valve.

High stage compressor unloading: The compressor unloads when MSV solenoid YY1 is energized and oil flows from the oil manifold through valve ports P and A to cylinder port SC1 and enters the unload side of the cylinder. Simultaneously, gas on the load side of the cylinder is vented through port SC2 and valve BP to compressor suction.

NOTE: To control the rate of loading and unloading, throttle the needle valve at SC1 port.

DOUBLE-ACTING MODE - Booster

Open valve at SC2
Close valve at BP (bypass)

Booster Compressor Loading: The compressor loads when MSV solenoid YY2 is energized and oil flows from the oil manifold through valve ports P and B to cylinder port SC2 and enters the load side of the cylinder. Simultaneously, oil contained in the unload side of the cylinder flows out cylinder port SC1 through valve ports A and T to compressor suction.

Booster Compressor Unloading: The compressor unloads when MSV solenoid YY1 is energized and oil flows from the oil manifold through valve ports P and A to cylinder port SC1 and enters the unload side of the cylinder. Simultaneously, oil contained in the load side of the cylinder flows out of compressor port SC2 through valve ports B and T to compressor suction.

NOTE: To control the rate of loading and unloading, throttle valves SC1 and SC2.

NOTE: To slow all valve movements - loading, unloading, and V_i change - throttle valve 2.



NEVER open valve BP and valve SC2 at the same time during compressor operation.

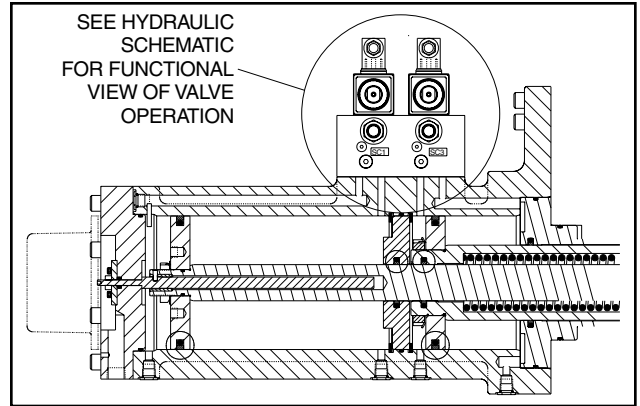

Figure 15

VOLUMIZER VOLUME RATIO CONTROL

Open valve at SC3
Open valve at SC4

Compressor V_i increase: The volume ratio V_i is increased when MSS solenoid valve YY3 is energized and oil flows from the oil manifold through valve ports P and A to compressor port SC3, enters the increase side of the cylinder and overcomes the decrease spring tension. Simultaneously, oil flows from SC4 port through valve ports B and T to compressor suction.

Compressor V_i decrease: The volume ratio V_i is decreased when MSS solenoid valve YY4 is energized and oil flows from the oil manifold through valve ports P and B to compressor port SC4, enters the decrease side of the cylinder. Simultaneously, oil flows from SC3 port through valve ports A and T to compressor suction.

TO CONTROL THE RATE OF V_i CHANGE, THROTTLE THE NEEDLE VALVE AT SC3 PORT.

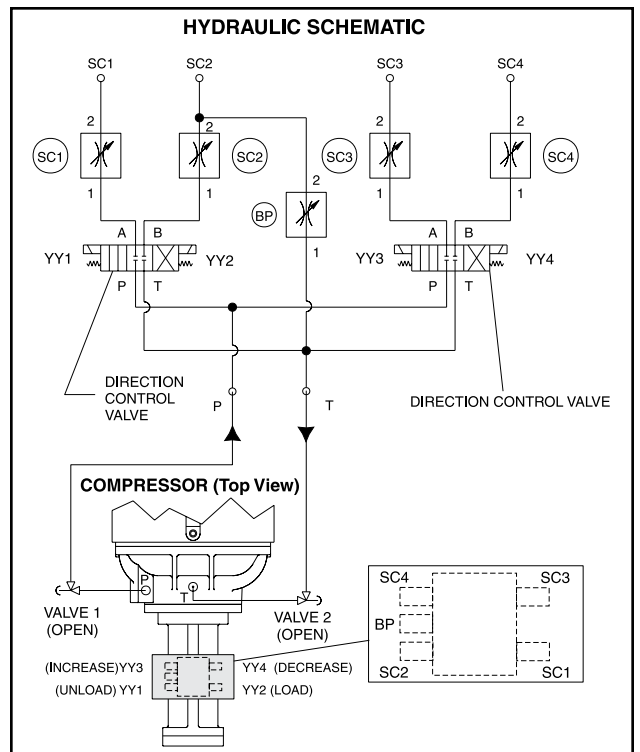

Figure 16

COMPRESSOR OIL COOLING SYSTEMS

The RWF unit can be equipped with one of several systems for controlling the compressor oil temperature. They are single or dual-port liquid injection and thermosyphon or water-cooled oil coolers. Each system is automatically controlled, independent of compressor loading or unloading.

Oil cooling systems should maintain oil temperature within the following ranges for R-717:

Liquid Injection Oil Cooling	External* Oil Cooling
130 - 170°F	120 - 160°F

* Thermosyphon oil cooling (TSOC) or Water cooled oil cooling (WCOC).

SINGLE-PORT LIQUID INJECTION

The single-port liquid injection system is designed to permit liquid refrigerant injection into one port on the compressor at any given moment and operates as outlined.

Solenoid valve YY5 is energized by the microprocessor when the temperature sensor, installed in the oil manifold, exceeds the LICO set point. High-pressure liquid refrigerant is then supplied to the temperature control valve (TCV). The temperature control valve is equalized to a constant back pressure by the differential pressure control valve (PDCV). The differential pressure control valve uses discharge gas to maintain downstream pressure. The gas downstream of the differential pressure control valve is bled off to the compressor suction to ensure steady and constant operation of the valve. **Refer to P & I DIAGRAMS section for piping and instrumentation drawings.**

BOOSTER OR SWING DUTY APPLICATION

Discharge gas from the high-stage compressor is required to assist the differential pressure control valve (PDCV) in providing the temperature control valve (TCV) with a constant back pressure.

A solenoid valve YY6 is installed before the differential pressure control valve (PDCV) to prevent migration of high pressure gas during shutdown. A Frick-installed timer limits the high pressure gas to only thirty seconds duration, since intermediate gas pressure and spring tension are sufficient to maintain closure on unit shutdown. A metering valve is also provided for use as a service valve and to allow discharge gas flow regulation to prevent excessive force and resulting closure "hammering".

A field-installed 1/4 inch OD tubing connection is required between the high stage compressor discharge piping line (or receiver) and the check valve. **Refer to P & I DIAGRAMS section for piping and instrumentation drawings.**

NOTE: An oil pump may be required for booster or swing duty applications.

DUAL-PORT LIQUID INJECTION

The dual-port liquid injection system is designed to obtain the most efficient compressor performance at high and low compression ratios by permitting injection of liquid refrigerant into one of two ports optimally located on the compressor. This minimizes the performance penalty incurred with liquid injection oil cooling.

The dual-port system contains all the components of the single-port system with the addition of a double acting solenoid valve YY7 and operates as outlined.

Solenoid valve YY5 is energized by the microprocessor when the temperature sensor, installed in the oil manifold, exceeds the LICO set point. Liquid refrigerant is then passed through the temperature control valve (TCV) to the double-acting solenoid valve YY7. Depending on the compressor's operating volume ratio (V_i), the microprocessor will select the flow of the liquid refrigerant to either compressor port SL-1 or SL-2, whichever is more efficient.

When the compressor operates BELOW $3.5 V_i$, compressor port SL-1 supplies the liquid cooling. When the (V_i) rises ABOVE $3.5 V_i$, port SL-2 supplies the liquid cooling.

The temperature control valve is equalized to a constant back pressure by the differential pressure control valve (PDCV).

Both the differential pressure control valve (PDCV) and the double-acting solenoid valve YY7 use discharge gas to maintain downstream pressure. The gas downstream of both valves is bled off to the compressor suction to ensure steady and constant operation of the valves. **Refer to P & I DIAGRAMS section for piping and instrumentation drawings.**

LIQUID INJECTION ADJUSTMENT PROCEDURE

Adjustments must be made to ensure the oil is at the proper temperature. When the adjustments have been made correctly, the oil temperature, the discharge temperature and the temperature of the oil in the separator should all be approximately the same. (Refer to P&I Diagram)

Carefully insert The bulb from the thermal expansion valve (TXV) into the well in the discharge pipe between the compressor and the oil separator. Then open the valve to the oil separator high pressure connection.

Next, open the refrigerant supply valve, remove the cap on the pressure regulating valve (PCV), and close the adjusting valve.

For low temperature oil – 125° to 135°F

After the unit has been started, wait for the oil temperature to reach 122°F. This is the preprogrammed temperature to open the liquid feed solenoid in the liquid injection supply line.

Open the adjusting valve only until the needle on the gauge begins to move a very small amount.

Next, adjust the pressure regulating valve to approximately 80 psig by turning the adjustment ring inside the top of the valve with a 5/16" Allen wrench. Turn the wrench clockwise to raise the oil temperature, and counterclockwise to lower the oil temperature.

After the adjustments have been made, wait until the oil and discharge temperatures have had a chance to stabilize before readjusting. The end result should be between 135° and 140°F.

For high temperature oil – 160° to 170°F

After the unit has been started, wait for the oil temperature to reach 122°F. This is the preprogrammed temperature to open the liquid feed solenoid in the liquid injection supply line.

Open the adjusting valve only until the needle on the gauge begins to move a very small amount.

Next, adjust the pressure regulating valve to approximately 30 psig by turning the adjustment ring inside the top of the valve with a 5/16" Allen wrench. Turn the wrench clockwise to raise the oil temperature, and counter-clockwise to lower the oil temperature. After the adjustment has been made, wait until the oil and discharge temperatures have had a chance to stabilize before readjusting. The end result should be between 160° and 170°F.

Liquid Injection Oil Cooling - Ammonia

To tell if the unit you are starting has a low or high temperature liquid injection valve, look at the power head of the Thermal Expansion Valve.

If the unit is using Ammonia as a refrigerant and is for low temperature the Sporlan number on the power head should be Y764 or Y830. Set the oil temperature for 135°F.

If the unit is using Ammonia as a refrigerant and is for high temperature the Sporlan number on the power head should be Y1199 or Y1201. Set the oil temperature for 160°F.

Liquid Injection Oil Cooling - Halocarbon

To tell if the unit you are starting has a low or high temperature liquid injection valve, look at the power head of the Thermal Expansion Valve.

If the unit is using Halocarbon as a refrigerant and is for low temperature, the Sporlan number on the power head should be L3. Set the oil temperature for 135°F.

If the unit is using Halocarbon as a refrigerant and is for high temperature, the Sporlan number on the power head should be Y1200 or Y1202. Set the oil temperature for 160°F.

When the unit has high temperature liquid injection oil cooling, set the oil temperature alarm for 170°F.

Set the oil temperature cutout for 180°F.

When the unit has low temperature liquid injection oil cooling, set the oil temperature alarm and cutout at the default values set in the microprocessor.

**EZ-COOL™ LIQUID INJECTION
ADJUSTMENT PROCEDURE**

Use the following steps in setting up the EZ-Cool™ LIOC using the Quantum Panel PID loop from analog output channel one and the HMMR motorized valve.

- Ensure that a driver chip is in chip slot U-7 on analog board one.
- Ensure that a D/A converter chip is in chip slot U-15 on analog board one.
- Ensure that a jumper is between pins 2&3 on J-26 and pins 1&2 on J-39 of analog board one.
- Ensure that the software version on the analog board one e-prom is version 1.04 or higher. This chip is in slot U-13 and has a label calling out the version. If the label is missing press **[Menu] > [About]**, the version should appear in the lower left corner of the screen.
- Ensure that the HMMR valve is wired to the Quantum control panel per drawing 649B0898.
- Set the High Oil Temperature alarm and shutdown setpoints to 165° and 170°F for ammonia or 170° and 175°F for R134A and R507 respectively.
- Once this is done press **[Menu] > [Calibration] > [OK] > [More] > [Analog Out Calibration]**.
- Press **[Calibration Setpoints]** and enter a [2] for **Input Channel to Output** for analog output 1 > **[Enter] > [OK]**. The screen should appear as shown in Figure 17.

Analog Output Setup				Thu 7 Mar 2002 23:16:43
	Input Channel to Output	Input	Output	Calibration Setpoints
Analog Output 1	<input type="text" value="2"/>	196.4 F	58.8 %	Analog 1 Setpoints Calibration
Analog Output 2	<input type="text" value="1"/>	196.4 F	58.8 %	Analog 2 Setpoints Calibration
Analog Output 3	<input type="text" value="14"/>	13.6 %	13.6 %	Analog 3 Out Calibration
Analog Output 5	<input type="text" value="21"/>	72.9 PSIG	17.5 %	Analog 5 Out Calibration
Analog Output 6	<input type="text" value="21"/>	72.9 PSIG	17.5 %	Analog 6 Out Calibration

Figure 17

- The **Output** should be reading 0% with the machine off line.
- With the machine off line press **[Menu]** > **[Calibration]** > **[OK]** > **[More]** > **[Analog Out Calibration]** > **[Analog 1 Calibration]**. **Analog Output 1** should read 0%, the **Top End Value** 100%, **Bottom End Value** 0% and the **Offset Value** 0%.
- If the actual output signal is more than 20mA at 100% output follow the instructions at the bottom of this screen to correct the top end value setpoint.
- Regarding adjustment, the goal is to increase or decrease the proportional gain setpoint until the discharge temperature holds within or close to the dead band, with minimal fluctuation of the output signal.

SUCTION CHECK VALVE BYPASS

The RWF unit is equipped with a low-pressure-drop suction check valve bolted directly to the compressor housing. Units that have an 8" stop valve or larger will be piped as shown in the shaded area of the illustration below. During normal operation, valve HV-1 is closed. This is a pump-out connection to allow refrigerant removal to the system suction prior to evacuation for servicing. Valve HV-2 must be open in most systems at all times. It should normally be cracked open to allow the oil separator to slowly bleed down to system suction pressure when the unit is stopped (having this valve cracked open allows the compressor drive motor to have an easier start, and the discharge check valve will seat more tightly). If the drive coupling backspins, start closing the valve until the backspin stops. If the separator oil level foams excessively on shutdown, HV-2 should be closed slightly. If the separator takes more than 20 – 30 minutes to equalize to suction pressure after shutdown, HV-2 can be opened slightly. See Figure 20.

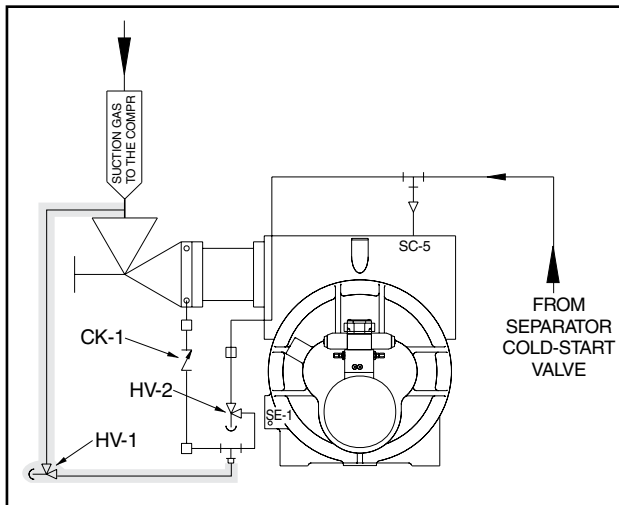

Figure 20

Check valve CK-1 is installed on all RWF packages with suction pressure below atmospheric or when installed with economizer option utilized on multiple compressor plants.

On high-stage systems, check valve CK-1 should be installed with a 40 psi spring to avoid the possibility of back-feeding to a shut-down compressor from a common economizer vessel.

On booster systems, check valve CK-1 should be installed with a 15 psi spring to avoid the possibility of air ingress into the system, if the system suction pressure is below atmospheric.

HV-2 should be closed, on systems that utilize autocycle to restart the compressor, based on increase in system suction pressure during shutdown, **IF** slowly bleeding the oil separator gas to suction will raise the suction pressure enough to cause short cycling of the compressor.

Also, it is important to close HV-2, if the oil pump is to be run for long periods of time with the compressor stopped, to avoid oil being pumped up the suction line.

LOW AMBIENT OPERATION

It is recommended that oil separators be insulated as a minimum requirement to preserve the heat generated by the oil heaters. It is important that the coalescer end of the separator be insulated to prevent refrigerant condensation.

On systems located outdoors or in unheated buildings where the ambient temperature could drop below +40°F, insulating and/or heat tracing of the compressor lube oil systems is highly recommended.

When low ambient temperatures (below +20°F) are a possibility, it is recommended that lube oil lines, oil filters, oil pumps, and oil coolers be heat traced and insulated.

Freeze-up protection must also be provided for all water-cooled equipment

INITIAL START-UP

Initial start-up must be performed under the supervision of a FRICK authorized start-up representative to prevent voiding the compressor warranty. Prior to the start-up, the prestart check must be accomplished.

INITIAL START-UP PROCEDURE

Having performed the checkpoints on the prestart check list the compressor unit is ready for start-up. It is important that an adequate refrigerant load be available to load test the unit at normal operating conditions. The following points should be kept in mind during initial start-up.

1. It is imperative that during the initial start-up of the package that the hand expansion valve on the main oil injection line is fully open to ensure adequate oil flow. There is still an orifice installed in the compressor to control maximum oil flow. At initial start-up of the package the hand expansion valve must be fully open. After initial start-up of the package the hand expansion valve should be adjusted. There are two methods of determining the correct adjustment of this valve.

The best method to determine target discharge temperature is to run CoolWare™. Run CoolWare™ or ScrewSelect™ with the operating conditions of the compressor. The program will give you a theoretical discharge temperature of the compressor. Once this temperature is known, you may adjust the hand expansion valve. The ideal discharge temperature is within 5°F + or – of the theoretical discharge temperature. Adjust the valve to achieve the theoretical discharge temperature. If you do not have access to CoolWare™ or ScrewSelect™, 180°F is a good target discharge temperature for a high stage ammonia compressor. Booster applications and compressors using HFC and HCFC refrigerants may run cooler. Compressors with high discharge pressure may run hotter.

The first method is used for compressors with External Oil Cooling (Thermosyphon, Water Cooled, and Glycol Cooled). Before the initial startup of the compressor close the hand expansion valve completely. Open the valve back up and count the turns that it takes to fully open the valve. After the initial startup close the valve to achieve approximately 180° F discharge temperature or the theoretical temperature from CoolWare. Do not fully close the valve at any time while the compressor is running.

The second method is used for compressors with Liquid Injection Oil Cooling. Because the discharge temperature is controlled by the Liquid Injection Thermal Expansion Valve you will not be able adjust for the correct oil flow by using the discharge temperature. Before the initial startup of the compressor close the hand expansion valve completely. Open the valve back up and count the turns that it takes to fully open the valve. After the initial startup close the valve ½ way. If it took 10 turns to open the valve completely, then turn it in 5 turns. If it took 7 turns to open, then close the valve 3½ turns. Do not close the valve any further than ½ the number of turns required to fully open it.



Failure to properly adjust this valve can lead to excessive noise and vibration of the compressor and package, premature failure of the bearings, liquid loading of the rotors, liquid starvation of the rotors and catastrophic failure of the compressor.

2. For proper and safe operation, the compressor must be run at the proper speed and discharge pressure. Exceeding design conditions creates a potential hazard.

3. Rotate and lubricate motor bearings according to manufacturer's recommendations **PRIOR** to initial start-up as required.

4. After running the unit for approximately three hours, adjust liquid injection oil cooling if applicable. If unit has water-cooled oil cooling, adjust water control valve to cooler.

5. The compressor slide valve and slide stop linear transmitters should be calibrated.

6. Perform vibration analysis if equipment is available.

NORMAL START-UP PROCEDURE

1. Confirm system conditions permit starting the compressor.

2. Press the **[RUN]** key.

3. Allow the compressor to start-up and stabilize. Press the **[AUTO]** key immediately below the V ratio label on the operating display screen. Press the **[AUTO]** key immediately below the SV POS label on the operating display. The compressor is now operating in the automatic mode.

4. Observe the compressor unit for mechanical tightness of the external piping, bolts and valves. Ensure that the machine is clean from oil and refrigerant leaks. If any of these occur, shut down the compressor and correct the problem as necessary using good safety precautions.

5. **RETIGHTEN MANWAY BOLTS** at condenser design pressure (while system is running).

RESTARTING COMPRESSOR UNIT AFTER CONTROL POWER INTERRUPTION (PLANT POWER FAILURE)

1. Check variable setpoints.

2. Follow normal start-up procedure.

Maintenance

GENERAL INFORMATION

This section provides instructions for normal maintenance, a recommended maintenance program, troubleshooting and correction guides, and typical P and I diagrams. For typical wiring diagrams and information about the *Quantum™* control panel, consult publication S90-010 M.



THIS SECTION MUST BE READ AND UNDERSTOOD BEFORE ATTEMPTING TO PERFORM ANY MAINTENANCE OR SERVICE TO THE UNIT.

NORMAL MAINTENANCE OPERATIONS

When performing maintenance you must take several precautions to ensure your safety:

GENERAL MAINTENANCE

Proper maintenance is important in order to assure long and trouble-free service from your screw compressor unit. Some areas critical to good compressor operation are:

1. Keep refrigerant and oil clean and dry, avoid moisture contamination. After servicing any portion of the refrigeration system, evacuate to remove moisture before returning to service. Water vapor condensing in the compressor while running, or more likely while shut down, can cause rusting of critical components and reduce life.
 2. Keep suction strainer clean. Check periodically, particularly on new systems where welding slag or pipe scale could find its way to the compressor suction. Excessive dirt in the suction strainer could cause it to collapse, dumping particles into the compressor.
 3. Keep oil filters clean. If filters show increasing pressure drop, indicating dirt or water, stop the compressor and change filters. Running a compressor for long periods with high filter pressure drop can starve the compressor for oil and lead to premature bearing failure.
 4. Avoid slugging compressor with liquid refrigerant. While screw compressors are probably the most tolerant to ingestion of some refrigerant liquid of any compressor type available today, they are not liquid pumps. Make certain to maintain adequate superheat and properly size suction accumulators to avoid dumping liquid refrigerant into compressor suction.
- Keep liquid injection valves properly adjusted and in good condition to avoid flooding compressor with liquid. Liquid can cause a reduction in compressor life and in extreme cases can cause complete failure.
5. Protect the compressor during long periods of shut down. If the compressor will be sitting for long periods without running it is advisable to evacuate to low pressure and charge with dry nitrogen or oil. This is particularly true on systems known to contain water vapor.
 6. Preventive maintenance inspection is recommended any time a compressor exhibits a noticeable change in vibration level, noise or performance.



1. IF UNIT IS RUNNING, PRESS [STOP] KEY.
2. DISCONNECT POWER FROM UNIT BEFORE PERFORMING ANY MAINTENANCE.
3. WEAR PROPER SAFETY EQUIPMENT WHEN COMPRESSOR UNIT IS OPENED TO ATMOSPHERE.
4. ENSURE ADEQUATE VENTILATION.
5. TAKE NECESSARY SAFETY PRECAUTIONS REQUIRED FOR THE REFRIGERANT BEING USED.



CLOSE ALL COMPRESSOR PACKAGE ISOLATION VALVES PRIOR TO SERVICING THE UNIT. FAILURE TO DO SO MAY RESULT IN SERIOUS INJURY.

COMPRESSOR SHUTDOWN and START-UP

For seasonal or prolonged shutdowns the following procedure should be followed:

1. Reduce the system pressure to the desired condition.
2. Press [STOP] key to cease operation of the compressor.
3. Open disconnect switches for compressor motor and oil pump starters.
4. Turn on oil heater circuit breaker.
5. Close suction and discharge service valves, also liquid injection and economizer service valves, if applicable. **Attach CLOSED TAGS.**
6. Shut off cooling water supply valve to oil cooler, if applicable. **Attach CLOSED TAG.**
7. Protect oil cooler from ambient temperatures below freezing or remove water heads.

To start-up after a seasonal or prolonged shutdown the following procedure should be followed:

1. Any water necessary for the operation of the system that may have been drained or shut off should be restored and turned on.
2. Open suction and discharge service valves, also liquid injection and economizer service valves, if applicable. Remove tags.
3. Close disconnect switches for compressor, motor and oil pump starters.
4. Turn off oil heater circuit breaker.
5. Perform checkpoints on prestart check list, then start unit.

GENERAL INSTRUCTIONS FOR REPLACING COMPRESSOR UNIT COMPONENTS

NOTE: See Publication S70-660 SM for procedures covering replacement motor and compressor mounting.

When replacing or repairing components which are exposed to refrigerant pressure proceed as follows:

1. Push **[STOP]** key on control panel to shut down unit.
2. Open disconnect switches for compressor and pump motor starters.
3. Close suction and discharge service valves, also liquid injection and economizer service valves, if applicable.
4. **SLOWLY** vent separator to low-side system pressure using the bypass line on the suction trap. **NOTE: Recover or transfer all refrigerant vapor, in accordance with local ordinances, before opening to atmosphere.** The separator **MUST** be equalized to atmospheric pressure.
5. Make replacement or repair.
6. Isolate the low pressure transducer, PE-4, to prevent damage during pressurization and leak test.
7. Pressurize unit and leak test.
8. Evacuate unit.
9. Open suction and discharge service valves, low pressure transducer, and also liquid injection and economizer service valves, if applicable.
10. Close disconnect switches for compressor and oil pump motor starters.
11. Unit is ready to put into operation.
12. Perform checkpoints on prestart checklist, then start unit.



Oil-entrained refrigerant may vaporize, causing a separator pressure increase. Repeat venting and recovery procedure, if necessary.



DO NOT MIX OILS of different brands, manufacturers, or types. Mixing of oils may cause excessive oil foaming, nuisance oil level cutouts, oil pressure loss, gas or oil leakage and catastrophic compressor failure.



Use of filter elements other than Frick may cause warranty claim may to be denied.

Replace the gasket and reinstall the canister cover. Torque cover bolts first to finger tight, then 65 ft-lb, then 130 ft-lb.

7. Close purge valve.
8. Open outlet service valve and leak test.
9. Filter is ready to place in service.

STRAINER - DEMAND OIL PUMP

To clean the demand oil pump strainer, the unit must be shut down. The procedure is as follows:

1. Push **[STOP]** key on microprocessor panel to shutdown unit, then open disconnect switches for compressor and oil pump motor starters.
2. Close strainer inlet service valve.
3. Open drain valve located in the strainer cover and drain oil into a container.
4. Remove capscrews securing strainer cover, strainer cover, gasket and element. Retain gasket.
5. Wash element in solvent and blow clean with air.
6. Wipe strainer body cavity clean with a lint free clean cloth.
7. Replace cleaned element, gasket and reattach cover using retained capscrews.
8. Close drain valve and open strainer inlet service valve.
9. Check for leakage.
10. Close disconnect switches for compressor and oil pump motor starters.
11. Start unit.



Use of filter elements other than Frick may cause warranty claim may to be denied.

The procedure to change filter cartridge(s) is as follows:

1. If a single oil filter is installed, push **[STOP]** key on microprocessor panel to shut down unit, then open disconnect switches for compressor and oil pump motor starters.

If dual oil filters are installed, open the outlet, then inlet service valves of the standby filter.



Open inlet service valve slowly to prevent a sudden pressure drop which could cause an oil filter differential alarm.

2. Close outlet then inlet service valves of filter being serviced.

STRAINER - LIQUID INJECTION

To clean the liquid injection strainer the unit must be shut down. The procedure is as follows:

1. Push **[STOP]** key on microprocessor panel to shut down unit, then open disconnect switches for compressor and oil pump motor starters.

2. Close liquid supply service valve located before liquid solenoid.

WARNING Excessive pressure from expanding refrigerant trapped between stop valve and solenoid may cause gasket and o-ring failure and uncontrolled refrigerant release.

3. Close service valve located between the compressor and the liquid injection thermostatic valve.

4. Carefully loosen capscrews securing the strainer cover to the strainer. Allow pressure to relieve slowly.

5. When all entrapped refrigerant has been relieved, carefully remove loosened capscrews (as liquid refrigerant is sometimes caught in the strainer), strainer cover and strainer basket.

6. Wash the strainer basket and cover in solvent and blow clean with air.

7. Reassemble strainer.

8. Open service valve between compressor and liquid injection thermostatic valve and check for leakage.

9. Screw out manual solenoid valve stem.

10. Carefully open liquid supply service valve.

11. Leak test.

12. Close disconnect switches for compressor and oil pump motor starters.

13. Start unit.

COALESCER FILTER ELEMENT(S)

When changing the coalescer filter element(s) it is recommended that the oil be changed, cartridge(s) in oil filters OF-1 and OF-2 if applicable be changed and the following applicable strainer elements be removed and cleaned.

CAUTION Use of filter elements other than Frick may cause warranty claim may to be denied.

1. Refer to **CHANGING OIL**, Steps 1 through 8.

2. Loosen manway cover retainer bolts, remove retainers, manway cover and cover gasket. Discard cover gasket.

3. Remove and retain nut securing coalescer filter retainer.

4. Remove retainer, coalescer filter element and 2 O-rings. Discard filter elements.

5. Install new coalescer filter element(s).

CAUTION Seat element in center of locating tabs on separator bulkhead.

6. Replace coalescer filter retainer and nut. Torque nut to 21 ft-lb. **DO NOT OVERTIGHTEN NUT.**

7. Install new manway gasket and replace manway cover.

8. Tighten manway bolts. **NOTE: RETIGHTEN AFTER THE COMPRESSOR UNIT IS REPRESSURIZED, SINCE MANWAY BOLTS WILL LOOSEN.**

9. Refer to **CHANGING OIL**, Steps 9 through 14.

CHANGING OIL

WARNING **DO NOT MIX OILS** of different brands, manufacturers, or types. Mixing of oils may cause excessive oil foaming, nuisance oil level cutouts, oil pressure loss, gas or oil leakage and catastrophic compressor failure.

CAUTION Use of filter elements other than Frick may cause warranty claim may to be denied.

Shut down the unit when changing oil. At the same time all oil filter cartridges must be changed and all oil strainer elements removed and cleaned. The procedure is as follows:

1. Press the **[STOP]** key on the microprocessor panel to stop the compressor unit.

2. Open the disconnect switch for the compressor motor starter.

3. Close the suction and discharge service valves; also close the liquid-injection and economizer service valves, if applicable.

4. **SLOWLY** vent separator to low-side system pressure using the bypass line on the suction trap. **NOTE: Recover or transfer all refrigerant vapor, in accordance with local ordinances, before opening to atmosphere. The separator MUST be equalized to atmospheric pressure.**

CAUTION Oil entrained refrigerant may vaporize, causing a separator pressure increase. Repeat venting and recovery procedure, if necessary.

5. Open the drain valve(s) located on the underside of the separator and drain the oil.

6. Drain the oil filter(s) OF-1 and, if applicable, the oil coolers and filter OF-2.

7. Remove the old filter cartridges, then install new ones (as previously described in the section **OIL FILTER (OF-1) MAIN SINGLE/DUAL**).

8. Remove, clean, and reinstall strainer elements in the strainers.

9. Evacuate unit to 29.88" Hg (1000 microns) vacuum.

10. Open the suction service valve and pressurize the unit to system suction pressure. Close the suction valve and leak test.

11. Add oil by attaching a suitable pressure-type hose to the oil-charging valve located on top of the separator. Using a pressure-type oil pump and recommended Frick oil, open the charging valve and fill the separator until the oil level is midway in the top sight glass. **NOTE: Fill slowly because oil will fill up in the separator faster than it shows in the**

sight glass. Refer to the table in the **OIL CHARGE** section for approximate oil charge quantities.

12. Open the suction and discharge service valves, and also the liquid injection and economizer service valves, if applicable.

13. Close the disconnect switch for the compressor motor starter.

14. Start the unit.

DEMAND PUMP DISASSEMBLY



BEFORE OPENING ANY VIKING PUMP LIQUID CHAMBER (PUMPING CHAMBER, RESERVOIR, JACKET, ETC.) ENSURE:

1. THAT ANY PRESSURE IN THE CHAMBER HAS BEEN COMPLETELY VENTED THROUGH SUCTION OR DISCHARGE LINES OR OTHER APPROPRIATE OPENINGS OR CONNECTIONS.

2. THAT THE DRIVING MEANS (MOTOR, TURBINE, ENGINE, ETC.) HAS BEEN "LOCKED OUT" OR MADE NONOPERATIONAL SO THAT IT CANNOT BE STARTED WHILE WORK IS BEING DONE ON THE PUMP.

FAILURE TO FOLLOW ABOVE LISTED PRECAUTIONARY MEASURES MAY RESULT IN SERIOUS INJURY OR DEATH.

1. Mark head and casing before disassembly to ensure proper reassembly. The idler pin, which is offset in the pump head, must be positioned up and equal distance between port connections to allow for proper flow of liquid through the pump.

2. Remove the head capscrews.

3. Tilt top of head back when removing to prevent idler from falling off idler pin.

4. Remove idler and bushing assembly. If idler bushing needs replacing, see **INSTALLATION OF CARBON GRAPHITE BUSHINGS**.

5. Insert a brass bar or piece of hardwood in the port opening and between rotor teeth to keep shaft from turning. Turn

the locknut counterclockwise and remove locknut. See Figure 21 or 22.

6. Loosen two setscrews in face of bearing housing and turn thrust bearing assembly counterclockwise and remove from casing. See Figure 21 or 22.

7. **GG, HJ, HL:** Remove snap ring from shaft. See Figure 21. **AS, AK, AL:** Remove bearing spacer from shaft. See Figure 22.

8. Remove brass bar or piece of hardwood from port opening.

9. The rotor and shaft can now be removed by tapping on end of shaft with a lead hammer or, if using a regular hammer, use a piece of hardwood between shaft and hammer.

The rotary member of the seal will come out with rotor and shaft.

10. **AS, AK, AL:** Remove bearing retainer washer. The washer may have stayed with rotor and shaft when removed or is against ball bearing. See Figure 22.

11. Remove the mechanical seal rotary member and spring from rotor and shaft assembly.

12. **GG, HJ, HL:** Remove inner snap ring and single-row ball bearing from casing.

AS, AK, AL: Remove single-row ball bearing from casing.

13. Remove seal seat or stationary part of seal from casing.

14. Disassemble thrust-bearing assembly.

GG, HJ, HL: Remove outer snap ring from bearing housing and remove ball bearing. See Figure 21.

AS, AK, AL: Loosen two set screws in flange outside diameter. Rotate end cap and lip seal counterclockwise and remove. Remove ball bearing. See Figure 22.

The casing should be examined for wear, particularly in the area between ports. All parts should be checked for wear before pump is put together.

When making major repairs, such as replacing a rotor and shaft, it is advisable to also install a new mechanical seal, head and idler pin, idler, and bushing. See **INSTALLATION OF CARBON GRAPHITE BUSHINGS**.

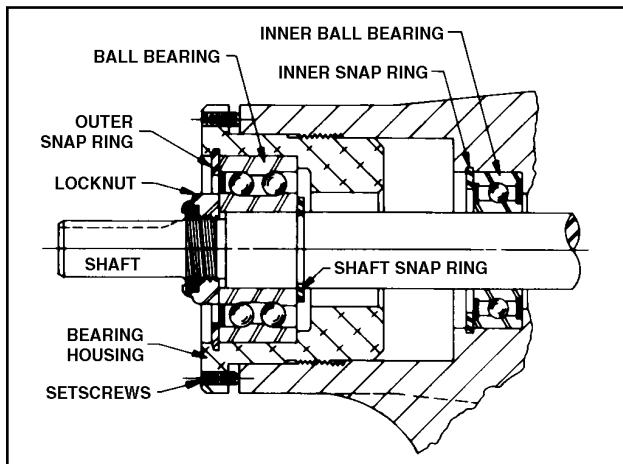

Figure 21. Thrust-Bearing assembly (GG, HJ, HL)

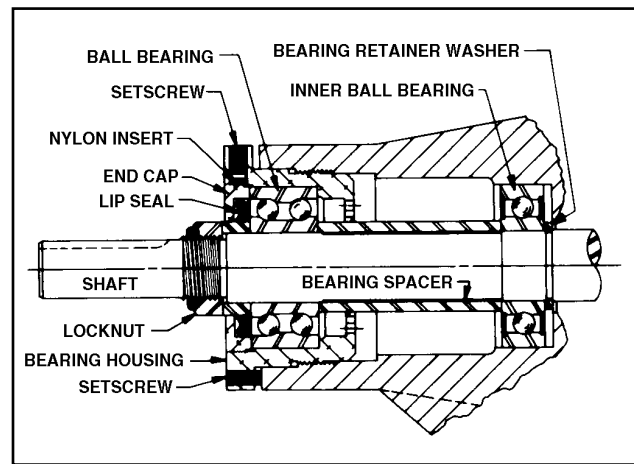

Figure 22. Thrust-Bearing assembly (AS, AK, AL)

Clean all parts thoroughly and examine for wear or damage. Check lip seals, ball bearings, bushing, and idler pin and replace if necessary. Check all other parts for nicks, burrs, excessive wear and replace if necessary.

Wash bearings in clean solvent. Blow out bearings with compressed air. Do not allow bearings to spin; turn them slowly by hand. Spinning bearings will damage race and balls. Make sure bearings are clean, then lubricate with refrigeration oil and check for roughness. Roughness can be determined by turning outer race by hand. Replace bearings if bearings have roughness.

Be sure shaft is free from nicks, burrs and foreign particles that might damage mechanical seal. Scratches on shaft in seal area will provide leakage paths under mechanical seal. Use fine emery cloth to remove scratches or sharp edges.

DEMAND PUMP ASSEMBLY

Assembly Notes On Standard Mechanical Seal (Synthetic Rubber Bellows Type)

NOTE: Read carefully before reassembling pump

The seal used in this pump is simple to install and good performance will result if care is taken during installation.

The principle of mechanical seal is contact between the rotary and stationary members. These parts are lapped to a high finish and their sealing effectiveness depends on complete contact.

Prior to installing rotary portion of mechanical seal, prepare and organize rotor shaft, head and idler assemblies and appropriate gaskets for quick assembly

Once rotary portion of mechanical seal is installed on rotor shaft, it is necessary to assemble parts as quickly as possible to ensure that the seal does not stick to shaft in wrong axial position. The seal will stick to the shaft after several minutes setting time.

Never touch sealing faces with anything except clean hands or clean cloth. Minute particles can scratch the seal faces and cause leakage.

1. Coat idler pin with refrigeration oil and place idler and bushing on idler pin in head. If replacing a carbon-graphite bushing, refer to "Installation of Carbon Graphite Bushings".

2. Clean rotor hub and casing seal housing bore. Make sure both are free from dirt and grit. Coat outer diameter of seal seat and inner diameter of seal housing bore with refrigeration oil.

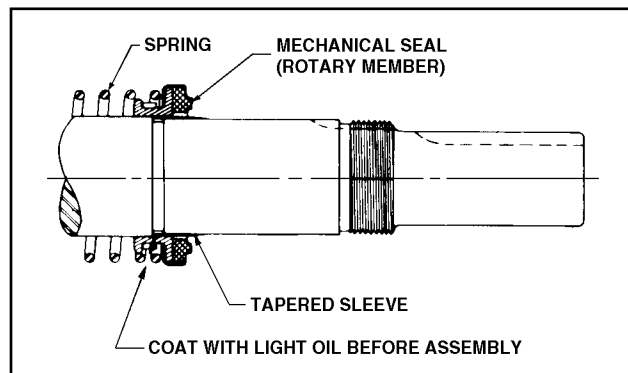

Figure 23

3. Start seal seat in seal housing bore. If force is necessary, protect seal face with a clean cardboard disc and gently tap it in place with a piece of wood. Be sure seal seat is completely seated in the bore.

4. Place tapered installation sleeve on shaft. Refer to Figure 23. Sleeve is furnished with GG, AS, AK, and AL replacement mechanical seals. Coat rotor shaft, tapered installation sleeve, and inner diameter of mechanical seal rotary member with a generous amount of refrigeration oil. Petrolatum may be used but grease is not recommended.

5. Place seal spring on shaft against rotor hub. Refer to Figure 24.

6. Slide rotary member, with lapped contact surface facing away from spring, over installation sleeve on shaft until just contacting the spring. Do not compress spring. Remove installation sleeve.

7. Coat rotor shaft with refrigeration oil. Install shaft slowly pushing until the ends of rotor teeth are just below the face of the casing.

8. Leave the rotor in this position. Withdrawal of rotor and shaft may displace the carbon seal rotating face and result in damage to the seal.

9. Place O-ring gasket on head and install head and idler assembly on pump. Pump head and casing were marked before disassembly to ensure proper reassembly. If not, be sure idler pin, which is offset in pump head, is positioned up and equal distance between port connections to allow for proper flow of liquid through pump.

10. Tighten head capscrews evenly

11. Pack inner ball bearing with multipurpose grease, NLGI #2.

GG, HJ, HL: Install bearing in casing with sealed side towards head end of pump. Drive the bearing into the bore. Tap the inner race with a brass bar and lead hammer to position bearing. Install inner snap ring.

AS, AK, AL: Install bearing retainer washer over the shaft before installing ball bearing. Install ball bearing in casing with sealed side towards head end of pump. Drive the bearing into the bore. Tap the inner race with a brass bar and lead hammer to position bearing.

12. **GG, HJ, HL:** Install shaft snap ring in groove in the shaft. See Figure 1.

AS, AK, AL: Install bearing spacer over shaft and against single-row ball bearing. See Figure 22.

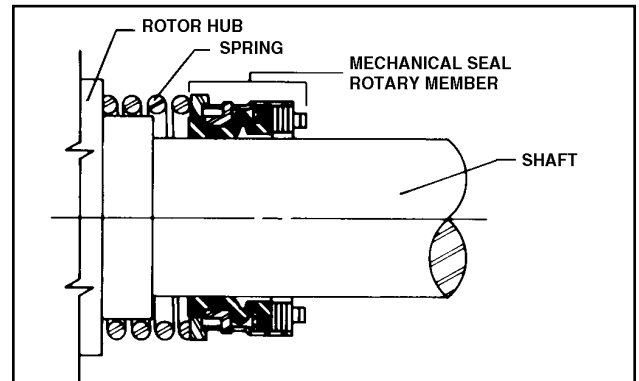

Figure 24

13. Pack lubrication chamber between inner ball bearing and double-row ball bearing in the thrust-bearing assembly approximately one-half full of multipurpose grease, NLGI #2. The thrust-bearing assembly will take the remaining space. See Figure 21 and 22.

14. Pack double-row ball bearing with multipurpose grease, NLGI #2.

GG, HJ, HL: Install ball bearing into bearing housing with shield side toward coupling end of shaft. See Figure 21. Install snap ring into bearing housing to retain ball bearing. This snap ring has a tapered edge to fit tapered groove in bearing housing. The tapered edge is located away from ball bearing.

AS, AK, AL: Install ball bearing into bearing housing. Install lip seal in bearing housing end cap. The lip should face towards end of shaft. Put bearing spacer collar in lip seal and install in bearing housing and tighten setscrews securely. See Figure 22.

15. Insert brass bar or hardwood through port opening between rotor teeth to keep shaft from turning.

16. Start thrust-bearing assembly into casing. Turn by hand until tight. This forces rotor against head. Replace and tighten locknut or shaft.

17. Remove brass bar or hardwood from port opening.

18. Adjust pump end clearance.

⚠ DANGER BEFORE STARTING PUMP, ENSURE THAT ALL DRIVE EQUIPMENT GUARDS ARE IN PLACE. FAILURE TO PROPERLY MOUNT GUARDS MAY RESULT IN SERIOUS INJURY OR DEATH.

THRUST BEARING ADJUSTMENT

See Figures 21 and 22.

Loosen two screws in face of thrust-bearing assembly.

If shaft cannot be rotated freely, turn thrust-bearing assembly counterclockwise until shaft can be turned easily.

1. While turning rotor shaft, rotate thrust-bearing assembly clockwise until noticeable drag occurs. This is zero end clearance.

2. Mark position of bearing housing with respect to the casing.

3. Rotate thrust-bearing assembly counterclockwise the distance listed below as measured on outside of bearing housing.

4. Tighten two setscrews in face of bearing housing after adjustment is made to secure thrust-bearing assembly position.

For viscosities above 2500 SSU, add additional end clearance (0.004" for GG, HJ and HL size pumps and 0.005" for AS, AK and AL size pumps).

Pump Size	Distance (in.) on O.D. of Bearing Housing	End Clearance (in.)
GG	7/16	.003
HJ, HL	9/16	.003
AS, AK, AL	1/2	.003

INSTALLATION OF CARBON GRAPHITE BUSHINGS

When installing carbon graphite bushings, extreme care must be taken to prevent breaking. Carbon graphite is a brittle material and easily cracked. If cracked, the bushing will quickly disintegrate. Using a lubricant and adding a chamfer on the bushing and the mating part will help in installation. The additional precautions listed below must be followed for proper installation:

1. A press must be used for installation.
2. Be certain bushing is started straight.
3. Do not stop pressing operation until bushing is in proper position. Starting and stopping will result in a cracked bushing.
4. Check bushing for cracks after installation.

TROUBLESHOOTING THE DEMAND PUMP

⚠ DANGER BEFORE OPENING ANY PUMP LIQUID CHAMBER (PUMPING CHAMBER, RESERVOIR, JACKET ETC.) ENSURE:

1. THAT ANY PRESSURE IN CHAMBER HAS BEEN COMPLETELY VENTED THROUGH SUCTION OR DISCHARGE LINES OR OTHER APPROPRIATE OPENINGS OR CONNECTIONS.
2. THAT THE DRIVING MEANS (MOTOR, TURBINE, ENGINE, ETC.) HAS BEEN "LOCKED OUT" OR MADE NONOPERATIONAL SO THAT IT CANNOT BE STARTED WHILE WORK IS BEING DONE ON PUMP.

FAILURE TO FOLLOW ABOVE LISTED PRECAUTIONARY MEASURES MAY RESULT IN SERIOUS INJURY OR DEATH.

Mark valve and head before disassembly to ensure proper reassembly.

If trouble does develop, one of the first steps toward finding the difficulty is to *install a vacuum gauge in the suction port and a pressure gauge in the discharge port*. Readings on these gauges often will give a clue as to where to start looking for the trouble.

Vacuum Gauge—Suction Port

1. High reading would indicate:
 - a. Suction line blocked - foot valve stuck, gate valve closed, strainer plugged.
 - b. Liquid too viscous to flow through the piping.
 - c. Lift too high.
 - d. Line too small.
2. Low reading would indicate -
 - a. Air leak in suction line.
 - b. End of pipe not in liquid.
 - c. Pump is worn.
 - d. Pump is dry - should be primed.
3. Fluttering, jumping, or erratic reading:
 - a. Liquid vaporizing.
 - b. Liquid coming to pump in slugs - possibly an air leak or insufficient liquid above the end of the suction pipe.
 - c. Vibrating from cavitation, misalignment, or damaged parts.

Pressure Gauge - Discharge Port

1. High reading would indicate:
 - a. High viscosity and small and/or long discharge line.
 - b. Gate valve partially closed.
 - c. Filter plugged.
 - d. Vertical head did not consider a high specific gravity liquid.
 - e. Line partially plugged from buildup on inside of pipe.
 - f. Liquid in pipe not up to temperature.
 - g. Liquid in pipe has undergone a chemical reaction and has solidified.
 - h. Relief valve set too high.
2. Low reading would indicate:
 - a. Relief valve set too low
 - b. Relief valve poppet not seating properly.
 - c. Too much extra clearance.
 - d. Pump worn.
3. Fluttering, jumping, or erratic reading:
 - a. Cavitation.
 - b. Liquid coming to pump in slugs.
 - c. Air leak in suction line.
 - d. Vibrating from misalignment or mechanical problems.

Some of the following may also help pinpoint the problem:

1. Pump does not pump.
 - a. Lost its prime - air leak, low level in tank.
 - b. Rotating in wrong direction.
 - c. Motor does not come up to speed.
 - d. Suction and discharge valves not open.
 - e. Strainer clogged.
 - f. Relief valve set too low, relief valve poppet stuck open.
 - g. Pump worn out.
 - h. Any changes in the liquid system, or operation that would help explain the trouble, e.g. new source of supply, added more lines, inexperienced operators, etc.
 - i. Tighten end clearance.
 - j. Head position incorrect.
2. Pump starts, then loses its prime.
 - a. Low level in tank.
 - b. Liquid vaporizing in the suction line.
 - c. Air leaks or air pockets in the suction line; leaking air through packing or mechanical seal.
 - d. Worn out.
3. Pump is noisy
 - a. Pump is being starved (heavy liquid cannot get to pump fast enough). Increase suction pipe size or reduce length.
 - b. Pump is cavitating (liquid vaporizing in the suction line). Increase suction pipe size or reduce length; if pump is above the liquid, raise the liquid level closer to the pump; if the liquid is above the pump, increase the head of liquid.
 - c. Check alignment.
 - d. May have a bent shaft or rotor tooth. Straighten or replace.
 - e. May be a foreign object trying to get into the pump through the suction port.
4. Pump not up to capacity
 - a. Starving or cavitating - increase suction pipe size or reduce length.
 - b. Strainer partially clogged - clean.
 - c. Air leak in suction piping or along pump shaft.

- d. Running too slowly - is motor the correct speed and is it wired up correctly
 - e. Relief valve set too low or stuck open.
 - f. Pump worn out.
 - g. Tighten end clearance.
 - h. Head position incorrect.
5. Pump takes too much power.
 - a. Running too fast - is correct motor speed, reducer ratio, sheave size, etc. being used.
 - b. Liquid more viscous than unit sized to handle - heat the liquid, increase the pipe size, slow the pump down, or get a bigger motor.
 - c. Discharge pressure higher than calculated - check with pressure gauge. Increase size or reduce length of pipe, reduce speed (capacity), or get bigger motor.
 - d. Pump misaligned.
 - e. Extra clearance on pumping elements may not be sufficient for operating conditions. Check parts for evidence of drag or contact in pump and increase clearance where necessary
6. Rapid Wear.

Examination of a pump that has gradually lost its ability to deliver capacity or pressure would show a smooth wear pattern on all parts. Rapid wear shows up as heavy grooving, galling, twisting, breaking, or similar severe signs of trouble.

PREVENTATIVE MAINTENANCE

Performing a few preventative maintenance procedures will extend the life of your pump and reduce the cost per gallon pumped.

1. Lubrication - Grease all zerks after every 500 hours of operation or after 60 days, whichever occurs first. If service is severe, grease more often. Do it gently with a hand gun. Use #2 ball bearing grease for normal applications. For hot or cold applications, use appropriate grease.

2. Packing Adjustment - Occasional packing adjustment may be required to keep leakage to a slight weep; if impossible to reduce leakage by gentle tightening, replace packing or use different type. See Technical Service Manual on particular model series for details on repacking.

3. End Clearance Adjustment - After long service the running clearance between the end of the rotor teeth and the head may have increased through wear to the point where the pump is losing capacity or pressure. Resetting end clearance will normally improve pump performance. See Technical Service Manual on particular model series for procedure on adjusting end clearance for the pump involved.

**RECOMMENDED
MAINTENANCE PROGRAM**

In order to obtain maximum compressor unit performance and ensure reliable operation, a regular maintenance program should be followed.

The compressor unit should be checked daily for leaks, abnormal vibration, noise, and proper operation. A log should also be maintained. There should be continued monitoring of oil quality and oil analysis testing. In addition, an analysis of the unit's vibration should be periodically made.

VIBRATION ANALYSIS

Periodic vibration analysis can be useful in detecting bearing wear and other mechanical failures. If vibration analysis is used as a part of your preventive maintenance program, take the following guidelines into consideration.

1. Always take vibration readings from exactly the same places and at exactly the same percentage of load.
2. Use vibration readings taken from the new unit at start-up as the base line reference.
3. Evaluate vibration readings carefully as the instrument range and function used can vary. Findings can be easily misinterpreted.
4. Vibration readings can be influenced by other equipment operating in the vicinity or connected to the same piping as the unit.

OIL QUALITY and ANALYSIS

High quality refrigeration oil is necessary to ensure compressor longevity and reliability. Oil quality will rapidly deteriorate in refrigeration systems containing moisture and air or other

contaminants. In order to ensure the quality of the refrigeration oil in the compressor unit:

1. Only use Frick filter elements or warranty claim may be denied.
2. Participate in a regular, periodic oil analysis program to maintain oil and system integrity.

OPERATING LOG

The use of an operating log as included in this manual (see Table of Contents) permits thorough analysis of the operation of a refrigeration system by those responsible for its maintenance and servicing. Continual recording of gauge pressures, temperatures, and other pertinent information, enables the observer and serviceman to be constantly familiar with the operation of the system and to recognize immediately any deviations from normal operating conditions. It is recommended that readings be taken at least every four hours.

MOTOR BEARINGS

Follow the motor manufacturer's maintenance recommendations for lubrication. See illustration of schedule for standard motor, Figure 25.

MAINTENANCE SCHEDULE

This schedule should be followed to ensure trouble-free operation of the compressor unit.

MAINTENANCE	FREQUENCY OR HOURS OF OPERATION (MAXIMUM)																						
	200	1000	5000	8000	10,000	15,000	20,000	25,000	30,000	35,000	40,000	45,000	50,000	55,000	60,000	65,000	70,000	75,000	80,000	85,000	90,000	95,000	
Change Oil	As Directed By Oil Analysis																						
Oil Analysis		■	Every 6 Months																				
Replace Filters	■		■		■		■		■		■		■		■		■		■		■		■
Clean Oil Strainers	■		■		■		■		■		■		■		■		■		■		■		■
Clean Liquid Strainers	■		■		■		■		■		■		■		■		■		■		■		■
Replace Coalescers									■						■								■
Check and Clean Suction Strainer	■		■		■		■		■		■		■		■		■		■		■		■
Check Coupling (a)	■	Annually Regardless of Operating Hours																					
Suction & Disch Flange Bolts (d)	■	■	■	■	■	■	■	■	■	■	■	■	■	■	■	■	■	■	■	■	■	■	■
Check Electrical Connections (b)	■		■		■		■		■		■		■		■		■		■		■		■
Check Sensor Calibration (c)	■	■	■		■	■	■	■	■	■	■	■	■	■	■	■	■	■	■	■	■	■	■
Vibration Analysis (e)	■	Every 6 Months, More Frequently If Levels Increase																					
Replace Shaft Seal	When Leak Rate Exceeds 7 - 8 Drops Per Minute																						

- Check bolts, shim packs, center inserts, keys, and all bolt torques.
- Check and torque all terminals in the processor and starter panel per the specification posted in the enclosure.
- Check calibration of Slide Valve, Slide Stop, pressures and temperatures.
- Verify tightness of bolts on suction and discharge flanges. See table below for torque requirements.
- Vibration measurement must be carried out continuously to obtain optimum preventative control on bearings. If not continuously controlled, then every 6 months, more frequently if levels increase.

RWF MODEL	Compressor Model	Discharge Flange to Separator Flange		Suction Flange	
		Bolt Size	Torque* (ft-lb)	Bolt Size (in.)	Torque* (ft-lb)
100	SGC 1913	M20 X 2.5	140	M20 X 2.5	180
134	SGC 1918	M20 X 2.5	140	M20 X 2.5	160
177	SGC 2313	M20 X 2.5	160	M20 X 2.5	160
222	SGC 2317	M20 X 2.5	160	M20 X 2.5	200
270	SGC 2321	M20 X 2.5	160	M22 X 2.5	220
316	SGC 2813	M22 X 2.5	230	M22 X 2.5	220
399	SGC 2817	M22 X 2.5	230	M22 X 2.5	220
480	SGC 2821	M22 X 2.5	230	M24 X 3.0	220

* Based on: Gaskets-Garlock® Blue-Gard® 3300; Bolts-class 8.8 or stronger hex head bolts, lightly oiled and clean



Make sure the motor bearings are properly lubricated before start-up as required by the motor manufacturer.

GREASE COMPATIBILITY

If it becomes necessary to mix greases, be careful not to combine different oil bases or thickeners. DO NOT mix a mineral oil-base grease with a synthetic oilbase grease. Also, a grease with a lithium thickener should not be mixed with one containing a sodium thickener. The table illustrates the compatibility of various types of grease based on results by National Lubricating Grease Institute (NLGI). The chart indicates a great variance in compaibility with the greases tested.

NLGI Grease Compatibility Chart

	Aluminum Complex	Barium	Calcium	Calcium 12-hydroxy	Calcium Complex*	Clay	Lithium	Lithium 12-hydroxy	Lithium Complex	Polyurea
Aluminum Complex	-	I	I	C	I	I	I	I	C	I
Barium	I	-	I	C	I	I	I	I	I	I
Calcium	I	I	-	C	I	C	C	B	C	I
Calcium 12-hydroxy	C	C	C	-	B	C	C	C	C	I
Calcium Complex	I	I	I	B	-	I	I	I	C	C
Clay	I	I	C	C	I	-	I	I	I	I
Lithium	I	I	C	C	I	I	-	C	C	I
Lithium 12-hydroxy	I	I	B	C	I	I	C	-	C	I
Lithium Complex	C	I	C	C	C	I	C	C	-	I
Polyurea*	I	I	I	I	C	I	I	I	I	-

B = Borderline Compatibility
C = Compatible
I = Incompatible
* Standard

TROUBLESHOOTING GUIDE

Successful problem solving requires an organized approach to define the problem, identify the cause, and make the proper correction. Sometimes it is possible that two relatively obvious problems combine to provide a set of symptoms that can mislead the troubleshooter. Be aware of this possibility and avoid solving the “wrong problem”.

ABNORMAL OPERATION ANALYSIS and CORRECTION

Four logical steps are required to analyze an operational problem effectively and make the necessary corrections:

1. Define the problem and its limits.
2. Identify all possible causes.
3. Test each cause until the source of the problem is found.
4. Make the necessary corrections.

The first step in effective problem solving is to define the limits of the problem. If, for example, the compressor periodically experiences high oil temperatures, do not rely on this observation alone to help identify the problem. On the basis of this information the apparent corrective measure would appear to be a readjustment of the liquid injection system. Lowering the equalizing pressure on the thermal expansion valve would increase the refrigerant feed and the oil temperature should drop.

If the high oil temperature was the result of high suction superheat, however, and not just a matter of improper liquid injection adjustment, increasing the liquid feed could lead to other problems. Under low load conditions the liquid injection system may have a tendency to overfeed. The high suction superheat condition, moreover, may only be temporary. When system conditions return to normal the units' liquid injection will overfeed and oil temperature will drop. In solving the wrong problem a new problem was created.

LUBRICATION SCHEDULE / INSTRUCTIONS

SYNC. RPM	FRAME SERIES	SERVICE CYCLE* - BALL BEARING**	
		8 HR/DAY OPERATION	24 HR/DAY OPERATION
3600	360-5800	150 DAYS (1200 HRS)	50 DAYS (1200 HRS)
	360	390 DAYS (3120 HRS)	130 DAYS (3120 HRS)
1800	400-440	270 DAYS (2160 HRS)	90 DAYS (2160 HRS)
	5000-5800	210 DAYS (1680 HRS)	70 DAYS (1680 HRS)
1200	360-440	390 DAYS (3120 HRS)	130 DAYS (3120 HRS)
	5000-5800	270 DAYS (2160 HRS)	90 DAYS (2160 HRS)

* LUBRICATION SCHEDULE FOR SEVERE SERVICE (VIBRATION, SHOCK AND/OR ENVIRONMENTAL EXTREME) = 1/3 OF THE ABOVE INTERVALS.

** LUBRICATION SCHEDULE FOR ROLLER BEARINGS = 1/3 OF ABOVE INTERVALS.

THE FACTORY INSTALLED, RECOMMENDED LUBRICANT IS LISTED ON THE MOTOR DATA PLATE. THIS IS A POLYUREA GREASE, AS ARE THE PRODUCTS LISTED BELOW. THE INTRODUCTION OF LUBRICANTS OF ALTERNATE CHEMICAL MAKEUP IS NOT RECOMMENDED AND WILL CAUSE MECHANICAL FAILURE WITHOUT THE COMPLETE PURGE OF THE FACTORY PRODUCT FROM THE BEARING AND RESERVOIR. WHEREVER POSSIBLE, APPLY THE POLYUREA PRODUCT.

CHEVRON OIL CO. - SRI#2 EXXON CORP. - POLYREX EM SHELL OIL CO. - DOLIUM R

- LUBRICATE BEARINGS WITH POWER IN THE OFF CONDITION.
- CLEAR AND CLEAN THE GREASE FITTINGS AND SURROUNDING AREA.
- REMOVE THE PIPE PLUG FROM THE VENTING PORT OPPOSITE THE GREASE FITTING.
- USING A LOW PRESSURE GREASE GUN APPLY 2 OZS. (60 GRAMS) OF GREASE AT EACH FITTING. DO NOT OVERGREASE.
- WITH THE VENT PORTS OPEN, OPERATE THE MOTOR FOR A MINIMUM OF 15 MINUTES AND UNTIL ANY GREASE FLOW HAS CEASED AT THE VENTING PORTS.
- REMOVE POWER.
- REPLACE THE VENT PIPE PLUGS.
- REPLACE ANY AND ALL GUARDS AND COVERS THAT MAY HAVE BEEN REMOVED TO ACCESS THE MOTOR.

Figure 25

When an operating problem develops compare all operating information on the MAIN OPERATING SCREEN with normal operating conditions. If an Operating Log has been maintained the log can help determine what constitutes normal operation for the compressor unit in that particular system.

The following list of abnormal system conditions can cause abnormal operation of the RWF compressor unit:

1. Insufficient or excessive refrigeration load.
2. Excessively high suction pressure.
3. Excessively high suction superheat.
4. Excessively high discharge pressure.
5. Inadequate refrigerant charge or low receiver level.
6. Excessively high or low temperature coolant to the oil cooler.
7. Liquid return from system (slugging).
8. Refrigerant underfeed or overfeed to evaporators.
9. Blocked tubes in water-cooled oil cooler from high mineral content of water.
10. Insufficient evaporator or condenser sizing.
11. Incorrect refrigerant line sizing.
12. Improper system piping.
13. Problems in electrical service to compressor unit.
14. Air and moisture present in the system.

Make a list of all deviations from normal plant operation and normal compressor unit operation. Delete any items which do not relate to the symptom and separately list those items that might relate to the symptom. Use the list as a guide to further investigate the problem.

The second step in problem solving is to decide which items on the list are possible causes and which items are additional symptoms. High discharge temperature and high oil temperature readings on a display may both be symptoms of a problem and not casually related. High suction superheat or a low receiver level, however, could cause both symptoms.

The third step is to identify the most likely cause and take action to correct the problem. If the symptoms are not relieved move to the next item on the list and repeat the procedure until you have identified the cause of the problem. Once the cause has been identified and confirmed make the necessary corrections.

SERVICING THE COLD-START VALVE



DO NOT ATTEMPT TO SERVICE THE YORK REFRIGERATION/GRAM COLD START VALVE. PLEASE CONTACT THE FRICK SERVICE DEPARTMENT.

THE FOLLOWING INSTRUCTIONS SHOULD BE USED FOR SURVICING THE YORK REFRIGERATION/DANFOSS COLD-START VALVE.

Before beginning to disassemble the valve, the refrigerant must be removed from all associated piping.

Start room ventilation and put on a safety mask.



Be extremely careful when dismantling the cold-start valve on the discharge side of the unit, as condensed refrigerant often is trapped between the cold-start valve and the stop valve. Exposure to refrigerant fumes can cause injury or death.

After the bonnet assembly is mounted into the valve housing



Inside the valve (see Figure 28) there is a very heavy, tight spring (15). Provided the valve is intact,

the spring presents no danger when dismantling. The spring is compressed with a large bolt (7). If it is necessary to repair the valve, it can be dismantled as follows:

1. To manually open the valve, mount the hexagon screw (29), the hexagon flange nut (28) and the nylon ring (27) as shown. Tighten the nut (28) a few turns, in order to redraw the valve cone from the seat.

NOTE: Step 1 is not strictly necessary when dismantling the valve, but will prevent the valve seat gasket from being exposed to a shear load, and it will keep all internal valve parts together as a unit.

2. Loosen the screws (24) by 0.315 in (8 mm), and ensure that the bonnet (2) is not under pressure from the spring.

If the bonnet is under pressure from the spring (15) after all the screws have been loosened by 0.315 in (8 mm), there is a damage inside the valve. In this case, it is important to remove only two screws, one from each side.

In the threaded holes from which the two screws have been removed, insert studs with nuts (see table for screw size) and turn the nuts down to meet the bonnet (2). The studs must be about the same length as the valve body. Then remove the remaining two screws (24), loosen the nuts on the studs, and carefully ease off the bonnet. All internal parts can then be safely removed. **NOTE: If step 1 was followed, loosen the hexagon nut (28) carefully, holding the hexagon screw (29) in place.**

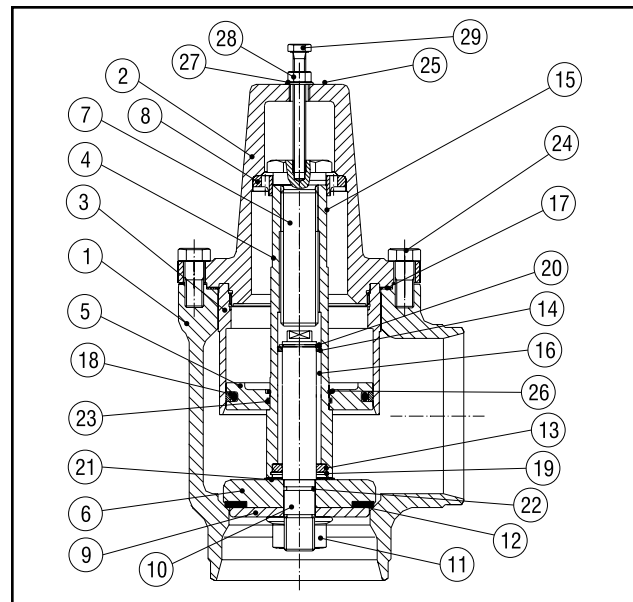

Figure 28 - Cold-Start Valve

If the bonnet is not under pressure from the spring, all screws (24) can be removed. The bonnet and all internal parts can now be removed from the valve body.

When internal parts have been taken out of the valve body, the spring can be removed by unscrewing the spring bolt (7).

NOTE: When assembling the valve, the bonnet gasket (17) must be captured in the groove in the bonnet (2).

After the bonnet assembly is mounted into the valve housing

(1), install and tighten bonnet cap screws (24). The required torque is shown for each valve size in the following BONNET CAP SCREW TORQUE VALUES table.

BONNET CAP SCREW TORQUE VALUES

Valve Size DN (mm)	Torque (Nm)	Valve Size ANSI	Torque (lb-ft)	Screw Size (mm)
65	74	2 1/2"	54	M12
80	44	3"	32	M10
100	74	4"	54	M12
125	183	5"	134	M16
150	183	6"	134	M16
200	370	8"	271	M20

PRESSURE TRANSDUCERS - TESTING

1. Shut down the compressor and allow pressures to equalize.

2. Isolate suction transducer PE-4 from the unit and depressurize. **NOTE: Recover or transfer all refrigerant vapor, in accordance with local ordinances, before opening to atmosphere.**

3. Measure the voltage of PE-4 on connector P4 (terminals WHT and BLK) on the SBC with a digital voltmeter.

4. The voltage reading should be 1.48 VDC to 1.72 VDC at standard atmospheric pressure (14.7 PSIA or 0 PSIG). When checking transducers at higher elevations, an allowance in the readings must be made by subtracting approximately 0.02 VDC per 1000 feet of elevation above sea level. Therefore, if PE-4 is measured at 5000 feet elevation under relatively normal weather conditions, the output voltage should differ by 0.10 VDC to read between 1.38 VDC and 1.62 VDC.

5. Isolate the oil pressure transducer PE-1 from the package and open it to atmosphere.

6. Measure the voltage of PE-1 on connector P4 (terminals WHT and BLK) on the SBC.

7. The voltage reading should be between 1.1 VDC and 1.29 VDC at standard atmospheric pressure. PE-1, PE-2, and PE-3 all have a span of 500 PSI as compared to PE-4 with a span of 200 PSI. Therefore, atmospheric pressure changes have a lesser effect which is 0.0067 VDC per 1000 feet of elevation and 0.00067 VDC per 0.1 inch Hg barometric deviation.

8. Isolate transducer PE-2 from the package and depressurize. **NOTE: Recover or transfer all refrigerant vapor, in accordance with local ordinances, before opening to atmosphere.**

9. Measure the voltage of PE-2 on connector P4 (terminals WHT and BLK) on the SBC.

10. The voltage reading should be between 1.1 VDC and 1.29 VDC at standard atmospheric pressure (see Step 12).

11. Since the discharge pressure, PE-3, cannot be closed off from its sensing point (code requirements), close all transducers from atmosphere and open them to their sensing points so all transducers can equalize to separator pressure.

12. Measure the voltage of PE-3 on connector P4 (terminals WHT and BLK) on the SBC.

PRESSURE TRANSDUCER CONVERSION DATA				
Sensor Voltage	200 psi		500 psi	
	Range - PSIG*		Range - PSIG*	
	low	high	low	high
1.0	29.92"	9.57"	29.92"	4.1
1.1	29.92"	0.3	29.92"	16.6
1.2	29.92"	5.3	17.10"	29.1
1.3	19.74"	10.3	4.1	41.6
1.4	9.57"	15.3	16.6	54.1
1.5	0.3	20.3	29.1	66.6
1.6	5.3	25.3	41.6	79.1
1.7	10.3	30.3	54.1	91.6
1.8	15.3	35.3	66.6	104.1
1.9	20.3	40.3	79.1	116.6
2.0	25.3	45.3	91.6	129.1
2.1	30.3	50.3	104.1	141.6
2.2	35.3	55.3	116.6	154.1
2.3	40.3	60.3	129.1	166.6
2.4	45.3	65.3	141.6	179.1
2.5	50.3	70.3	154.1	191.6
2.6	55.3	75.3	166.6	204.1
2.7	60.3	80.3	179.1	216.6
2.8	65.3	85.3	191.6	229.1
2.9	70.3	90.3	204.1	241.6
3.0	75.3	95.3	216.6	254.1
3.1	80.3	100.3	229.1	266.6
3.2	85.3	105.3	241.6	279.1
3.3	90.3	110.3	254.1	291.6
3.4	95.3	115.3	266.6	304.1
3.5	100.3	120.3	279.1	316.6
3.6	105.3	125.3	291.6	329.1
3.7	110.3	130.3	304.1	341.6
3.8	115.3	135.3	316.6	354.1
3.9	120.3	140.3	329.1	366.6
4.0	125.3	145.3	341.6	379.1
4.1	130.3	150.3	354.1	391.6
4.2	135.3	155.3	366.6	404.1
4.3	140.3	160.3	379.1	416.6
4.4	145.3	165.3	391.6	429.1
4.5	150.3	170.3	404.1	441.6
4.6	155.3	175.3	416.6	454.1
4.7	160.3	180.3	429.1	466.6
4.8	165.3	185.3	441.6	479.1
4.9	170.3	190.3	454.1	491.6
5.0	175.3	195.3	466.6	504.1
At 0 psig	1.094 V	1.494 V	0.968 V	1.268 V

* Below 0 PSIG measured in inches of mercury.

13. Measure the voltage of PE-1 on connector P4 (terminals WHT and BLK) on the SBC.

14. These two voltages should be within .04 VDC of one another.

15. Test is complete.

PRESSURE TRANSDUCERS - REPLACEMENT

1. Shut off control power.

2. Close the applicable transducer isolation valve. **NOTE: To change the discharge pressure transducer (PE-3), it will be necessary to depressurize the entire compressor package. Follow "General Instructions For Replacing Compressor Unit Components" before going to step 3.**

3. Refer to the WIRING HARNESS section, External Transducers for Board #1, to identify the wiring harness connectors.

4. Loosen screw and disconnect wiring harness connector from transducer.
5. Unscrew the transducer using a wrench on the metal hex at the base of the transducer. **DO NOT ATTEMPT TO LOOSEN OR TIGHTEN TRANSDUCERS BY THEIR TOP CASING.**
6. Install new transducer.
7. Reconnect the wiring harness to the transducer.
8. Reopen the transducer isolation valve.
9. Turn on control power.

NOTE: The Pressure Transducer is factory set. If calibration is required, refer to Analog Calibration Instruction in publication S90-010 M-ADD.

SV POSITION POTENTIOMETER REPLACEMENT AND ADJUSTMENT

The Slide Valve Position potentiometer is located on the end of the compressor unloader cylinder (applies to models 100 - 270), see Figure 26.

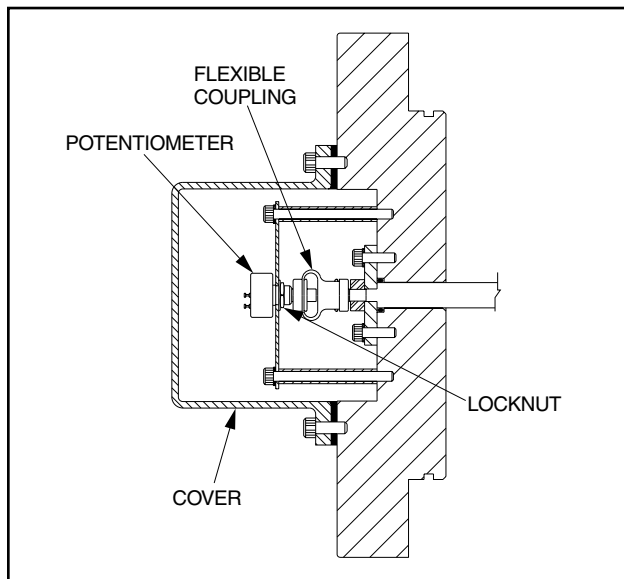

Figure 26

1. Shut off control power.
2. Remove the four socket head cap screws securing the potentiometer cover to the unloader cylinder.
3. Unsolder leads to the potentiometer and remove.
4. Loosen the setscrew on the potentiometer side of the flexible coupling.
5. Remove the three retainer clips securing the potentiometer to the base plate. The potentiometer should slip out of the coupling.
6. Install the new potentiometer and reassemble.
7. Adjustment:

ROUGH ADJUSTMENT is made with the slide valve fully unloaded and the control power off. Remove connector P5. With a digital voltmeter, measure the resistance across the red and white wires, having removed them from the SBC.

The resistance should be 1000 +/- 50 ohms. If adjustment is necessary, loosen the locknut and rotate the potentiometer clockwise or counterclockwise until the resistance reading is a close to a 1000 ohms as possible. Retighten the locknut and replace wires. **NOTE: Mechanical travel of the slide valve potentiometer is 300 degrees rotation when the slide stop is confirmed to be in the 2.2 Vi position. The travel will be less than 300 degrees if the slide stop is in any position above 2.2 Vi.**

FINE ADJUSTMENT must be made with the slide valve fully unloaded and the compressor running. The Operating display at this time should indicate a slide valve position of 0%. If the display is greater than 0%, adjust potentiometer POT #4 on the SBC until 0% is indicated. If 0% is not attainable, get as close as possible and then proceed to the next step. The adjustments of POT #4 and POT #3 are interactive and POT #3 may require adjustment to allow POT #4 to come into range.

Completely load the slide valve. The display at this time should indicate 100%. If the display is less than 100%, adjust potentiometer POT #3 on the SBC until 100% is indicated.

Repeat this sequence until the slide valve indicates 0% fully unloaded and 100% fully loaded.

CAPACITY LINEAR TRANSMITTER REPLACEMENT - SLIDE VALVE

The Capacity Linear Transmitter is located on the end of the compressor unload cylinder (applies to models 100 - 270), see Figure 27.

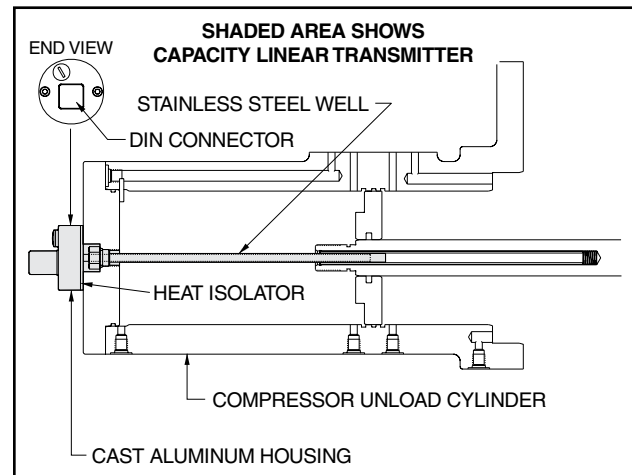

Figure 27

The linear transmitter with hermetic enclosure is based on the inductive measuring principle. It features removable electronics (from the sensor well) eliminating the need to evacuate the compressor for replacement. This type of transmitter is dedicated to capacity control and is not adjustable.

1. Shut off control power.
2. Remove DIN connector plug from transmitter.
3. Loosen cap screws.
4. Remove transmitter unit.
5. Install new transmitter unit.
6. Tighten cap screws.

7. Apply DIN connector plug to transmitter.
8. Turn on control power.

NOTE: For calibration instructions, refer to Quantum™ Operator's Manual, S90-010 O.

VOLUMIZER® TRANSMITTER REPLACEMENT - SLIDE STOP

The VOLUMIZER® Transmitter is located on the right side of the compressor (facing shaft) at the inlet end (see Figure 28).

The linear transmitter with hermetic enclosure is based on the inductive measuring principle. It features removable electronics (from the sensor well) eliminating the need to evacuate the compressor for replacement. This type of transmitter is dedicated to volume ratio control and has no user adjustments.

1. Shut off control power.
2. Remove DIN connector plug from transmitter.
3. Loosen set screws.
4. Remove transmitter unit.
5. Install new transmitter unit.
6. Tighten set screws.
7. Apply DIN connector plug to transmitter.
8. Turn on control power.

NOTE: For calibration of the Volumizer® unit, refer to the Analog Calibration instructions in publication S90-010 O.

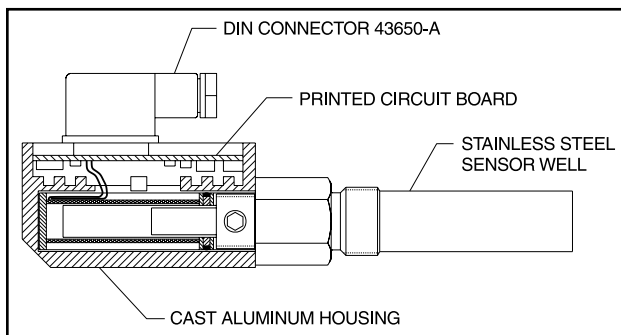

Figure 28 - VOLUMIZER® TRANSMITTER

TEMPERATURE SENSOR REPLACEMENT



This device is static sensitive. Please follow proper ESD procedures when handling.

1. Shut off control power.
2. Remove DIN connector plug from transmitter, Figure 30.
3. Unscrew knurled ring and remove transmitter unit.
4. Apply thermal compound to new sensor assembly, insert into thermal well, and tighten knurled ring.
5. Apply DIN connector plug to transmitter.

6. Turn on control power.

NOTE: The temperature sensor is factory set. If calibration is required, refer to Analog Calibration instructions in publication S90-010 O.

OIL LEVEL TRANSMITTER REPLACEMENT

The Oil Level Transmitter is located on the front of the separator near the bottom/center (see Figure 29).

The linear transmitter with hermetic enclosure is based on the capacitive measuring principle. It features removable electronics (from the sensor well) eliminating the need to evacuate the compressor for replacement. This transmitter is dedicated to oil level control and has no user adjustments.

1. Shut off control power.
2. Remove DIN connector plug from transmitter.
3. Loosen set screws.
4. Remove transmitter unit.
5. Install new transmitter unit.
6. Tighten set screws.
7. Apply DIN connector plug to transmitter.
8. Turn on control power.

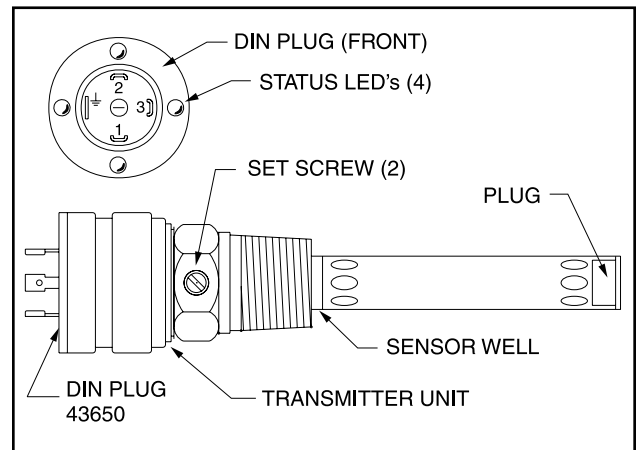

Figure 29 - OIL LEVEL TRANSMITTER

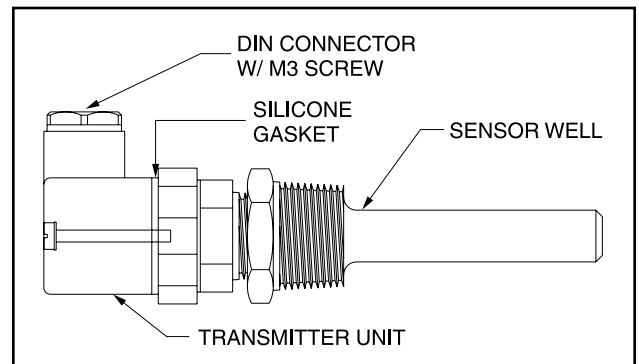

Figure 30 - TEMPERATURE TRANSMITTER

TROUBLESHOOTING THE RWF COMPRESSOR

SYMPTOM	PROBABLE CAUSES and CORRECTIONS
EXCESSIVE NOISE and VIBRATION	<p>Main oil injection valve may be closed. Open valve.</p> <p>Bearing damage or excessive wear. CONTACT Frick Factor or Frick service.</p> <p>Coupling loose on shaft. Tighten coupling. Replace if damaged.</p> <p>If motor or compressor have been reinstalled, check that installation done according to S70-660 SM</p> <p>Refrigerant flood back. Correct system problem.</p>
SLIDE VALVE and/or SLIDE STOP WILL NOT MOVE	<p>4-way hydraulic control valve failed. Repair or replace.</p> <p>Slide stop indicator rod stuck. Contact Frick Factor or Frick service for assistance.</p> <p>Check both S.V. and S.S. feedback devices for wiring and resistance.</p> <p>Compressor must be running with sufficient oil pressure.</p> <p>Unloader piston stuck. Contact Frick Factor or Frick service for assistance.</p> <p>Slipper seals worn out or damaged. Contact Frick Factor or Frick service for assistance.</p>

NOTE: Troubleshooting the compressor is limited to identifying the probable cause. If a mechanical problem is suspected contact the Service Department, Frick . DO NOT ATTEMPT TO DISASSEMBLE COMPRESSOR.

TROUBLESHOOTING THE OIL SEPARATION SYSTEM

SYMPTOM	PROBABLE CAUSES and CORRECTIONS
GRADUAL OIL LOSS WITH AN OIL LEVEL IN THE COALESCER SECTION SIGHT GLASS	<p>Maintaining too high an oil level, lower level.</p> <p>Refrigerant carryover or liquid injection overfeeding, correct operation.</p> <p>Loss of suction superheat. Adjust evaporator feeds.</p> <p>Contaminated oil, damaged or not seated coalescer filter elements. Replace oil charge and coalescers.</p> <p>Coalescer return valve closed. Open return valve.</p> <p>Coalescer return valve closed. Open valve.</p> <p>Coalescing oil return line strainer blocked. Clean.</p> <p>Needle valve blocked. Clean.</p>
RAPID OIL LOSS WITH NO OIL LEVEL IN THE COALESCER SECTION SIGHT GLASS	<p>On shutdown, compressor unit suction check valve did not close. Repair valve.</p> <p>Suction check valve bypass valve open. Close valve.</p> <p>Coalescers loose or not seated properly. Correct or replace.</p> <p>On economized unit: economizer check valve not working. Repair or replace.</p> <p>Economizer check valve not in automatic position or manually opened. Place in auto position.</p>
SHAFT SEAL LEAKAGE	<p>If leakage exceeds normal allowable rate of 7 drops per minute, replace seal.</p>

TROUBLESHOOTING THE HYDRAULIC SYSTEM

SYMPTOM	PROBABLE CAUSES and CORRECTIONS
SLIDE VALVE WILL NOT LOAD OR UNLOAD	<p>Solenoid coils may be burned out. Replace.</p> <p>Valve may be closed. Open hydraulic service valves.</p> <p>Solenoid spool may be stuck or centering spring broken. Replace.</p> <p>Check outputs 2 and 3 and fuses.</p> <p>Check LED on coil. If lit, there is power to the coil. Check coil.</p> <p>Solenoid may be actuated mechanically by inserting a piece of 3/16" rod against armature pin and pushing spool to opposite end. Push A side to confirm unload capability. If valve works, problem is electrical.</p>
SLIDE VALVE WILL LOAD BUT WILL NOT UNLOAD	<p>A side solenoid coil may be burned out. Replace.</p> <p>Dirt inside solenoid valve preventing valve from operating both ways. Clean.</p> <p>Check LED on coil. If lit, valve is functioning mechanically. Problem is electrical.</p> <p>Solenoid may be actuated mechanically by inserting a piece of 3/16" rod against armature pin and pushing spool to opposite end. Push A side to confirm unload capability. If valve works, problem is electrical.</p>
SLIDE VALVE WILL UNLOAD BUT WILL NOT LOAD	<p>A side solenoid coil may be burned out. Replace.</p> <p>Dirt inside solenoid valve preventing valve from operating both ways. Clean.</p> <p>Check LED on coil. If lit, valve is functioning mechanically. Problem is electrical.</p> <p>Solenoid may be actuated mechanically by inserting a piece of 3/16" rod against armature pin and pushing spool to opposite end. Push A side to confirm unload capability. If valve works, problem is electrical.</p>
SLIDE STOP WILL NOT FUNCTION EITHER DIRECTION	<p>Solenoid coils may be burned out. Replace.</p> <p>Solenoid service valves may be closed. Open.</p> <p>Manually actuate solenoid. If slide stop will not move mechanical problems</p>

TROUBLESHOOTING THE LIQUID INJECTION OIL COOLING SYSTEM

SYMPTOM	PROBABLE CAUSES and CORRECTIONS
HIGH OIL TEMPERATURE	<p>Insufficient liquid supply. Check receiver level and pressure drop at injection solenoid.</p> <p>Equalizer pressure too high. Lower.</p> <p>Suction superheat too high. Correct system problem.</p> <p>Thermal valve power head lost charge. Replace.</p> <p>Liquid strainer blocked. Clean.</p> <p>Liquid solenoid coil failed. Replace.</p> <p>Excessive load. Thermovealve undersized. Reduce load or install larger thermovealve.</p>
LOW OIL TEMPERATURE	<p>Equalizing pressure too low. Raise.</p> <p>Suction superheat too low or liquid coming back on compressor. Correct system problem.</p> <p>Low load conditions. Valve oversized. Increase load or use smaller thermovealve.</p>
OIL TEMPERATURE FLUCTUATES	<p>System conditions rapidly fluctuate causing liquid injection system to overrespond. Stabilize system operation.</p>

TROUBLESHOOTING THE DEMAND PUMP SYSTEM

SYMPTOM	PROBABLE CAUSES and CORRECTIONS
PUMP WILL NOT PRODUCE ENOUGH OIL PRESSURE TO START COMPRESSOR	<p>Check pump rotation.</p> <p>Check that service valves are open.</p> <p>Filter cartridges may be blocked. Check PSID across filters.</p> <p>Strainer may be blocked. Clean.</p> <p>Oil pressure regulator set too low or stuck open. Readjust or repair.</p> <p>Pump worn out. Repair or replace.</p>
OIL PRESSURE RAPIDLY DROPS OFF WHEN COMPRESSOR STARTS RESULTS IN COMPRESSOR DIFFERENTIAL ALARM	<p>Main oil injection throttling valve too wide open or oil pressure regulating valve improperly adjusted. Readjust both valves.</p>
OIL PRESSURE FLUCTUATES	<p>Liquid injection overfeeding or refrigerant flood back from system. Make necessary adjustments or corrections</p>
NOISE and VIBRATION	<p>Pump strainer blocked. Clean.</p> <p>Liquid refrigerant overfeed. Adjust liquid injection.</p> <p>Pump worn out. Repair or replace.</p>
GREASE LEAKS FROM VENT PORT IN THE SIDE OF THE PUMP BODY	<p>Normal leakage which will cease after initial operation. Black oil leaking from this vent indicates oil seal wear or failure. If leakage exceeds normal allowable rate of 7 drops per minute, replace seal.</p>
OIL PRESSURE DROPS AS HEAD PRESSURE INCREASES	<p>Normal behavior. Set main oil injection and oil pressure for maximum head pressure condition.</p>
MAIN FILTER PSID IS TOO HIGH	<p>Filters clogged with dirt. Replace.</p> <p>Oil is too cold. Allow oil to warm up and check again.</p> <p>Service valve on filter outlet is partially closed. Open valves fully.</p>

THERMAL EXPANSION VALVES

In situations where system load conditions increase or decrease over extended periods of time and the liquid injection thermal expansion valve is not adequate for the new conditions, an improvement in valve performance may be achieved by increasing or decreasing discharge tube size.

NOTE: DO NOT ATTEMPT TO ADJUST SUPERHEAT ADJUSTMENT STEM ON BOTTOM OF VALVE IN AN EFFORT TO CHANGE THE VALVE'S PERFORMANCE. THIS ADJUSTMENT IS PRESET AT THE FACTORY. ONLY ADJUST 1/4" BLEED VALVE ON EQUALIZING LINE.

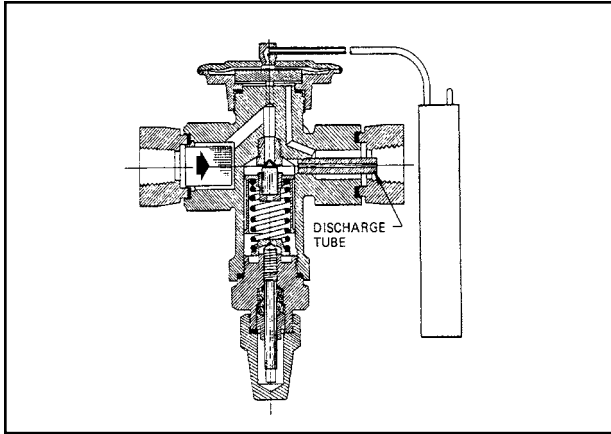

Figure 31 - TYPE D (1-15 TONS) R-717

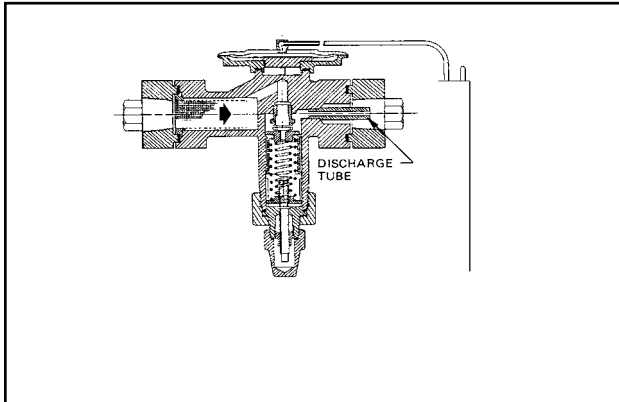

Figure 32 - TYPE A (20-100 TONS) R-717

R-717 TX VALVE SIZES

TX VALVE MODE	PORT SIZE	DISCHARGE TUBE SIZE
DAE - 1	1/16	1/32
DAE - 2	1/16	1/16
DAE - 5	7/64	5/64
DAE - 10	3/16	7/64
DAE - 15	3/16	5/32
AAE - 20	5/16	1/8
AAE - 30	5/16	5/32
AAE - 50	3/8	3/16
AAE - 75	3/8	NONE
AAE - 100	7/16	NONE

JORDAN TEMPERATURE REGULATOR VALVE

The Jordan valve is a high volume, temperature-regulating valve that requires minimal differential across the valve to ensure adequate flow for cooling.

The Jordan valve must be mounted on a horizontal line with the flow arrow pointing toward the direction of flow. However, the valve may be mounted at any angle perpendicular to the horizontal line, including inverted, if necessary.



Sensing Bulb, Vertical Mounting -

When the sensing bulb is to be mounted vertically (pointing down), no special precaution is necessary. If the bulb is to be mounted vertically, in an inverted position, a special capillary is needed because the tip of the sensing bulb is higher than the capillary end.

Sensing Bulb, Horizontal Mounting - When mounting the sensing bulb horizontally it must be mounted so that the word "TOP" which is stamped on the capillary end of the bulb appears accordingly. **NOTE: No angular mounting of the sensing bulb is permitted.**

Adjustment - To increase the oil temperature, increase the spring tension by turning the knurled nut at the base of the spring. To decrease the oil temperature, decrease the spring tension by turning the knurled nut at the base of the spring (see Figure 36).

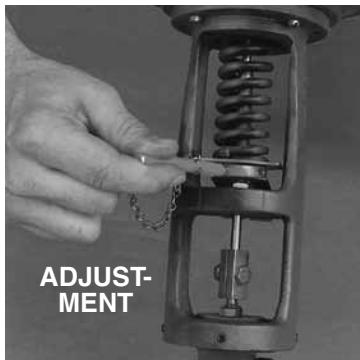

Figure 36

Action - The valve should be set as a reverse acting valve, however there are times when the valve may be set as a direct acting valve. If you experience what seems to be a total absence of oil cooling you will need to check the action of the valve. To check the action you will need to remove the cap-flange and disc-guide.



Figure 37

If the hole in the valve plate is to the left and the slot in the valve disc is on the top this valve is set for Direct Acting (see Figure 37). To change the action of the valve to Reverse Acting simply rotate the valve plate and the valve disc 180° so that the hole on the plate is on the right and the slot on the disk is at the bottom (see Figure 38).

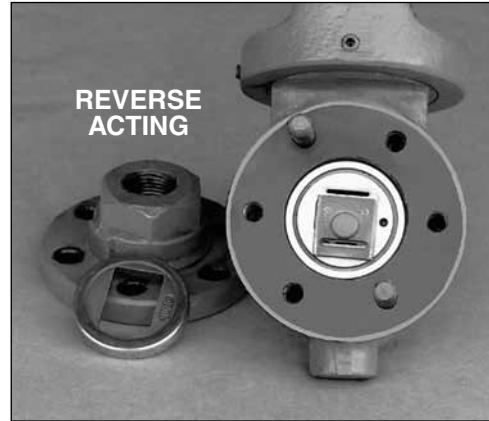

Figure 38

Stroke Adjustment - After the valve action has been changed it may be necessary to make a stroke adjustment. This ensures that the full capacity of the valve is available, if necessary, to keep the oil at the predetermined temperature.

To prepare for a stroke adjustment do the following.

- Remove the disc-guide, valve-disc, and valve-plate.
- Expose the sensing bulb in a vertical position to an ambient temperature of about 80°F.
- Release all spring tension by loosening the knurled nut.

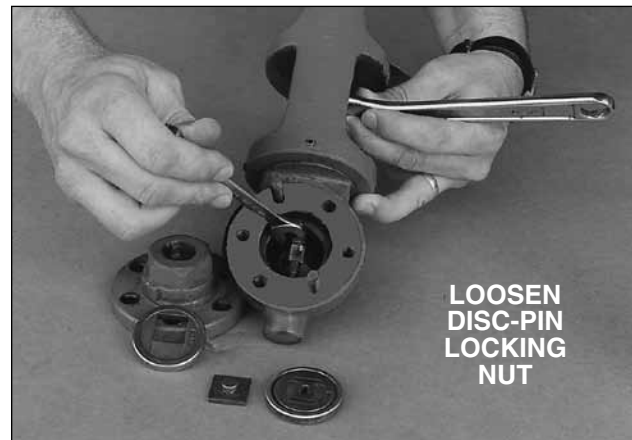

Figure 39

- Loosen the disc-pin locking nut and allow at least 10 minutes for the valve to react (see Figure 39).
- Rotate the disc-pin so that when the valve-plate is installed the bottom of the pin is between the middle and the bottom of the slot.
- Hold the coupling with a wrench and tighten the disc-pin locking nut.
- Install the valve-plate and valve-disk for reverse action (see Figure 38).
- Install the disk-guide and cap-flange.
- Increase the spring tension to about 30% by turning the knurled nut at the base of the spring approximately 20 quarter turns.

Install the valve and adjust the spring tension accordingly to maintain the predetermined oil temperature. The recommended oil temperature is 130°F for ammonia. Check with Frick service for recommended oil temperatures for other refrigerants.

If all of the above steps have been properly performed and the desired oil temperature can not be achieved, contact Johnson Controls-Frick Service.

MOTOR REPLACEMENT

The following procedure is required when a motor is replaced in the field.

1. Verify that main power to the unit is disconnected and tag the switch.
2. Disconnect the coupling from the motor shaft.
3. Remove the two bolts from the motor feet.
4. While supporting the motor with a crane, remove the eight bolts connecting the motor to the tunnel, then remove the motor.
5. Thoroughly clean the motor feet and mounting pads of burrs and other foreign matter to ensure firm seating of the new motor.
6. While supporting the new motor with the crane, install and hand tighten the eight bolts to connect the motor to the tunnel. Then torque the bolts in a star pattern to 250 ft-lb.
7. Then install the two bolts in the in the motor feet and torque them to 250 ft-lb. Remove the crane from motor.
8. Reattach coupling to the motor.

BARE COMPRESSOR REPLACEMENT

The following procedure is required only when a bare compressor is replaced in the field.

1. Verify that main power to the unit is disconnected and tag the switch.
2. Remove all tubing, piping, and wiring that is connected to the compressor.
3. Disconnect the coupling from the motor shaft.
4. While supporting the motor and compressor assembly with a crane, remove the bolts at the motor feet, compressor feet, and separator flange.
5. Thoroughly clean the compressor and motor feet and mounting pads of burrs and other foreign matter to ensure firm seating of the compressor.
6. Clean the discharge flange surfaces on the compressor and separator.
7. Set the assembly on a clean surface and remove the two pins and bolts connecting the compressor to the tunnel and remove the compressor.
8. Assemble the new compressor to the tunnel by inserting the two pins and hand tightening the bolts. then torque the bolts in a star pattern to 250 ft-lb.
9. Install a gasket on the compressor discharge connection of the separator.

10. Using the crane, set the new assembly in place and shim the motor and compressor feet wherer required.

11. Reattach the drive coupling.

12. The shaft alignment must be checked and tolerances verified with the Frick service dept.

13. Complete tubing, piping and wiring per the P & I and wiring diagrams.

SHUTDOWN DUE TO IMPROPER OIL PRESSURE (HIGH STAGE and BOOSTER)

The compressor must not operate with incorrect oil pressure.

1. Refer to CONTROL SETUP - "OIL SETPOINTS DISPLAY" in S90-010 O.

P & I DIAGRAM

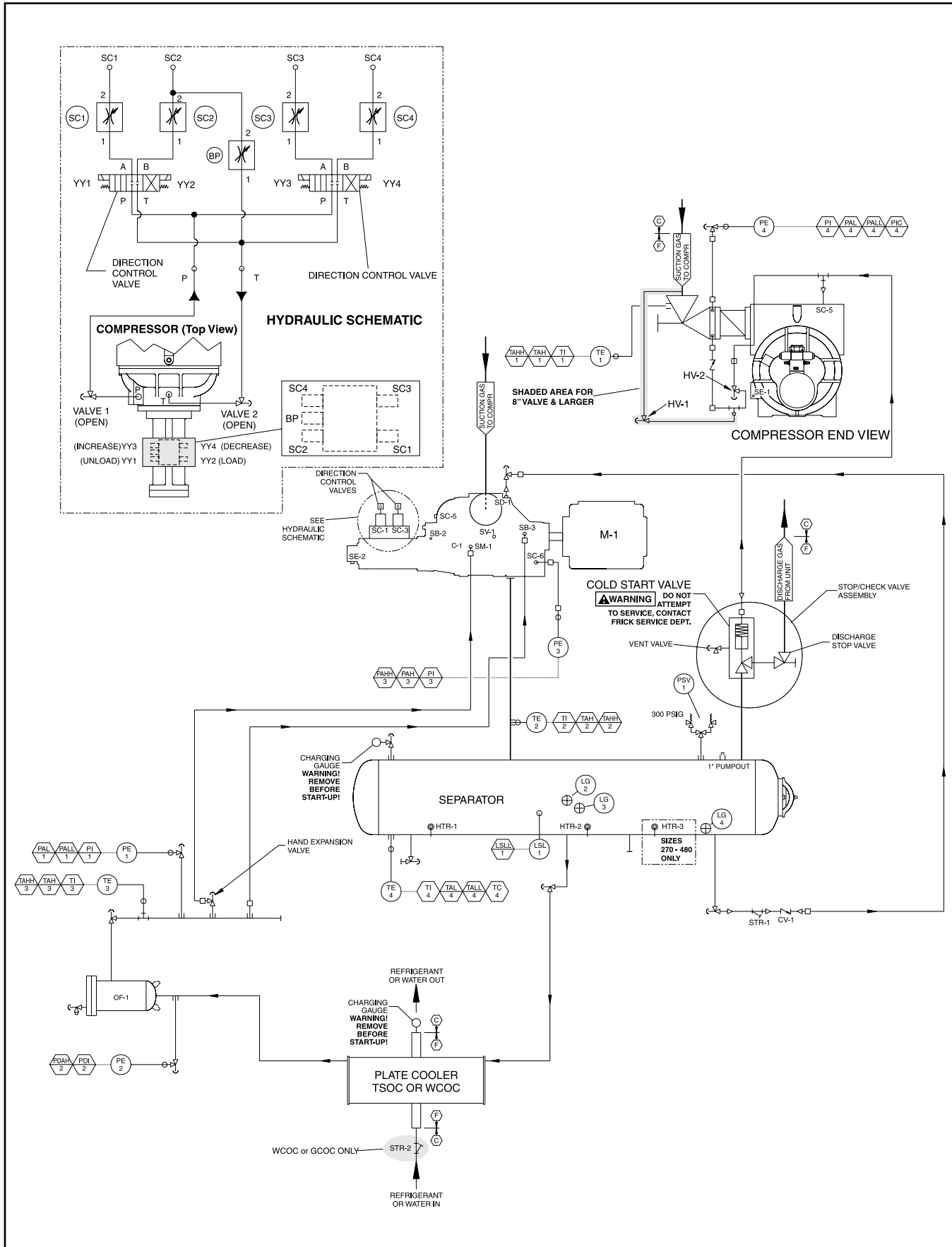

**P & I DIAGRAM - OPTIONAL DUAL OIL FILTERS,
DEMAND OIL PUMP, THERMAL CONTROL VALVE**

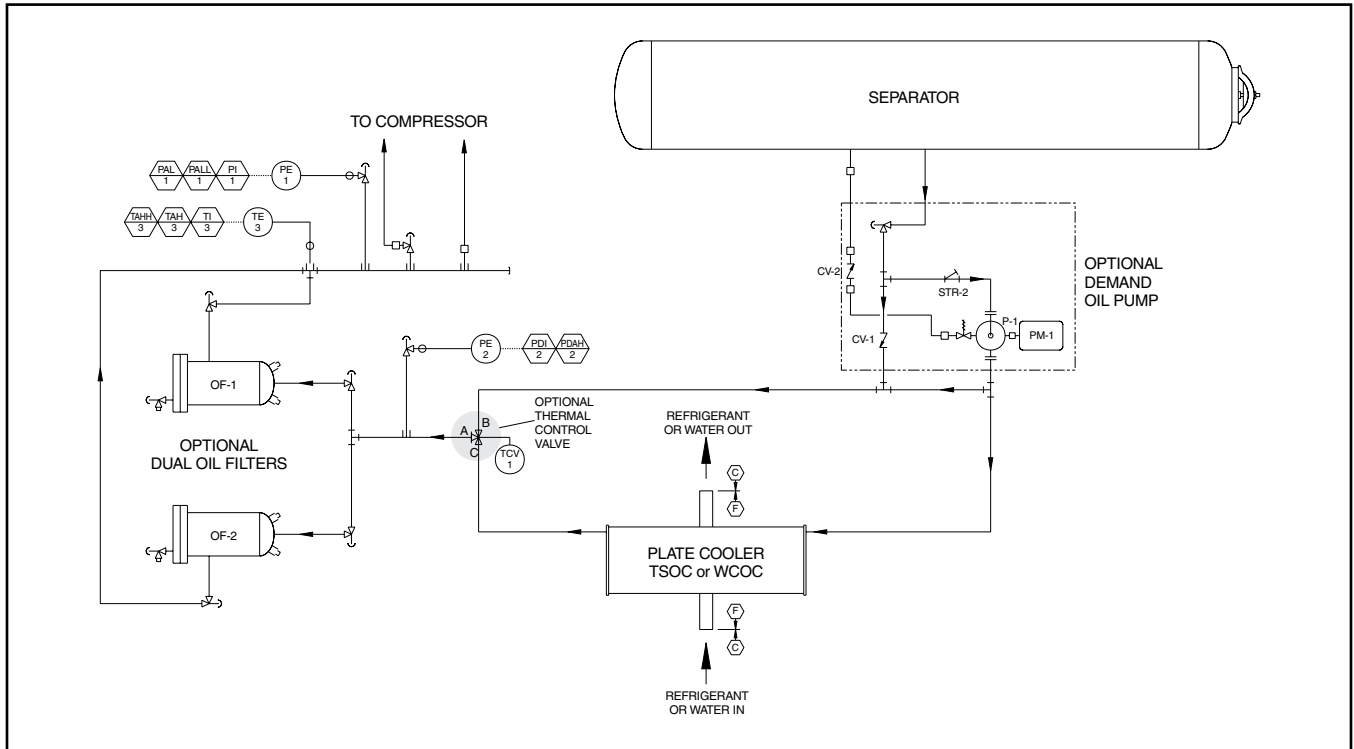

LEGEND (Covers all P & I diagrams in this manual)

C	COMPRESSOR
CV	CHECK VALVE
DP	DISCHARGE PRESSURE
FG	FLOW GLASS
HV	HAND VALVE
HTR	HEATER
LG	LEVEL GLASS
LSLL	SEPARATOR LOW OIL LEVEL SHUTDOWN
M	MOTOR
1MC	MOTOR CONTROL CENTER
2MC	MOTOR CONTROL CENTER
NOS	NO OIL SWITCH
OF	OIL FILTER
OP	OIL PRESSURE
P	DEMAND PUMP
PAH	HIGH DISCHARGE PRESSURE ALARM
PAHH	HIGH DISCHARGE PRESSURE SHUTDOWN
PAL	LOW PRESSURE ALARM
PALL	LOW PRESSURE SHUTDOWN
PDAH	HIGH PRESSURE DIFFERENTIAL ALARM
PDI	PRESSURE DIFFERENTIAL INDICATOR
PDSLL	COMPRESSOR LOW DIFFERENTIAL PRESSURE CUTOUT
PE	PRESSURE TRANSDUCERS
PI	PRESSURE INDICATOR
PIC	PRESSURE INDICATION CONTROLLER
PM	PUMP MOTOR
PS	PRESSURE SWITCH CONTROL
PSV	HIGH PRESSURE SAFETY VALVE
SP	SUCTION PRESSURE
STR	STRAINER
TAH	HIGH TEMPERATURE ALARM
TAHH	HIGH TEMPERATURE SHUTDOWN
TAL	LOW OIL TEMPERATURE ALARM
TALL	LOW OIL TEMPERATURE SHUTDOWN
TC	TEMPERATURE CONTROLLER
TCV	THERMAL CONTROL VALVE
TE	TEMPERATURE ELEMENT
TI	TEMPERATURE INDICATOR
TS	TEMPERATURE SWITCH

TSH	TEMPERATURE SWITCH HIGH ALARM
TW	THERMOWELL
VI	VI CONTROL
SB-2	INLET BEARING & BALANCE PISTON
SB-3	DISCHARGE BEARINGS & SEAL
SC-1	SLIDE VALVE - UNLOAD
SC-2	SLIDE VALVE - LOAD
SC-3	MOVEABLE SLIDE STOP
SC-4	MOVEABLE SLIDE STOP
SC-5	INLET PRESSURE
SC-6	DISCHARGE PRESSURE
SC-7	SEAL WEEPAGE
SC-8	OIL DRAIN CONNECTION
SC-9	INLET HOUSING OIL DRAIN
SC-13	OIL DRAIN CYLINDER
SE-1	ELECTRICAL CONNECTION
SE-2	ELECTRICAL CONNECTION
SL-1	LIQUID INJECTION LOW VI
SL-2	LIQUID INJECTION HIGH VI
SM-1	MAIN OIL INJECTION
SV-1	VAPOR INJECTION TONGUE & GROOVE
SD-1	COALESCER BLEED STR THD O-RING PORT
TW-1	THERMOWELL
PRESSURE TRANSDUCERS INDICATE:	
PE-1	OIL PRESSURE (MANIFOLD)
PE-2	OIL PRESSURE BEFORE FILTER
PE-3	DISCHARGE PRESSURE
PE-4	SUCTION PRESSURE
TEMPERATURE PROBES INDICATE:	
TE-1	SUCTION GAS TEMPERATURE
TE-2	DISCHARGE GAS TEMPERATURE
TE-3	LUBE OIL TEMPERATURE
TE-4	SEPARATOR OIL TEMPERATURE
SOLENOID VALVE FUNCTION:	
YY-1	ENERGIZE UNLOAD SLIDE VALVE
YY-2	ENERGIZE LOAD SLIDE VALVE
YY-3	ENERGIZE INCREASE VOLUME RATIO
YY-4	ENERGIZE DECREASE VOLUME RATIO

P & I DIAGRAM, LIQUID INJECTION – SINGLE PORT

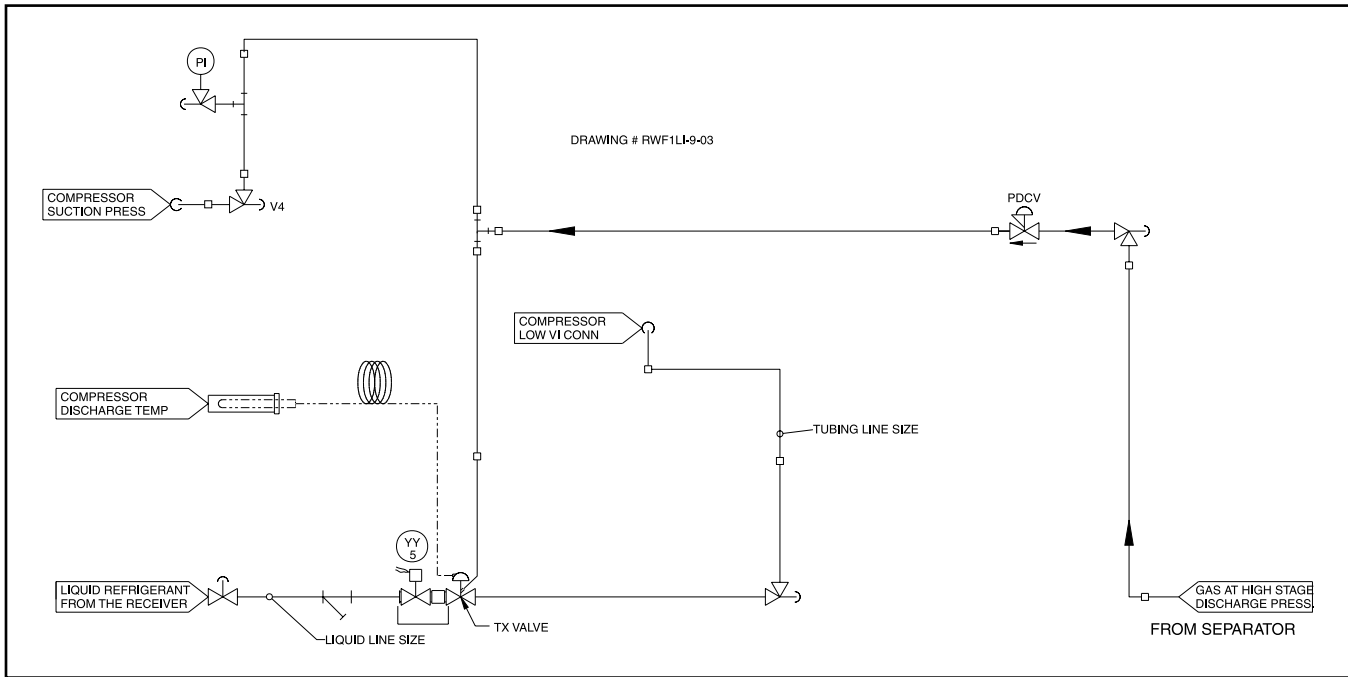

P & I DIAGRAM, LIQUID INJECTION – DUAL PORT

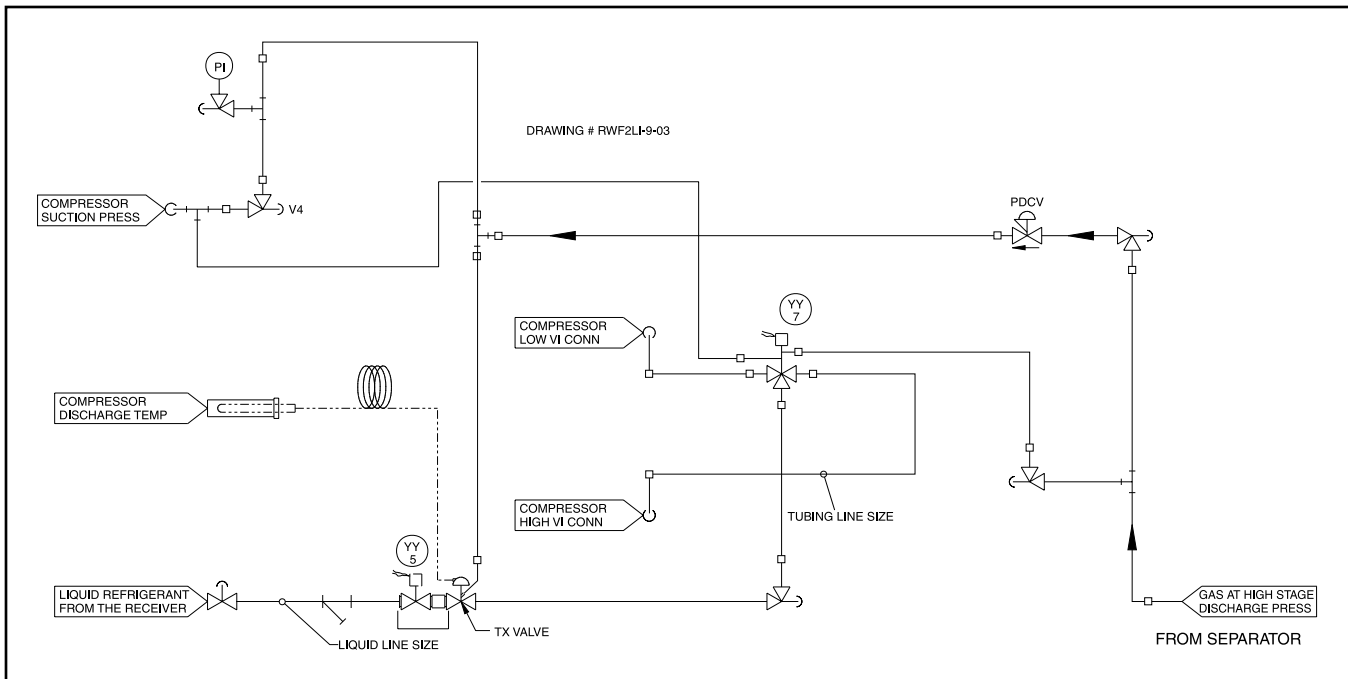

P & I DIAGRAM, LIQUID INJECTION – BOOSTER

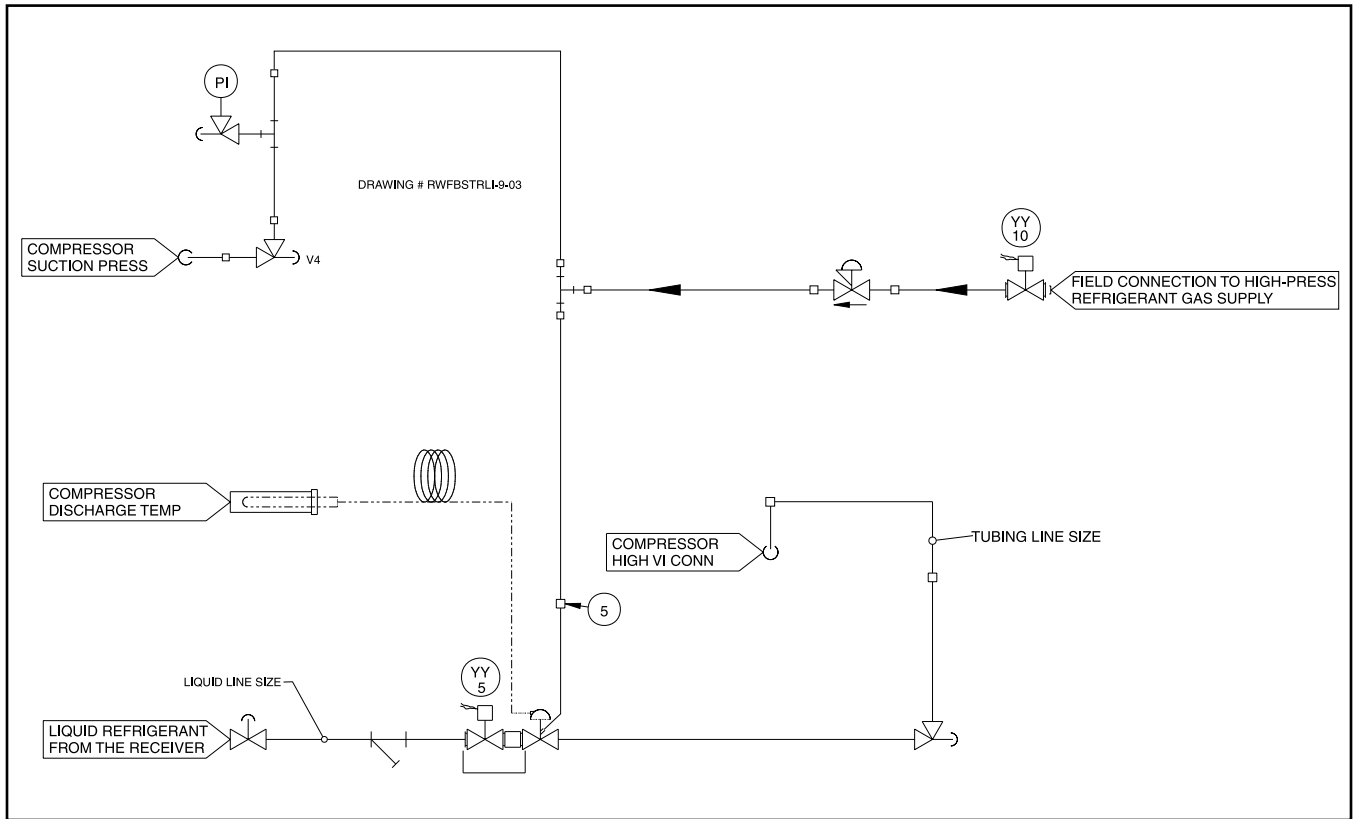

WIRING HARNESS (Quantum 4) - External Transducers for Board #1

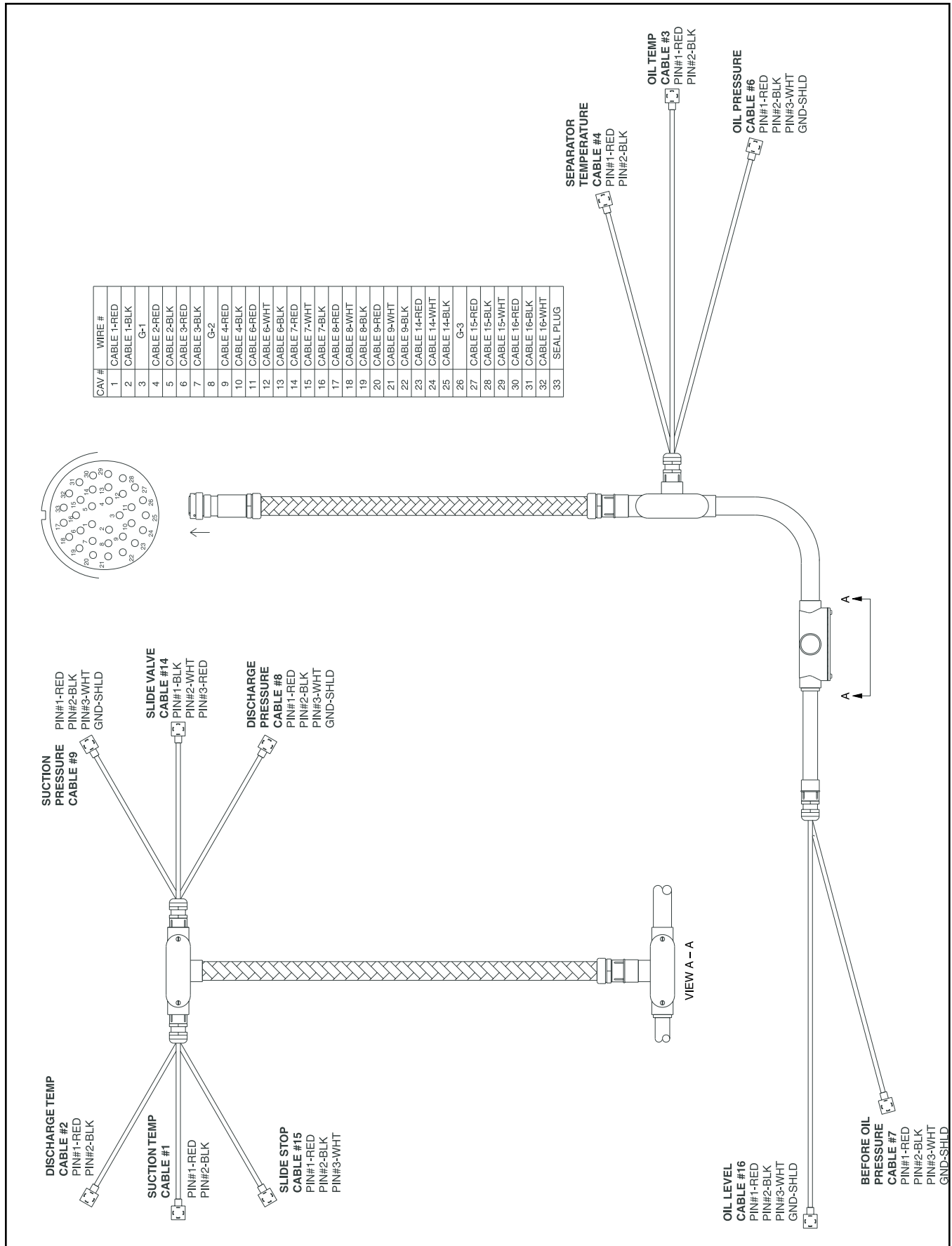

WIRING HARNESS (Quantum 4A) - External Transducers for Board #1

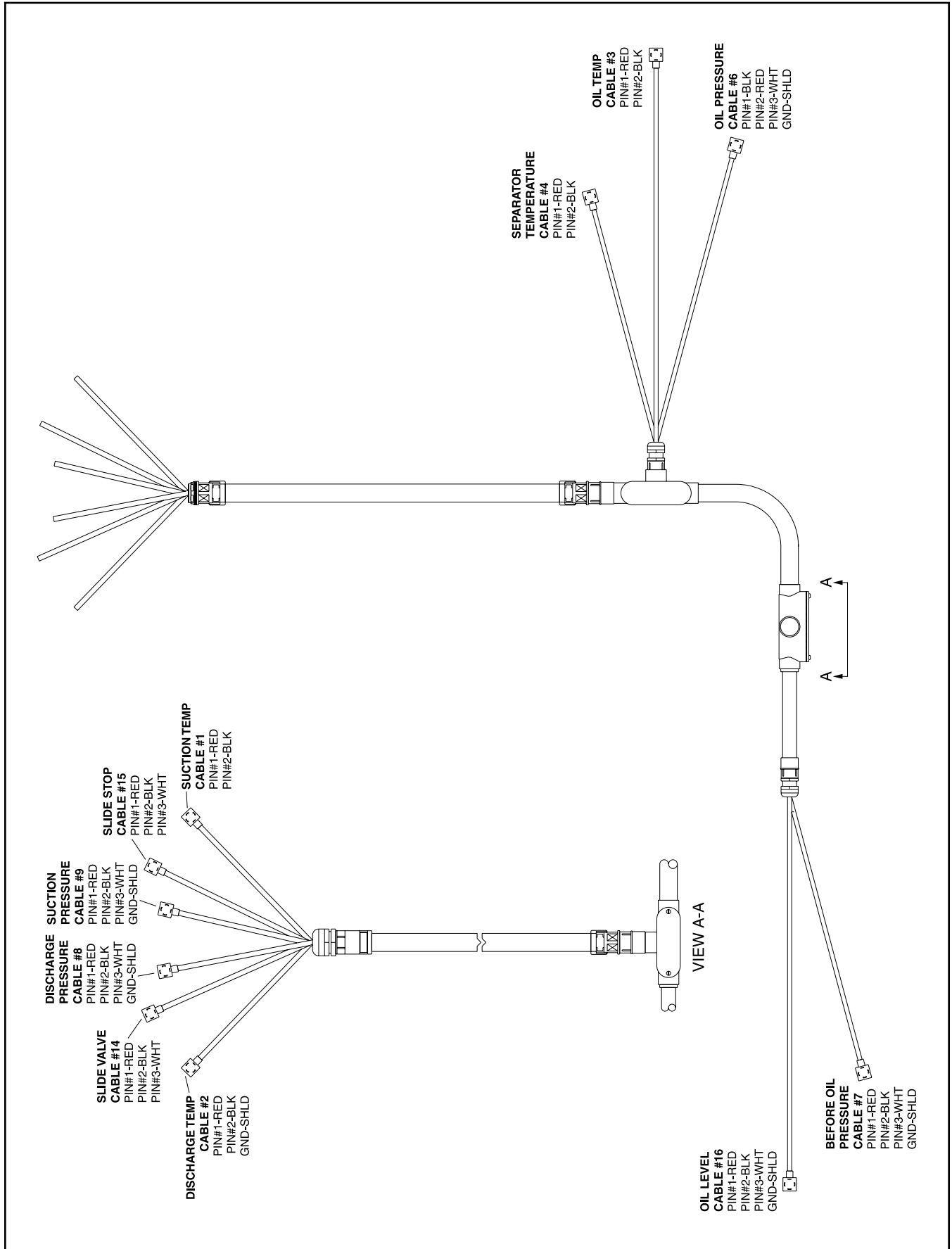

WIRING HARNESS (Quantum 4) - External AC to Heaters and Valves

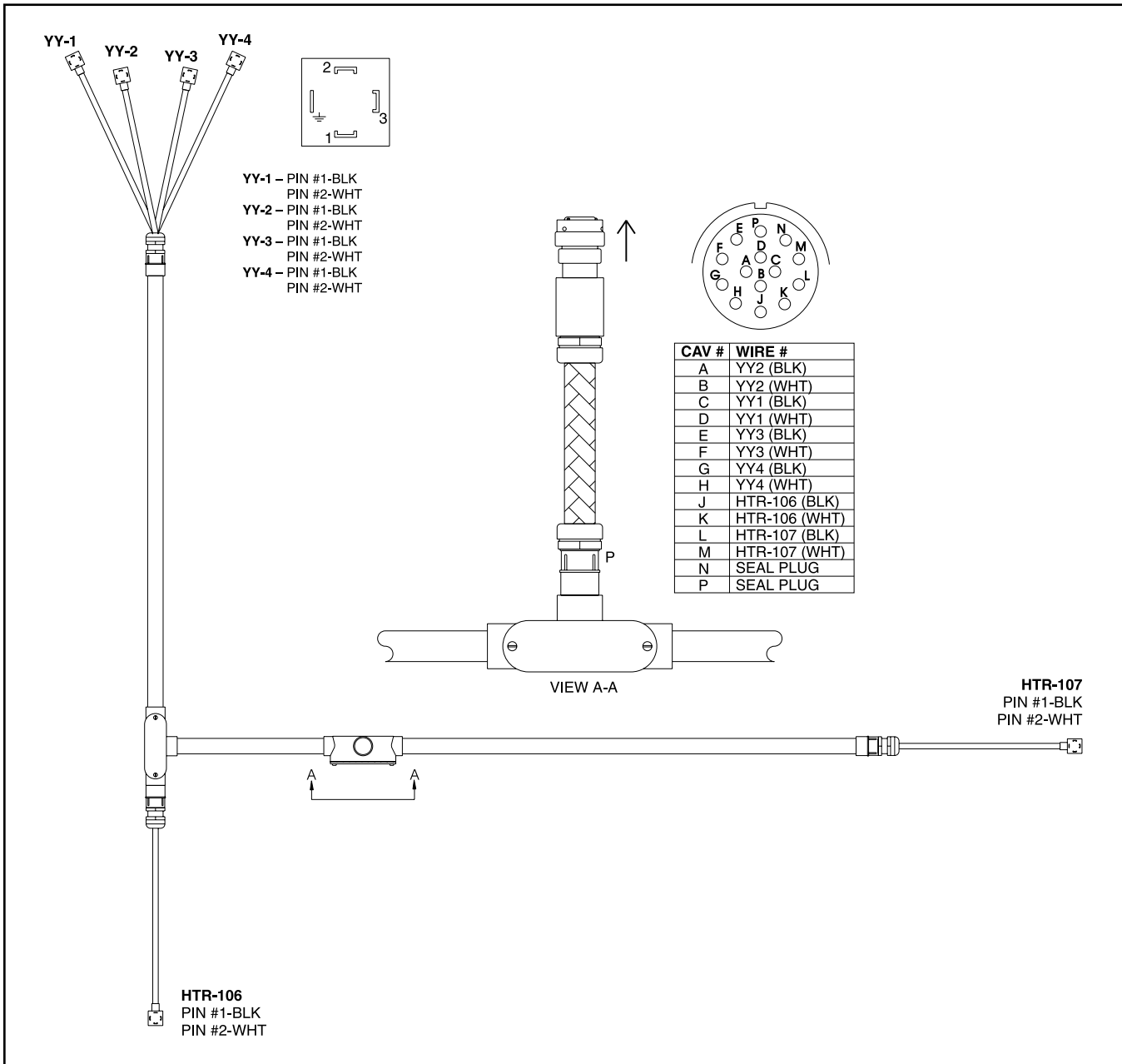

WIRING HARNESS (Quantum 4A) - External AC to Heaters and Valves

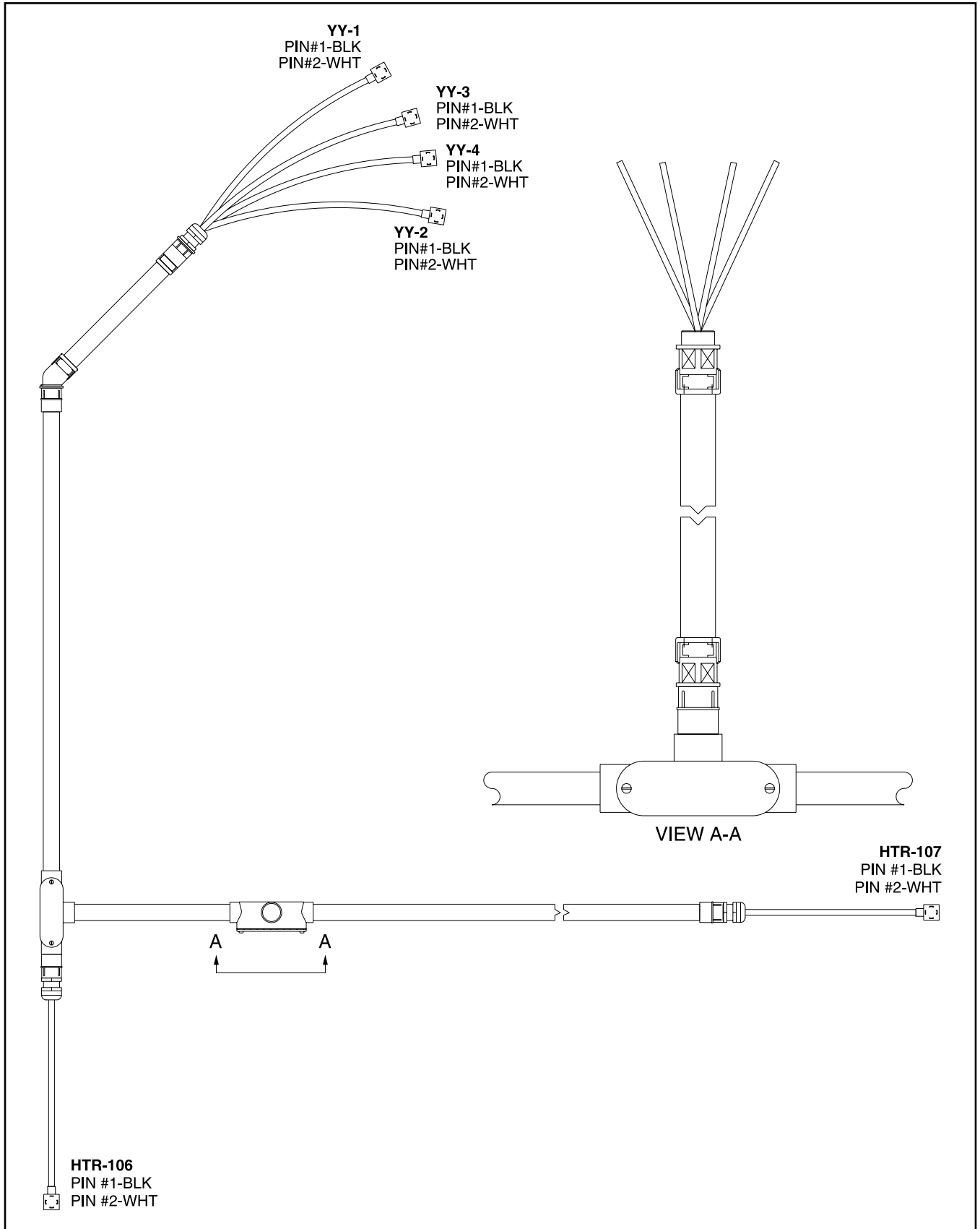

WIRING HARNESS (Quantum 4 only) - Internal Analog Board #1

CAV NO.	WIRE NO.
1	1.1.1
2	1.1.2
3	G-1
4	1.1.4
5	1.1.5
6	1.2.1
7	1.2.2
8	G-2
9	1.2.4
10	1.2.5
11	1.3.4
12	1.3.5
13	1.3.6
14	1.4.1
15	1.4.2
16	1.4.3
17	1.4.4
18	1.4.5
19	1.4.6
20	1.5.1
21	1.5.2
22	1.5.3
23	1.7.4
24	1.7.5
25	1.7.6
26	G-3
27	1.8.1
28	1.8.3
29	1.8.2
30	1001
31	1000
32	1002
33	SEAL PLUG

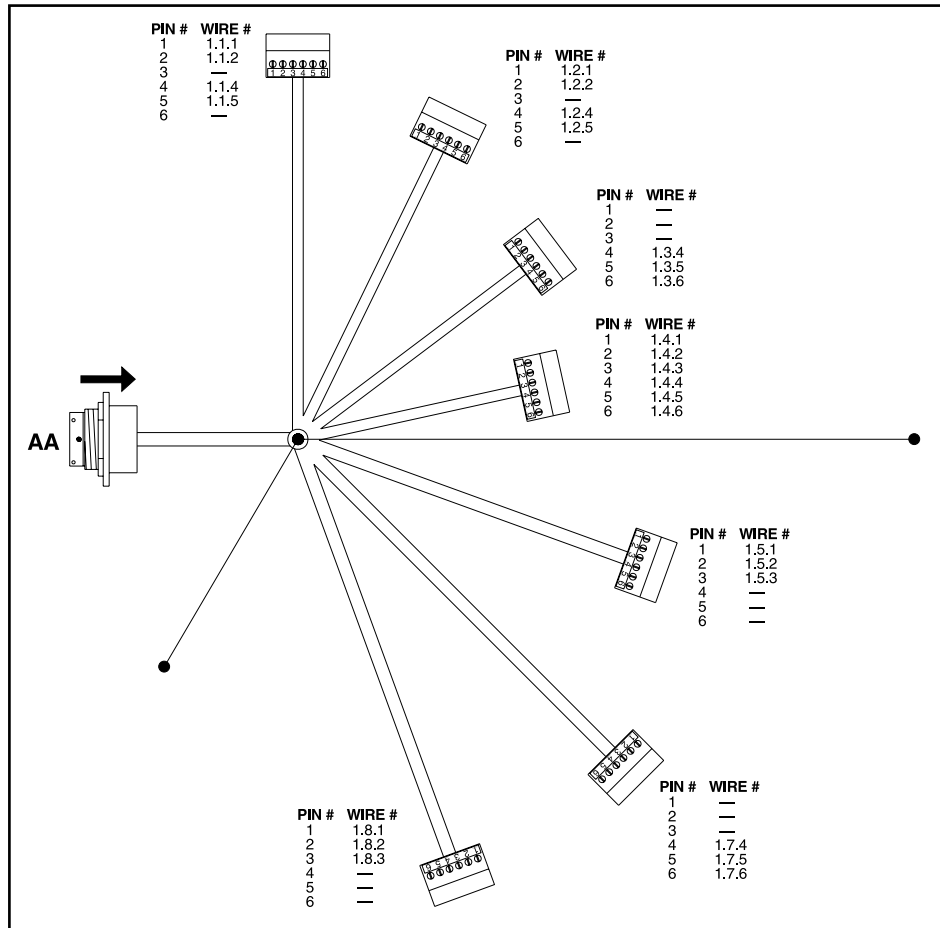

WIRING HARNESS - AC Conduit - Quantum to DBS Panel

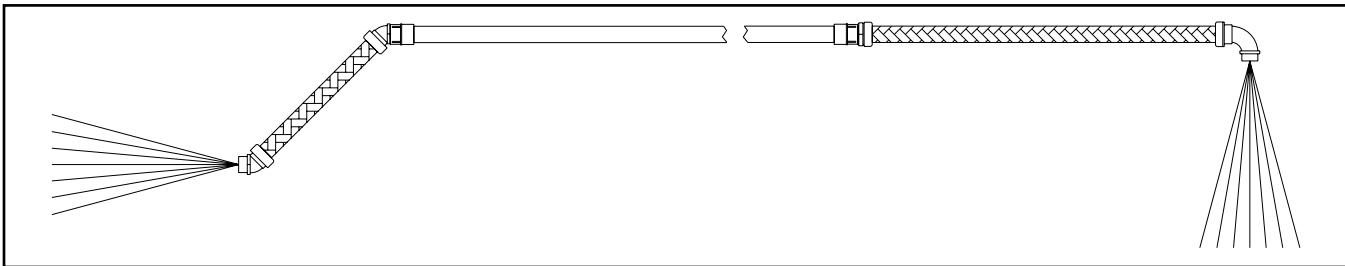

WIRING HARNESS (Quantum 4 only) - Internal AC to Heaters and Valves

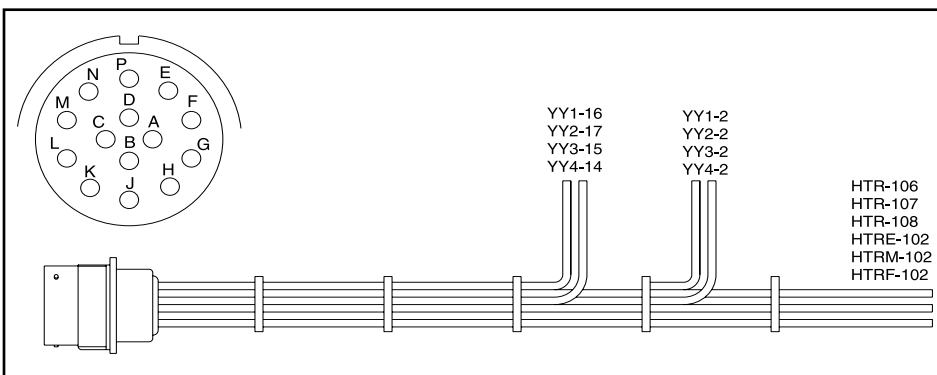

CAV NO.	WIRE NO.
A	YY2-17
B	YY2-2
C	YY1-16
D	YY1-2
E	YY3-15
F	YY3-2
G	YY4-14
H	YY4-2
J	HTR-106
K	HTR-102
L	HTR-107
M	HTR-102
N	HTR-108
P	HTR-102

PROPER INSTALLATION OF ELECTRONIC EQUIPMENT IN AN INDUSTRIAL ENVIRONMENT

In today's refrigeration plants, electronic controls have found their way into almost every aspect of refrigeration control. Electronic controls have brought to the industry more precise control, improved energy savings, and operator conveniences. Electronic control devices have revolutionized the way refrigeration plants operate today.

The earlier relay systems were virtually immune to radio frequency interference (RFI), electromagnetic interference (EMI), and ground loop currents. Therefore installation and wiring were of little consequence and the wiring job consisted of hooking up the point-to-point wiring and sizing the wire properly. In an electronic system, improper installation will cause problems that may outweigh the benefits of electronic control. Electronic equipment is susceptible to RFI, EMI, and ground loop currents which can cause equipment shutdowns, processor memory and program loss, as well as erratic behavior and false readings. Manufacturers of industrial electronic equipment take into consideration the effects of RFI, EMI, and ground loop currents and incorporate protection of the electronics in their designs. However, these design considerations do not make the equipment immune, so manufacturers require that certain installation precautions be taken to protect the electronics from these effects. All electronic equipment must be viewed as sensitive instrumentation and therefore requires careful attention to installation procedures. These procedures are well known to instrumentation, networking, and other professions but may not be followed by general electricians.

There are a few basic practices that if followed, will minimize the potential for problems resulting from RFI, EMI and/or ground loop currents. The National Electric Code (NEC) is a guideline for safe wiring practices, but it does not necessarily deal with procedures used for electronic control installation. Use the following procedures for electronic equipment installation. These procedures do not override any rules by the NEC, but are to be used in conjunction with the NEC code and any other applicable codes.

With exclusion of the three phase wire sizing, Frick drawing 649D4743 should be used as a reference for properly sizing control wires and other wiring specifications.

Throughout this document the term Electronic Control Panel is used to refer to the microprocessor mounted on the compressor package or a Central Control System panel.

NOTE: It is very important to read the installation instructions thoroughly before beginning the project. Make sure you have drawings and instructions with your equipment. If not, call the manufacturer and request the proper instructions and drawings. Every manufacturer of electronic equipment should have a knowledgeable staff, willing to answer your questions or provide additional information. Following correct wiring procedures will ensure proper installation and consequently, proper operation of your electronic equipment.

WIRE SIZING

Control power supply wires should be sized one size larger than required for amperage draw to reduce instantaneous voltage dips caused by large loads such as heaters, contactors, and solenoids. These sudden dips in voltage can cause the electronic control panel, whether it is a microprocessor, a computer, or a PLC, to malfunction momentarily or cause a complete reset of the control system. If the wire is

loaded to its maximum capacity, the voltage dips are much larger, and the potential of a malfunction is very high. If the wire is sized one size larger than required, the voltage dips are smaller than in a fully loaded supply wire and the potential for malfunction is much lower. The NEC code book calls for specific wire sizes to be used based on current draw. An example of this would be to use #14 gauge wire for circuits up to 15 amps or #12 gauge wire for circuits of up to 20 amps. Therefore, when connecting the power feed circuit to an electronic control panel, use #12 gauge wire for a maximum current draw of 15 amp and #10 wire for a maximum current draw of 20 amp. Use this rule of thumb to minimize voltage dips at the electronic control panel.

VOLTAGE SOURCE

Selecting the voltage source is extremely important for proper operation of electronic equipment in an industrial environment. Standard procedure for electronic instrumentation is to provide a clean, isolated, separate-source voltage in order to prevent EMI (from other equipment in the plant) from interfering with the operation of the electronic equipment. Connecting electronic equipment to a breaker panel (also known as lighting panels or utility panels) subjects the electronic equipment to noise generated by other devices connected to the breaker panel. This noise is known as electromagnetic interference (EMI). EMI flows on the wires that are common to a circuit. EMI cannot travel easily through transformers and therefore can be isolated from selected circuits. Use a control power transformer of the proper VA rating, usually provided in the compressor drive motor starter, to isolate the electronic control panel from other equipment in the plant that generate EMI. See Figure 40.

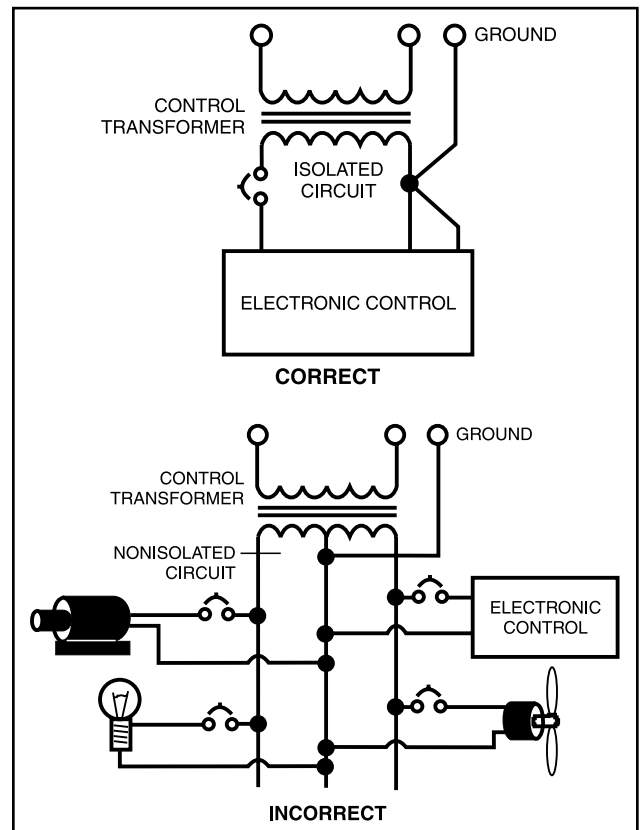

Figure 40

GROUNDING

Grounding is the most important factor for successful operation and is typically the most overlooked. The NEC states that control equipment may be grounded by using the rigid conduit as a conductor. This worked for the earlier relay systems, but it is in no way acceptable for electronic control equipment. Conduit is made of steel and is a poor conductor relative to an insulated stranded copper wire. Electronic equipment reacts to very small currents and must have a proper ground in order to operate properly; therefore, stranded copper grounds are required for proper operation.

For proper operation, the control power ground circuit must be a single continuous circuit of the proper sized insulated stranded conductor, from the electronic control panel to the plant supply transformer (Figure 41). Driving a ground stake at the electronic control may also cause additional problems since other equipment in the plant on the same circuits may ground themselves to the ground stake causing large ground flow at the electronic control panel. Also, running multiple ground conductors into the electronic control panel from various locations can create multiple potentials resulting in ground loop currents. A single ground wire (10 AWG or 8 AWG) from the electronic control panel, that is bonded to the control power neutral at the secondary side of the control power transformer in the starter and then to the 3-phase ground point, will yield the best results.

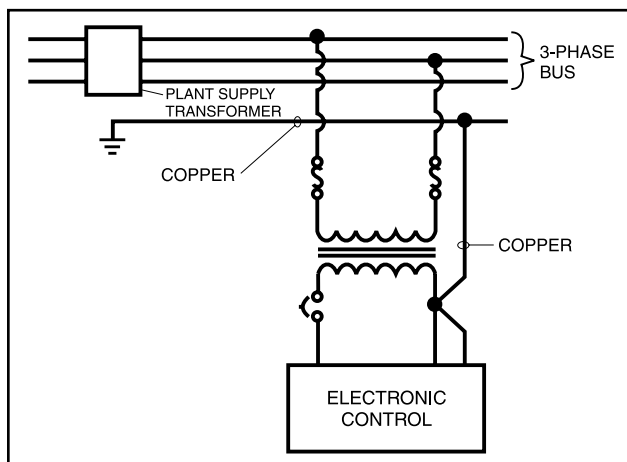

Figure 41

NOTE: Structural grounding can also result in multiple ground potentials and is also a relatively poor conductor. Therefore, this is not an acceptable method for proper operation of electronic equipment.

There must be a ground for the three-phase power wiring. This must be sized in accordance to the NEC and any local codes relative to the highest rated circuit overload protection provided in the circuit. The manufacturer may require a larger ground conductor than what is required by the NEC for proper steering of EMI from sensitive circuits. This conductor must also be insulated to avoid inadvertent contact at multiple points to ground, which could create Ground Loops. In many installations that are having electronic control problems, this essential wire is usually missing, is not insulated, or improperly sized.

NEC size ratings are for safety purposes and not necessarily for adequate relaying of noise (EMI) to earth ground to avoid possible interference with sensitive equipment. Therefore sizing this conductor 1 – 2 sizes larger than required by code will provide better transfer of this noise.

Frick requires that the ground conductor meet the following requirements be:

- Stranded Copper
- Insulated
- One size larger than NEC requirements for conventional starters
- Two sizes larger than NEC requirements for VFD starters
- Conduit must be grounded at each end
- This circuit must be complete from the motor to the starter continuing in a seamless manner back to the plant supply transformer (power source).

For Direct Coupled, Package Mounted Starters, the ground between the motor and the starter may need to be made externally (Figure 42). The connection on the starter end must be on the starter side of the vibration isolators. Be certain the connection is metal to metal. Paint may need to be removed to ensure a proper conductive circuit. The use of counter-sunk star washers at the point of connection at each end will maximize metal to metal contact.

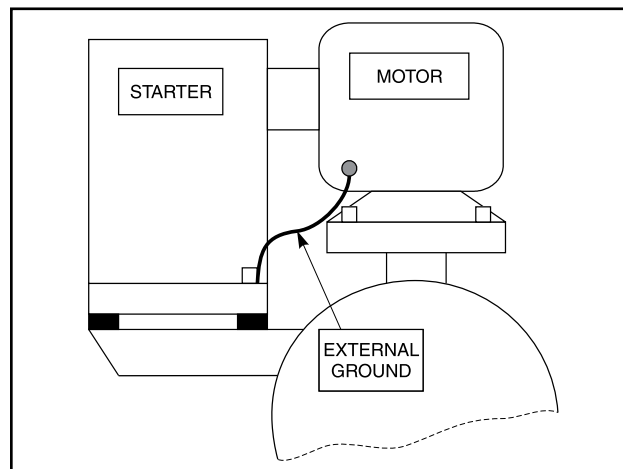

Figure 42

VFD APPLICATIONS

The primary ground conductor that accompanies the three-phase supply must be stranded copper, insulated and two sizes larger than the minimum required by the NEC or any other applicable codes. This is necessary due to the increased generation of EMI which is a characteristic of a VFD output to the motor when compared to a conventional starter.

For VFD applications, isolation of the control power, analog devices, and communications ground from the 3-phase ground within the starter and the electronic control panel may be necessary. This is due to the higher noise (RFI/EMI) levels generated between the VFD output and the motor, relative to a conventional starter. If these grounds are left coupled by a common back-plate in the starter/drive, this noise can

be direct coupled to the control power, analog device, and communications grounding and may cause unexplained behavior and possible damage to components.

To install correctly, run a separate, properly sized (10 or 8 AWG typically) insulated ground along with and taken to ground with, the 3-phase ground at the 3-phase supply transformer (plant). This will require that the 3-phase ground and the control power ground be electrically isolated except for the connection at the plant supply transformer.

This style of grounding should steer the noise (EMI/RFI) to earth ground, reducing the potential for it to affect the sensitive equipment, which could occur if the grounds were left coupled. **NOTE: If all other recommendations for grounding are followed, this process should not be necessary.**

CONDUIT

All national and local codes must be followed for conduit with regard to materials, spacing and grounding. In addition, **Johnson Controls-Frick requirements must be followed where they exceed or match national or local codes. Conversely, there is no allowance for any practices that are substandard to what is required by national or local codes.**

Johnson Controls-Frick conduit requirements:

- For *variable frequency drives* (VFDs) of any type, threaded metallic or threaded PVC-coated metallic is required for both the power feed (line side) from the source and between the VFD output and the motor (load side).
- PVC conduit is acceptable **only** when *VFD rated cable* of the proper conductor size and ground is used. This applies to both the line side and load side of the drive. When VFD rated cable is not used, threaded metallic or threaded PVC-coated metallic must be used.
- When threaded metallic or threaded PVC-coated metallic is used, it must be grounded at both ends.
- When not required to be in metal or other material by national or local codes, conduits for the power feed (3-phase) of constant speed starters may be PVC.
- When not required to be in metal or other material by national or local codes, conduits between a constant speed starter and the motor (3-phase) may be PVC.
- Any unshielded control voltage, signal, analog, or communication wiring that does not maintain 12 inches of separation from any 3-phase conductors for every 33 feet (10 meters) of parallel run must be in metal conduit which will be grounded.

Separation: (0-33 feet, 0-10 meters – 12 inches, .3 meters), (33-66 feet, 10-20 meters – 24 inches, .6 meters)

- Since PVC conduit does absolutely nothing to protect lower voltage lines from the magnetic field effects of higher voltage conductors, running either the lower or the higher voltage lines in PVC, does not reduce these requirements on separation. Only running in metal conduit can relieve these requirements.
- Due to the level of EMI that can be induced onto lower voltage lines when running multiple feeders in a trench, control power, communications, analog, or signal wiring cannot be run in trenches that house multiple conduits/

electrical ducts carrying 3-phase power to starters/vfd or motors.

- Control power, communications, analog, or signal wiring should be run overhead (preferred) or in a separate trench. If these lines are not in threaded metallic or threaded PVC-coated metallic, abiding by the separation requirements noted above is necessary.
- Though not recommended, if cable trays are used, *metallic* dividers must be used for separation of conductors of unlike voltages and types (AC or DC).

NOTE: When in doubt contact the factory or use threaded metallic or threaded PVC coated metallic conduit.

WIRING PRACTICES

Do not mix wires of different voltages in the same conduit. An example of this would be the installation of a screw compressor package where the motor voltage is 480 volts and the electronic control panel power is 120 volts. The 480 volt circuit must be run from the motor starter to the motor in its own conduit. The 120 volt circuit must be run from the motor starter control transformer to the electronic control panel in its own separate conduit. If the two circuits are run in the same conduit, transients on the 480 volt circuit will be induced onto the 120 volt circuit causing functional problems with the electronic control panel. Metallic dividers must be used in wire way systems (conduit trays) to separate unlike voltages. The same rule applies for 120 volt wires and 220 volt wires. Also, never run low voltage wires for DC analog devices or serial communications in the same conduit with any AC wiring including 120 volt wires. See Figure 43.

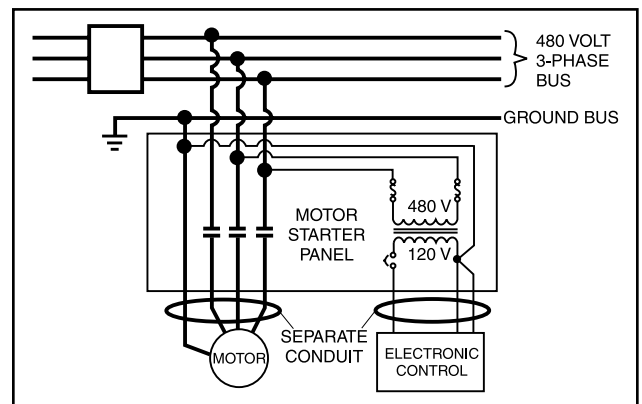

Figure 43

Never run any wires through an electronic control panel that do not relate to the function of the panel. Electronic control panels should never be used as a junction box. These wires may be carrying large transients that will interfere with the operation of the control panel. **An extreme example of this would be to run 480 volts from the starter through the electronic control panel to an oil pump motor.**

When running conduit to the electronic control panel, use the access holes (knockouts) provided by the manufacturer. These holes are strategically placed so that the field wiring does not interfere with the electronics in the panel. Never allow field wiring to come in close proximity with the controller boards since this will almost always cause problems.

Do not drill into an electronic control panel to locate conduit connections. You are probably not entering the panel where the manufacturer would like you to since most manufacturers recommend or provide prepunched conduit connections. You may also be negating the NEMA rating of the enclosure. Drilling can cause metal filings to land on the electronics and create a short circuit when powered is applied. If you must drill the panel, take the following precautions:

- First, call the panel manufacturer before drilling into the panel to be sure you are entering the panel at the right place.
- Take measures to avoid ESD (electrostatic discharge) to the electronics as you prep the inside of the Electronic control panel. This can be done by employing an antistatic wrist band and mat connected to ground.
- Cover the electronics with plastic and secure it with masking or electrical tape.
- Place masking tape or duct tape on the inside of the panel where you are going to drill. The tape will catch most of the filings.
- Clean all of the remaining filings from the panel before removing the protective plastic.

When routing conduit to the top of an electronic control panel, condensation must be taken into consideration. Water can condense in the conduit and run into the panel causing catastrophic failure. Route the conduit to the sides or bottom of the panel and use a conduit drain. If the conduit must be routed to the top of the panel, use a sealable conduit fitting which is poured with a sealer after the wires have been pulled, terminated, and the control functions have been checked. A conduit entering the top of the enclosure must have a NEMA-4 hub type fitting between the conduit and the enclosure so that if water gets on top of the enclosure it cannot run in between the conduit and the enclosure. This is extremely important in outdoor applications.

NOTE: It is simply NEVER a good practice to enter through the top of an electronic control panel or starter panel that does not already have knockouts provided. If knockouts are not provided for this purpose it is obvious this is not recommended and could VOID WARRANTY.

Never add relays, starters, timers, transformers, etc. inside an electronic control panel without first contacting the manufacturer. Contact arcing and EMI emitted from these devices can interfere with the electronics. Relays and timers are routinely added to electronic control panels by the manufacturer, but the manufacturer knows the acceptable device types and proper placement in the panel that will keep interference to a minimum. If you need to add these devices, contact the manufacturer for the proper device types and placement.

Never run refrigerant tubing inside an electronic control panel. If the refrigerant is ammonia, a leak will totally destroy the electronics.

If the electronic control panel has a starter built into the same panel, be sure to run the higher voltage wires where indicated by the manufacturer. EMI from the wires can interfere with the electronics if run too close to the circuitry.

Never daisy-chain or parallel-connect power or ground wires to electronic control panels. Each electronic control panel must have its own control power supply and ground wires back to the power source (Plant Transformer). Multiple electronic control panels on the same power wires create current surges in the supply wires, which may cause controller malfunctions. Daisy-chaining ground wires, taking them to ground at each device, allows ground loop currents to flow between electronic control panels which also causes malfunctions. See Figure 44.

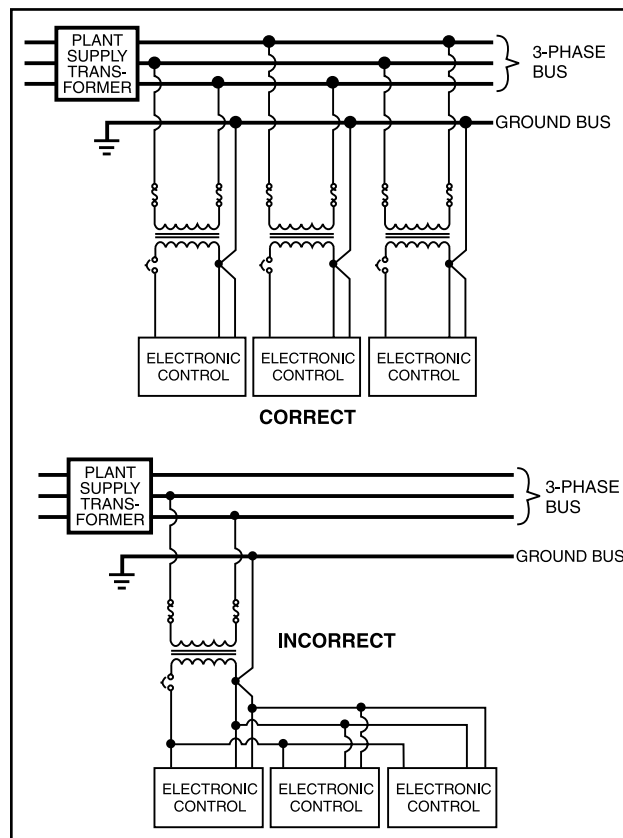

Figure 44

COMMUNICATIONS

The use of communications such as serial and ethernet in industrial environments are commonplace. The proper installation of these networks is as important to the proper operation of the communications as all of the preceding practices are to the equipment.

Serial communications cable needs to be of the proper gauge based on the total cable distance of the run. Daisy-chaining is the only acceptable style of running the communications cable. While Star Networks may use less cable, they more often than not cause problems and interruptions in communications, due to varying impedances over the varying lengths of cable. Ground or drain wires of the communications cable are to be tied together at each daisy-chain connection and only taken to ground in the central control system panel.

It is important to carefully consider the type of cable to be used. Just because a cable has the proper number of conductors and is shielded does not mean it is an acceptable cable. Frick recommends the use of Belden #9829 for RS-422 communications and Belden # 9841 for RS-485 up to 2000 feet (600 Meters) total cable length. Refer to Frick drawing 649D4743 for more detail

Comm Port Protection: Surge suppression for the comm ports may not be the best method, since suppression is required to divert excess voltage/current to ground. Therefore, the success of these devices is dependent on a good ground (covered earlier in this section). This excess energy can be quite high and without a proper ground, it will access the port and damage it.

Isolation or Optical Isolation is the preferred comm port protection method. With optical isolation, there is no continuity between the communications cable and the comm port. There is no dependence on the quality of the ground. Be sure to know what the voltage isolation value of the optical isolator is before selecting it. These may range from 500 to 4000 Volts.

Frick Optical Isolation Kits are offered under part number 639C0133G01. One kit is required per comm port.

UPS POWER AND QUANTUM™LX PANELS

Johnson Controls, Inc. does not advise nor support the use of uninterrupted power supply systems for use with the Quantum™LX panel. With a UPS system providing shutdown protection for a Quantum panel, the panel may not see the loss of the 3-phase voltage on the motor because the UPS may prevent the motor starter contactor from dropping out. With the starter contactor still energized, the compressor auxiliary will continue to feed an “okay” signal to the Quantum™LX panel. This may allow the motor to be subjected to the fault condition on the 3-phase bus.

A couple of fault scenarios are: 1. The 3-phase bus has power “on” and “off” in a continuous cycle manner which may cause the motor to overheat due to repeated excessive in-rush current experiences. 2. The motor cycling may damage the coupling or cause other mechanical damage due to the repeated high torque from rapid sequential motor “bumps.” 3. Prolonged low voltage may cause the motor to stall and possibly overheat before the motor contactor is manually turned off.

Under normal conditions, the loss of 3-phase power will shut down the Quantum™LX panel and it will reboot upon proper power return. If the panel was in “Auto,” it will come back and return to running as programmed. If the unit was in “Remote,” the external controller will re-initialize the panel and proceed to run as required. If the panel was in “Manual” mode, the compressor will have to be restarted manually after the 3-phase bus fault/interruption has been cleared / restored.

If the local power distribution system is unstable or prone to problems there are other recommendations to satisfy these problems. If power spikes or low or high line voltages are the problem, then a constant voltage (CV) transformer with a noise suppression feature is recommended. Johnson Controls, Inc. can provide these types of transformers for this purpose. Contact Johnson Controls for proper sizing (VA Rating) based on the requirement of the job. If a phase loss occurs, then you will typically get a high motor amp shutdown. If the problem continues, an analysis of the facility's power supply quality may be necessary.

RWF II COMPRESSOR PRESTART CHECKLIST

The following items **MUST** be checked and completed by the installer prior to the arrival of the Frick Field Service Supervisor. Details on the checklist can be found in this manual. Certain items on this checklist will be reverified by the Frick Field Service Supervisor prior to the actual start-up.

Mechanical Checks

- Confirm that motor disconnect is open
- Isolate suction pressure transducer
- Pressure test and leak check unit
- Evacuate unit
- Remove compressor drive coupling guard
- Remove coupling center and **DO NOT reinstall** (motor rotation must be checked without center)
- Check for correct position of all hand, stop, and check valves **PRIOR** to charging unit with **OIL** or **REFRIGERANT**
- Charge unit with correct type and quantity of oil
- Lubricate electric drive motor bearings **PRIOR** to checking motor rotation
- Check oil pump alignment (if applicable)
- Check for correct economizer piping (if applicable)
- Check separate source of liquid refrigerant supply (if applicable, liquid injection oil cooling)
- Check water supply for water-cooled oil cooler (if applicable, water cooled oil cooling)
- Check thermosyphon receiver refrigerant level (if applicable, thermosyphon oil cooling)
- Check for **PROPER PIPE SUPPORTS** and correct foundation
- Check to ensure **ALL** piping **INCLUDING RELIEF VALVES** is completed

Electrical Checks

- Confirm that main disconnect to motor starter and micro is open
- Confirm that electrical contractor has seen this sheet, **ALL PERTINENT WIRING** information, and drawings
- Confirm proper power supply to the starter package
- Confirm proper motor protection (breaker sizing)
- Confirm that all wiring used is stranded copper and is 14 AWG or larger (sized properly)
- Confirm all 120 volt control wiring is run in a separate conduit from all high voltage wiring
- Confirm all 120 volt control wiring is run in a separate conduit from oil pump and compressor motor wiring
- Confirm no high voltage wiring enters the micro panel at any point
- Check current transformer for correct sizing and installation
- Check all point-to-point wiring between the micro and motor starter
- Confirm all interconnections between micro, motor starter, and the system are made and are correct
- Ensure all electrical panels are free from installation debris, METAL PARTICLES, and moisture

After the above items have been checked and verified:

- Close the main disconnect from the main power supply to the motor starter
- Close the motor starter disconnect to energize the micro
- Manually energize oil pump and check oil pump motor rotation
- Manually energize compressor drive motor and check motor rotation
- Leave micro energized to ensure oil heaters are on and oil temperature is correct for start-up

Summary: The Frick Field Service Supervisor should arrive to find the above items completed. He should find an uncoupled compressor drive unit (to verify motor rotation and alignment) and energized oil heaters with the oil at the proper standby temperatures. Full compliance with the above items will contribute to a quick, efficient and smooth start-up.

The Start-up Supervisor will:

1. Verify position of all valves
2. Verify all wiring connections
3. Verify compressor motor rotation
4. Verify oil pump motor rotation
5. Verify the % of FLA on the micro display
6. Verify and finalize alignment (if applicable)
7. Calibrate slide valve and slide stop
8. Calibrate temperature and pressure readings
9. Correct any problem in the package
10. Instruct operation personnel

NOTE: Customer connections are to be made per the electrical diagram for the motor starter listed under the installation section and per the wiring diagram listed under the maintenance section of the IOM.

Please complete and sign this form & fax to 717-762-8624 as confirmation of completion.

Frick Sales Order Number: _____
 Compressor Model Number: _____
 Unit Serial Number: _____
 End User Name: _____
 Address of Facility: _____
 City, State, Zip: _____

Print Name: _____
 Company: _____
 Job Site Contact: _____
 Contact Phone Number: _____
 Signed: _____



Start-up Report

Frick Order No: _____

Sold To: _____ Contact Name: _____ Date: _____
End User: _____ Contact Name: _____ Phone: _____
End User Address: _____ Fax No: _____
City, State, Zip: _____ Start-up Representative _____

Unit General Information

Unit Model # _____ Customer Package Identification # _____
Compressor Serial # _____ Separator National Board # _____
Unit Serial # _____ Oil Cooler National Board # _____
Evaporator National Board # _____ Serial # _____ Condenser National Board # _____ Serial # _____
Oil Pot National Board # _____ H.P. Receiver National Board # _____
Economizer National Board # _____ Suction Accumulator National Board # _____
Refrigerant _____ Oil Filters _____ Lube Oil Type _____ Design Operating Conditions
Oil Cooling _____ ° Suct. / _____ ° Disch.

Micro Information

Micro Type _____ Program Software Ver # _____ and Date _____ UL Serial # _____
Digital I/O Board #1 Serial # _____ Software Ver # _____ and Date _____
Digital I/O Board #2 Serial # _____ Software Ver # _____ and Date _____
Analog Board #1 Serial # _____ Software Ver # _____ and Date _____
Analog Board #2 Serial # _____ Software Ver # _____ and Date _____

Compressor Motor Starter / Drive Information

Manufacturer _____ Part # _____ Model # _____
Starter Type _____ Serial # _____
Input Voltage _____ Voltage Range _____ Phase _____ Hz _____ Current _____
Output Voltage _____ Phase _____ Hz _____ Max FLA _____ Max LRA _____ Min Load FLA _____ Job FLA _____
Logic Board Serial # _____ U33 Prog. Ver. _____ Date _____ P/N _____
U34 Prog. Ver. _____ Date _____ P/N _____
U45 Prog. Ver. _____ Date _____ P/N _____
Harmonic Filter Serial # _____ Prog. Ver. _____ Date _____ P/N _____
Frick Interface Serial # _____ Prog. Ver. _____ Date _____ P/N _____
CT Location Checked CT Phase _____ CT Ratio _____ Transition Time _____ DBS Ver.# _____

Oil Pump Information

Pump Mfg. _____ Model # _____ Serial # _____ Motor Mfg. _____ H.P. _____
Motor RPM _____ Service Factor _____ Volt _____ HZ _____ FLA _____ Design _____ Code _____ Starter Size _____

Cooling Fan Information

Motor HP _____ RPM _____ Service Factor _____ Volt _____ Hz _____ FLA _____ Cooling Fans _____

Special Options

_____ _____ _____ _____

Prestart Checks

- | | | |
|---|---|---|
| <input type="checkbox"/> Installation, Foundation | <input type="checkbox"/> Compressor PHD Setup | <input type="checkbox"/> Coolant Installed |
| <input type="checkbox"/> Position of all valves | <input type="checkbox"/> Motor PHD Setup | <input type="checkbox"/> 4-20 Coolant Loop Pump Setup |
| <input type="checkbox"/> Proper oil charge | <input type="checkbox"/> Motor Winding RTD's Setup | <input type="checkbox"/> Coolant Loop Temp Setup |
| <input type="checkbox"/> All wiring connections | <input type="checkbox"/> Motor Bearing RTD's Setup | <input type="checkbox"/> Cooling Fan Motor I/O Setup |
| <input type="checkbox"/> Starter Cleanliness | <input type="checkbox"/> Motor Temperature Thermistor Setup | <input type="checkbox"/> Cooling Fan Rotation Checked |
| <input type="checkbox"/> All micro settings | <input type="checkbox"/> 4-20 Motor Drive Signal Calibrated | <input type="checkbox"/> Oil pump motor rotation |
| <input type="checkbox"/> 4-20 CT Channel 16 Setup | <input type="checkbox"/> Cold alignment | <input type="checkbox"/> Motor rotation |
| <input type="checkbox"/> 4-20 Output Calibration - Liquid Makeup Valve, Coolant Temp Valve, Economizer Makeup Valve | | |

Configuration

Capacity	Channel	Direction	Package
Mode 1 _____	_____	_____	Compressor _____
Mode 2 _____	_____	_____	Pump _____
Mode 3 _____	_____	_____	Dual Pump _____
Mode 4 _____	_____	_____	Drive _____
VFD Hi & Low PI Control	_____	_____	Refrigerant _____ K-Factor _____
Miscellaneous			Filter _____
Sequencing _____			PowerPac _____
Condenser _____			
Screen Saver _____			

Page 2

Unit Serial # _____ Frick Order No: _____

Mode _____ Capacity Control Setpoints				Mode _____			
Setpoint _____		Regulation Safeties		Setpoint _____		Regulation Safeties	
High	Low	Load Inhibit	_____	High	Low	Load Inhibit	_____
Prop. Band	_____	Force Unload	_____	Prop. Band	_____	Force Unload	_____
Dead Band	_____	Warning	_____	Dead Band	_____	Warning	_____
Cycle Time	_____ Sec	Warning Delay	_____ Sec	Cycle Time	_____ Sec	Warning Delay	_____ Sec
VFD Prop Band	_____	Shutdown	_____	VFD Prop Band	_____	Shutdown	_____
VFD Integ. Time	_____ Sec	Shutdown Delay	_____ Sec	VFD Integ. Time	_____ Sec	Shutdown Delay	_____ Sec
Channel	_____			Channel	_____		
Auto Cycle		Low Suction		Auto Cycle		Low Suction	
Start	_____	Load Inhibit	_____	Start	_____	Load Inhibit	_____
Start Delay	_____ Min	Force Unload	_____	Start Delay	_____ Min	Force Unload	_____
Stop	_____	Warning	_____	Stop	_____	Warning	_____
Stop Delay	_____ Min	Warning Delay	_____ Sec	Stop Delay	_____ Min	Warning Delay	_____ Sec
		Shutdown	_____			Shutdown	_____
		Shutdown Delay	_____ Sec			Shutdown Delay	_____ Sec

Compressor Safeties			
High Discharge Temperature		High Suction Pressure	
Load Inhibit	_____	Load Inhibit	_____ PSIG
Force Unload	_____	Force Unload	_____ PSIG
Warning	_____	Warning	_____ PSIG
Warning Delay	_____ Sec	Warning Delay	_____ Sec
Shutdown	_____	Shutdown	_____ PSIG
Shutdown Delay	_____ Sec	Shutdown Delay	_____ Sec
High Discharge Pressure		Dual Mode	_____
Regulation Modes 1 & 3	Modes 2 & 4		
Load Inhibit	_____ PSIG		
Force Unload	_____ PSIG		
Warning	_____ PSIG		
Warning Delay	_____ Sec		
Shutdown	_____ PSIG		
Shutdown Delay	_____ Sec		
Maximum Discharge Pressure	_____ PSIG		
Highest Cap. To Permit Start	_____ %		
Start Period Before Cap. Increase	_____		
Stopping Period For Cap. Unload	_____		
Compressor Auto Mode Min. Cap.	_____ %		
Capacity Unload Assist.	_____ Rate _____ %		
Separator Velocity Ref.	_____		
Compression Ratio	_____		
Liquid Slug Warning	_____		
Liquid Slug Shutdown	_____		
		Economizer	_____
		On When Above	_____ %
		Off When Below	_____ %
		Override Discharge Pressure	_____
		Port Value	_____
		Pressure Input	_____
		Fixed Pressure Setpoint	_____
		Balance Piston	
		On	_____ %
		Off	_____ %
		Ignore Delay	_____ Min
		Fail Delay	_____ Min
		Oil Log	_____ Delay _____ Sec.
		Main Oil Injection On When Discharge Temperature Is Above	_____ °F for _____ Sec

Package Safeties			
Low Compressor Oil Temperature		Pull Down _____	
Warning	_____ Delay _____ Sec	Capacity Position	_____ %
Shutdown	_____ Delay _____ Sec	Amount of Time	_____ Sec
High Compressor Oil Temperature		Pump Down _____	
Warning	_____ Delay _____ Sec	On When Suction Above	_____ PSIG Delay _____ Min
Shutdown	_____ Delay _____ Sec	DX Circuit	
Low Compressor Oil Pressure		#1 Action _____	
Warning	_____ PSI Delay _____ Sec	Off When Below	_____ %
Shutdown	_____ PSI Delay _____ Sec	On When Above	_____ %
High Filter Pressure		#2 Action _____	
Warning	_____ PSI Delay _____ Min	Off When Below	_____ %
Shutdown	_____ PSI Delay _____ Min	On When Above	_____ %
Main Oil Injection		Liquid Injection _____	
Shutdown	_____ PSI Delay _____ Sec	On When Above	_____ Delay _____ Sec
	Oil Heater Off Above _____	Dual Port Transition	_____
	High Level Shutdown Delay _____ Sec		
	Low Oil Level Delay _____ Sec	Hot Gas Bypass _____ %	
	Oil Pump Lube Time Before Starting _____ Sec	Power Assist _____ Sec	
	Dual Pump Transition Time _____ Sec		



Page 3 Unit Serial # _____ Frick Order No: _____

Compressor Motor Setpoints and Information

Motor Name Plate	VFD	Manufacturer _____
Motor Amps _____	Maximum Drive Output ____ %	Frame Size _____
Volts _____	Minimum Drive Output ____ %	H.P. _____
Service Factor _____	Remote Control	RPM _____
Horsepower _____	Rate Of Increase _____ % Delay ____ Sec	Serial # _____
CT Factor _____	Rate Of Decrease _____ % Delay ____ Sec	Service Factor _____
Recycle Delay _____ Min	Capacity Control	Voltage _____
High Motor Amps	When Slide Valve Reaches _____ %	Hz _____
Load Inhibit _____	Drive Speed Reaches _____ %	Design _____
Force Unload _____	Variable Speed Min. Slide Valve Position _____ %	Code _____
Warning _____ Delay ____ Sec	Skip Frequency Bands	Bearing Type _____
Shutdown _____ Delay ____ Sec	Bottom _____	Motor Coupling _____
	Top _____	

Low Motor Amps		
Shut Down _____ Delay ____ Sec		
Confirmed Running Motor Amps _____		
Starting Motor Amps Ignore Period _____ Sec		

Vyper Coolant Setpoints

Vyper Standby Time _____ Vyper Coolant Low Temp. Alarm _____ Delay _____ Shutdown _____ Delay _____
High Temp. Alarm _____ Delay _____ Shutdown _____ Delay _____

PHD Monitoring Setpoints

Compressor Bearing _____

Suction End	Delay	Discharge End	Delay
High Warning _____ gF _____ Sec		High Warning _____ gF _____ Sec	
High Shutdown _____ gF _____ Sec		High Shutdown _____ gF _____ Sec	

Motor Bearing _____

Shaft Side	Delay	Opposite Shaft Side	Delay
High Warning _____ F _____ Sec		High Warning _____ F _____ Sec	
High Shutdown _____ F _____ Sec		High Shutdown _____ F _____ Sec	

Motor Stator _____

Stator 1	Delay	Stator 2	Delay
High Warning _____ F _____ Sec		High Warning _____ F _____ Sec	
High Shutdown _____ F _____ Sec		High Shutdown _____ F _____ Sec	

Stator 3 **Delay**
High Warning _____ F _____ Sec
High Shutdown _____ F _____ Sec

Condenser Control

Condenser Control Setpoint _____

Digital Controls	Step Order
Module A	_____
Module B	_____
Module C	_____
Module D	_____

Step Up Dead Band _____ PSI
Step Up Delay _____ Sec
Step Down Dead Band _____ PSI
Step Down Delay _____ Sec
High Pressure Override _____ PSI
High Pressure Override Delay _____ Sec

Analog Controls Analog Output A _____
Analog Output B _____
Proportional Band _____ PSI
Integration Time _____ Sec
High Limit _____ PSI
Low Limit _____ Sec

Miscellaneous

Remote Capacity Deadband _____ %
High Compressor Oil Pressure _____
Shutdown _____ PSI Delay ____ Sec
Max Slide Valve Timer _____ 1/10 Sec
Max Discharge Pressure _____ PSI
Max Discharge and Oil Temp _____ °F

Page 4

Unit Serial # _____ Frick Order No: _____

P&ID Setpoints

Name	_____	_____	_____	_____
Control	_____	_____	_____	_____
Action	_____	_____	_____	_____
Control Point	_____	_____	_____	_____
Device Source	_____	_____	_____	_____
Device Channel	_____	_____	_____	_____
Setpoint	_____	_____	_____	_____
Dead Band	_____	_____	_____	_____
Prop. Band	_____	_____	_____	_____
Integral Gain	_____	_____	_____	_____

Communications

Compressor ID _____

Comm 1	Comm 2	Comm 3	
Baud Rate _____	Baud Rate _____	Baud Rate _____	
Data Bits _____	Data Bits _____	Data Bits _____	
Stop Bits _____	Stop Bits _____	Stop Bits _____	
Parity _____	Parity _____	Parity _____	
RS 485 Connection _____	RS 485 Connection _____	RS 485 Connection _____	
Protocol _____	Protocol _____	Protocol _____	Use Map File _____

Ethernet

IP Data	Naming Data	Protocols
Address Type _____	Host Name _____	ModBus TCP _____
IP Address _____	Work Group _____	Ethernet I/P _____
Gateway Address _____	Comments _____	Profinet _____
Subnet Mask _____		
Web Server Port _____		

Compressor Operating Log Sheet				Starter Operating Log Sheet			
Date				Average Current			
Time				Current Phase A			
Hour Meter Reading				Current Phase B			
Equip. Room Temp.				Current Phase C			
Suction Pressure				Full Load Amps			
Suction Temperature				Output Frequency			
Suction Superheat				Output Voltage			
Discharge Pressure				DC Bus Voltage			
Discharge Temperature				Input Power kW			
Corresponding Temperature				Actual Speed			
Oil Pressure				Speed Command			
Oil Temperature				Ambient Temp F.			
Oil Filter Pressure Drop				Convert Heatsink Temp. F.			
Separator Temperature				Baseplate Temp. F.			
Slide Valve Position				VSD Operating Mode			
Volume Ratio (VI)				Harmonic Filter Present			
Motor Amps / FLA %				Harmonic Filter Mode			
Capacity Control Setpoint				Water Pump Energized			
Oil Level				Precharge Relay Energized			
Oil Added				Trigger SCR's Energized			
Seal Leakage (Drops/Min.)				DC Inverter Link Current			
Evaporator. EWT F.				Motor Winding Temp. F.			
Evaporator LWT F.				Humidistat % RH			
Condenser EWT F.				Vyper Coolant Temp. F.			
Condenser LWT F.				Total kWh			

VIBRATION DATA SHEET

Date: _____
End User: _____
Address: _____

Sales Order Number: _____
Installing Contractor: _____
Service Technician: _____

Equipment ID (As in Microlog): _____
Compressor Serial Number: _____
Unit Serial Number: _____
National Board Number: _____
Running Hours: _____
Manufacturer and Size of Coupling: _____
Motor Manufacturer: RAM _____
Motor Serial Number: _____
RPM: _____ Frame Size: _____ H.P. _____
Refrigerant: _____
Ambient Room Temperature: _____ °F
Operating Conditions:

SUCTION		DISCHARGE		OIL		SEPARATOR		Slide Valve Position	%
Press	#	Press	#	Press	#	Temp	°F	V.I. Ratio	
Temp	°F	Temp	°F	Temp	°F			F.L.A.	%

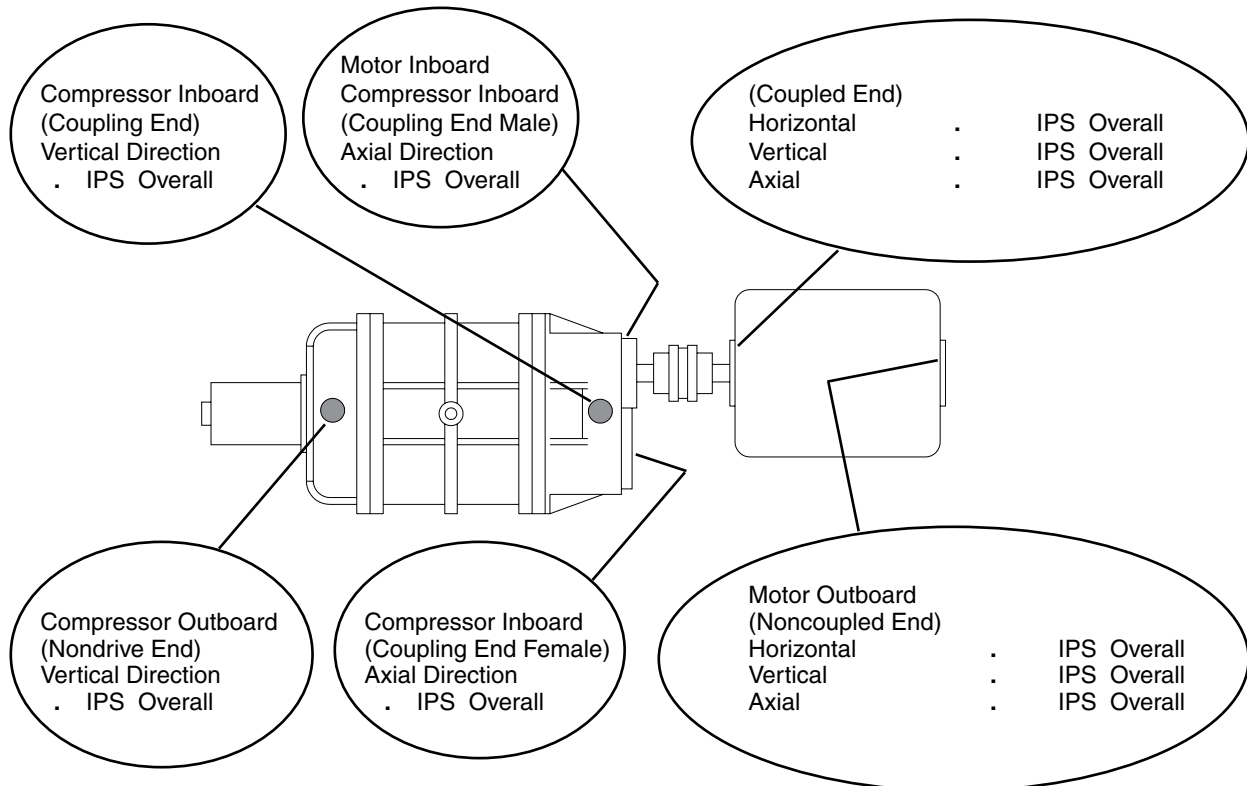

Index

Symbols

3-phase bus, 10
3-phase ground, 51
3-phase power, 10
3-phase supply, 51

A

across-the-line starters, 11
adjusting valve, 17
alarm descriptions, 14
angular contact ball bearings, 13
autocycle, 19
auxiliary oil reservoirs, 6

B

back-feeding, 19
Balance pistons, 13
Bare Compressor Replacement, 39
battery backup, 12
bleed valve, 22
booster applications, 7,10,14
BPU Coupling, 5

C

cable trays, 51
Capacity Linear Transmitter, 32
charging valve, 6
Check valve, 19
circuit breaker, 6
circuit breaker disconnect, 10,11
closed-loop fluids, 8
closed-loop system, 8
coalescer filter, 6
coalescer filter element, 23
coalescer filter elements, 14
codes, 51
cold-start valve, 14
 bonnet, 30
 safety mask, 30
 spring, 30
 valve body, 30
 valve seat gasket, 30
Comm Port Protection, 53
Communications, 53
compressor foundation, 4
 compressor vibration, 4
 I-beams, 4
 noise curtains, 4
 sound attenuation, 4
 spring isolators, 4
 vibration isolators, 4
compressor hydraulic system, 15
compressor lubrication, 14
compressor motor starter, 24
Compressor Operating Log Sheet, 59
Compressor Rotation, 5
compressor suction, 15
compressor unloader cylinder, 32
condenser, 30
condenser inlet, 6
condenser pressure, 6
condensing pressure, 6
Conduit, 51
constant speed starters, 51
constant voltage transformer, 10
control power regulator, 12
control power transformer, 11
cooling water, 8
CoolWare™, 20
Coupling Data Table, 5

coupling hubs, 5
CT burden ratings, 11
Current Transformer, 11

D

Daisy-chaining, 53
"D" Flange adapter, 13
Demand Pump
 ball bearing, 25
 bearings, 25
 bearing housing, 24
 bearing retainer washer, 24
 bearing spacer, 25
 carbon graphite bushings, 26
 End Clearance Adjustment, 27
 idler, 25
 idler bushing, 24
 idler pin, 24
 inner ball bearing, 25
 inner snap ring, 24
 locknut, 24
 Lubrication, 27
 mechanical seal, 24
 outer snap ring, 24
 Packing Adjustment, 27
 pump end clearance, 26
 Pump head, 25
 pump head, 24
 rotor hub, 25
 rotor shaft, 26
 sealing faces, 25
 seal housing bore, 25
 seal seat, 25
 seal spring, 25
 shaft snap ring, 25
 single-row ball bearing, 24
 Standard Mechanical Seal, 25
 thrust-bearing assembly, 24,26
 Troubleshooting The Demand Pump
 Air leak, 27
 Cavitation, 27
 cavitation, 26
 Discharge Port, 27
 end clearance, 27
 Gate valve, 27
 Head position, 27
 liquid system, 27
 Liquid vaporizing, 26,27
 misalignment, 26,27
 Pressure Gauge, 27
 pressure gauge, 26
 Pump Liquid Chamber, 26
 Relief valve, 27
 sheave, 27
 Starving, 27
 Strainer, 27
 Suction line, 26
 suction port, 26
 vacuum gauge, 26
differential pressure, 14
differential pressure control valve, 16
digital voltmeter, 31
DIN connector, 33
discharge check valve, 14,19
discharge pressure, 13,15,31
discharge pressure transducer, 31
discharge temperature, 20
disconnect switches, 22,23
disc packs, 5
double acting solenoid valve, 16
drain valve, 22,23
dry nitrogen, 5
dual dip tube method, 7

E

economizer
 back-pressure regulator valve, 9,10
 check valve, 9
 disc-type check valves, 9
 dual-setpoint feature, 10
 DX economizer, 9
 DX vessel, 10
 economizer output, 10
 electric shutoff option, 10
 flashing liquid, 9
 flash gas, 10
 gas flow, 9
 isolation valve, 9
 liquid feed solenoid, 9,10
 outlet pressure regulator, 9
 Packaged Refrigerant Recirculation, 9
 partial load, 9
 piston-type check valves, 9
 shell and coil economizer, 9
 strainer, 9
 subcooled liquid, 9
 subcooling liquid, 9
 suction bypass, 9
 suction check valve bypass, 10
 suction check valve bypass line, 9
electrical enclosure, 10
entrapped refrigerant, 23
equalizing pressure, 29
evaporator, 8,30
expansion valve, 7
expansion valve bulb, 7
external oil cooler, 5
External Oil Cooling, 20
EZ-COOL™ Liquid Injection
 analog board one, 17
 D/A converter chip, 17
 Dead Band, 18
 discharge temperature, 18
 driver chip, 17
 High Oil Temperature alarm, 17
 HMRR valve, 17
 Integral Gain, 18
 Proportional gain, 18
 proportional gain setpoint, 19
 Quantum Panel PID loop, 17

F

filter elements, 6
flash memory, 12
flexible coupling, 32
float level, 8
Foundation, 4,13
Freeze-up protection, 19
Frick refrigeration oil, 28

G

gasket, 22
gas bypassing, 13
gauges, 5
gauge pressures, 28
Grease Compatibility, 29
Grease Compatibility Chart, 29

H

Halocarbon, 17
hand expansion valve, 20
heat exchanger, 8
high-stage compressor, 16
High capacity roller bearings, 13
high discharge pressure, 30
high oil temperature, 29

high oil temperatures, 29
High pressure gas, 7
high pressure gas, 7
high stage applications, 14
high suction pressure, 30
High suction superheat, 30
high suction superheat, 30
Holding-charge, 5
Hot oil, 6
hydraulic cylinder, 15

I

inlet service valve, 22
insulating, 19
interposing relay, 11

K

keyway setscrews, 5

L

leak test, 22
level-control method, 8
liquid feed solenoid, 16
liquid injection, 16
Liquid Injection Oil Cooling, 20
liquid injection strainer, 23
liquid injection system, 7
liquid injection thermostatic valve, 23
liquid injection valve, 7
Liquid refrigerant, 6
liquid supply service valve, 23
low receiver level, 30

M

magnetic field, 51
Maintenance
condensed refrigerant, 30
disconnect switches, 21
dry nitrogen, 21
liquid injection valves, 21
oil filters, 21
oil heater circuit breaker, 21
premature bearing failure, 21
Proper Installation of Electronic Equipment, 49
Servicing the Cold-Start Valve
bonnet, 30
Bonnet Cap Screw Torque Values, 31
valve body, 30
valve housing, 30
slugging, 21
stop valve, 30
suction accumulators, 21
suction strainer, 21
Vibration Data Sheet, 60
vibration level, 21
maintenance, 21
main oil filter, 22
manual solenoid, 23
Manway Bolts, 20
manway cover, 23
metering valve, 16
microprocessor control system, 11
micro enclosure, 6
Mixing of oils, 5
mixing valve, 7
motor alignment, 5
motor bearings, 20,29
Motor cycling, 10
Motor Replacement, 39
motor starter packages, 10
movable slide stop, 15
movable slide valve, 15

Moveable slide valve, 13
MSS solenoid valve, 15

N

needle valve, 15
nitrogen charge, 5
normal charging level, 6
nuisance oil level cutouts, 22

O

Oil-entrained refrigerant, 22
oil-side piping, 7
oil coolers, 16
Oil distillers, 6
oil filter, 6
oil filter cartridges, 23
oil heaters, 6
Oil heat of rejection, 6
Oil Level Transmitter, 33
oil pump, 14,23
Oil Pump Coupling, 5
oil pump starter, 11
Oil quality, 28
oil seal, 13
oil strainer elements, 23
Oil temperature, 6
oil temperature alarm, 17
oil temperature control, 6
Operating Log, 30
Operating Log Sheet, 54
Optical Isolation, 53
outlet service valve, 22

P

plate and shell oil cooler, 6,8
potentiometer, 32
power feed, 51
power fluctuations, 11
pressure regulating valve, 17
pump-out connection, 19
pump head, 24
purge valve, 22
P & I Diagram, 40
PVC conduit, 51

Q

Quantum™LX, 53

R

reboot, 53
refrigerant isolation valves, 7
refrigerant vapor, 13,22
regulating control transformer, 11
rigging, 4
rotors, 13

S

SBC, 31
SBC Board, 10
scaling rates, 8
ScrewSelect™, 20
self-lubricating, 13
separator, 5
service valve, 23
service valves, 24
setpoint, 12
SGC compressor, 15
shunting device, 11
shutdown cycles, 6
sight glass, 6,14,23
slide stop, 13
slide valve, 13,32
Slide Valve Position potentiometer, 32

Sola®, 10
solenoid, 23
solenoid valve, 7,8
solenoid valves, 15
Star Networks, 53
Starter Operating Log Sheet, 59
start-up, 14
start-up, 20
starter package, 10
Starter Wiring Diagram, 10
stop valve, 23
strainer, 8,23
strainer basket, 23
strainer elements, 23
strainer inlet service valve, 22
suction check valve, 19
suction check valve bypass, 14
suction service valve, 23
suction superheat, 29
suction valve, 23
superheating suction gas, 13
Surge suppression, 53
system suction pressure, 14,19

T

temperature-regulating valve, 38
Adjustment, 38
direct acting valve, 38
reverse acting valve, 38
Sensing Bulb, 38
Stroke Adjustment, 38
valve plate, 38
temperature control valve, 16
temperature sensor, 16
Temperature Transmitter, 33
Thermal Expansion Valve, 17,20
thermal expansion valve, 29,37
thermosiphon oil cooler, 7
Thermosiphon oil cooling, 6,16
thermowell, 7
threaded metallic, 51
threaded PVC-coated metallic, 51
three-way oil temperature valve, 8
throttling valve, 14
timer relay, 10
torque analysis, 10
transducer, 31
transmitter unit, 33
Troubleshooting
Excessive Noise and Vibration, 34
Gradual Oil Loss, 34
High Oil Temperature, 35
Low Oil Temperature, 35
Noise and Vibration, 36
Oil Pressure Fluctuates, 36
Oil Pressure Rapidly Drops, 36
Oil Temperature Fluctuates, 35
Rapid Oil Loss, 34
Shaft Seal Leakage, 34
Slide Stop, 35
Slide Stop will not move, 34
Slide Valve, 35
Slide Valve will not move, 34
tunnel, 5
two-pass oil coolers, 6
U
uninterrupted power supply, 53
unshielded, 51
UPS, 53
UPS power system, 10

V

variable frequency drives, 51
variable setpoints, 20
VFD Applications, 50
VFD output, 50
vibration analysis, 20,28
Vibration Data Sheet, 60
voltage, 31
voltage isolation, 53
volume ratio, 15
volume ratio control, 13
volume ratio Vi, 15
VOLUMIZER®, 13
VOLUMIZER® Transmitter, 33

W

water-cooled oil cooler, 8,30
Water cooled oil cooling, 16
water regulating valve, 8
Wiring Harness, 44
wiring harness, 32
wye-delta applications, 11

Q-NET™ network technology...

Connect Your PC
with QUANTUM™LX!

*Take full advantage of Q-NET™
technology with all Frick products!*



System integration is what we do...

- Q-NET™... supports open-protocols for SCADA systems (i.e. Allen-Bradley® DF1, Modbus RTU, Modbus ASCII, and Industrial Ethernet Protocols)
- Q-NET™... connects instantly for local or remote access; no software required
- Q-NET™... can be applied to both new and existing systems
- Q-NET™ means precise control 24 hours a day, seven days a week
- Q-NET™ distributed architecture mean faster, easier, economical installations
- Q-NET™ delivers increased operating efficiency and lowers energy costs

Available on Frick screw compressors, condensers, evaporators, AcuAir® hygienic air handlers, and refrigerant vessels.