

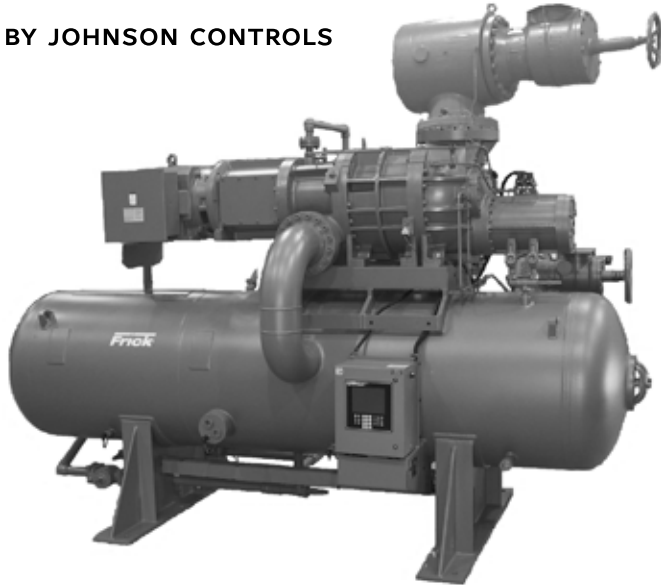

BY JOHNSON CONTROLS



E70-610B SPC (MAY 2007)

SERVICE PARTS LIST

File: EQUIPMENT MANUAL - Section 70
Replaces: E70-610B SPC (SEP 2004)
Dist: 1, 1a, 1b, 1c, 4, 4b, 4c

RWF II

ROTARY SCREW COMPRESSOR UNITS

Models: 496 - 1080

FEATURES AND BENEFITS

RWF II Rotary Screw Compressor Units are engineered and manufactured to meet the exacting requirements of the Industrial Refrigeration Market. All components have been designed and arranged to assure reliability, accessibility, and servicing convenience. Standard units are designed for use as boosters or high-stage machines on ammonia or halocarbon refrigerants and are shipped completely assembled.

COMPRESSOR: The Frick manufactured **RWF II** compressor has been designed utilizing the latest technology to offer the most reliable and energy efficient unit currently available. Setup is easy thanks to the new D-flange connection on our low noise motor that is standard for the **RWF II**. All screw compressor casings are designed and tested in accordance with the requirements of ASHRAE 15 safety code. Rotors are manufactured from forged steel, and use the latest asymmetric profiles. The compressor incorporates a complete antifriction bearing design for reduced power consumption and the bearings selected provide an L10 life in excess of 100,000 hours at design conditions.

CAPACITY CONTROL: Capacity control is achieved by use of a slide valve which provides fully modulating capacity control from 100% to approximately 12% of full load.

“VOLUMIZER®” VARIABLE VOLUME RATIO CONTROL: The **RWF II** compressor includes a patented method of varying the internal volume ratio to match the system pressure ratio, eliminating the power penalty associated with over- or undercompression.

LUBRICATION SYSTEM: The **RWF II** compressor is designed specifically for operation without an oil pump. All oil required for main oil injection and lubrication is provided by positive gas differential pressure. All oil passes through the Frick SuperFilter™ II, specifically designed for increased particle capture and cleaner oil and compressor operation. SuperFilter™ II captures 99% of particles 5 microns and larger and has twice the dirt holding capacity of the original filter for maximum bearing life. It is also designed for horizontal filter mounting and furnished with isolation stop valves and drain connections for ease of servicing. Booster and some low-pressure differential, high-stage applications will require the demand oil pump option.

OIL SEPARATOR/RESERVOIR: The oil separator is a horizontal, three-stage design with integral sump. The separator is designed and constructed in accordance with ASME Section VIII, Div. 1 for a maximum design working pressure of 300 psig. Replaceable Demistifier™ coalescent separator elements are provided for final gas/oil separation of particles down to less than 1 micron.

OIL COOLING: Cooling the compressor oil may be achieved by either EZ-Cool™ liquid-refrigerant-injection oil cooling, water-cooled oil cooling, or thermosyphon oil cooling. Water-cooled and thermosyphon oil-cooled systems are supplied with ASME plate and shell type heat exchangers mounted on the unit. They are also equipped with an oil temperature control valve.

QUANTUM™ LX CONTROL CENTER: The Quantum™ LX control panel is factory mounted, NEMA 4, UL ® listed, and completely wired with all the required safety and operating devices. A 10.4" Active Color VGA Graphics Display offers a high contrast, crisp, clear display of compressor information and status. Additional I/O can be easily installed in the field. This feature provides flexibility for future engine room upgrades and changes. Three field-selectable serial communication ports allow you to choose from a combination of RS-422, RS-485, or RS-232 port configurations for both interpanel and external communications. Ethernet communications are also available for direct connection to the internet. Included in the microprocessor is time-proportioning capacity control, first-out annunciation, prealarms, Volumizer® control, access code protection, lead-lag sequencing, four user-defined capacity control modes, trending, maintenance schedule, and more. The operating conditions at the time of the compressor's last 50 alarms or shutdowns are stored in memory, providing the ultimate in service and troubleshooting convenience.

VALVES: The unit has a combination suction shut-off and check valve with strainer multivalve assembly. The unit's discharge has a mounted combination check and shut-off valve.

OPTIONAL FEATURES: Demand Oil Pump, Dual Oil Filters, Economizer, Oil Temperature Control Valve, Starter Packages, Unit-Mounted Solid-State Starter Packages, Power-Regulating Control Transformer, oversized Suction Valve.

Please check www.frickcold.com for the latest version of this publication.

STANDARD DESIGN DATA (with Metric equivalents) - NOMINAL @ 3550 RPM

| MODEL NO. | COMPRESSOR DISPLACEMENT | | RATINGS R-717 ⁽¹⁾⁽²⁾ | | | | RATINGS R-22 ⁽¹⁾⁽²⁾ | | | | UNIT WEIGHT ⁽³⁾ | |
|-----------|-------------------------|--------|---------------------------------|-------|-------|-------|--------------------------------|-------|-------|-------|----------------------------|--------|
| | | | CAPACITY | | POWER | | CAPACITY | | POWER | | | |
| | CFM | M3/hr | TR | kw | BHP | kw | TR | kw | BHP | kw | lb | kg |
| 496B | 2,920 | 4,961 | 295 | 1,037 | 286 | 213 | 359 | 1,263 | 364 | 271 | 20,500 | 9,299 |
| 496H | 2,920 | 4,961 | 1,054 | 3,706 | 1,182 | 881 | 946 | 3,328 | 1,178 | 878 | NA | NA |
| 676B | 3,982 | 6,765 | 402 | 1,414 | 391 | 292 | 490 | 1,723 | 496 | 370 | 20,800 | 9,435 |
| 676H | 3,982 | 6,765 | 1,422 | 5,002 | 1,612 | 1,202 | 1,206 | 4,241 | 1,615 | 1,204 | NA | NA |
| 856B | 5,068 | 8,610 | 512 | 1,801 | 497 | 371 | 624 | 2,194 | 631 | 471 | 22,500 | 10,206 |
| 856H | 5,068 | 8,610 | 1,807 | 6,354 | 2,056 | 1,533 | 1,511 | 5,315 | 2,165 | 1,615 | NA | NA |
| 1080B | 6,394 | 10,862 | 645 | 2,268 | 629 | 469 | 787 | 2,769 | 902 | 673 | 23,100 | 10,478 |

- Booster conditions are based on -40°F (-40°C) suction and 10°F (-12.2°C) intermediate temperature with liquid at interstage saturation and no superheat.
 - High stage conditions are based on 20°F (-6.7°C) suction and 95°F (35°C) condensing with 10°F (5.5°C) liquid subcooling and 10°F (5.5°C) superheat.
 - Unit weight does not include motor.
- NOTE:** All packages with motors larger than 1250 hp will require a vertical oil separator

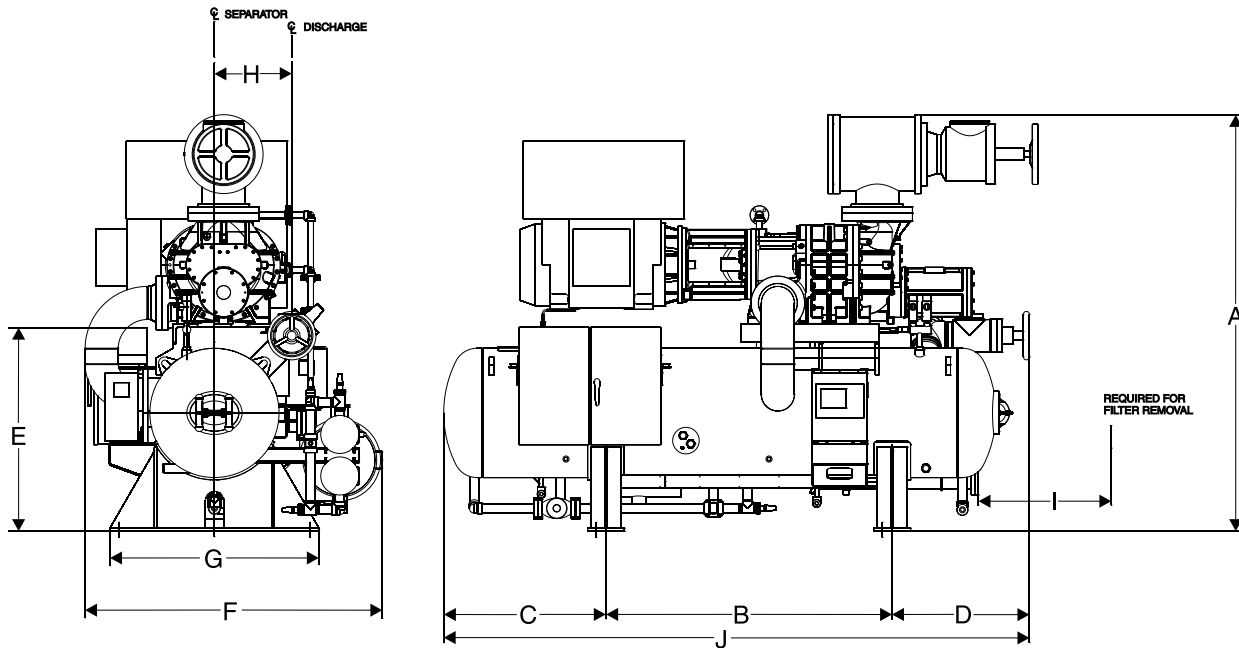

| MODEL NO. | APPROXIMATE DIMENSIONS Inches/Millimeters | | | | | | | | | |
|-----------|---|---------|---------|---------|---------|----------|---------|--------|--------|----------|
| | A | B | C | D | E | F | G | H | I | J |
| 496 | 135/3429 | 93/2362 | 53/1346 | 45/1143 | 60/1524 | 102/2591 | 68/1727 | 25/635 | 39/991 | 191/4851 |
| 676 | 145/3683 | 96/2438 | 51/1295 | 49/1245 | 70/1778 | 108/2743 | 77/1956 | 26/660 | 39/991 | 196/4978 |
| 856 | 151/3835 | 96/2438 | 62/1575 | 50/1270 | 70/1778 | 111/2819 | 82/2083 | 28/711 | 39/991 | 208/5283 |
| 1080 | 151/3835 | 96/2438 | 62/1575 | 50/1270 | 70/1778 | 111/2819 | 82/2083 | 28/711 | 39/991 | 208/5283 |

NOTE: Graphic above for reference only. Other unit sizes vary slightly. Use only certified drawings for erection.

| MODEL NO. | STANDARD CONNECTIONS in./mm | | | |
|-----------|-----------------------------|-----------|----------|-----------|
| | R-717 | | R-22 | |
| | SUCTION | DISCHARGE | SUCTION | DISCHARGE |
| 496 | 12/304.8 | 8/203.2 | 12/304.8 | 8/203.2 |
| 676 | 12/304.8 | 8/203.2 | 12/304.8 | 8/203.2 |
| 856 | 14/355.6 | 8/203.2 | 14/355.6 | 8/203.2 |
| 1080 | 14/355.6 | 8/203.2 | 14/355.6 | 8/203.2 |