

REVISION HISTORY						
ZONE	REV	ECN	DESCRIPTION	DATE	DR	CHK
.	.	6404	INITIAL RELEASE	12/1/95	TWY	RB
.	A	6913	UPDATED TO NEW DWG. FORMAT & STANDARDS	3/10/97	DET	LJO
.	B	7777	UPDATED TO NEW DWG. FORMAT & STANDARDS	6/28/99	MAR	DET
.	C	8064	UPDATED TO NEW DWG. FORMAT	2/21/00	LA	REL
.	D	8267	REPLACE "FRICK" WITH "YORK" (6-PLACES) (Y WAS (E); (A) WAS (A))	10/6/00	DAH	REL
.	E	8706	GENERAL UPDATE OF SYMBOLS	11/7/06	HWK	BJS

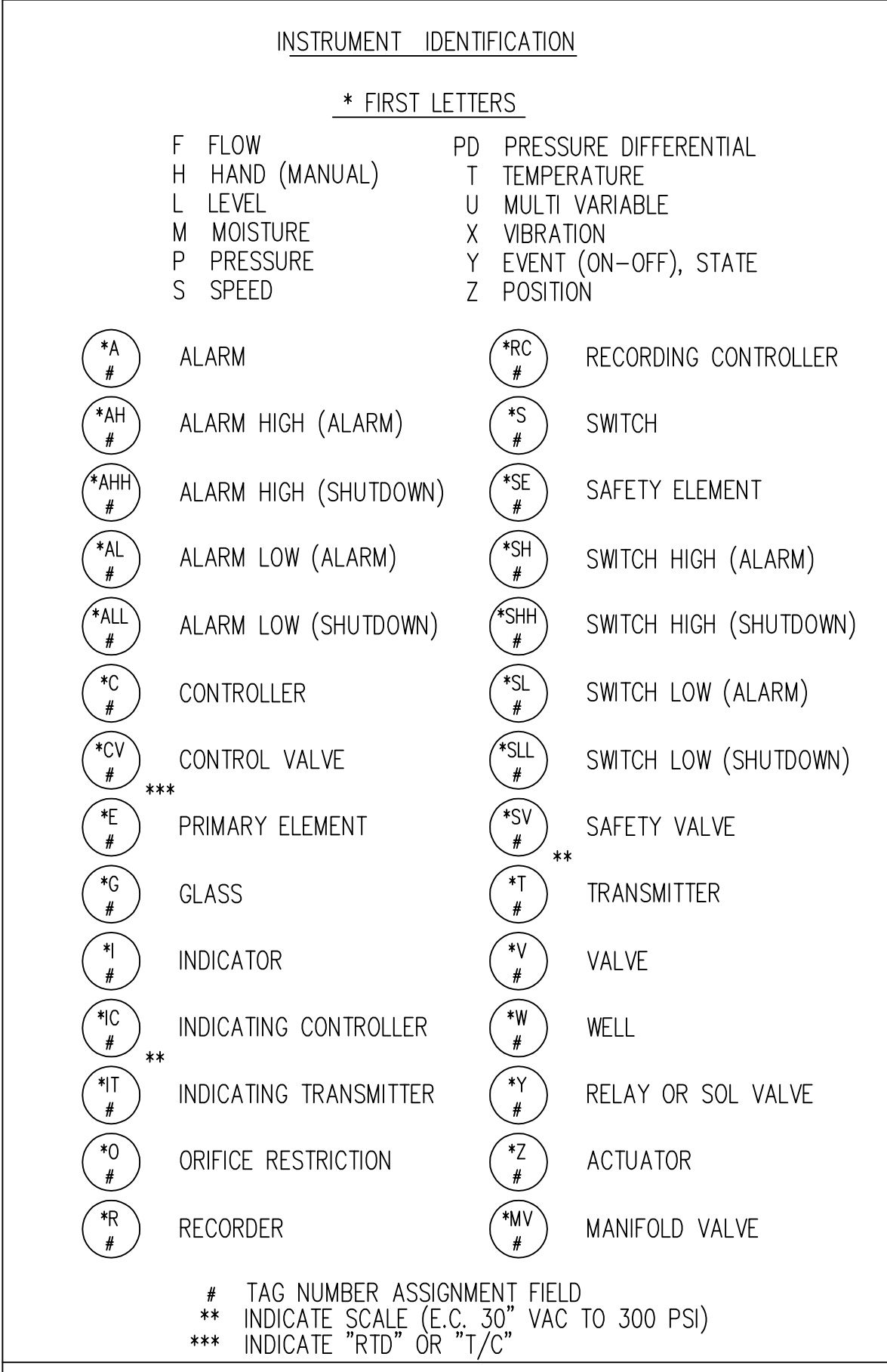

GENERAL INSTRUMENT & TAG NUMBER ASSIGNMENTS

MISC SYSTEM	1 - 99
SYSTEM REFRIGERANT	100 - 299
PURGE UNIT	300 - 349
TRANSFER UNIT	350 - 399
COMPRESSOR	400 - 499
GEAR/MOTOR/TURBINE	500 - 599
WATER, BRINE OR PROCESS	600 - 699
MISC	700 - 999

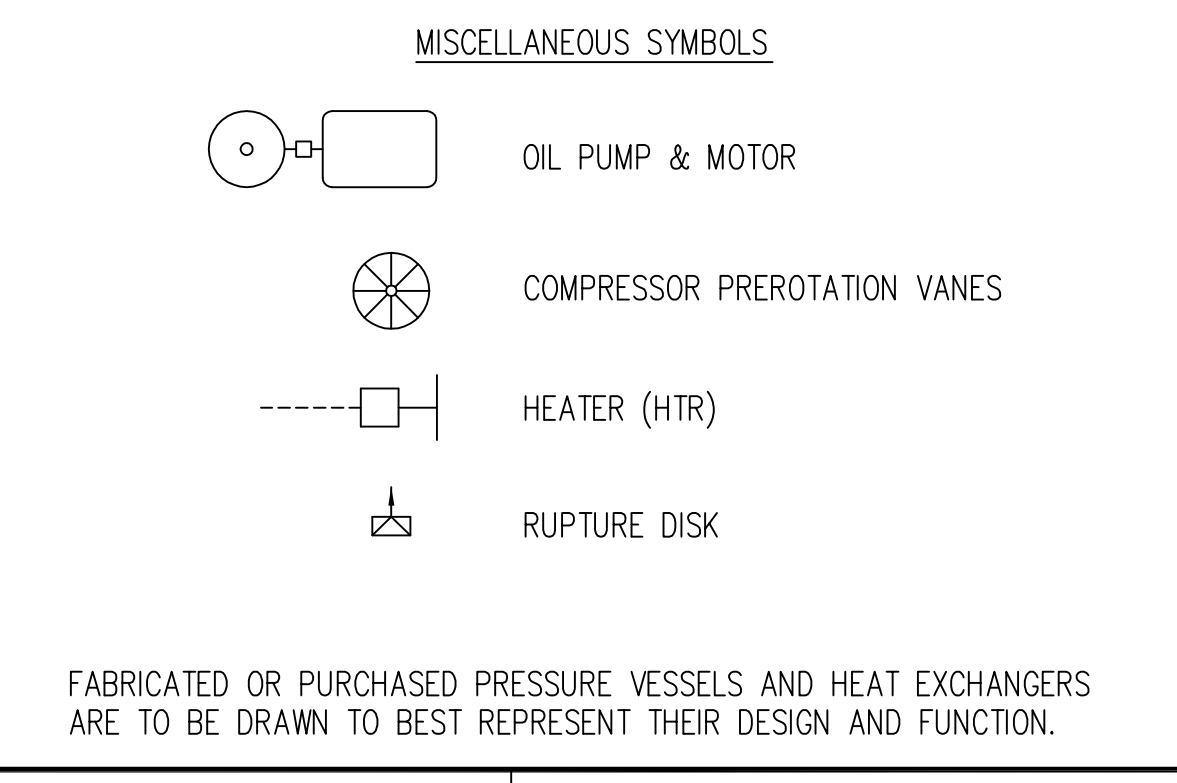
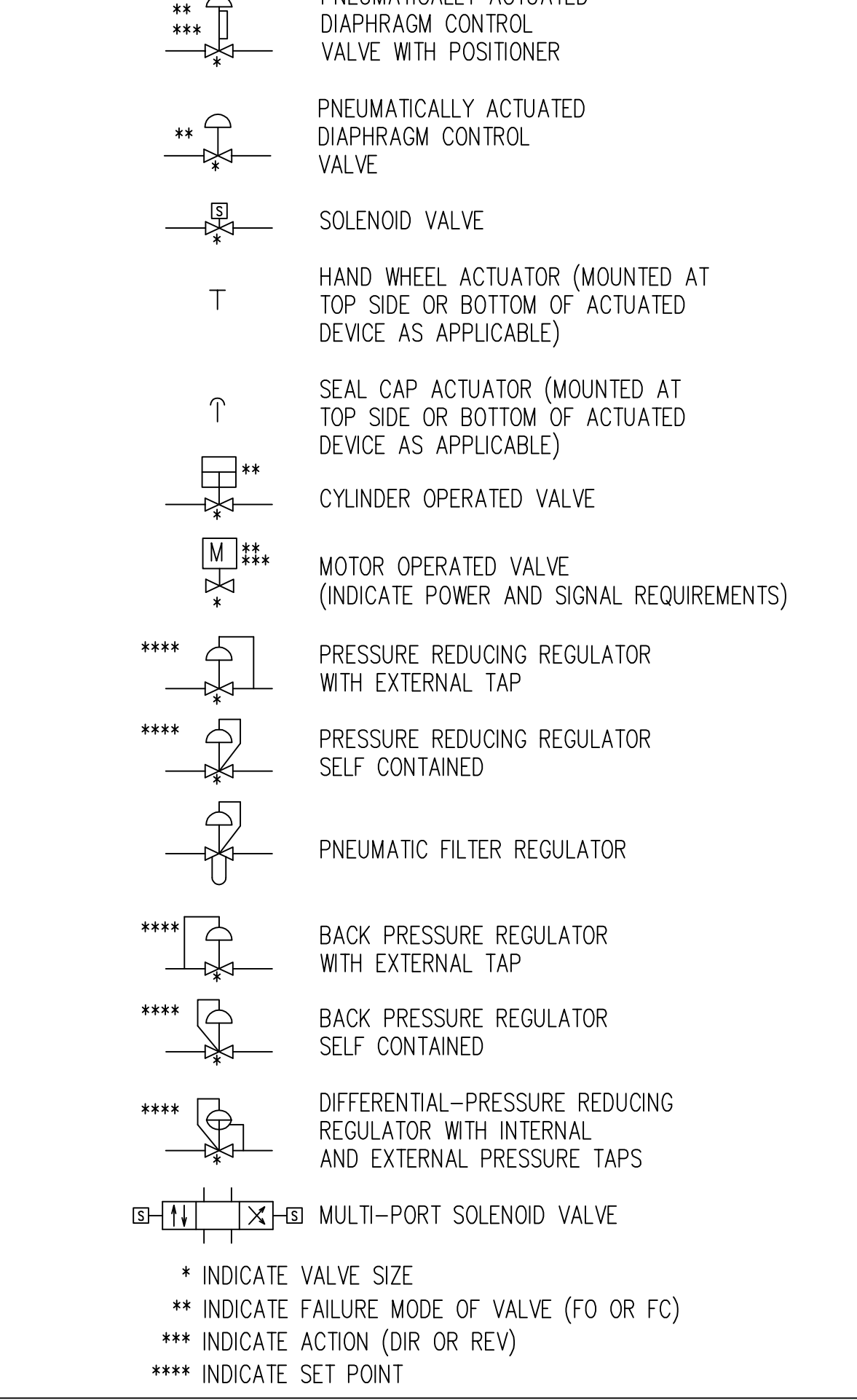
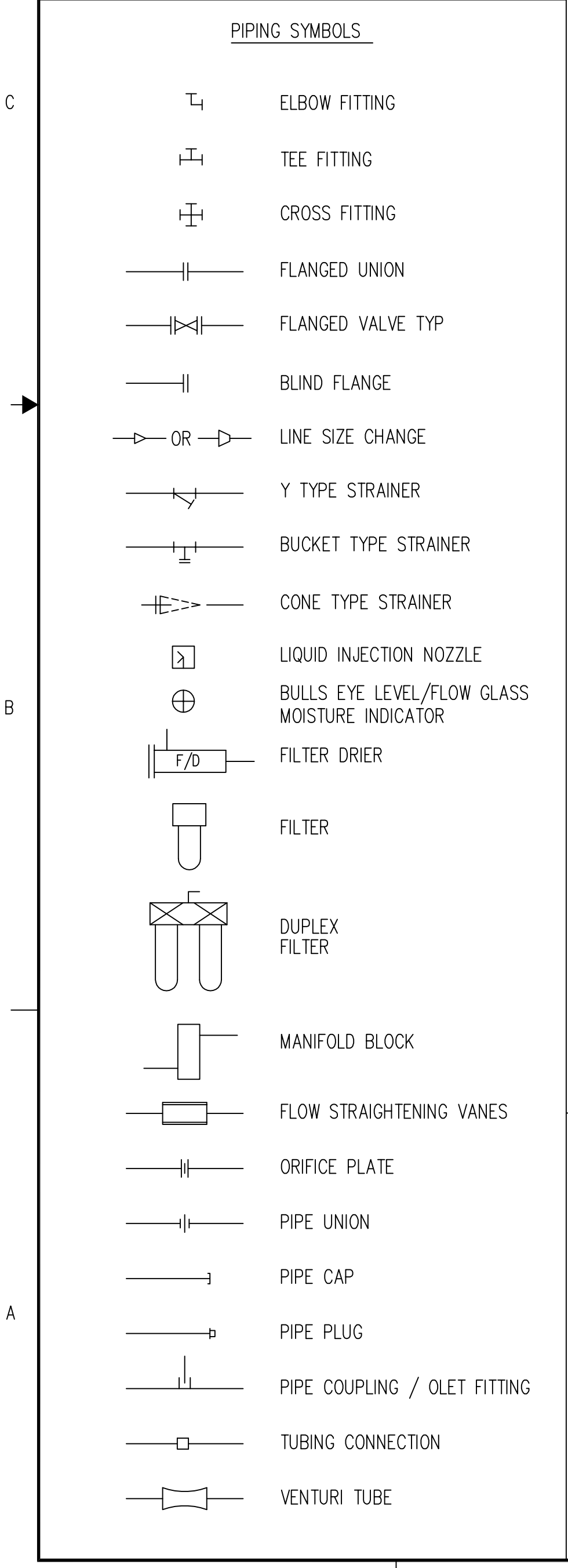
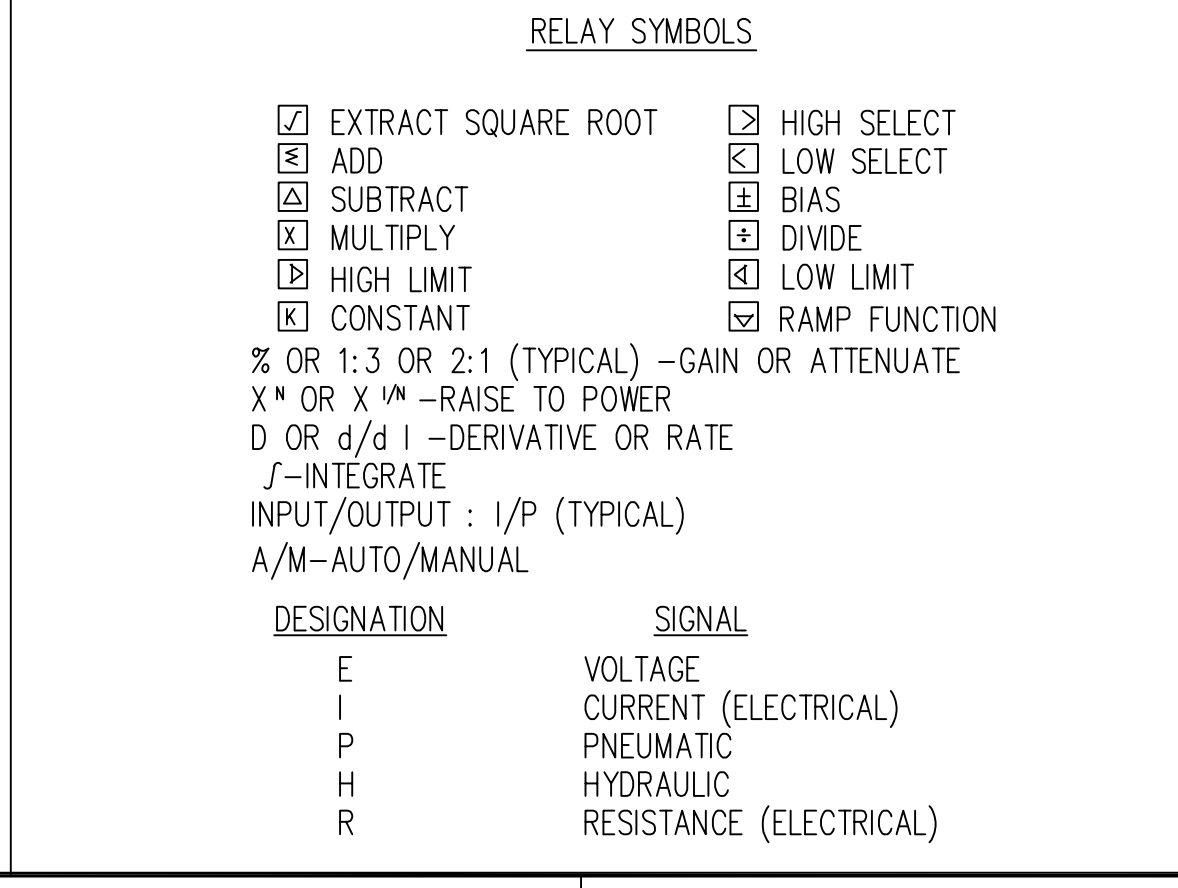
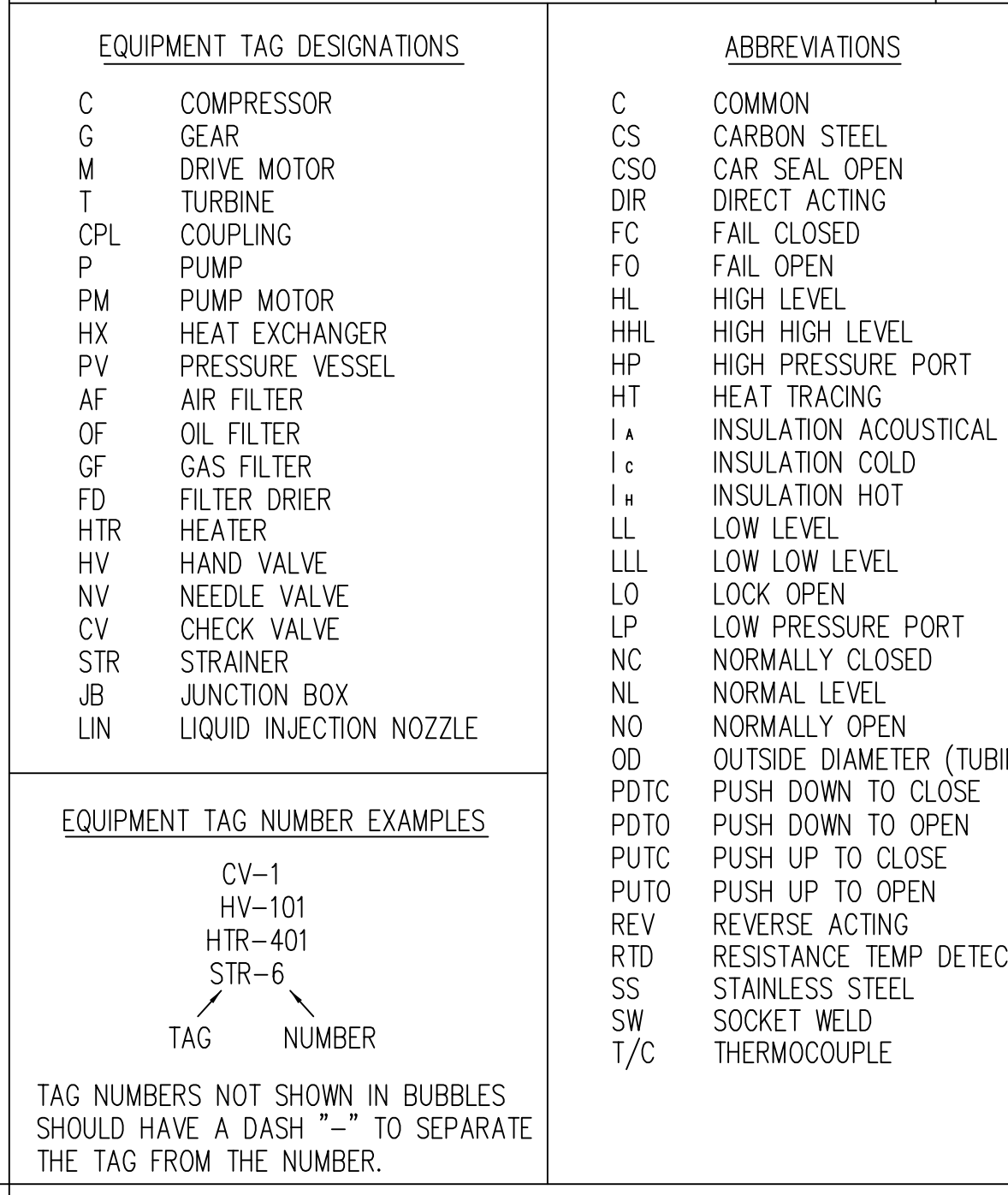

NOTES:
 1. SYMBOL SIZES SHOULD BE AS SHOWN ON A "FULL" SIZE COPY OF THIS P & I DIAGRAM LEGEND DRAWING.
 2. SYMBOL CONVENTION WAS TAKEN FROM ANSI/ISA STANDARDS WHERE AVAILABLE.
 3. FOR ADDITIONAL INSTRUMENT SYMBOLS AND CONVENTIONS REFERENCE ANSI/ISA-S5.1-1984.

UNLESS OTHERWISE SPECIFIED DIMENSIONS ARE IN INCHES DO NOT SCALE		UNLESS OTHERWISE SPECIFIED TOLERANCES PER QWP-18	
DEC 2PL ±	DEC 3PL ±	FRACT ±	ANGLE ±
DR TODD YODER	11/30/95	SIZE	CAGE CODE
CHK THOMAS P. COYLE	11/30/95	DWG NO	REV
APPD R. BRAGER	11/30/95	D 23587	650D0020
CODE	SCALE	SHEET 1	OF 1

YORK Process Systems
 Waynesboro, PA 17268

TITLE
P & I DIAGRAM STANDARD LEGEND