



BY JOHNSON CONTROLS

070-200 SPL (MAY 2002)

**SERVICE PARTS LIST**

File: SERVICE MANUAL - Section 70  
Replaces: S70-200/SPL MAY 2001  
Dist: 3, 3a, 3b, 3c  
Revised: October 16, 2007 Page 3, 20 & 74  
June 8, 2009 Page 33 & 37

**Service Parts List**

***RWB II***

**ROTARY SCREW COMPRESSOR UNITS**

**WITH**

**QUANTUM™ CONTROL**

**MODELS: RWB II 60 through 856**

### HOW TO USE SERVICE PARTS LIST

This Service Parts List is for standard Frick RWB II Plus, Rotary Screw Compressor Units, Models 60—856. Units built with special options, modifications, or conversions are not considered. This Service Parts List provides identification for detail parts by Figure and Index Number, Item Number and Description. To determine replacement part, locate item on Figure 1, 2, etc., note index number, refer to corresponding index number in parts list for item number and description. Quantity per assembly is located in QTY. column. Unit of measure is always "each" unless specified otherwise in Quantity column. When Ref. is in QTY. column, this means that the Item Number is for information only and is not necessarily a service replacement part. Contact Frick Parts Department for more information. REV. (Revision) column tells the level of the engineering drawing parts were taken from. The P & I REF. column gives the reference number of the item as shown on the Piping and Instrumentation drawing. The Numerical Parts List can be used to locate a specific item in the Service Parts List.

Abbreviations found in this manual include:

A/R	As Required	SW	Socket Weld
HW	Hand Wheel	TSOC	Thermosyphon Oil Cooler
Ref.	Reference	WIL	Weld-In-Line
SC	Seal Cap	WCOC	Water Cooled Oil Cooler

The **Unit Data Plate** listing model/serial number etc., is normally located to the left of the microprocessor, attached to the frame below the compressor motor.

**NOTE: PLEASE PROVIDE FRICK ORDER NUMBER, UNIT MODEL NUMBER, AND UNIT SERIAL NUMBER WHEN REQUESTING A QUOTATION OR PLACING AN ORDER. FAILURE TO INCLUDE THIS INFORMATION MAY DELAY PROCESSING OF YOUR REQUEST.**

### Table of Contents

Figure 1. General Arrangement, Typical.....	4
Figure 2. Screw Compressor, Typical.....	6
Figure 3. Oil Separator, Typical.....	8
Figure 4. Oil Filter, Standard, Typical.....	12
Figure 5. Dual Oil Filter, Typical.....	13
Figure 6. Oil Filter, Standard, Current.....	14
Figure 7. Dual Oil Filter, Standard, Current.....	16
Figure 8. Piping and Instrumentation, Typical.....	18
Figure 9. Prelube Oil Pump Piping, Typical.....	22
Figure 10. Oil Cooler Piping, WCOC and TSOC, Typical.....	26
Figure 11. Oil Cooler Piping, WCOC and TSOC, Current.....	32
Figure 12. Full-Lube/Full-Cycling Oil Pump Piping, Typical.....	34
Figure 13. Liquid Injection Piping, Typical.....	38
Figure 14. Liquid Injection with Oil Pump, Current.....	42
Figure 15. 4" Multivalve.....	46
Figure 16. 5"—8" Multivalve.....	48
Figure 17. 10" and 14" Multivalve.....	52
Figure 18. 4 — 8" Multivalve, Current (Danfoss).....	56
Figure 19. 3" and 4" Discharge Stop/Check Valve (Frick).....	58
Figure 20. 5"—8" Discharge Stop/Check Valve (Frick).....	60
Figure 21. 3"—6" Discharge Stop Valve (Gram).....	64
Figure 22. 8 & 10" Discharge Stop Valve (Gram/Frick).....	68
Figure 23. Discharge Stop/Check Valve, Current (Danfoss).....	70
Figure 24. Discharge Stop/Check Valve (Gram).....	72
Figure 25. Economizer Kit.....	73
Figure 26. Transducer Manifold Assembly.....	74
Figure 27. Drive Coupling, Models 60—399.....	75
Figure 28. Drive Coupling, Models 177—270.....	76
Figure 29. Drive Coupling, Models 316—676.....	77
Figure 30. Drive Coupling, Models 496—856.....	78
Figure 31. 163/193mm Compressor Ports Locations.....	81
Figure 32. 233mm Compressor Ports Locations.....	82
Figure 33. 283mm Compressor Ports Locations.....	83
Figure 34. 355mm Compressor Ports Locations.....	84
FRICK FLANGE GASKETS.....	85
FRICK COMPRESSOR OILS.....	85
FRICK BLUE PAINT.....	85
MISCELLANEOUS TUBING AND CONNECTORS.....	86
ITEM NUMBER.....	86
DESCRIPTION.....	86
NUMERICAL PARTS LIST.....	87

**RECOMMENDED SPARE PARTS - CURRENT DESIGN**

DESCRIPTION	QTY.	MODEL	ITEM NUMBER
<b>UNIT:</b>			
Temperature Probe (TE-1—4)	1	ALL	640A0035H01
Transducer, Pressure, 0—200 PSIA*	1	ALL	913A0146H01
Transducer, Pressure, 0—500 PSIA*	1	ALL	913A0146H02
Potentiometer, Slide Stop	1	ALL	111Q0041148
Kit, Potentiometer, Slide Valve	1	ALL	534D0523G02
Valve, Solenoid, Slide Stop/Slide Valve, Vickers	1	ALL	951A0056H39
Coil For 951A0056H39 Above	1	ALL	951A0056H40
Heater, Oil, 500W, 120V	1	ALL	913A0047H01
Heater, Oil, 500W, 240V	1	ALL	913A0047H03
Filter, Coalescing, Standard	A/R	ALL	531B0019H01
Filter, Coalescing, Convolutud	A/R	ALL	531B0099H01
Gasket, Manway For Coalescer	1	60—76	531A0105H03
Gasket, Manway For Coalescer	1	100—856	531A0105H04
Element, Oil Filter, SuperFilter™ (Required for 1-2-3 Warranty)	A/R	ALL	531A0218H01
Gasket, End Cover for 531A0218H01 Above	A/R	ALL	959A0082H01
Gasket, Clamping Plate for 531A0218H01 Above	A/R	ALL	959A0053H01
Shaft Seal Replacement Kit**	1	60—76	534M0163G01
Shaft Seal Replacement Kit**	1	100—134	534M0163G02
Shaft Seal Replacement Kit**	1	177—270	534M0163G03
Shaft Seal Replacement Kit**	1	316—480	534M0163G04
Shaft Seal Replacement Kit	1	496—856	534M0163G05

**Note: This list is based on one unit. When stocking for more than one unit, the quantity should be adjusted to meet your individual requirements.**

\* Plus 649D4864H01 Replacement Cable for older units without DIN connector.

\*\* Also order Shaft Seal Housing Puller Kit 534C0289G01. This kit has all tools and hardware required for Models 60—480.

For help in identifying valves, see S160-800 SPL - Shutoff Valve Identification Guide.

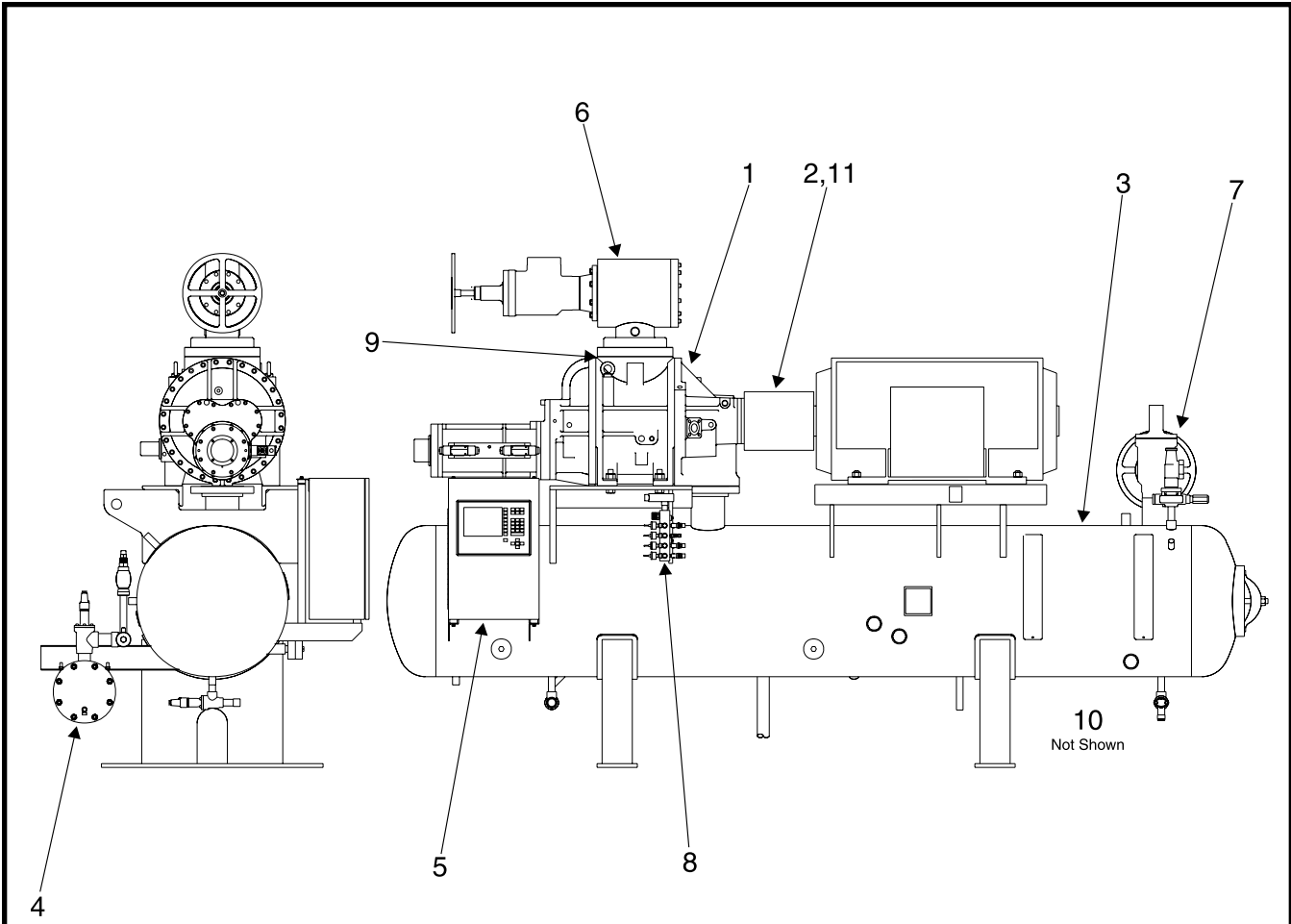

S/N BREAKS*	
RWB MODEL	S/N
60	W0475...
76	W0622...
100	W1107...
134	W1375...
177	W1133...
222	W0936...
270	W0134...
316	W0475...
399	W0316...
480	W0008...

\* These unit serial numbers show the beginnings of those that are manufactured as of 4/16/01. The changes include the Danfoss GVD Discharge Valve (Fig. 23), Demand Pump (Fig. 14), Plate Oil Cooler (Fig. 11), and Still Chamber/Dropleg on Separator. If your unit s/n is within 15 numbers of those above, and you cannot visually determine if it has the new technologies, contact the factory for assistance with identification. This publication also displays many parts breakdowns for units made prior to the above listing.

Figure 1. General Arrangement, Typical.

FIG. & INDEX	ITEM NUMBER	DESCRIPTION	QTY.	REV.	P & I REF.
1—	—	RWB II 60 & 76, Screw Compressor Unit	Ref.		
	720E0088	RWB II 100 & 134, R-22, Screw Compressor Unit	Ref.	—	
	720E0077	RWB II 177 & 222, Screw Compressor Unit (Shown)	Ref.	—	
	720E0090	RWB II 270, Screw Compressor Unit	Ref.	—	
	720E0086	RWB II 316 & 399, Screw Compressor Unit	Ref.	—	
	—	RWB II 480, Screw Compressor Unit	Ref.		
	720E0049	RWB II 496, Screw Compressor Unit	Ref.	—	
	720E0051	RWB II 676, Screw Compressor Unit	Ref.	—	
	720E0057	RWB II 856, Screw Compressor Unit	Ref.	—	
—1	—	Screw Compressor (See Figure 2)	1		C-1
—2	—	Coupling, Drive (See Figures 27—30)	1		CPL
—3	—	Oil Separator (See Figure 3)	1		
—4	—	Oil Filter Assembly (See Figures 4—7)	A/R		F-1
—5	—	Control Center (See Controls Publication S90-020M)	1		
—6	—	Multi-Valve Assembly, (See Figures 15—18)	1		
—7	—	Valve, Discharge Stop/Check, (See Figures 19 —24)	1		
—8	—	Transducer Manifold Assembly (See Figure 26)	Ref.		
—9	—	Gasket, Multivalve to Compressor (See Figure 2)	1		
—10	—	Oil Pump Piping (See Figures 9—14)	Ref.		
—11	—	Guard, Coupling	1		
	111Q0740012	Capscrew, Coupling Guard	A/R		

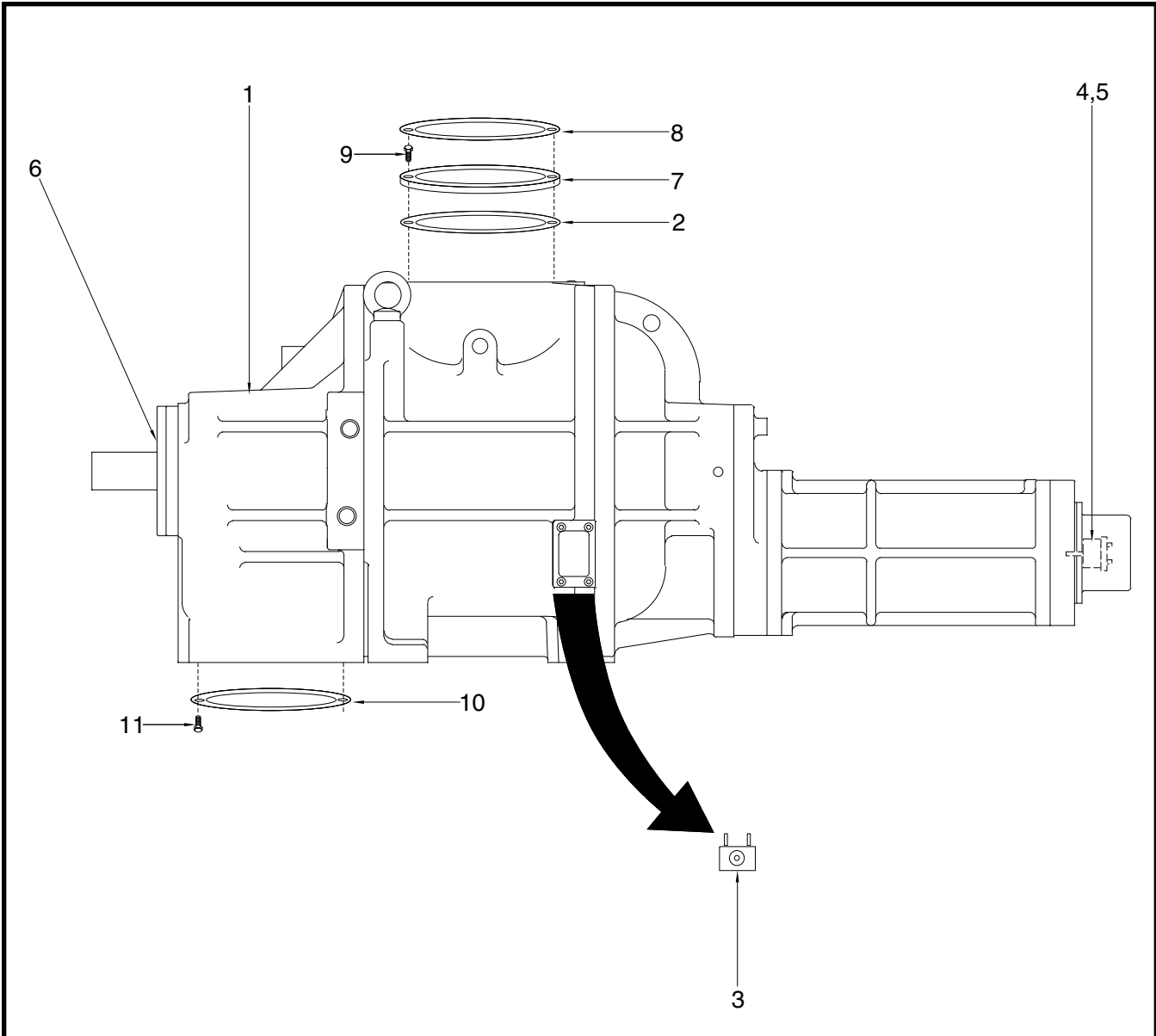

COMPRESSOR PART NUMBERS		
MODEL	NEW	REBUILT
TDSH163S	534E0168G01	534E0168S01
TDSH163L	534E0168G02	534E0168S02
TDSH193S	534E0169G01	534E0169S01
TDSH193L	534E0169G02	534E0169S02
TDSH233S	534E0170G01	534E0170S01
TDSH233L	534E0170G02	534E0170S02
TDSH233XL	534E0170G05	534E0170S05
TDSH283S	534D0575G01	534D0575S01
TDSH283L	534D0575G02	534D0575S02
TDSH283SX	534E0604G01	534E0604S01
TDSH355S	534E0309G02	534E0309S02
TDSH355L	534E0309G01	534E0309S01
TDSH355XL	534E0309G05	534E0309S05
TDSB355S	534E0645G01	534E0645S01
TDSB355L	534E0645G02	534E0645S02
TDSB355XL	534E0645G03	534E0645S03
TDSB355U	534D1170G01	534D1170S01

COMPRESSOR MOUNTING KITS*	
MODEL	PART NO.
60 & 76, 150 PSI	720M0234G01
60 & 76, 300 PSI	720M0234G02
100, 150 PSI	720M0234G03
100, 300 PSI	720M0234G04
134, 150 PSI	720M0234G05
134, 300 PSI	720M0234G06
177, 150 PSI	720M0234G07
177, 300 PSI	720M0234G08
222, 150 PSI	720M0234G09
222, 300 PSI	720M0234G10
270, 150 PSI	720M0234G11
270, 300 PSI	720M0234G12
316 - 480, 150 PSI	720M0234G13
316 - 480, 300 PSI	720M0234G14
496 - 856, 300 PSI	720M0234G15

\* Consists of gasket and shims to mount compressor.

Figure 2. Screw Compressor, Typical.

FIG. & INDEX	ITEM NUMBER	DESCRIPTION	QTY.	REV.	P & I REF.
2—	—	Screw Compressor	Ref.		C-1
—1	534E0168	TDSH 163S & L, Screw Compressor	1	W	
	534E0169	TDSH 193S & L, Screw Compressor	1	X	
	534E0170	TDSH 233S, L & XL, Screw Compressor	1	AB	
	534D0575	TDSH 283S & L, Screw Compressor	1	M	
	534E0604	TDSH 283SX, Screw Compressor	1	G	
	534E0309	TDSH 355S, L, XL, Screw Compressor	1	AF	
	534E0645	TDSB 355S, L & XL, Screw Compressor	1	L	
—2	959A0062H01	Gasket, Multivalve to Compressor, 150 PSI, 60 & 76	1		
	959A0062H21	Gasket, Multivalve to Compressor, 300 PSI, 60 & 76	1		
	959A0062H02	Gasket, Multivalve to Compressor, 150 PSI, 100	1		
	959A0062H22	Gasket, Multivalve to Compressor, 300 PSI, 100	1		
	959A0062H03	Gasket, Multivalve to Compressor, 150 PSI, 134 & 177	1		
	959A0062H23	Gasket, Multivalve to Compressor, 300 PSI, 134 & 177	1		
	959A0062H04	Gasket, Multivalve to Compressor, 150 PSI, 222	1		
	959A0062H24	Gasket, Multivalve to Compressor, 300 PSI, 222	1		
	959A0062H04	Gasket, 8—6" Adapter Plate to Compressor, 150 PSI, 222	1		
	959A0062H24	Gasket, 8—6" Adapter Plate to Compressor, 300 PSI, 222	1		
	959A0062H05	Gasket, Multivalve to Compressor, 150 PSI, 270—399	1		
	959A0062H25	Gasket, Multivalve to Compressor, 300 PSI, 270—399	1		
	959A0062H05	Gasket, 10—8" Adapter Plate to Compressor, 150 PSI, 316—480	1		
	959A0062H25	Gasket, 10—8" Adapter Plate to Compressor, 300 PSI, 316—480	1		
	959A0062H05	Gasket, Multivalve to Compressor, 150 PSI, 316—480	1		
	959A0054H36	Gasket, Multivalve to Compressor, 300 PSI, 496—856	1		
—3	111Q0041148	Kit, Slide Stop Potentiometer Replacement	1		
—4	534D0523G02	Kit, Slide Valve Potentiometer Replacement	1		
	534B0501H01	Potentiometer only	1		
—5	111Q0451313	Coupling, Flexible	1		
—6	534M0163G01	Kit, Shaft Seal, 163	1		
	534M0163G02	Kit, Shaft Seal, 193	1		
	534M0163G03	Kit, Shaft Seal, 233	1		
	534M0163G04	Kit, Shaft Seal, 283	1		
	534M0163G05	Kit, Shaft Seal, 355	1		
—7	535C0133H01	Plate, Adapter, 8 x 6", 222	1		
	535C0239H01	Plate, Adapter, 10 x 8", 316 & 480	1		
—8	959A0062H03	Gasket, 8 x 6" Adapter Plate to Multivalve, 150 PSI, 222	1		
	959A0062H23	Gasket, 8 x 6" Adapter Plate to Multivalve, 300 PSI, 222	1		
	959A0062H04	Gasket, 10 x 8" Adapter Plate to Multivalve, 150 PSI, 316—480	1		
	959A0062H24	Gasket, 10 x 8" Adapter Plate to Multivalve, 300 PSI, 316—480	1		
—9	111Q0740771	Capscrew, Socket Head, M16 x 45, 60 & 76	8		
	111Q0740748	Capscrew, Hex Head, M20 x 65, 100, 134	8		
	111Q0740746	Capscrew, Socket Head, M20 x 55, 222 (adapter to compr.)	8		
	111Q0740748	Capscrew, Hex Head, M20 x 65, 222 (multiv. to adapter)	8		
	111Q0740877	Capscrew, Hex Head, M20 x 80, 222	8		
	111Q0740772	Capscrew, Socket Head, M20 x 75, 316—480 (multiv. to adapter)	8		
	111Q0740797	Capscrew, Socket Head, M22 x 50, 316—480 (adapter to compr.)	12		
	111Q0740782	Capscrew, Hex Head, M22 x 75, 316—480	12		
	111Q0740808	Capscrew, Socket Head, M24 x 90, 316	16		
	111Q0740809	Capscrew, Hex Head, M30 x 100, 496 & 676	20		
—10	959A0054H28	Gasket, Discharge, 60 & 76	1		
	959A0054H30	Gasket, Discharge, 100 & 134	1		
	959A0054H32	Gasket, Discharge, 177—270	1		
	959A0054H33	Gasket, Discharge, 316—480	1		
	959A0054H34	Gasket, Discharge, 496—856	1		
—11	111Q0740792	Capscrew, M20 x 75, 60—134	8		
	111Q0740748	Capscrew, M20 x 65, 177—270	12		
	111Q0740782	Capscrew, M22 x 75, 316—480	12		
	111Q0740808	Capscrew, M24 x 90, 196—856	16		

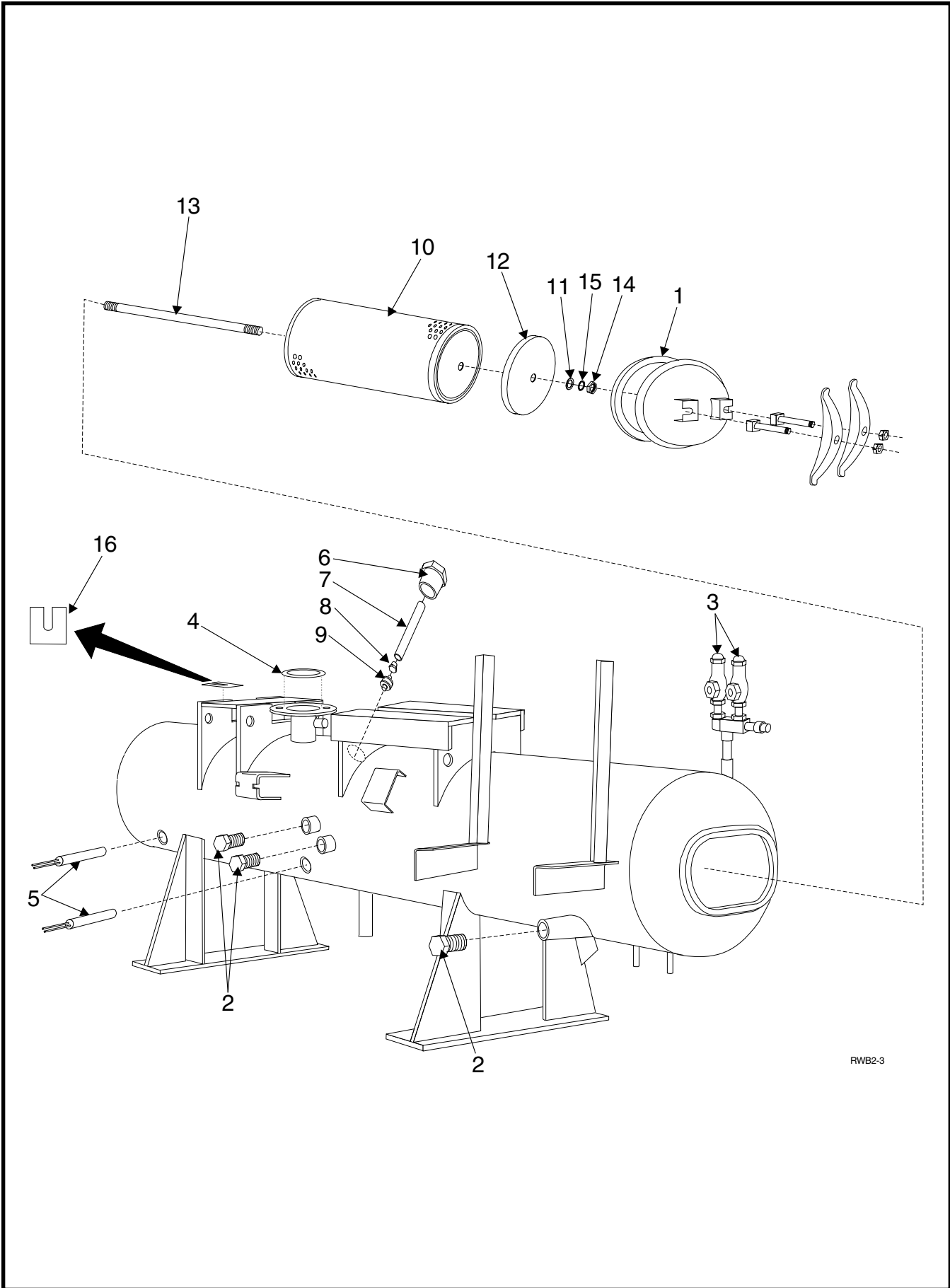

RWB2-3

Figure 3. Oil Separator, Typical.

FIG. & INDEX	ITEM NUMBER	DESCRIPTION	QTY.	REV.	P & I REF.
3—	548E0114G01	Oil Separator Assembly, 60 & 76	Ref.	R	
	548E0368G01	Oil Separator Assembly, 100 & 134	Ref.	—	
	548E0363G01	Oil Separator Assembly, 177 & 222	Ref.	—	
	548E0370G01	Oil Separator Assembly, 270	Ref.	—	
	548E0366G01	Oil Separator, 316 & 399	Ref.	—	
	548E0350G01	Oil Separator, 480	Ref.	B	
	548E0118G01	Oil Separator, 496	Ref.	L	
	548E0119G01	Oil Separator, 676	Ref.	L	
	548E0337G01	Oil Separator, 856	Ref.	A	
—1	531A0105H03	Gasket, Manway, 60 & 76	1		
	531A0105H04	Gasket, Manway, 100—856	1		
—2	947A0003H05	Glass, Sight	3		
—3	580C0358G09	Assembly, Dual Safety Valve	1		PSV-1
	955A0012H01	Manifold, 1/2"	1		
	952A0019H10	Valve, Safety, 803, 1/2" inlet, 3/4" outlet, 300 PSIG <sup>(1)</sup>	2		
	580C0357G09	Assembly, Dual Safety Valve	1		PSV-1
	955A0012H02	Manifold, 3/4"	1		
	952A0020H10	Valve, Safety, 804, 3/4" inlet, 1" outlet, 300 PSIG <sup>(1)</sup>	2		
	580C0361G09	Assembly, Dual Safety Valve	1		PSV-1
	955A0023H01	Manifold, 1"	1		
	952A0021H09	Valve, Safety, H3, 1" inlet, 1-1/4" outlet, 300 PSIG <sup>(1)</sup>	2		
	580C0362G09	Assembly, Dual Safety Valve	1		PSV-1
	955A0024H01	Manifold, 1-1/2"	1		
	952A0022H09	Valve, Safety, H5, 1-1/4" inlet, 2" outlet, 300 PSIG <sup>(1)</sup>	2		
	580C0400G10	Assembly, Dual Safety Valve	1		PSV-1
	955B0005H01	Valve, 107107, Shut-off, 3-Way, 1/2"	1		
	952A0051H10	Valve, Safety, 813, 1/2" inlet, 1" outlet, 300 PSIG <sup>(1)</sup>	2		
	580C0401G10	Assembly, Dual Safety Valve	1		PSV-1
	955A0041H02	Manifold, 849M, 1" inlet, 3/4" outlet	1		
	952A0052H10	Valve, Safety, 814, 3/4" inlet, 1-1/4" outlet, 300 PSIG <sup>(1)</sup>	2		
	580C0402G10	Assembly, Dual Safety Valve	1		PSV-1
	955B0005H03	Valve, Shut-off, 107563, 3-Way, 1"	1		
	952A0053H10	Valve, Safety, 815-TJ, 1" inlet, 1-1/2" outlet, 300 PSIG <sup>(1)</sup>	2		
	580C0403G07	Assembly, Dual Safety Valve	1		PSV-1
	955B0001H01	Manifold, 850M, 1-1/4" inlet, 3/4" FPT outlet	1		
	952A0054H07	Valve, Safety, 851, 3/4" inlet, 2" outlet, 300 PSIG <sup>(1)</sup>	2		
	580C0404G07	Assembly, Dual Safety Valve	1		PSV-1
	955B0001H02	Manifold, 850M, 1-1/4" inlet, 1" FPT outlet	1		
	952A0055H07	Valve, Safety, 851, 1" inlet, 2" outlet, 300 PSIG <sup>(1)</sup>	2		
	580C0405G07	Assembly, Dual Safety Valve	1		PSV-1
	955B0002H01	Manifold, 900ME, 2" inlet, 1-1/4" outlet	1		
	952A0056H07	Valve, Safety, 851, 1-1/4" inlet, 2" outlet, 300 PSIG <sup>(1)</sup>	2		
	580C0406G07	Assembly, Dual Safety Valve	1		PSV-1
	955B0002H01	Manifold, 900ME, 2" inlet, 1-1/4" outlet	1		
	952A0057H07	Valve, Safety, 901, 1-1/4" inlet, 3" outlet, 300 PSIG <sup>(1)</sup>	2		
580C0407G07	Assembly, Dual Safety Valve	1		PSV-1	
955B0002H02	Manifold, 900ME, 2" inlet, 1-1/2" outlet	1			
952A0058H07	Valve, Safety, 903, 1-1/2" inlet, 3" outlet, 300 PSIG <sup>(1)</sup>	2			

RWB II ROTARY SCREW COMPRESSOR UNIT  
SERVICE PARTS LIST



FIG. & INDEX	ITEM NUMBER	DESCRIPTION	QTY.	REV.	P & I REF.
3—	—	Oil Separator Assembly, Continued			
—4	959A0054H28	Gasket, Compressor to Separator, 60 & 76	1		
	959A0054H30	Gasket, Compressor to Separator, 100 & 134	1		
	959A0054H32	Gasket, Compressor to Separator, 177—270	1		
	959A0054H33	Gasket, Compressor to Separator, 316 & 480	1		
	959A0054H34	Gasket, Compressor to Separator, 496—856	1		
—5	913A0047H01	Heater, Oil, 500 Watts, 120 Volts	2-3		H-1,2
	913A0047H02	Heater, Oil, 1000 Watts, 120 Volts (Option)	2-3		H-1,2
	913A0047H03	Heater, Oil, 500 Watts, 240 Volts (Option)	2-3		H-1,2
	913A0047H04	Heater, Oil, 1000 Volts, 240 Volts (Option)	2-3		H-1,2
	111Q0451137	Box, Round, Conduit (not shown)	2-3		
	720A0013G01	Liquid Level Float Switch Assembly, 60 & 76 <sup>(2)</sup>	Ref.	—	
	720A0013G02	Liquid Level Float Switch Assembly, 100 & 134 <sup>(2)</sup>	Ref.	—	
	720A0013G03	Liquid Level Float Switch Assembly, 177 & 222 <sup>(2)</sup>	Ref.	—	
	720A0013G04	Liquid Level Float Switch Assembly, 270—480 <sup>(2)</sup>	Ref.	—	
	720A0013G05	Liquid Level Float Switch Assembly, 496 <sup>(2)</sup>	Ref.	—	
	720A0013G06	Liquid Level Float Switch Assembly, 676 & 856 <sup>(2)</sup>	Ref.	—	
—6	535A0015H01	Plug, Pipe, 2", Modified <sup>(2)</sup>	1		
—7	535A0181H01	Rod, Extension, 17.44", 60 & 76 <sup>(2)</sup>	1		
	535A0181H02	Rod, Extension, 21.44", 100 & 134 <sup>(2)</sup>	1		
	535A0181H03	Rod, Extension, 27.44", 177 & 222 <sup>(2)</sup>	1		
	535A0181H04	Rod, Extension, 33.44", 316 & 480 <sup>(2)</sup>	1		
	535A0181H05	Rod, Extension, 39.44", 496 <sup>(2)</sup>	1		
	535A0181H08	Rod, Extension, 45.44", 676 & 856 <sup>(2)</sup>	1		
—8	944A0010H01	Bushing, 1/4" MPT x 1/8" FPT <sup>(2)</sup>	1		
—9	536A1419H01	Switch, Liquid Level <sup>(3)</sup>	1		LS-1
	535M0144G01	Filter Assy., Coalescing, Standard, 60—480 & 856	Ref.		
	535M0145G01	Filter Assy., Coalescing, Convoluted, 60—480 & 856	Ref.		
	535B0019G05	Filter Assy., Coalescing, Convoluted, 496	Ref.	C	
	535B0019G06	Filter Assy., Coalescing, Convoluted, 676	Ref.	C	
—10	531B0019H01	Filter, Coalescing, Standard, 60 & 76 <sup>(4)</sup>	1		
	531B0019H01	Filter, Coalescing, Standard, 100 & 134 <sup>(4)</sup>	2		
	531B0019H01	Filter, Coalescing, Standard, 177 & 222 <sup>(4)</sup>	3		
	531B0019H01	Filter, Coalescing, Standard, 270—480 <sup>(4)</sup>	4		
	531B0099H01	Filter, Coalescing, Convoluted, 496	5		
	531B0099H01	Filter, Coalescing, Convoluted, 676	9		
	531B0099H01	Filter, Coalescing, Convoluted, 856	11		
—11	540D0217H06	Washer, Seal	1 per		
—12	540D0217G02	Retainer, Filter	1 per		
—13	540D0217G03	Stud 1/2-13NC x 37"	1 per		

FIG. & INDEX	ITEM NUMBER	DESCRIPTION	QTY.	REV.	P & I REF.
—14	902A0021H01	Nut, Hex 1/2-13NC	1 per		
—15	111Q0940051	Washer 1/2"	1 per		
—16	531A0048G35	Shim Kit, Compressor, 60 & 76	2		
	531A0048G40	Shim Kit, Compressor, 60 & 76	1		
	531A0048G36	Shim Kit, Compressor, 100 & 134	2		
	531A0048G41	Shim Kit, Compressor, 100 & 134	1		
	531A0048G37	Shim Kit, Compressor, 177—270	4		
	531A0048G38	Shim Kit, Compressor, 316 & 480	4		
	531A0048G39	Shim Kit, Compressor, 496—856	4		
		1. When replacing Relief Valves, check for correct inlet and outlet connection size and model. When replacing Frick ST, LST, or AF Safety Valves, see Service Information Letter NS-30-95, or contact factory for correct size.			
		2. Used with Prelube, Full-Cycling, and Demand Oil Pump, or no pump.			
		3. Used with Prelube, Full-Cycling, and Demand Oil Pump, or no pump. (Replaces 913A0086H01, 913A0086H02, 913A0063H03 and 913A0055H01/02)			
		4. Optional Convoluted Filter - 531B0065H01.			

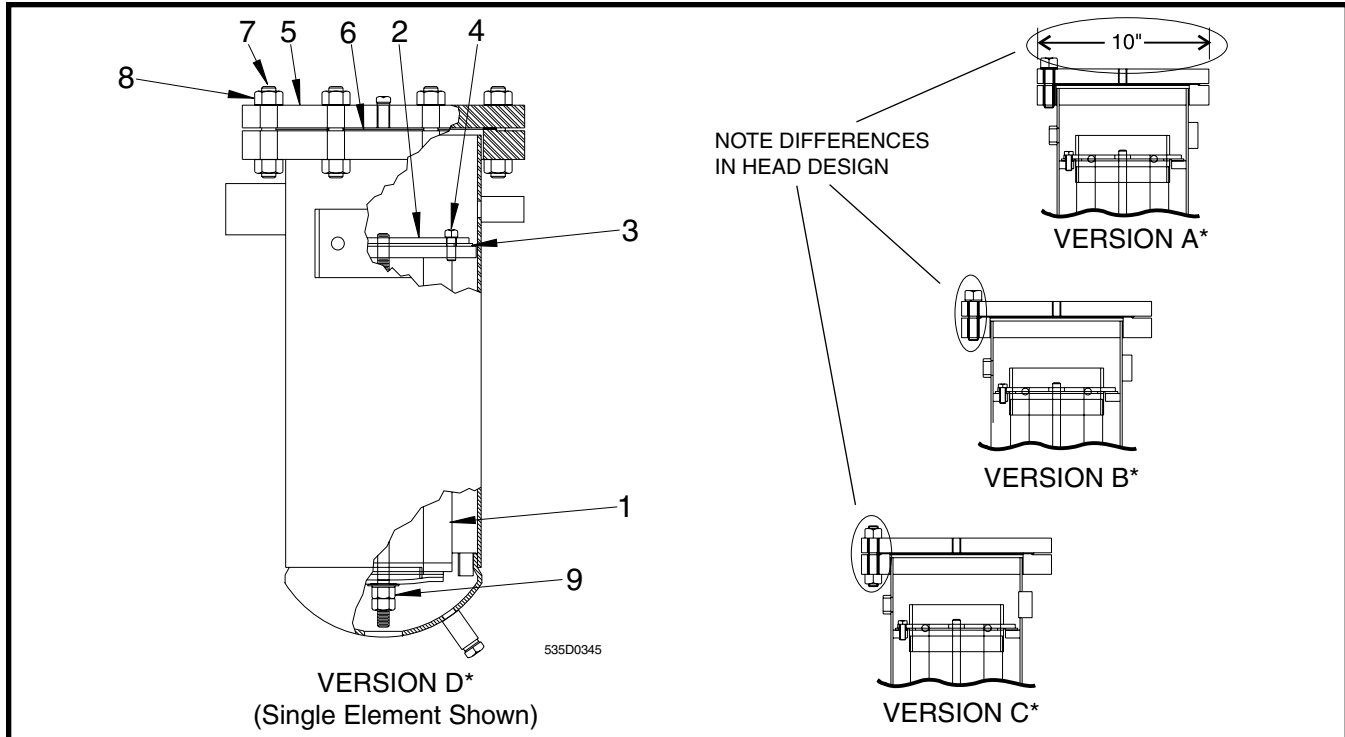
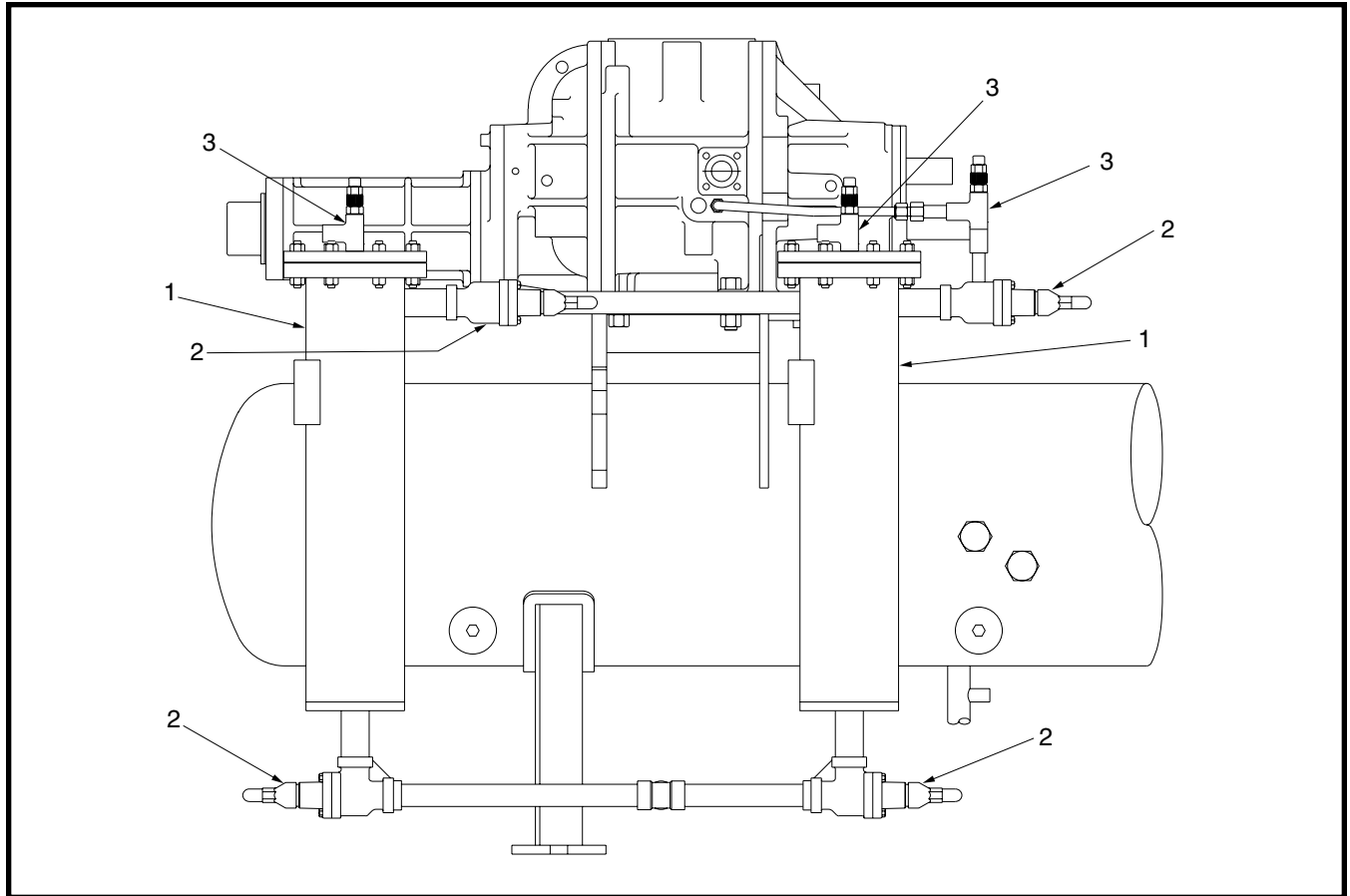

Figure 4. Oil Filter, Standard, Typical.

FIG. & INDEX	ITEM NUMBER	DESCRIPTION	QTY.	REV.	P & I REF.
4—	535D0345G01	Oil Filter Assembly, 1 Element, 60 & 76 (Version D)	Ref.	A	F-1,2
	535D0335G01	Oil Filter Assembly, 2 Element, 100—222 1-1/2" (Version D)	Ref.	A	F-1,2
	535D0346G01	Oil Filter Assembly, 2 Element, 100—222 2" (Version D)	Ref.	A	F-1,2
	535D0347G01	Oil Filter Assembly, 3 Element, 270—856 2-1/2" (Version D)	Ref.	A	F-1,2
	535D0524G01	Oil Filter Assembly, 3 Element, 270—856 3" (Version D)	Ref.	—	F-1,2
—1	531A0028H01	Element, Oil Filter, 15 Micron	A/R		
	531A0218H01	Element, Oil Filter, SuperFilter™ (Required for 1-2-3 Warranty)	A/R		
—2	535A0144H01	Plate, Clamping	1		
—3	959A0053H01	Gasket, Clamping Plate (Version B, C & D)	1		
—4	901A0043D05	Capscrew, Hex Head, 3/8 NC x 1"	6		
—5	535A0351H01	Cover, End	1		
—6	531A0205H01	Gasket, End Cover (Version A)	1		
	959A0063H01	Gasket, End Cover (Version B)	1		
	959A0082H01	Gasket, End Cover (Version C & D)	1		
—7	901A0098H11	Stud, 5/8 NC x 4"	8		
—8	902A0021H03	Nut, High Tensile, 5/8" NC	16		
—9	535M0049G01	Kit, Oil Filter Hardware, 1 Element	1		
	535M0049G02	Kit, Oil Filter Hardware, 2 Elements	1		
	535M0049G03	Kit, Oil Filter Hardware, 3 Elements	1		
		Consisting of standard hardware plus:			
	900A0008H01	Yoke	1		
	333Q0001236	Gasket	1		
	900A0007H01	Center Seal, 2 Elements	1		
	900A0007H01	Center Seal, 3 Elements	2		
<p>* VERSION A: 10" diameter head, threaded flange, flat bottom.                      * VERSION B: threaded flange w/hex head capscrews, flat or rounded bottom.                      * VERSION C: drilled flange w/studs and nuts, flat bottom.                      * VERSION D: drilled flange w/studs and nuts, rounded bottom. Version D, 1-1/2" with 2 drains, is 535D0518G01.                      NOTE: Item numbers 1 &amp; 9, apply to all four versions. Items 2—8 are for Version D.</p>					



**Figure 5. Dual Oil Filter, Typical.**

FIG. & INDEX	ITEM NUMBER	DESCRIPTION	QTY.	REV.	P & I REF.
5—	720D0057G01	Dual Oil Filter Assy., 60 & 76	Ref.	E	
	720D0234G01	Dual Oil Filter Assy., 100 & 134	Ref.	B	
	720D0095G01	Dual Oil Filter Assy., 177 & 222	Ref.	E	
	720D0083G01	Dual Oil Filter Assy., 270	Ref.	G	
	535C0183G01	Dual Oil Filter Assy., 316 & 399	Ref.	E	
	720D0247G01	Dual Oil Filter Assy., 480	Ref.	A	
	720D0104G01	Dual Oil Filter Assy., 496	Ref.	D	
	720D0117G01	Dual Oil Filter Assy., 676	Ref.	D	
	720D0216G01	Dual Oil Filter Assy., 856	Ref.	B	
	—1	535D0345G01	Oil Filter Assembly, 1 Element, (See Figure 4)	Ref.	A
535D0335G01		Oil Filter Assembly, 2 Element, 1-1/2" Connections (See Fig. 4)	Ref.	A	F-1,2
535D0518G01		Oil Filter Assembly, 2 Element, 1-1/2" Connections (See Fig. 4)	Ref.	A	F-1,2
535D0346G01		Oil Filter Assembly, 2 Element, 2" Connections (See Fig. 4)	Ref.	A	F-1,2
535D0347G01		Oil Filter Assembly, 3 Element, 2-1/2" (See Figure 4)	Ref.	A	F-1,2
535D0524G01		Oil Filter Assembly, 3 Element, 3" (See Figure 4)	Ref.	—	F-1,2
—2	950A0233H05	Valve, Angle, Socket Weld, Seal Cap, 1-1/2"	4		
	950A0233H06	Valve, Angle, Socket Weld, Seal Cap, 2"	4		
	950A0241H07	Valve, Angle, Weld-In-Line, Seal Cap, 2-1/2"	4		
	950A0241H08	Valve, Angle, Weld-In-Line, Seal Cap, 3"	4		
—3	957A0003H01	Valve, Angle, Seal Cap, 1/4" NPT	2		



FIG. & INDEX	ITEM NUMBER	DESCRIPTION	QTY.	REV.	P & I REF.
6—	—	Assembly, Single Oil Filter	Ref.	—	
—1	553E0005	Assembly, Filter, 60 & 76	1		
	553E0001	Assembly, Filter, 100 & 134	1		
	553E0004	Assembly, Filter, 177 & 222	1		
	553E0003	Assembly, Filter, 270—399	1		
	553E0007	Assembly, Filter, 856	1		
—2	959A0082H01	Gasket	1		
—3	553A0001H01	Cover, End	1		
—4	901A0098H11	Stud, 5/8-11 x 4"	8		
—5	902A0021H03	Nut, 5/8-11 UNC	16		
—6	535A0144H01	Plate, Clamping	1		
—7	959A0053H01	Gasket	1		
—8	901A0043D05	Capscrew, Hex Head, 3/8-16 x 1"	6		
—9	333Q0001268	Rod, Threaded, 1/2-13 x 31-1/2"	1		
—10	531A0218H01	Element, Oil Filter, SuperFilter™ (Required for 1-2-3 Warranty)	1-3		
—11	900A0007H01	Seal, Center	1-2		
—12	900A0008H01	Yoke, Bottom	1		
—13	333Q0001236	Gasket	1		
—14	905A0007H05	Washer, Flat, 1/2"	1		
—15	333Q0001237	Washer, Starlock, 1/2"	1		
—16	902A0021H01	Nut, 1/2-13 UNC	2		
—17	957A0003H01	Valve, Angle, SC, 1/4" NPT	3		
	913A0102H02	Transducer, Pressure, 0—500 PSIA	2		PE-1,2
—18	950A0233H05	Valve, Angle, SC, 1-1/2" SW, 100 & 134	1		
	950A0233H06	Valve, Angle, SC, 2" SW, 177 & 222	1		
	950A0241H07	Valve, Angle, SC, 2-1/2" BW, 270—676	1		
	950A0241H08	Valve, Angle, SC, 3" BW, 856	1		
—19	954A0033H01	Valve, Angle, SC, Hand Expansion, 1" SW, 100—134	1		
	954A0033H02	Valve, Angle, SC, Hand Expansion, 1-1/4" SW, 177—222	1		
	954A0047H01	Valve, Angle, SC, Hand Expansion, 1-1/2" SW, 270—676	1		
	954A0047H02	Valve, Angle, SC, Hand Expansion, 2" SW, 856	1		

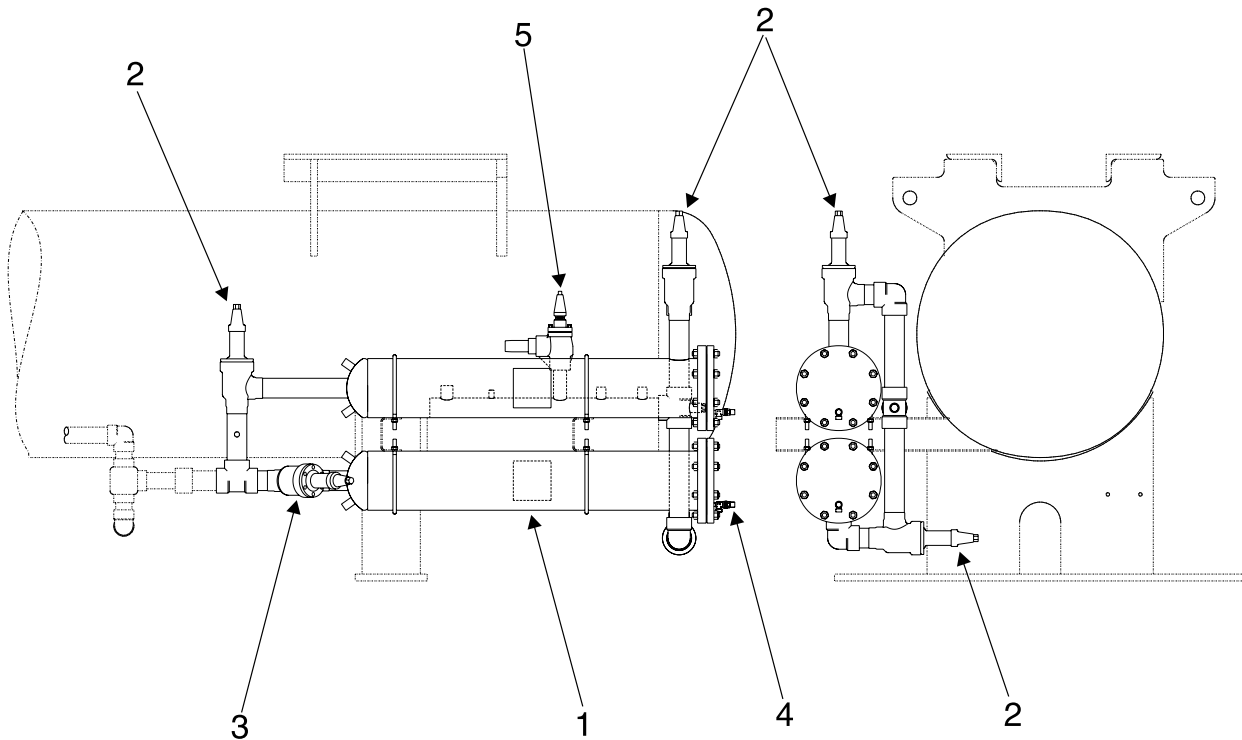
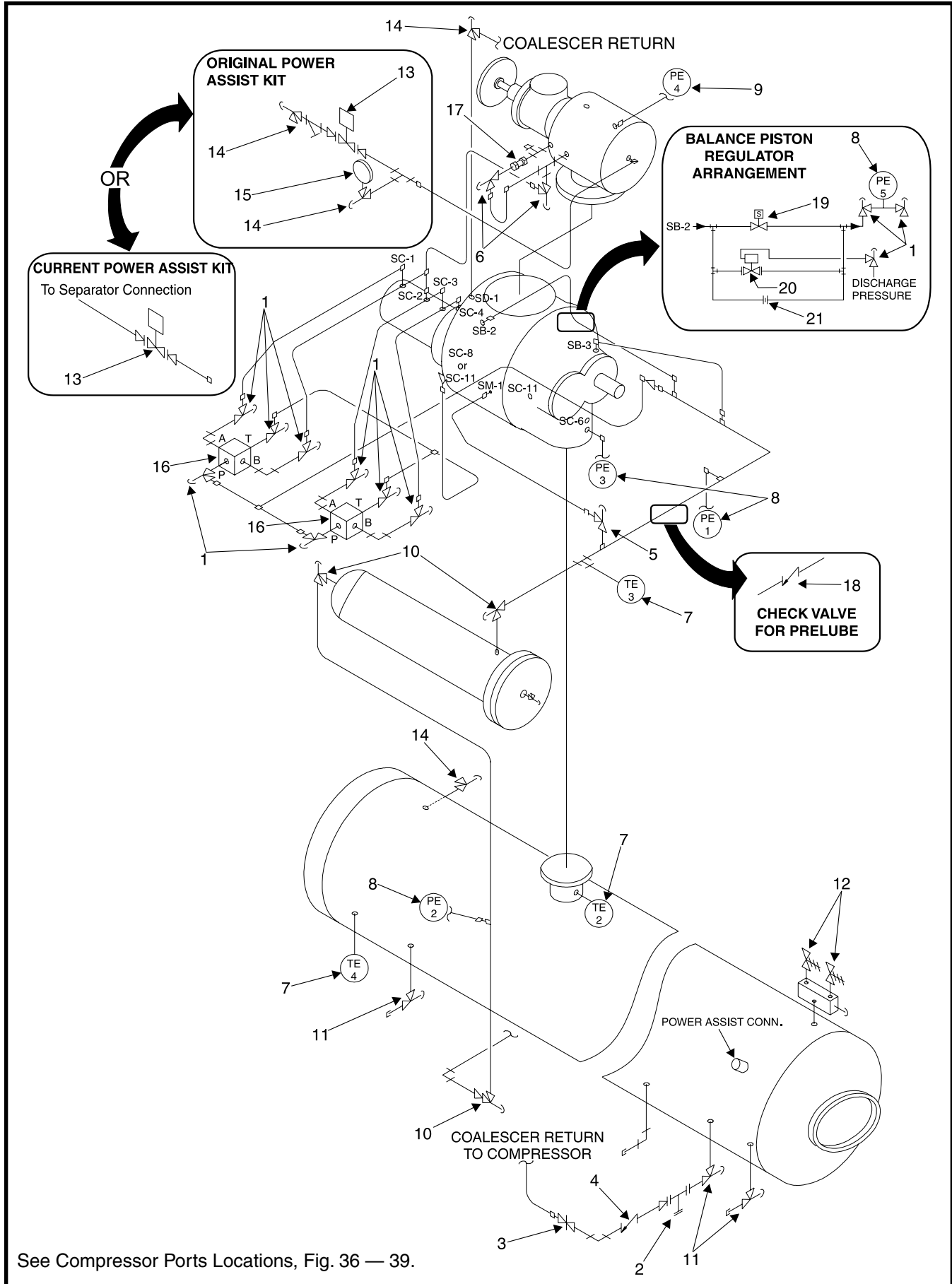

Figure 7. Dual Oil Filter, Standard, Current.

FIG. & INDEX	ITEM NUMBER	DESCRIPTION	QTY.	REV.	P & I REF.
7—	—	Dual Oil Filters, 60 and 76	Ref.	—	
	720D0234	Dual Oil Filters, 100 and 134	Ref.	—	
	720D0343	Dual Oil Filters, 177 and 222	Ref.	—	
	720D0356	Dual Oil Filters, 270—399 (Shown)	Ref.	—	
	—	Dual Oil Filters, 480	Ref.	—	
—1	553E0005	Assembly, Filter, 60 & 134	2		
	553E0006	Assembly, Filter, 100 & 134	2		
	553E0004	Assembly, Filter, 177 & 222	2		
	553E0003	Assembly, Filter, 270—399	2		
	553E0007	Assembly, Filter, 856	2		
—2	950A0233H05	Valve, Angle, SC, 1-1/2" SW, 100 & 134	3		
	950A0233H06	Valve, Angle, SC, 2" SW, 177 & 222	3		
	950A0241H07	Valve, Angle, SC, 2-1/2" BW, 270—399	3		
—3	950A0245H05	Valve, Globe, SC, 1-1/2" SW, 100 & 134	1		
	950A0245H06	Valve, Globe, SC, 2" SW, 177 & 222	1		
	950A0253H07	Valve, Globe, SC, 2-1/2" BW, 270—399	1		
—4	957A0003H01	Valve, Angle, SC, 1/4" NPT	2		
—5	954A0033H01	Valve, Hand Expansion, SC, 1" SW, 100—134	1		
	954A0033H02	Valve, Hand Expansion, SC, 1-1/4" SW, 177—222	1		
	954A0047H01	Valve, Hand Expansion, SC, 1-1/2" SW, 270—399	1		



See Compressor Ports Locations, Fig. 36 — 39.

Figure 8. Piping and Instrumentation, Typical.

FIG. & INDEX	ITEM NUMBER	DESCRIPTION	QTY.	REV.	P & I REF.
8—	—	Package Parts Assembly, R-717, Models 60 & 76Ref.			
	—	Package Parts Assembly, R-22, Models 60 & 76Ref.			
	720E0088G40	Package Parts Assembly, R-717, Models 100 & 134Ref.			
	720E0088G40	Package Parts Assembly, R-22, Models 100 & 134Ref.			
	720E0077G40	Package Parts Assembly, R-717, Models 177 & 222Ref.			
	720E0077G40	Package Parts Assembly, R-22, Models 177 & 222Ref.			
	720E0090G40	Package Parts Assembly, R-717, Model 270Ref.			
	720E0090G50	Package Parts Assembly, R-22, Models 270Ref.			
	720E0086G40	Package Parts Assembly, R-717, Models 316 & 399Ref.			
	720E0086G50	Package Parts Assembly, R-22, Models 316 & 399Ref.			
	—	Package Parts Assembly, R-717, Model 480Ref.			
	—	Package Parts Assembly, R-22, Model 480Ref.			
	720E0049G40	Package Parts Assembly, R-717, Model 496Ref.L			
	720E0050G40	Package Parts Assembly, R-22, Model 496Ref.L			
	720E0051G40	Package Parts Assembly, R-717, Model 676Ref.K			
	720E0052G40	Package Parts Assembly, R-22, Model 676Ref.K			
—1	957A0003H01	Valve, Angle, Seal Cap, 1/4" NPTA/R			
—2	950A0019H01	Strainer, 1/2" FPT1			
	950A0019H02	Gasket, Flange1			
	950A0019H03	Gasket, Screen1			
	950A0019H04	Screen w/Gasket1			
—3	955A0008H01	Valve, Needle, 1/4" NPT1NV			
—4	956A0018H01	Valve, Check, 1/4" NPT1			
—5	954A0032H01	Valve, Angle, Hand Expansion, Seal Cap, 1/2" S.W.1			
	954A0032H02	Valve, Angle, Hand Expansion, Seal Cap, 3/4" S.W.1			
	954A0033H01	Valve, Angle, Hand Expansion, Seal Cap, 1" S.W.1			
	954A0033H02	Valve, Angle, Hand Expansion, Seal Cap, 1-1/4" S.W.1			
	954A0047H01	Valve, Angle, Hand Expansion, Seal Cap, 1-1/2" S.W.1			
—6	957A0003H02	Valve, Angle, Seal Cap, 3/8" NPTA/R			
—7	111Q0280818*	Sensor, Temperature, 3/16 x 4", <b>Version A</b> 4TE1-4			
	990A0014H01	Well, Temperature Sensor, 3/4" NPT, Original4			
	980A0017H01	Washer, Neoprene, for 111Q02808184			
	640A0035H01*	Sensor, Temperature, 5/16 x 1", <b>Version B</b> 4TE1-4			
	990A0062H01	Well, Temperature Sensor, 3/4" NPT, Current4			
	640A0038H10	Tube, Retainer, Current Temperature Sensor (cut to length)4			
	640A0051H01	Spring, Retainer, Tube (Stonco, 1-3/8" to $C_L$ of eye)4			
	640A0033H01	Spring, Retainer, Tube (RAB, 7/8" to $C_L$ of eye)4			

\*Version A used prior to 8/97. Version B used from 8/97 to current.

**RWB II ROTARY SCREW COMPRESSOR UNIT  
 SERVICE PARTS LIST**



FIG. & INDEX	ITEM NUMBER	DESCRIPTION	QTY.	REV.	P & I REF.
8—	—	Piping and Instrumentation, Continued	Ref.		
—8	913A0146H05	Transducer, Pressure, 0-300 PSIA*	3		PE1,2,3,5
	913A0146H02	Transducer, Pressure, 0-500 PSIA, (Quantum)*	3		PE1,2,3,5
	* Plus 649D4864H01 Replacement Cable for older units without DIN connector.				
—9	913A0146H04	Transducer, Pressure, 0-100 PSIA*	1		PE-4
	913A0146H01	Transducer, Pressure, 0-200 PSIA (Quantum)*	1		PE-4
	913A0146H05	Transducer, Pressure, 0-300 PSIA*	3		PE-4
	* Plus 649D4864H01 Replacement Cable for older units without DIN connector.				
—10	950A0233H05	Valve, Angle, Seal Cap, 1-1/2" S.W.	3		
	950A0233H06	Valve, Angle, Seal Cap, 2" S.W.	3		
	950A0241H07	Valve, Angle, Seal Cap, 2-1/2" W.I.L.	3		
—11	950A0233H01	Valve, Angle, Seal Cap, 1/2" S.W.	3		
—12	—	Assembly, Dual Safety Valve (See Figure 3)	1		
	580M0096G01	Parts, Power Assist, Multivalve, (original)	Ref.		
	535M0146G01	Parts, Power Assist, Multivalve, (current)	Ref.		
—13	951A0060H04	Valve, Solenoid, less coil (Parker Hannifin)(original)	1		SV-9
	951A0060H05	Coil, Solenoid, 110/120V	1		
	951A0060H06	Coil, Solenoid, 220/240V	1		
	951A0006H14	Valve, Solenoid, with strainer, less coil (R/S)(current)	1		SV-9
	333Q0001099	Housing, Coil	1		
	951A0009H01	Coil, Solenoid, 115-60	1		
	951A0009H03	Coil, Solenoid, 220-60	1		
	950A0001H02	Strainer (R/S)	1		
	950A0001H21	Screen Kit (incl. screen, cover & gasket)	1		
	950A0001H31	Flange Gasket	2		
	951A0006H07	Valve, Solenoid, less strainer, less coil (R/S)(current)	1		SV-9
	333Q0001099	Housing, Coil	1		
	951A0009H01	Coil, Solenoid, 115-60	1		
	951A0009H03	Coil, Solenoid, 220-60	1		
	951A0009H05	Coil, Solenoid, 230-50	1		
	951A0009H07	Coil, Solenoid, 115-50	1		
—14	957A0003H01	Valve, Angle, Seal Cap, 1/4"	4		
—15	990A0003H02	Gauge, Pressure, 30" Vac.—150 PSIG	1		
—16	951A0056H39	Valve, Solenoid, 120-60, 110-50, Vickers *	2		SV1-4
	951A0056H41	Valve, Solenoid, 240-60, 220-50, Vickers *	2		
	951A0056H43	Valve, Solenoid, 240-50, Vickers *	2		
	951A0056H34	Seal Kit, Solenoid Valve, Vickers	2		
	951A0056H40	Coil, 120-60, 110-50	4		
	951A0056H42	Coil, 240-60, 220-50	4		
	951A0056H44	Coil, 240-50	4		
	333Q0000517	Kit, Capscrew, Socket Head, 10/24 x 1-1/4", RXF 12—19	2		
	111Q0740878	Capscrew, Socket Head, M5 x 30mm, RXF 24—50	8		
	535A0292H05	Subplate, Vickers Control Valve	2		

\* Frick recommends that Continental Valves be replaced with Vickers Valves when capacity control valve components are required. Order 580M0128R01 Vickers Valve Retrofit Kit, which includes the valve (120VAC) and attaching hardware. For other than standard 120VAC, consult factory. Note that coils are not interchangeable between Vickers and Continental.

FIG. & INDEX	ITEM NUMBER	DESCRIPTION	QTY.	REV.	P & I REF.
—17	956A0031H07	Valve, Check, 10 PSIG, 3/8" (Booster or Swing)	1		
	956A0031H03	Valve, Check, 15 PSIG, 3/8" (Booster or Swing)	1		
	945A0031H01	Valve, Check, 20 PSIG, 3/8" (High Stage Applications)	1		
	956A0031H11	Valve, Check, 40 PSIG, 3/8" (High Stage Applications)	1		
	956A0031H08	Valve, Check, 10 PSIG, 1/2" (Booster or Swing)	1		
	956A0031H04	Valve, Check, 15 PSIG, 1/2" (Booster or Swing)	1		
	956A0031H02	Valve, Check, 20 PSIG, 1/2" (High Stage Applications)	1		
	956A0031H12	Valve, Check, 40 PSIG, 1/2" (High Stage Applications)	1		
—18	956A0012G06	Valve, Check, 1-1/4" SW	1		
	956A0012G03	Valve, Check, 1-1/2" SW	1		
	956A0012G01	Valve, Check, 2" SW	1		
	956A0012G05	Valve, Check, 2-1/2" SW	1		
	535M0093G01	Balance Piston Regulator Arrangement, 496—856	Ref.		
—19	951A0007H07	Valve, Solenoid, Less Coil	1		SV-8
	951A0009H01	Coil, Solenoid, 110/120V	1		
—20	954A0014H01	Regulator, Differential Pressure	1		
—21	534B0325H01	Plug, Orifice	1		

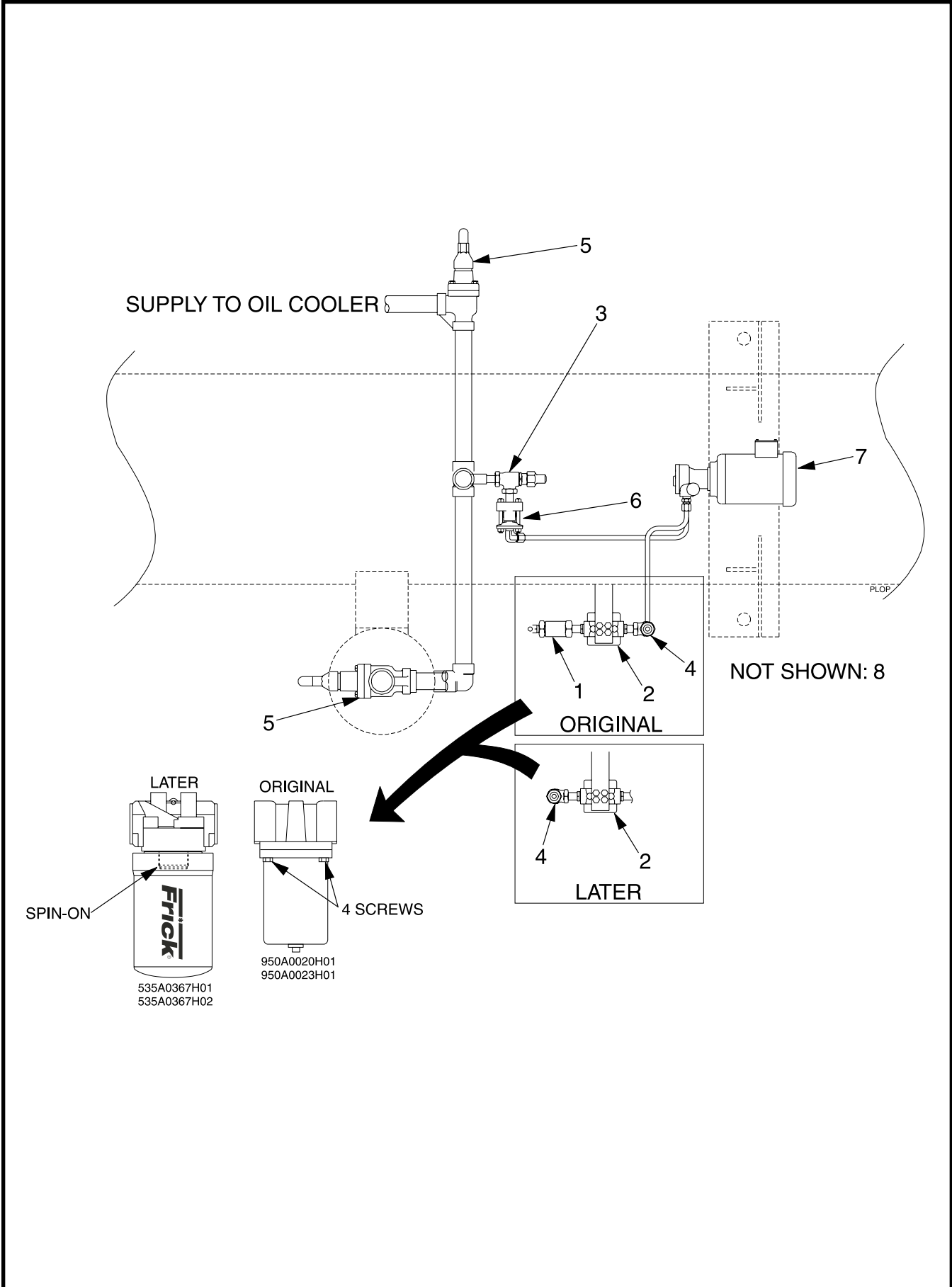

Figure 9. Pre-lube Oil Pump Piping, Typical.

FIG. & INDEX	ITEM NUMBER	DESCRIPTION	QTY.	REV.	P & I REF.
9—	720M0071	Prelube Oil Pump Piping, 60 & 76	Ref.		
	720M0152	Prelube Oil Pump Piping, 100 & 134	Ref.		
	720M0053	Prelube Oil Pump Piping, 177 & 222	Ref.		
	720M0051	Prelube Oil Pump Piping, 270	Ref.		
	720M0061	Prelube Oil Pump Piping, 316, 399, 480	Ref.		
	720M0022	Prelube Oil Pump Piping, 270, 316, 399, 480	Ref.		
	720M0080	Prelube Oil Pump Piping, 496	Ref.		
	720M0089	Prelube Oil Pump Piping, 676	Ref.		
	535M0101	Prelube Oil Pump and Motor, 60 & 76	Ref.		
	720M0003	Prelube Oil Pump and Motor, 100, 134, 177 & 222	Ref.		
	720M0022	Prelube Oil Pump and Motor, 270, 316, 399 & 480	Ref.		
	720M0079	Prelube Oil Pump and Motor, 496 & 676	Ref.		
	720D0046	Prelube Oil Pump Fittings, 60 & 76	Ref.	G	
	720D0227	Prelube Oil Pump Fittings, 100 & 134	Ref.	B	
	720D0084	Prelube Oil Pump Fittings, 177 & 222	Ref.	H	
	720D0072	Prelube Oil Pump Fittings, 270	Ref.	H	
	720D0105	Prelube Oil Pump Fittings, 316 & 399	Ref.	E	
	720D0236	Prelube Oil Pump Fittings, 480	Ref.	A	
	720D0118	Prelube Oil Pump Fittings, 496	Ref.	D	
	720D0125	Prelube Oil Pump Fittings, 676	Ref.	D	
—1	956A0014H03	Valve, Check, 1/2" FPT, 60 — 222	1		
	956A0012G04	Valve, Check, 1-1/4" FPT, 270—399	1		
—2	950A0020H01	Filter, In-Line, 60 —222 (Original)	1		F-3
	980A0012B66	O-ring, In-Line Filter	1		
	950A0020H02	Cartridge, In-Line Filter (Remove 4 screws to replace)	1		
	535A0367H02	Filter, In-line, 60—222 (Current)	1		F-3
	535A0368H02	Element, In-Line Spin-on Filter, SuperFilter™ II	1		
	950A0023H01	Filter, In-Line, 270—676 (Original)	1		F-3
	980A0012B76	O-ring, In-Line Filter	1		
	950A0023H02	Cartridge, Replacement (Remove 4 screws to replace)	1		
	535A0367H01	Filter, In-Line, 270—676 (Current)	1		F-3
535A0369H02	Element, In-Line Spin-on Filter, SuperFilter™ II	1			
—3	950A0236H02	Valve, Angle, Seal Cap, 3/4" NPT, 60—222	1		
	950A0237H04	Valve, Angle, Seal Cap, 1-1/4" NPT, 270—480	1		
	950A0233H05	Valve, Angle, Seal Cap, 1-1/2" SW, 316—676	1		
—4	950A0237H01	Valve, Angle, Seal Cap, 1/2" NPT, 60—399	1		
—5	950A0241H05	Valve, Angle, Seal Cap, 1-1/2" WIL, 60—134	2		
	950A0233H05	Valve, Angle, Seal Cap, 1-1/2" SW, 60—134	2		
	950A0241H06	Valve, Angle, Seal Cap, 2" WIL, 177—222	2		
	950A0233H06	Valve, Angle, Seal Cap, 2" SW, 177—222	2		
	950A0241H07	Valve, Angle, Seal Cap, 2-1/2" WIL, 270—676	2		

RWB II ROTARY SCREW COMPRESSOR UNIT  
SERVICE PARTS LIST



FIG. & INDEX	ITEM NUMBER	DESCRIPTION	QTY.	REV.	P & I REF.
9—	—	Prelube Oil Pump Piping, Continued	Ref.		
—6	950A0019H01	Strainer, 100 Mesh, 1/2" NPT, 60—222	1		
	950A0019H02	Gasket, Flange	1		
	950A0019H03	Gasket, Screen	1		
	950A0019H04	Screen w/Gasket	1		
	951A0037H16	Strainer, 40 Mesh, 1-1/2" Fig., 270—399	1		
	951A0037H26	Screen only	1		
	951A0037H36	Gasket, Screen	1		
	950A0001H08	Strainer, 60 Mesh, 1-1/2" Fig., 480, 676	1		
	950A0001H34	Gasket, Flange	1		
	950A0001H40	Gasket, Screen	1		
	950A0001H27	Screen & Spring w/Gasket	1		
	950A0069H07	Strainer, 60 Mesh, 1-1/2" S.W., 270—496	1		
	950A0069H25	Gasket, Screen	1		
	950A0069H37	Screen only	1		
—7	960A0043H03	Oil Pump and Motor, 60—222	1		
	960A0043H20	Pump, 2-LEVCC-A-5 (960A0043H53 Rebuilt)	1		
	960A0043H51	O-ring (Shaft Seal)	1		
	914A0057H02	Motor, 3/4 HP, (230/460-3-60)(190/380-3-50)	1		
	960A0043H11	Coupling, Drive	1		
	960A0043H04	Oil Pump and Motor, 60—222	1		
	960A0043H20	Pump, 2-LEVCC-A-5 (960A0043H53 Rebuilt)	1		
	960A0043H51	O-ring (Shaft Seal)	1		
	914A0057H01	Motor, 3/4 HP, 575-3-60	1		
	960A0043H11	Coupling, Drive	1		
	960A0043H06	Oil Pump and Motor, 60—222	1		
	960A0043H20	Pump, 2-LEVCC-A-5 (960A0043H53 Rebuilt)	1		
	960A0043H51	O-ring (Shaft Seal)	1		
	914A0057H03	Motor, 3/4 HP, 415-3-50	1		
	960A0043H11	Coupling, Drive	1		
	960A0043H07	Oil Pump and Motor, 60—222	1		
	960A0043H20	Pump, 2-LEVCC-A-5 (960A0043H53 Rebuilt)	1		
	960A0043H51	O-ring (Shaft Seal)	1		
	914A0057H04	Motor, 3/4 HP, 380-3-60	1		
	960A0043H11	Coupling, Drive	1		
	960A0066G02	Oil Pump and Motor, 270—399 & 480	1		
	960A0066H01	Pump, HJ495M	1		
	960A0066H41	Kit, Shaft Seal (incl. bearings, seal, o-ring & nut)	1		
	914A0015H02	Motor, 1-1/2 HP, 230/460-3-60	1		
	535M0197G01	Kit, Relief Valve (incl. hardware, gaskets or o-rings)	1		
	960A0066H11	Coupling, Drive	1		
	960A0066G04	Oil Pump and Motor, 496 & 676	1		
	960A0066H02	Pump, HL495M	1		
	960A0066H41	Kit, Shaft Seal (incl. bearings, seal, o-ring & nut)	1		
	914A0015H03	Motor, 3 HP, (230/460-3-60)(190/380-3-50)	1		
	535M0197G02	Kit, Relief Valve (incl. hardware, gaskets or o-rings)	1		
	960A0066H12	Coupling, Drive	1		

FIG. & INDEX	ITEM NUMBER	DESCRIPTION	QTY.	REV.	P & I REF.
	960A0066G06	Oil Pump and Motor, 100—676	1		
	960A0066H01	Pump, HJ495M	1		
	960A0066H41	Kit, Shaft Seal (incl. bearings, seal, o-ring & nut)	1		
	914A0015H04	Motor, 1-1/2 HP, 190/380-3-50	1		
	535M0197G01	Kit, Relief Valve (incl. hardware, gaskets or o-rings)	1		
	960A0066H11	Coupling, Drive	1		
	960A0066G09	Oil Pump and Motor, 270—399	1		
	960A0066H01	Pump, HJ495M	1		
	960A0066H41	Kit, Shaft Seal (incl. bearings, seal, o-ring & nut)	1		
	914A0015H08	Motor, 1-1/2 HP, 575-3-60	1		
	960A0066H11	Coupling, Drive	1		
	960A0066G10	Oil Pump and Motor, 270—399	1		
	960A0066H01	Pump, HJ495M	1		
	960A0066H41	Kit, Shaft Seal (incl. bearings, seal, o-ring & nut)	1		
	914A0015H07	Motor, 1-1/2 HP, 415-3-50	1		
	535M0197G01	Kit, Relief Valve (incl. hardware, gaskets or o-rings)	1		
	960A0066H11	Coupling, Drive	1		
	960A0066G13	Oil Pump and Motor, 496 & 676	1		
	960A0066H02	Pump, HL495M	1		
	960A0066H41	Kit, Shaft Seal (incl. bearings, seal, o-ring & nut)	1		
	914A0015H09	Motor, 3 HP, 415-3-50	1		
	960A0066H12	Coupling, Drive	1		
	960A0066G14	Oil Pump and Motor, 496 & 676	1		
	960A0066H02	Pump, HL495M	1		
	960A0066H41	Kit, Shaft Seal (incl. bearings, seal, o-ring & nut)	1		
	914A0015H10	Motor, 3 HP, 575-3-60	1		
	535M0197G02	Kit, Relief Valve (incl. hardware, gaskets or o-rings)	1		
	960A0066H12	Coupling, Drive	1		
	960A0066G16	Oil Pump and Motor, 270—399	1		
	960A0066H01	Pump, HJ495M	1		
	960A0066H41	Kit, Shaft Seal (incl. bearings, seal, o-ring & nut)	1		
	914A0015H11	Motor, 1-1/2 HP, 380-3-60	1		
	535M0197G01	Kit, Relief Valve (incl. hardware, gaskets or o-rings)	1		
	960A0066H11	Coupling, Drive	1		
	960A0066G18	Oil Pump and Motor, 496 & 676	1		
	960A0066H02	Pump, HL495M	1		
	960A0066H41	Kit, Shaft Seal (incl. bearings, seal, o-ring & nut)	1		
	914A0015H12	Motor, 3 HP, 380-3-60	1		
	535M0197G02	Kit, Relief Valve (incl. hardware, gaskets or o-rings)	1		
	960A0066H12	Coupling, Drive	1		
	960A0066G20	Oil Pump and Motor, 270—399 & 480	1		
	960A0066H01	Pump, HJ495M	1		
	960A0066H41	Kit, Shaft Seal (incl. bearings, seal, o-ring & nut)	1		
	914A0015H13	Motor, 2 HP, 230/460-3-60	1		
	535M0197G01	Kit, Relief Valve (incl. hardware, gaskets or o-rings)	1		
	960A0066H11	Coupling, Drive	1		
—8	944A0360G11	Flange, SW, 1-1/2", 270, 316, 399, 496	1		
	959A0057H05	Gasket, Flange, 1-1/2"	1		



FIG. & INDEX	ITEM NUMBER	DESCRIPTION	QTY.	REV.	P & I REF.
10—	535C0313	Thermosyphon Oil Cooler Piping, 60 & 76	Ref.	F	
	535C0317	Thermosyphon Oil Cooler Piping, 177 & 222	Ref.	F	
	535C0319	Thermosyphon Oil Cooler Piping, 316 & 399	Ref.	F	
	535C0268	Thermosyphon Oil Cooler Piping, 496 & 676	Ref.	D	
	535C0314	Water Cooled Oil Cooler Piping, 60 & 76	Ref.	F	
	535C0318	Water Cooled Oil Cooler Piping, 177 & 222	Ref.	F	
	535C0320	Water Cooled Oil Cooler Piping, 316 & 399	Ref.	F	
	535C0271	Water Cooled Oil Cooler Piping, 496 & 676	Ref.	C	
	720D0062	5 Ft. Water Cooled Oil Cooler Piping, 100 & 134	Ref.	—	
	720D0075	5 Ft. Water Cooled Oil Cooler Piping, 270	Ref.	—	
	720D0063	5 Ft. Water Cooled Oil Cooler Piping with Amot, 100 & 134	Ref.	—	
	720D0076	5 Ft. Water Cooled Oil Cooler Piping with Amot, 270	Ref.	—	
	720D0064	10 Ft. Water Cooled Oil Cooler Piping, 100 & 134	Ref.	—	
	720D0077	10 Ft. Water Cooled Oil Cooler Piping, 270	Ref.	—	
	720D0065	10 Ft. Water Cooled Oil Cooler Piping with Amot, 100 & 134	Ref.	—	
	720D0078	10 Ft. Water Cooled Oil Cooler Piping with Amot, 270	Ref.	—	
	720D0066	5 Ft. Thermosyphon Oil Cooler Piping, 100 & 134	Ref.	—	
	720D0079	5 Ft. Thermosyphon Oil Cooler Piping, 270	Ref.	—	
	720D0067	5 Ft. Thermosyphon Oil Cooler Piping with Amot, 100 & 134	Ref.	—	
	720D0080	5 Ft. Thermosyphon Oil Cooler Piping with Amot, 270	Ref.	—	
	720D0068	10 Ft. Thermosyphon Oil Cooler Piping, 100 & 134	Ref.	—	
	720D0081	10 Ft. Thermosyphon Oil Cooler Piping, 270	Ref.	—	
	720D0069	10 Ft. Thermosyphon Oil Cooler Piping with Amot, 100 & 134	Ref.	—	
	720D0082	10 Ft. Thermosyphon Oil Cooler Piping with Amot, 270	Ref.	—	
	720D0239	5 Ft. Water Cooled Oil Cooler Piping, 480	Ref.	—	
	720D0240	5 Ft. Water Cooled Oil Cooler Piping with Amot, 480	Ref.	—	
	720D0241	10 Ft. Water Cooled Oil Cooler Piping, 480	Ref.	—	
	720D0242	10 Ft. Thermosyphon Oil Cooler Piping with Amot, 270	Ref.	—	
	720D0243	5 Ft. Thermosyphon Oil Cooler Piping, 480	Ref.	—	
	720D0244	5 Ft. Thermosyphon Oil Cooler Piping with Amot, 480	Ref.	—	
	720D0245	10 Ft. Thermosyphon Oil Cooler Piping, 480	Ref.	—	
	720D0246	10 Ft. Thermosyphon Oil Cooler Piping with Amot, 480	Ref.	—	
	—1	952A0019H10	Valve, Safety, 1/2" Shank 803TJ, 300 PSIG, to Atmosphere*	1	
952A0025H01		Optional Arrangement with 400 PSIG Oil Coolers: Valve, Oil Safety Relief, 1/2" Shank, Vent to Separator *When replacing Frick ST Safety Valves contact factory for correct size.	1		
—2	950A0027H01	Valve, Water Temp. Reg. 1", WCOC only**	1		
	950A0027H02	Valve, Water Temp. Reg. 1-1/4", WCOC only**	1		
	950A0027H03	Valve, Water Temp. Reg. 1-1/2", WCOC only**	1		
	950A0027H04	Valve, Water Temp. Reg. 2", WCOC only**	1		
	950A0027H05	Valve, Water Temp. Reg. 2-1/2", WCOC only**	1		
	950A0027H06	Valve, Water Temp. Reg. 3", WCOC only** **Shipped loose. Customer installs in water outlet.	1		
—3	535A0154G01	Chamber, Bulbwell, Original	1		
	535A0391G01	Chamber, Bulbwell, Current	1		
—4	950A0233H05	Valve, Angle, SW, SC, 1-1/2"	1		
	950A0233H06	Valve, Angle, SW, SC, 2"	1		
	950A0241H07	Valve, Angle, SW, SC, 2-1/2"	1		
—5	580D0165G11	Valve, Angle, SW, SC, 1/2" (Frick)	1		
	950A0117H02	Valve, Angle, SW, SC, 1/2" (Herl)	1		

RWB II ROTARY SCREW COMPRESSOR UNIT  
SERVICE PARTS LIST



FIG. & INDEX	ITEM NUMBER	DESCRIPTION	QTY.	REV.	P & I REF.
10—	—	Oil Cooler Piping, Continued	Ref.		
—6	547D0079G01	Oil Cooler, Thermosyphon, 8-5/8 x 48", 300 PSIG, 2 Pass	1		
	547D0079G02	Oil Cooler, Thermosyphon, 8-5/8 x 72", 300 PSIG, 2 Pass	1		
	547D0079G03	Oil Cooler, Thermosyphon, 10-3/4 x 72", 300 PSIG, 2 Pass	1		
	547D0079G04	Oil Cooler, Thermosyphon, 10-3/4 x 96", 300 PSIG, 2 Pass	1		
	547D0079G05	Oil Cooler, Thermosyphon, 10-3/4 x 120", 300 PSIG, 2 Pass	1		
	547D0620G08	Oil Cooler, Thermosyphon, 12-3/4 x 96", 300 PSIG, 2 Pass	1		
	547D0620G09	Oil Cooler, Thermosyphon, 12-3/4 x 120", 300 PSIG, 2 Pass	1		
	547D0620G10	Oil Cooler, Thermosyphon, 12-3/4 x 144", 300 PSIG, 2 Pass	1		
	547D0620G11	Oil Cooler, Thermosyphon, 12-3/4 x 168", 300 PSIG, 2 Pass	1		
	547D0079G09	Oil Cooler, Thermosyphon, 16 x 120", 300 PSIG, 2 Pass	1		
	547D0079G10	Oil Cooler, Thermosyphon, 16 x 144", 300 PSIG, 2 Pass	1		
	547D0172G01	Oil Cooler, Thermosyphon, 24 x 120", 300 PSIG, 2 Pass	1		
	547C0071G01	Oil Cooler, Water Cooled, 8-5/8 x 72", 300 PSIG, 8 Pass	1		
	547C0178G01	Oil Cooler, Water Cooled, 8-5/8 x 96", 300 PSIG, 8 Pass	1		
	959A0018H12	Gasket, Head, WCOC, 8-5/8"	2		
	959A0018H10	Gasket, Strip, WCOC	1		
	901A0097H11	Stud, Head, WCOC, 8-5/8"	24		
	902A0021H01	Nut, Head, WCOC	24		
	547C0011G01	Oil Cooler, Water Cooled, 10-3/4 x 72", 300 PSIG, 6 Pass	1		
	547C0010G01	Oil Cooler, Water Cooled, 10-3/4 x 96", 300 PSIG, 6 Pass	1		
	547C0008G01	Oil Cooler, Water Cooled, 10-3/4 x 120", 300 PSIG, 6 Pass	1		
	540C0608H01	Gasket, Front, WCOC, 10-3/4"	1		
	540C0608H02	Gasket, Rear, WCOC, 10-3/4"	1		
	901A0098H11	Stud, Head, WCOC	24		
	902A0021H03	Nut, Head, WCOC	24		
	547C0012G01	Oil Cooler, Water Cooled, 12-3/4 x 120", 300 PSIG, 6 Pass	1		
	540C0608H03	Gasket, Front, WCOC, 12-3/4"	1		
	540C0608H04	Gasket, Rear, WCOC, 12-3/4"	1		
	901A0098H14	Stud, Head, WCOC	24		
	902A0021H03	Nut, Head, WCOC	24		
	547C0013G01	Oil Cooler, Water Cooled, 16 x 120", 300 PSIG, 6 Pass	1		
	547C0188G01	Oil Cooler, Water Cooled, 16 x 144", 300 PSIG, 4 Pass	1		
	540C0608H05	Gasket, Front, WCOC, 16", 6 Pass	1		
	540C0608H11	Gasket, Front, WCOC, 16", 4 Pass	1		
	540C0608H06	Gasket, Rear, WCOC, 16", 6 Pass	1		
	540C0608H12	Gasket, Rear, WCOC, 16", 4 Pass	1		
	901A0098H14	Stud, Head, WCOC	32		
	902A0021H03	Nut, Head, WCOC	32		
	547D0211G01	Oil Cooler, Thermosyphon, 6-5/8 x 60", 300 PSIG, 1 Pass	1		
	547D0212G01	Oil Cooler, Thermosyphon, 8-5/8 x 60", 300 PSIG, 1 Pass	1		
	547D0213G01	Oil Cooler, Thermosyphon, 6-5/8 x 120", 300 PSIG, 1 Pass	1		
	547D0214G01	Oil Cooler, Thermosyphon, 8-5/8 x 120", 300 PSIG, 1 Pass	1		
	547D0215G01	Oil Cooler, Thermosyphon, 10-3/4 x 120", 300 PSIG, 1 Pass	1		
	547D0216G01	Oil Cooler, Thermosyphon, 12-3/4 x 120", 300 PSIG, 1 Pass	1		
	547D0268G01	Oil Cooler, Thermosyphon, 16 x 120", 300 PSIG, 1 Pass	1		
	547D0217G01	Oil Cooler, Water Cooled, 6-5/8 x 60", 300 PSIG, 2 Pass	1		
	547D0219G01	Oil Cooler, Water Cooled, 6-5/8 x 120", 300 PSIG, 2 Pass	1		
	959A0043H01	Gasket, Head, WCOC, 6-5/8"	2		
	901A0098H10	Stud, Head, WCOC, 6-5/8"	16		
	902A0021H03	Nut, Head, WCOC	32		

FIG. & INDEX	ITEM NUMBER	DESCRIPTION	QTY.	REV.	P & I REF.
10—6	547D0218G01	Oil Cooler, Water Cooled, 8-5/8 x 60", 300 PSIG, 2 Pass	1		
	547D0220G01	Oil Cooler, Water Cooled, 8-5/8 x 120", 300 PSIG, 2 Pass	1		
	959A0043H02	Gasket, Head, WCOC, 8-5/8"	2		
	901A0098H10	Stud, Head, WCOC, 8-5/8"	16		
	902A0021H03	Nut, Head, WCOC	32		
	547D0221G01	Oil Cooler, Water Cooled, 10-3/4 x 120", 300 PSIG, 2 Pass	1		
	959A0043H03	Gasket, Head, WCOC, 10-3/4"	2		
	901A0098H11	Stud, Head, WCOC, 10-3/4"	24		
	902A0021H03	Nut, Head, WCOC	48		
	547D0222G01	Oil Cooler, Water Cooled, 12-3/4 x 120", 300 PSIG, 2 Pass	1		
	959A0043H04	Gasket, Head, WCOC, 12-3/4"	2		
	901A0098H12	Stud, Head, WCOC, 12-3/4"	24		
	902A0021H03	Nut, Head, WCOC	48		
	547D0269G01	Oil Cooler, Water Cooled, 16 x 120", 300 PSIG, 2 Pass	1		
	959A0068H05	Gasket, Head, WCOC, 16"	2		
	901A0098H11	Stud, Head, Front, WCOC, 16"	16		
	901A0098H09	Stud, Head, Rear, WCOC, 16"	16		
	902A0021H03	Nut, Head, WCOC	32		
	547D0485G01	Oil Cooler, Thermosyphon, 6-5/8 x 60", 400 PSIG, 1 Pass	1		
	547D0486G01	Oil Cooler, Thermosyphon, 8-5/8 x 60", 400 PSIG, 1 Pass	1		
	547D0487G01	Oil Cooler, Thermosyphon, 10-3/4 x 60", 400 PSIG, 1 Pass	1		
	547D0488G01	Oil Cooler, Thermosyphon, 8-5/8 x 120", 400 PSIG, 1 Pass	1		
	547D0490G01	Oil Cooler, Thermosyphon, 10-3/4 x 120", 400 PSIG, 1 Pass	1		
	547D0491G01	Oil Cooler, Thermosyphon, 12-3/4 x 120", 400 PSIG, 1 Pass	1		
	547D0492G01	Oil Cooler, Thermosyphon, 16 x 120", 400 PSIG, 1 Pass	1		
	547D0493G01	Oil Cooler, Water Cooled, 6-5/8 x 60", 400 PSIG, 2 Pass	1		
	547D0500G01	Oil Cooler, Water Cooled, 6-5/8 x 60", 400 PSIG, 4 Pass	1		
	959A0040H16	Gasket, Head, WCOC, 6-5/8"	2		
	959A0040H50	Strip, Gasket (Front Only)	1		
	901A0098H16	Stud, Head, WCOC, 6-5/8"	16		
	902A0021H03	Nut, Head, WCOC	32		
	547D0494G01	Oil Cooler, Water Cooled, 8-5/8 x 60", 400 PSIG, 2 Pass	1		
	547D0501G01	Oil Cooler, Water Cooled, 8-5/8 x 60", 400 PSIG, 4 Pass	1		
	959A0040H15	Gasket, Head, WCOC, 8-5/8"	2		
	959A0040H50	Strip, Gasket (Front Only)	1		
	901A0098H19	Stud, Head, WCOC, 8-5/8", 2 Pass	16		
	901A0098H21	Stud, Head, WCOC, 8-5/8", 4 Pass	16		
	902A0021H03	Nut, Head, WCOC	32		
	547D0495G01	Oil Cooler, Water Cooled, 6-5/8 x 120", 400 PSIG, 2 Pass	1		
	547D0502G01	Oil Cooler, Water Cooled, 6-5/8 x 120", 400 PSIG, 4 Pass	1		
	959A0040H16	Gasket, Head, WCOC, 6-5/8"	2		
	959A0040H50	Strip, Gasket (Front Only)	1		
	901A0098H16	Stud, Head, WCOC, 6-5/8"	16		
	902A0021H03	Nut, Head, WCOC	32		
	547D0496G01	Oil Cooler, Water Cooled, 8-5/8 x 120", 400 PSIG, 2 Pass	1		
	547D0503G01	Oil Cooler, Water Cooled, 8-5/8 x 120", 400 PSIG, 4 Pass	1		
	959A0040H15	Gasket, Head, WCOC, 8-5/8"	2		
959A0040H50	Strip, Gasket (Front Only)	1			
901A0098H19	Stud, Head, WCOC, 8-5/8", 2 Pass	16			
901A0098H21	Stud, Head, WCOC, 8-5/8", 4 Pass	16			
902A0021H03	Nut, Head, WCOC	32			

RWB II ROTARY SCREW COMPRESSOR UNIT  
SERVICE PARTS LIST



FIG. & INDEX	ITEM NUMBER	DESCRIPTION	QTY.	REV.	P & I REF.
10—	—	Oil Cooler Piping, Continued			
—6	547D0497G01	Oil Cooler, Water Cooled, 10-3/4 x 120", 400 PSIG, 2 Pass	1		
	547D0504G01	Oil Cooler, Water Cooled, 10-3/4 x 60", 400 PSIG, 4 Pass	1		
	959A0040H17	Gasket, Head, WCOC, 10-3/4"	2		
	959A0040H50	Strip, Gasket (Front Only)	1		
	901A0098H21	Stud, Head, WCOC, 10-3/4 x 120", 2 Pass	16		
	901A0098H22	Stud, Head, WCOC, 10-3/4 x 60", 4 Pass	16		
	902A0021H03	Nut, Head, WCOC	32		
	547D0498G01	Oil Cooler, Water Cooled, 12-3/4 x 120", 400 PSIG, 2 Pass	1		
	959A0040H18	Gasket, Head, WCOC, 12-3/4"	2		
	959A0040H50	Strip, Gasket (Front Only)	1		
	901A0098H24	Stud, Head, WCOC, 12-3/4"	24		
	902A0021H03	Nut, Head, WCOC	48		
	547D0499G01	Oil Cooler, Water Cooled, 16 x 120", 400 PSIG, 2 Pass	1		
	959A0040H19	Gasket, Head, WCOC, 16"	2		
	959A0040H50	Strip, Gasket (Front Only)	1		
	901A0098H31	Stud, Head, WCOC, 16"	24		
	902A0021H03	Nut, Head, WCOC	48		
—7	944A0360G09	Flange, SW, 1"	1		
	959A0057H03	Gasket, Flange, 1"	1		
	944A0360G11	Flange, SW, 1-1/2"	1		
	959A0057H05	Gasket, Flange, 1-1/2"	1		
	944A0360G12	Flange, SW, 2"	1		
	959A0057H07	Gasket, Flange, 2"	1		
—8	950A0029H01	Valve, Temp. Reg. 1" FPT, Amot	1		
	950A0066G01	Kit, Service, 1"	1		
	950A0029H21	Element, Thermostatic, 120°	1		
	950A0029G31	Kit, Seal	1		
	950A0046H01	Valve, Temp. Reg. 1" S.W., Amot	1		
	950A0066G01	Kit, Service, 1"	1		
	950A0029H21	Element, Thermostatic, 120°	1		
	950A0029G31	Kit, Seal	1		
	950A0028H01	Valve, Temp. Reg. 1-1/2" FPT, Amot	1		
	950A0067G01	Kit, Service, 1-1/2"	1		
	950A0028H21	Element, Thermostatic, 120°	1		
	950A0028G31	Kit, Seal	1		
	950A0030H01	Valve, Temp. Reg. 2" FPT, Amot	1		
	950A0068G01	Kit, Service, 2"	1		
	950A0030H21	Element, Thermostatic, 120°	1		
	950A0030G31	Kit, Seal	1		
—9	959A0075H06	Strainer, 2", Flanged, Y-type, WCOC	1		
	950A0075H26	Screen, 2" Strainer	1		
	950A0075H46	Gasket, 2" Strainer	1		
	959A0054H06	Gasket, Flange, 2" Strainer	2		
	950A0075H08	Strainer, 3", Flanged, Y-type, WCOC	1		
	950A0075H28	Screen, 3" Strainer	1		
	950A0075H48	Gasket, 3" Strainer	1		
	959A0054H08	Gasket, Flange, 3" Strainer	2		
	950A0075H09	Strainer, 4", Flanged, Y-type, WCOC	1		
	950A0075H29	Screen, 4" Strainer	1		
	950A0075H49	Gasket, 4" Strainer	1		
	944A0126H10	Gasket, Flange, 4" Strainer	2		

This page left blank intentionally.

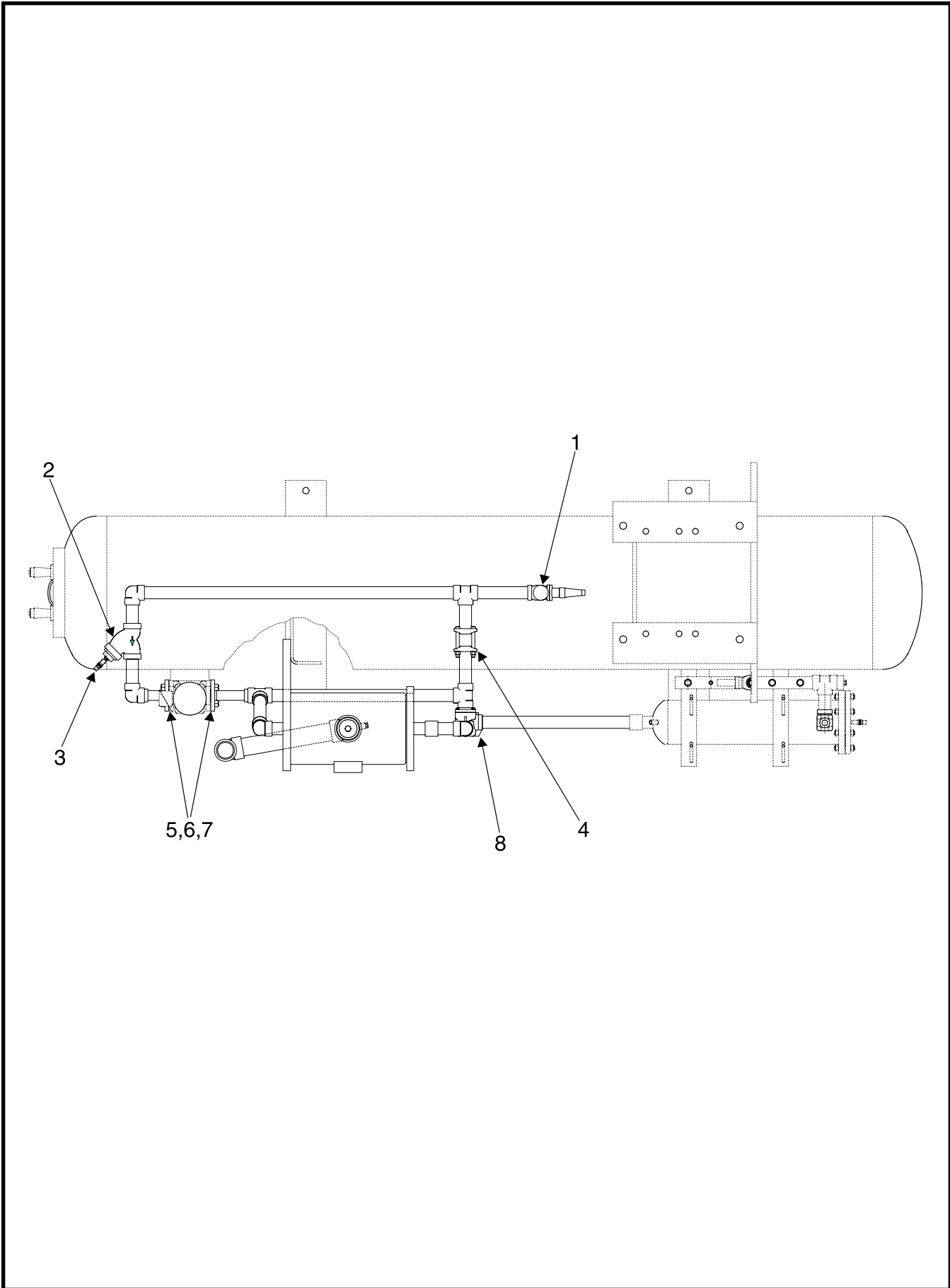

Figure 11. Oil Cooler Piping, WCOC and TSOC, Current.

FIG. & INDEX	ITEM NUMBER	DESCRIPTION	QTY.	REV.	P & I REF.	
11—	720D0374	Plate TSOC with Temperature Control Valve, 100 & 134	Ref.	—		
	720D0342	Plate TSOC with Temperature Control Valve, 177 & 222 (Shown)	Ref.	—		
	720D0355	Plate TSOC with Temperature Control Valve, 270	Ref.	—		
	720D0384	Plate TSOC with Temperature Control Valve, 316 & 399	Ref.	—		
	720D0372	Plate WCOC with Temperature Control Valve, 100 & 134	Ref.	—		
	720D0340	Plate WCOC with Temperature Control Valve, 177 & 222	Ref.	—		
	720D0353	Plate WCOC with Temperature Control Valve, 270	Ref.	—		
	720D0366	Plate WCOC with Temperature Control Valve, 316 & 399	Ref.	—		
—1	950A0233H06	Valve, Angle, SC, 2" SW	1			
	950A0241H07	Valve, Angle, SC, 2-1/2" BW	1			
—2	950A0069H07	Strainer, 1-1/2" SW, Y-type, TSOC	1			
	950A0069H25	Gasket, 1-1/2" Strainer	1			
	950A0069H37	Screen, 1-1/2" Strainer	1			
	950A0069H08	Strainer, 2" SW, Y-type, TSOC	1			
	950A0069H25	Gasket, 2" Strainer	1			
	950A0069H38	Screen, 2" Strainer	1			
	950A0001H07	Strainer, 2-1/2", SW Flanges, TSOC	1			
	950A0001H26	Screen Kit, 2-1/2" Strainer (includes spring & gasket)	1			
	950A0001H41	Gasket, Screen, 2-1/2" Strainer	1			
	950A0001H35	Gasket, Flange, 2-1/2" Strainer	2			
	—3	957A0003H01	Valve, Angle, SC, 1/4 MPT x 1/4 FPT	1		
	—4	956A0012G03	Valve, Check, 1-1/2" SW	1		
956A9912G01		Valve, Check, 2" SW	1			
956A0012G05		Valve, Check, 2-1/2" SW	1			
—5	944A0108H05	Flange, 1-1/2" 300PSI	2			
	944A0108H07	Flange, 2-1/2" 300PSI	2			
—6	959A0054H25	Gasket, 1-1/2" 300PSI	2			
	959A0054H27	Gasket, 2-1/2" 300PSI	2			
—7	901A0172H03	Flange Bolt Kit, 1-1/2"	2			
	901A0172H05	Flange Bolt Kit, 2-1/2"	2			
—8	950A0195H01	Valve, Temperature Control, 1-1/2" SW	1			
	950A0195H11	Kit, Thermostat & Gasket	1			
	950A0195H02	Valve, Temperature Control, 2" SW	1			
	950A0195H11	Kit, Thermostat & Gasket	1			
	950A0222H01	Valve, Temperature Control, 2-1/2" SW	1			
	950A0222H11	Kit, Thermostat & Gasket	1			

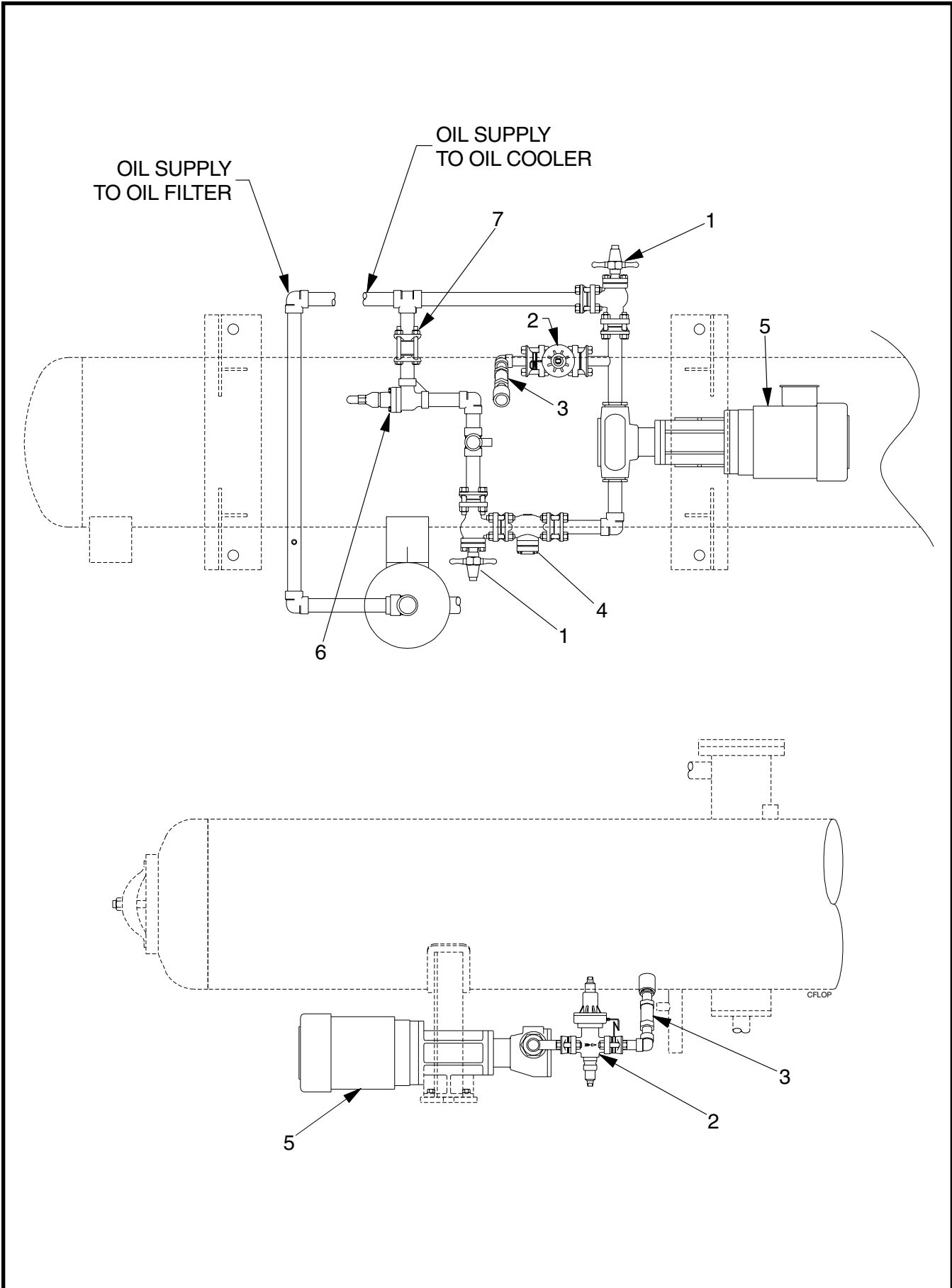

Figure 12. Full-Lube/Full-Cycling Oil Pump Piping, Typical.

FIG. & INDEX	ITEM NUMBER	DESCRIPTION	QTY.	REV.	P & I REF.
12—	720D0238	Cycling Full-Lube Oil Pump, 480	Ref.	A	
	720D0047	Full-Lube Oil Pump Piping, 60 & 76	Ref.	E	
	720D0228	Full-Lube Oil Pump Piping, 100 & 134	Ref.	B	
	720D0085	Full-Lube Oil Pump Piping, 177 & 222	Ref.	E	
	720D0073	Full-Lube Oil Pump Piping, 270	Ref.	G	
	720D0106	Full-Lube Oil Pump Piping, 316 & 399	Ref.	D	
	720D0237	Full-Lube Oil Pump Piping, 480	Ref.	A	
	720D0119	Oil Pump, 496 & 676	Ref.	C	
	720D0211	Full-Lube Oil Pump Piping, 856	Ref.	A	
	720D0048	Full-Cycling Oil Pump, 60 & 76	Ref.	E	
	720D0229	Full-Cycling Oil Pump, 100 & 134	Ref.	B	
	720D0086	Full-Cycling Oil Pump, 177 & 222	Ref.		
	720D0074	Full-Cycling Oil Pump, 270	Ref.	E	
	720D0107	Full-Cycling Oil Pump, 316 & 399	Ref.	D	
	720M0004G32	Full-Cycling Oil Pump, 480, 60Hz	Ref.		
	720M0004G31	Full-Cycling Oil Pump, 480, 50Hz	Ref.		
	720D0127	Full-Cycling Oil Pump, 676	Ref.	C	
—1	950A0085G02	Valve, Angle, Seal Cap, 1-1/2" Flg., 60—134	2		
	580D0019G02	Valve, Angle, Seal Cap, 2" Flg., 177—222	2		
	950A0089H02	Valve, Angle, Seal Cap, 2-1/2" Flg., 270—399	2		
	950A0137G02	Valve, Angle, Seal Cap, 3" BW, 856	2		
—2	954A0007H01	Regulator, Differential Pressure, 1", 60—399	1		
	954A0007H06	Flange Ring & Tube Assembly, 1"	1		
	959A0057H03	Gasket, Flange, 1"	2		
	954A0007H03	Regulator, Differential Pressure, 1-1/4", 496—856	1		
	954A0007H07	Flange Ring & Tube Assembly, 1-1/4"	1		
959A0057H04	Gasket, Flange, 1-1/4"	2			
—3	956A0014H02	Valve, Check, In-Line, 1", 60—399	1		
	956A0014H01	Valve, Check, In-Line, 1-1/4", 60—399	1		
	956A0012G06	Valve, Check, In-Line, 1-1/4", 496—856	1		
—4	950A0069H07	Strainer, 60 Mesh, 1-1/2", Current, (Hayward), 60—76	1		
	950A0069H25	Gasket, Screen	1		
	950A0069H37	Screen only	1		
	951A0037H16	Strainer, 40 Mesh, 1-1/2", (Hubbel), 60—134	1		
	951A0037H26	Screen only	1		
	951A0037H36	Gasket, Screen	1		
	951A0037H14	Strainer, 40 Mesh, 2", (Hubbel), 177 & 222	1		
	951A0037H24	Screen only	1		
	951A0037H34	Gasket, Screen	1		
	951A0037H15	Strainer, 40 Mesh, 2-1/2", Original, (Hubbel), 270—399	1		
	951A0037H25	Screen only	1		
	951A0037H35	Gasket, Screen	1		
	950A0001H07	Strainer, 60 Mesh, 2-1/2", Current, (R/S), 270—399	1		
	950A0001H26	Kit, Screen (includes gasket & spring)	1		
	950A0001H35	Gasket, Flange	2		
	950A0001H09	Strainer, 60 Mesh, 3", Current, (R/S), 496—856	1		
950A0001H28	Kit, Screen (includes screen, spring & gasket)	1			
950A0001H36	Gasket, Flange	2			
—5	960A0066G01	Oil Pump/Motor, Viking, 1.5 HP, 1750 RPM	1		
	960A0066H01	Pump, HJ495M	1		P-1
	960A0066H51	Pump, Rebuilt, HJ495M	1		P-1
	960A0066H41	Kit, Shaft Seal (incl. bearings, seal, o-ring & nut)	1		
	914A0015H02	Motor only, 230/460V	1		PM-1
	960A0066H11	Coupling, Drive	1		

**RWB II ROTARY SCREW COMPRESSOR UNIT  
SERVICE PARTS LIST**



FIG. & INDEX	ITEM NUMBER	DESCRIPTION	QTY.	REV.	P & I REF.
12—	—	Full Lube/Full Cycling Oil Pump Piping, Continued			
—5	960A0066G05	Oil Pump/Motor, Viking, 1.5 HP, 1450 RPM	1		
	960A0066H01	Pump, HJ495M	1		P-1
	960A0066H51	Pump, Rebuilt, HJ495M	1		P-1
	960A0066H41	Kit, Shaft Seal (incl. bearings, seal, o-ring & nut)	1		
	914A0015H02	Motor only, 190/380V	1		PM-1
	960A0066H11	Coupling, Drive	1		
	960A0066G03	Oil Pump/Motor, Viking, 3 HP, 1450/1750 RPM	1		
	960A0066H02	Pump, HL495M	1		P-1
	960A0066H52	Pump, Rebuilt, HL495M	1		P-1
	960A0066H41	Kit, Shaft Seal (incl. bearings, seal, o-ring & nut)	1		
	914A0015H03	Motor only, 190/380V-230/460V	1		PM-1
	960A0066H12	Coupling, Drive	1		
	960A0066G19	Oil Pump/Motor, Viking, 2 HP, 1750 RPM	1		
	960A0066H01	Pump, HJ495M	1		P-1
	960A0066H41	Kit, Shaft Seal (incl. bearings, seal, o-ring & nut)	1		
	914A0015H13	Motor only, 230/460V	1		PM-1
	960A0066H11	Coupling, Drive	1		
	960A0066G21	Oil Pump/Motor, Viking, 2 HP, 1450 RPM	1		
	960A0066H01	Pump, HJ495M	1		P-1
	960A0066H41	Kit, Shaft Seal (incl. bearings, seal, o-ring & nut)	1		
	914A0015H15	Motor only, 190/380V	1		PM-1
	960A0066H11	Coupling, Drive	1		
	960A0067G01	Oil Pump/Motor, Viking, 3 HP, 1150 RPM	1		
	960A0067H01	Pump, AS495M	1		P-1
	960A0067H41	Kit, Shaft Seal (incl. bearings, seals, o-ring & nut)	1		
	914A0016H01	Motor only, 230/460V	1		PM-1
	960A0067H11	Coupling, Drive	1		
	960A0067G03	Oil Pump/Motor, Viking, 5 HP, 1450 RPM	1		
	960A0067H01	Pump, AS495M	1		P-1
	960A0067H41	Kit, Shaft Seal (incl. bearings, seals, o-ring & nut)	1		
	914A0016H02	Motor only, 190/380V	1		PM-1
	960A0067H11	Coupling, Drive	1		
	960A0067G05	Oil Pump/Motor, Viking, 5 HP, 1150 RPM	1		
	960A0067H02	Pump, AK495M	1		P-1
	960A0067H41	Kit, Shaft Seal (incl. bearings, seals, o-ring & nut)	1		
	914A0016H03	Motor 230/460V	1		PM-1
	960A0067H11	Coupling, Drive	1		
	960A0067G09	Oil Pump/Motor, Viking, 7.5 HP, 1150 RPM	1		
	960A0067H03	Pump, AL495M	1		P-1
	960A0067H41	Kit, Shaft Seal (incl. bearings, seals, o-ring & nut)	1		
	914A0016H05	Motor 230/460V	1		PM-1
	960A0067H12	Coupling, Drive	1		
	960A0067G07	Oil Pump/Motor, Viking, 7.5 HP, 1450 RPM	1		
	960A0067H02	Pump, AK495M	1		P-1
	960A0067H41	Kit, Shaft Seal (incl. bearings, seals, o-ring & nut)	1		
	914A0016H04	Motor 190/380V	1		PM-1
	960A0067H11	Coupling, Drive	1		
	960A0060H01	Oil Pump/Motor, Viking w/gear reducer, 7.5 HP (Original)	1		
	960A0060H11	Pump, L4125	1		P-1
	960A0060H41	Kit, Shaft Seal (incl. bearing, seals, & gaskets)	1		
	914A0016H06	Motor 230/460V	1		PM-1
	960A0060H20	Gear Reducer, 4.1 Ratio	1		
	960A0060H30	Coupling	1		

FIG. & INDEX	ITEM NUMBER	DESCRIPTION	QTY.	REV.	P & I REF.
	960A0080G01	Oil Pump/Motor, Viking w/gear reducer, 7.5 HP (Current)	1		
	960A0080H01	Pump, L4124A	1		P-1
	960A0078H41	Kit, Shaft Seal (incl. bearing, seals, & gaskets)	1		
	914A0016H06	Motor 230/460V	1		PM-1
	960A0080H20	Gear Reducer, 4.1 Ratio	1		
	960A0080H30	Coupling	1		
	960A0080G07	Oil Pump/Motor, Viking w/gear reducer, 7.5 HP (Current)	1		
	960A0080H01	Pump, L4124A	1		P-1
	960A0078H41	Kit, Shaft Seal (incl. bearing, seals, & gaskets)	1		
	914A0016H10	Motor 190/380V	1		PM-1
	960A0080H20	Gear Reducer, 4.1 Ratio	1		
	960A0080H30	Coupling	1		
	960A0060H02	Oil Pump/Motor, Viking w/gear reducer, 10 HP (Original)	1		
	960A0060H11	Pump, L4125	1		P-1
	960A0060H41	Kit, Shaft Seal (incl. bearing, seals, & gaskets)	1		
	914A0016H07	Motor 230/460V	1		PM-1
	960A0060H21	Gear Reducer	1		
	960A0060H31	Coupling	1		
	960A0080G02	Oil Pump/Motor, Viking w/gear reducer, 10 HP (Current)	1		
	960A0080H01	Pump, L4124A	1		P-1
	960A0078H41	Kit, Shaft Seal (incl. bearing, seals, & gaskets)	1		
	914A0016H07	Motor 230/460V	1		PM-1
	960A0080H22	Gear Reducer	1		
	960A0080H31	Coupling	1		
	960A0078G03	Oil Pump/Motor, Viking w/gear reducer, 10 HP	1		
	960A0078H01	Pump, LQ4124A	1		P-1
	960A0078H41	Kit, Shaft Seal (incl. bearing, seals, & gaskets)	1		
	914A0016H07	Motor 230/460	1		PM-1
	960A0078H21	Gear Reducer	1		
	960A0078H32	Coupling	1		
	960A0078G09	Oil Pump/Motor, Viking w/gear reducer, 10 HP	1		
	960A0078H01	Pump, LQ4124A	1		P-1
	960A0078H41	Kit, Shaft Seal (incl. bearing, seals, & gaskets)	1		
	914A0016H11	Motor 190/380	1		PM-1
	960A0078H21	Gear Reducer	1		
	960A0078H32	Coupling	1		
	960A0080G08	Oil Pump/Motor, Viking w/gear reducer, 10 HP (Current)	1		
	960A0080H01	Pump, L4124A	1		P-1
	960A0078H41	Kit, Shaft Seal (incl. bearing, seals, & gaskets)	1		
	914A0016H11	Motor 190/380V	1		PM-1
	960A0080H22	Gear Reducer, 3.3 Ratio	1		
	960A0080H31	Coupling	1		
—6	950A0241H05	Valve, Angle, Seal Cap, 1-1/2" W.I.L., 60 & 76	1		
	950A0233H05	Valve, Angle, Seal Cap, 1-1/2" S.W., 100 & 134	1		
	950A0233H06	Valve, Angle, Seal Cap, 2" S.W., 177—270	1		
	950A0241H07	Valve, Angle, Seal Cap, 2-1/2" W.I.L., (Gram), 316 & 399	1		
—7	956A0012G06	Valve, Check, 1-1/4" S.W.	1		
	956A0012G03	Valve, Check, 1-1/2" S.W.	1		
	956A9912G01	Valve, Check, 2" S.W.	1		
	956A0012G05	Valve, Check, 2-1/2" S.W.	1		

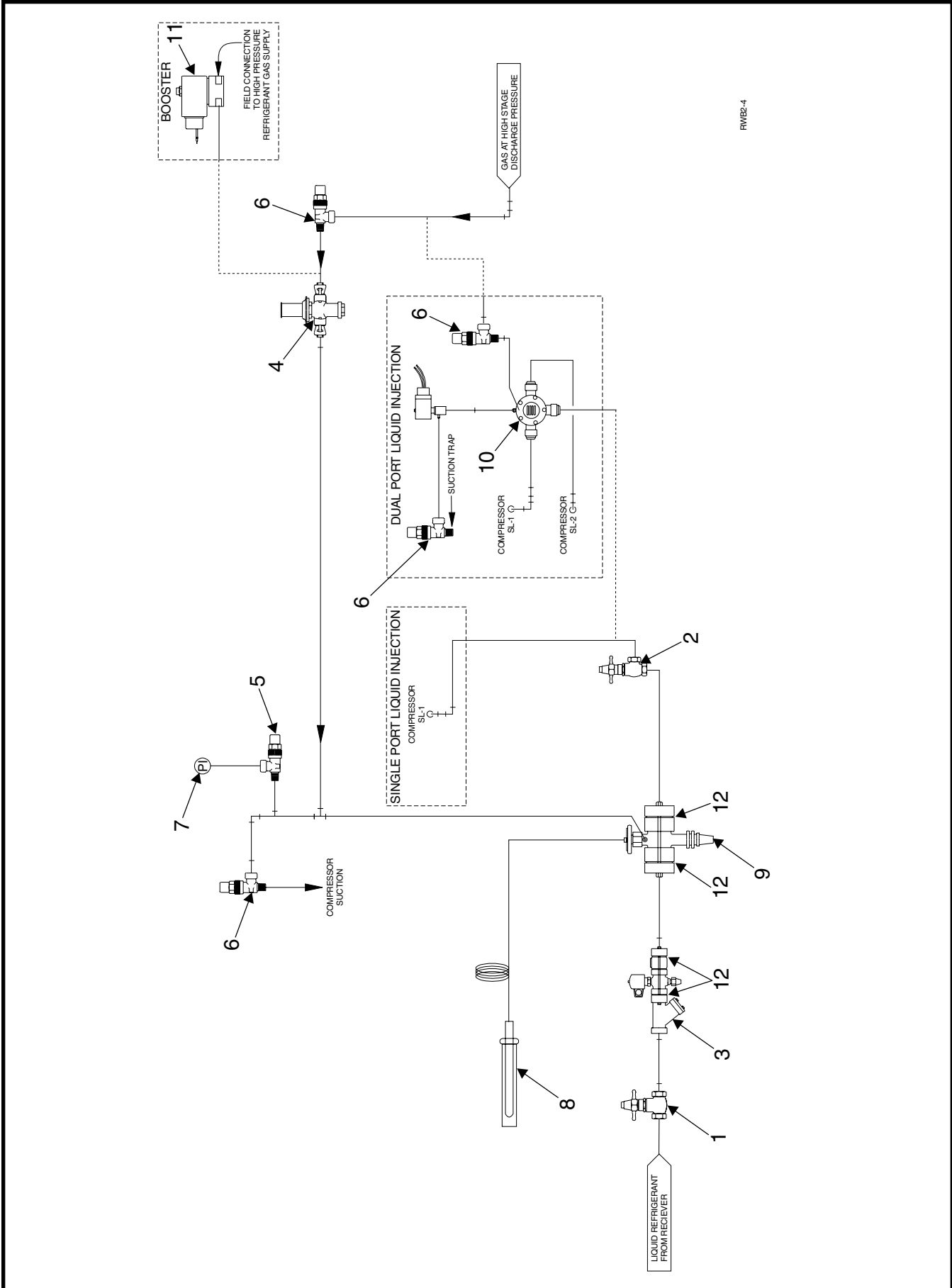

Figure 13. Liquid Injection Piping, Typical.

FIG. & INDEX	ITEM NUMBER	DESCRIPTION	QTY.	REV.	P & I REF.
13—	720C0012	Single-Port Liquid Injection	Ref.	C	
	720C0013	Dual-Port Liquid Injection	Ref.	C	
	720C0014	Liquid Injection - Booster	Ref.	D	
	720C0022	Single-Port Liquid Injection	Ref.	—	
	720C0023	Dual-Port Liquid Injection	Ref.	—	
	720C0024	Liquid Injection - Booster	Ref.	—	
—1	950A0249H01	Valve, Globe, Seal Cap, 1/2" NPT	1		
	950A0245H01	Valve, Globe, Seal Cap, 1/2" SW	1		
	950A0249H02	Valve, Globe, Seal Cap, 3/4" NPT	1		
	950A0245H02	Valve, Globe, Seal Cap, 3/4" SW	1		
	950A0249H03	Valve, Globe, Seal Cap, 1" NPT	1		
	950A0245H03	Valve, Globe, Seal Cap, 1" SW	1		
	950A0245H04	Valve, Globe, Seal Cap, 1-1/4" SW	1		
	950A0249H04	Valve, Globe, Seal Cap, 1-1/4" NPT	1		
	950A0245H05	Valve, Globe, Seal Cap, 1-1/2" SW	1		
—2	950A0237H01	Valve, Angle, Seal Cap, 1/2" NPT	1		
	950A0233H01	Valve, Angle, Seal Cap, 1/2" SW	1		
	950A0237H02	Valve, Angle, Seal Cap, 3/4" NPT	1		
	950A0233H02	Valve, Angle, Seal Cap, 3/4" SW	1		
	950A0237H03	Valve, Angle, Seal Cap, 1" NPT	1		
	950A0233H03	Valve, Angle, Seal Cap, 1" SW	1		
	950A0233H04	Valve, Angle, Seal Cap, 1-1/4" SW	1		
—3	950A0018G01	Kit, Valve & Strainer, 3/4" NPT, w/AAE 20—100, R-717 <sup>(1)</sup>	Ref.		
	951A0041H01	Valve, Solenoid, 3/4" FPT	1		SV5
	950A0190H01	Coil, Solenoid, 120V/60Hz	1		
	950A0012H01	Strainer, 80 Mesh, 3/4" FPT	1		
	950A0012H04	Screen w/Gasket	1		
	950A0018G02	Kit, Valve & Strainer, 1/2" NPT, w/DAE 2 & 5, R-717 <sup>(1)</sup>	Ref.		
	951A0066H01	Valve, Solenoid	1		SV5
	950A0190H01	Coil, Solenoid, 120V/60Hz	1		
	950A0019H01	Strainer, 100 Mesh, 1/2" FPT/flanged outlet	1		
	950A0019H04	Kit, Strainer Screen & Gasket	1		
	950A0042G01	Kit, Valve & Strainer, 1/2" NPT, w/DAE 10 & 15, R-717 <sup>(1)</sup>	Ref.		
	951A0041H01	Valve, Solenoid, 3/4" FPT	1		SV-5
	950A0190H01	Coil, Solenoid, 120V/60Hz	1		
	950A0054H01	Strainer, 80 Mesh, 1/2" FPT	1		
	950A0054H04	Kit, Strainer Screen & Gasket	1		
	950A0186G01	Kit, Valve & Regulator, 3/4" SW, w/AAE 20—100, R-717 <sup>(1)</sup>	Ref.		
	951A0041H01	Valve, Solenoid, 3/4" FPT	1		SV-5
	950A0190H01	Coil, Solenoid, 120V/60Hz	1		
	950A0069H04	Strainer, 60 Mesh, Y-type, 3/4" SW (not incl. w/950A0186G01)	1		
	950A0069H22	Gasket, Strainer	1		
	950A0069H34	Screen, Strainer	1		
	950A0186G03	Kit, Valve & Regulator, 1" SW, w/AAE 20—100, R-717 <sup>(1)</sup>	Ref.		
	951A0041H01	Valve, Solenoid, 3/4" NPT	1		SV-5
	950A0190H01	Coil, Solenoid, 120V/60Hz	1		
	950A0069H05	Strainer, 60 Mesh, Y-type, 1" SW (not incl. w/950A0186G03)	1		
	950A0069H23	Gasket, Strainer	1		
	950A0069H35	Screen, Strainer	1		

RWB II ROTARY SCREW COMPRESSOR UNIT  
SERVICE PARTS LIST



FIG. & INDEX	ITEM NUMBER	DESCRIPTION	QTY.	REV.	P & I REF.
13—	—	Liquid Injection, Continued	Ref.		
—3	950A0186G02	Kit, Valve & Strainer, 1/2" SW, w/DAE 2 & 5, R-717 <sup>(1)</sup>	Ref.		
	951A0066H01	Valve, Solenoid	1		SV5
	950A0190H01	Coil, Solenoid, 120V/60Hz	1		
	950A0069H03	Strainer, 100 Mesh	1		
	950A0069H21	Gasket, Screen	1		
	950A0069H33	Screen only	1		
	950A0188G01	Kit, Valve & Regulator, 1/2" SW, w/DAE 10 & 15, R-717 <sup>(1)</sup>	Ref.		
	951A0041H01	Valve, Solenoid, 3/4" FPT	1		SV-5
	950A0190H01	Coil, Solenoid, 120V/60Hz	1		
	950A0069H03	Strainer, 60 Mesh, Y-type, 1/2" SW (not incl. w/950A0188G01)	1		
	950A0069H21	Gasket, Strainer	1		
	950A0069H33	Screen only	1		
	950A0021G03	Kit, Valve & Strainer, 1/2" NPT, w/HVE 2—16, R-22 <sup>(1)</sup>	Ref.		
	951A0041H01	Valve, Solenoid, 3/4" FPT	1		SV-5
	950A0190H01	Coil, Solenoid, 120V/60Hz	1		
	950A0012H01	Strainer, 80 Mesh, 3/4" FPT	1		
	950A0012H04	Screen w/Gasket	1		
	950A0021G04	Kit, Valve & Strainer, 1" NPT, w/MVE 12—34, R-22 <sup>(1)</sup>	Ref.		
	Contact Frick Parts	Valve, Solenoid, 1" FPT	1		SV-5
	950A0190H03	Coil, Solenoid, 120V/60Hz	1		
	950A0012H01	Strainer, 80 Mesh, 3/4" FPT	1		
	950A0012H04	Screen w/Gasket	1		
	950A0021G05	Kit, Valve & Regulator, 1-1/2" NPT, w/VVE 52—100, R-22 <sup>(1)</sup>	Ref.		
	951A0065H01	Valve, Solenoid, 1-1/2" FPT	1		SV-5
	950A0190H01	Coil, Solenoid, 120V/60Hz	1		
	951A0037H16	Strainer, 40 Mesh, 1-1/2" FPT (not incl. w/950A0021G05)	1		
	950A0187G01	Kit, Valve & Regulator, 1/2" SW, w/HVE 2-1/2—16, R-22 <sup>(1)</sup>	1		
	951A0041H01	Valve, Solenoid, 3/4" FPT	1		SV-5
	950A0190H01	Coil, Solenoid, 120V/60Hz	1		
	950A0069H04	Strainer, 60 Mesh, Y-type, 3/4" SW (not incl. w/950A0187G01)	1		
	950A0069H22	Gasket, Screen	1		
	950A0069H34	Screen only	1		
	950A0187G02	Kit, Valve & Regulator, 1" SW, w/MVE 12—34, R-22 <sup>(1)</sup>	1		
	Contact Frick Parts	Valve, Solenoid, 1" SW Flange	1		SV-5
	950A0190H03	Coil, Solenoid, 120V/60Hz	1		
	950A0069H05	Strainer, 60 Mesh, Y-type, 1" SW (not incl. w/950A0187G02)	1		
	950A0069H23	Gasket, Screen	1		
	950A0069H35	Screen only	1		
	950A0187G03	Kit, Valve & Regulator, 1-1/2" SW, w/VVE 52—100, R-22 <sup>(1)</sup>	1		
	951A0065H01	Valve, Solenoid, 1-1/2" FPT	1		SV-5
	950A0190H01	Coil, Solenoid, 120V/60Hz	1		
	950A0069H07	Strainer, 60 Mesh, Y-type, 1-1/2" SW (not incl. w/950A0187G03)	1		
	950A0069H25	Gasket, Strainer	1		
—4	954A0008H01	Regulator, Pressure	1		
	954A0008H02	Element, Replacement	1		
	954A0008H03	Gasket, Flange	2		
—5	957A0003H01	Valve, Angle, Seal Cap, 1/4", R-717, R-22	1		
—6	957A0003H02	Valve, Angle, Seal Cap, 3/8", R-717, R-22	4		
—7	990A0011H02	Gauge, Pressure, R-717, R-22	1		PI

FIG. & INDEX	ITEM NUMBER	DESCRIPTION	QTY.	REV.	P & I REF.
—8	531A0139H01	Well, Standard TX Valve	1		
—9	954A0050H01	Valve, Therm. Exp., R-717, DAE-1.0 lbs/min cap. <sup>(2)</sup>	1	A	TX
	954A0050H02	Valve, Therm. Exp., R-717, DAE-2.5 lbs/min cap. <sup>(2)</sup>	1	A	TX
	954A0050H03	Valve, Therm. Exp., R-717, DAE-5.0 lbs/min cap. <sup>(2)</sup>	1	A	TX
	954A0050H04	Valve, Therm. Exp., R-717, DAE-7.5 lbs/min cap. <sup>(2)</sup>	1	A	TX
	959A0089H03	Gasket, Flange, for DAE	2	—	
	954A0010H20	Element, Power, for DAE	1	A	
	954A0050H05	Valve, Therm. Exp., R-717, AAE-8.9 lbs/min cap. <sup>(2)</sup>	1	A	TX
	954A0050H06	Valve, Therm. Exp., R-717, AAE-13.3 lbs/min cap. <sup>(2)</sup>	1	A	TX
	954A0050H07	Valve, Therm. Exp., R-717, AAE-22.3 lbs/min cap. <sup>(2)</sup>	1	A	TX
	954A0050H08	Valve, Therm. Exp., R-717, AAE-33.4 lbs/min cap. <sup>(2)</sup>	1	A	TX
	954A0050H09	Valve, Therm. Exp., R-717, AAE-44.6 lbs/min cap. <sup>(2)</sup>	1	A	TX
	959A0089H02	Gasket, Flange, for AAE	2	—	
	954A0010H30	Element, Power, for AAE	1	C	
	954A0051H01	Valve, Therm. Exp., R-22, HVE-8.73 lbs/min cap. <sup>(2)</sup>	1	A	TX
	954A0051H02	Valve, Therm. Exp., R-22, HVE-19.5 lbs/min cap. <sup>(2)</sup>	1	A	TX
	954A0051H03	Valve, Therm. Exp., R-22, HVE-36.7 lbs/min cap. <sup>(2)</sup>	1	A	TX
	954A0051H04	Valve, Therm. Exp., R-22, HVE-53.1 lbs/min cap. <sup>(2)</sup>	1	A	TX
	959A0089H03	Gasket, Flange, for HVE	2	—	
	959A0089H04	Gasket, Adaptor Ring, for HVE	2	—	
	954A0012H20	Element, Power, for HVE	1	A	
	954A0051H06	Valve, Therm. Exp., R-22, MVE-81.3 lbs/min cap. <sup>(2)</sup>	1	A	TX
	954A0051H07	Valve, Therm. Exp., R-22, MVE-129.0 lbs/min cap. <sup>(2)</sup>	1	A	TX
	959A0089H02	Gasket, Flange, for MVE	2	—	
	954A0012H30	Element, Power, for MVE	1	A	
	954A0051H08	Valve, Therm. Exp., R-22, VVE-197.0 lbs/min cap. <sup>(2)</sup>	1	A	TX
	959A0089H02	Gasket, Flange, for VVE-52	2	—	
	954A0051H09	Valve, Therm. Exp., R-22, VVE-276.0 lbs/min cap. <sup>(2)</sup>	1	A	TX
	954A0051H10	Valve, Therm. Exp., R-22, VVE-378.0 lbs/min cap. <sup>(2)</sup>	1	A	TX
	959A0089H01	Gasket, Flange, for VVE 70 & 100	2	—	
	954A0012H30	Element, Power, for VVE	1	A	
—10	951A0053G01	Solenoid Valve, 3-Way, R-717, R-22 (Plus Fittings)	1		SV-7
	951A0053H01	Solenoid Valve, Less Coil (Plus Fittings)	1		
	951A0054H01	Coil, 120V	1		
	951A0053G11	Repair Kit consisting of:	1		
	951A0053G01	Assy., Valve, Solenoid, 3-Way	1		
	944A0117H01	Fitting, Connector, Female	2		
	951A0057G01	Solenoid Valve, 3-Way, R-22	1		SV-7
	951A0057H01	Solenoid Valve, Less Coil	1		
	951A0054H01	Coil, 120V	1		
—11	951A0020H01	Solenoid Valve, R-717, R-22	1		SV-10
	951A0020H11	Coil, Solenoid, 120V	1		
—12	959A0089H01	Gasket, Flange, VVE 70-100	2		
	959A0089H02	Gasket, Flange, AAE, MVE & VVE 52-60	2		
	959A0089H03	Gasket, Flange, DAE & HVE 2-20	2		
	959A0089H04	Gasket, Flange, HVE 2-20	2		

(1) Solenoid Valve and Strainer are determined by which TX Valve is used. For proper ordering of Liquid Injection components, refer to Thermal Expansion Valve nameplate for size and model designation. Note that Kit numbers are for identification purposes, and are not used for ordering. Early kits use NPT connections, while later kits use socket weld connections.

(2) Internal Replacement Parts Kits are available for the 954A0050 and 954A0051 TX Valve. Contact Baltimore Parts Center.

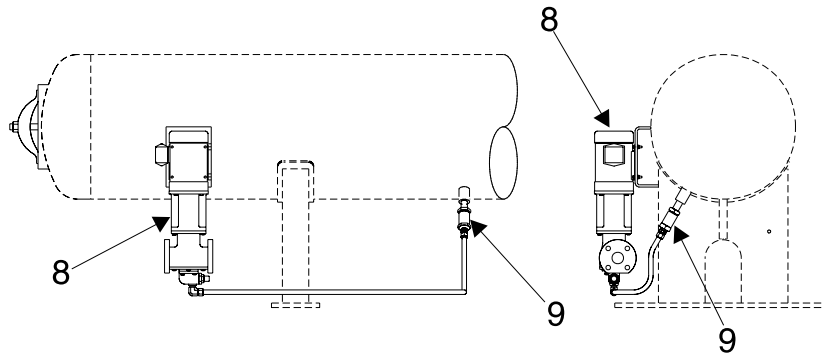

Figure 14a. Oil Pump Mounting and Tubing Assbly.

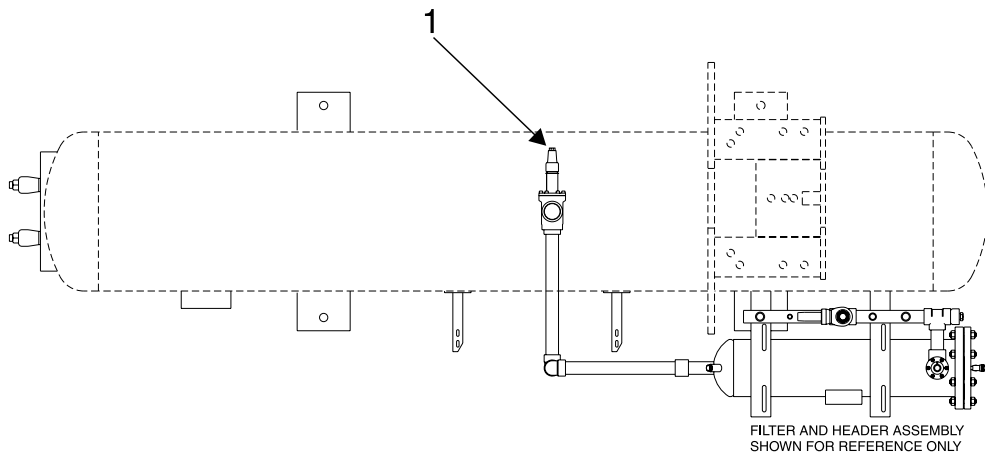

Figure 14b. Liquid Injection Piping.

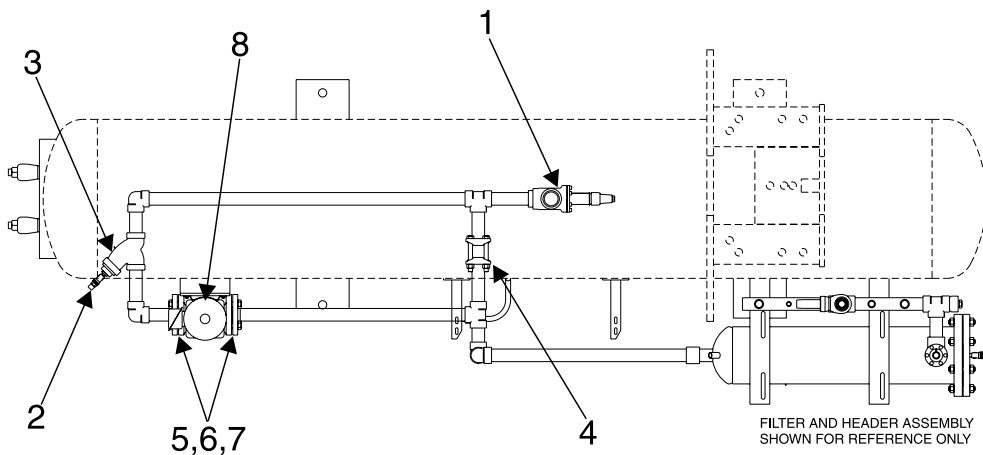

Figure 14c. Liquid Injection with Oil Pump.

Figure 14. Liquid Injection with Oil Pump, Current.

FIG. & INDEX	ITEM NUMBER	DESCRIPTION	QTY.	REV.	P & I REF.
14—	720D0377	Oil Pump Mounting and Tubing Assbly., 100 & 134	Ref.	—	
	720D0345	Oil Pump Mounting and Tubing Assbly., 177 & 222	Ref.	—	
	720D0358	Oil Pump Mounting and Tubing Assbly., 270	Ref.	—	
	720D0385	Oil Pump Mounting and Tubing Assbly., 316 & 399	Ref.	—	
	720D0378	Liquid Injection Piping, 100 & 134	Ref.	—	
	720D0346	Liquid Injection Piping, 177 & 222	Ref.	—	
	720D0359	Liquid Injection Piping, 270, 316 & 399	Ref.	—	
	720D0379	Liquid Injection with Oil Pump, 100 & 134	Ref.	—	
	720D0347	Liquid Injection with Oil Pump, 177 & 222	Ref.	—	
	720D0360	Liquid Injection with Oil Pump, 270	Ref.	—	
	720D0386	Liquid Injection with Oil Pump, 316 & 399	Ref.	—	
—1	82407549909	Valve, Angle, SC, 2" SW, Gram	1		
	950A0233H06	Valve, Angle, SC, 2" SW, Danfoss	1		
	82408536209	Valve, Angle, SC, 2-1/2" BW, Gram	1		
	950A0241H07	Valve, Angle, SC, 2-1/2" BW, Danfoss	1		
—2	957A0003H01	Valve, Angle, SC, 1/4" FPT	1		
—3	950A0069H07	Strainer, Y-type, 1-1/2" SW	1		
	950A0069H25	Gasket, Strainer	1		
	950A0069H37	Screen, Strainer	1		
	950A0069H08	Strainer, Y-type, 2" SW	1		
	950A0069H25	Gasket, Strainer	1		
	950A0069H38	Screen, Strainer	1		
	950A0001H07	Strainer, 2-1/2" SW	1		
	950A0001H35	Gasket, Flange	2		
	950A0001H26	Kit, Screen & Spring w/Gasket	1		
	950A0001H41	Gasket only	1		
—4	956A0012G03	Valve, Check, 1-1/2" SW	1		
	956A0012G05	Valve, Check, 2-1/2" SW	1		
—5	944A0108H05	Flange, 1-1/2" SW - 300# ANSI	2		
	944A0108H07	Flange, 2-1/2" SW - 300# ASME, RFSW	2		
—6	959A0054H25	Gasket, 1-1/2" - 300# Flange	2		
	959A0054H27	Gasket, 2-1/2" - 300# Flange	2		
—7	901A0172H03	Bolt Kit, Flange, 1-1/2" - 300# ANSI	2		
	901A0172H05	Bolt Kit, Flange, 2-1/2" - 300# ASME	2		
—8	960A0082G01	Oil Pump Assembly, 1 HP, 208/230/460-3-60	1		
	960A0082G01	Oil Pump Assembly, 1 HP, 190/180-3-50	1		
	960A0082G02	Oil Pump Assembly, 1 HP, 575-3-60	1		
	960A0082G03	Oil Pump Assembly, 1 HP, 415-3-50	1		
	960A0082H01	Pump only	1		
	914A0015H02	Motor only	1		
	960A0066H11	Coupling only	1		
	960A0082G07	Oil Pump Assembly, 1-1/2 HP, 208/230/460-3-60	1		
	960A0082G08	Oil Pump Assembly, 1-1/2 HP, 190/380-3-50	1		
	960A0082G09	Oil Pump Assembly, 1-1/2 HP, 575-3-60	1		
	960A0082G10	Oil Pump Assembly, 1-1/2 HP, 415-3-50	1		
	960A0082H01	Pump only*	1		
	914A0015H02	Motor only	1		
	960A0066H11	Coupling only	1		

RWB II ROTARY SCREW COMPRESSOR UNIT  
SERVICE PARTS LIST



FIG. & INDEX	ITEM NUMBER	DESCRIPTION	QTY.	REV.	P & I REF.
14—	—	Liquid Injection with Oil Pump, Continued	Ref.		
—8	960A0082G11	Oil Pump Assembly, 2 HP, 208/230/460-3-60	1		
	960A0082G12	Oil Pump Assembly, 2 HP, 190/380-3-50	1		
	960A0082G13	Oil Pump Assembly, 2 HP, 575-3-60	1		
	960A0082G14	Oil Pump Assembly, 2 HP, 415-3-50	1		
	960A0082H01	Pump only*	1		
	914A0015H13	Motor only, 208/230/460-3-60	1		
	914A0015H14	Motor only, 190/380-3-50	1		
	914A0015H15	Motor only, 575-3-60	1		
	914A0015H16	Motor only, 415-3-50	1		
	960A0066H11	Coupling only	1		
	960A0082G04	Oil Pump Assembly, 3 HP, 208/230/460-3-60	1		
	960A0082G04	Oil Pump Assembly, 3 HP, 190/380-3-60	1		
	960A0082G05	Oil Pump Assembly, 3 HP, 575-3-60	1		
	960A0082G06	Oil Pump Assembly, 3 HP, 415-3-50	1		
	960A0082H02	Pump only*	1		
	914A0015H03	Motor only	1		
	960A0066H12	Coupling only	1		
	960A0083G01	Oil Pump Assembly, 5 HP, 190/380-3-50	1		
	960A0083G02	Oil Pump Assembly, 5 HP, 230/460-3-60	1		
	960A0083G03	Oil Pump Assembly, 5 HP, 415-3-50	1		
	960A0083G04	Oil Pump Assembly, 5 HP, 575-3-60	1		
	960A0083H01	Pump only	1		
	960A0077H41	Kit, Shaft Seal	1		
	914A0016H02	Motor only, 190/380-3-50, 230/460-3-60	1		
	914A0016H20	Motor only, 415-3-50	1		
	914A0016H23	Motor only, 575-3-60	1		
	960A0067H13	Coupling only	1		
—9	956A0014H01	Check Valve, Inline, 3/4" NPT	1		
	956A0014H02	Check Valve, Inline, 1" NPT	1		

\* Shaft Seal Kit - 960A0076H41

This page left blank intentionally.

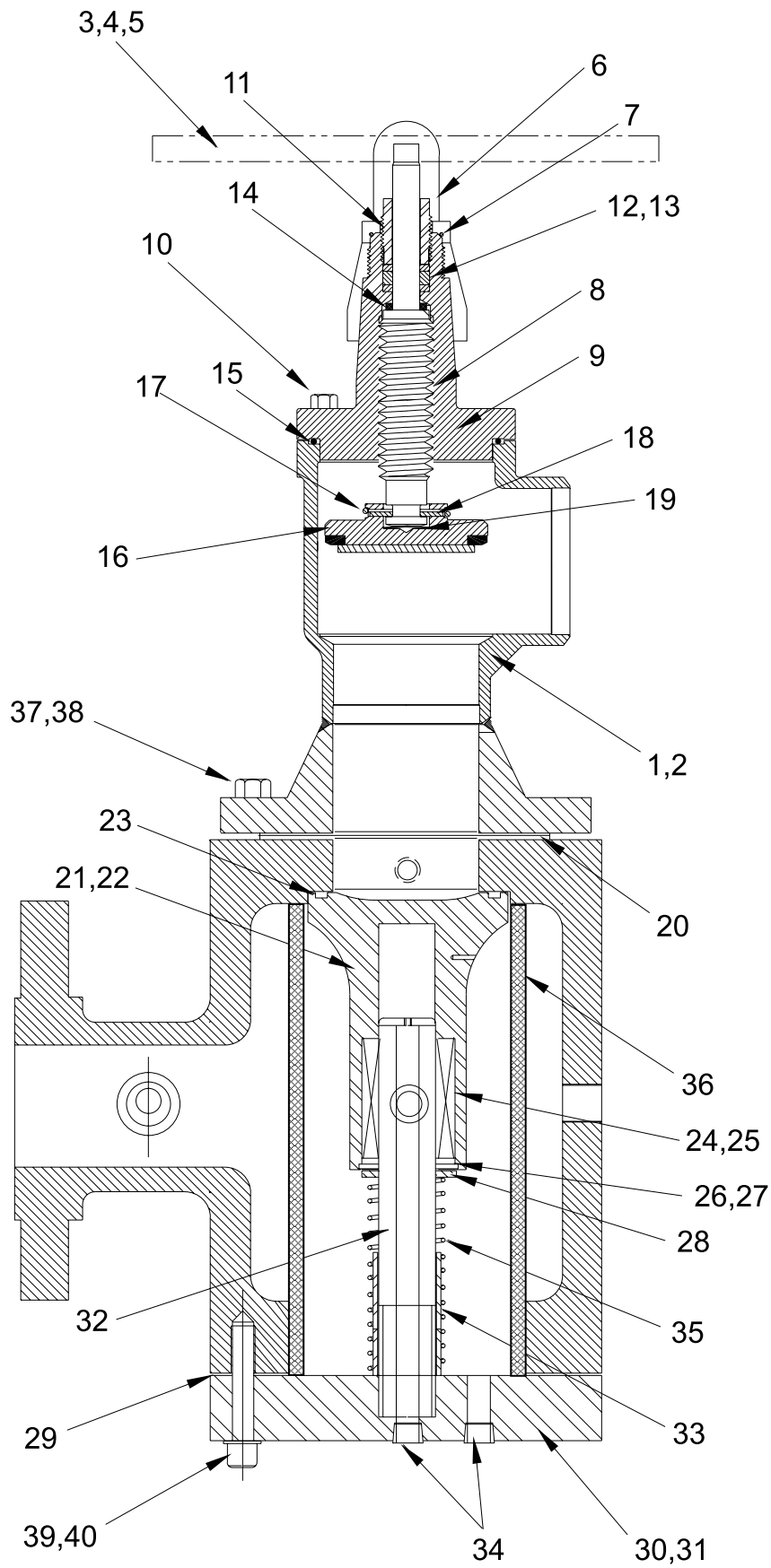

Figure 15. 4" Multivalve, Frick®

FIG. & INDEX	ITEM NUMBER	DESCRIPTION	QTY.	REV.	P & I REF.
15—	535D0402G01	Assembly, Multivalve, 4", 150 PSIG, HW	Ref.	B	
	535D0402G02	Assembly, Multivalve, 4", 150 PSIG, SC	Ref.	B	
—1	535C0232G09	Assembly, Valve, Handwheel	1		
—2	535C0232G01	Assembly, Valve, Seal Cap	1		
—3	581B0001H03	Handwheel	1		
—4	111Q0110110	Capscrew	1		
—5	581A0011H07	Washer, Spring	1		
—6	581C0001H09	Seal Cap	1		
—7	580A0275H02	Gasket	1		
—8	581B0030H03	Stem	1		
—9	581C0087C03	Bonnet	1		
—10	901A0047A05	Capscrew	4		
—11	581B0032H01	Packing Nut	1		
—12	959A0055H12	Packing Ring, Split	2		
—13	959A0056H12	Packing Ring, Center	1		
—14	581B0033H02	Seal, Backseat	1		
—15	959A0022H06	Gasket, Bonnet (original)	1		
	980A0014H59	O-Ring, Bonnet (later)	1		
—16	581C0046G06	Assembly, Button	1		
—17	580A0096H01	Retainer Ring	1		
—18	580A0090H02	Dowel Pin	4		
—19	581A0022H02	Washer, Spring	1		
—20	959A0062H01	Gasket, Body, 150/300 PSIG	1		
—21	580B0240G02	Assembly, Sliding Button	1		
—22	580C0254C02	Sliding Button	1		
—23	111Q0452526	O-Ring	1		
—24	580B0242G01	Assembly, Bearing	1		
—25	580A0235H01	Liner, TFE	1		
—26	111Q0452524	Ring, Retaining	1		
—27	111Q0940169	Washer, Flat	1		
—28	111Q0940163	Washer, Flat	1		
—29	580B0241H01	Gasket, End Cover	1		
—30	580B0246G02	Assembly, End Cover	1		
—31	580B0271H01	End Cover	1		
—32	580B0273H02	Shaft, Check Valve	1		
—33	580A0231H01	Spacer, Check Valve	1		
—34	944A0008H02	Pipe Plug	2		
—35	580A0226H01	Spring	1		
—36	580C0255H02	Strainer	1		
—37	901A0046A04	Capscrew, 150 PSIG	8		
	901A0046D04	Capscrew, 300 PSIG	8		
—38	111Q0940022	Lockwasher, 150/300 PSIG	8		
—39	111Q0740666	Capscrew	12		
—40	111Q0940019	Lockwasher	12		

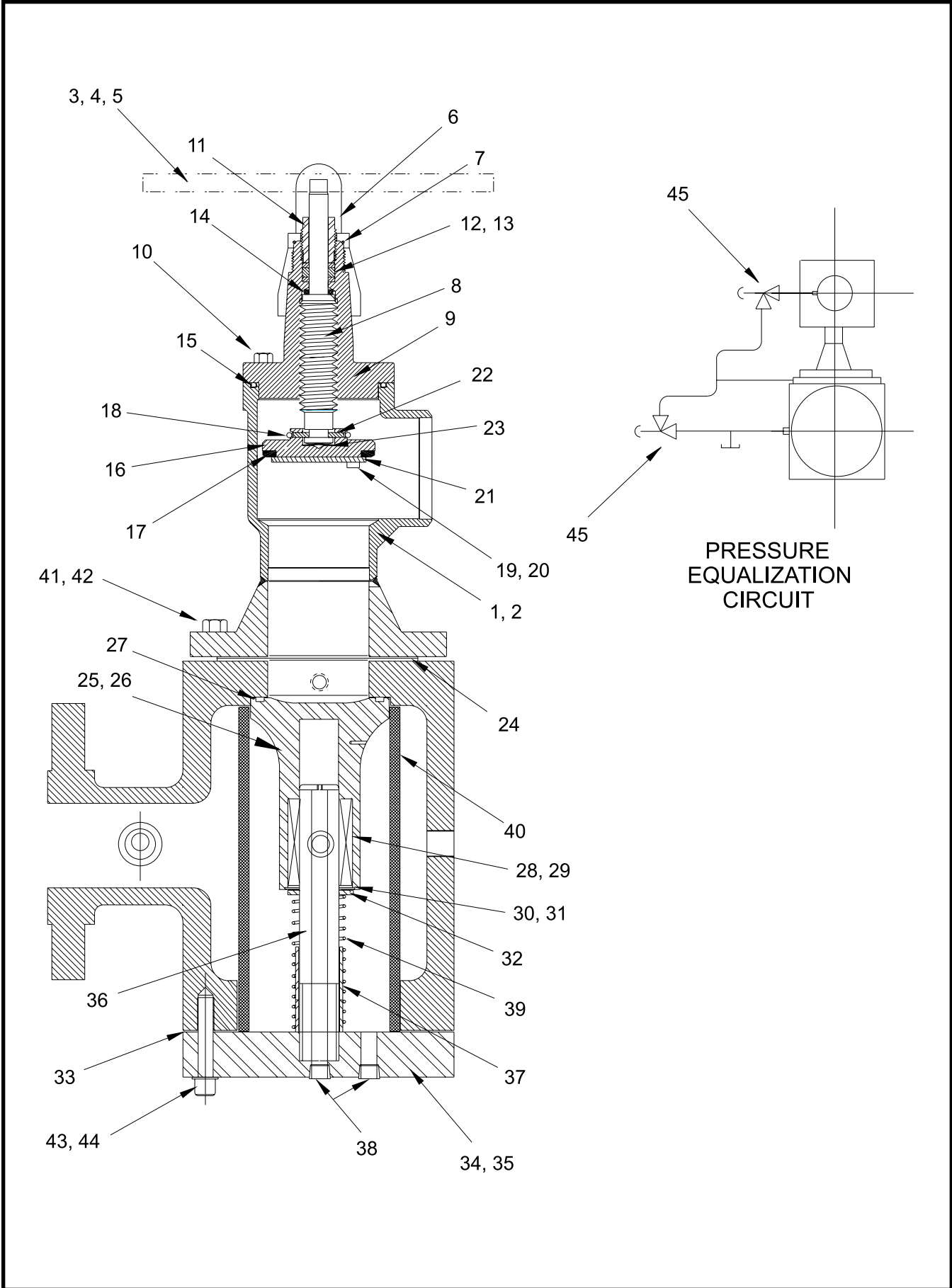

Figure 16. 5"—8" Multivalve, Frick®

FIG. & INDEX	ITEM NUMBER	DESCRIPTION	QTY.	REV.	P & I REF.
16—	535D0403G01	Assembly, Multivalve, 5", 150 PSIG, HW	Ref.	B	
	535D0403G02	Assembly, Multivalve, 5", 150 PSIG, SC	Ref.	B	
—1	535C0232G10	Assembly, Valve, Handwheel	1		
—2	535C0232G02	Assembly, Valve, Seal Cap	1		
—3	581B0001H04	Handwheel	1		
—4	581A0010H03	Capscrew	1		
—5	111Q0940048	Washer, Spring	1		
—6	581C0001H04	Seal Cap	1		
—7	580A0275H03	Gasket, Seal Cap	1		
—8	581C0037H01	Stem	1		
—9	581C0048C01	Bonnet	1		
—10	111Q0110603	Capscrew	6		
—11	581A0024H01	Packing Nut	1		
—12	959A0055H06	Packing Ring, Split	2		
—13	959A0056H06	Packing Ring, Center	1		
—14	581A0023H01	Seal, Backseat	1		
—15	959A0022H07	Gasket, Bonnet (original)	1		
	980A0014H67	O-ring, Bonnet (later)	1		
—16	581C0049C01	Button	1		
—17	581A0040H01	Button Seal	1		
—18	580A0096H01	Retainer Ring	1		
—19	901A0043B03	Capscrew	3		
—20	111Q0940012	Lockwasher	4		
—21	581A0016H01	Retaining Plate	1		
—22	580A0090H02	Dowel Pin	8		
—23	580A0095H01	Spring Disk	1		
—24	959A0062H02	Gasket, Body, 150/300 PSIG	1		
—25	580B0240G04	Assembly, Sliding Button	1		
—26	580C0252C02	Sliding Button	1		
—27	111Q0452527	O-ring	1		
—28	580B0242G01	Assembly, Bearing	1		
—29	580A0235H01	Liner, TFE	1		
—30	111Q0452524	Ring, Retaining	1		
—31	111Q0940169	Washer, Flat	1		
—32	111Q0940163	Washer, Flat	1		
—33	959A0061H02	Gasket, End Cover	1		
—34	580B0246G04	Assembly, End Cover	1		
—35	580B0272H01	End Cover	1		
—36	580B0273H04	Shaft, Check Valve	1		
—37	580A0231H02	Spacer, Check Valve	1		
—38	944A0008H02	Pipe Plug	2		
—39	580A0227H01	Spring	1		
—40	580C0250H02	Strainer	1		
—41	901A0047A05	Capscrew, 150 PSIG	8		
	901A0047D05	Capscrew, 300 PSIG	8		
—42	111Q0940026	Lockwasher, 150/300 PSIG	8		
—43	111Q0740666	Capscrew	12		
—44	111Q0940019	Lockwasher	12		

RWB II ROTARY SCREW COMPRESSOR UNIT  
SERVICE PARTS LIST



FIG. & INDEX	ITEM NUMBER	DESCRIPTION	QTY.	REV.	P & I REF.
16—	535D0404G01	Assembly, Multivalve, 6", 150 PSIG, HW	Ref.	B	
	535D0404G02	Assembly, Multivalve, 6", 150 PSIG, SC	Ref.	B	
—1	535C0232G11	Assembly, Valve, Handwheel	1		
—2	535C0232G03	Assembly, Valve, Seal Cap	1		
—3	581B0001H04	Handwheel	1		
—4	581A0010H03	Capscrew	1		
—5	581A0011H02	Washer, Spring	1		
—6	581C0001H04	Seal Cap	1		
—7	580A0275H03	Gasket, Seal Cap	1		
—8	581C0045H01	Stem	1		
—9	581D0033C01	Bonnet	1		
—10	111Q0110603	Capscrew	8		
—11	581A0024H01	Packing Nut	1		
—12	959A0055H01	Packing Ring, Split	2		
—13	959A0056H01	Packing Ring, Center	1		
—14	581A0023H01	Seal, Backseat	1		
—15	959A0022H08	Gasket, Bonnet (original)	1		
	980A0014H71	O-ring, Bonnet (later)	1		
—16	580C0044C01	Button	1		
—17	581A0040H02	Button Seal	1		
—18	580A0096H01	Retainer Ring	1		
—19	901A0043B03	Capscrew	4		
—20	111Q0940012	Lockwasher	4		
—21	581A0015H01	Retaining Plate	1		
—22	580A0090H02	Dowel Pin	8		
—23	580A0095H01	Spring Disk	1		
—24	959A0062H03	Gasket, Body, 150/300 PSIG	1		
—25	580B0240G04	Assembly, Sliding Button	1		
—26	580C0252C02	Sliding Button	1		
—27	111Q0452527	O-ring	1		
—28	580B0242G01	Assembly, Bearing	1		
—29	580A0235H01	Liner, TFE	2		
—30	111Q0452524	Retaining Ring	1		
—31	111Q0940169	Washer, Flat	1		
—32	111Q0940163	Washer, Flat	1		
—33	959A0061H02	Gasket, End Cover	1		
—34	580B0246G04	Assembly, End Cover	1		
—35	580B0272H01	End Cover	1		
—36	580B0273H04	Shaft, Check Valve	1		
—37	580A0231H02	Spacer, Check Valve	1		
—38	944A0008H02	Pipe Plug	2		
—39	580A0227H01	Spring	1		
—40	580C0250H02	Strainer	1		
—41	901A0047A05	Capscrew, 150 PSIG	8		
	901A0047D05	Capscrew, 300 PSIG	8		
—42	111Q0940026	Lockwasher, 150/300 PSIG	8		
—43	111Q0740666	Capscrew	12		
—44	111Q0940019	Lockwasher	12		

FIG. & INDEX	ITEM NUMBER	DESCRIPTION	QTY.	REV.	P & I REF.
16—	535D0405G01	Assembly, Multivalve, 8", 150 PSIG, HW	Ref.	B	
	535D0405G02	Assembly, Multivalve, 8", 150 PSIG, SC	Ref.	B	
—1	535C0232G12	Assembly, Valve, Handwheel	1		
—2	535C0232G04	Assembly, Valve, Seal Cap	1		
—3	581B0001H05	Handwheel	1		
—4	581A0010H04	Capscrew	1		
—5	581A0011H03	Washer, Spring	1		
—6	581C0001H05	Seal Cap	1		
—7	580A0275H04	Gasket, Seal Cap	1		
—8	581C0042H01	Stem	1		
—9	581D0032C01	Bonnet	1		
—10	111Q0110603	Capscrew	8		
—11	581B0045H01	Packing Nut	1		
—12	959A0055H07	Packing Ring, Split	2		
—13	959A0056H07	Packing Ring, Center	8		
—14	581A0012H01	Seal, Backseat	1		
—15	959A0022H09	Gasket, Bonnet (original)	1		
	980A0014H80	O-Ring, Bonnet (later)	1		
—16	581C0043C01	Button	1		
—17	581A0013H03	Button Seal	1		
—18	580A0108H01	Retaining Washer	1		
—19	901A0043B03	Capscrew	5		
—20	111Q0940012	Lockwasher	5		
—21	581A0014H01	Retaining Plate	1		
—22	580A0192H01	Dowel Pin	8		
—23	580A0109H01	Disk, Spring	1		
—24	959A0062H04	Gasket, Body, 150/300 PSIG	1		
—25	580B0240G06	Assembly, Sliding Button	1		
—26	580C0251C02	Sliding Button	1		
—27	111Q0452528	O-ring	1		
—28	580B0242G01	Assembly, Bearing	1		
—29	580A0235H01	Liner, TFE	2		
—30	111Q0452524	Retaining Ring	1		
—31	111Q0940169	Washer, Flat	1		
—32	111Q0940163	Washer, Flat	1		
—33	580B0241H03	Gasket, End Cover	1		
—34	580B0246G06	Assembly, End Cover	1		
—35	580C0300H01	End Cover	1		
—36	580B0273H06	Shaft, Check Valve	1		
—37	580A0231H03	Spacer, Check Valve	1		
—38	944A0008H02	Pipe Plug	2		
—39	580A0228H01	Spring	1		
—40	580C0253H02	Strainer	1		
—41	901A0047A06	Capscrew, 150 PSIG	8		
	901A0047D06	Capscrew, 300 PSIG	8		
—42	111Q0940026	Lockwasher, 150/300 PSIG	8		
—43	111Q0740052	Capscrew	12		
—44	111Q0940022	Lockwasher	12		
—45	957A0003H02	Valve, Angle	2		

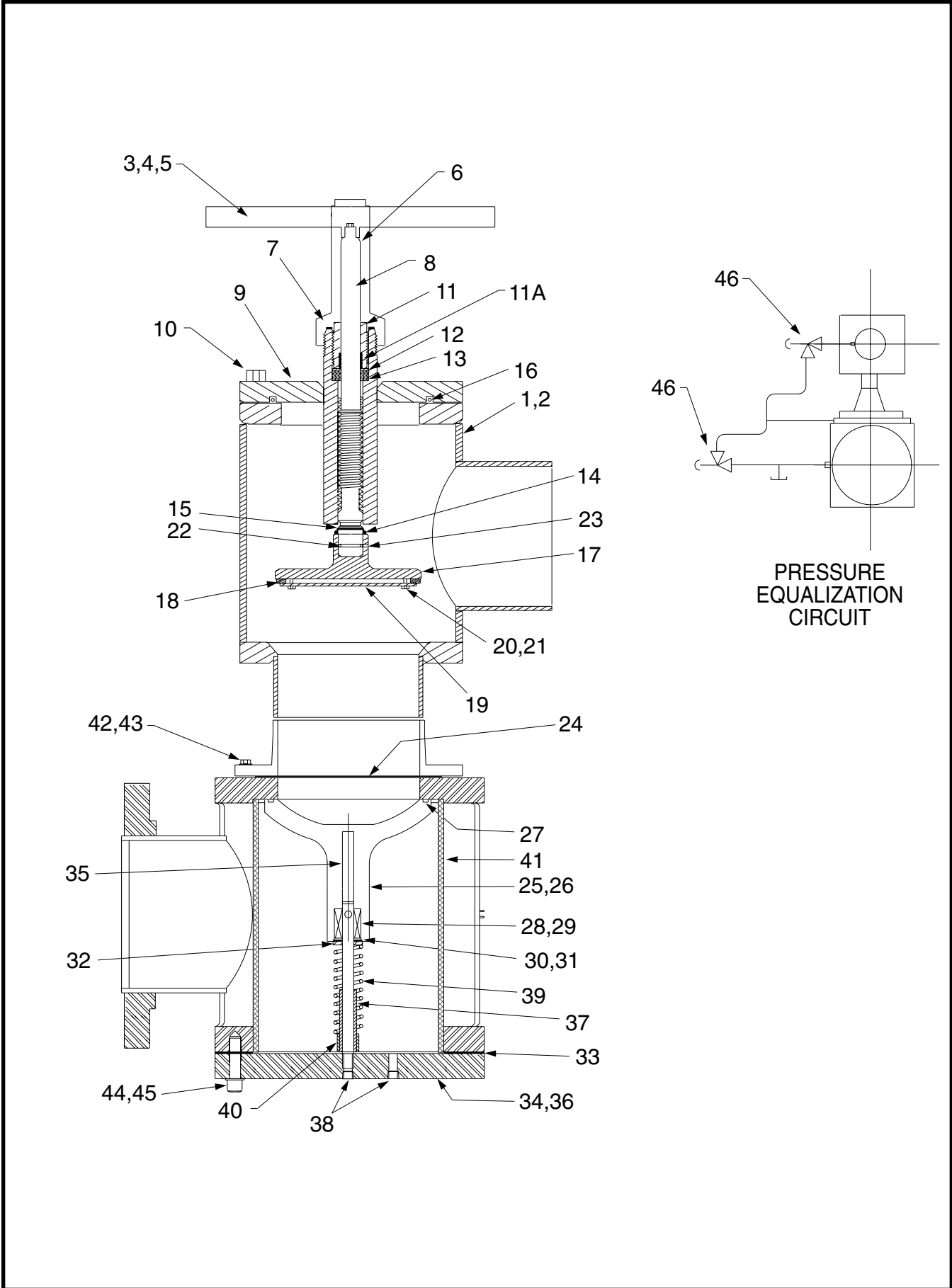

Figure 17. 10" and 14" Multivalve, Frick®

FIG. & INDEX	ITEM NUMBER	DESCRIPTION	QTY.	REV.	P & I REF.
17—	535D0406G01	Assembly, Multivalve, 10", 150 PSIG, HW	Ref.	B	
	535D0406G02	Assembly, Multivalve, 10", 150 PSIG, SC	Ref.	B	
—1	535C0232G13	Assembly, Valve, Handwheel	1		
—2	535C0232G15	Assembly, Valve, Seal Cap	1		
—3	581B0001H06	Handwheel	1		
—4	901A0045A03	Capscrew	1		
—5	581A0011H03	Washer, Spring	2		
—6	581C0050H01	Seal Cap	1		
—7	580A0275H05	Gasket, Seal Cap	1		
—8	581B0009H01	Stem	1		
—9	581C0074G01	Bonnet	1		
—10	901A0046A05	Capscrew	12		
—11	581B0066H01	Packing Nut	1		
—11A	581A0042H01	Packing Nut Bushing	1		
—12	581A0046H01	Ring, Bushing End	2		
—13	959A0076H01	Ring, Center Packing	1		
—14	581A0020H01	Seal, Backseat	1		
—15	581A0044H01	Ring, Retaining	1		
—16	581A0007H01	Gasket, Bonnet (original)	1		
	980A0014K29	O-ring, Bonnet (later)	1		
—17	581C0072G01	Button	1		
—18	581A0040H04	Button Seal	1		
—19	581A0017H01	Retaining Plate	1		
—20	111Q0110535	Capscrew	6		
—21	111Q0940012	Lockwasher	6		
—22	581A0001H04	Ball Bearing	16		
—23	581B0003H06	Retaining Clip	1		
—24	959A0062H05	Gasket, Body, 150/300 PSIG	1		
—25	580B0240G07	Assembly, Sliding Button	1		
—26	580C0262C01	Sliding Button	1		
—27	980A0014H80	O-ring	1		
—28	580B0243G01	Assembly, Bearing	1		
—29	580A0235H03	Liner, TFE	2		
—30	111Q0452525	Retaining Ring	1		
—31	111Q0940170	Washer, Flat	1		
—32	111Q0940164	Washer, Flat	1		
—33	959A0061H04	Gasket, End Cover	1		
—34	580B0246G07	Assembly, End Cover	1		
—35	580B0273H07	Shaft, Check Valve	1		
—36	580C0301H01	End Cover	1		
—37	580A0232H01	Spacer, Check Valve	1		
—38	944A0008H02	Pipe Plug	2		
—39	580A0229H01	Spring	1		
—40	580A0234H01	Spring Adjuster	1		
—41	580C0268H01	Strainer	1		
—42	901A0048A06	Capscrew, 150 PSIG	12		
	901A0048D06	Capscrew, 300 PSIG	12		
—43	111Q0940028	Lockwasher, 150/300 PSIG	12		
—44	111Q0740822	Capscrew	16		
—45	111Q0940028	Lockwasher	16		
—46	957A0003H02	Valve, Angle	2		

RWB II ROTARY SCREW COMPRESSOR UNIT  
SERVICE PARTS LIST



FIG. & INDEX	ITEM NUMBER	DESCRIPTION	QTY.	REV.	P & I REF.
17—	535D0460G01	Assembly, Multivalve, 12", 300 PSIG, HW*	Ref.	B	
	535D0460G02	Assembly, Multivalve, 12", 300 PSIG, SC*	Ref.	B	
—1	535C0232G14	Assembly, Valve, Handwheel	1		
—2	535C0232G16	Assembly, Valve, Seal Cap	1		
—3	581B0001H07	Handwheel	1		
—4	901A0046H01	Capscrew	1		
—5	581A0011H04	Washer, Spring	1		
—6	581C0051H01	Seal Cap	1		
—7	580A0275H06	Gasket	1		
—8	581B0010H01	Stem	1		
—9	581C0078H01	Bonnet	1		
—10	901A0046A05	Capscrew	16		
—11	581B0067H01	Packing Nut	1		
—11A	581A0043H01	Packing Nut Bushing	1		
—12	581A0047H01	Ring, Bushing End	2		
—13	959A0076H02	Ring, Center Packing	1		
—14	581A0030H01	Seal, Backseat	1		
—15	581A0044H02	Retaining Ring	1		
—16	980A0014K33	O-ring, Bonnet	1		
—17	581C0071G01	Button	1		
—18	581A0040H05	Button Seal	1		
—19	581A0019H01	Retaining Plate	1		
—20	111Q0110535	Capscrew	6		
—21	111Q0940012	Lockwasher	6		
—22	581A0001H04	Ball Bearing	18		
—23	581B0003H07	Retaining Clip	1		
—24	959A0038H06	Gasket, Body	1		
—25	580B0240G08	Assembly, Sliding Button	1		
—26	580C0264C01	Sliding Button	1		
—27	111Q0452530	O-ring	1		
—28	580B0243G01	Assembly, Bearing	1		
—29	580A0235H03	Liner, TFE	2		
—30	111Q0452525	Retaining Ring	1		
—31	111Q0940170	Washer, Flat	1		
—32	111Q0940164	Washer, Flat	1		
—33	959A0061H05	Gasket, End Cover	1		
—34	580B0246G08	Assembly, End Cover	1		
—35	580B0273H08	Shaft, Check Valve	1		
—36	580C0302H01	End Cover	1		
—37	580A0232H02	Spacer, Check Valve	1		
—38	944A0008H02	Pipe Plug	2		
—39	580A0230H01	Spring	1		
—40	580A0234H02	Spring Adj.	1		
—41	580C0269H01	Strainer	1		
—42	901A0048A07	Capscrew	12		
—43	111Q0940028	Lockwasher	12		
—44	901A0048A07	Capscrew	16		
—45	111Q0940028	Lockwasher	16		
—46	580D0047G02	Valve, Angle	2		
	* 12" inlet, 14" outlet				
	NOT SHOWN:				
	535D0516G01	Assembly, Multivalve, 14", 150 PSIG, HW (Hansen/Frick)	Ref.	—	
	950A0169G01	Assembly, Valve, Angle, Stop, 14", HW (Hansen)	1		
	535D0516G02	Assembly, Multivalve, 14", 150 PSIG, SC (Hansen/Frick)	Ref.	—	
	950A0169G02	Assembly, Valve, Angle, Stop, 14", SC (Hansen)	1		

This page left blank intentionally.

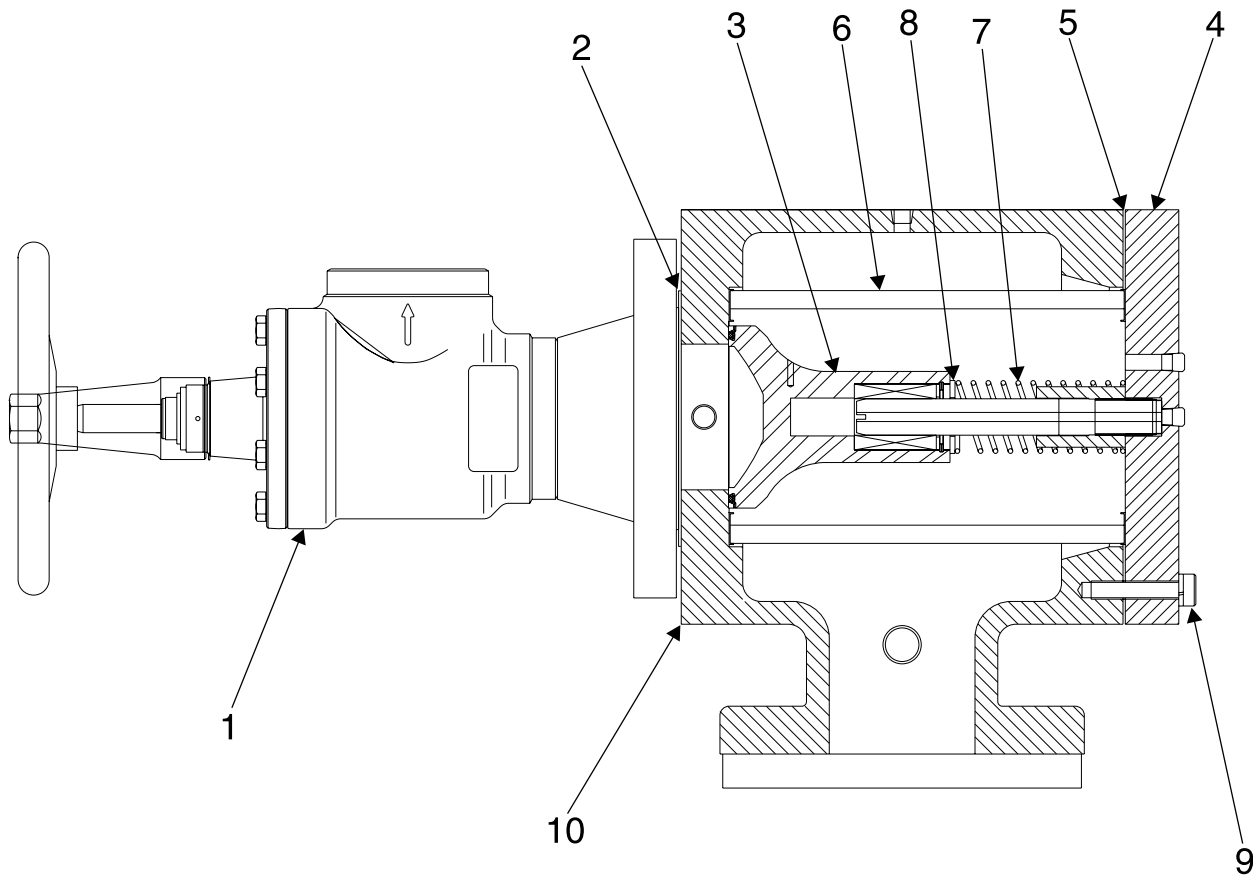

**NOTE: THIS FIGURE SHOWS SUCTION TRAP ASSEMBLY FOR MULTIVALVES WITH DANFOSS STOP VALVES. FOR PARTS TO GRAM STOP VALVE, SEE FIGURES 21 & 22, GRAM STOP/CHECK VALVE.**

**Figure 18.4 — 8" Multivalve, Current (Danfoss)**

FIG. & INDEX	ITEM NUMBER	DESCRIPTION	QTY.	REV.	P & I REF.
18—	582D0025	Assembly, Multivalve, 4", 150 PSI	Ref.	—	
	582D0026	Assembly, Multivalve, 5", 150 PSI	Ref.	—	
	582D0027	Assembly, Multivalve, 6", 150 PSI	Ref.	—	
	582D0028	Assembly, Multivalve, 8", 150 PSI	Ref.	—	
	582D0029	Assembly, Multivalve, 4", 300 PSI	Ref.	—	
	582D0030	Assembly, Multivalve, 5", 300 PSI	Ref.	—	
	582D0031	Assembly, Multivalve, 6", 300 PSI	Ref.	—	
	582D0032	Assembly, Multivalve, 8", 300 PSI	Ref.	—	
—1	950A0240H09	Valve, Angle, 4"	1		
	950A0240H10	Valve, Angle, 5"	1		
	950A0240H11	Valve, Angle, 6"	1		
	950A0240H12	Valve, Angle, 8"	1		
	950A0240H26	Spare Parts Kit, Complete*, 4"	1		
	950A0240H27	Spare Parts Kit, Complete*, 5"	1		
	950A0240H28	Spare Parts Kit, Complete*, 6"	1		
	950A0240H29	Spare Parts Kit, Complete*, 8"	1		
	950A0240H34	Packing Gland Spare Parts Kit, 4"	1		
	950A0240H35	Packing Gland Spare Parts Kit, 5" & 6"	1		
	950A0240H36	Packing Gland Spare Parts Kit, 8"	1		
	950A0240H46	Cone Spare Parts Kit, 4"	1		
	950A0240H47	Cone Spare Parts Kit, 5"	1		
	950A0240H48	Cone Spare Parts Kit, 6"	1		
	950A0240H49	Cone Spare Parts Kit, 8"	1		
	950A0240H55	Handwheel Spare Parts Kit, 4"	1		
	950A0240H56	Handwheel Spare Parts Kit, 5" & 6"	1		
	950A0240H57	Handwheel Spare Parts Kit, 8"	1		
—2	959A0062H01	Gasket, Multivalve, 4", 150 PSI	1		
	959A0062H02	Gasket, Multivalve, 5", 150 PSI	1		
	959A0062H03	Gasket, Multivalve, 6", 150 PSI	1		
	959A0062H04	Gasket, Multivalve, 8", 150 PSI	1		
	959A0062H21	Gasket, Multivalve, 4", 300 PSI	1		
	959A0062H22	Gasket, Multivalve, 5", 300 PSI	1		
	959A0062H23	Gasket, Multivalve, 6", 300 PSI	1		
	959A0062H24	Gasket, Multivalve, 8", 300 PSI	1		
—3	580B0240G02	Assembly, Sliding Button, 4"	1		
	580B0240G04	Assembly, Sliding Button, 5" & 6"	1		
—4	580B0240G06	Assembly, Sliding Button, 8"	1		
	580B0246G02	Assembly, End Cover, 4"	1		
	580B0246G04	Assembly, End Cover, 5"	1		
	580B0246G04	Assembly, End Cover, 5" & 6"	1		
	580B0246G06	Assembly, End Cover, 8"	1		
—5	959A0061H01	Gasket, End Cover, 4"	1		
	959A0061H02	Gasket, End Cover, 5" & 6"	1		
	959A0061H03	Gasket, End Cover, 8"	1		
—6	580C0255H02	Strainer, Double Screen, 4"	1		
	580C0250H02	Strainer, Double Screen, 5" & 6"	1		
	580C0253H02	Strainer, Double Screen, 8"	1		
—7	580A0226H01	Spring, Return, 4"	1		
	580A0227H01	Spring, Return, 5" & 6"	1		
	580A0228H01	Spring, Return, 8"	1		
—8	111Q0940163	Washer	1		
—9	111Q0740666	Capscrew, Socket Head, 1/2 NC x 2-1/2", 4" — 6"	12		
	111Q0740052	Capscrew, Socket Head, 5/8 NC x 2-1/2", 8"	12		
	111Q0940019	Washer, Lock, 1/2"	12		
	111Q0940022	Washer, Lock, 5/8"	12		
—10	535D0190C02	Body, Suction Trap, 4", 150/300 PSI	1		
	535D0196C02	Body, Suction Trap, 5", 150/300 PSI	1		
	535D0195C02	Body, Suction Trap, 6", 150/300 PSI	1		
	535D0191C02	Body, Suction Trap, 8", 150/300 PSI	1		

Note- Hardware connecting Angle Valve and Suction Trap: 4" & 5" - 901A0047D06 3/4 x 2-1/4"; 6" - 901A0047D07 3/4 x 2-1/2"; 8" - 901A0048D08 7/8 x 2-3/4".

\* Complete Spare Parts Kit consists of cone & seal, packing gland, set screw, steel balls, o-ring, cap gasket, soft back seat (less stem).

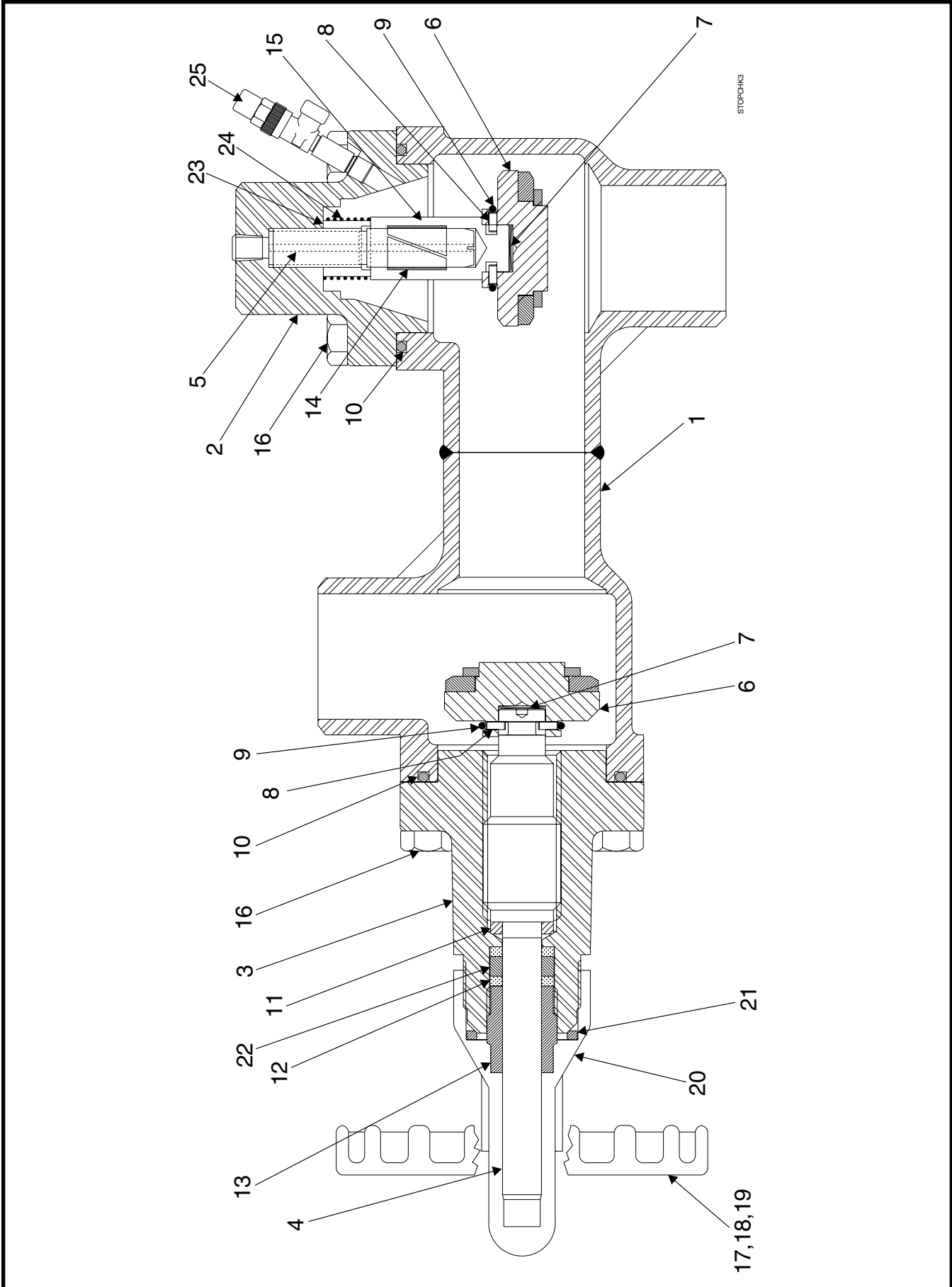

Figure 19. 3" and 4" Discharge Stop/Check Valve (Frick).

FIG. & INDEX	ITEM NUMBER	DESCRIPTION	QTY.	REV.	P & I REF.
19—	581C0107G01	3" Discharge Stop/Check Valve, R-717 (Frick)	Ref.	B	
	581C0107G02	3" Discharge Stop/Check Valve, R-22 (Frick)	Ref.	B	
	581C0109G01	4" Discharge Stop/Check Valve, R-717 (Frick)	Ref.	B	
	581C0109G02	4" Discharge Stop/Check Valve, R-22 (Frick)	Ref.	B	
—1	581C0110G01	Body, Valve, 3"	1		
	581C0110G02	Body, Valve, 4"	1		
—2	581C0104C01	Bonnet, Check Valve, 3"	1		
	581C0105C01	Bonnet, Check Valve, 4"	1		
—3	581C0086C02	Bonnet, Stop Valve, 3"	1		
	581C0087C03	Bonnet, Stop Valve, 4"	1		
—4	581B0030H02	Stem, Stop Valve, 3"	1		
	581B0030H03	Stem, Stop Valve, 4"	1		
—5	581B0100H05	Shaft, Sliding Button, 3"	1		
	581B0100H04	Shaft, Sliding Button, 4"	1		
—6	581C0046G05	Button Assembly, 3"	2		
	581C0046G06	Button Assembly, 4"	2		
—7	581A0022H02	Washer, Spring	2		
—8	580A0090H02	Pin, Button	8		
—9	580A0096H01	Ring, Retaining	2		
—10	980A0014H51	O-ring, Bonnet, 3"	2		
	980A0014H59	O-ring, Bonnet, 4"	2		
—11	581B0033H02	Seal, Backseat	1		
—12	959A0055H12	Ring, Packing, Split	2		
—13	581B0032H01	Nut, Packing	1		
—14	580A0235H01	Ring, Packing, Split, 3"	1		
	581A0027H01	Ring, Packing, Split, 4"	1		
—15	581B0052H05	Guide Bushing, Sliding Button, 3"	1		
	581B0052H04	Guide Bushing, Sliding Button, 4"	1		
—16	901A0046A04	Capscrew, Hex Head, 3"	8		
	901A0047A05	Capscrew, Hex Head, 4"	8		
—17	581B0001H03	Handwheel	1		
—18	581A0011H07	Washer, Spring	1		
—19	581A0010H03	Capscrew, Hex Head	1		
—20	581C0001H09	Seal Cap	1		
—21	580A0275H02	Gasket, Seal Cap	1		
—22	959A0056H12	Ring, Packing, Center	1		
—23	580A0219H03	Spacer, Check Valve, 3"	1		
	580A0219H01	Spacer, Check Valve, 4"	1		
—24	580A0223H01	Spring, Return, 3"	1		
	580A0218H01	Spring, Return, 4"	1		
—25	957A0003H01	Valve, Angle, SC, 1/4 FPT x 1/4 MPT	1		

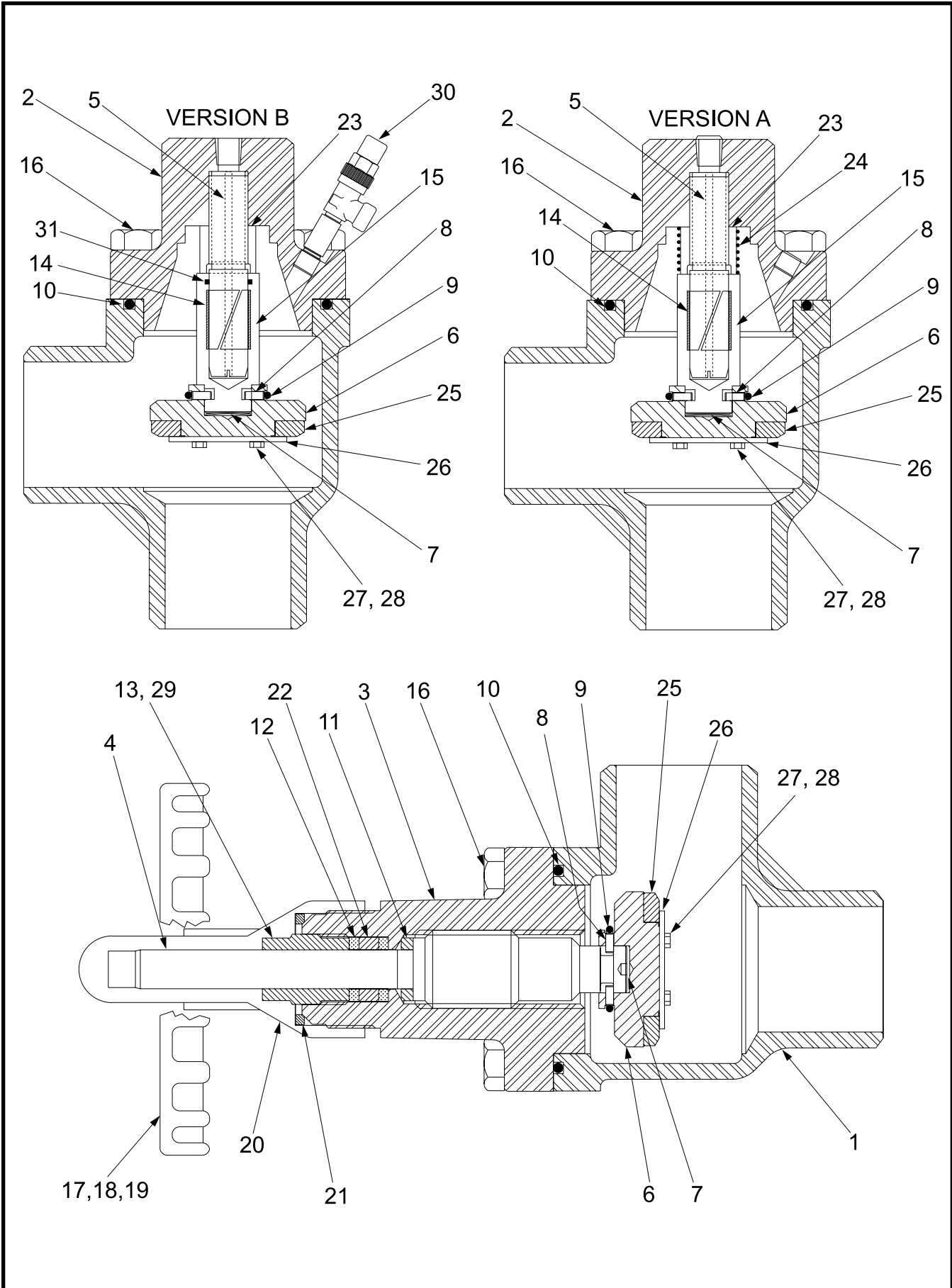

Figure 20. 5"—8" Discharge Stop/Check Valve (Frick).

FIG. & INDEX	ITEM NUMBER	DESCRIPTION	QTY.	REV.	P & I REF.
20—	581C0062G01	5" Discharge Stop/Check Valve, High Stage, R-717 (Frick)	Ref.	D	
	581C0062G02	5" Discharge Stop/Check Valve, High Stage, R-22 (Frick)	Ref.	D	
	581C0145G01	5" Discharge Stop/Check Valve, Booster, R-717 (Frick)	Ref.	—	
	581C0145G02	5" Discharge Stop/Check Valve, Booster, R-22 (Frick)	Ref.	—	
—1	581C0110G03	Body, Valve, 5"	1		
—2	581C0063C01	Bonnet, Check Valve	1		
—3	581C0048C01	Bonnet, Stop Valve	1		
—4	581C0037H01	Stem, Stop Valve	1		
—5	581B0100H03	Shaft, Sliding Button	1		
—6	581C0144C01	Button	2		
—7	580A0095H01	Spring	2		
—8	580A0090H02	Pin, Button	16		
—9	580A0096H01	Ring, Retaining	2		
—10	980A0014H67	O-ring, Bonnet	2		
—11	581A0023H01	Seal, Backseat	1		
—12	959A0055H06	Ring, Packing, Split	2		
—13	581A0024H01	Nut, Packing	1		
—14	581A0027H01	Ring, Packing, Split	1		
—15	581B0082H01	Guide Bushing, Sliding Button	1		
—16	901A0046A03	Capscrew, Hex Head	12		
—17	581B0001H04	Handwheel	1		
—18	581A0011H07	Washer, Spring	1		
—19	581A0010H03	Capscrew, Hex Head	1		
—20	581C0001H04	Seal Cap	1		
—21	580A0275H03	Gasket, Seal Cap	1		
—22	959A0056H06	Ring, Packing Center	1		
—23	580A0219H01	Spacer, Check Valve	1		
—24	580A0218H01	Spring, Return, High Stage Application	1		
—25	581A0040H01	Seal, Button	2		
—26	581A0016H01	Plate, Retaining	2		
—27	901A0043E03	Capscrew, Hex Head	6		
—28	111Q0940012	Lockwasher	6		
—29	580A0183H06	Washer, Packing	1		
—30	957A0003H01	Valve, Angle, SC, 1/4 FPT x 1/4 MPT	1		
—31	581B0086H01	Ring, Seal, PTFE	1		

RWB II ROTARY SCREW COMPRESSOR UNIT  
SERVICE PARTS LIST



FIG. & INDEX	ITEM NUMBER	DESCRIPTION	QTY.	REV.	P & I REF.
20—	581C0053G01	6" Discharge Stop/Check Valve, High Stage, R-717 (Frick)	Ref.	C	
	581C0053G02	6" Discharge Stop/Check Valve, High Stage, R-22 (Frick)	Ref.	C	
	581C0143G01	6" Discharge Stop/Check Valve, Booster, R-717 (Frick)	Ref.	—	
	581C0143G02	6" Discharge Stop/Check Valve, Booster, R-717 (Frick)	Ref.	—	
—1	581C0110G04	Body, Valve, 6"	1		
—2	581D0045C01	Bonnet, Check Valve	1		
—3	581D0033C01	Bonnet, Stop Valve	1		
—4	581C0045H01	Stem, Stop Valve	1		
—5	581B0100H02	Shaft, Sliding Button	1		
—6	581C0142C01	Button	2		
—7	580A0095H01	Spring	2		
—8	580A0090H02	Pin, Button	16		
—9	580A0096H01	Ring, Retaining	2		
—10	980A0014H71	O-ring, Bonnet	2		
—11	581A0023H01	Seal, Backseat	1		
—12	959A0055H06	Ring, Packing, Split	2		
—13	581A0024H01	Nut, Packing	1		
—14	581A0027H01	Ring, Packing, Split	1		
—15	581B0081H01	Guide Bushing, Sliding Button	1		
—16	901A0046A03	Capscrew, Hex Head	16		
—17	581B0001H04	Handwheel	1		
—18	581A0011H07	Washer, Spring	1		
—19	581A0010H03	Capscrew, Hex Head	1		
—20	581C0001H04	Seal Cap	1		
—21	580A0275H03	Gasket, Seal Cap	1		
—22	959A0056H06	Ring, Packing, Center	1		
—23	580A0219H01	Spacer, Check Valve	1		
—24	580A0218H01	Spring, Return, High Stage Application	1		
—25	581A0040H02	Seal, Button	2		
—26	581A0015H01	Plate, Retaining	2		
—27	901A0043E03	Capscrew, Hex Head	8		
—28	111Q0940012	Lockwasher	8		
—29	580A0183H06	Washer, Packing	1		
—30	957A0003H01	Valve, Angle, SC, 1/4 FPT x 1/4 MPT	1		
—31	581B0086H01	Ring, Seal, PTFE	1		

FIG. & INDEX	ITEM NUMBER	DESCRIPTION	QTY.	REV.	P & I REF.
20—	581C0065G01	8" Discharge Stop/Check Valve, High Stage, R-717 (Frick)	Ref.	D	
	581C0065G02	8" Discharge Stop/Check Valve, High Stage, R-22 (Frick)	Ref.	D	
	581C0141G01	8" Discharge Stop/Check Valve, Booster, R-717 (Frick)	Ref.	—	
	581C0141G02	8" Discharge Stop/Check Valve, Booster, R-22 (Frick)	Ref.	—	
—1	581C0110G05	Body, Valve, 8"	1		
—2	581D0047C01	Bonnet, Check Valve	1		
—3	581D0032C01	Bonnet, Stop Valve	1		
—4	581C0042H01	Stem, Stop Valve	1		
—5	581B0100H01	Shaft, Sliding Button	1		
—6	581C0139C01	Button	2		
—7	580A0109H01	Spring	2		
—8	580A0192H01	Pin, Button	16		
—9	580A0108H01	Ring, Retaining	2		
—10	980A0014H80	O-ring, Bonnet	2		
—11	581A0012H01	Seal, Backseat	1		
—12	959A0055H07	Ring, Packing, Split	2		
—13	581B0045H01	Nut, Packing	1		
—14	581A0027H02	Ring, Packing, Split	1		
—15	581B0080H01	Guide Bushing, Sliding Button	1		
—16	901A0046D03	Capscrew, Hex Head	16		
—17	581B0001H05	Handwheel	1		
—18	581A0011H03	Washer, Spring	1		
—19	581A0010H04	Capscrew, Hex Head	1		
—20	581C0001H05	Seal Cap	1		
—21	580A0275H04	Gasket, Seal Cap	1		
—22	959A0056H07	Ring, Packing, Center	1		
—23	580A0219H04	Spacer, Check Valve	1		
—24	111Q0019539	Spring, Return, High Stage Application	1		
—25	581A0040H03	Button, Seal	2		
—26	581A0014H01	Plate, Retaining	2		
—27	901A0043E03	Capscrew, Hex Head	10		
—28	111Q0940012	Lockwasher	10		
—29	580A0183H07	Washer, Packing	1		
—30	957A0003H01	Valve, Angle, SC, 1/4 FPT x 1/4 MPT	1		
—31	581B0086H02	Ring, Seal, PTFE	1		

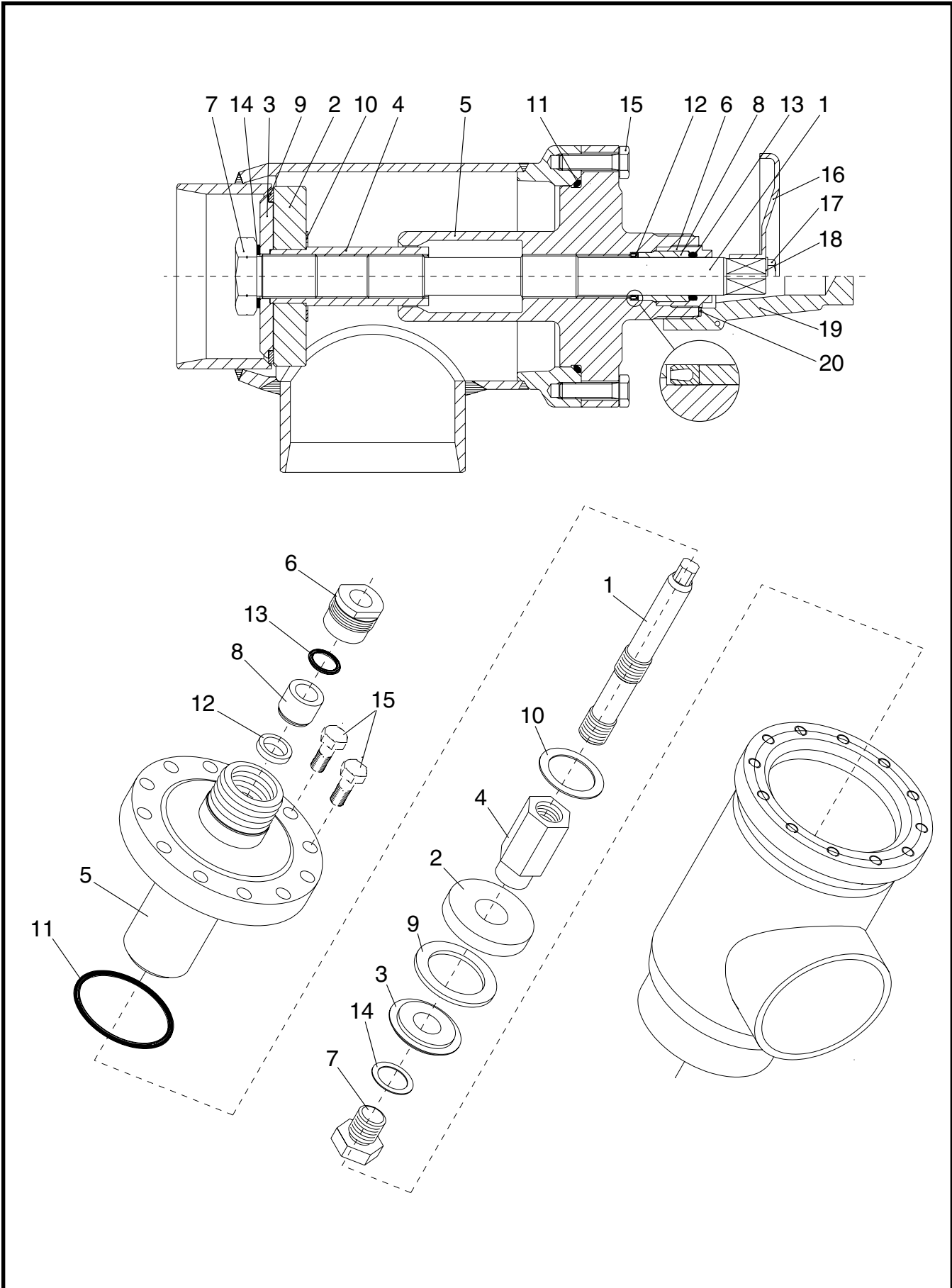

Figure 21. 3"— 6" Discharge Stop Valve (Gram).

FIG. & INDEX	ITEM NUMBER	DESCRIPTION	QTY.	REV.	P & I REF.
21—	581C0153G01	3" Discharge Stop/Check Valve, HW (Gram/Frick)	Ref.	A	
	581C0153G02	3" Discharge Stop/Check Valve, SC (Gram/Frick)	Ref.	A	
	581C0154G01	4" Discharge Stop/Check Valve, HW (Gram/Frick)	Ref.	A	
	581C0154G02	4" Discharge Stop/Check Valve, SC (Gram/Frick)	Ref.	A	
	950A0137G01	3" Stop Valve, HW (Gram)	1	C	
	950A0137G02	3" Stop Valve, SC (Gram)	1	C	
	950A0139G01	4" Stop Valve, HW (Gram)	1	C	
	950A0139G02	4" Stop Valve, SC (Gram)	1	C	
—1	724003174GR	Spindle, 3"	1		
	724003177GR	Spindle, 4"	1		
—2	724003285GR	Cone, 3"	1		
	724003287GR	Cone, 4"	1		
—3	724003235GR	Plate, 3"	1		
	724003237GR	Plate, 4"	1		
—4	724003260GR	Guide, 3"	1		
	724003262GR	Guide, 4"	1		
—5	724001061GR	Cover, Top, 3"	1		
	724001062GR	Cover, Top, 4"	1		
—6	724003460GR	Screw, Packing, 3"	1		
	724003462GR	Screw, Packing, 4"	1		
—7	724003210GR	Screw, 3"	1		
	724003212GR	Screw, 4"	1		
—8	724003485GR	Bushing, 3"	1		
	724003487GR	Bushing, 4"	1		
—9	724003310GR	Seat, 3"	1		
	724003312GR	Seat, 4"	1		
—10	724003335GR	Seal, 3"	1		
	724003337GR	Seal, 4"	1		
—11	550845339GR	O-ring, 3"	1		
	550840194GR	O-ring, 4"	1		
—12	550940233GR	U-sleeve, 3"	1		
	550940238GR	U-sleeve, 4"	1		
—13	550845210GR	O-ring, 3"	1		
	550845213GR	O-ring, 4"	1		
—14	550657045GR	Washer, 30 x 23 x 2, 3"	1		
	550657046GR	Washer, 34 x 27 x 2, 4"	1		
—15	420098167GR	Screw, Allen Head, SS, M10 x 35, 3"	10		
	420098167GR	Screw, Allen Head, SS, M10 x 35, 4"	12		
—16	480012225GR	Handwheel, 3"	1		
	480012300GR	Handwheel, 4"	1		
—17	420092125GR	Screw, M8 x 16, 3"	1		
	420092202GR	Screw, M12 x 25, 4"	1		
—18	421611056GR	Washer, M16, 3"	1		
	421642107GR	Washer, M12, 4"	1		
—19	724003612GR	Cap, 3"	1		
	724003614GR	Cap, 4"	1		
—20	724003662GR	Seal, 3"	1		
	724003664GR	Seal, 4"	1		

Note: For Check Valve parts see Figure 20.

For help in identifying valves, see S160-800 SPL - Shutoff Valve Identification Guide.

RWB II ROTARY SCREW COMPRESSOR UNIT  
SERVICE PARTS LIST



FIG. & INDEX	ITEM NUMBER	DESCRIPTION	QTY.	REV.	P & I REF.
21—	581C0155G01	5" Discharge Stop/Check Valve, R-22 (Gram/Frick)	Ref.	A	
	581C0155G02	5" Discharge Stop/Check Valve, R-717 (Gram/Frick)	Ref.	A	
	950A0141G01	5" Stop Valve, R-22 (Gram)	1	B	
	950A0141G02	5" Stop Valve, R-717 (Gram)	1	B	
—1	724003183GR	Spindle	1		
—2	724003289GR	Cone	1		
—3	724003239GR	Plate	1		
—4	724003266GR	Guide	1		
—5	724001063GR	Cover, Top	1		
—6	724003466GR	Screw, Packing	1		
—7	724003216GR	Screw	1		
—8	724003491GR	Bushing	1		
—9	724003314GR	Seat	1		
—10	724003341GR	Seal	1		
—11	550845354GR	O-ring	1		
—12	550940245GR	U-sleeve	1		
—13	550845217GR	O-ring	1		
—14	550657051GR	Washer, 44 x 32 x 2	1		
—15	420095244GR	Screw, Allen Head, SS, M16 x 45	10		
—16	480012400GR	Handwheel	1		
—17	420092241GR	Screw, M16 x 30	1		
—18	421642109GR	Washer	1		
—19	724003616GR	Cap	1		
—20	724003666GR	Seal	1		
<p>Note: For Check Valve parts see Figure 20. For help in identifying valves, see S160-800 SPL - Shutoff Valve Identification Guide.</p>					

FIG. & INDEX	ITEM NUMBER	DESCRIPTION	QTY.	REV.	P & I REF.
21—	581C0156G01	6" Discharge Stop/Check Valve, R-22 (Gram/Frick)	Ref.	A	
	581C0156G02	6" Discharge Stop/Check Valve, R-717 (Gram/Frick)	Ref.	A	
	950A0143G01	6" Stop Valve, R-22 (Gram)	1	C	
	950A0143G02	6" Stop Valve, R-717 (Gram)	1	C	
—1	724003183GR	Spindle	1		
—2	724003291GR	Cone	1		
—3	724003241GR	Plate	1		
—4	724003266GR	Guide	1		
—5	724001064GR	Cover, Top	1		
—6	724003466GR	Screw, Packing	1		
—7	724003216GR	Screw	1		
—8	724003491GR	Bushing	1		
—9	724003316GR	Seat	1		
—10	724003341GR	Seal	1		
—11	550840252GR	O-ring	1		
—12	550940245GR	U-sleeve	1		
—13	550845217GR	O-ring	1		
—14	550657051GR	Washer, 44 x 32 x 2	1		
—15	420048382GR	Screw, Allen Head, SS, M16 x 55	12		
—16	480012400GR	Handwheel	1		
—17	420092241GR	Screw, M16 x 30	1		
—18	421642109GR	Washer	1		
—19	724003616GR	Cap	1		
—20	724003666GR	Seal	1		
<p>Note: For Check Valve parts see Figure 20. For help in identifying valves, see S160-800 SPL - Shutoff Valve Identification Guide.</p>					

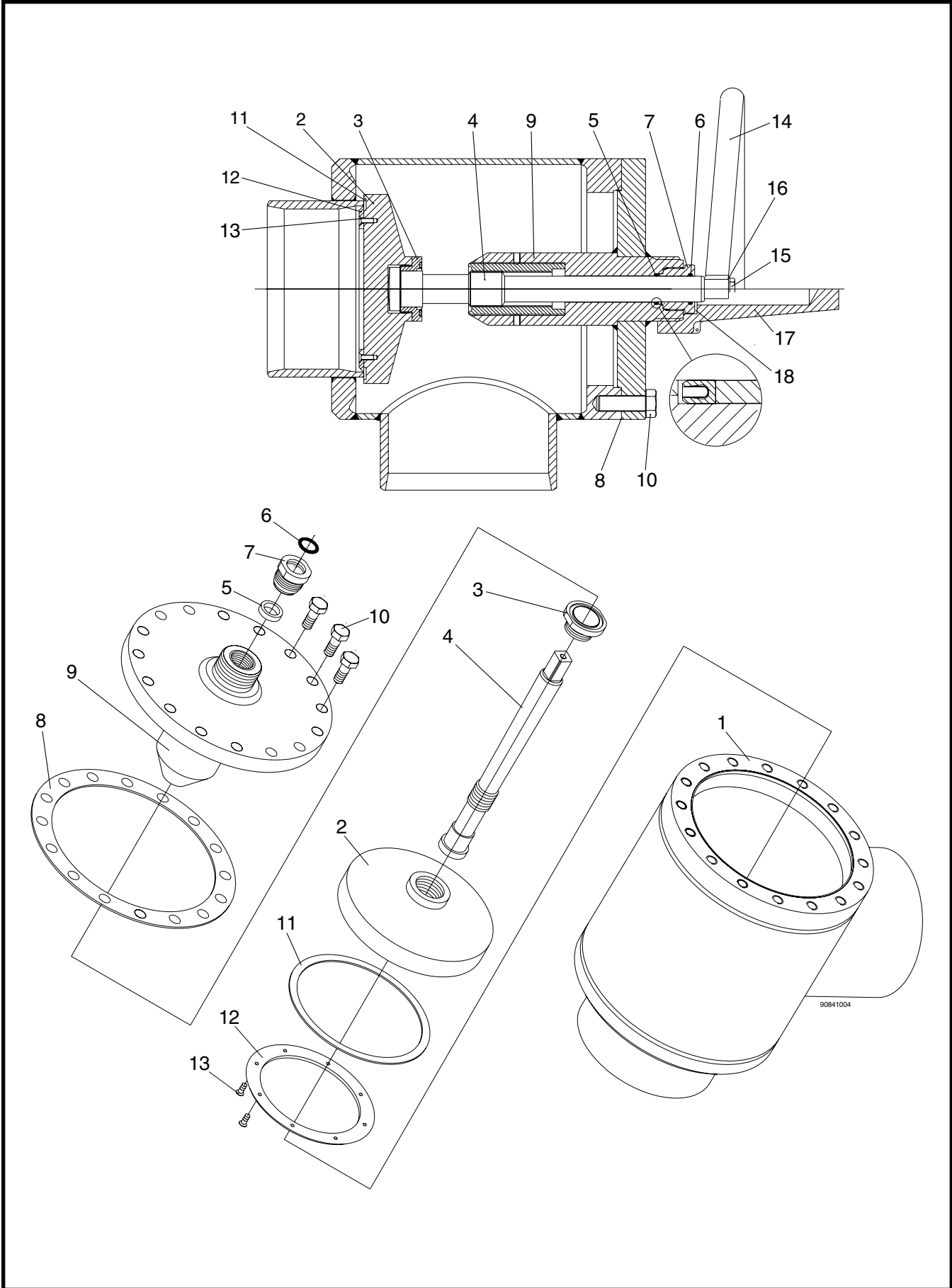

FIG. & INDEX	ITEM NUMBER	DESCRIPTION	QTY.	REV.	P & I REF.
22—	581C0157G01	8" Discharge Stop/Check Valve, R-22 (Gram/Frick)	Ref.	A	
	581C0157G02	8" Discharge Stop/Check Valve, R-717 (Gram/Frick)	Ref.	A	
	950A0145G01	8" Stop Valve, R-22 (Gram)	1	D	
	950A0145G02	8" Stop Valve, R-717 (Gram)	1	D	
	950A0147G01	10" Stop Valve, R-22 (Gram)*	1	D	
	950A0147G02	10" Stop Valve, R-717 (Gram)*	1	D	
—1	NA	Body, Stop Valve	Ref.		
—2	724000641GR	Cone, 8"		1	
	724000643GR	Cone, 10"	1		
—3	724000374GR	Nut, 8"	1		
	724000494GR	Nut, 10"	1		
—4	724000599GR	Spindle, 8"	1		
	724000600GR	Spindle, 10"	1		
—5	550940247GR	U-Sleeve, 8"	1		
	550940253GR	U-Sleeve, 10"	1		
—6	550840109GR	O-Ring, 8"	1		
	550840113GR	O-Ring, 10"	1		
—7	724000552GR	Screw, Packing, 8"	1		
	724000553GR	Screw, Packing, 10"	1		
—8	724000375GR	Gasket, 8"	1		
	724000495GR	Gasket, 10"	1		
—9	724000550GR	Cover, 8"	1		
	724000551GR	Cover, 10"	1		
—10	420098283GR	Screw, Allen Head, SS, M20 x 60	A/R		
—11	724000620GR	Seat, 8"	1		
	724000621GR	Seat, 10"	1		
—12	724000642GR	Plate, 8"	1		
	724000644GR	Plate, 10"	1		
—13	420801048GR	Screw, Allen Head, M6 x 16	A/R		
—14	480012400GR	Handwheel, 8"	1		
	480012500GR	Handwheel, 10"	1		
—15	420092241GR	Screw, M16 x 30	1		
—16	421642109GR	Disk	1		
—17	724003618GR	Cap	1		
—18	724003668GR	Seal	1		

Note: For 8" Check Valve parts see Figure 20.  
Not Shown: 581C0165G01, 8" Discharge Stop/Check Valve, with 82413535809 Gram Angle Valve HW.581C0165G02, 8" Discharge Stop/Check Valve, with 82413536809 Gram Angle Valve SC.  
\* The 10" Stop Valve is used with a 956A0016H08 Check Valve. There is no assembly number for a 10" Stop/Check Valve.

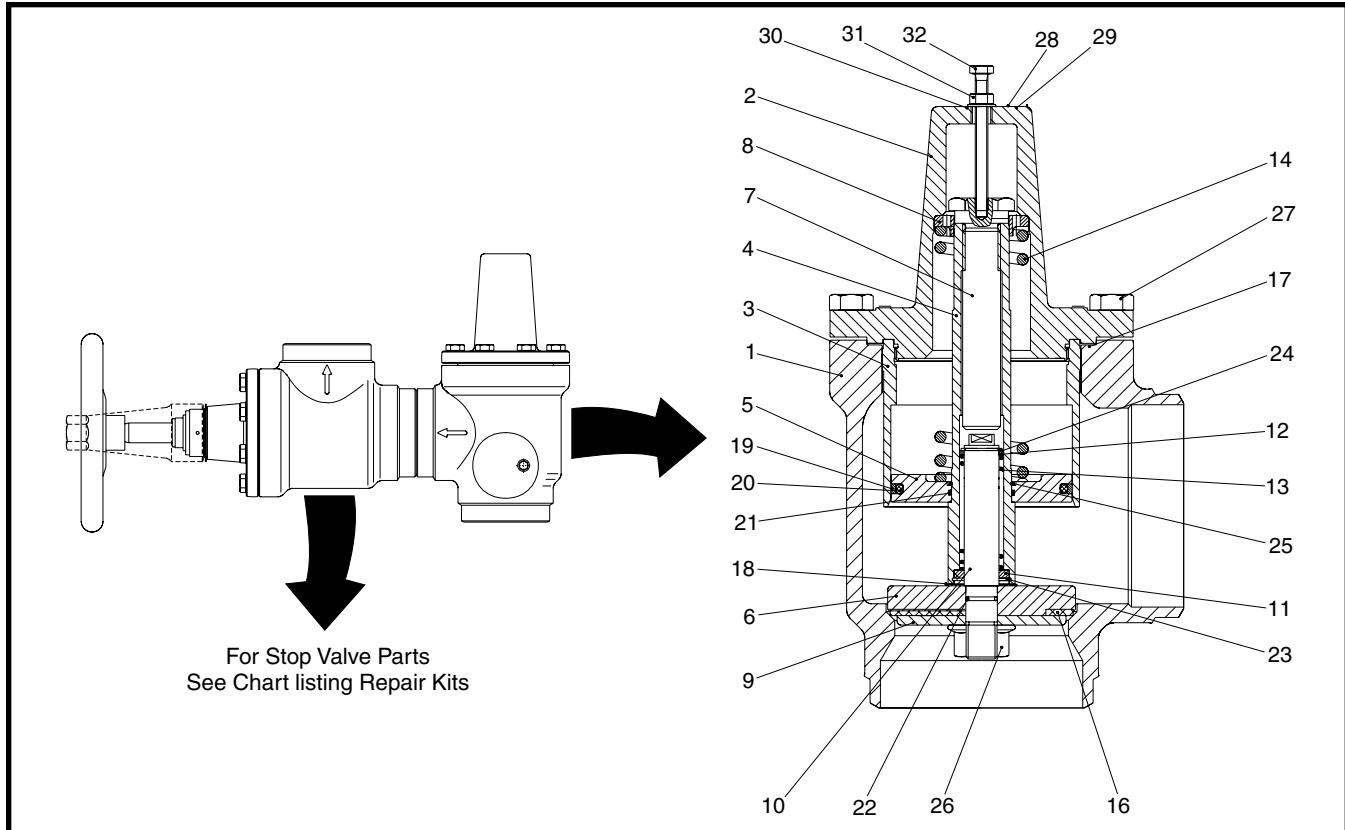

Figure 23. Discharge Stop/Check Valve, Current (Danfoss).

Figure 23. STOP VALVE ONLY

VALVE	DESCR,	SIZE	COMPLETE SPARES KIT <sup>(1)</sup>	PACKING GLAND KIT <sup>(2)</sup>	CONE KIT <sup>(3)</sup>	HW/SC KIT <sup>(4)</sup>	CAP & BONNET KIT <sup>(5)</sup>
950A0240H08	BW - HW	3	950A0240H25	950A0240H34	950A0240H45	950A0240H54	N/A
950A0240H09	BW - HW	4	950A0240H26	950A0240H34	950A0240H46	950A0240H55	N/A
950A0240H10	BW - HW	5	950A0240H27	950A0240H35	950A0240H47	950A0240H56	N/A
950A0240H11	BW - HW	6	950A0240H28	950A0240H35	950A0240H48	950A0240H56	N/A
950A0240H12	BW - HW	8	950A0240H29	650A0240H36	950A0240H49	950A0240H57	N/A
950A0241H08	BW - SC	3	950A0240H25	950A0240H34	950A0240H45	950A0241H63	950A0241H55
950A0241H09	BW - SC	4	950A0240H26	950A0240H34	950A0240H46	950A0241H63	950A0241H56
950A0241H10	BW - SC	5	950A0240H27	950A0240H35	950A0240H47	950A0241H64	950A0241H57
950A0241H11	BW - SC	6	950A0240H28	950A0240H35	950A0240H48	950A0241H64	950A0241H58
950A0241H12	BW - SC	8	950A0240H29	650A0240H36	950A0240H49	950A0241H65	950A0241H59

1. Consists of Cone & Cone Seal, Set Screw, Steel Balls, Packing Gland, Housing/Bonnet O-ring, Cap Gasket, Soft Backset (less stem).
2. Consists of Packing Gland, O-rings, and Wear Ring.
3. Consists of Cone Complete incl. Steel Balls & Set Screw, O-ring for Housing/Bonnet,
4. Consists of Handwheel, Washer, and Nut/Screw (Nut/Screw numbers are: 4" 950A0240H61/950A0240H64, 5-6" 950A0240H62/950A0240H65, 8" 950A0240H63/950A0240H66. Seal Cap Kit consists of Seal Cap and Gasket.
5. Consists of Seal Cap Gasket, O-ring for Housing/Bonnet, and Back Seat.

Figure 23. CHECK VALVE ONLY (See Index next page)

VALVE	APPLICATION	SIZE	BONNET GASKET	SEAL KIT	14.5 PSI SPRING KIT	29 PSI SPRING KIT
956A0044H01	HIGH STAGE	3	956A0044H11	956A0044H12	956A0044H13	956A0044H14
956A0044H02	BOOSTER	3	956A0044H11	956A0044H12	956A0044H13	956A0044H14
956A0045H01	HIGH STAGE	4	956A0045H11	956A0045H12	956A0045H13	956A0045H14
956A0045H02	BOOSTER	4	956A0045H11	956A0045H12	956A0045H13	956A0045H14
956A0046H01	HIGH STAGE	5	956A0046H11	956A0046H12	956A0046H13	956A0046H14
956A0046H02	BOOSTER	5	956A0046H11	956A0046H12	956A0046H13	956A0046H14
956A0047H01	HIGH STAGE	6	956A0047H11	956A0047H12	956A0047H13	956A0047H14
956A0047H02	BOOSTER	6	956A0047H11	956A0047H12	956A0047H13	956A0047H14
956A0048H01	HIGH STAGE	8	956A0048H11	956A0048H12	956A0048H13	956A0048H14
956A0048H02	BOOSTER	8	956A0048H11	956A0048H12	956A0048H13	956A0048H14

FIG. & INDEX	ITEM NUMBER	DESCRIPTION	QTY.	REV.	P & I REF.
23—	—	<b>Discharge Stop Check Valve Assembly (See Chart below)</b>	Ref.		
	—	<b>Stop Valve (See Chart previous page)</b>	Ref.		
	—	<b>Check Valve (See Chart previous page)</b>	Ref.		
—1	—	Housing	1		
—2	—	Bonnet	1		
—3	—	Piston Cylinder	1		
—4	—	Piston Rod	1		
—5	—	Piston	1		
—6	—	Cone	1		
—7	—	Spring Screw	1		
—8	—	Spring Bushing	1		
—9	—	Cone Plate	1		
—10	—	Cone Rod	1		
—11	—	Rear Bushing	1		
—12	—	Front Bushing	1		
—13	—	Spring	1		
—14	Spring Kit*	Spring	1		
—15	—	Plug (not shown)	1		
—16	Seal Kit*	Teflon Ring	1		
—17	Seal Kit*	Bonnet Gasket	1		
—18	Seal Kit*	Nylon Washer	1		
—19	Seal Kit*	Glyde Ring	1		
—20	Seal Kit*	O-Ring	1		
—21	Seal Kit*	O-Ring	1		
—22	Seal Kit*	O-Ring	1		
—23	—	Spring Ring	1		
—24	—	Spring Ring	1		
—25	—	Spring Ring	1		
—26	—	Nut	1		
—27	—	Set Screw	A/R		
—28	Spring Kit*	Marking Plate	1		
—29	Spring Kit*	Rivet	1		
—30	—	Washer	1		
—31	—	Nut	1		
—32	—	Screw	1		

\* See Check Valve Chart, previous page.

<b>Figure 23. DISCHARGE STOP-CHECK VALVE ASSEMBLY</b>				
ASSEMBLY	APPLICATION	SIZE	STOP VALVE	CHECK VALVE
582C0029G01	HIGH STAGE HW	3	950A0240H08	956A0044H01
582C0029G02	HIGH STAGE SC	3	950A0241H08	956A0044H01
582C0029G03	BOOSTER HW	3	950A0240H08	956A0044H02
582C0029G04	BOOSTER SC	3	950A0241H08	956A0044H02
582C0030G01	HIGH STAGE HW	4	950A0240H09	956A0045H01
582C0030G02	HIGH STAGE SC	4	950A0241H09	956A0045H01
582C0030G03	BOOSTER HW	4	950A0240H09	956A0045H02
582C0030G04	BOOSTER SC	4	950A0241H09	956A0045H02
582C0031G01	HIGH STAGE HW	5	950A0240H10	956A0046H01
582C0031G02	HIGH STAGE SC	5	950A0241H10	956A0046H01
582C0031G03	BOOSTER HW	5	950A0240H10	956A0046H02
582C0031G04	BOOSTER SC	5	950A0241H10	956A0046H02
582C0032G01	HIGH STAGE HW	6	950A0240H11	956A0047H01
582C0032G02	HIGH STAGE SC	6	950A0241H11	956A0047H01
582C0032G03	BOOSTER HW	6	950A0240H11	956A0047H02
582C0032G04	BOOSTER SC	6	950A0241H11	956A0047H02
582C0033G01	HIGH STAGE HW	8	950A0240H12	956A0048H01
582C0033G02	HIGH STAGE SC	8	950A0241H12	956A0048H01
582C0033G03	BOOSTER HW	8	950A0240H12	956A0048H02
582C0033G04	BOOSTER SC	8	950A0241H12	956A0048H02

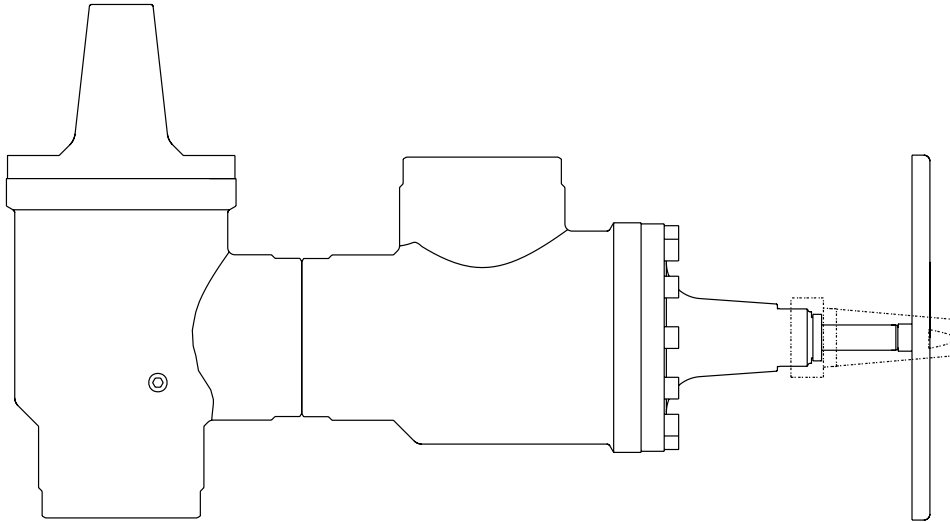

GRAM DISCHARGE STOP-CHECK ASSEMBLY				
ASSEMBLY	APPLICATION	SIZE	STOP VALVE	CHECK VALVE
581C0167G01	HIGH STAGE HW	3	82409535309	82452022300
581C0167G02	HIGH STAGE SC	3	82409536309	82452022300
581C0167G03	BOOSTER HW	3	82409535309	82452023300
581C0167G04	BOOSTER SC	3	82409536309	82452023300
581C0158G01	HIGH STAGE HW	4	82410535409	82452022400
581C0158G02	HIGH STAGE SC	4	82410536409	82452022400
581C0158G03	BOOSTER HW	4	82410535409	82452023400
581C0158G04	BOOSTER SC	4	82410536409	82452023400
581C0159G01	HIGH STAGE HW	5	82411535509	82452022500
581C0159G02	HIGH STAGE SC	5	82411536509	82452022500
581C0159G03	BOOSTER HW	5	82411535509	82452023500
581C0159G04	BOOSTER SC	5	82411536509	82452023500
581C0160G01	HIGH STAGE HW	6	82412535609	82452022600
581C0160G02	HIGH STAGE SC	6	82412536609	82452022600
581C0160G03	BOOSTER HW	6	82412535609	82452023600
581C0160G04	BOOSTER SC	6	82412536609	82452023600
581C0168G01	HIGH STAGE HW	8	82413535809	82452022800
581C0168G02	HIGH STAGE SC	8	82413536809	82452022800
581C0168G03	BOOSTER HW	8	82413535809	82452023800
581C0168G04	BOOSTER SC	8	82413536809	82452023800

Figure 24. Discharge Stop/Check Valve (Gram).

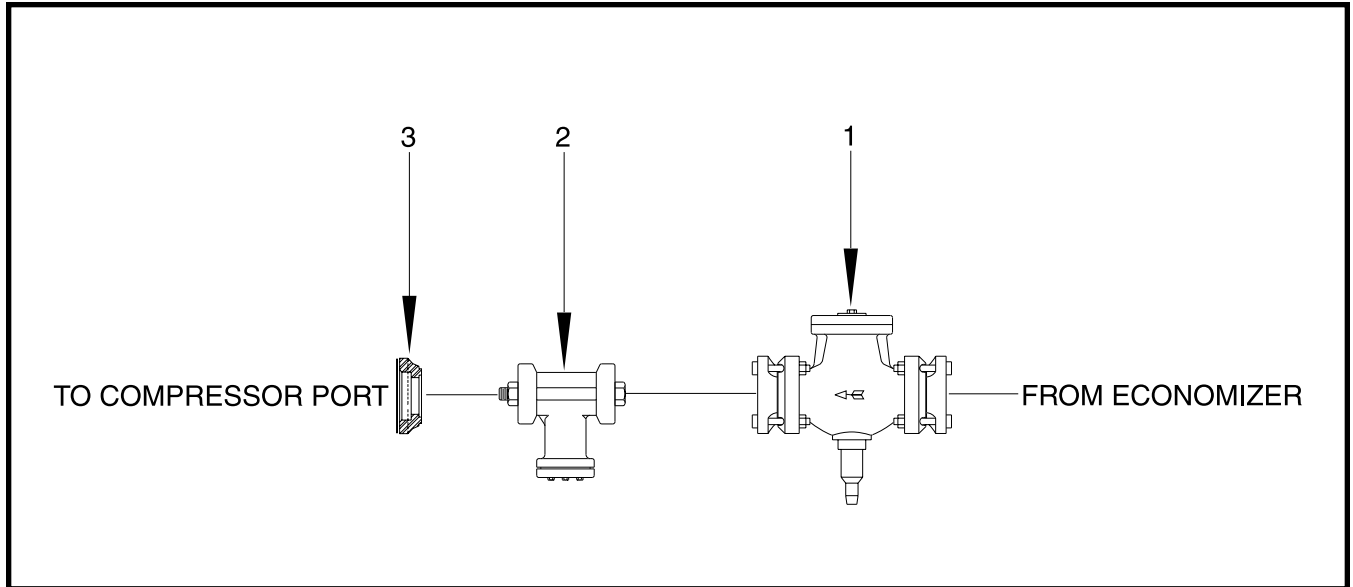

**Figure 25. Economizer Kit.**

FIG. & INDEX	ITEM NUMBER	DESCRIPTION	QTY.	REV.	P & I REF.
25—	535B0021 535M0001Gxx	Economizer Port Location & Kit Details Economizer Kit, RWB II 60—676	Ref. Ref.	D	
—1	956A0025H23	Valve, Check, 1-1/2", R-717 & R-22	1		
	959A0057H05	Gasket, Flange	2		
	956A0025H24	Valve, Check, 2", R-717 & R-22	1		
	959A0057H07	Gasket, Flange	2		
	956A0025H25	Valve, Check, 3", R-717 & R-22	1		
	959A0057H18	Gasket, Flange	2		
	956A0025H22	Valve, Check, 1-1/4", R-22	1		
	959A0057H04	Gasket, Flange	2		
	956A0025H26	Valve, Check, 4", R-22	1		
	959A0057H09	Gasket, Flange	2		
—2	950A0001H05	Strainer, 1-1/4", R-717 & R-22	1		
	950A0001H24	Kit, Screen (consisting of screen, spring & gasket)	1		
	950A0001H33	Gasket, Flange	2		
	950A0001H06	Strainer, 2", R-717 & R-22	1		
	950A0001H25	Kit, Screen (consisting of screen, spring & gasket)	1		
	950A0001H34	Gasket, Flange	2		
	950A0001H09	Strainer, 3", R-717 & R-22	1		
	950A0001H28	Kit, Screen (consisting of screen, spring & gasket)	1		
	950A0001H36	Gasket, Flange	2		
	950A0001H11	Strainer, 4", R-22	1		
	950A0001H29	Kit, Screen (consisting of screen, spring & gasket)	1		
	950A0001H37	Gasket, Flange	2		
—3	944A0358H01	Flange, SW, 1-1/4", 60 & 76	1		
	959A0057H04	Gasket, Flange, 60 & 76	1		
	944A0358H02	Flange, SW, 1-1/2", 100—222	1		
	959A0057H05	Gasket, Flange, 100—222	1		
	944A0358H03	Flange, SW, 2", 316 & 399	1		
	959A0057H07	Gasket, Flange, 316 & 399	1		
	944A0358H05	Flange, SW, 3", 480—676	1		
	959A0057H18	Gasket, Flange, 480—676	1		

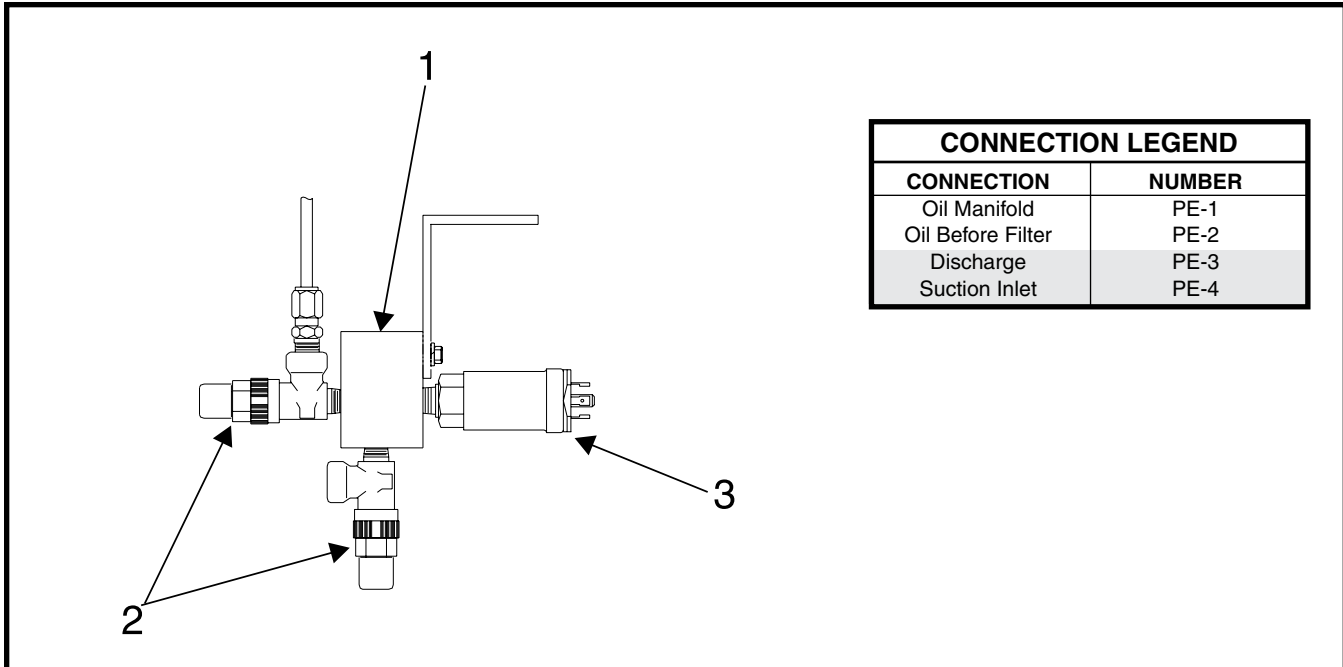
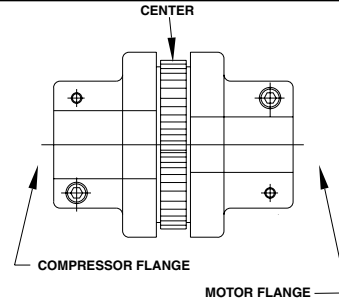

Figure 26. Transducer Manifold Assembly.

FIG. & INDEX	ITEM NUMBER	DESCRIPTION	QTY.	REV.	P & I REF.
26—	720M0017G01	Transducer Manifold and Piping	Ref.		
	535D0305G01	Assembly, Transducer Manifold	Ref.	A	
—1	535C0348H01	Manifold, Transducer, Aluminum	1		
—2	957A0003H01	Valve, Angle, Seal Cap, 1/4" NPT	7		
—3	913A0146H05	Transducer, Pressure, 0-300 PSIA (Plus Micro)*	1		PE1-3
	913A0146H02	Transducer, Pressure, 0-500 PSIA (Quantum)*	3		PE1-3
	913A0146H04	Transducer, Pressure, 0-100 PSIA (Plus Micro)*	1		PE-4
	913A0146H01	Transducer, Pressure, 0-200 PSIA (Quantum)*	1		PE-4
	913A0146H05	Transducer, Pressure, 0-300 PSIA (Plus Micro)*	1		PE-4
* Plus 649D4864H01 Replacement Cable for older units without DIN connector.					



MODEL	SIZE	COMPRESSOR FLANGE		CENTER	MOTOR FLANGE	
		PART NO.	BORE		PART NO.	BORE
60-76	8C	930A0093H29	1.75"	930A0093H01	930A0093H03	1.875"
60-76	8C	930A0093H29	1.75	930A0093H01	930A0093H04	2.125
60-76	8C	930A0093H29	1.75	930A0093H01	930A0093H46	1.625
60-76	9C	930A0093H30	1.75	930A0093H05	930A0093H07	1.875
60-76	9C	930A0093H30	1.75	930A0093H05	930A0093H08	2.125
60-76	9C	930A0093H30	1.75	930A0093H05	930A0093H09	2.375
60-76	9C	930A0093H30	1.75	930A0093H05	930A0093H94	2.362
60-76	10C	930A0093H38	1.75	930A0093H11	930A0093H23	2.875
60-76	10C	930A0093H38	1.75	930A0093H11	930A0093H52	2.375
100-134	8C	930A0093H36	2.25	930A0093H01	930A0093H03	1.875
100-134	8C	930A0093H36	2.25	930A0093H01	930A0093H04	2.125
100-134	8C	930A0093H36	2.25	930A0093H01	930A0093H53	2.375
100-134	9C	930A0093H31	2.25	930A0093H05	930A0093H07	1.875
100-134	9C	930A0093H31	2.25	930A0093H05	930A0093H08	2.125
100-134	9C	930A0093H31	2.25	930A0093H05	930A0093H09	2.375
100-134	9C	930A0093H31	2.25	930A0093H05	930A0093H91	2.559
100-134	10C	930A0093H32	2.25	930A0093H11	930A0093H13	1.875
100-134	10C	930A0093H32	2.25	930A0093H11	930A0093H14	2.125
100-134	10C	930A0093H32	2.25	930A0093H11	930A0093H15	2.375
100-134	10C	930A0093H32	2.25	930A0093H11	930A0093H23	2.875
100-134	10C	930A0093H32	2.25	930A0093H11	930A0093H41	2.625
100-134	10C	930A0093H32	2.25	930A0093H11	930A0093H89	2.165
100-134	11C	930A0093H49	2.25	930A0093H17	930A0093H44	3.375
100-134	11C	930A0093H49	2.25	930A0093H17	930A0093H19	2.375
100-134	11C	930A0093H49	2.25	930A0093H17	930A0093H79	2.625
100-134	11C	930A0093H49	2.25	930A0093H17	930A0093H87	2.625
177-222	9C	930A0093H40	2.50	930A0093H05	930A0093H07	1.875
177-222	9C	930A0093H40	2.50	930A0093H05	930A0093H08	2.125
177-222	9C	930A0093H40	2.50	930A0093H05	930A0093H09	2.375
177-222	10C	930A0093H34	2.50	930A0093H11	930A0093H15	2.375
177-222	10C	930A0093H34	2.50	930A0093H11	930A0093H23	2.875
177-222	10C	930A0093H34	2.50	930A0093H11	930A0093H55	2.165
177-222	10C	930A0093H34	2.50	930A0093H11	930A0093H56	2.750
177-222	11C	930A0093H35	2.50	930A0093H17	930A0093H47	2.875
177-222	11C	930A0093H35	2.50	930A0093H17	930A0093H33	2.625
177-222	11C	930A0093H35	2.50	930A0093H17	930A0093H19	2.375
177-222	11C	930A0093H35	2.50	930A0093H17	930A0093H50	3.000
177-222	11C	930A0093H35	2.50	930A0093H17	930A0093H44	3.375
177-222	11C	930A0093H35	2.50	930A0093H17	930A0093H76	2.362
177-222	11C	930A0093H35	2.50	930A0093H17	930A0093H78	2.559
177-222	11C	930A0093H35	2.50	930A0093H17	930A0093H86	2.756
316-399	11C	930A0093H45	3.25	930A0093H17	930A0093H19	2.375
316-399	11C	930A0093H45	3.25	930A0093H17	930A0093H47	2.875
316-399	11C	930A0093H45	3.25	930A0093H17	930A0093H57	2.756
316-399	11C	930A0093H45	3.25	930A0093H17	930A0093H70	2.165
316-399	11C	930A0093H45	3.25	930A0093H17	930A0093H71	3.375
316-399	11C	930A0093H45	3.25	930A0093H17	930A0093H33	2.625
316-399	11C	930A0093H45	3.25	930A0093H17	930A0093H79	2.625
316-399	11C	930A0093H45	3.25	930A0093H17	930A0093H78	2.559

**Figure 27. Drive Coupling, Models 60—399**

**RWB II ROTARY SCREW COMPRESSOR UNIT  
SERVICE PARTS LIST**

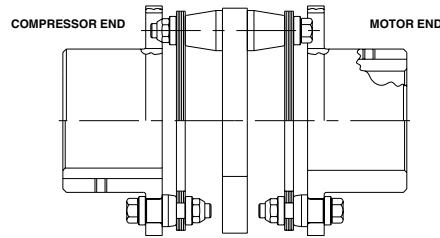

MODEL	SIZE	COMPRESSOR BORE	MOTOR BORE	ASSEMBLY NO.
177-270	226	2.50"	1.500"	535C0342H01
177-270	226	2.50	1.625	535C0342H02
177-270	226	2.50	1.750	535C0342H03
177-270	226	2.50	1.875	535C0342H04
177-270	226	2.50	2.000	535C0342H05
177-270	226	2.50	2.125	535C0342H06
177-270	226	2.50	2.250	535C0342H07
177-270	226	2.50	2.375	535C0342H08
177-270	226	2.50	2.500	535C0342H09
177-270	226	2.50	2.625	535C0342H10
177-270	263	2.50	1.500	535C0342H11
177-270	263	2.50	1.625	535C0342H12
177-270	263	2.50	1.750	535C0342H13
177-270	263	2.50	1.875	535C0342H14
177-270	263	2.50	2.000	535C0342H15
177-270	263	2.50	2.125	535C0342H16
177-270	263	2.50	2.250	535C0342H17
177-270	263	2.50	2.375	535C0342H18
177-270	263	2.50	2.500	535C0342H19
177-270	263	2.50	2.625	535C0342H20
177-270	263	2.50	2.750	535C0342H21
177-270	263	2.50	2.875	535C0342H22
177-270	263	2.50	3.000	535C0342H23
177-270	301	2.50	1.500	535C0342H24
177-270	301	2.50	1.625	535C0342H25
177-270	301	2.50	1.750	535C0342H26
177-270	301	2.50	1.875	535C0342H27
177-270	301	2.50	2.000	535C0342H28
177-270	301	2.50	2.125	535C0342H29
177-270	301	2.50	2.250	535C0342H30
177-270	301	2.50	2.375	535C0342H31
177-270	301	2.50	2.500	535C0342H32
177-270	301	2.50	2.625	535C0342H33
177-270	301	2.50	2.750	535C0342H34
177-270	301	2.50	2.875	535C0342H35
177-270	301	2.50	3.000	535C0342H36
177-270	301	2.50	3.125	535C0342H37
177-270	301	2.50	3.250	535C0342H38
177-270	301	2.50	3.375	535C0342H39
177-270	301	2.50	3.500	535C0342H40
177-270	351	2.50	1.500	535C0342H41
177-270	351	2.50	1.625	535C0342H42
177-270	351	2.50	1.750	535C0342H43
177-270	351	2.50	1.875	535C0342H44
177-270	351	2.50	2.000	535C0342H45
177-270	351	2.50	2.125	535C0342H46
177-270	351	2.50	2.250	535C0342H47
177-270	351	2.50	2.375	535C0342H48
177-270	351	2.50	2.500	535C0342H49
177-270	351	2.50	2.625	535C0342H50
177-270	351	2.50	2.750	535C0342H51
177-270	351	2.50	2.875	535C0342H52

**Figure 28. Drive Coupling, Models 177—270**

**COUPLING ASSEMBLIES - Figure 27, Continued.**

MODEL	SIZE	COMPRESSOR BORE	MOTOR BORE	ASSEMBLY NO.
177-270	351	2.50"	3.000"	535C0342H53
177-270	351	2.50	3.125	535C0342H54
177-270	351	2.50	3.250	535C0342H55
177-270	351	2.50	3.375	535C0342H56
177-270	351	2.50	3.500	535C0342H57
177-270	351	2.50	3.625	535C0342H58
177-270	351	2.50	3.750	535C0342H59
177-270	351	2.50	3.875	535C0342H60
177-270	351	2.50	4.000	535C0342H61

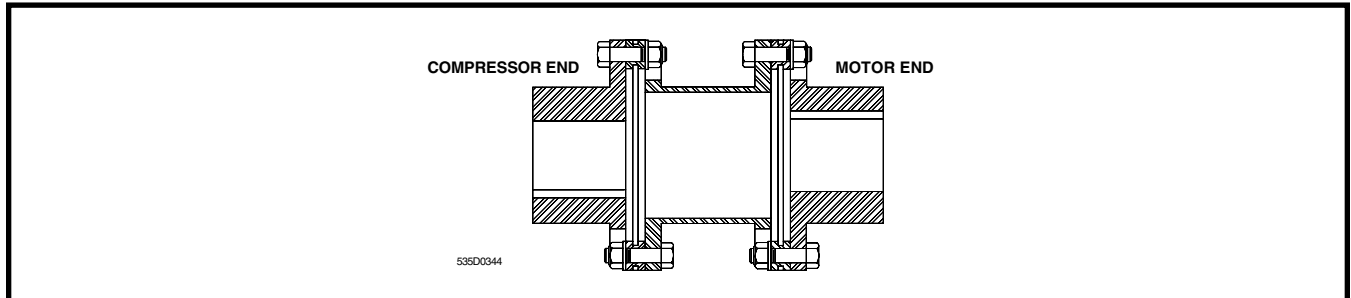

BORE		ASSEMBLY NUMBERS				
MOTOR	COMPRESSOR	SIZE 250	SIZE 320	SIZE 400	SIZE 500	SIZE 630
1.875"	3.250"	535D0344H01	535D0344H13	—	—	—
2.000	3.250	535D0344H02	535D0344H14	535D0344H26	535D0344H40	—
2.125	3.250	535D0344H03	535D0344H15	535D0344H27	535D0344H41	—
2.250	3.250	535D0344H04	535D0344H16	535D0344H28	535D0344H42	—
2.375	3.250	535D0344H05	535D0344H17	535D0344H29	535D0344H43	—
2.500	3.250	535D0344H06	535D0344H18	535D0344H30	535D0344H44	—
2.625	3.250	535D0344H07	535D0344H19	535D0344H31	535D0344H45	—
2.750	3.250	535D0344H08	535D0344H20	535D0344H32	535D0344H46	—
2.875	3.250	535D0344H09	535D0344H21	535D0344H33	535D0344H47	—
3.000	3.250	535D0344H10	535D0344H22	535D0344H34	535D0344H48	—
3.125	3.250	535D0344H11	535D0344H23	535D0344H35	535D0344H49	—
3.250	3.250	535D0344H12	535D0344H24	535D0344H36	535D0344H50	—
3.375	3.250	—	535D0344H25	535D0344H37	535D0344H51	—
3.500	3.250	—	—	535D0344H38	535D0344H52	—
3.625	3.250	—	—	535D0344H39	535D0344H53	—
3.750	3.250	—	—	—	535D0344H54	—
3.875	3.250	—	—	—	535D0344H55	—
2.000	3.750	—	—	—	535D0344H56	—
2.125	3.750	—	—	—	535D0344H57	—
2.250	3.750	—	—	—	535D0344H58	—
2.375	3.750	—	—	—	535D0344H59	535D0344H72
2.500	3.750	—	—	—	535D0344H60	535D0344H73
2.625	3.750	—	—	—	535D0344H61	535D0344H74
2.750	3.750	—	—	—	535D0344H62	535D0344H75
2.875	3.750	—	—	—	535D0344H63	535D0344H76
3.000	3.750	—	—	—	535D0344H64	535D0344H77
3.125	3.750	—	—	—	535D0344H65	535D0344H78
3.250	3.750	—	—	—	535D0344H66	535D0344H79
3.375	3.750	—	—	—	535D0344H67	535D0344H80
3.500	3.750	—	—	—	535D0344H68	535D0344H81
3.625	3.750	—	—	—	535D0344H69	535D0344H82
3.750	3.750	—	—	—	535D0344H70	535D0344H83
3.875	3.750	—	—	—	535D0344H71	535D0344H84
4.000	3.750	—	—	—	—	535D0344H85
4.125	3.750	—	—	—	—	535D0344H86

Note: Size 250, 320 and 400 used on Models 316 and 399. Size 500 and 630 used on Models 496 and 676.

**Figure 29. Drive Coupling, Models 316—676.**

**RWB II ROTARY SCREW COMPRESSOR UNIT  
SERVICE PARTS LIST**

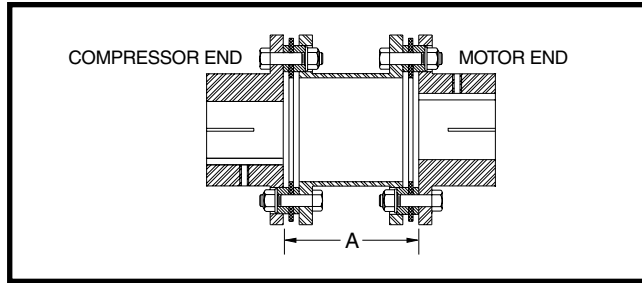

**Figure 30. Drive Coupling, Models 496—856.  
COUPLING ASSEMBLIES-Figure 30.**

BORE		ASSEMBLY NUMBERS				
MOTOR	COMPRESSOR	SIZE BP48	SIZE BP53	SIZE BP58*	SIZE BP58**	SIZE BP63
2.375"	2.500"	535D0503H01	535D0503H25	—	—	—
2.500	2.500	535D0503H02	535D0503H26	—	—	—
2.625	2.500	535D0503H03	535D0503H27	—	—	—
2.750	2.500	535D0503H04	535D0503H28	—	—	—
2.875	2.500	535D0503H05	535D0503H29	—	—	—
3.000	2.500	535D0503H06	535D0503H30	—	—	—
3.125	2.500	535D0503H07	535D0503H31	—	—	—
3.250	2.500	535D0503H08	535D0503H32	—	—	—
3.375	2.500	535D0503H09	535D0503H33	—	—	—
3.500	2.500	535D0503H10	535D0503H34	—	—	—
3.625	2.500	535D0503H11	535D0503H35	—	—	—
3.750	2.500	535D0503H12	535D0503H36	—	—	—
2.375	3.250	535D0503H13	535D0503H37	—	—	—
2.500	3.250	535D0503H14	535D0503H38	—	—	—
2.625	3.250	535D0503H15	535D0503H39	—	—	—
2.750	3.250	535D0503H16	535D0503H40	—	—	—
2.875	3.250	535D0503H17	535D0503H41	—	—	—
3.000	3.250	535D0503H18	535D0503H42	—	—	—
3.125	3.250	535D0503H19	535D0503H43	—	—	—
3.250	3.250	535D0503H20	535D0503H44	—	—	—
3.375	3.250	535D0503H21	535D0503H45	—	—	—
3.500	3.250	535D0503H22	535D0503H46	—	—	—
3.625	3.250	535D0503H23	535D0503H47	—	—	—
3.750	3.250	535D0503H24	535D0503H48	—	—	—
2.375	3.250	—	—	535D0503H49	—	—
2.500	3.250	—	—	535D0503H50	—	—
2.625	3.250	—	—	535D0503H51	—	—
2.750	3.250	—	—	535D0503H52	—	—
2.875	3.250	—	—	535D0503H53	—	—
3.000	3.250	—	—	535D0503H54	—	—
3.125	3.250	—	—	535D0503H55	—	—
3.250	3.250	—	—	535D0503H56	—	—
3.375	3.250	—	—	535D0503H57	—	—
3.500	3.250	—	—	535D0503H58	—	—
3.625	3.250	—	—	535D0503H59	—	—
3.750	3.250	—	—	535D0503H60	—	—
3.875	3.250	—	—	535D0503H61	—	—
4.000	3.250	—	—	535D0503H62	—	—
4.125	3.250	—	—	535D0503H63	—	—
2.375	3.750	—	—	—	535D0503H64	—
2.500	3.750	—	—	—	535D0503H65	—
2.625	3.750	—	—	—	535D0503H66	—
2.750	3.750	—	—	—	535D0503H67	—
2.875	3.750	—	—	—	535D0503H68	535D0503H79
3.000	3.750	—	—	—	535D0503H69	535D0503H80
3.125	3.750	—	—	—	535D0503H70	535D0503H81
3.250	3.750	—	—	—	535D0503H71	535D0503H82

**COUPLING ASSEMBLIES-Figure 30, Continued.**

BORE		ASSEMBLY NUMBERS				
MOTOR	COMPRESSOR	SIZE BP48	SIZE BP53	SIZE BP58*	SIZE BP58**	SIZE BP63
3.375"	3.750"	—	—	—	535D0503H72	535D0503H83
3.500	3.750	—	—	—	535D0503H73	535D0503H84
3.625	3.750	—	—	—	535D0503H74	535D0503H85
3.750	3.750	—	—	—	535D0503H75	535D0503H86
3.875	3.750	—	—	—	535D0503H76	535D0503H87
4.000	3.750	—	—	—	535D0503H77	535D0503H88
4.125	3.750	—	—	—	535D0503H78	535D0503H89
4.250	3.750	—	—	—	—	535D0503H90
4.375	3.750	—	—	—	—	535D0503H91
4.500	3.750	—	—	—	—	535D0503H92
4.625	3.750	—	—	—	—	535D0503H93
4.750	3.750	—	—	—	—	535D0503H94
4.875	3.750	—	—	—	—	535D0503H95

\* A = 6.69"

\*\* A = 6.00"

**COMPRESSOR PORT LOCATION LEGEND**  
For Figures 31 —34

SB-2	INLET BEARING & BALANCE PISTON
SB-3	DISCHARGE BEARINGS & SEAL
SC-1	SLIDE VALVE - UNLOAD
SC-2	SLIDE VALVE - LOAD
SC-3	MOVEABLE SLIDE STOP
SC-4	MOVEABLE SLIDE STOP
SC-5	INLET PRESSURE
SC-6	DISCHARGE PRESSURE
SC-7	SEAL WEEPAGE
SC-8	CLOSED THREAD DRAIN CONNECTION
SC-9	INLET OIL DRAIN
SC-10	DISCHARGE BEARINGS PRELUBE (OPT)
SC-11	OIL DRAIN CONNECTION (OPT)
SC-12	DISCHARGE BEARING PRELUBE (OPT)
SC-13	OIL DRAIN CYLINDER
SE-1	ELECTRICAL CONNECTION
SE-2	ELECTRICAL CONNECTION
SL-1	LIQUID INJECTION LOW V <sub>i</sub>
SL-2	LIQUID INJECTION HIGH V <sub>i</sub>
SM-1	MAIN OIL INJECTION
SV-1	VAPOR INJECTION TONGUE & GROOVE
SD-1	COALESCER BLEED STR THD O-RING PORT

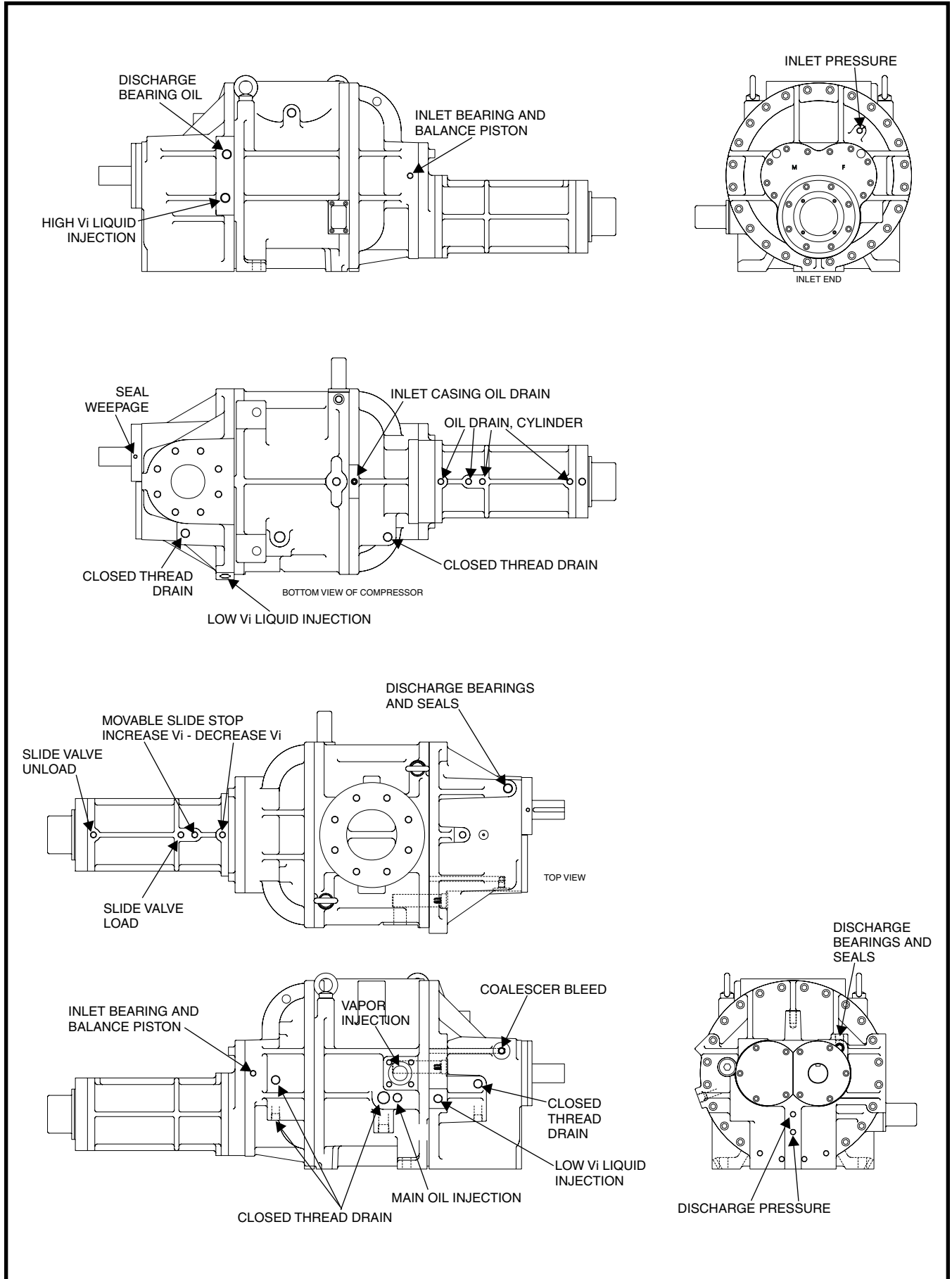

**Figure 31. 163/193mm Compressor Ports Locations**

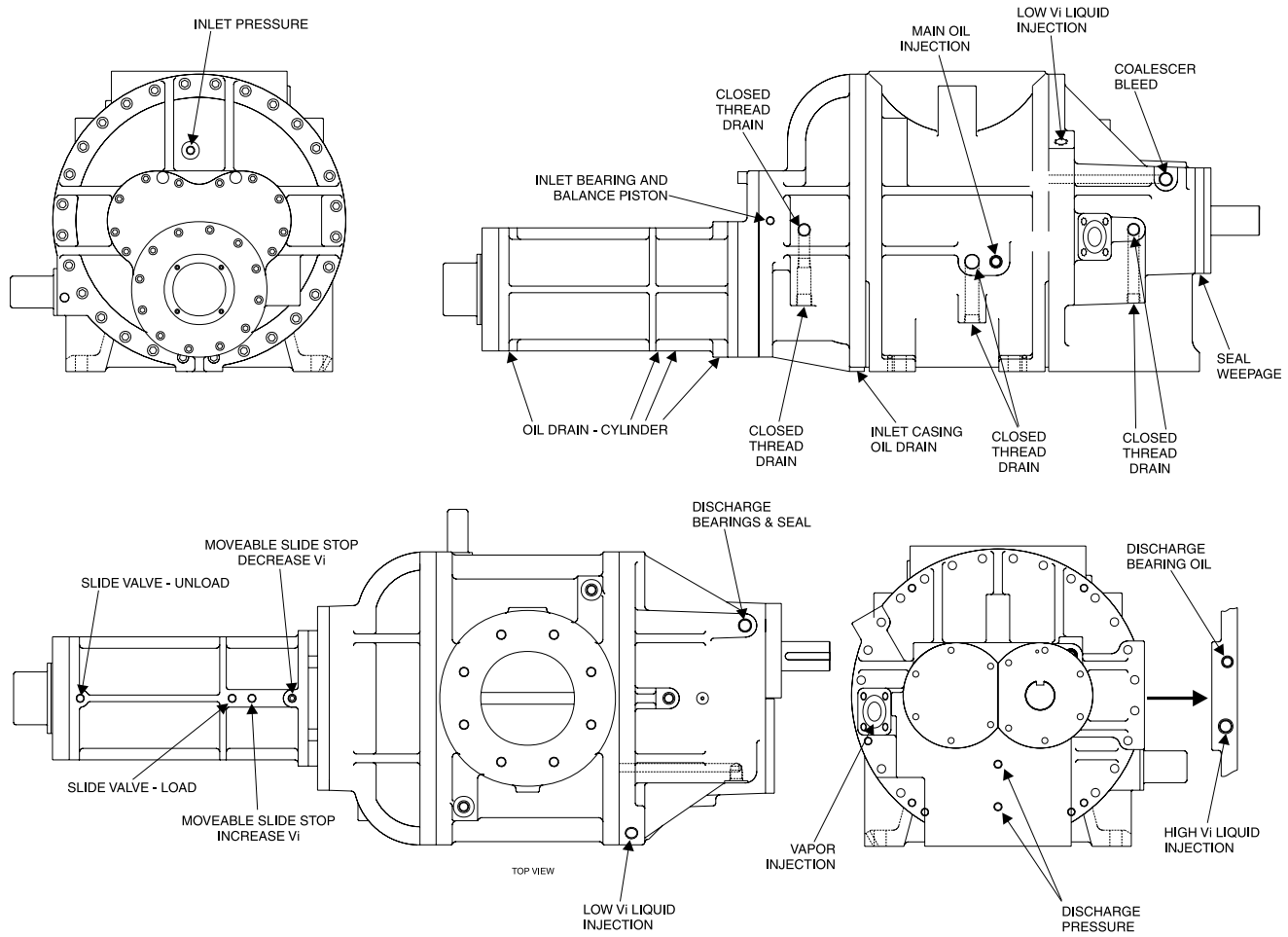
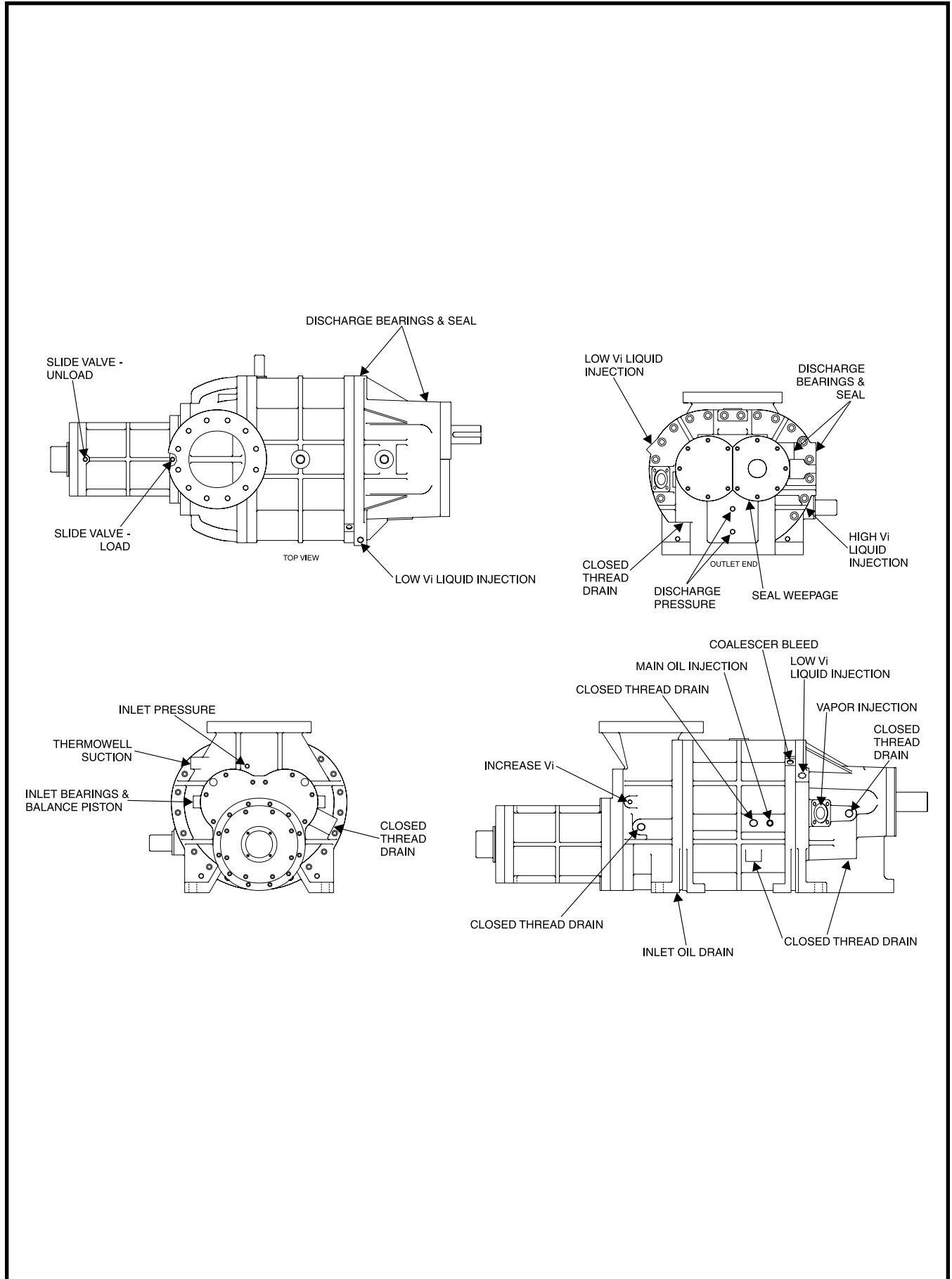

Figure 32. 233mm Compressor Ports Locations



**Figure 33. 283mm Compressor Ports Locations**

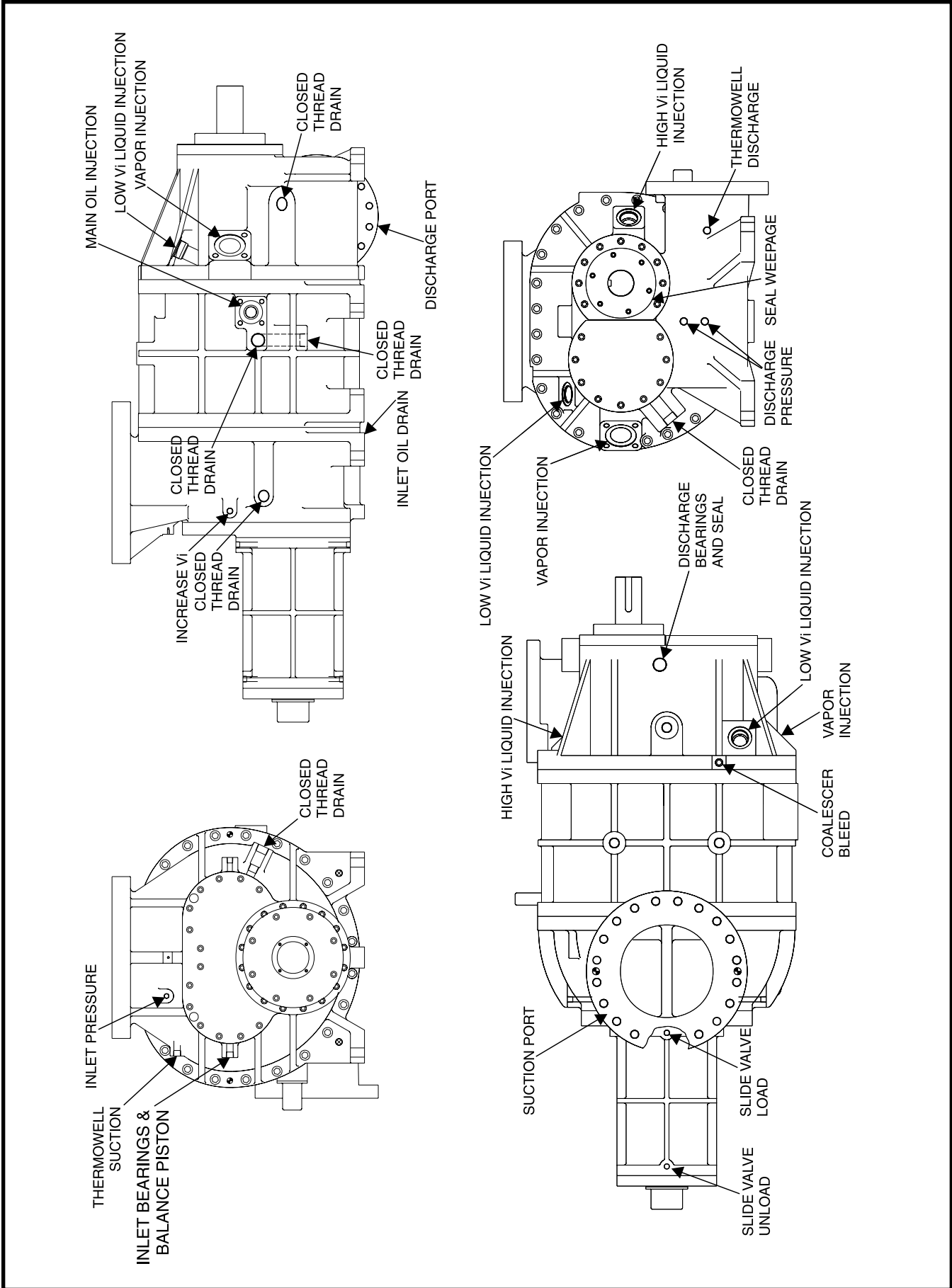

Figure 34. 355mm Compressor Ports Locations

<b>FRICK COMPRESSOR OILS</b>			
<b>Number</b>	<b>5 Gallon</b>	<b>55 Gallon</b>	<b>330 Gallon</b>
2A	111Q0550019	111Q0550020	333Q0001866
3	111Q0550001	111Q0550010	333Q0001861
4	—	111Q0550005	—
5	111Q0550008	111Q0550009	—
6	333Q0000940	333Q0000941	—
7	111Q0550024	111Q0550025	—
9	333Q0000850	333Q0000849	333Q0001862
9ST	333Q0001905	333Q0001904	—
10	333Q0000740	333Q0000739	—
11	333Q0000852	333Q0000851	333Q0001863
11ST	333Q0001907	333Q0001906	—
12	333Q0001141	333Q0001142	—
12B	333Q0001883	333Q0001884	—
13	333Q0001253	333Q0001254	—
14	333Q0001144	333Q0001145	—
18	—	333Q0001892	—
19	333Q0001899	333Q0001900	—
20	333Q0001902	333Q0001903	—
NG 1	—	333Q0001850	—
NG 2	—	333Q0001851	—
NG 3	—	333Q0001852	—

Oil Analysis Kit - 333Q0001853  
Tube of Motor Grease - 333Q0001860

<b>FRICK BLUE PAINT</b>	
<b>Size Each</b>	<b>Item Number</b>
1 PT.	993A0001H01*
1 GAL.	333Q0000404
2 GAL.	333Q0000724**

\* Spray Can

\*\* Matte finish epoxy paint. One gallon each of resin and cure that require mixing.

<b>FRICK FLANGE GASKETS</b>			
<b>GASKET NO.</b>	<b>FLANGE SIZE</b>	<b>ID</b>	<b>OD</b>
959A0057H01	1/4	29/32	1-11/32
959A0057H02	3/8 & 1/2	1-9/32	1-23/32
959A0057H03	3/4 & 1	1-21/32	2-3/32
959A0057H04	1-1/4	1-27/32	2-9/32
959A0057H05	1-1/2	2-1/8	2-3/4
959A0057H06	2-1/2	3	3-3/4
959A0057H07	2	2-1/2	3-1/4
959A0057H08	3-1/2	4-1/8	4-7/8
959A0057H09	4	4-3/4	5-1/2
959A0057H10	5	6-1/4	7
959A0057H11	6	7-3/8	8-1/8
959A0057H12	8	9-9/16	10-1/2
959A0057H13	10	11-7/8	12-15/16
959A0057H14	12	13-1/4	14-1/4
959A0057H15	14	14-3/4	16-1/32
959A0057H16	3/4	1-5/16	1-13/16
959A0057H18	3	3-5/8	4-3/8

**RWB II ROTARY SCREW COMPRESSOR UNIT  
SERVICE PARTS LIST**



<b>MISCELLANEOUS TUBING AND CONNECTORS</b>	
<b>ITEM NUMBER</b>	<b>DESCRIPTION</b>
111Q0350059	Connection, 1/2 ODF x 3/8" MPT
111Q0350659	Elbow, 1/2 ODT x 1/2" MPT
111Q0350713	Elbow, 1/2 ODT x 1/4" MPT
111Q0350714	Connection, Steel, 1/2 ODF x 1/4" MPT
111Q0350715	Connection, Steel, 1/2 ODF x 1/2" MPT
111Q0350955	Elbow, 1/2 ODT x 3/4" MPT
111Q0350956	Connection, Steel, 1/2 ODF x 3/4" MPT
111Q0350958	Elbow, Steel, 3/4 ODT x 3/4" MPT
111Q0350970	Connection, Steel, 3/4 ODF x 3/4" MPT
111Q0350989	Elbow, Steel, 1 ODT x 1" MPT
111Q0350990	Connection, Steel, 1 ODF x 1" MPT
111Q0351029	Elbow, 1-1/4 ODT x 1-1/4" MPT
111Q0351034	Connection, Steel, 3/4 ODF x 1/2" MPT
111Q0351038	Sleeve, Steel, 3/4" ODF
111Q0351040	Elbow, 3/4 ODT x 1/2" MPT
111Q0351043	Connection, 1-1/4 ODF x 1-1/4" MPT
111Q0351070	Elbow, 3/8 x 1/2" MPT
111Q0351098	Connection, Steel, 1 ODT x 1" FPT
111Q0450048	Elbow, 1-1/4 ODT x 1" MPT
111Q0450779	Tubing, Vinyl, 1/2 OD x 3/8" ID
111Q0880337	Tubing, Stainless Steel, 3/8 x .035" wall
111Q0880339	Tubing, Steel, 1 x .049" wall
111Q0880419	Tubing, Steel, 1-1/4 x .065" wall
111Q0880452	Tubing, Stainless Steel, 1/4 x .035" wall
333Q0000012	Connection, Steel, 3/4 ODT x 3/4" FPT
941A0035H08	Tubing, Steel, 1/2 x .035" wall
941A0035H09	Tubing, Steel, 3/4 x .049" wall
941A0035H10	Tubing, Steel, 1 x .049" wall
941A0035H11	Tubing, Steel, 1-1/4 x .065" wall
944A0113H02	Elbow, Stainless Steel, 1/4 ODT x 1/4" MPT
944A0113H03	Elbow, Stainless Steel, 3/8 ODT x 1/4" MPT
944A0113H05	Elbow, Stainless Steel, 3/8 ODT x 3/8" MPT
944A0116H02	Connection, Stainless Steel, 1/4 ODT x 1/4" MPT
944A0116H05	Connection, Stainless Steel, 3/8 ODT x 1/4" MPT
944A0116H07	Connection, Stainless Steel, 3/8 ODT x 3/8" MPT
944A0117H01	Connection, Stainless Steel, 1/4 ODT x 1/8" FPT
944A0117H05	Connection, Stainless Steel, 3/8 ODT x 1/2" FPT
944A0118H01	Union, Stainless Steel, 1/4 ODT x 1/4" ODT
944A0118H02	Union, Stainless Steel, 3/8 ODT x 3/8" ODT
944A0119H02	Tee Union, Stainless Steel, 3/8" Tube

ITEM NUMBER	FIG. & INDEX NO.	ITEM NUMBER	FIG. & INDEX NO.	ITEM NUMBER	FIG. & INDEX NO.
82407549909	14—1	111Q0451159	31—11	111Q0940163	16—32
82408536209	14—1	111Q0451159	33—3	111Q0940163	18—8
960A0078H41	12—5	111Q0451160	31—12	111Q0940164	17—32
111Q0019539	20—24	111Q0451160	33—4	111Q0940164	17—32
111Q0041148	2—3	111Q0451178	31—10	111Q0940169	15—27
111Q0068849	31—29	111Q0451178	33—2	111Q0940169	16—31
111Q0068849	31—31	111Q0451313	2—5	111Q0940170	17—31
111Q0068849	31—33	111Q0451635	31—36	333Q0000068	31—4
111Q0068849	33—8	111Q0451637	31—35	333Q0000068	32—6
111Q0068849	33—10	111Q0452442	31—17	333Q0000116	31—39
111Q0110110	15—4	111Q0452442	33—6	333Q0000116	32—8
111Q0110535	17—20	111Q0452524	15—26	333Q0000116	34—29
111Q0110535	17—20	111Q0452524	16—30	333Q0000117	31—22
111Q0110603	16—10	111Q0452525	17—30	333Q0000117	32—13
111Q0110603	16—10	111Q0452526	15—23	333Q0000118	33—11
111Q0110603	16—10	111Q0452527	16—27	333Q0000194	31—18
111Q0280687	31—30	111Q0452528	16—27	333Q0000195	31—19
111Q0280687	33—9	111Q0452530	17—27	333Q0000196	34—34
111Q0280818	8—7	111Q0740052	16—43	333Q0000206	31—16
111Q0280832	31—7	111Q0740052	18—9	333Q0000206	34—34
111Q0280832	32—11	111Q0740666	15—39	333Q0000207	31—17
111Q0280833	31—8	111Q0740666	16—43	333Q0000207	34—34
111Q0280833	32—12	111Q0740666	18—9	333Q0000211	31—14
111Q0280853	8—9	111Q0740746	2—9	333Q0000212	31—15
111Q0280854	8—8	111Q0740748	2—9	333Q0000261	31—9
111Q0280854	8—9	111Q0740748	2—11	333Q0000261	33—1
111Q0280887	8—8	111Q0740771	2—9	333Q0000517	8—16
111Q0280916	31—37	111Q0740772	2—9	333Q0000547	31—13
111Q0280930	31—25	111Q0740782	2—9	333Q0000547	32—7
111Q0280930	32—9	111Q0740782	2—11	333Q0000566	31—27
111Q0280933	32—10	111Q0740792	2—11	333Q0000573	31—21
111Q0280934	32—13	111Q0740797	2—9	333Q0000573	32—14
111Q0280938	32—8	111Q0740808	2—9	333Q0000681	31—42
111Q0280958	31—23	111Q0740808	2—11	333Q0000789	31—39
111Q0280958	33—13	111Q0740809	2—9	333Q0000789	34—30
111Q0280958	34—34	111Q0740822	17—44	333Q0000897	31—16
111Q0280973	31—37	111Q0740877	2—9	333Q0000897	34—34
111Q0280981	31—21	111Q0740878	8—16	333Q0000898	31—18
111Q0280981	32—13	111Q0940012	16—20	333Q0000899	31—9
111Q0281039	31—21	111Q0940012	17—21	333Q0000934	31—36
111Q0281039	32—14	111Q0940012	20—28	333Q0001099	8—13
111Q0281053	31—28	111Q0940019	15—40	333Q0001116	31—37
111Q0281053	31—32	111Q0940019	16—44	333Q0001117	31—37
111Q0281053	33—7	111Q0940019	16—44	333Q0001118	31—37
111Q0281059	31—20	111Q0940019	18—9	333Q0001183	31—34
111Q0281061	31—40	111Q0940022	15—38	333Q0001183	34—5
111Q0281061	32—8	111Q0940022	16—44	333Q0001185	34—6
111Q0281061	34—28	111Q0940022	18—9	333Q0001191	34—7
111Q0450361	31—24	111Q0940026	16—42	333Q0001192	34—8
111Q0450790	31—26	111Q0940028	17—43	333Q0001194	34—10
111Q0450790	33—12	111Q0940028	17—45	333Q0001195	34—11
111Q0451137	3—5	111Q0940048	16—5	333Q0001196	34—12
111Q0451152	31—16	111Q0940051	3—15	333Q0001199	34—4
111Q0451152	33—5	111Q0940136	31—6	333Q0001236	4—9
111Q0451153	33—6	111Q0940163	15—28	333Q0001236	6—13

RWB II ROTARY SCREW COMPRESSOR UNIT  
NUMERICAL PARTS LIST



ITEM NUMBER	FIG. & INDEX NO.	ITEM NUMBER	FIG. & INDEX NO.	ITEM NUMBER	FIG. & INDEX NO.
333Q0001237	6—15	535A0144H01	6—6	540D0217G03	3—13
333Q0001258	34—16	535A0154G01	10—3	540D0217H06	3—11
333Q0001268	6—9	535A0181H01	3—7	547C0008G01	10—6
333Q0001326	34—31	535A0181H02	3—7	547C0010G01	10—6
333Q0001345	8—9	535A0181H03	3—7	547C0011G01	10—6
333Q0001404	34—37	535A0181H04	3—7	547C0012G01	10—6
333Q0001418	34—35	535A0181H05	3—7	547C0013G01	10—6
333Q0001425	34—36	535A0181H08	3—7	547C0071G01	10—6
333Q0001489	34—15	535A0292H05	8—16	547C0178G01	10—6
333Q0001495	34—1A	535A0351H01	4—5	547C0188G01	10—6
333Q0001582	34—1A	535A0367H01	9—2	547D0079G01	10—6
420048382GR	21—15	535A0367H02	9—2	547D0079G02	10—6
420092125GR	21—17	535A0368H01	9—2	547D0079G03	10—6
420092202GR	21—17	535A0369H01	9—2	547D0079G04	10—6
420092241GR	21—17	535A0391G01	10—3	547D0079G05	10—6
420092241GR	22—15	535C0133H01	2—7	547D0079G09	10—6
420095244GR	21—15	535C0232G01	15—2	547D0079G10	10—6
420098167GR	21—15	535C0232G02	16—2	547D0172G01	10—6
420098283GR	22—10	535C0232G03	16—2	547D0211G01	10—6
420801048GR	22—13	535C0232G04	16—2	547D0212G01	10—6
421611056GR	21—18	535C0232G09	15—1	547D0213G01	10—6
421642107GR	21—18	535C0232G10	16—1	547D0214G01	10—6
421642109GR	21—18	535C0232G11	16—1	547D0215G01	10—6
421642109GR	22—16	535C0232G12	16—1	547D0216G01	10—6
480012225GR	21—16	535C0232G13	17—1	547D0217G01	10—6
480012300GR	21—16	535C0232G14	17—1	547D0218G01	10—6
480012400GR	21—16	535C0232G15	17—2	547D0219G01	10—6
480012400GR	22—14	535C0232G16	17—2	547D0220G01	10—6
480012500GR	22—14	535C0239H01	2—7	547D0221G01	10—6
531A0028H01	4—1	535C0348H01	26—1	547D0222G01	10—6
531A0048G35	3—16	535D0190C02	18—10	547D0268G01	10—6
531A0048G36	3—16	535D0191C02	18—10	547D0269G01	10—6
531A0048G37	3—16	535D0195C02	18—10	547D0485G01	10—6
531A0048G38	3—16	535D0196C02	18—10	547D0486G01	10—6
531A0048G39	3—16	535D0335G01	5—1	547D0487G01	10—6
531A0048G40	3—16	535D0345G01	5—1	547D0488G01	10—6
531A0048G41	3—16	535D0346G01	5—1	547D0490G01	10—6
531A0105H03	3—1	535D0347G01	5—1	547D0491G01	10—6
531A0105H04	3—1	535D0518G01	5—1	547D0492G01	10—6
531A0139H01	13—8	535D0524G01	5—1	547D0493G01	10—6
531A0205H01	4—6	535M0049G01	4—9	547D0494G01	10—6
531A0218H01	4—1	535M0049G02	4—9	547D0495G01	10—6
531A0218H01	6—10	535M0049G03	4—9	547D0496G01	10—6
531B0019H01	3—10	535M0197G01	9—7	547D0497G01	10—6
531B0099H01	3—10	535M0197G02	9—7	547D0498G01	10—6
534B0325H01	8—21	536A1419H01	3—9	547D0499G01	10—6
534B0501H01	2—4	540C0608H01	10—6	547D0500G01	10—6
534D0523G02	2—4	540C0608H02	10—6	547D0501G01	10—6
534M0163G01	2—6	540C0608H03	10—6	547D0502G01	10—6
534M0163G02	2—6	540C0608H04	10—6	547D0503G01	10—6
534M0163G03	2—6	540C0608H05	10—6	547D0504G01	10—6
534M0163G04	2—6	540C0608H06	10—6	547D0620G08	10—6
534M0163G05	2—6	540C0608H11	10—6	547D0620G09	10—6
535A0015H01	3—6	540C0608H12	10—6	547D0620G10	10—6
535A0144H01	4—2	540D0217G02	3—12	547D0620G11	10—6

ITEM NUMBER	FIG. & INDEX NO.	ITEM NUMBER	FIG. & INDEX NO.	ITEM NUMBER	FIG. & INDEX NO.
550657045GR	21—14	580A0230H01	17—39	580C0254C02	15—22
550657046GR	21—14	580A0231H01	15—33	580C0255H02	15—36
550657051GR	21—14	580A0231H02	16—37	580C0255H02	18—6
550657051GR	21—14	580A0231H03	16—37	580C0262C01	17—26
550840109GR	22—6	580A0232H01	17—37	580C0264C01	17—26
550840113GR	22—6	580A0234H01	17—40	580C0268H01	17—41
550840194GR	21—11	580A0234H02	17—40	580C0269H01	17—41
550840252GR	21—11	580A0235H01	15—25	580C0300H01	16—35
550845210GR	21—13	580A0235H01	16—29	580C0301H01	17—36
550845213GR	21—13	580A0235H01	19—14	580C0302H01	17—36
550845217GR	21—13	580A0235H03	17—29	580C0357G09	3—3
550845217GR	21—13	580A0275H02	15—7	580C0358G09	3—3
550845339GR	21—11	580A0275H02	19—21	580C0361G09	3—3
550845354GR	21—11	580A0275H03	16—7	580C0362G09	3—3
550940233GR	21—12	580A0275H03	20—21	580D0019G02	12—1
550940238GR	21—12	580A0275H04	16—7	580D0047G02	17—46
550940245GR	21—12	580A0275H04	20—21	580D0165G11	10—5
550940245GR	21—12	580A0275H05	17—7	581A0001H04	17—22
550940247GR	22—5	580A0275H06	17—7	581A0007H01	17—16
550940253GR	22—5	580B0240G02	15—21	581A0010H03	16—4
553A0001H01	6—3	580B0240G02	18—3	581A0010H03	19—19
580A0090H02	15—18	580B0240G04	16—25	581A0010H03	20—19
580A0090H02	16—22	580B0240G04	18—3	581A0010H04	16—4
580A0090H02	16—22	580B0240G06	16—25	581A0010H04	20—19
580A0090H02	19—8	580B0240G06	18—3	581A0011H02	16—5
580A0090H02	20—8	580B0240G07	17—25	581A0011H03	16—5
580A0090H02	20—8	580B0240G08	17—25	581A0011H03	17—5
580A0095H01	16—23	580B0241H01	15—29	581A0011H03	20—18
580A0095H01	20—7	580B0241H03	16—33	581A0011H04	17—5
580A0096H01	15—17	580B0242G01	15—24	581A0011H07	15—5
580A0096H01	16—18	580B0242G01	16—28	581A0011H07	19—18
580A0096H01	19—9	580B0243G01	17—28	581A0011H07	20—18
580A0096H01	20—9	580B0246G02	15—30	581A0012H01	16—14
580A0108H01	16—18	580B0246G02	18—4	581A0012H01	20—11
580A0108H01	20—9	580B0246G04	16—34	581A0013H03	16—17
580A0109H01	16—23	580B0246G04	18—4	581A0014H01	16—21
580A0109H01	20—7	580B0246G06	16—34	581A0014H01	20—26
580A0183H06	20—29	580B0246G06	18—4	581A0015H01	16—21
580A0183H07	20—29	580B0246G07	17—34	581A0015H01	20—26
580A0192H01	16—22	580B0246G08	17—34	581A0016H01	16—21
580A0192H01	20—8	580B0271H01	15—31	581A0016H01	20—26
580A0218H01	19—24	580B0272H01	16—35	581A0017H01	17—19
580A0218H01	20—24	580B0272H01	16—35	581A0019H01	17—19
580A0219H01	19—23	580B0273H02	15—32	581A0020H01	17—14
580A0219H01	20—23	580B0273H04	16—36	581A0022H02	15—19
580A0219H03	19—23	580B0273H06	16—36	581A0022H02	19—7
580A0219H04	20—23	580B0273H07	17—35	581A0023H01	16—14
580A0223H01	19—24	580B0273H08	17—35	581A0023H01	20—11
580A0226H01	15—35	580C0044C01	16—16	581A0024H01	16—11
580A0226H01	18—7	580C0250H02	16—40	581A0024H01	20—13
580A0227H01	16—39	580C0250H02	18—6	581A0027H01	19—14
580A0227H01	18—7	580C0251C02	16—26	581A0027H01	20—14
580A0228H01	16—39	580C0252C02	16—26	581A0027H02	20—14
580A0228H01	18—7	580C0253H02	16—40	581A0030H01	17—14
580A0229H01	17—39	580C0253H02	18—6	581A0040H01	16—17

RWB II ROTARY SCREW COMPRESSOR UNIT  
NUMERICAL PARTS LIST



ITEM NUMBER	FIG. & INDEX NO.	ITEM NUMBER	FIG. & INDEX NO.	ITEM NUMBER	FIG. & INDEX NO.
581A0040H01	20—25	581C0042H01	16—8	640C0026G02	34—33
581A0040H02	16—17	581C0042H01	20—4	640C0052G01	34—1
581A0040H02	20—25	581C0043C01	16—16	640D0011H01	31—2
581A0040H03	20—25	581C0045H01	16—8	640D0021H01	31—1
581A0040H04	17—18	581C0045H01	20—4	640D0060H01	34—23
581A0040H05	17—18	581C0046G05	19—6	640M0008G01	32—2
581A0042H01	17—11A	581C0046G06	15—16	649A0260H01	31—41
581A0043H01	17—11A	581C0046G06	19—6	649A0264H01	31—5
581A0044H01	17—15	581C0048C01	16—9	649A0883H10	34—13
581A0044H02	17—15	581C0048C01	20—3	649A0883H16	34—14
581A0046H01	17—12	581C0049C01	16—16	649B0862H01	34—9
581A0047H01	17—12	581C0050H01	17—6	649C1091G01	34—24
581B0001H03	15—3	581C0051H01	17—6	649D0979H01	31—3
581B0001H03	19—17	581C0063C01	20—2	649D0979H01	32—3
581B0001H04	16—3	581C0071G01	17—17	649D4824H01	34—20
581B0001H04	20—17	581C0072G01	17—17	649M0031G11	34—38
581B0001H05	16—3	581C0074G01	17—9	724000374GR	22—3
581B0001H05	20—17	581C0078H01	17—9	724000375GR	22—8
581B0001H06	17—3	581C0086C02	19—3	724000494GR	22—3
581B0001H07	17—3	581C0087C03	15—9	724000495GR	22—8
581B0003H06	17—23	581C0087C03	19—3	724000550GR	22—9
581B0003H07	17—23	581C0104C01	19—2	724000551GR	22—9
581B0009H01	17—8	581C0105C01	19—2	724000552GR	22—7
581B0010H01	17—8	581C0110G01	19—1	724000553GR	22—7
581B0030H02	19—4	581C0110G02	19—1	724000599GR	22—4
581B0030H03	15—8	581C0110G03	20—1	724000600GR	22—4
581B0030H03	19—4	581C0110G04	20—1	724000620GR	22—11
581B0032H01	15—11	581C0110G05	20—1	724000621GR	22—11
581B0032H01	19—13	581C0139C01	20—6	724000641GR	22—2
581B0033H02	15—14	581C0142C01	20—6	724000642GR	22—12
581B0033H02	19—11	581C0144C01	20—6	724000643GR	22—2
581B0045H01	16—11	581D0032C01	16—9	724000644GR	22—12
581B0045H01	20—13	581D0032C01	20—3	724001061GR	21—5
581B0052H04	19—15	581D0033C01	16—9	724001062GR	21—5
581B0052H05	19—15	581D0033C01	20—3	724001063GR	21—5
581B0066H01	17—11	581D0045C01	20—2	724001064GR	21—5
581B0067H01	17—11	581D0047C01	20—2	724003174GR	21—1
581B0080H01	20—15	619A0264H01	32—4	724003177GR	21—1
581B0081H01	20—15	640A0020G01	31—41	724003183GR	21—1
581B0082H01	20—15	640A0032H01	34—3	724003210GR	21—7
581B0086H01	20—31	640A0033H01	8—7	724003212GR	21—7
581B0086H02	20—31	640A0035H01	8—7	724003216GR	21—7
581B0100H01	20—5	640A0038H10	8—7	724003235GR	21—3
581B0100H02	20—5	640A0051H01	8—7	724003237GR	21—3
581B0100H03	20—5	640B0019H01	31—38	724003239GR	21—3
581B0100H04	19—5	640B0019H01	32—5	724003241GR	21—3
581B0100H05	19—5	640B0031H01	34—18	724003260GR	21—4
581C0001H04	16—6	640B0038H01	34—21	724003262GR	21—4
581C0001H04	20—20	640B0048H01	34—2	724003266GR	21—4
581C0001H05	16—6	640B0049H01	34—25	724003266GR	21—4
581C0001H05	20—20	640C0010G01	32—2	724003285GR	21—2
581C0001H09	15—6	640C0022G01	34—2	724003287GR	21—2
581C0001H09	19—20	640C0024G01	34—26	724003289GR	21—2
581C0037H01	16—8	640C0024G02	34—27	724003291GR	21—2
581C0037H01	20—4	640C0026G01	34—32	724003310GR	21—9

ITEM NUMBER	FIG. & INDEX NO.	ITEM NUMBER	FIG. & INDEX NO.	ITEM NUMBER	FIG. & INDEX NO.
724003312GR	21—9	901A0098H14	10—6	914A0016H02	12—5
724003314GR	21—9	901A0098H14	10—6	914A0016H02	14—8
724003316GR	21—9	901A0098H16	10—6	914A0016H03	12—5
724003335GR	21—10	901A0098H19	10—6	914A0016H04	12—5
724003337GR	21—10	901A0098H21	10—6	914A0016H05	12—5
724003341GR	21—10	901A0098H21	10—6	914A0016H06	12—5
724003341GR	21—10	901A0098H22	10—6	914A0016H07	12—5
724003460GR	21—6	901A0098H24	10—6	914A0016H10	12—5
724003462GR	21—6	901A0098H31	10—6	914A0016H11	12—5
724003466GR	21—6	901A0172H03	11—7	914A0016H11	12—5
724003485GR	21—8	901A0172H03	14—7	914A0016H20	14—8
724003487GR	21—8	901A0172H05	11—7	914A0016H23	14—8
724003491GR	21—8	901A0172H05	14—7	914A0057H01	9—7
724003612GR	21—19	902A0021H01	3—14	914A0057H02	9—7
724003614GR	21—19	902A0021H01	6—16	914A0057H03	9—7
724003616GR	21—19	902A0021H01	10—6	914A0057H04	9—7
724003618GR	22—17	902A0021H03	4—8	944A0008H02	15—34
724003662GR	21—20	902A0021H03	6—5	944A0008H02	16—38
724003664GR	21—20	902A0021H03	10—6	944A0008H02	17—38
724003666GR	21—20	905A0007H05	6—14	944A0010H01	3—8
724003668GR	22—18	913A0047H01	3—5	944A0108H05	11—5
900A0007H01	4—9	913A0047H02	3—5	944A0108H05	14—5
900A0007H01	6—11	913A0047H03	3—5	944A0108H07	11—5
900A0008H01	4—9	913A0047H04	3—5	944A0108H07	14—5
900A0008H01	6—12	913A0102H02	6—17	944A0117H01	13—10
901A0043B03	16—19	913A0110H01	8—9	944A0126H10	10—9
901A0043D05	4—4	913A0110H01	26—3	944A0358H01	25—3
901A0043D05	6—8	913A0110H02	8—8	944A0358H02	25—3
901A0043E03	20—27	913A0110H02	26—3	944A0358H03	25—3
901A0045A03	17—4	913A0110H04	8—9	944A0358H05	25—3
901A0046A03	20—16	913A0110H04	26—3	944A0360G09	10—7
901A0046A03	20—16	913A0110H05	8—8	944A0360G11	9—8
901A0046A04	15—37	913A0110H05	8—9	944A0360G11	10—7
901A0046A04	19—16	913A0110H05	26—3	944A0360G12	10—7
901A0046A05	17—10	914A0015H02	9—7	945A0031H01	8—17
901A0046D03	20—16	914A0015H02	12—5	947A0003H05	3—2
901A0046D04	15—37	914A0015H02	14—8	950A0001H02	8—13
901A0046H01	17—4	914A0015H03	9—7	950A0001H05	25—2
901A0047A05	15—10	914A0015H03	12—5	950A0001H06	25—2
901A0047A05	16—41	914A0015H03	14—8	950A0001H07	11—2
901A0047A05	19—16	914A0015H04	9—7	950A0001H07	12—4
901A0047A06	16—41	914A0015H07	9—7	950A0001H07	14—3
901A0047D05	16—41	914A0015H08	9—7	950A0001H08	9—6
901A0047D06	16—41	914A0015H09	9—7	950A0001H09	12—4
901A0048A06	17—42	914A0015H10	9—7	950A0001H09	25—2
901A0048A07	17—42	914A0015H11	9—7	950A0001H11	25—2
901A0048A07	17—44	914A0015H12	9—7	950A0001H21	8—13
901A0048D06	17—42	914A0015H13	9—7	950A0001H24	25—2
901A0097H11	10—6	914A0015H13	12—5	950A0001H25	25—2
901A0098H09	10—6	914A0015H13	14—8	950A0001H26	11—2
901A0098H10	10—6	914A0015H14	14—8	950A0001H26	12—4
901A0098H11	4—7	914A0015H15	12—5	950A0001H26	14—3
901A0098H11	6—4	914A0015H15	14—8	950A0001H27	9—6
901A0098H11	10—6	914A0015H16	14—8	950A0001H28	12—4
901A0098H12	10—6	914A0016H01	12—5	950A0001H28	25—2

RWB II ROTARY SCREW COMPRESSOR UNIT  
NUMERICAL PARTS LIST



ITEM NUMBER	FIG. & INDEX NO.	ITEM NUMBER	FIG. & INDEX NO.	ITEM NUMBER	FIG. & INDEX NO.
950A0001H29	25—2	950A0067G01	10—8	950A0222H11	11—8
950A0001H31	8—13	950A0068G01	10—8	950A0233H01	8—11
950A0001H33	25—2	950A0069H03	13—3	950A0233H01	13—2
950A0001H34	9—6	950A0069H04	13—3	950A0233H02	13—2
950A0001H34	25—2	950A0069H05	13—3	950A0233H03	13—2
950A0001H35	11—2	950A0069H07	9—6	950A0233H04	13—2
950A0001H35	12—4	950A0069H07	11—2	950A0233H05	5—2
950A0001H35	14—3	950A0069H07	12—4	950A0233H05	6—18
950A0001H36	12—4	950A0069H07	13—3	950A0233H05	7—2
950A0001H36	25—2	950A0069H07	14—3	950A0233H05	8—10
950A0001H37	25—2	950A0069H08	11—2	950A0233H05	9—3
950A0001H40	9—6	950A0069H08	14—3	950A0233H05	9—5
950A0001H41	11—2	950A0069H21	13—3	950A0233H05	10—4
950A0001H41	14—3	950A0069H22	13—3	950A0233H05	12—6
950A0012H01	13—3	950A0069H23	13—3	950A0233H06	5—2
950A0012H04	13—3	950A0069H23	13—3	950A0233H06	6—18
950A0018G01	13—3	950A0069H25	9—6	950A0233H06	7—2
950A0018G02	13—3	950A0069H25	11—2	950A0233H06	8—10
950A0019H01	8—2	950A0069H25	12—4	950A0233H06	9—5
950A0019H01	9—6	950A0069H25	13—3	950A0233H06	10—4
950A0019H01	13—3	950A0069H25	14—3	950A0233H06	11—1
950A0019H02	8—2	950A0069H33	13—3	950A0233H06	12—6
950A0019H02	9—6	950A0069H34	13—3	950A0233H06	14—1
950A0019H03	8—2	950A0069H35	13—3	950A0236H02	9—3
950A0019H03	9—6	950A0069H37	9—6	950A0237H01	9—4
950A0019H04	8—2	950A0069H37	11—2	950A0237H01	13—2
950A0019H04	9—6	950A0069H37	12—4	950A0237H02	13—2
950A0019H04	13—3	950A0069H37	14—3	950A0237H03	13—2
950A0020H01	9—2	950A0069H38	11—2	950A0237H04	9—3
950A0020H02	9—2	950A0069H38	14—3	950A0240H09	18—1
950A0021G03	13—3	950A0075H08	10—9	950A0240H10	18—1
950A0021G04	13—3	950A0075H09	10—9	950A0240H11	18—1
950A0021G05	13—3	950A0075H26	10—9	950A0240H12	18—1
950A0023H01	9—2	950A0075H28	10—9	950A0240H26	18—1
950A0023H02	9—2	950A0075H29	10—9	950A0240H27	18—1
950A0027H01	10—2	950A0075H46	10—9	950A0240H28	18—1
950A0027H02	10—2	950A0075H48	10—9	950A0240H29	18—1
950A0027H03	10—2	950A0075H49	10—9	950A0240H34	18—1
950A0027H04	10—2	950A0085G02	12—1	950A0240H35	18—1
950A0027H05	10—2	950A0089H02	12—1	950A0240H36	18—1
950A0027H06	10—2	950A0117H02	10—5	950A0240H46	18—1
950A0028G31	10—8	950A0137G02	12—1	950A0240H47	18—1
950A0028H01	10—8	950A0186G01	13—3	950A0240H48	18—1
950A0028H21	10—8	950A0186G02	13—3	950A0240H49	18—1
950A0029G31	10—8	950A0186G03	13—3	950A0240H55	18—1
950A0029H01	10—8	950A0187G01	13—3	950A0240H56	18—1
950A0029H21	10—8	950A0187G02	13—3	950A0240H57	18—1
950A0030G31	10—8	950A0187G03	13—3	950A0241H05	9—5
950A0030H01	10—8	950A0188G01	13—3	950A0241H05	12—6
950A0030H21	10—8	950A0190H01	13—3	950A0241H06	9—5
950A0042G01	13—3	950A0190H03	13—3	950A0241H07	5—2
950A0046H01	10—8	950A0195H01	11—8	950A0241H07	6—18
950A0054H01	13—3	950A0195H02	11—8	950A0241H07	7—2
950A0054H04	13—3	950A0195H11	11—8	950A0241H07	8—10
950A0066G01	10—8	950A0222H01	11—8	950A0241H07	9—5

ITEM NUMBER	FIG. & INDEX NO.	ITEM NUMBER	FIG. & INDEX NO.	ITEM NUMBER	FIG. & INDEX NO.
950A0241H07	10—4	951A0057H01	13—10	955A0008H01	8—3
950A0241H07	11—1	951A0060H04	8—13	955A0012H01	3—3
950A0241H07	12—6	951A0060H05	8—13	955A0012H02	3—3
950A0241H07	14—1	951A0060H06	8—13	955A0023H01	3—3
950A0241H08	5—2	951A0065H01	13—3	955A0024H01	3—3
950A0241H08	6—18	951A0066H01	13—3	956A0012G01	8—18
950A0245H01	13—1	952A0019H10	3—3	956A0012G03	8—18
950A0245H02	13—1	952A0019H10	10—1	956A0012G03	11—4
950A0245H03	13—1	952A0020H10	3—3	956A0012G03	12—7
950A0245H04	13—1	952A0021H09	3—3	956A0012G03	14—4
950A0245H05	7—3	952A0022H09	3—3	956A0012G04	9—1
950A0245H05	13—1	952A0025H01	10—1	956A0012G05	8—18
950A0245H06	7—3	954A0007H01	12—2	956A0012G05	11—4
950A0249H01	13—1	954A0007H03	12—2	956A0012G05	12—7
950A0249H02	13—1	954A0007H06	12—2	956A0012G05	14—4
950A0249H03	13—1	954A0007H07	12—2	956A0012G06	8—18
950A0249H04	13—1	954A0008H01	13—4	956A0012G06	12—3
950A0253H07	7—3	954A0008H02	13—4	956A0012G06	12—7
951A0006H07	8—13	954A0008H03	13—4	956A0012G10	11—4
951A0006H14	8—13	954A0010H20	13—9	956A0012G10	12—7
951A0007H07	8—19	954A0010H30	13—9	956A0014H01	12—3
951A0009H01	8—13	954A0012H20	13—9	956A0014H01	14—9
951A0009H01	8—19	954A0012H30	13—9	956A0014H02	12—3
951A0009H03	8—13	954A0012H30	13—9	956A0014H02	14—9
951A0009H05	8—13	954A0014H01	8—20	956A0014H03	9—1
951A0009H07	8—13	954A0032H01	8—5	956A0018H01	8—4
951A0020H01	13—11	954A0032H02	8—5	956A0025H22	25—1
951A0020H11	13—11	954A0033H01	6—19	956A0025H23	25—1
951A0037H14	12—4	954A0033H01	7—5	956A0025H24	25—1
951A0037H15	12—4	954A0033H01	8—5	956A0025H25	25—1
951A0037H16	9—6	954A0033H02	6—19	956A0025H26	25—1
951A0037H16	12—4	954A0033H02	7—5	956A0031H02	8—17
951A0037H16	13—3	954A0033H02	8—5	956A0031H03	8—17
951A0037H24	12—4	954A0047H01	6—19	956A0031H04	8—17
951A0037H25	12—4	954A0047H01	7—5	956A0031H07	8—17
951A0037H26	9—6	954A0047H01	8—5	956A0031H08	8—17
951A0037H26	12—4	954A0047H02	6—19	956A0031H11	8—17
951A0037H34	12—4	954A0050H01	13—9	956A0031H12	8—17
951A0037H35	12—4	954A0050H02	13—9	957A0003H01	5—3
951A0037H36	9—6	954A0050H03	13—9	957A0003H01	6—17
951A0037H36	12—4	954A0050H04	13—9	957A0003H01	7—4
951A0041H01	13—3	954A0050H05	13—9	957A0003H01	8—1
951A0053G01	13—10	954A0050H06	13—9	957A0003H01	8—14
951A0053G11	13—10	954A0050H07	13—9	957A0003H01	11—3
951A0053H01	13—10	954A0050H08	13—9	957A0003H01	13—5
951A0054H01	13—10	954A0050H09	13—9	957A0003H01	14—2
951A0054H01	13—10	954A0051H01	13—9	957A0003H01	19—25
951A0056H34	8—16	954A0051H02	13—9	957A0003H01	20—30
951A0056H39	8—16	954A0051H03	13—9	957A0003H01	26—2
951A0056H40	8—16	954A0051H04	13—9	957A0003H02	8—6
951A0056H41	8—16	954A0051H06	13—9	957A0003H02	13—6
951A0056H42	8—16	954A0051H07	13—9	957A0003H02	16—45
951A0056H43	8—16	954A0051H08	13—9	957A0003H02	17—46
951A0056H44	8—16	954A0051H09	13—9	959A0018H10	10—6
951A0057G01	13—10	954A0051H10	13—9	959A0018H12	10—6

RWB II ROTARY SCREW COMPRESSOR UNIT  
NUMERICAL PARTS LIST



ITEM NUMBER	FIG. & INDEX NO.	ITEM NUMBER	FIG. & INDEX NO.	ITEM NUMBER	FIG. & INDEX NO.
959A0022H06	15—15	959A0057H05	25—1	959A0089H04	13—12
959A0022H07	16—15	959A0057H05	25—3	960A0043H03	9—7
959A0022H08	16—15	959A0057H07	10—7	960A0043H04	9—7
959A0022H09	16—15	959A0057H07	25—1	960A0043H06	9—7
959A0038H06	17—24	959A0057H07	25—3	960A0043H07	9—7
959A0040H15	10—6	959A0057H09	25—1	960A0043H11	9—7
959A0040H16	10—6	959A0057H18	25—1	960A0043H11	9—7
959A0040H17	10—6	959A0057H18	25—3	960A0043H20	9—7
959A0040H18	10—6	959A0061H01	18—5	960A0043H51	9—7
959A0040H19	10—6	959A0061H02	16—33	960A0043H51	9—7
959A0040H50	10—6	959A0061H02	18—5	960A0043H51	9—7
959A0043H01	10—6	959A0061H03	18—5	960A0043H51	9—7
959A0043H02	10—6	959A0061H04	17—33	960A0060H01	12—5
959A0043H03	10—6	959A0061H05	17—33	960A0060H02	12—5
959A0043H04	10—6	959A0062H01	2—2	960A0060H11	12—5
959A0053H01	4—3	959A0062H01	15—20	960A0060H11	12—5
959A0053H01	6—7	959A0062H01	18—2	960A0060H20	12—5
959A0054H06	10—9	959A0062H02	2—2	960A0060H21	12—5
959A0054H08	10—9	959A0062H02	16—24	960A0060H30	12—5
959A0054H25	11—6	959A0062H02	18—2	960A0060H31	12—5
959A0054H25	14—6	959A0062H03	2—2	960A0060H41	12—5
959A0054H27	11—6	959A0062H03	2—8	960A0066G01	12—5
959A0054H27	14—6	959A0062H03	16—24	960A0066G02	9—7
959A0054H28	2—10	959A0062H03	18—2	960A0066G03	12—5
959A0054H28	3—4	959A0062H04	2—2	960A0066G04	9—7
959A0054H30	2—10	959A0062H04	2—8	960A0066G05	12—5
959A0054H30	3—4	959A0062H04	16—24	960A0066G06	9—7
959A0054H32	2—10	959A0062H04	18—2	960A0066G09	9—7
959A0054H32	3—4	959A0062H05	2—2	960A0066G10	9—7
959A0054H33	2—10	959A0062H05	17—24	960A0066G13	9—7
959A0054H33	3—4	959A0062H21	2—2	960A0066G14	9—7
959A0054H34	2—10	959A0062H21	18—2	960A0066G16	9—7
959A0054H34	3—4	959A0062H22	2—2	960A0066G18	9—7
959A0054H36	2—2	959A0062H22	18—2	960A0066G19	12—5
959A0055H01	16—12	959A0062H23	2—2	960A0066G20	9—7
959A0055H06	16—12	959A0062H23	2—8	960A0066G21	12—5
959A0055H06	20—12	959A0062H23	18—2	960A0066H01	9—7
959A0055H07	16—12	959A0062H24	2—2	960A0066H01	12—5
959A0055H07	20—12	959A0062H24	2—8	960A0066H01	12—5
959A0055H12	15—12	959A0062H24	18—2	960A0066H01	12—5
959A0055H12	19—12	959A0062H25	2—2	960A0066H01	12—5
959A0056H01	16—13	959A0063H01	4—6	960A0066H02	9—7
959A0056H06	16—13	959A0068H05	10—6	960A0066H02	12—5
959A0056H06	20—22	959A0075H06	10—9	960A0066H11	9—7
959A0056H07	16—13	959A0076H01	17—13	960A0066H11	9—7
959A0056H07	20—22	959A0076H02	17—13	960A0066H11	12—5
959A0056H12	15—13	959A0082H01	4—6	960A0066H11	12—5
959A0056H12	19—22	959A0082H01	6—2	960A0066H11	12—5
959A0057H03	10—7	959A0089H01	13—9	960A0066H11	12—5
959A0057H03	12—2	959A0089H01	13—12	960A0066H11	14—8
959A0057H04	12—2	959A0089H02	13—9	960A0066H12	9—7
959A0057H04	25—1	959A0089H02	13—12	960A0066H12	12—5
959A0057H04	25—3	959A0089H03	13—9	960A0066H12	14—8
959A0057H05	9—8	959A0089H03	13—12	960A0066H41	9—7
959A0057H05	10—7	959A0089H04	13—9	960A0066H41	12—5

ITEM NUMBER	FIG. & INDEX NO.	ITEM NUMBER	FIG. & INDEX NO.	ITEM NUMBER	FIG. & INDEX NO.
960A0066H51	12—5	980A0012B66	9—2		
960A0066H52	12—5	980A0012B76	9—2		
960A0067G01	12—5	980A0014H51	19—10		
960A0067G03	12—5	980A0014H59	15—14		
960A0067G05	12—5	980A0014H59	19—10		
960A0067G07	12—5	980A0014H67	16—14		
960A0067G09	12—5	980A0014H67	20—10		
960A0067H01	12—5	980A0014H71	16—14		
960A0067H02	12—5	980A0014H71	20—10		
960A0067H03	12—5	980A0014H80	16—14		
960A0067H11	12—5	980A0014H80	17—27		
960A0067H13	14—8	980A0014H80	20—10		
960A0067H41	12—5	980A0014K29	17—16		
960A0077H41	14—8	980A0014K33	17—16		
960A0078G03	12—5	980A0017H01	8—7		
960A0078G09	12—5	990A0003H02	8—15		
960A0078H01	12—5	990A0011H02	13—7		
960A0078H01	12—5	990A0014H01	8—7		
960A0078H21	12—5	990A0062H01	8—7		
960A0078H21	12—5				
960A0078H32	12—5				
960A0078H32	12—5				
960A0078H41	12—5				
960A0080G01	12—5				
960A0080G02	12—5				
960A0080G07	12—5				
960A0080G08	12—5				
960A0080H01	12—5				
960A0080H20	12—5				
960A0080H20	12—5				
960A0080H22	12—5				
960A0080H30	12—5				
960A0080H31	12—5				
960A0082G01	14—8				
960A0082G02	14—8				
960A0082G03	14—8				
960A0082G04	14—8				
960A0082G05	14—8				
960A0082G06	14—8				
960A0082G07	14—8				
960A0082G08	14—8				
960A0082G09	14—8				
960A0082G10	14—8				
960A0082G11	14—8				
960A0082G12	14—8				
960A0082G13	14—8				
960A0082G14	14—8				
960A0082H01	14—8				
960A0082H01	14—8				
960A0082H02	14—8				
960A0083G01	14—8				
960A0083G02	14—8				
960A0083G03	14—8				
960A0083G04	14—8				
960A0083H01	14—8				

**Form RWBII 070-200 SPL (0502)**  
Supersedes: RWBII S70-200 SPL (0501)  
Subject to change without notice  
Published in USA - PDF  
© 2009 Johnson Controls Inc. - ALL RIGHTS RESERVED



JOHNSON CONTROLS  
100 CV Avenue • P.O. Box 997  
Waynesboro, PA USA 17268-0997  
Phone: 717-762-2121 • FAX: 717-762-8624  
[www.johnsoncontrols.com](http://www.johnsoncontrols.com)