

4150K and 4160K Series Pressure Controllers and Transmitters

Wizard® II controllers and transmitters are used wherever durable, dependable, and simply constructed pressure-sensing instrumentation is required. The use of this line in all kinds of demanding applications, including those in the chemical process, gas, and oil production industries, demonstrates its versatility.

The 4150K and 4160K Series controllers, shown in figure 1, compare a sensed process pressure (or differential pressure) with an operator-adjusted set point, and send a pneumatic signal to an adjacent control element that maintains the process pressure at or near the set point value. The 4150K Series transmitters sense process pressure and send out a pneumatic signal, usually to an indicating or recording device that directly indicates the process pressure.

Unless otherwise noted, all NACE references are to NACE MR0175-2002.

Features

- **Wide Range of Sensing Elements**—A Bourdon tube is available for high pressures or bellows for vacuum and low pressures. Either kind of sensing element can be installed in the case with the controller or transmitter. Two interchangeable ranges of output bellows and gauges also are available.

- **Sour Service Capability**—Materials are available for applications handling sour process fluids. These constructions comply with the metallurgical requirements of NACE MR0175-2002. Environmental restrictions may apply.

- **Mounting Versatility**—Install the case on a panel, wall or pipestand, as well as directly on the control valve actuator.

- **Reduced Maintenance Costs**—A spring-out cleaning wire, shown in figure 5, provides for in-service cleaning of the relay orifice.



Figure 1. Wizard® II Controller Yoke-Mounted on Control Valve Actuator

- **Easy Conversion to Another Mode**—Add reset action to a proportional controller by adding only one valve and three pieces of tubing, as shown in figure 6. The original case may be used in either instance.

- **Easy Reversibility**—Switch action from direct to reverse or vice versa without additional parts. As illustrated in figure 7, simply transfer the reversing block to the opposite side of the flapper and change the feedback bellows frame tubing connections.

- **Easy, Accurate Adjustments**—Make pressure setting, proportional band, and reset changes with simple dial-knob controls that help to assure positive settings.

- **Sensitive Response**—Area ratio of large relay diaphragm to small relay diaphragm permits small nozzle pressure changes to induce much greater output pressure changes.



Specifications

Available Configurations

See table 1

Input Signal

Type: ■ Gauge pressure, ■ vacuum, ■ compound pressure, or ■ differential pressure of a liquid or gas

Limits: See table 2 or 3

Output Signal

Proportional or Proportional-Plus-Reset Controllers and Transmitters: ■ 0.2 to 1.0 bar (3 to 15 psig) or ■ 0.4 to 2.0 bar (6 to 30 psig) pneumatic pressure signal

Differential Gap Controllers: ■ 0 and 1.4 bar (0 and 20 psig) or ■ 0 and 2.4 bar (0 and 35 psig) pneumatic pressure signal

Action: Control action is field reversible between ■ direct (increasing sensed pressure produces increasing output signal) and ■ reverse (increasing sensed pressure produces decreasing output signal). The suffix R is added to the type number of a construction specified for reverse action.

Supply Pressure Requirements⁽¹⁾

See table 4

Supply Pressure Medium

Air or Natural Gas⁽²⁾

Steady-State Air Consumption

See figure 2

Supply and Output Connections

1/4 NPT internal

Supply and Output Pressure Gauge Ranges

See table 5

Proportional Band Adjustment

For Proportional and Proportional-Plus-Reset Controllers:

0.2 to 1.0 bar (3 to 15 psig) Output: Full output pressure change adjustable from 3 to 100% of the sensing element range.

0.4 to 2.0 bar (6 to 30 psig) Output: Full output pressure change adjustable from 6 to 100% of the sensing element range.

Differential Gap Adjustment

For Differential Gap Controllers: Full output pressure change adjustable from 15% to 100% of sensing element range

Reset Adjustment

For Proportional-Plus-Reset Controllers: Adjustable from 0.01 to 74 minutes per repeat (100 to 0.01 repeats per minute)

Zero Adjustment (Transmitters Only)

Continuously adjustable to position span of less than 100% anywhere within the sensing element range

Span Adjustment (Transmitters Only)

Full output pressure change adjustable from 6 to 100% of process sensing element range

Performance

Repeatability: 0.5% of sensing element range

Dead Band (Except Differential Gap Controllers⁽³⁾): 0.1% of output span

Typical Frequency Response at 100% Proportional Band:

Output to Actuator: 0.7 Hz and 110 degree phase shift with 1850 cm³ (113 inches³) volume actuator at mid-stroke

Output to Positioner Bellows: 9 Hz and 130 degree phase shift with 0.2 to 1.0 bar (3 to 15 psig) output to 33 cm³ (2 inches³) bellows

Ambient Operating Temperature Limits⁽¹⁾

■ **Standard Construction:** -40 to 93°C (-40 to 200°F)

■ **4160KF (w/Reset Relief):** -40 to 71°C (-40 to 160°F)

- Continued -

Specifications (continued)

Typical Ambient Temperature Operating Influence

Proportional Control only: Output pressure changes $\pm 3.0\%$ of sensing element rating for each 28°C (50°F) change in temperature between -40 and 71°C (-40 and 160°F) for a controller set at 100% proportional band

Reset Control only: Output pressure changes $\pm 2.0\%$ of sensing element rating for each 28°C (50°F) change in temperature between -40 and 71°C (-40 and 160°F) for a controller set at 100% proportional band

Transmitters only: Output pressure changes $\pm 3.0\%$ of sensing element rating for each 28°C

(50°F) change in temperature between -40 and 71°C (-40 and 160°F) for a transmitter set at 100% span

Hazardous Area Classification

Complies with the requirements of ATEX Group II Category 2 Gas and Dust

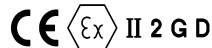

Construction Materials

See tables 2, 3, and 6

Approximate Weight

8.2 kg (18 pounds)

NOTE: Specialized instrument terms are defined in ANSI/ISA Standard 51.1 – Process Instrument Terminology.
1. The pressure and temperature limits in this document, and any applicable standard or code limitation should not be exceeded.
2. This product can be used with natural gas. Natural gas should contain no more than 20 ppm of hydrogen sulphide.
3. An adjustable differential gap (differential gap controllers) is equivalent to an adjustable deadband.

Table 1. Available Configurations

DESCRIPTION ⁽¹⁾		TYPE NUMBER ⁽²⁾		
		Bourdon Tube Sensing Element (Gauge Pressure Only)	Bellows Sensing Element	
			Gauge Pressure	Differential Pressure
Proportional controller		4150K	4152K	4154K
Proportional-plus-reset controller	Without anti-reset windup	4160K	4162K	4164K
	With anti-reset windup	4160KF	4162KF	---
Differential-gap controller		4150KS	4152KS	---
Transmitter		4157K	4158K	4155K

1. See figures 5 and 6 for construction details.
2. The suffix R is added to the type number of a construction specified for reverse action.

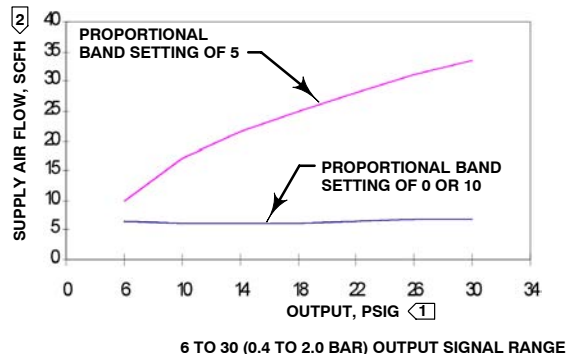
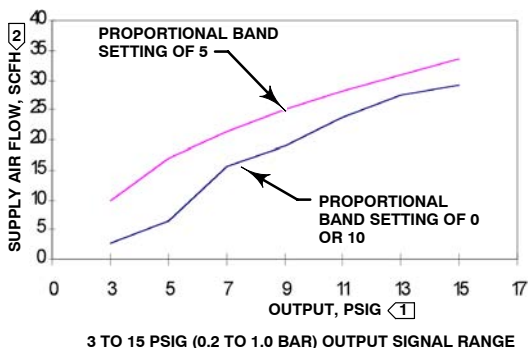

NOTES
 [1] TO CONVERT PSIG TO BAR, MULTIPLY BY 0.06895.
 [2] SCFH—STANDARD CUBIC FEET PER HOUR (60°F AND 14.7 PSIA).
 TO CONVERT TO NORMAL M³/HR—NORMAL CUBIC METERS PER HOUR (0°C AND 1.01325 BAR, ABSOLUTE), MULTIPLY BY 0.0268

A7242 / IL

Figure 2. Steady-State Air Consumption

4150K/4160K Controllers and Transmitters

Table 2. Bourdon Tube Pressure Ranges and Materials

PRESSURE RANGES ⁽¹⁾		MAXIMUM ALLOWABLE STATIC PRESSURE LIMITS ⁽²⁾				MATERIAL
		Standard		With Optional Travel Stop ⁽³⁾		
Bar	Psig	Bar	Psig	Bar	Psig	
0 to 2.0	0 to 30	2.0	30	3.3	48	316 stainless steel
0 to 4.0	0 to 60	4.0	60	6.6	96	
0 to 7.0	0 to 100	7.0	100	11	160	
0 to 14	0 to 200	14	200	19	280	
0 to 20	0 to 300	20	300	29	420	
0 to 40	0 to 600 ⁽⁴⁾	40	600	50	720	
0 to 70	0 to 1000 ⁽⁴⁾	70	1000	83	1200	
0 to 100	0 to 1500 ⁽⁴⁾	100	1500	115	1650	
0 to 200	0 to 3000	200	3000	230	3300	
0 to 350	0 to 5000	350	5000	380	5500	
0 to 550	0 to 8000	550	8000	550	8000	
0 to 700	0 to 10,000	700	10,000	700	10,000	

1. Range marked on Bourdon tube may be in kPa (1 bar = 100 kPa).
 2. Bourdon tube may be pressured to limit shown without permanent zero shift.
 3. With travel stop set at 110% of the range.
 4. These Bourdon tubes are also available in N05500 nickel alloy for sour service.

Table 3. Bellows Pressure Ranges and Materials

PRESSURE RANGES			MAXIMUM ALLOWABLE STATIC PRESSURE LIMITS ⁽¹⁾			
			Brass Construction		Stainless Steel Construction	
			Bar	Psig	Bar	Psig
Gauge pressure	Vacuum	0 to 150 mbar (0 to 60 inch wc)	1.4	20	---	---
		0 to 340 mbar (0 to 10 inch Hg)	2.8	40	---	---
		0 to 1.0 bar (0 to 30 inch Hg)	2.8	40	6.9	100
Gauge pressure	Compound pressure	75 mbar vac. to 75 mbar (30 inch wc vac. to 30 inch wc)	1.4	20	6.9	100
		500 mbar vac. to 500 mbar (15 inch Hg vac. to 7.5 psig)	2.8	40	6.9	100
		1.0 bar vac. to 1.0 bar (30 inch Hg vac. to 15 psig)	2.8	40	---	---
Gauge pressure	Positive pressure	0 to 150 mbar (0 to 60 inch wc)	1.4	20	---	---
		0 to 250 mbar ⁽²⁾ (0 to 100 inch wc)	1.4	20	---	---
		0 to 350 mbar ⁽³⁾ (0 to 140 inch wc)	2.8	40	---	---
		0 to 0.35 bar (0 to 5 psig)	2.8	40	---	---
		0 to 0.5 bar (0 to 7.5 psig)	2.8	40	---	---
		0 to 0.7 bar (0 to 10 psig)	2.8	40	---	---
		0 to 1.0 bar (0 to 15 psig)	2.8	40	6.9	100
0 to 1.4 bar (0 to 20 psig)	2.8	40	---	---		
0 to 2.0 bar (0 to 30 psig)	2.8	40	6.9	100		
Differential pressure ⁽⁴⁾		0 to 200 mbar (0 to 80 inch wc)	1.4	20	---	---
		0 to 0.7 bar (0 to 10 psi)	2.8	40	---	---
		0 to 1.4 bar (0 to 20 psi)	2.8	40	---	---
		0 to 2.0 bar (0 to 30 psi)	---	---	6.9	100

1. Bellows may be pressured to limit shown without permanent zero shift.
 2. Type 4158K transmitter only.
 3. Except Type 4158K transmitter.
 4. The overrange limit for these sensing elements is a differential pressure equal to the maximum allowable static pressure limit.

Product Bulletin

34.3:4150K
October 2007

4150K/4160K Controllers and Transmitters

Table 4. Supply Pressure Data

OUTPUT SIGNAL		NORMAL OPERATING SUPPLY PRESSURE ⁽¹⁾		MAXIMUM ALLOWABLE SUPPLY PRESSURE TO PREVENT INTERNAL PART DAMAGE	
Bar	Psig	Bar	Psig	Bar	Psig
0.2 to 1.0 or 0 and 1.4	3 to 15 or 0 and 20	1.4	20	3.4	50
0.4 to 2.0 or 0 and 2.4	6 to 30 or 0 and 35	2.4	35	3.4	50

1. If this pressure is exceeded, control may be impaired.

Table 5. Supply and Output Pressure Gauge Ranges

GAUGE SCALE	0.2 to 1.0 Bar (3 to 15 Psig) or 0 and 1.4 Bar (0 and 20 Psig) Output	0.4 to 2.0 Bar (6 to 30 Psig) or 0 and 2.4 Bar (0 and 35 Psig) Output
Single	0 to 30 psig 0 to 2 kg/cm ² 0 to 200 kPa	0 to 60 psig 0 to 4 kg/cm ² 0 to 400 kPa
Dual	0 to 30 psig/0 to 200 kPa	0 to 60 psig/0 to 400 kPa
Triple	0 to 30 psig/0 to 2 kg/cm ² /0 to 2 bar	0 to 60 psig/0 to 4 kg/cm ² /0 to 4 bar

Table 6. Construction Materials

	PART	MATERIAL
In contact with process	Bourdon tube	Stainless steel, or N05500 nickel alloy
	Sensing bellows	Brass or stainless steel
	Pressure block	Stainless steel
	Control tubing (from pressure block to sensing element and to optional process pressure gauge)	Stainless steel
In contact with operating medium	All other interior tubing	Stainless steel
	Exterior tubing	Copper (with or without PVC plastic lining), stainless steel, or synthetic rubber
	Exterior fittings	Brass or stainless steel
	Nozzle and reversing block	Zinc/stainless steel
	Relay springs and spring plate	Steel
	Relay diaphragms	Nitrile/nylon (standard) or polyacrylate/nylon (high-temperature)
	Other metal relay parts, proportional bellows, and exhaust/reset bellows	Zinc/brass or zinc/stainless steel
	Proportional valve assembly	Brass/plated steel or stainless steel
	Reset valve assembly and differential relief valve if used (4160K Series controllers only)	Aluminum/steel/ceramic
Other	O-rings	Nitrile (standard) or fluoroelastomer (high-temperature)
	Gaskets	Chloroprene (standard) or silicone (high-temperature)
	Case and adjustment dial	Aluminum
	Cover	Aluminum, except glass for gauge windows
	Flapper	K93602 nickel alloy
	Control link	N04400 nickel alloy and/or stainless steel
	Flexure and pressure setting adjustment assemblies	Aluminum/steel/stainless steel/plastic
	Calibration adjuster and proportional adjustment assembly	Zinc
O-rings	Nitrile	

4150K/4160K Controllers and Transmitters

Principle of Operation

The key to Wizard II controller operation is the pressure-balanced relay with its yoked double-diaphragm assembly, shown in figure 3 or 4. The relay is connected so that supply pressure bleeds through the fixed orifice before escaping through the nozzle. The nozzle pressure registers on the large relay diaphragm, and loading pressure (controller output) on the small relay diaphragm.

Steady-state sensed process pressure holds the Bourdon tube steady in relation to the nozzle. This allows pressure to escape between the nozzle and beam-flapper assembly at the same rate it bleeds through the orifice.

A change in the process pressure moves the beam and flapper with respect to the nozzle by either expanding or contracting the Bourdon tube arc. An increasing process pressure with direct action (or decreasing pressure with reverse action) produces a nozzle-flapper restriction that increases the loading on the large relay diaphragm. This causes the relay valve to close at the exhaust end and to open at the inlet end. Additional supply pressure flows through the relay chamber to increase the loading pressure on the control valve actuator. A decreasing process pressure with direct action (or increasing pressure with reverse action) produces a nozzle-flapper opening that bleeds off pressure on the large relay diaphragm. This causes the relay valve inlet to close and the exhaust to open, thus exhausting loading pressure from the actuator.

Proportional-Only Controllers

The controller output pressure change feeds back to the proportional bellows, countering the pressure change in the nozzle and equalizing the relay diaphragm pressure differential. The relay valve maintains a new loading pressure according to the change in sensed pressure.

If the proportional valve is wide open (maximum dial setting), all of the controller output pressure change feeds back to the proportional bellows. The more the proportional valve is closed, the more the controller output pressure change bleeds out through the proportional valve exhaust and the less there is to feed back to the proportional bellows. A fully open proportional valve results in a proportional band of 100 percent; closing the proportional valve reduces the proportional band.

Proportional-Plus-Reset Controllers

Additionally, all 4160K Series controllers have a two-way reset restriction valve that channels proportional pressure into a reset bellows to oppose the proportional bellows action. The action of this reset pressure occurs on a delayed basis, and the reset valve can be adjusted to vary the time of delay.

Anti-Reset Windup

The Type 4160KF and 4162KF controllers have an adjustable and reversible differential relief valve to provide anti-reset windup. As shown in figure 4, the proportional pressure registers rapidly on the spring side of the relief valve diaphragm as well as in the proportional bellows. Reset pressure registers slowly on the opposite side of the relief valve diaphragm. As long as controller output pressure changes are slow enough for normal proportional and reset action, the relief valve spring keeps the relief valve diaphragm from opening. However, a large or rapid decrease in controller output pressure causes the relay to rapidly exhaust loading pressure from the control element, and also from the proportional system and spring side of the relief diaphragm. If this decrease on the spring side of the diaphragm is greater than the relief valve spring setting, the diaphragm will move off the relief valve orifice and permit the reset pressure on the opposite side of the relief valve diaphragm to bleed rapidly into the proportional system. The anti-reset windup action also can be reversed to relieve with an increasing proportional pressure.

Construction Features

Rugged Service Capability

The case and cover are made of weather resistant, die-cast aluminum. Stainless steel tubing and fitting materials provide the capability for operation in ammonia and similar corrosive service conditions. Optional materials for relay diaphragms and other soft parts permit operation at ambient temperatures up to 93°C (200°F).

Low-Pressure Precision

Bellows sensing constructions provide accuracy in low-pressure, vacuum, or compound ranges. Two sensing bellows are used where an important variable is the difference between two sensed pressures.

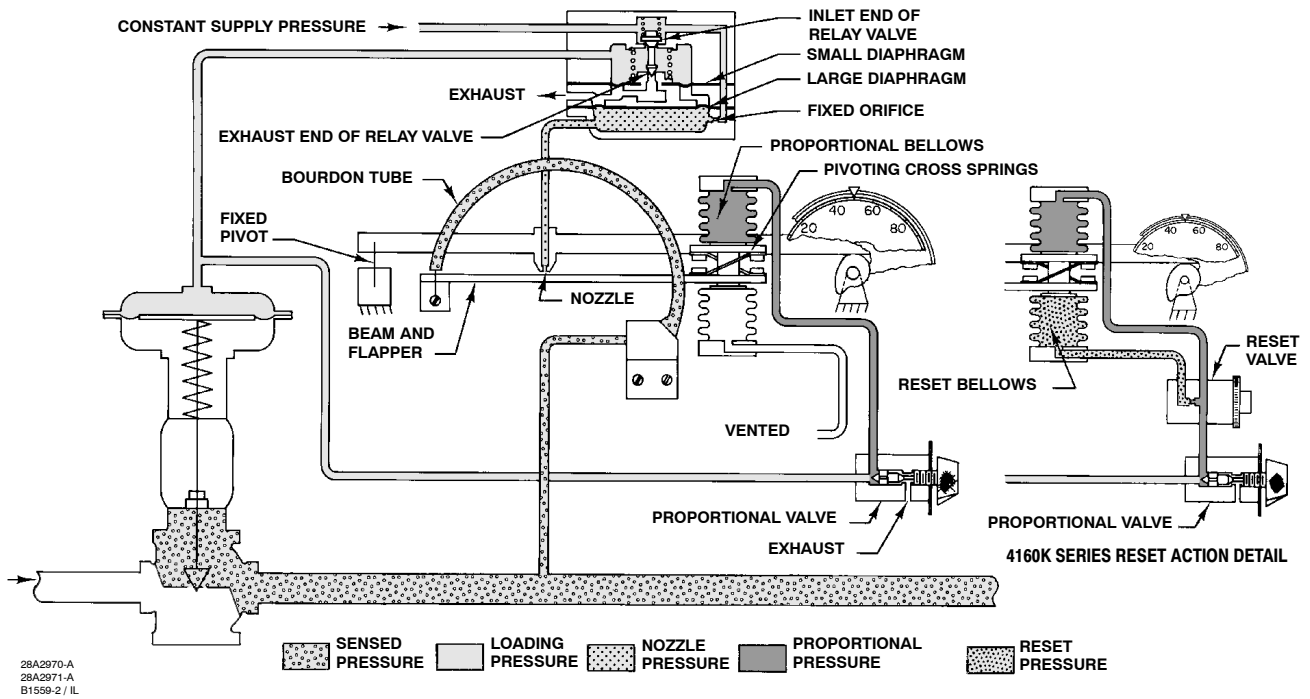

Figure 3. Operational Schematic of Direct-Acting Bourdon Tube Controller on Pipeline Pressure Service

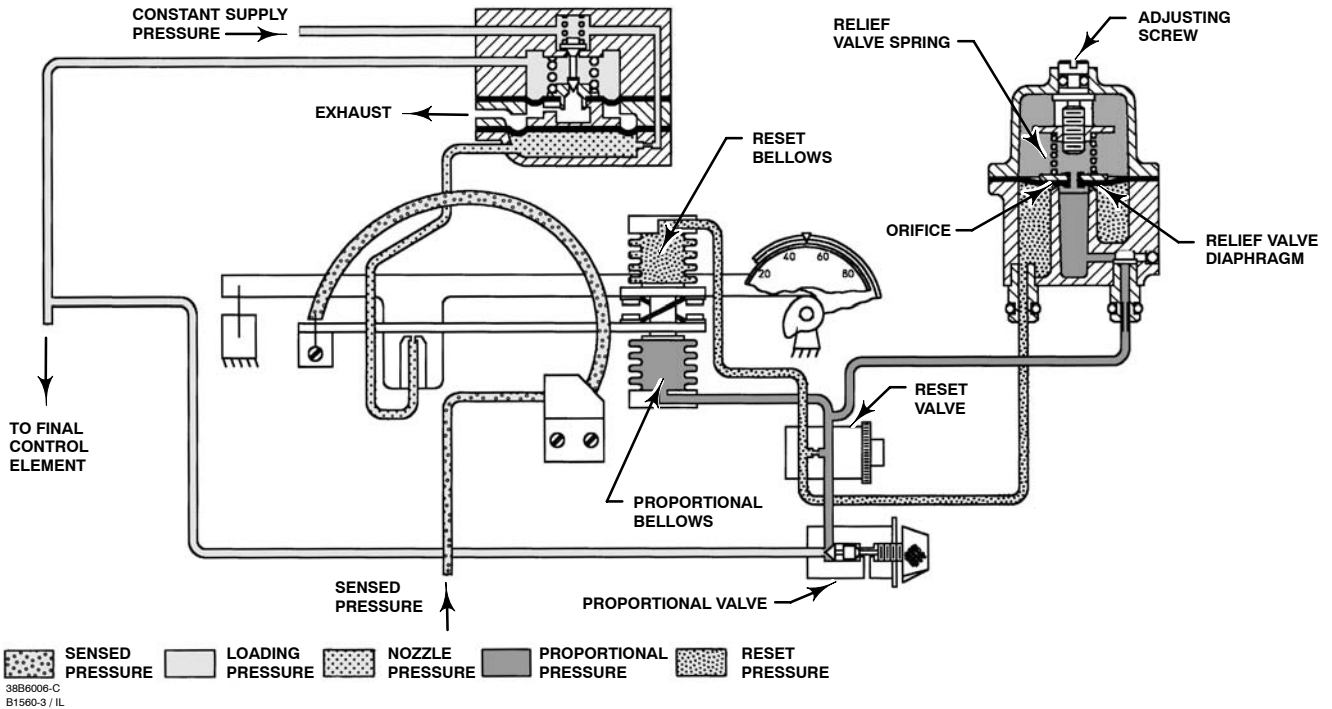
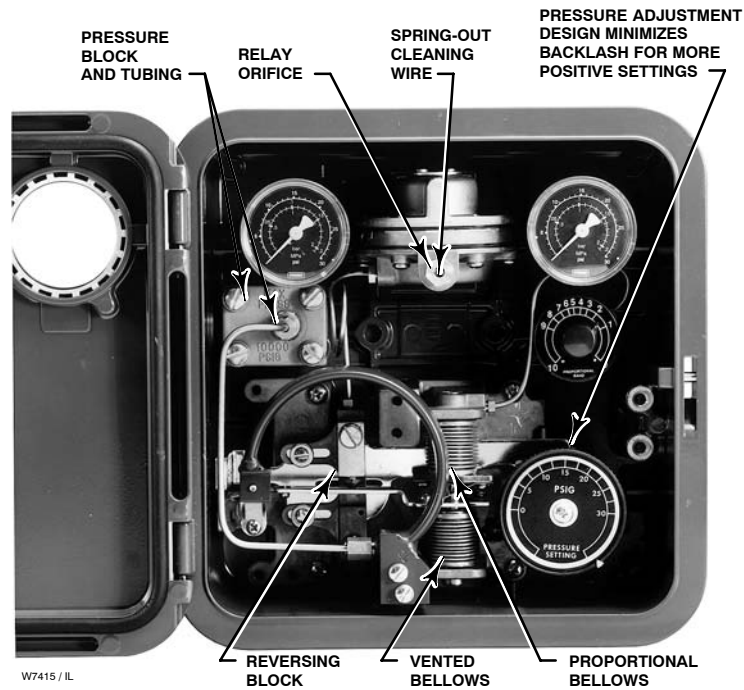
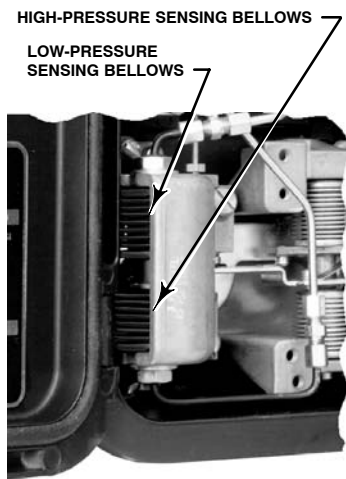

Figure 4. Operational Schematic of Type 4160KFR Controller

4150K/4160K Controllers and Transmitters



DIRECT-ACTING TYPE 4150K CONTROLLER (ALSO REPRESENTATIVE OF TYPE 4150KS AND 4157K BOURDON TUBE CONSTRUCTIONS)



TYPE 4154K AND 4155K DIFFERENTIAL BELLOWS DETAILS

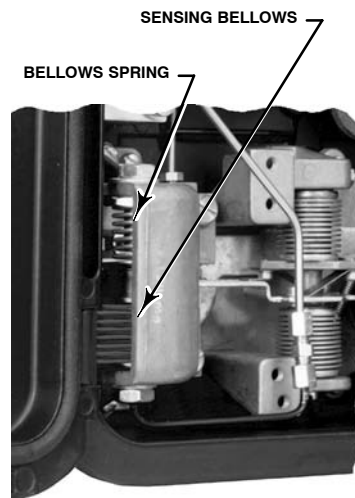

TYPE 4152K, 4152KS AND 4158K BELLOWS DETAILS

Figure 5. 4150K Series Constructions

4150K/4160K Controllers and Transmitters

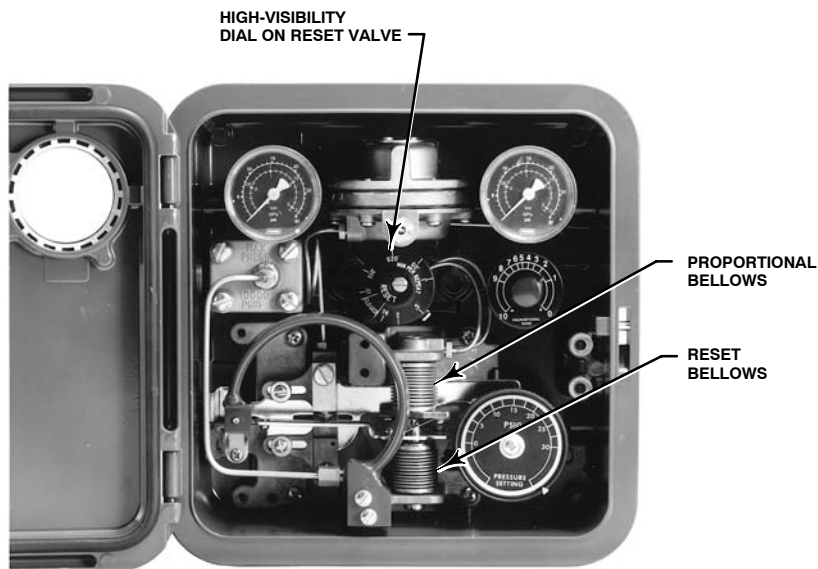

W7414 / IL

DIRECT-ACTING TYPE 4160K CONTROLLER



W7417 / IL

TYPE 4160KF AND 4162KF DIFFERENTIAL RELIEF VALVE DETAIL

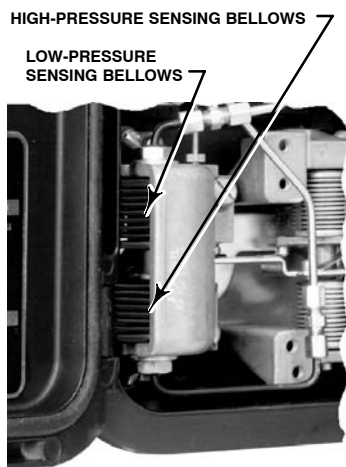

W5458-1 / IL

TYPE 4164K DIFFERENTIAL BELLOWS DETAILS

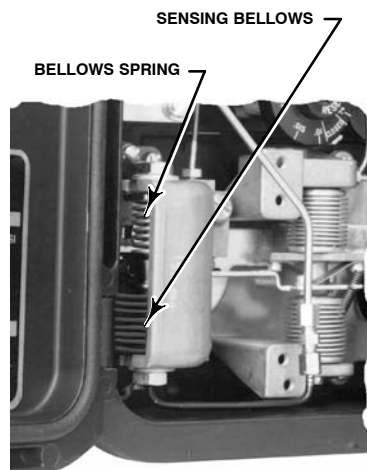

W3550-1 / IL

TYPE 4162K BELLOWS DETAILS

Figure 6. 4160K Series Constructions

4150K/4160K Controllers and Transmitters

Table 7. Optional Process Pressure Gauges

Sensing Element	Gauge Range ⁽¹⁾	
Bourdon tube	Positive pressure	0 to 30 psig ⁽²⁾ 0 to 60 psig 0 to 160 psig
		0 to 300 psig ⁽²⁾ 0 to 600 psig 0 to 1000 psig
Bellows	Positive pressure	0 to 30 psig ⁽²⁾

1. Consult your Emerson Process Management™ sales office for gauges in other units.
2. Also available in stainless steel trim.

Easy Conversion From Proportional To On-Off Control

The Type 4150KS controller provides on-off rather than proportional control. This construction has the same parts as the comparable Type 4150K controller. However, the proportional bellows is connected so that feedback pressure pushes the beam and flapper in the same direction as caused by the sensed pressure change. This reinforcement completely opens the relay valve either to full supply pressure or to full exhaust, allowing no in-between throttling.

To change from a proportional to on-off controller, or vice versa, just reverse the tubing connection at the bellows frame on top of the beam and flapper as shown in figure 7.

Anti-Reset Windup

The anti-reset windup capability of the Type 4160KF and 4162KF controllers provides quick equalization of reset and proportional pressures. This capability reduces overshoot and the time required for a system to return to the pressure setting after large changes in sensed pressure. This feature is useful when slow reset and broad proportional band settings are used.

The differential relief valve has a range of 0.14 to 0.4 bar (2 to 7 psig) and, unless ordered otherwise, is set by the factory to relieve at a 0.3 bar (5 psi) difference between proportional and reset pressures.

Manual Backup

As shown in figure 8, a 670 or 671 Series panel-mounted loading regulator with changeover valve permits switching to an alternate loading

pressure, if a Wizard II controller experiences supply pressure failure or other malfunction.

Continuous Indication of Process Pressure

Replacing the supply pressure gauge on a controller or transmitter by a process pressure gauge permits indicating process pressure in one of the ranges shown in table 7. To obtain a supply pressure indication, install a gauge on the supply regulator. The process pressure gauge must be specially ordered and comes with brass trim standard in all ranges and stainless steel trim optional in some ranges. Adding a process pressure gauge in the field also requires a special control pressure block. A process pressure gauge can not be added to controllers or transmitters that use a differential bellows for sensing process pressure.

Bourdon Tube Protection

All Bourdon tube constructions are available with one or both of the following protective devices:

- **Barrier Protector for Corrosive or Clogging Process Fluids**—A sealed and fluid-filled barrier (described in a separate bulletin) may be installed between the process and the Bourdon tube. The barrier fluid transmits sensed pressure on a one-to-one basis into the Bourdon tube.

- **Travel Stop for Bourdon Tube**—The stop limits Bourdon tube overtravel when momentary surges in the sensed pressure exceed the Bourdon tube rating. Although it does not permit accurate control or transmission of a pressure higher than the upper range limit listed in table 2, this stop does permit Bourdon tube overpressuring to the maximum static pressure shown in table 2 without damage.

Installation

A Wizard II controller or transmitter normally comes installed on a final control element or indicating device or equipped for separate surface or pipestand mounting. Usually, a control valve with just a controller or transmitter and one supply regulator has the controller/transmitter and regulator yoke-mounted on opposite sides of the actuator as shown in figure 9. Nipple mounting of the supply regulator (if desired) is available. Specify such mounting if the opposite yoke boss of an actuator will be occupied by a positioner.

Product Bulletin

34.3:4150K
October 2007

4150K/4160K Controllers and Transmitters

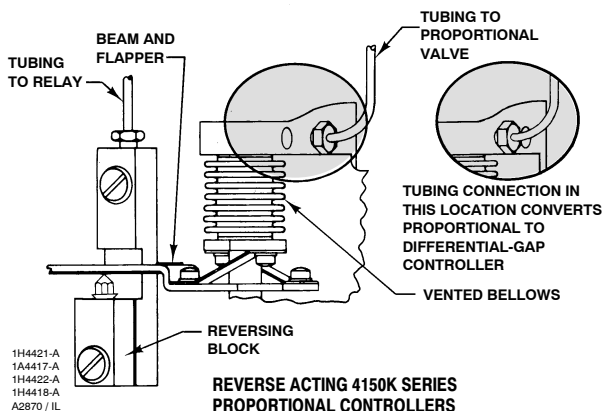
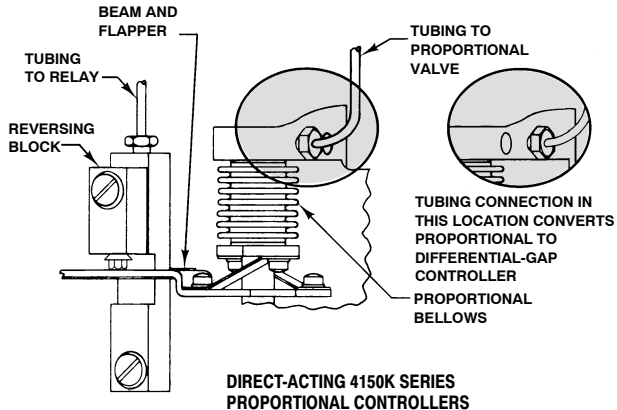

Figure 7. Conversion from Direct to Reverse Action or Proportional to On-Off Control

Install the controller or transmitter so that the vent points down. Figure 10 illustrates the vent location, the location of all case connections, dimensions, and mounting information.

Ordering Information

Application

When ordering, specify:

1. Type of service, such as pressure reduction or pressure relief, throttling or on-off.
2. Composition, pressure, and temperature of measured variable(s).
3. Type number, orientation, and other applicable descriptions of control or indicating device(s).

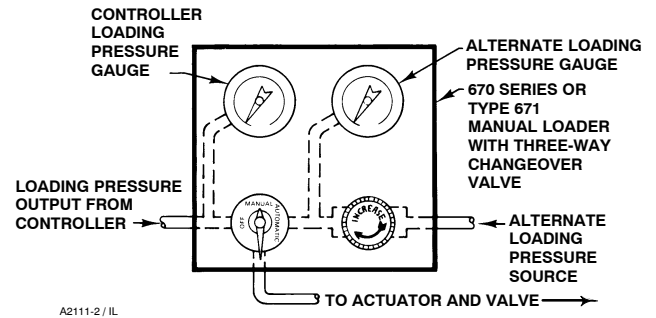

Figure 8. Schematic of Manual Backup Changeover Hookup for Wizard® II Controller

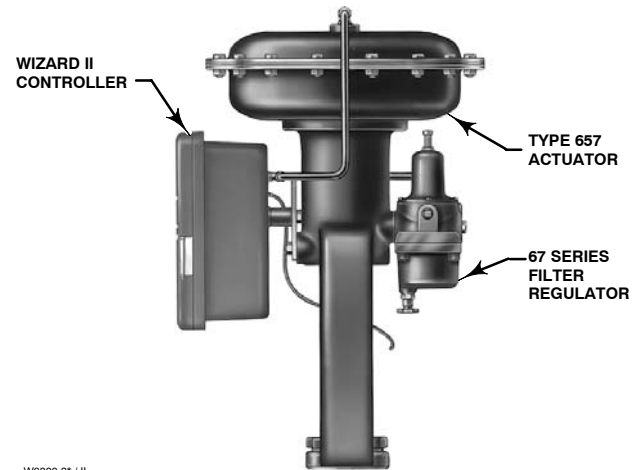

Figure 9. Typical Yoke Mounting

Construction

Refer to the Specifications and the Construction Features sections. Review the description for each specification, construction feature, and in the referenced tables. Specify the desired selection whenever there is a choice.

Always specify the complete type number (including the R suffix for reverse action) of the Wizard II controller or transmitter, supply pressure regulator, and other desired equipment. On controllers with anti-reset windup, specify whether the differential relief valve is to relieve with falling or rising output.

4150K/4160K Controllers and Transmitters

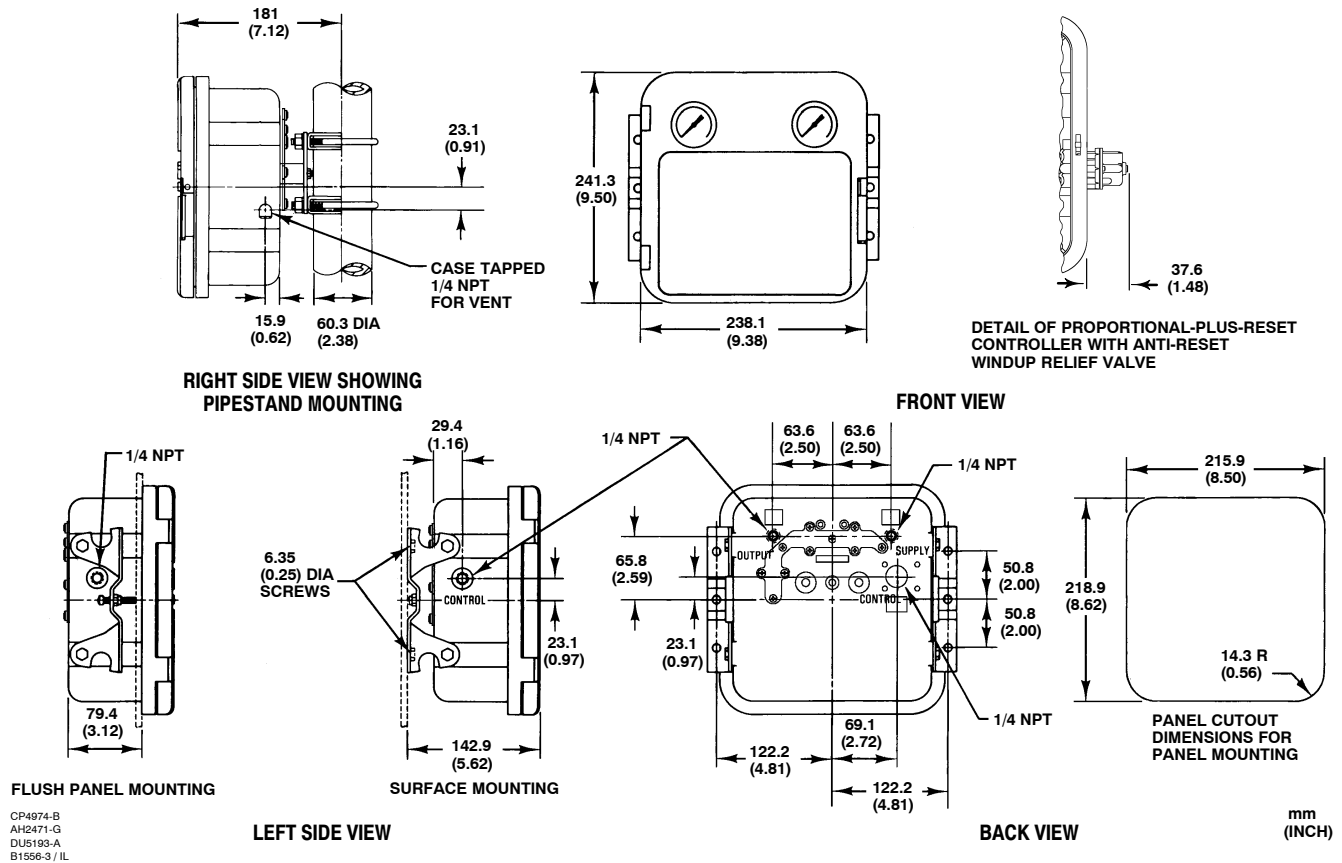

Figure 10. Dimensions

Note

Neither Emerson, Emerson Process Management, nor any of their affiliated entities assumes responsibility for the selection, use, and maintenance of any product. Responsibility for the selection, use, and maintenance of any product remains with the purchaser and end-user.

Wizard and Fisher are marks owned by Fisher Controls International LLC, a member of the Emerson Process Management business division of Emerson Electric Co. Emerson Process Management, Emerson, and the Emerson logo are trademarks and service marks of Emerson Electric Co. All other marks are the property of their respective owners.

The contents of this publication are presented for informational purposes only, and while every effort has been made to ensure their accuracy, they are not to be construed as warranties or guarantees, express or implied, regarding the products or services described herein or their use or applicability. We reserve the right to modify or improve the designs or specifications of such products at any time without notice.

Neither Emerson, Emerson Process Management, nor any of their affiliated entities assumes responsibility for the selection, use and maintenance of any product. Responsibility for the selection, use and maintenance of any product remains with the purchaser and end-user.

Emerson Process Management

Marshalltown, Iowa 50158 USA
Cernay 68700 France
Sao Paulo 05424 Brazil
Singapore 128461

www.Fisher.com

