

# Fisher® 3582 Series and 3582i Positioners and 582i Electro-Pneumatic Converter

Fisher® 3582 Series pneumatic valve positioners, shown in figure 1, and 3582i electro-pneumatic valve positioners, shown in figure 2, are used with diaphragm-actuated, sliding-stem control valve assemblies. The pneumatic valve positioners receive a pneumatic input signal from a control device and modulate the supply pressure to the control valve actuator, providing an accurate valve stem position that is proportional to the pneumatic input signal.

3582NS positioners are designed for nuclear power applications. The 3582NS construction includes materials that provide superior performance at elevated temperature and radiation levels. The O-rings are EPDM (ethylene propylene) and the diaphragms are EPDM/meta-aramid. EPDM demonstrates superior temperature capability and shelf life over nitrile.

## Note

**Use a clean, dry, oil-free air supply with instruments containing EPDM components. EPDM is subject to degradation when exposed to petroleum-based lubricants.**

The meta-aramid diaphragm fabric demonstrates improved strength retention at elevated temperature and radiation conditions.

Under the 10CFR50, Appendix B, quality assurance program, the 3582NS positioner is qualified commercial grade dedicated. These can be supplied as 10CFR, Part 21 items.

The 3582i electro-pneumatic valve positioner consists of a Fisher 582i electro-pneumatic converter installed on a 3582 pneumatic valve positioner. The 3582i provides an accurate valve stem position that is proportional to a DC current input signal.



W5498-1 / IL

Figure 1. Typical Fisher® 3582 Series Pneumatic Valve Positioner with Actuator and Valve

The 582i electro-pneumatic converter, shown in figure 5, is a modular unit that can be installed at the factory or in the field.

The converter receives a DC current input signal and provides a proportional pneumatic output signal through a nozzle/flapper arrangement. The pneumatic output signal provides the input signal to the pneumatic positioner, eliminating the need for a remote mounted transducer.

## Note

**Upgrading an existing 3582 Series unit by field installation of a 582i electro-pneumatic converter may require changing the existing positioner mounting and the input signal range. Contact your Emerson Process Management sales office when planning an upgrade.**



## Specifications

### Available Configurations

Refer to Type Number Description

### Input Signal

#### For 3582 Series

■ 0.2 to 1.0 bar (3 to 15 psig), ■ 0.4 to 2.0 bar (6 to 30 psig), or ■ split range, see table 2.

#### For 3582i only

4-20 mA DC constant current with 30 VDC maximum compliance voltage, can be split range, see table 2.

### Equivalent Circuit

#### For 3582i only

120 ohms shunted by three 5.6-volt zener diodes, see figure 3

### Output Signal

**Type:** Pneumatic pressure as required by actuator up to 95 percent of maximum supply

**Action:** Field-reversible between ■ direct and ■ reverse within the pneumatic valve positioner

### Supply Pressure<sup>(1)</sup>

**Recommended:** 0.3 bar (5 psi) above actuator requirement

**Maximum:** 3.4 bar (50 psig) or pressure rating of actuator, whichever is lower

### Supply Medium

Air or natural gas<sup>(2)</sup>

**The 3582i positioner is not approved for use with natural gas as the supply medium**

### Maximum Input Bellows Pressure Rating<sup>(1)</sup>

2.4 bar (35 psig)

### Maximum Steady-State Air Consumption<sup>(3)</sup>

#### For 3582 Series:

1.4 bar (20 psig) Supply: 0.38 normal m<sup>3</sup>/hr (14.0 scfh)

2.0 bar (30 psig) Supply: 0.48 normal m<sup>3</sup>/hr (18.0 scfh)

2.4 bar (35 psig) Supply: 0.54 normal m<sup>3</sup>/hr (20.0 scfh)

#### For 3582i Only:

1.4 bar (20 psig) Supply: 0.46 normal m<sup>3</sup>/hr (17.2 scfh)

2.0 bar (30 psig) Supply: 0.57 normal m<sup>3</sup>/hr (21.4 scfh)

2.4 bar (35 psig) Supply: 0.64 normal m<sup>3</sup>/hr (23.8 scfh)

### Maximum Supply Air Demand<sup>(3)</sup>

#### For 3582 Series and 3582i:

1.4 bar (20 psig) Supply: 4.4 normal m<sup>3</sup>/hr (164.5 scfh)

2.0 bar (30 psig) Supply: 6.7 normal m<sup>3</sup>/hr (248.5 scfh)

2.4 bar (35 psig) Supply: 7.7 normal m<sup>3</sup>/hr (285.5 scfh)

### Performance

#### For 3582 Series

**Independent Linearity:** ±1 percent of output signal span

**Hysteresis:** 0.5 percent of span

#### For 3582i Only

**Independent Linearity:** ±2 percent of output signal span

**Hysteresis:** 0.6 percent of span

### Electromagnetic Compliance for 582i electro-magnetic converter

Meets EN 61326-1 (First Edition)

Immunity—Industrial locations per Table 2 of the EN 61326-1 standard. Performance is shown in table 1 below.

Emissions—Class A

ISM equipment rating: Group 1, Class A

**Note: Electromagnetic Compatibility also applies to the 3582i positioner**

### For 3582 Series and 3582i

**Open Loop Gain (Output Signal):**

■ 100 in the range of 0.2 to 1.0 bar (3 to 15 psig)

■ 55 in the range of 0.4 to 2.0 bar (6 to 30 psig)

### Operating Influences

**Supply Pressure, For 3582 Series Units:** Valve travel changes less than 1.67 percent per bar (0.25 percent per 2 psi) change in supply pressure

**Supply Pressure, For 3582i Units:** Valve travel changes less than 3.62 percent per bar (1.5 percent per 2 psi) change in supply pressure

- continued -

Specifications (Continued)

Operative Temperature Limits<sup>(1)</sup>

**Standard Construction, For 3582 Series and 3582i Units:** -40 to 71°C (-40 to 160°F)  
**3582NS Units:** -40 to 82°C (-40 to 180°F) with EPDM elastomers  
**High-Temperature Construction<sup>(4)</sup>, For 3582A and C Only:** -18 to 104°C (0 to 220°F) without gauges

Electrical Classification for 582i



Intrinsic Safety, Explosion proof, Type n  
Dust-Ignition proof, DIV 2,



Intrinsic Safety, Explosion proof, Type n,  
Non-incendive, Dust-Ignition proof,

ATEX Intrinsic Safety, Type n, Explosion proof  
(Gas Atmospheres Only)

IECEX Intrinsic Safety, Type n, Explosion proof  
(Gas Atmospheres Only)

SAA Intrinsic Safety, Flameproof, Type n



Intrinsic Safety, Flameproof



Intrinsic Safety, Flameproof

Refer to tables 5, 6, 7, 8, 9, 10, and 11 for additional information

**Note: These classifications also apply to the 3582i positioner**

Housing Classification for 582i

CSA Type 3 Encl., NEMA 3, IP54 per IEC 60529; Mount instrument with vent on the side or the bottom if weatherproofing is a concern.

**Note: These classifications also apply to the 3582i positioner**

Hazardous Area Classifications for 3582

3582 Series valve positioners comply with the requirements of ATEX Group II Category 2 Gas and Dust

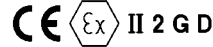

**Note: This rating does not apply to the 3582i positioner**

Construction Materials

Refer to table 3

Pressure Gauges

40 mm (1.5 inch) diameter with plastic case and brass connection  
■ triple scale (PSI, MPa, and bar) or  
■ dual scale (PSI and kg/cm<sup>2</sup>)

Pressure Connections

1/4 NPT internal

Electrical Connection for 3582i

1/2-14 NPT conduit connection

Maximum Valve Stem Travel

105 mm (4.125 inches); adjustable to obtain lesser travel with standard input signal

Characterized Cams

See characterized cams section

Approximate Weight

**3582 Series Units:** 2.5 kg (5-1/2 pounds)  
**3582i:** 3.6 kg (8 pounds)

Options

- Instrument, output, and supply pressure gauges; automotive tire valves; or pipe plugs (see Type Number Description section)
- Bypass valve (only for direct-acting, 3582 Series units using a full input signal range)
- Characterized cams B and C ■ Connectors for diagnostic testing ■ High vibration

NOTE: Specialized instrument terms are defined in ANSI/ISA Standard 51.1 - Process Instrument Terminology.  
1. The pressure and temperature limits in this document and any applicable standard or code limitation should not be exceeded.  
2. Natural gas should contain no more than 20 ppm of H<sub>2</sub>S.  
3. Normal m<sup>3</sup>/hr--normal cubic meters per hour (0°C and 1.01325 bar absolute); Scfh--standard cubic feet per hour (60°F and 14.7 psia).  
4. Not available with bypass or pressure gauges.

Table 1. Fisher® 582i Electro-Pneumatic Converter<sup>(1)</sup> EMC Summary Results—Immunity

PORT	PHENOMENON	BASIC STANDARD	TEST LEVEL	PERFORMANCE CRITERIA <sup>(2)</sup>
Enclosure	Electrostatic Discharge (ESD)	IEC 61000-4-2	4 kV contact 8 kV air	A
	Radiated EM field	IEC 61000-4-3	80 to 1000 MHz @ 10V/m with 1 kHz AM at 80% 1400 to 2000 MHz @ 3V/m with 1 kHz AM at 80% 2000 to 2700 MHz @ 1V/m with 1 kHz AM at 80%	A
	Rated power frequency magnetic field	IEC 61000-4-8	60 A/m at 50 Hz	A
I/O signal/control	Burst (fast transients)	IEC 61000-4-4	1 kV	A
	Surge	IEC 61000-4-5	1 kV (line to ground only, each)	B
	Conducted RF	IEC 61000-4-6	150 kHz to 80 MHz at 3 Vrms	A

Specification limit = ±1% of span  
 1. The information contained in the table also applies to the 3582i positioner.  
 2. A = No degradation during testing. B = Temporary degradation during testing, but is self-recovering.

Table 2. Split-Range Capabilities

3582 SERIES POSITIONERS				
Split	0.2 to 1.0 Bar or 3 to 15 Psig Input Signal		0.4 to 2.0 Bar or 6 to 30 Psig Input Signal	
	Bar	Psig	Bar	Psig
Two-way	0.2 to 0.6	3 to 9	0.4 to 1.2	6 to 18
	0.6 to 1.0	9 to 15	1.2 to 2.0	18 to 30
Three-way	0.2 to 0.5	3 to 7	0.4 to 0.9	6 to 14
	0.5 to 0.7	7 to 11	0.9 to 1.5	14 to 22
	0.7 to 1.0	11 to 15	1.5 to 2.0	22 to 30

3582i POSITIONER	
Split	4-20 Milliampere Input Signal
Two-way	4 to 12 12 to 20
	4 to 9.3 9.3 to 14.7 14.7 to 20
Three-way	

Table 3. Construction Materials

PART	MATERIAL	
	Standard	High-Temperature
<b>Positioner</b>		
Case	Low copper aluminum alloy	---
Cover	Impact-resistant plastic	---
Bellows	Phosphor bronze	---
O-Ring		
All 3582 except 3582NS	Nitrile	Fluorocarbon
3582NS	EPDM	---
Connectors for Diagnostic Testing	Stainless Steel or Brass	---
<b>Relay</b>		
Castings	Aluminum	---
Diaphragms		
All 3582 except 3582NS	Nitrile/Polyester	Polyacrylate-Nylon
3582NS	EPDM/meta-aramid	---
O-Rings		
All 3582 except 3582NS	Nitrile	Fluorocarbon
3582NS	EPDM	---
Gaskets	Nitrile/polyester	Polyacrylate-Nylon
<b>582i Converter</b>		
Case and Cover	Low copper aluminum alloy	---
O-Rings	Nitrile	---



W8152 / IL

Figure 2. Fisher® 3582i Electro-Pneumatic Valve Positioner

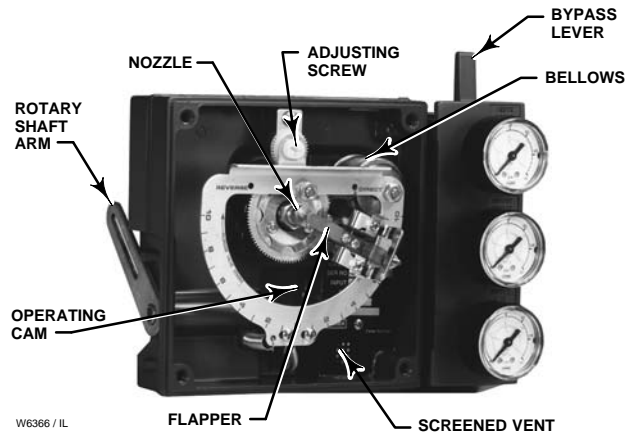

W6366 / IL

Figure 4. Fisher® 3582 Pneumatic Valve Positioner Mechanism

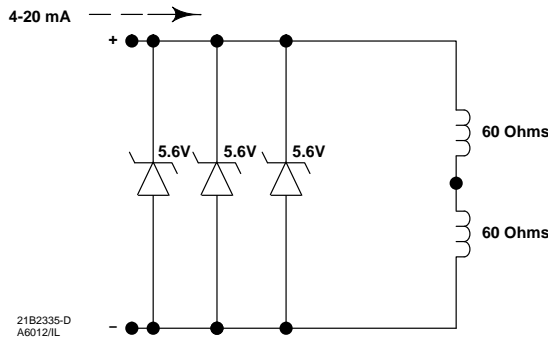

21B2335-D  
A6012/IL

Figure 3. Equivalent Circuit

## Features

- Versatile Modular Design**—The 3582 Series unit can be upgraded in the field to an electro-pneumatic 3582i by replacing the gauge block with the 582i electro-pneumatic converter (figure 5) assembly. The converter assembly attaches to the positioner case, providing a cost-effective conversion. Thus, in the field, 3582 Series units can be upgraded from pneumatic to electronic to match new control strategies.

### Note

**Upgrading an existing 3582 Series unit by field installation of a 582i electro-pneumatic converter may require changing the existing positioner mounting and the input signal range. Contact your Emerson Process Management sales office when planning an upgrade.**

- Accurate, Efficient, Vibration-Resistant Operation**—The 3582 Series and the 3582i positioners offer a field-proven positioner design which is accurate, fast-responding and able to withstand the vibrations of most plant environments. Low steady-state air consumption contributes to efficient operation.

- Rangeability**—Both the 3582 Series and the 3582i positioners provide split range capabilities. The range of the adjustable zero and span permits the use of all standard input signals including split ranges.

- Simplified Spare Parts Inventories**—Because units from one positioner family can be used in a variety of control applications, basic spare parts inventory requirements are simplified and fewer spare parts are needed to support a plant-wide positioner applications base.

- Easy Positioner Adjustments**—With the cover removed, as shown in figure 4, zero and span adjustments are easily accessible and can be made with a screw driver.

- Stable Operation**—Changes in supply pressure and valve load have minimal effect on positioner operation.

- Corrosion Resistance**—Case, components, and gasket materials withstand harsh environments. Positioner bleed air purges internal parts for additional protection.

# 3582 Series



Figure 5. Fisher® 582i Electro-Pneumatic Converter

- **Field Reversible**—Simple adjustments permit switching between direct and reverse action.

- **Control Valve Diagnostic Testing**

**Capability**—To support diagnostic testing of valve/actuator/positioner packages with the FlowScanner™ valve diagnostic system, connectors, piping, and other hardware can be installed between the 3582 Series or 3582i and the actuator.

## Type Number Description

**3582**—Pneumatic valve positioner with bypass and instrument, supply, and output pressure gauges.

**3582A**—Pneumatic valve positioner without bypass and without pressure gauges.

**3582C**—Pneumatic valve positioner without bypass and with automotive tire valves instead of pressure gauges.

**3582D**—Pneumatic valve positioner with bypass and with automotive tire valves instead of pressure gauges.

**3582G**—Pneumatic valve positioner without bypass and with instrument, supply, and output pressure gauges.

**3582NS**—Pneumatic valve positioner for nuclear service applications with or without bypass and with automotive tire valves instead of pressure gauges.

**3582i**—Electro-pneumatic valve positioner without bypass; with 582i converter; and with: ■ supply and output pressure gauges, ■ automotive tire valves, or ■ pipe plugs.

**582i**—Electro-pneumatic converter with: ■ supply and output pressure gauges, ■ automotive tire valves, or ■ pipe plugs. Used for conversion of a 4-20 milliampere input signal to a 0.2 to 1.0 bar (3 to 15 psig) input signal for the pneumatic valve positioner.

**83L**—Pneumatic relay included as part of both the 3582 Series positioners and the 3582i positioner.

## Principle of Operation

The 3582 Series (3582, 3582NS and 3582A, C, D, and G pneumatic valve positioners) accept a pneumatic input signal from a control device. The operational schematic in figure 6 depicts the direct-acting pneumatic valve positioner.

Supply pressure is connected to the 83L relay. A fixed restriction in the relay limits flow to the nozzle so that when the flapper is not restricting the nozzle, air can bleed out faster than it is being supplied.

The input signal from the control device is connected to the bellows. When the input signal increases, the bellows expands and moves the beam. The beam pivots about the input axis moving the flapper closer to the nozzle. The nozzle pressure increases and, through relay action, increases the output pressure to the diaphragm actuator. The increased output pressure to the actuator causes the actuator stem to move downward. Stem movement is fed back to the beam by means of a cam. As the cam rotates, the beam pivots about the feedback axis to move the flapper slightly away from the nozzle. The nozzle pressure decreases and reduces the output pressure to the actuator. Stem movement continues, backing the flapper away from the nozzle, until equilibrium is reached.

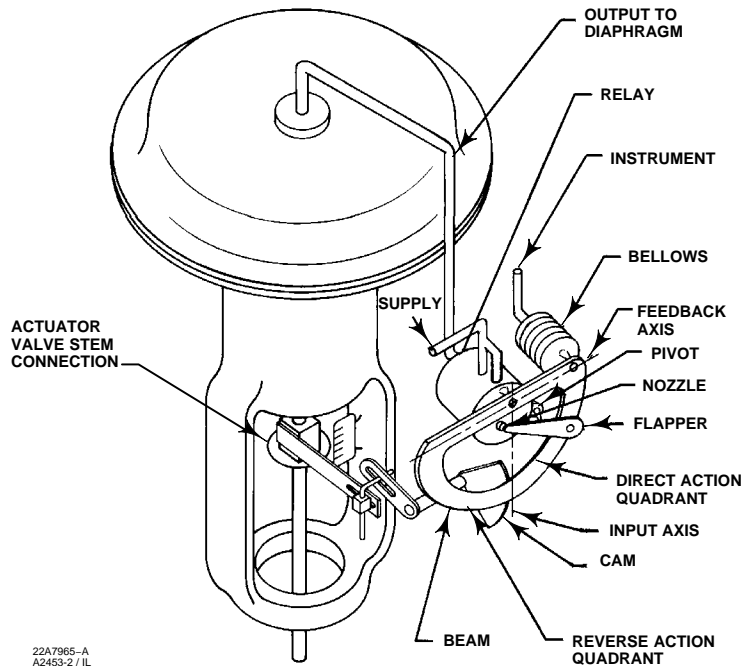

Figure 6. Fisher® 3582 Series Positioner Schematic Diagram

When the input signal decreases, the bellows contracts (aided by an internal range spring) and the beam pivots about the input axis to move the flapper away from the nozzle. Nozzle pressure decreases and the relay permits the release of diaphragm casing pressure to atmosphere. The actuator stem moves upward. Through the cam, stem movement is fed back to the beam to reposition the flapper closer to the nozzle. When equilibrium conditions are obtained, stem movement stops and the flapper is positioned to prevent any further decrease in diaphragm case pressure.

The principle of operation for reverse acting units is similar except that as the input signal increases, the diaphragm casing pressure is decreased. Conversely, a decreasing input signal causes an increase in the pressure to the diaphragm casing.

As shown in figure 7, the 3582i electro-pneumatic positioner accepts a DC current input signal provided to the 582i electro-pneumatic converter attached to the positioner. The 582i provides the

pneumatic input signal pressure used by the pneumatic positioner.

### Characterized Cams

Three cams are available for the 3582 Series valve positioners. A linear cam (cam A) is supplied with the unit. Two characterized cams (cams B and C) are available as options. Figure 8 shows the resultant stem travel due to an incremental instrument pressure change for each cam. When the linear cam is the operating cam, there is a linear relationship between an incremental input signal change and valve travel, and the flow characteristic of the valve is that of the control valve. When either characterized cam is the operating cam, the relationship between an incremental input signal change and valve travel changes thereby modifying the valve flow characteristics. Figure 9 shows how the characteristic is modified for an equal percentage valve. Figure 10 shows how the characteristic is modified for a linear valve.

Since the 3582 Series positioner mounts the same way on either direct-acting or reverse-acting diaphragm actuators, the cams are reversible.

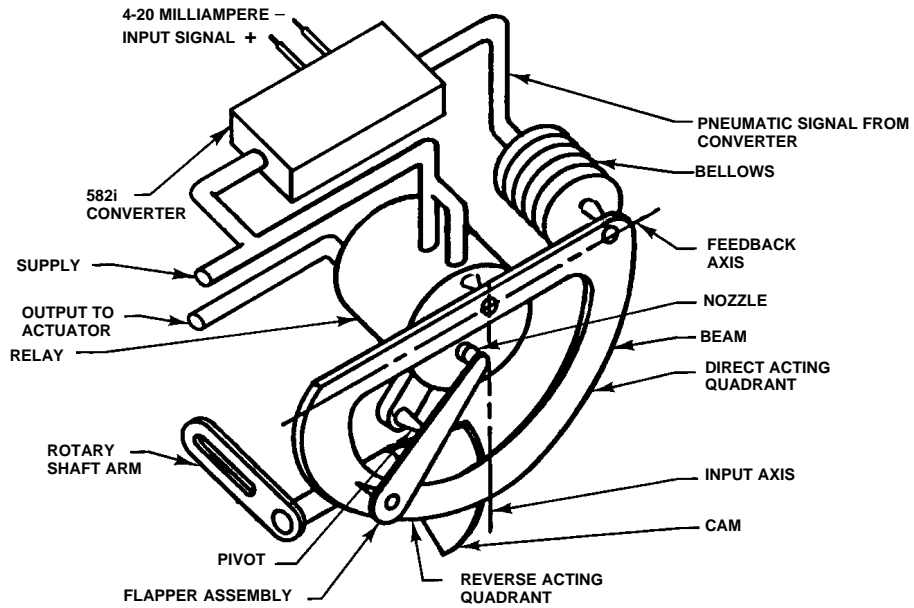

A4818-2/IL

Figure 7. Fisher® 3582i Positioner Schematic Diagram

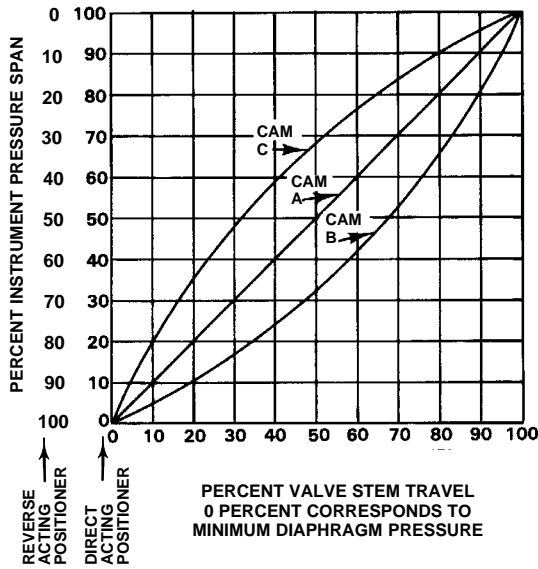

CK4832-A  
A1413/IL

Figure 8. Instrument Pressure Versus Valve Travel

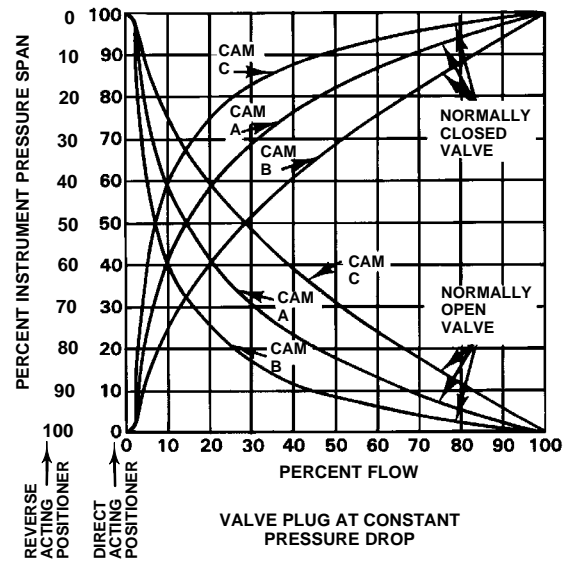

CK4835-A  
A1415-1/IL

Figure 9. Equal Percentage Valve Flow Characteristics as Modified by Various Cams

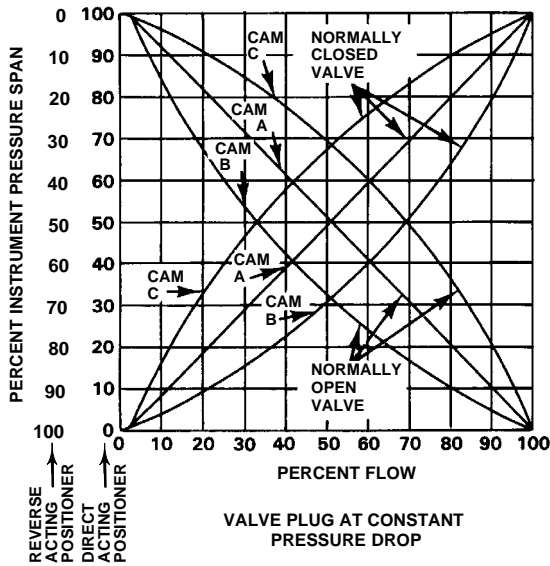

CK4833-A  
A1414 / IL

Figure 10. Linear Valve Flow Characteristics as Modified by Various Cams

2. Maximum supply pressure available
3. Direct or reverse acting
4. Valve stroke in inches; actuator type and size
5. Initial cam set-up (cam A, B, or C)
6. Input signal
7. Supply pressure regulator and test pressure gauge.
8. Connectors for diagnostic testing, if required.

### Installation

Figure 11 shows a typical positioner mounting for a direct- or reverse-acting actuator. Positioner overall dimensions and connections are shown in figure 11 and table 4.

### Ordering Information

When ordering, please specify the product application and construction:

#### Application

1. Positioner type number. When ordering a 3582i electro-pneumatic positioner, specify:
  - supply and output pressure gauges,
  - automotive tire valves, or
  - pipe plugs.

### Construction

Refer to the specifications. Carefully review each specification; indicate your choice whenever a selection is offered.

#### Note

**Neither Emerson, Emerson Process Management, nor any of their affiliated entities assumes responsibility for the section, use, or maintenance of any product. Responsibility for the selection, use, and maintenance of any product remains with the purchaser and end-user.**

Table 4. Dimensions

STEM TRAVEL		X					
		9.5 mm (0.375 inch) Stem		12.7 mm (0.50 inch) Stem		19.1 mm (0.75 inch) Stem	
mm	Inch	mm	Inch	mm	Inch	mm	Inch
29 or less	1.125 or less	81	3.19	87	3.44	100	3.94
38	1.50	90	3.56	97	3.81	109	4.31
51	2	102	4.00	108	4.25	121	4.75
64	2.50	113	4.44	119	4.69	132	5.19
76	3	124	4.88	130	5.12	143	5.62
89	3.50	135	5.31	141	5.56	154	6.06
102	4	146	5.75	152	6.00	165	6.50

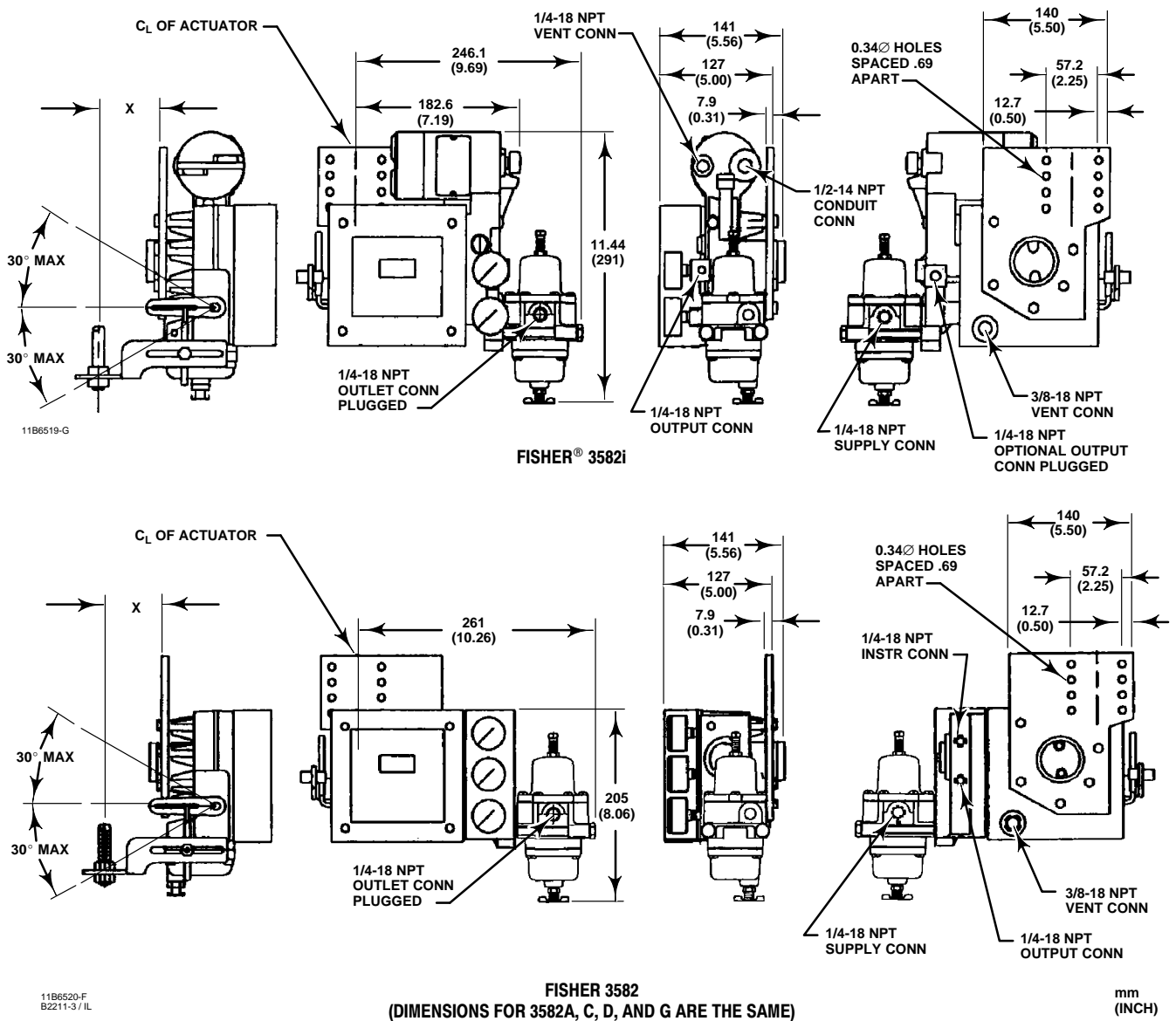

Figure 11. Valve Positioner Dimensions and Connections (see table 4 for the X dimension)

# Product Bulletin

62.1:3582  
April 2009

# 3582 Series

Table 5. Fisher® 582i Electro-Pneumatic Converter<sup>(1)</sup> Hazardous Area Classifications—CSA (Canada)

CERTIFICATION BODY	CERTIFICATION OBTAINED	ENTITY RATING	TEMPERATURE CODE	ENCLOSURE RATING
CSA	(Intrinsic Safety) Zone Ex ia IIC T4/T5/T6 per drawing GE28591 Class/Division Class I, II Division 1 GP A,B,C,D,E,F,G T4/T5/T6 per drawing GE28591	$V_{max} = 30 \text{ VDC}$ $I_{max} = 150 \text{ mA}$ $P_i = 1.25 \text{ W}$ $C_i = 0 \text{ nF}$ $L_i = 0 \text{ mH}$	T4 ( $T_{amb} \leq 71^\circ\text{C}$ ) T5 ( $T_{amb} \leq 62^\circ\text{C}$ ) T6 ( $T_{amb} \leq 47^\circ\text{C}$ )	CSA Type 3 Encl.
	(Explosion Proof) Zone Ex d IIC T6 Class/Division Class I, Division I, GP A,B,C,D T6	---	T6 ( $T_{amb} \leq 71^\circ\text{C}$ )	CSA Type 3 Encl.
	(Type n) Zone Ex nA IIC T6	---	T6 ( $T_{amb} \leq 71^\circ\text{C}$ )	CSA Type 3 Encl.
	Class I, Division 2, GP A,B,C,D T6 Class II, Division 1 GP E,F,G T6 Class II Division 2 GP F,G T6	---	T6 ( $T_{amb} \leq 71^\circ\text{C}$ )	CSA Type 3 Encl.

1. These hazardous area classifications also apply to 3582i positioners.

Table 6. Fisher® 582i Electro-Pneumatic Converter<sup>(1)</sup> Hazardous Area Classifications—FM (United States)

CERTIFICATION BODY	CERTIFICATION OBTAINED	ENTITY RATING	TEMPERATURE CODE	ENCLOSURE RATING
FM	(Intrinsic Safety) Zone Class I Zone 0 AEx ia IIC T4/T5/T6 per drawing GE28590 Class/Division Class I, II, III Division 1 GP A,B,C,D,E, F,G T4/T5/T6 per drawing GE28590	$V_{max} = 30 \text{ VDC}$ $I_{max} = 150 \text{ mA}$ $P_i = 1.25 \text{ W}$ $C_i = 0 \text{ nF}$ $L_i = 0 \text{ mH}$	T4 ( $T_{amb} \leq 71^\circ\text{C}$ ) T5 ( $T_{amb} \leq 62^\circ\text{C}$ ) T6 ( $T_{amb} \leq 47^\circ\text{C}$ )	NEMA 3, IP54
	(Explosion Proof) Zone Class I Zone 1 AEx d IIC T6 Class/Division Class I, Division I, GP A,B,C,D T6	---	T6 ( $T_{amb} \leq 71^\circ\text{C}$ )	NEMA 3, IP54
	(Type n) Zone Class I Zone 2 AEx nA IIC T6	---	T6 ( $T_{amb} \leq 71^\circ\text{C}$ )	NEMA 3, IP54
	Class I Division 2, GP A,B,C,D T6 Class II Division 1, GP E,F,G T6 Class II Division 2, GP F,G T6	---	T6 ( $T_{amb} \leq 71^\circ\text{C}$ )	NEMA 3, IP54

1. These hazardous area classifications also apply to 3582i positioners.

Table 7. Fisher® 582i Electro-Pneumatic Converter<sup>(1)</sup> Hazardous Area Classifications—ATEX

CERTIFICATE	CERTIFICATION OBTAINED	ENTITY RATING	TEMPERATURE CODE	ENCLOSURE RATING
ATEX	Ⓔ II 1 G Gas Ex ia IIC T4/T5/T6—Intrinsic Safety	$U_i = 30 \text{ VDC}$ $I_i = 150 \text{ mA}$ $P_i = 1.25 \text{ W}$ $C_i = 0 \text{ nF}$ $L_i = 0 \text{ mH}$	T4 ( $T_{amb} \leq 71^\circ\text{C}$ ) T5 ( $T_{amb} \leq 62^\circ\text{C}$ ) T6 ( $T_{amb} \leq 47^\circ\text{C}$ )	IP54
	Ⓔ II 2 G Gas Ex d IIC T6 —Flameproof	---	T6 ( $T_{amb} \leq 71^\circ\text{C}$ )	IP54
	Ⓔ II 3 G Gas Ex nA IIC T6 —Type n	---	T6 ( $T_{amb} \leq 71^\circ\text{C}$ )	IP54

1. These hazardous area classifications also apply to 3582i positioners.

Table 8. Fisher® 582i Electro-Pneumatic Converter<sup>(1)</sup> Hazardous Area Classifications—IECEX

CERTIFICATE	CERTIFICATION OBTAINED	ENTITY RATING	TEMPERATURE CODE	ENCLOSURE RATING
IECEX	Gas Ex ia IIC T4/T5/T6—Intrinsic Safety	$U_i = 30\text{ V}$ $I_i = 150\text{ mA}$ $P_i = 1.25\text{ W}$ $C_i = 0\text{ nF}$ $L_i = 0\text{ mH}$	T4 ( $T_{amb} \leq 71^\circ\text{C}$ ) T5 ( $T_{amb} \leq 62^\circ\text{C}$ ) T6 ( $T_{amb} \leq 47^\circ\text{C}$ )	IP54
	Gas Ex d IIC T5/T6 —Flameproof	---	T6 ( $T_{amb} \leq 71^\circ\text{C}$ )	IP54
	Gas Ex nA II T6 —Type n	---	T6 ( $T_{amb} \leq 71^\circ\text{C}$ )	IP54

1. These hazardous area classifications also apply to 3582i positioners.

Table 9. Fisher® 582i Electro-Pneumatic Converter<sup>(1)</sup> Hazardous Area Classifications—SAA (Australia)

CERTIFICATE	CERTIFICATION OBTAINED	TEMPERATURE CODE	ENCLOSURE RATING
SAA	Ex ia IIC T4—Intrinsic Safety	T4 ( $T_{amb} \leq 71^\circ\text{C}$ )	IP54
	Ex n IIC T4—Type n	T4 ( $T_{amb} \leq 71^\circ\text{C}$ )	IP54
	Ex d IIC T6—Flameproof	T6 ( $T_{amb} \leq 40^\circ\text{C}$ )	IP54

1. These hazardous area classifications also apply to 3582i positioners.

Table 10. Fisher® 582i Electro-Pneumatic Converter<sup>(1)</sup> Hazardous Area Classifications—NEPSI

CERTIFICATE	CERTIFICATION OBTAINED	TEMPERATURE CODE	ENCLOSURE RATING
NEPSI	Gas Ex ia IIC T4—Intrinsic Safety Dust DIP A21 T4	T4 ( $T_{amb} \leq 71^\circ\text{C}$ )	---
	Gas Ex d IIC T4—Flameproof Dust DIP A21 T4	T4 ( $T_{amb} \leq 71^\circ\text{C}$ )	---

1. These hazardous area classifications also apply to 3582i positioners.

Table 11. Fisher® 582i Electro-Pneumatic Converter<sup>(1)</sup> Hazardous Area Classifications—INMETRO

CERTIFICATE	CERTIFICATION OBTAINED	ENTITY RATING	TEMPERATURE CODE	ENCLOSURE RATING
INMETRO	BR-Ex ia IIC T6/T5/T4—Intrinsic Safety	$U_i = 60\text{ V}$ $I_i = 150\text{ mA}$ $U_i = 60\text{ V}$ $I_i = 150\text{ mA}$ $U_i = 60\text{ V}$ $I_i = 120\text{ mA}$	T4 (-20°C to 80°C) T5 (-20°C to 50°C) T6 (-20°C to 50°C)	---
	BR Ex d IIC T6— Flameproof		T6 (-20°C to 50°C)	---

1. These hazardous area classifications also apply to 3582i positioners.

Fisher and FlowScanner are marks owned by one of the companies in the Emerson Process Management business division of Emerson Electric Co. Emerson Process Management, Emerson, and the Emerson logo are trademarks and service marks of Emerson Electric Co. All other marks are the property of their respective owners.

The contents of this publication are presented for informational purposes only, and while every effort has been made to ensure their accuracy, they are not to be construed as warranties or guarantees, express or implied, regarding the products or services described herein or their use or applicability. All sales are governed by our terms and conditions, which are available upon request. We reserve the right to modify or improve the designs or specifications of such products at any time without notice. Neither Emerson, Emerson Process Management, nor any of their affiliated entities assumes responsibility for the selection, use or maintenance of any product. Responsibility for proper selection, use, and maintenance of any product remains solely with the purchaser and end-user.

### Emerson Process Management

Marshalltown, Iowa 50158 USA  
Sorocaba, 18087 Brazil  
Chatham, Kent ME4 4QZ UK  
Dubai, United Arab Emirates  
Singapore 128461 Singapore

www.Fisher.com

