

Type 3311 Current-to-Pressure Transducers

Contents

- 1. Introduction
 - Scope of Manual 1-2
 - Description 1-2
 - Specifications 1-3
 - Educational Services 1-3
- 2. Installation
 - Special Instructions for Safe-Use and Installation in Hazardous Locations 2-2
 - CSA 2-2
 - FM 2-2
 - ATEX Intrinsic Safety 2-3
 - ATEX Type n 2-3
 - IECEX Intrinsic Safety, Type n, Dust 2-3
 - ATEX Flameproof
 - IECEX Flameproof 2-3
 - GOST Intrinsic Safety, Flameproof 2-4
 - Mounting 2-5
 - Pressure Connections 2-5
 - Supply Pressure 2-5
 - Output Pressure 2-7
 - Electrical Connections 2-8
 - Venting Ports 2-8
 - Stroke Port 2-12
 - Exhaust Port 2-12
 - Signal Interruption 2-12
- 3. Calibration
 - Standard Performance:
 - Full Range Input, Direct Action 3-2
 - Multirange Performance:
 - Full Range Input, Direct Action 3-3
 - Standard Performance:
 - Split Range Input, Direct Action 3-3
 - 4 to 12 mA Input Signal 3-3
 - 12 to 20 mA Input Signal 3-4
 - Standard Performance:
 - Full Range Input, Reverse Action 3-4
 - Multirange Performance:
 - Full Range Input, Reverse Action 3-4
 - Standard Performance:
 - Split Range Input, Reverse Action 3-5
 - 4 to 12 mA Input Signal 3-5
 - 12 to 20 mA Input Signal 3-5
 - 10 to 50 mA Input Signal 3-6
 - Transporting the Module Final Assembly 3-6



Figure 1-1. Type 3311 Current-to-Pressure Transducer

- 4. Principle of Operation
 - Electronic Circuit 4-1
 - Magnetic Actuator 4-1
 - Pilot Stage 4-1
 - Booster Stage 4-2
- 5. Troubleshooting
 - Diagnostic Features 5-1
 - Stroke Port 5-1
 - Remote Pressure Reading (RPR) 5-1
 - Using the HART® Communicator to Read the RPR Signal 5-1
 - Using a Frequency Counter to Read the RPR Signal 5-2
 - In-service Troubleshooting 5-3
 - Troubleshooting in the Shop 5-5
- 6. Maintenance
 - Module Final Assembly 6-1
 - Removing the Module Final Assembly 6-3
 - Replacing the Module Final Assembly 6-4
 - Electronic Circuit Board 6-5
 - Remote Pressure Reading (RPR) Jumper 6-5

(continued on next page)



3311 Transducers

Contents (continued)

Range Jumper	6-6
Action	6-6
Removing the Electronic Circuit Board	6-6
Replacing the Electronic Circuit Board	6-6
Pilot/Actuator Assembly	6-7
Action	6-7
Removing the Pilot/Actuator Assembly ...	6-7
Replacing the Pilot/Actuator Assembly	6-7
Module Subassembly	6-8
Terminal Compartment	6-9
Exhaust and Stroke Port Screens	6-9
7. Parts List	7-1
8. Loop Schematics/Nameplates	8-1

Section 1 Introduction

Scope of Manual

This instruction manual provides installation, operating, calibration, maintenance, and parts ordering information for Type 3311 current-to-pressure transducers. Refer to separate manuals for instructions covering equipment used with the transducers.

Do not install, operate or maintain an 3311 current-to-pressure transducer without first • being fully trained and qualified in valve, actuator and accessory installation, operation and maintenance, and • carefully reading and understanding the contents of this manual. If you have any questions about these instructions, contact your Emerson Process Management™ sales office before proceeding.

Description

The Type 3311 current-to-pressure transducer, shown in figure 1-1, accepts an electrical input signal and produces a proportional pneumatic output. Typically, 4 to 20 mA is converted to 0.2 to 1.0 bar (3 to 15 psi). Models are available in direct or reverse action and field-selectable full or split range

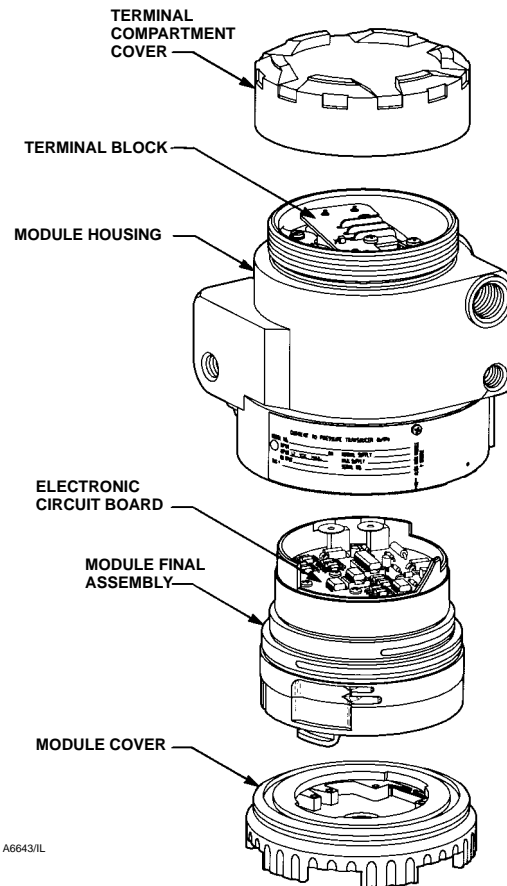
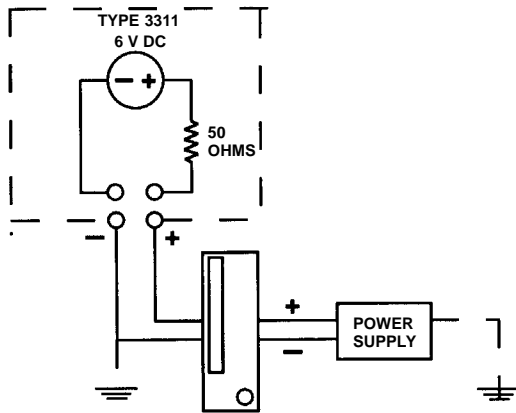

Figure 1-2. Transducer Modular Construction

inputs. Refer to the Calibration section for more information on input/output combinations.

The most common application of the transducer is to receive an electrical signal from a controller and produce a pneumatic output for operating a control valve actuator or positioner. Type 3311 may also be used to transduce a signal for a pneumatic receiving instrument.

The Type 3311 is an electronic I/P transducer. It has a single electronic circuit board, as shown in figure 1-2. The circuit contains a solid-state pressure sensor that monitors output pressure and is part of an electronic feedback network. The self-correcting ability provided by the sensor/circuit combination allows the transducer to produce a very stable and responsive output signal.



NOTE:
TYPE 3311 IS NOT A CONSTANT RESISTOR IN SERIES WITH AN INDUCTOR. IT IS BETTER MODELED IN THE LOOP AS A 50 OHM RESISTOR IN SERIES WITH A 6-VOLT DC VOLTAGE DROP WITH NEGLIGIBLE INDUCTANCE.

A6325 / IL

Figure 1-3. Equivalent Circuit

All active mechanical and electrical components of Type 3311 is incorporated into a single, field-replaceable module called the module final assembly, shown in figure 1-2. The module final assembly contains the electronic circuit board, pilot/actuator assembly, and booster stage. The module final assembly is easily removed by unscrewing the module cover. Its design minimizes parts and reduces the time required for repair and troubleshooting.

The terminal compartment and module compartment are separated by a sealed compartment wall. This multi-compartment housing also protects the electronics from contaminants and moisture in the supply air.

Specifications

WARNING

This product is intended for a specific range of pressures, temperatures, and other application specifications. Applying different pressure, temperature and other service conditions could result in a malfunction of the product, property damage or personal injury.

Specifications for the Type 3311 transducer are listed in table 1-1.

Educational Services

For information on available courses for the Type 3311 current-to-pressure transducer, as well as a variety of other products, contact:

Emerson Process Management
Educational Services, Registration
P.O. Box 190; 301 S. 1st Ave.
Marshalltown, IA 50158-2823
Phone: 800-338-8158 or
Phone: 641-754-3771
FAX: 641-754-3431
e-mail: education@emersonprocess.com



3311 Transducers

Table 1-1. Specifications

<p>Input Signal</p> <p>Standard Performance: 4 to 20 mA DC, 4 to 12 mA DC, or 12 to 20 mA DC. Field adjustable split ranging.</p> <p>10 to 50 mA DC. Consult factory for split range input. Direct action only.</p> <p>Multirange Performance: 4 to 20 mA DC. Consult factory for split range input.</p> <p>10 to 50 mA DC. Consult factory for split range input. Direct action only.</p> <p>Equivalent Circuit</p> <p>See figure 1-3</p> <p>Output Signal⁽¹⁾</p> <p>Standard Performance: <i>(Consult factory for split range output)</i> Direct Action (Minimum span of 6 psi) Typical outputs: 0.2 to 1.0 bar (3 to 15 psi). Rangeability between 0.1 and 1.2 bar (1 and 18 psi)</p> <p>Reverse Action (Minimum span of 11 psi) Typical outputs: 1.0 to 0.2 bar (15 to 3 psi) Rangeability between 1.2 and 0.1 bar (18 and 1 psi)</p> <p>Multirange Performance: Direct Action (Minimum span of 6 psi) Typical outputs: 0.2 to 1.9 bar (3 to 27 psi), 0.4 to 2 bar (6 to 30 psi), and 0.3 to 1.7 bar (5 to 25 psi) Rangeability between 0.03 and 2.3 bar (0.5 and 33 psi)</p> <p>Reverse Action (Minimum span of 11 psi) Typical outputs: 1.9 to 0.2 bar (27 to 3 psi), 2 to 0.4 bar (30 to 6 psi), and 1.7 to 0.3 bar (25 to 5 psi) Rangeability between 2.3 and 0.03 bar (33 and 0.5 psi)</p> <p>Supply Pressure⁽²⁾</p> <p>Standard Performance: 1.2 to 1.6 bar (18 to 24 psi)</p> <p>Multirange Performance: 0.2 bar (3 psi)⁽³⁾ greater than the maximum calibrated output pressure</p> <p>Maximum: 2.4 bar (35 psi)</p>	<p>Supply Pressure Medium</p> <p>Air or natural gas⁽⁴⁾</p> <p><i>Air Quality:</i> Supply pressure must be clean, dry air that meets the requirements of ISA Standard 7.0.01. A maximum 40 micrometer particle size in the air system is acceptable. Further filtration down to 5 micrometer particle size is recommended. Lubricant content is not to exceed 1 ppm weight (w/w) or volume (v/v) basis. Condensation in the air supply should be minimized</p> <p><i>Natural Gas:</i> Natural gas must be clean, dry, oil-free, and noncorrosive. H₂S content should not exceed 20 ppm.</p> <p>Output Air Capacity⁽⁵⁾</p> <p>Standard: 6.4 normal m³/hr (240 scfh) at 1.4 bar (20 psi) supply pressure</p> <p>Multirange: 9.7 normal m³/hr (360 scfh) at 2.5 bar (35 psig) supply pressure</p> <p>Steady-State Air Consumption⁽⁵⁾</p> <p>0.3 normal m³/hr (12 scfh) at 1.4 bar (20 psi) supply pressure</p> <p>Temperature Limits⁽²⁾</p> <p>Operating: -40 to 85°C (-40 to 185°F)</p> <p>Storage : -40 to 93°C (-40 to 200°F)</p> <p>Humidity Limits</p> <p>0 to 100% condensing relative humidity</p> <p>Performance⁽⁶⁾</p> <p>Note: <i>The performance of all Type 3311 I/Ps is verified using computer automated manufacturing systems to ensure that every unit shipped meets its performance specifications.</i></p> <p>Linearity, Hysteresis, and Repeatability: ±0.3% of span.</p> <p>Temperature Effect (total effect including zero and span): ±0.07%/°C (0.045%/°F) of span</p> <p>Vibration Effect: ±0.3% of span per g during the following conditions: 5 to 15 Hz at 4 mm constant displacement 15 to 150 Hz at 2 g. 150 to 2000 Hz at 1 g. per SAMA Standard PMC 31.1, Sec. 5.3, Condition 3, Steady State</p>
---	--

-Continued-

Table 1-1. Specifications (continued)

<p>Performance (continued)⁽⁶⁾</p> <p>Shock Effect: ±0.5% of span, when tested per SAMA Standard PMC 31.1, Sec. 5.4.</p> <p>Supply Pressure Effect: Negligible</p> <p>Electromagnetic Interference (EMI): Tested per IEC 61326-1 (Edition 1.1). Meets emission levels for Class A equipment (industrial locations) and Class B equipment (domestic locations). Meets immunity requirements for industrial locations (Table A.1 in the IEC specification document). Immunity performance is shown in table 1-2.</p> <p>Leak Sensitivity⁽⁵⁾: Less than 1.0% of span for up to 4.8 normal m³/hr (180 scfh) downstream leakage.</p> <p>Overpressure Effect: Less than 0.25% of span for misapplication of up to 7.0 bar (100 psi) supply pressure for less than 5 minutes to the input port.</p> <p>Reverse Polarity Protection:</p> <p>No damage occurs from reversal of normal supply current (4 to 20 mA) or from misapplication of up to 100 mA.</p> <p>Connections</p> <p>Supply Air, Output Signal, and Output Gauge: 1/4-18 NPT internal connection</p> <p>Electrical: 1/2-14 NPT internal conduit connection</p> <p>Adjustments</p> <p>Zero and Span: screwdriver adjustments located in terminal compartment.</p> <p>Remote Pressure Reading (RPR) Jumper selectable, ON or OFF, if unit includes option</p> <p>Frequency Range: 5,000 to 8,000 Hz</p> <p>Amplitude: 0.4 to 1.0 V_{p-p}</p>	<p>Required Operating Voltage with Remote pressure Reading Off</p> <p>Min. 6.0 V (at 4 mA) Max. 7.2 V (at 20 mA)</p> <p>Required Operating Voltage with Remote Pressure Reading On</p> <p>Min 6.4 V (at 4 mA) Max. 8.2 V (at 20 mA)</p> <p>Electrical Classification</p> <p>Hazardous area:</p> <p> Intrinsic Safety, Flameproof, and Div. 2</p> <p> Intrinsic Safety, Flameproof, and Dust-Ignition Proof</p> <p>ATEX Intrinsic Safety, Flameproof, and Type n</p> <p>IECEx Intrinsic Safety, Flameproof, and Type n</p> <p>GOST Intrinsic Safety, Flameproof, and Type n</p> <p>Refer to Special Instructions for Safe-Use and Installation in Hazardous Locations in Section 2, tables 2-1, 2-2, 2-3, 2-4, and 2-5 and the schematic and nameplate figures in Section 8 for specific approval information.</p> <p>Approved for use with natural gas⁽⁴⁾</p> <p>Electrical Housing: NEMA 4X, CSA Enclosure Type 4X, IP66, Tropicalization (Fungus test per MIL-STD-810)</p> <p>Construction Materials</p> <p>Housing: Low-copper aluminum with polyurethane paint, or 316 stainless steel</p> <p>O-Rings: Nitrile, except silicone for sensor O-rings.</p> <p>Options</p> <p>Type 67CFR filter regulator, supply and output gauges or tire valve remote pressure reading, module cover with multiple stroke ports, stainless steel housing, or stainless steel mounting bracket.</p> <p>Weight</p> <p>Aluminum: 2.9 kg (6.5 lb) excluding options</p> <p>Stainless Steel: 6.7 kg (14.8 lb) excluding options</p>
---	--

-Continued-

3311 Transducers

Table 1-1. Specifications (continued)

<p>Declaration of SEP</p> <p>Fisher Controls International LLC declares this product to be in compliance with Article 3 paragraph 3 of the Pressure Equipment Directive (PED) 97 / 23 / EC. It was designed and manufactured in accordance with Sound</p>	<p>Engineering Practice (SEP) and cannot bear the CE marking related to PED compliance.</p> <p>However, the product <i>may</i> bear the CE marking to indicate compliance with <i>other</i> applicable European Community Directives.</p>
--	---

NOTE: Specialized instrument terms are defined in ANSI/ISA Standard 51.1 – Process Instrument Terminology.

1. Metric calibration also available.
2. The pressure/temperature limits in this document, and any applicable standard or code limitation should not be exceeded.
3. 0.14 bar (2 psi) for a 2.3 bar (33 psi) output.
4. Natural gas should contain no more than 20 ppm of H₂S. Natural gas as the supply medium is only approved for CSA and FM approvals, as specified in tables 2-1 and 2-2. Type 3311 is not recommended for use with aromatic gas.
5. Normal m³/hr—Normal cubic meters per hour (0°C and 1.01325 bar, absolute). Scfh—Standard cubic feet per hour (60°F and 14.7 psia).
6. Reference Conditions: 4.0 to 20 mA DC input, 0.2 to 1.0 bar (3 to 15 psi) output, and 1.4 bar (20 psi) supply pressure.

Table 1-2. EMC Immunity Performance Criteria

PORT	PHENOMENON	BASIC STANDARD	TEST LEVEL	PERFORMANCE CRITERIA ⁽¹⁾
Enclosure	Electrostatic discharge (ESD)	IEC 61000-4-2	4 kV contact 8 kV air	A
	Radiated EM field	IEC 61000-4-3	80 to 1000 MHz @ 10V/m with 1 kHz AM at 80%	A
	Rated power frequency magnetic field	IEC 61000-4-8	60 A/m at 50 Hz	A
I/O signal/control	Burst (fast transients)	IEC 61000-4-4	1 kV	A
	Surge	IEC 61000-4-5	1 kV (line to ground only, each)	B
	Conducted RF	IEC 61000-4-6	150 kHz to 8 MHz at 3 Vrms	B
8 MHz to 80 MHz at 3 Vrms			A	

Specification limit = ±1% of span
 1. A = No degradation during testing. B = Temporary degradation during testing, but is self-recovering.

Section 2 Installation

The Type 3311 current-to-pressure transducer has been approved for use with either air or natural gas as the supply medium. If using natural gas as the pneumatic supply medium, natural gas will be used in the pressure connections of the transducer to any connected equipment, and the unit will vent natural gas into the surrounding atmosphere.

WARNING

Not all markings for a given approval agency are approved for use with natural gas as the supply medium. Refer to tables 2-1, 2-2, 2-3, 2-4, and 2-5 for specific approval information. Use of natural gas as the supply medium in unapproved units may result in personal injury or property damage from fire or explosion.

CAUTION

Type 3311 is not recommended for use with aromatic gas. The silicone diaphragm and nitrile o-rings and gaskets used in the 3311 transducer are subject to degradation when exposed to aromatic gas.

WARNING

To avoid personal injury or property damage from the sudden release of pressure, air, or natural gas:

- Always wear protective clothing, gloves, and eyewear when performing any installation operations.
- Disconnect any operating lines providing air pressure, electric power, or a control signal to the actuator. Be sure the actuator cannot suddenly open or close the valve.
- Use bypass valves or completely shut off the process to isolate the valve from process pressure. Relieve

process pressure on both sides of the valve.

- Use lock-out procedures to be sure that the above measures stay in effect while you work on the equipment.
- Check with your process or safety engineer for any additional measures that must be taken to protect against process media.

WARNING

This unit vents the supply medium into the surrounding atmosphere. Personal injury or property damage may result from fire or explosion if natural gas is used as the supply medium and preventative measures are not taken, such as adequate ventilation and the removal of any ignition sources.

This section presents information on installing the Type 3311 current-to-pressure transducer. Figures 2-1, 2-2, 2-3, and 2-5 can be used as references for instructions contained in this section.

When a control valve is ordered with a Type 3311 transducer specified to be mounted on the actuator, the factory-mounted transducer is connected to the actuator with the necessary tubing and calibrated to the specifications on the order.

If the transducer is purchased separately for mounting on a control valve already in service, all the necessary mounting parts are furnished, if ordered. This includes the appropriate bracket for attaching the unit to an actuator boss (with tapped holes) or for attaching it to the diaphragm casing.

If preferred, mounting parts can be supplied for mounting the transducer on a 51 mm (2-inch) diameter pipestand, a flat surface, or a bulkhead.

Transducers also can be ordered separately for mounting on a control valve assembly already in service. The transducer may be ordered with or without mounting parts. Mounting parts include the appropriate bracket and bolts for attaching the unit to an actuator boss (with tapped holes) or for attaching it to the diaphragm casing.

Table 2-1. Hazardous Area Classifications for Canada—CSA

CERTIFICATION BODY	CERTIFICATION OBTAINED	ENTITY RATING	TEMPERATURE CODE	ENCLOSURE RATING
CSA	(Intrinsic Safety) Class/Division Intrinsic Safety Class I Division 1 Groups A,B,C,D per DWG 13B8779 Approved for use with natural gas	---	T4 ($T_{amb} \leq 80^{\circ}C$)	TYPE 4X
	(Explosion Proof) Class/Division Class I Division 1 Groups C,D Approved for use with natural gas	---	T4 ($T_{amb} \leq 80^{\circ}C$)	TYPE 4X
	Class I, Division 2, Groups A,B,C,D Class II, III Division 1, Groups E,F,G Approved for use with natural gas	---		TYPE 4X

Table 2-2. Hazardous Area Classification for United States—FM

CERTIFICATION BODY	CERTIFICATION OBTAINED	ENTITY RATING	TEMPERATURE CODE	ENCLOSURE RATING
FM	(Intrinsic Safety) Class/Division Class I, II, III Division 1 Groups A,B,C,D,E,F,G per drawing 13B8780 Approved for use with natural gas	$V_{max} = 40$ VDC $I_{max} = 185$ mA $C_i = 0.016$ μ F $L_i = 20$ μ H	T5 ($T_{amb} \leq 60^{\circ}C$)	NEMA 4X
	(Explosion Proof) Class/Division Class I, Division 1, Groups B,C,D Approved for use with natural gas – Groups C,D only	---	T5 ($T_{amb} \leq 60^{\circ}C$)	NEMA 4X
	Class I, Division 2, Groups A,B,C,D Class II, III Division 1, Groups E,F,G Not approved for use with natural gas	---	T5 ($T_{amb} \leq 60^{\circ}C$)	NEMA 4X

Special Instructions for Safe Use and Installation in Hazardous Locations

Certain nameplates may carry more than one approval, and each approval may have unique installation requirements and/or conditions of safe use. Special instructions are listed by agency/approval.

After reading and understanding these special conditions of use, proceed with standard installation procedures.



Failure to follow these conditions of safe-use could result in personal injury or property damage from fire or explosion, and area re-classification.

CSA

Special Conditions of Use

No special conditions of use.

Refer to table 2-1 for approval information, figure 8-1 for the CSA loop schematic, and figure 8-2 for the CSA and FM approvals nameplate.

FM

Special Conditions of Use

1. When product is used with natural gas as the pneumatic medium, the maximum working pressure of the natural gas supply is limited to 35 psi.
2. When product is used with natural gas as the pneumatic medium the product shall not be permitted in a Class I, Division 1, Group B location.
3. When product is used with natural gas as the pneumatic medium the product shall not be permitted in a Class 1, Division 2, Group A, B, C, D location.

Refer to table 2-2 for additional approval information, figure 8-3 for the FM loop schematic, and figure 8-2 for the CSA and FM approvals nameplate.

Table 2-3. Hazardous Area Classifications—ATEX⁽¹⁾

CERTIFICATE	CERTIFICATION OBTAINED	ENTITY RATING	TEMPERATURE CODE	ENCLOSURE RATING
ATEX	Ⓢ II 1 G & D Gas EEx ia IIC T4, T5 —Intrinsic Safety Dust T 90°C (Tamb = 80°C)	U _i = 40 VDC I _i = 200 mA P _i = 1.0 W C _i = 8 nF L _i = 20 μH	T4 (T _{amb} ≤ 80°C) T5 (T _{amb} ≤ 40°C)	IP66
	Ⓢ II 3 G & D Gas EEx nL IIC T5, T6 —Type n Dust T 95°C (Tamb = 85°C)	---	T5 (T _{amb} ≤ 85°C) T6 (T _{amb} ≤ 74°C)	IP66
	Ⓢ II 2 G & D Gas EEx d IIB T5/T6 —Flameproof Dust T 90°C (Tamb = 80°C)	---	T5 (T _{amb} ≤ 80°C) T6 (T _{amb} ≤ 65°C)	IP66

1. Not approved for use with natural gas as the supply medium.

ATEX Intrinsic Safety

Special Conditions for Safe Use

This equipment is intrinsically safe and can be used in potentially explosive atmospheres.

The apparatus must be only connected to a certified associated intrinsically safe equipment and this combination must be compatible as regards intrinsic safety rules.

The electrical parameters of certified equipment which can be connected to the sensor must not exceed one of these following values:

$$U_0 \leq 40 \text{ V}$$

$$I_0 \leq 200 \text{ mA}$$

$$P_0 \leq 1.0 \text{ W}$$

Ambient temperature:

$$-40^\circ\text{C to } +80^\circ\text{C}$$

Refer to table 2-3 for additional information, and figure 8-4 for ATEX nameplates.

ATEX Type n

Special Conditions for Safe Use

No special conditions for safe use.

Refer to table 2-3 for approval information, and figure 8-4 for ATEX nameplates.

IECEx Intrinsic Safety, Dust, Type n

Special Conditions for Safe Use

These approvals come with a combined nameplate which carries multiple approvals (intrinsic safety, dust, and type n) as shown in figure 8-5. During installation, only one type of protection method is allowed. The unit shall be marked as to which protection method it was installed as and shall not be changed or utilized in any other manner than was originally marked by the end-user.

Refer to table 2-4 for additional approval information.



End-user must select and mark only one protection method upon installation. Once marked it shall not be changed. Failure to follow these instructions will jeopardize the explosion safety of the transducer, and may result in personal injury or property damage.

ATEX Flameproof IECEx Flameproof

Special Conditions for Safe Use

1. The equipment incorporates flameproof joints which have a maximum gap less than that stated in EN 60079-1. The user shall refer to the manufacturer's installation, operation, and maintenance document for guidance.

3311 Transducers

Table 2-4. Hazardous Area Classifications—IECEX⁽¹⁾

CERTIFICATE	CERTIFICATION OBTAINED	ENTITY RATING	TEMPERATURE CODE	ENCLOSURE RATING
IECEX	Gas Ex ia IIC T4/T5 —Intrinsic Safety Dust DIP A20 T _A 90°C IP66	U _i = 40 VDC I _i = 200 mA P _i = 1.0 W C _i = 8 nF L _i = 20 μH	T4 (T _{amb} ≤ 80°C) T5 (T _{amb} ≤ 40°C)	IP66
	Gas Ex nL IIC T5/T6 —Type n Dust DIP A22 T _A 90°C IP66	---	T5 (T _{amb} ≤ 80°C) T6 (T _{amb} ≤ 75°C)	IP66
	Dust DIP A20 T _A 90°C IP66	---	---	IP66
	Gas Ex d IIB T5/T6 —Flameproof Dust DIP A21 T _A 90°C IP66	---	T5 (T _{amb} ≤ 80°C) T6 (T _{amb} ≤ 65°C)	IP66

1. Not approved for use with natural gas as the supply medium.

Table 2-5. Hazardous Area Classifications—GOST⁽¹⁾

CERTIFICATE	CERTIFICATION OBTAINED	ENTITY RATING	TEMPERATURE CODE	ENCLOSURE RATING
GOST	Gas Ex ia IIC T4/T5 —Intrinsic Safety	U _i = 30 V I _i = 200 mA P _i = 1.2 W C _i = 10 nF L _i = 20 μH	T4 (T _{amb} ≤ 80°C) T5 (T _{amb} ≤ 40°C)	IP66
	Gas Ex d IIB T5/T6 —Flameproof	---	T5 (T _{amb} ≤ 80°C) T6 (T _{amb} ≤ 65°C)	IP66
	Gas Ex nL IIC T5/T6—Type n	---	T5 (T _{amb} ≤ 80°C) T6 (T _{amb} ≤ 74°C)	IP66

1. Not approved for use with natural gas as the supply medium.

- The cable entry device used shall meet the following requirements:
 - Be certified Ex d IIB or Ex d IIC.
 - Afford an ingress protection rating of IP66 or better.
- The user shall ensure that the maximum system pressure does not exceed 35 psi.
- Refer to figures 2-2 and 2-3 for proper bolting engagement length for ATEX and IECEX flameproof units.
- A cable entry hole is provided for the accommodation of a flameproof cable entry device, with or without the interposition of a flameproof thread adaptor.

For IECEX certified versions of Type 3311 transducers—the cable entry device and thread adaptor shall be suitable for the equipment, the cable and the conditions of use and shall be certified as Equipment (not a Component). Refer to table 2-4 for additional approval information and figure 8-5 for IECEX nameplates.

For ATEX certified versions of Type 3311 transducers—the cable entry device and thread adaptor shall be suitable for the equipment, the cable and the conditions of use and shall be certified as Equipment (not a Component) under an EC Type Examination Certificate to Directive 94/9/EC.

Refer to table 2-3 for additional approval information, and figure 8-4 for ATEX nameplates.

GOST Intrinsic Safety, Flameproof

Condition of Use

- Transducer is to be used in accordance with explosion proof mark, requirements of GOST R 51330.13, current "Electrical plant arrangement rules" (PUE, art. 7.3), "Technical maintenance rules for electrical plants" (PTEEP, art. 3.4), other normative documents regulating application of electrical equipment in explosive areas, and manufacturer's instruction manual.
- Applicable explosive areas and condition of the transducer use, categories and groups of explosive air mixtures with gases and vapors are in accordance with GOST R 51330.9, GOST R 51330.11 and requirements of "Electrical plants arrangement rules" (PUE, art.7.3).

3. Devices connected to Exia circuit of the transducer are to have spark-safe electrical circuit as per GOST R 51330.10, and their spark-safe characteristics (e.g. class of spark-safe electrical circuit and subgroup of electrical equipment) are to comply with conditions of the transducer use.
4. The transducer with Exd explosion proof is to be used together with certified cable glands and plugs which provide appropriate method and level of explosion protection of the enclosure.
5. The transducer is certified for use in areas which are hazardous by ignition of combustible dust according to parameters: maximum temperature of transducer surface $T 90^{\circ}\text{C}$ with $t_{amb} = - 40\dots +80^{\circ}\text{C}$, ingress protection – IP 66.
6. Technical documentation set for the transducer is to include copy of this certificate of Conformity.
7. The transducer design modification related to explosion proof method is to be coordinated with licensed test laboratory.

Refer to table 2-5 for approval information.

Mounting

The transducer is designed for mounting on a control valve, 51 mm (2-inch) diameter pipestand, wall, or panel. Figures 2-2, 2-3, 2-4, and 2-5 show recommended mounting configurations. The mounting positions shown allow any moisture buildup in the terminal compartment to drain to the signal wire conduit entrance. Any moisture in the pilot stage area will be expelled through the stroke port without affecting pilot stage operation. In applications with excessive moisture in the supply air, vertical mounting allows the most effective drainage through the stroke port.

CAUTION

Do not mount the transducer with the terminal compartment cover on the bottom as moisture, or any corrosive elements in the plant atmosphere, may accumulate in the terminal compartment or pilot stage, resulting in transducer malfunction.

Mounting is accomplished with an optional universal mounting bracket. Before mounting the transducer, note the following recommendations:

- Ensure that all bolts are fully tightened. The recommended torque is 22 N•m (16 lbf•ft).
- Bolts that connect to the transducer and to a valve actuator should have the lock washer placed directly beneath the bolt head and the flat washer placed between the lock washer and bracket. All other bolts should have the lock washer next to the nut, and the flat washer placed between the lock washer and bracket.
- Do not mount the transducer in a location where foreign material may cover the stroke port or exhaust port. See the descriptions of the stroke port and exhaust port later in this section.

Pressure Connections

As shown in figure 2-1, all pressure connections are 1/4-18 NPT internal connections. Use 9.5 mm (3/8-inch) outside diameter tubing for the supply and output connections.

Supply Pressure



WARNING

Severe personal injury or property damage may occur from process instability if the instrument supply medium is not clean, dry, air or non-corrosive gas. While use and regular maintenance of a filter that removes particles larger than 40 microns in diameter will suffice in most applications, check with an Emerson Process Management field office and industry instrument air quality standards for use with corrosive gas or if you are unsure about the proper amount or method of air filtration or filter maintenance.

The supply medium must be clean, dry air that meets the requirements of ISA Standard 7.0.01. or noncorrosive gas. An output span of 0.2 to 1.0 bar (3 to 15 psi) requires a nominal supply pressure of 1.4 bar (20 psi) and a flow capacity not less than 6.4 normal m³/hr (240 scfh).

3311 Transducers

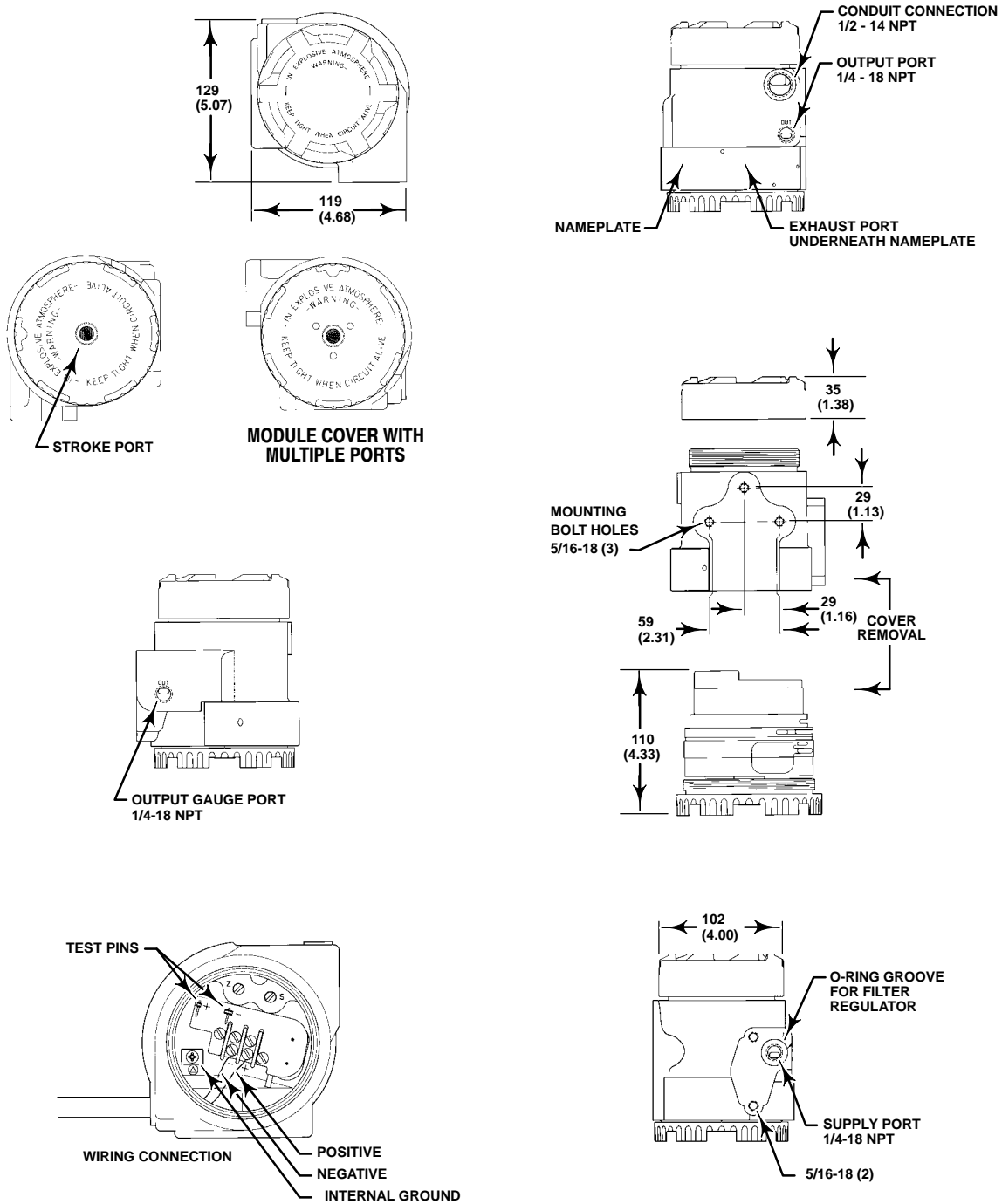

NOTE:

REFER TO FIGURE 2-5 FOR TRANSDUCER DIMENSIONS WITH ATEX / IECEx FLAMEPROOF CERTIFICATIONS

B2473-1/L

mm
(INCHES)

Figure 2-1. Typical Dimensions and Connection Locations (Aluminum Construction Shown)

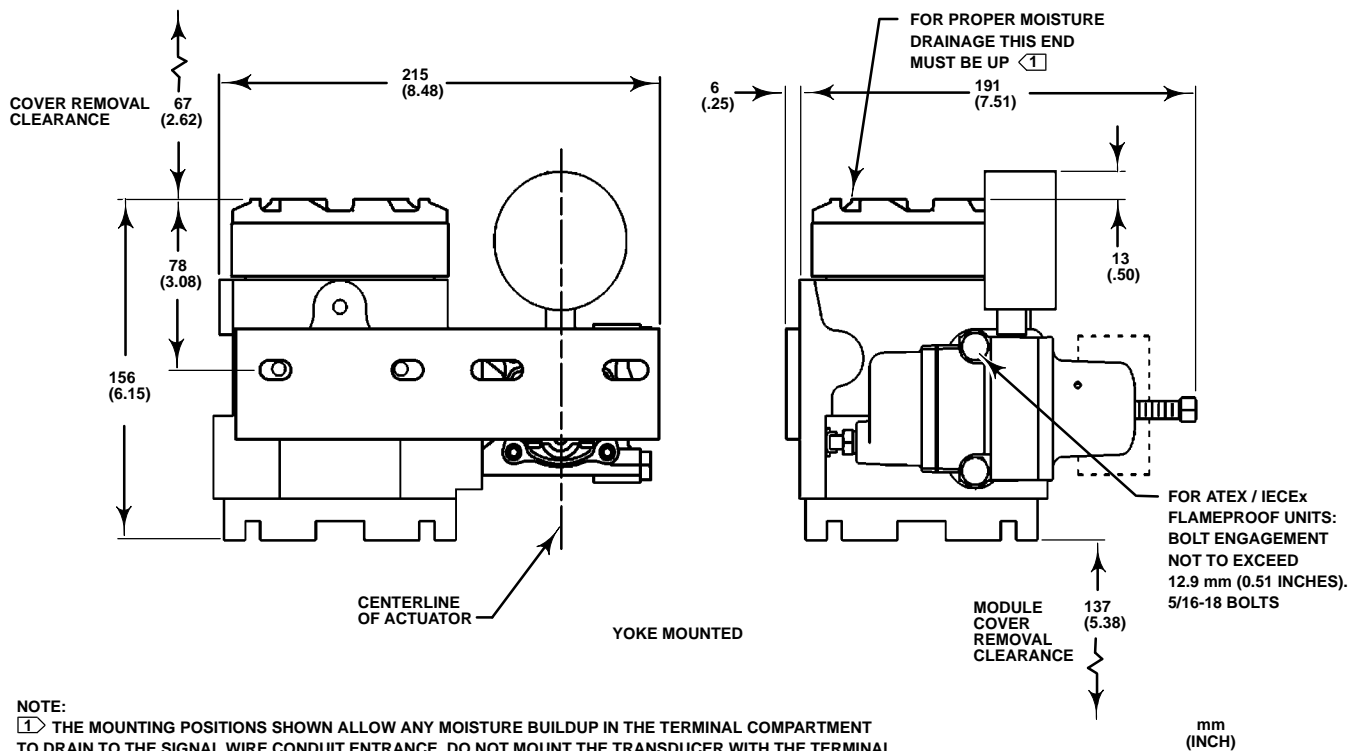

NOTE:
 [1] THE MOUNTING POSITIONS SHOWN ALLOW ANY MOISTURE BUILDUP IN THE TERMINAL COMPARTMENT TO DRAIN TO THE SIGNAL WIRE CONDUIT ENTRANCE. DO NOT MOUNT THE TRANSDUCER WITH THE TERMINAL COMPARTMENT COVER ON THE BOTTOM; MOISTURE MAY ACCUMULATE IN THE TERMINAL COMPARTMENT OR PILOT STAGE, PREVENTING PROPER TRANSDUCER OPERATION. THE VERTICAL MOUNT IS MOST EFFECTIVE FOR MOISTURE DRAINAGE IN WET APPLICATIONS.

14B7361-D
 A6R26-3/IL

Figure 2-2. Typical Dimensions with Type 67CFR Filter/Regulator and Gauges

For multirange performance units with higher output spans, the supply pressure should be at least 0.2 bar (3 psi) greater than the maximum calibrated output pressure.

The air supply line can be connected to the 1/4-18 NPT supply port, or to the supply port of a filter-regulator mounted directly to the transducer. Figures 2-2, 2-3, 2-4, and 2-5 show the installation options.

The mounting boss for the air supply connection contains two 5/16-18 UNC tapped holes that are 2-1/4 inches apart. The tapped holes allow direct connection (integral mount) of a Type 67CFR filter-regulator, if desired. When the filter-regulator is factory mounted, the mounting hardware consists of two 5/16-18 x 3-1/2 inch stainless steel bolts and one O-ring. When the filter-regulator is field mounted, the mounting hardware consists of two 5/16-18 x 3-1/2 inch stainless steel bolts, two spacers (which may or may not be required) and two O-rings (of which only one will fit correctly into the

housing O-ring groove and the other may be discarded). This is due to the fact that the current housing has been slightly modified from its original design, hence, the additional hardware (if needed) when field mounting the Type 67CFR filter-regulator.

Output Pressure

Connect the output signal line to the transducer at the output port. The output port is 1/4-18 NPT, as shown in figure 2-1. The output gauge port can be used as an alternate signal port. If the gauge port is used as a signal port, a threaded plug must be installed in the output port.

The output gauge port allows connection of an output gauge to provide local output signal indication. The output gauge port is 1/4-18 NPT. If an output gauge is not specified, a threaded plug is shipped with the transducer. The plug must be installed in the output gauge port when the port is not used.

3311 Transducers

Electrical Connections

 **WARNING**

Personal injury or property damage could result from fire or explosion. In explosive atmospheres, remove power and shut off the air supply to the I/P unit before attempting to remove the terminal compartment cover or module cover. Failure to do so could result in an electrical spark or explosion.

Personal injury or property damage could result from an uncontrolled process. Unscrewing the module cover removes power from the electronics and the output signal will be 0.0 psi. Perform the steps in the **WARNING** at the beginning of this section before removing the module cover to ensure the process is properly controlled.

CAUTION

Excessive current can damage the transducer. Do not connect an input current of more than 100 mA to the transducer.

Note

For North American explosion-proof applications, 3311 transducers have been designed so that a conduit seal is not required. For all other applications install the product per local, regional, or national code, rules, and regulations.

 **WARNING**

Select wiring and/or cable glands that are rated for the environment of use (such as hazardous location, ingress protection, and temperature). Failure to use properly rated wiring and/or cable glands can result in personal

injury or property damage from fire or explosion.

Signal wiring is brought to the terminal compartment through a 1/2-14 NPT housing conduit connection, shown in figure 2-1. Where condensate is common, use a conduit drip leg to help reduce liquid buildup in the terminal compartment and avoid shorting of the input signal. Electrical connections are made at the terminal block. Internal and external grounding lugs are provided to facilitate a separate ground when required. The internal ground is shown in figure 2-1, and the external grounding lug is shown in figure 2-5.

Connect the positive signal lead to the positive terminal, marked +. Connect the negative signal lead to the negative terminal, marked –.

Note

Units with the Remote Pressure Reading (RPR) option may cause interference with the analog output signal from some instrumentation systems. This problem may be solved by placing a 0.2 microfarad capacitor or a HART filter across the output terminals.

Venting Ports

 **WARNING**

Regardless of the supply medium used, this unit will vent to the atmosphere through the stroke port in the module cover and the exhaust port, located under the nameplate. Do not remote vent this unit.

Personal injury or property damage may result from fire or explosion if natural gas is used as the supply medium and preventive measures are not taken. Preventive measures may include: Re-evaluating the hazardous area classification, ensuring adequate ventilation, and the removal of any ignition sources.

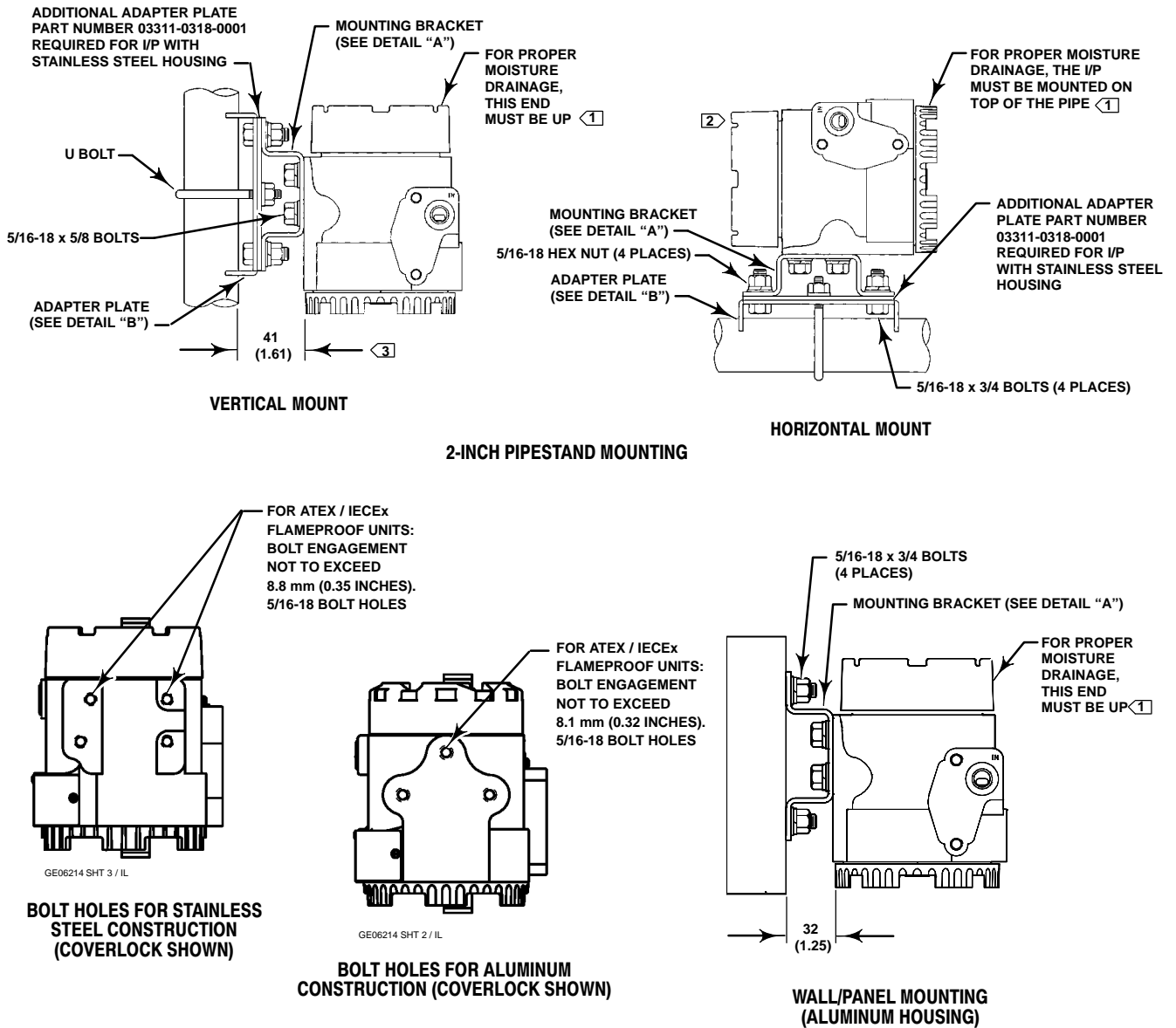

NOTES:

- 1 THE MOUNTING POSITIONS SHOWN ALLOW ANY MOISTURE BUILDUP IN THE TERMINAL COMPARTMENT TO DRAIN TO THE SIGNAL WIRE CONDUIT ENTRANCE. DO NOT MOUNT THE TRANSDUCER WITH THE TERMINAL COMPARTMENT COVER ON THE BOTTOM; MOISTURE MAY ACCUMULATE IN THE TERMINAL COMPARTMENT OR PILOT STAGE, PREVENTING PROPER TRANSDUCER OPERATION. THE VERTICAL MOUNT IS MOST EFFECTIVE FOR MOISTURE DRAINAGE IN WET APPLICATIONS.
- 2 IF MOUNTED ON HORIZONTAL PIPE, THE I/P MUST BE ON TOP OF THE PIPE FOR PROPER MOISTURE DRAINAGE.
- 3 THIS DIMENSION IS 44 (1.74) FOR STAINLESS STEEL HOUSING.

14B7332
19B9494-B
E0786 / IL

mm
(INCH)

Figure 2-3. Typical Transducer Mounting with Universal Mounting Bracket

3311 Transducers

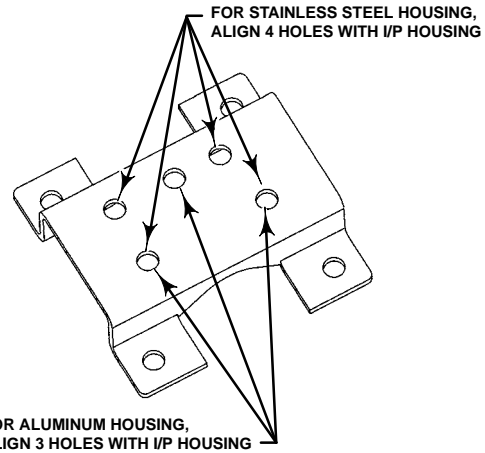
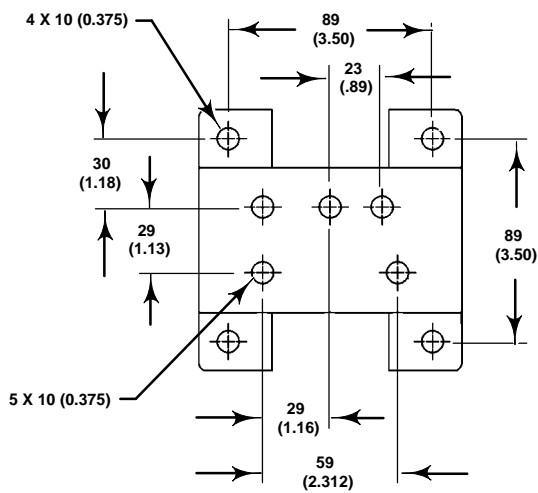

DETAIL "A" MOUNTING BRACKET

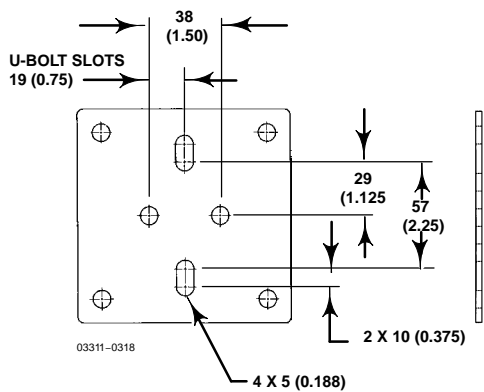

ADDITIONAL ADAPTOR PLATE (PART NUMBER 03311-0318-0001)
REQUIRED FOR I/P WITH STAINLESS STEEL HOUSING

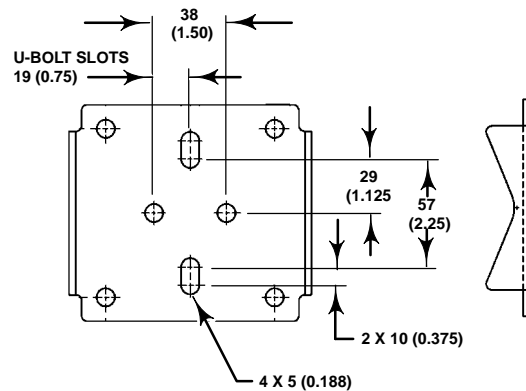

DETAIL "B" ADAPTER PLATE

mm
(INCH)

NOTES:

1. ATTACH THE BRACKET SHOWN IN DETAIL "A" TO THE TRANSDUCER
2. ATTACH THE ADAPTER PLATE SHOWN IN DETAIL "B" TO THE VALVE OR PIPE.
3. CONNECT THE TWO PIECES.

34B4990-C
34B5000-B
E0787

Figure 2-3. Typical Transducer Mounting with Universal Mounting Bracket (Continued)

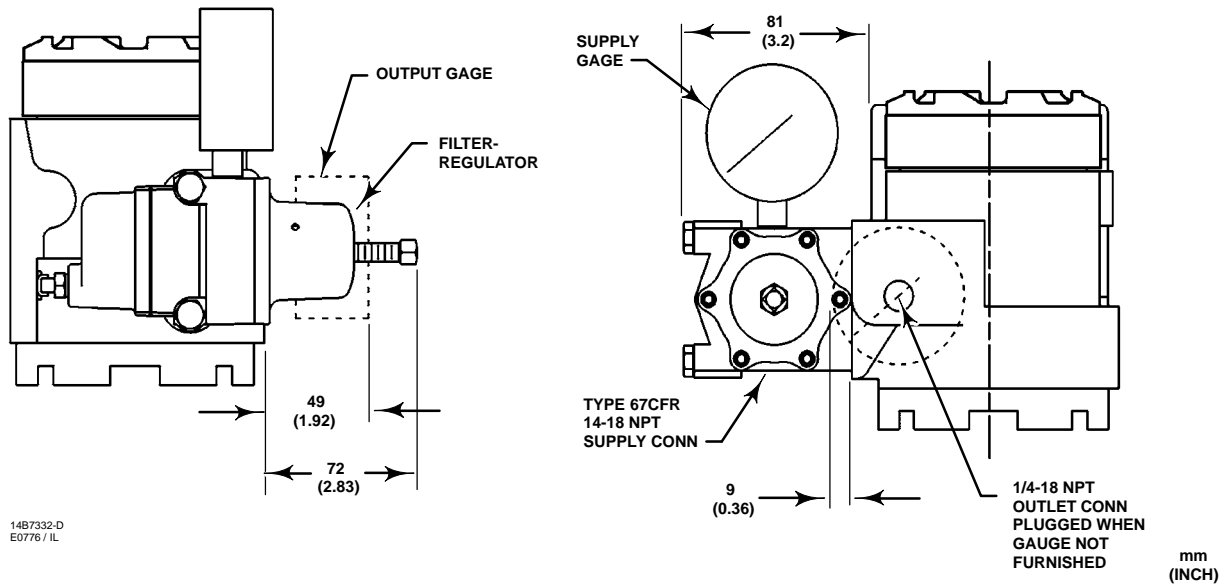

Figure 2-4. Typical Transducer Dimensions with Gauges

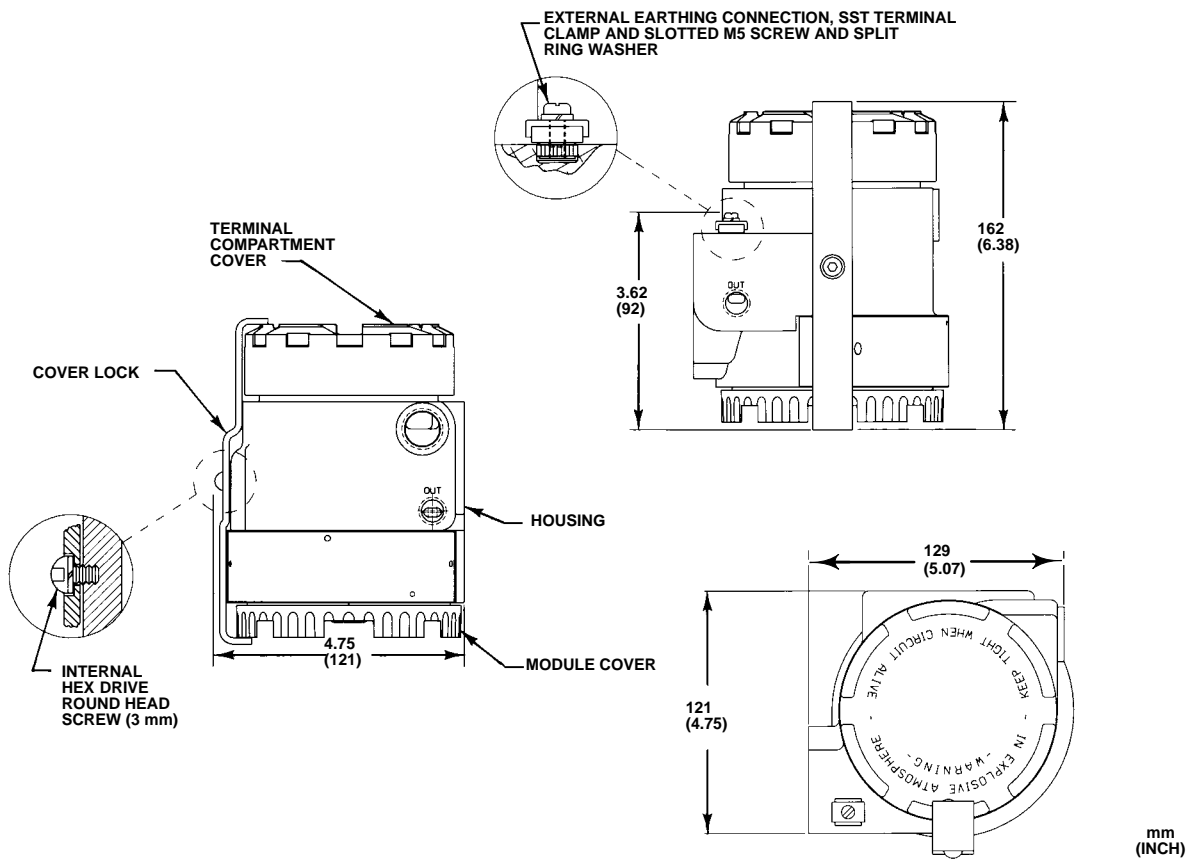

Figure 2-5. Transducer Dimensions with ATEX / IECEx Flameproof Certifications

3311 Transducers

Stroke Port

The constant bleed of supply medium from the pilot stage is directed out the stroke port, which is a screened hole located at the center of the module cover. Figure 2-1 shows the location of the stroke port.

Before installing the transducer, ensure the stroke port is clear. Do not mount the transducer in a location where foreign material may cover the stroke port. For information on using the stroke port, refer to the Troubleshooting section.

Exhaust Port

The transducer exhausts through a screened port located beneath the instrument nameplate. Figure 2-1 shows the location of the exhaust port. The

nameplate holds the screen in place. Exhaust will occur with a reduction in output pressure. The transducer should not be mounted in a location where foreign material may clog the exhaust port.

Signal Interruption

Upon loss of input current, or if input current decreases below 3.3 ± 0.3 mA, the output of the direct action unit will decrease to less than 0.1 bar (1 psi).

In the same situation, the output of the reverse action unit will increase to near supply pressure.

Section 3 Calibration

 **WARNING**

The following calibration procedures require taking the transducer out of service. To avoid personal injury and property damage caused by an uncontrolled process, provide some temporary means of control for the process before taking the transducer out of service. Also refer to the **WARNING** at the beginning of the Maintenance section.

 **WARNING**

Personal injury or property damage may result from fire or explosion when removing the final module assembly during any of the calibration procedures when natural gas is used as the supply medium. Ensure that the supply is shut-off and preventative measures are taken, such as adequate ventilation and the removal of any ignition sources, before performing any of the following calibration procedures.

Calibration of Type 3311 requires either an accurate current generator or an accurate voltage generator with a precision 250-ohm, 1/2-watt resistor. Figure 3-1 shows how to connect either device.

Calibration also requires a precision output indicator and a minimum nonsurging air supply of 5.0 normal m³/hr (187 scfh) at 1.4 bar (20 psi) for standard performance units. For multirange performance units, the air supply must be at least 0.2 bar (3 psi) greater than the maximum calibrated output pressure, up to 2.4 bar (35 psi) maximum.

For ease of calibration, the output load volume, including the output tubing and output indicator, should be a minimum of 33 cm³ (2 cubic inches). Review the information under Signal Interruption in the Installation section before beginning the calibration procedure.

Before calibration, determine the type of input (full or split range), and the type of output action (direct or

reverse). Consult the factory for split range output calibration. Also, determine if the unit offers standard or multirange performance. The unit supports eight basic input/output combinations:

Standard Performance

- Full Range Input, Direct Action
- Split Range Input, Direct Action
- Full Range Input, Reverse Action
- Split Range Input, Reverse Action

Multirange Performance

- Full Range Input, Direct Action
- Split Range Input, Direct Action (see note below)
- Full Range Input, Reverse Action
- Split Range Input, Reverse Action (see note below)

Note

Consult your Emerson Process Management sales office or the factory for calibration of multirange performance units with split range input or split range output, or both.

Table 3-1 lists the various input and output ranges over which the unit may be calibrated.

The input range is selected by changing the position of a jumper located on the electronic circuit board.

Refer to Electronic Circuit Board in the Maintenance section, and figure 6-4 for the location and instruction on placement.

CAUTION

Excessive current can damage the transducer. Do not connect an input current of more than 100 mA to the transducer.

Table 3-1. Type 3311 I/P Rangeability Matrix

INPUT RANGE	OUTPUT PRESSURE RANGE (PSI) (PERFORMANCE CODE)															
	COMMON RANGES					MISC.		STD. SPLIT			HIGH RANGE SPLITS					
	3-15 (S,M)	.5-30 (M)	3-27 (M)	6-30 (M)	5-25 (M)	0.5-6 (S,M)	.5-18 (S,M)	3-9 (S,M)	9-15 (S,M)	.5-15 (S,M)	15-30 (M)	15-27 (M)	6-18 (S,M)	18-30 (M)	5-15 (S,M)	15-25 (M)
4-20	✓	✓	✓	✓	✓	D	✓	D	D	✓	U	U	✓	U	✓	U
4-12	✓	✓	✓	✓	✓	D	✓	D	D	✓	U	U	✓	U	✓	U
12-20	✓		J	J	J	D	J	D	D	J	✓	✓	✓	✓	✓	✓
4-8	✓					✓		✓	✓				✓		✓	
8-12	✓					✓		✓	✓				✓		✓	
12-16	J					J		J	✓				J		J	
16-20	J					J		J	J				J		J	
10-50	Consult I/P Marketing															
S=Standard Performance Unit M=Multirange Performance Unit ✓=Available in Direct or Reverse Action D=Available in Direct Action Only J=Available, but if the desired calibration cannot be achieved by adjusting the zero/span screws, unit may require Hi/Lo jumper to be moved. The jumper is located on the circuit board assembly, and is usually in the Hi position. Disengaging the master module and moving the jumper to the Lo position will allow calibration to the desired range. U=Special Build Required.																

ADJUST THE CURRENT SOURCE TO PROVIDE THE 4 AND 20 mA SET POINTS

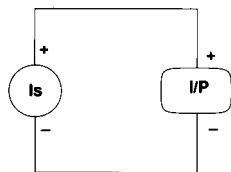

CALIBRATION USING A CURRENT SOURCE

TO OBTAIN THE 4 AND 20 mA SET POINTS, ADJUST THE VOLTAGE SOURCE (Vs) SO THE VOLTMETER (Vm) READS 1 AND 5 VOLTS, RESPECTIVELY, ACROSS THE 250 ohm RESISTOR

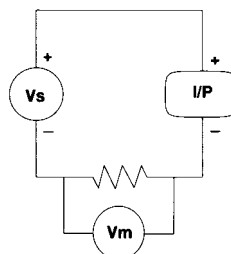

CALIBRATION USING A VOLTAGE SOURCE

Figure 3-1. Connecting a Current or Voltage Source for Calibration

Standard Performance: Full Range Input, Direct Action

WARNING

Refer to the **WARNING** at the beginning of the Maintenance section.

Use the following procedure to achieve a standard 0.2 to 1.0 bar (3 to 15 psi) output span for a 4 to 20 mA input signal:

1. Remove the module final assembly from the housing. Refer to Removing the Module Final Assembly in the Maintenance section for an explanation of how to disengage the module final assembly.
2. Confirm that the unit is direct acting. A green electronic circuit board identifies direct-acting units. Refer to Action under the heading Electronic Circuit Board in the Maintenance section for more information on direct acting units.
3. Position the range jumper in the Hi position for High Range. Figure 6-4 shows the circuit board jumper positions.
4. Replace the module final assembly in the housing. Refer to Replacing the Module Final Assembly in the Maintenance section for an explanation of how to engage the module final assembly.
5. Connect the air supply to the air supply port.
6. Connect a precision output indicator to the output signal port.

7. Make sure that the output gauge port has an output gauge or a threaded plug installed. A threaded plug is provided for units shipped without output gauges.
8. Remove the terminal compartment cover.
9. Connect the current source (or voltage source) positive lead (+) to the terminal block positive (+) and the current source (250-ohm resistor lead) negative lead (-) to the terminal block negative (-). Refer to figure 3-1.

CAUTION

Excessive current can damage the transducer. Do not connect an input current of more than 100 mA to the transducer.

10. Apply a 4.0 mA ($V_m = 1.0$ V) signal, and adjust the zero screw to achieve a 0.2 bar (3.0 psi) output. The output increases with clockwise rotation of the zero screw.
11. Apply a 20.0 mA ($V_m = 5.0$ V) signal, and adjust the span screw to achieve a 1.0 bar (15.0 psi) output. The output increases with clockwise rotation of the span screw.
12. Repeat steps 10 and 11 to verify and complete the calibration.

Multirange Performance: Full Range Input, Direct Action

 **WARNING**

Refer to the WARNING at the beginning of the Maintenance section.

Note

Consult your Emerson Process Management sales office or the factory for calibration of multirange performance units with split range input.

Use the following procedure with a multirange performance unit to achieve the desired direct action output span for a 4 to 20 mA input signal:

1. Perform steps 1 through 9 of the calibration procedure for Standard Performance: Full Range Input, Direct Action.

2. Apply a 4.0 mA ($V_m = 1.0$ V) signal, and adjust the zero screw to achieve the desired lower limit of the output range. The lower limit must be between 0.03 and 0.6 bar (0.5 and 9.0 psi). The output increases with clockwise rotation of the zero screw.

3. Apply a 20.0 mA ($V_m = 5.0$ V) signal, and adjust the span screw to achieve the desired upper limit of the output range. The span must be at least 0.4 bar (6.0 psi). The maximum upper limit is 2.0 bar (30.0 psi). The output increases with clockwise rotation of the span screw.

4. Repeat steps 2 and 3 to verify and complete the calibration.

Standard Performance: Split Range Input, Direct Action

 **WARNING**

Refer to the WARNING at the beginning of the Maintenance section.

4 to 12 mA Input Signal

Use the following calibration procedure to produce a 0.2 to 1.0 bar (3 to 15 psi) output span for a 4 to 12 mA input signal:

1. Perform steps 1 through 9 of the calibration procedure for Standard Performance: Full Range Input, Direct Action.
2. Apply an input of 4.0 mA ($V_m = 1.0$ V), and adjust the zero screw to achieve an output of 0.2 bar (3.0 psi).
3. Apply an input of 12.0 mA ($V_m = 3.0$ V), and adjust the span screw to achieve an output of 1.0 bar (15.0 psi).
4. Repeat steps 2 and 3 to verify and complete the calibration.

3311 Transducers

12 to 20 mA Input Signal

Use the following calibration procedure to produce a 0.2 to 1.0 bar (3 to 15 psi) output span for a 12 to 20 mA input signal:

Note

There may be some span interaction with zero in this range, and the following steps compensate for this.

1. Perform steps 1 through 9 of the calibration procedure for Standard Performance: Full Range Input, Direct Action.
2. Apply an input of 4.0 mA ($V_m = 1.0$ V), and adjust the zero screw to achieve an output of 0.2 bar (3.0 psi).
3. Apply an input of 12.0 mA ($V_m = 3.0$ V), and adjust the span screw to achieve an output of 1.0 bar (15.0 psi).
4. Maintain the input of 12.0 mA ($V_m = 3.0$ V), and adjust the zero screw to achieve an output of 0.2 bar (3.0 psi). The unit may not turn down this low; if it does not, go to step 7.
5. If the output reaches 0.2 bar (3.0 psi) in step 4, apply an input of 20.0 mA ($V_m = 5.0$ V) and note the error (the actual reading versus 15.0 psi). Adjust the span screw to overcorrect the error by a factor of two. For example, if the reading was 0.9 bar (14.95 psi), adjust the span screw to achieve an output of 1.1 bar (15.05 psi).
6. Repeat steps 4 and 5 to verify and complete the calibration.
7. Turn off the air supply. Remove the module final assembly from the housing. Place the range jumper in the Lo position for Low Range, as indicated in figure 6-4. Replace the module final assembly. Turn on the air supply.
8. Apply an input of 12.0 mA ($V_m = 3.0$ V), and adjust the zero screw to achieve an output of 0.2 bar (3.0 psi).
9. Apply an input of 20.0 mA ($V_m = 5.0$ V), and note the error (the actual reading versus 15.0 psi). Adjust the span screw to overcorrect the error by a factor of two. For example, if the reading was 0.9 bar (14.95 psi), adjust the span screw to achieve an output of 1.1 bar (15.05 psi).
10. Repeat steps 8 and 9 to verify and complete the calibration.

Standard Performance: Full Range Input, Reverse Action

WARNING

Refer to the WARNING at the beginning of the Maintenance section.

Use the following procedure on reverse action units to achieve a 1.0 to 0.2 bar (15 to 3 psi) output span for a 4 to 20 mA input signal:

1. Perform steps 1 through 9 under Standard Performance: Full Range Input, Direct Action, except for step 2. In place of step 2, confirm that the unit is reverse acting. A red electronic circuit board identifies reverse-acting units. Refer to Action under the heading Electronic Circuit Board in the Maintenance section for more information on reverse acting units.
2. Apply an input of 4.0 mA ($V_m = 1.0$ V), and adjust the zero screw to achieve an output of 1.0 bar (15.0 psi).
3. Apply an input of 20.0 mA ($V_m = 5.0$ V), and adjust the span screw to achieve an output of 0.2 bar (3.0 psi).
4. Repeat steps 2 and 3 to verify and complete the calibration.

Multirange Performance: Full Range Input, Reverse Action

WARNING

Refer to the WARNING at the beginning of the Maintenance section.

Note

Consult your Emerson Process Management sales office or the factory for calibration of multirange performance units with split range input.

Use the following procedure with a multirange unit to achieve the desired reverse action output span for a 4 to 20 mA input signal:

1. Perform steps 1 through 9 of the calibration procedure for Standard Performance: Full Range Input, Direct Action, except for step 2. In place of step 2, confirm that the unit is reverse acting. A red

electronic circuit board identifies reverse-acting units. Refer to Action under the heading Electronic Circuit Board in the Maintenance section for more information on reverse acting units.

2. Apply an input of 4.0 mA ($V_m = 1.0$ V), and adjust the zero screw to achieve the desired upper limit of the output range. The 4 mA point must be between 0.6 and 2.0 bar (9.0 and 30.0 psi). The output increases with clockwise rotation of the zero screw.
3. Apply an input of 20.0 mA ($V_m = 5.0$ V), and adjust the span screw to achieve the desired lower limit of the output range. The span must be at least 0.7 bar (11.0 psi). The lower limit of the 20.0 mA setting is 0.03 bar (0.5 psi). The output increases with clockwise rotation of the span screw.
4. Repeat steps 2 and 3 to verify and complete the calibration.

Standard Performance: Split Range Input, Reverse Action



WARNING

Refer to the **WARNING** at the beginning of the Maintenance section.

4 to 12 mA Input Signal

Use the following procedure on reverse action units to achieve a 1.0 to 0.2 bar (15 to 3 psi) output signal for a 4 to 12 mA input signal:

1. Perform steps 1 through 9 of the calibration procedure for Standard Performance: Full Range Input, Direct Action, except for step 2. In place of step 2, confirm that the unit is reverse acting. A red electronic circuit board identifies reverse-acting units. Refer to Action under the heading Electronic Circuit Board in the Maintenance section for more information on reverse acting units.
2. Apply an input of 4.0 mA ($V_m = 1.0$ V), and adjust the zero screw to achieve an output of 1.0 bar (15.0 psi).
3. Apply an input of 12.0 mA ($V_m = 3.0$ V), and adjust the span screw to achieve an output of 0.2 bar (3.0 psi).
4. Repeat steps 2 and 3 to verify and complete the calibration.

12 to 20 mA Input Signal

Use the following procedure on reverse action units to achieve a 1.0 to 0.2 bar (15 to 3 psi) output signal for a 12 to 20 mA input signal:

Note

There may be some span interaction with zero in this range, and the following steps compensate for this.

1. Perform steps 1 through 9 of the calibration procedure for Standard Performance: Full Range Input, Direct Action, except for step 2. In place of step 2, confirm that the unit is reverse action. A red electronic circuit board identifies reverse-acting units. Refer to Action under the heading Electronic Circuit Board in the Maintenance section for more information on reverse acting units.
2. Apply an input of 4.0 mA ($V_m = 1.0$ V), and adjust the zero screw to achieve an output of 1.0 bar (15.0 psi).
3. Apply an input of 12.0 mA ($V_m = 3.0$ V), and adjust the span screw to achieve an output of 0.2 bar (3.0 psi).
4. Maintain the input of 12.0 mA ($V_m = 3.0$ V), and adjust the zero screw to achieve an output of 1.0 bar (15.0 psi). The unit may not turn up this high; if it does not, go to step 7.
5. If the output reaches 15.0 psi in step 4, apply an input of 20 mA, and adjust the span screw to achieve a 3.0 psi output. Apply an input of 20 mA ($V_m = 5.0$ V), and note the error (the actual reading versus 3.0 psi). Adjust the span screw to overcorrect the error by a factor of two. For example, if the reading was 2.95 psi, adjust the span screw to achieve an output of 3.05 psi.
6. Repeat steps 4 and 5 to verify and complete the calibration.
7. If the 12.0 mA ($V_m = 3.0$ V) cannot be adjusted to 1.0 bar (15.0 psi) in step 4, turn off the air supply. Remove the module final assembly from the housing. Place the range jumper in the Lo position for Low Range, as shown in figure 6-4. Replace the module final assembly. Turn on the air supply.
8. Apply an input of 12.0 mA ($V_m = 3.0$ V), and adjust the zero screw to achieve an output of 1.0 bar (15.0 psi).
9. Apply an input of 20 mA ($V_m = 5.0$ V), and note the error (the actual reading versus 3.0 psi). Adjust the span screw to overcorrect the error by a factor of two. For example, if the reading was 2.95 psi, adjust the span screw to achieve and output of 3.05 psi.

3311 Transducers

10. Repeat steps 8 and 9 to verify and complete the calibration.

10–50 mA Input Signal

Use the previous procedures and replace 4–20 mA references with the appropriate 10–50 mA numbers; for example:

- 4 mA = 10 mA
- 12 mA = 30 mA
- 20 mA = 50 mA

Note

10–50 mA available only with direct acting units.

Transporting the Module Final Assembly

The transducer allows the module final assembly to be removed while the housing is in its installed position. In the event the transducer does not function properly, an operational module final assembly can be taken to the field and exchanged with the nonfunctional module.

After the transducer is calibrated in the shop, the module final assembly can be removed from the housing. At the time the span and zero screws disengage, there will be minimal effect on the calibrated span. The calibrated module can now be taken to the field. Ensure that the span and zero potentiometers are not moved from their calibrated positions.

Section 4 Principle of Operation

The following paragraphs describe the functional parts of the Type 3311. Figure 4-1 shows the block diagram.

Electronic Circuit

During operation, the input current signal is received by the transducer's electronic circuit and compared to the output pressure from the booster stage. A solid-state pressure sensor is part of the electronic circuit and monitors the booster stage output. The silicon-based sensor uses strain gauge thin film technology.

The sensors pressure signal is fed to a simple internal control circuit. By using this patented technique, the transducer's performance is set by the sensor/circuit combination. Changes in output load (leaks), variations in supply pressure, or even component wear are sensed and corrected by the sensor/circuit combination. Electronic feedback allows crisp dynamic performance and readily compensates for output changes induced by vibration.

Note

Because the transducer is electronic in nature, it is not well-modeled in the loop as a simple resistor in series with an inductor. It is better thought of as a 50-ohm resistor in series with a 6.0 V voltage drop, with negligible inductance.

This is important when calculating the loop load. When the transducer is used in series with a microprocessor-based transmitter, the noninductive nature of the transducer allows digital signals to successfully pass through undistorted.

Magnetic Actuator

The electronic circuit controls the level of current flowing through the actuator coil, which is located in the pilot/actuator assembly. A change to the level of coil current is made by the electronic circuit when it senses a discrepancy between the pressure measured by the sensor and the pressure required by the input signal.

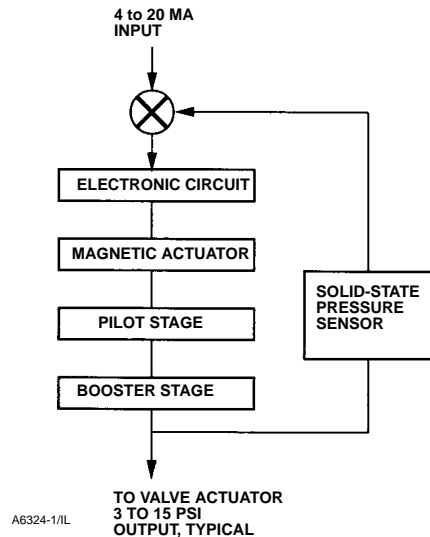

Figure 4-1. Functional Parts Block Diagram

The actuator performs the task of converting electrical energy (current) to motion. It uses a patented, coaxial moving magnet design optimized for efficient operation and is highly damped at its mechanical resonance. A silicone rubber diaphragm helps to protect its working magnetic gaps from contamination.

Pilot Stage

The patented pilot stage contains two opposed fixed nozzles: the supply nozzle and the receiver nozzle. It also contains the deflector, which is the moving element. See figures 4-2 and 4-3. The supply nozzle is connected to the supply air and provides a high-velocity air stream. The receiver nozzle captures the air stream and converts it back to pressure. The receiver nozzle pressure is the output pressure of the pilot stage.

To vary the pilot output pressure, the high-velocity stream is diverted away from the receiver nozzle by the deflector, which is a cylindrical, aerodynamic body located between the two nozzles.

In response to a change in actuator coil current, the deflector is repositioned between the nozzles. There is a linear relationship between the coil current and the pilot stage output pressure. For direct action units, the power-off, or fail-safe, position of the top of the deflector is near the center of the stream and results in nearly zero pilot output pressure. As the coil is energized, the deflector is drawn out of the stream.

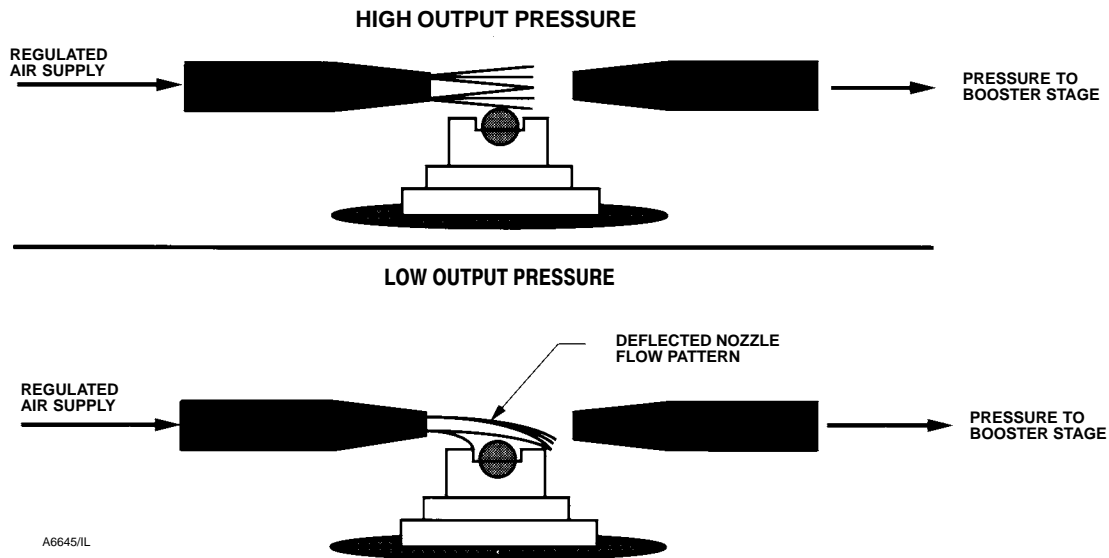
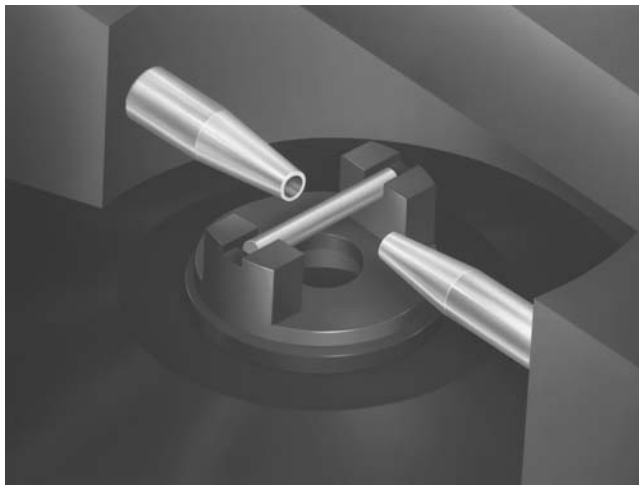

Figure 4-2. Deflector/Nozzle Pilot Stage Operation (Direct Action)



W6287/IL

Figure 4-3. Detail of Deflector/Nozzle Pilot Stage

For reverse action units, the power-off, or fail-safe, position of the deflector is completely out of the stream. The result is maximum pilot output pressure. As the coil is energized, the deflector moves into the stream, resulting in a decreased pilot output pressure.

The deflector material is tungsten carbide, and the nozzles are 316 stainless steel. The nozzles have a large bore of 0.41 mm (0.016 inches), which provides good resistance to plugging.

Booster Stage

The receiver nozzle pressure controls the booster stage, which has a poppet valve design. An increase in receiver nozzle pressure positions the valving in the booster stage to produce an increase in the transducer output signal. A decrease in the receiver nozzle pressure positions the valving in the booster stage to allow exhaust to occur, decreasing the output signal.

The booster stage operates using a 3:1 pressure gain from the pilot stage. High flow rate capability is achieved by large flow area poppet design and internal porting having low flow resistance. The booster stage design provides very good stability in high vibration applications, and the poppet valve technology provides resistance to plugging.

Section 5 Troubleshooting

The modular design and unitized subassemblies of the 3311 allows for quick and easy troubleshooting and repair. This section presents information on the diagnostic features and procedures for troubleshooting both models in service or in the shop.

Diagnostic Features

If a control loop does not perform properly and the cause of malfunction has not been determined, two features of the transducer can be used to determine if the transducer is at fault: the stroke port and Remote Pressure Reading.

Stroke Port

The stroke port provides a way to quickly increase the transducer output, giving a rough measure of the unit's functionality. A hole in the module cover vents the constant bleed from the pilot stage. When the hole is covered, pressure at the pilot stage receiver nozzle increases, which in turn increases the output. Output pressure will increase to within 2 psi of supply pressure for either direct or reverse action. If output pressure does not increase to this level, it may indicate that supply air is not reaching the pilot stage or that a pilot stage nozzle is plugged.

Note

If the stroke port diagnostic feature is not desired, the transducer is available with an optional cover that contains multiple stroke ports, as shown in figure 2-1. This prevents increasing the output by covering the stroke port.

Remote Pressure Reading (RPR)

Remote Pressure Reading (RPR) is an optional diagnostic feature that enables the user to determine the output pressure from any location along the signal wire path. For loop troubleshooting, this allows the user to confirm the functionality of the transducer from a remote location.

A frequency signal directly proportional to the output pressure is superimposed on the input signal loop.

The frequency range of the RPR function is 5,000 to 8,000 Hz.

A jumper on the circuit board activates the Remote Pressure Reading function. The Maintenance section provides instruction on positioning the jumper. The jumper, shown in figure 6-4, has two positions: N for ON, or D for OFF. The RPR jumper is in the N (ON) position when the unit ships from the factory, unless otherwise specified.

Using the HART® Communicator to Read the RPR Signal

Note

The 375 Field Communicator is not compatible with the 3311 transducer. The RPR feature can only be accessed using the 275 HART Communicator.

The 3311 transducer is not a HART instrument. The HART communicator is only used to access the RPR diagnostic.

The RPR frequency signal can be measured at any location along the two input wires using a HART Communicator. The HART Communicator displays both the output frequency in Hertz and the transducer output pressure in psi. Figure 5-1 shows the wiring connections.

The transducer is not a microprocessor-based transmitter and therefore does not identify itself to the HART Communicator. For this reason, the HART Communicator displays a screen telling the user it cannot verify that the transducer is on the loop.

Neither the HART Communicator nor the Remote Pressure Reading function are intended to be used for calibration. They are intended as a diagnostic feature. The accuracy of the Remote Pressure Reading function when used in conjunction with the HART Communicator is typically $\pm 3\%$ of span and a maximum of $\pm 6\%$ of span.

Note

When the output of a smart transmitter is used as the input to the transducer, the HART Communicator will not recognize the frequency signal of the transducer. Enabling the RPR feature on the transducer can

3311 Transducers



NOTE:
 1 IF A HART COMMUNICATOR IS NOT AVAILABLE, A FREQUENCY COUNTER CAN BE USED IN ITS PLACE. SEE TEXT TO CONVERT THE FREQUENCY DISPLAY TO OUTPUT PRESSURE

B2466/L

Figure 5-1. Wiring Connections for the HART® Communicator or a Frequency Counter

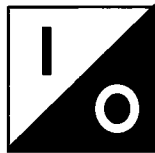

A6646

Figure 5-2. HART® Communicator ON/OFF Key

also cause errors when trying to communicate with a smart transmitter using a HART Communicator. For these reasons, you should disable the RPR feature on the transducer when using this type of loop.

Use the ON/OFF key (figure 5-2) to turn the HART Communicator on and off. When the communicator is turned on, it searches for a HART-compatible device on the 4 to 20 mA loop. If a device is not found, then the communicator displays the message, “No Device Found. Press OK.” Press **OK** to display the **Main** menu (figure 5-3).

If a HART-compatible device is found, the communicator displays the **Online** menu.

When the HART Communicator is not connected to a HART compatible device, the first menu to appear after powering is the **Main** menu.

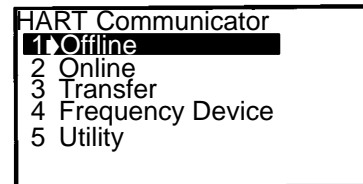

Figure 5-3. HART® Communicator Main Menu

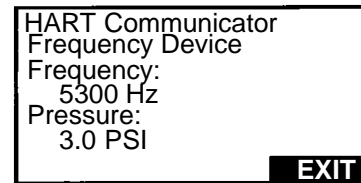

Figure 5-4. HART® Communicator Frequency Device Menu

From within the **Main** menu, you can access the **Frequency Device** menu (figure 5-4) by pressing the **4** key.

Using a Frequency Counter to Read the RPR Signal

A frequency counter also can be used for Remote Pressure Reading. The frequency counter displays the RPR output in the same manner as the HART Communicator, but the output frequency must be converted to output pressure using a simple mathematical formula. To determine the output pressure, subtract 5,000 Hz from the frequency

displayed on the frequency counter, and then divide by 100.

Conversion Formula

$$\frac{\text{Display Hz} - 5,000 \text{ Hz}}{100} = \text{psig}$$

Example:

$$\frac{5,311 \text{ Hz} - 5,000 \text{ Hz}}{100} = 3.11 \text{ psig}$$

Note

The Remote Pressure Reading (RPR) frequency signal has an amplitude of 0.4 to 1.0 V peak-to-peak. If other noise (frequency) with a comparable or greater amplitude is present on the line, it may make the RPR frequency signal unreadable.

In-service Troubleshooting

A number of simple checks can be made on the transducer while the unit is in service. Figure 5-5 shows a troubleshooting flowchart.

1. Make sure that the module cover is tight. The cover should be hand-tightened and then advanced 1/4 to 1/2 turn (24 to 27 N•m) (18 to 20 lbf•ft).
2. Confirm the general functionality of the unit by using the diagnostic features described earlier in this section.
3. Confirm that the filter-regulator is not full of water or oil and that supply air is reaching the unit. The air supply pressure should be at least 0.2 bar (3 psi) greater than the maximum calibrated output pressure.
4. Confirm that there are no major leaks in the output signal line or from the output gauge port.
5. Confirm that there are no obstructions and the screens are clean in the stroke port or the exhaust port.

 **WARNING**

Personal injury or property damage could result from an uncontrolled process. Unscrewing the module cover removes power from the electronics and the output signal will

be 0.0 psi. Before removing the module cover, ensure the process is properly controlled.

 **WARNING**

Personal injury or property damage could result from fire or an explosion. In explosive atmospheres, remove power and shut off the air supply to the transducer before attempting to remove the terminal compartment cover or module cover. Failure to do so could result in an electrical spark or explosion.

6. If applicable, remove the cover lock and screw to allow access to the terminal compartment cover.
7. Remove the terminal compartment cover (see Warning above), and use a milliammeter, or a digital voltmeter to confirm that proper input current is supplied to the transducer.
8. Remove the terminal compartment cover (see Warning above), and short the loop across the positive (+) and the negative (-) terminals to check the output. The output should be nearly 0 psi. If the output is not 0 psi, replace the module final assembly.
9. Remove the terminal compartment cover (see Warning above), and, using a digital voltmeter, check the voltage between the transducer positive (+) and negative (-) terminals. The voltage should measure 6.0 to 8.2 V. A lower voltage can indicate a short in the input wires or defective controller. No voltage can indicate an open circuit in the control loop. A voltage of greater than 8.5 volts indicates a problem with the transducer, a faulty or corroded connection at the transducer, or an overcurrent condition. Replace the module final assembly. If the voltage is still not in the proper range (6.0 to 8.2 V), remove the terminal block and terminal block connection board. Apply power to the electrical feedthroughs. (Note the polarity of the feedthroughs, shown in figure 6-8.) Recheck the voltage. If the voltage is in the proper range, replace the terminal block and terminal block connection board. If the voltage is still not in the proper range, replace the housing.
10. Prepare to remove the module final assembly from the housing, or to remove the transducer from its mounting bracket. Refer to Module Final Assembly in the Maintenance section for instructions on removing the module final assembly from the module housing.

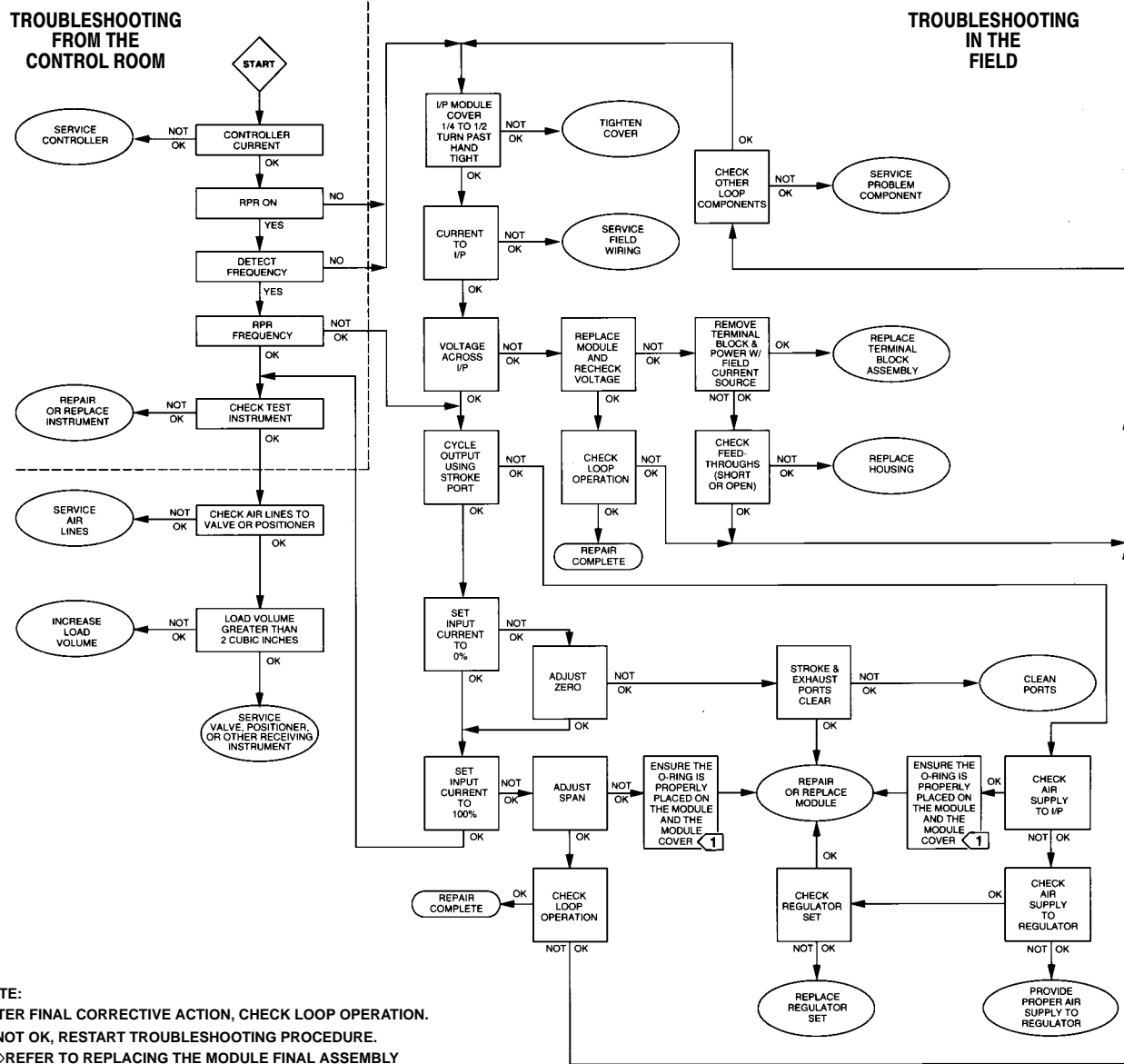

NOTE:
 AFTER FINAL CORRECTIVE ACTION, CHECK LOOP OPERATION.
 IF NOT OK, RESTART TROUBLESHOOTING PROCEDURE.
 1) REFER TO REPLACING THE MODULE FINAL ASSEMBLY
 IN SECTION 6.

C0789/IL

Figure 5-5. Field Troubleshooting Flowchart

WARNING

Personal injury or property damage could result from an uncontrolled process. Unscrewing the module cover removes power from the electronics and the output signal will be 0.0 psi. Before removing the

module cover, ensure the process is properly controlled.

With the module final assembly removed from the housing, the following checks can be made.

1. Review the position of the Remote Pressure Reading jumper (if so equipped) and range jumper to confirm that they are placed in the desired position. Refer to Electronic Circuit Board in the

Maintenance section, and figure 6-4 for the location of these jumpers and instructions on placement.

2. Observe the position and condition of the three module O-rings to confirm they make a tight seal.
3. Verify that the O-ring is correctly positioned in the groove on the flat face of the module cover. Refer to figure 6-8 for an exploded view.
4. Inspect the porting on the module final assembly to determine if large amounts of contaminants have entered the transducer.

Before making the following checks, disconnect both signal wires from the transducer, and ensure the module final assembly is removed from the housing.

1. Using an ohmmeter, check the electrical connections in the housing terminal compartment. The circuit should show an open between the positive (+) and negative (-) terminals. If not, replace the housing or terminal block and connection board.
2. Use a wire jumper to connect the two electrical feedthroughs located in the module compartment. The resistance between the positive (+) and negative (-) terminals in the terminal compartment should be 10 ohms. If not, check the electrical feedthroughs for short or open circuits. If a short or open circuit is found, replace the housing.
3. With the electrical feedthroughs jumpered as stated above, connect the ohmmeter to either the positive (+) or negative (-) terminal and the grounding lug. The circuit should show an open. If not, check for a short to the housing.
4. Remove the module from the module cover and inspect the pilot/actuator assembly for damage or clogging.

Some of the previous troubleshooting steps may be inconvenient to perform in the field. It may be best to make use of the modular design of the Type 3311 and keep a spare, calibrated module final assembly available for exchange. If the module final assembly is to be transported to the shop for repair, first remove it from the module cover. Attach the spare module final assembly to the module cover. Refer to Module Final Assembly in the Maintenance section for complete instructions. The nonfunctioning module can then be returned to the shop for troubleshooting.

Troubleshooting in the Shop

If the entire transducer is brought to the shop for troubleshooting, then the preceding sequence

applies. If only the module final assembly has been brought to the shop, then use another Type 3311 housing as a test fixture. Insert the module into the test fixture. Perform the previous steps (as they apply) of the In-service Troubleshooting procedure.

To further aid troubleshooting, the module final assembly can be broken down into three subassemblies. The troubleshooting sequence consists of exchanging the subassemblies with known working ones to determine which is at fault. The three subassemblies are the pilot/actuator assembly, the electronic circuit board, and the module subassembly. The module subassembly consists of the module final assembly with both the pilot/actuator assembly and electronic circuit board removed.

1. Remove the pilot/actuator assembly. Refer to Pilot/Actuator Assembly in the Maintenance section for complete removal information.
 - a. Inspect the nozzles and deflector. If they show a buildup of contaminants, clean the nozzles by **gently** inserting a wire with a maximum diameter of 0.38 mm (0.015 inches). Clean the deflector, if necessary, by spraying with contact cleaner.

CAUTION

Do not apply force to the deflector bar while cleaning the nozzles. Doing so could alter the alignment or disable the deflector bar mechanism.

CAUTION

Do not use chlorinated solvents for cleaning the pilot/actuator assembly. The chlorinated solvents will deteriorate the rubber diaphragm.

- b. Make sure the O-rings are lightly lubricated with silicone grease and properly seated.
- c. Reassemble and check operation.
- d. If after cleaning the transducer does not function, replace the pilot/actuator assembly with a new one.
- e. Reassemble and check operation.

3311 Transducers

2. Remove the electronic circuit board from the module final assembly. The Maintenance section describes how to remove the board.
 - a. Inspect the O-rings around the sensor for damage and replace them if necessary.
 - b. Check the sensor port and areas around the sensor for foreign material, and clean if necessary.
 - c. Reassemble and check operation.
 - d. If the transducer does not function, replace the electronic circuit board with a new one. Refer to Electronic Circuit Board in the Maintenance section for complete removal information.
 - e. Reassemble and check operation.
3. The module subassembly is aligned at the factory and should not be further disassembled. If the above steps fail to produce a working unit, the module subassembly is faulty and should be replaced.

Section 6 Maintenance

This Section describes the major components, assembly, and disassembly of the Type 3311 current-to-pressure transducers.

WARNING

To avoid personal injury or property damage from the sudden release of pressure, air, or natural gas:

- Always wear protective clothing, gloves, and eyewear when performing any maintenance operations.
- Disconnect any operating lines providing air pressure, electric power, or a control signal to the actuator. Be sure the actuator cannot suddenly open or close the valve.
- Use bypass valves or completely shut off the process to isolate the valve from process pressure. Relieve process pressure on both sides of the valve.
- Use lock-out procedures to be sure that the above measures stay in effect while you work on the equipment.
- Check with your process or safety engineer for any additional measures that must be taken to protect against process media.

WARNING

Personal injury or property damage may result from fire or explosion when removing the final module assembly during any of the Maintenance procedures when natural gas is used as the supply medium. Ensure that the supply is shut-off and preventative measures are taken, such as adequate ventilation and the removal of any

ignition sources, before removing the final module assembly in the following Maintenance procedures.

WARNING

The presence of Emerson Process Management personnel and approval agency personnel may be required if you service (other than normal, routine maintenance, such as calibration) or replace components on a Type 3311 transducer that carries a third-party approval. When replacing components, use only components specified by the factory. Substitution with other components may void the third-party approval and result in personal injury or property damage.

Use only the procedures, and component replacement techniques specifically referenced in this manual. Unauthorized procedures and improper techniques can cause poor quality repairs, impair the safety features of the device, and affect product performance and the output signal used to control a process.

Module Final Assembly

WARNING

Refer to the Maintenance WARNINGS at the beginning of this section.

The active mechanical and electrical components of the transducer are incorporated into a single, field-replaceable module called the module final assembly, as shown in figure 6-1. Electrical connection between the terminal compartment and module final assembly is made by electrical feedthroughs that extend into the module compartment. The feedthroughs enter sockets on the electronic circuit board. The span and zero screws extend through the terminal compartment wall into the module compartment. Connection to the span and zero potentiometers on the electronic circuit board is made by hook and loop fasteners.

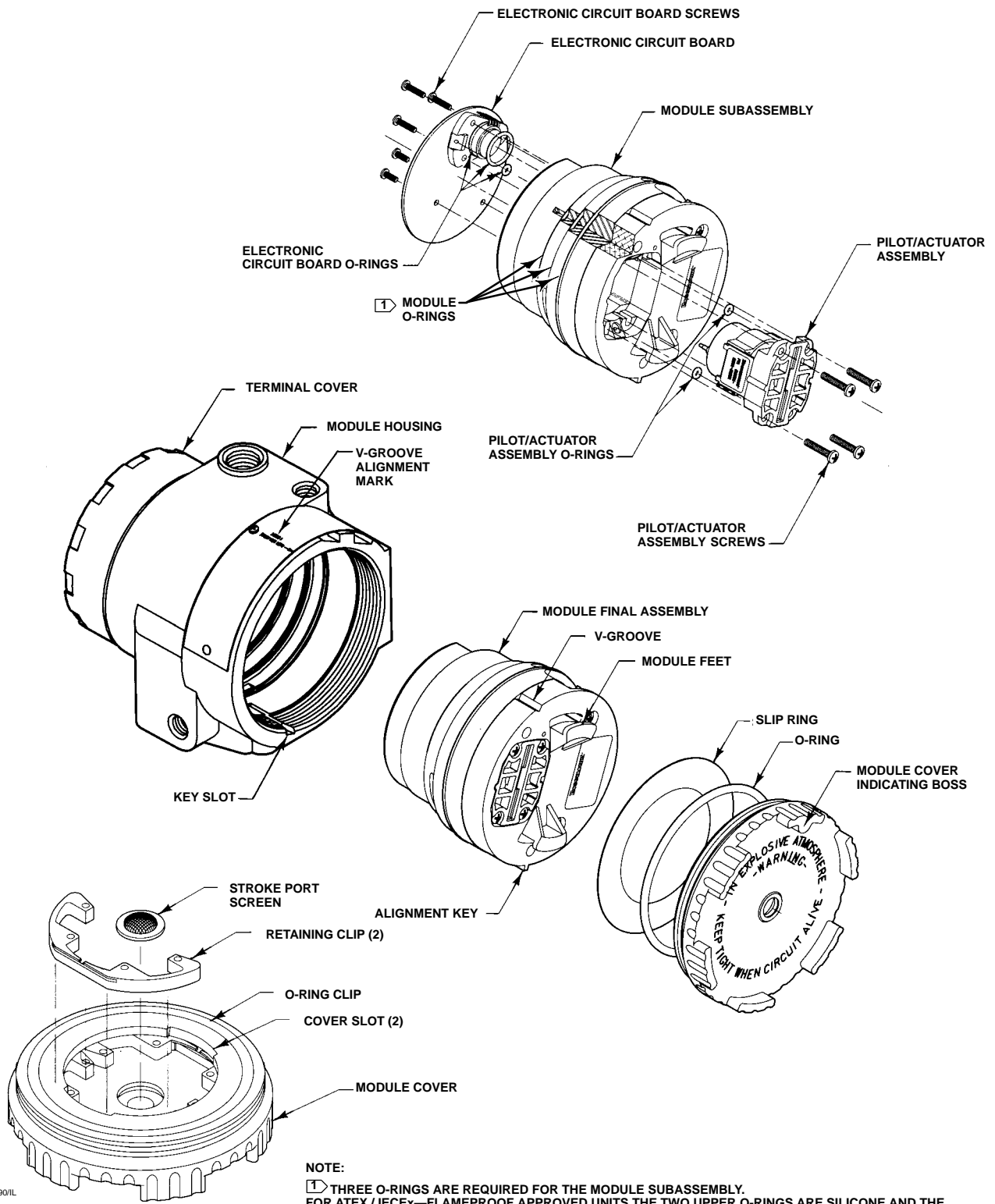

Figure 6-1. Type 3311 Exploded View

The module final assembly has three separate radial ports. The upper port is for supply air, the middle port for the output signal, and the lower ports for exhaust. Three O-rings separate the ports. The two lower O-rings are the same size, and the upper O-ring is slightly smaller. Table 6-1 shows O-ring sizes.

The module final assembly is attached to the module cover, which allows insertion and removal, and can be separated from the module cover for further disassembly. A module cover O-ring provides a seal between the module cover and module final assembly. Table 6-1 shows the O-ring sizes. A slip ring is located around the module feet. It allows the module cover to turn easily when the module final assembly is being removed from the housing.

The module final assembly consists of three major subassemblies, as shown in figure 6-1. They are the electronic circuit board, pilot/actuator assembly, and module subassembly.

Removing the Module Final Assembly

The module final assembly is attached to the module cover. Removing the module cover automatically removes the module final assembly from the housing. When the module cover is unscrewed, the electrical feedthroughs and span and zero adjustments automatically disengage. The internal air ports are also disengaged. The air supply to the transducer should be turned off to prevent uncontrolled air loss through the housing.

Table 6-1. O-Ring Sizes

DESCRIPTION	QTY.	SIZE
Module O-rings	1	043
	2	042
Pilot/Actuator O-rings	2	006
Circuit Board O-rings	2	016
	1	005
Module Cover O-ring	1	238
Terminal Cover O-ring	1	238
Filter-Regulator O-ring	1	114

 **WARNING**

Personal injury or property damage could result from fire or an explosion. In explosive atmospheres, remove power and shut off the air supply to the transducer before attempting to remove the terminal compartment cover or module cover. Failure to do so could result in an electrical spark or explosion.

Use the following steps to remove the module final assembly from the housing and module cover:

1. Shut off the air supply. If applicable, remove the cover lock and screw to allow access to the terminal compartment cover. Unscrew the module cover. When the module cover threads clear the housing, slowly pull on the cover, and the module final assembly will gradually come out of the housing.

Note

The module and the housing are designed for minimal clearance; therefore, patience may be required while pulling on the cover. Time must be allowed for release of the vacuum effect between the housing and module. If the module becomes tilted and cannot be removed, reinsert it completely into the housing and fully engage the module cover threads. Then proceed again with removal, ensuring that you pull slowly in a straight line.

 **WARNING**

Personal injury or property damage could result from an uncontrolled process. Unscrewing the module cover removes power from the electronics and the output signal will be 0.0 psi.

Refer to the WARNING at the beginning of this section before removing the module cover to ensure the process is properly controlled.

3311 Transducers

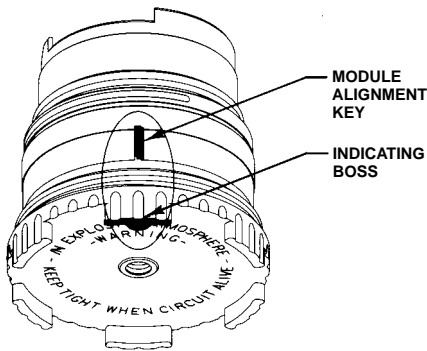

Figure 6-2. Alignment Key Above Module Cover Indicating Boss

Support both the module cover and the module final assembly as it comes out of the housing. This is to prevent dropping them, should they become detached accidentally.

WARNING

Do not grip the module cover threads. The threads are sharp and may cause minor injury. Wear gloves when removing the module cover.

2. Prepare to remove the module final assembly from the module cover. Align the module feet with the two interior cover slots. To accomplish this, identify the indicating boss on the module cover, shown in figure 6-2.

Grasp the module cover with one hand and the module final assembly with the other hand. Rotate the module final assembly so that the module alignment key is directly above the indicating boss on the module cover. Figure 6-2 shows the module alignment key and the indicating boss. The module feet are now aligned with the cover slots.

3. Remove the module final assembly from the module cover. To accomplish this, hold the cover steady, and push the module final assembly in the direction of the module cover indicating boss. At the same time, lift the opposite foot of the module final assembly out of the cover slot, as shown in figure 6-3.

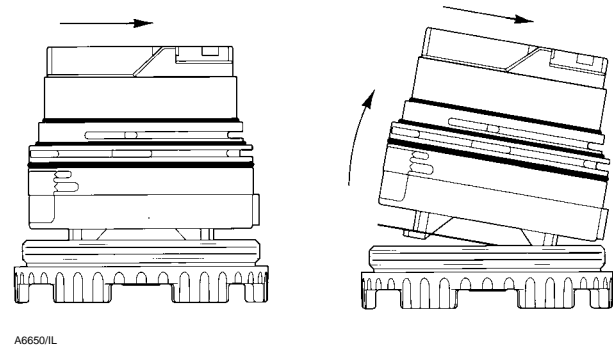

Figure 6-3. Removing the Module Final Assembly from the Module Cover

Replacing the Module Final Assembly

Use the following procedure to attach the module cover and replace the module final assembly:

1. Ensure that the electronic circuit board and the pilot actuator assembly provide the desired action (direct or reverse). See the Electronic Circuit Board and Pilot/actuator Assembly Action descriptions later in this section.
2. Ensure that the slip ring is in place around the feet of the module final assembly. The module cover O-ring should be lightly lubricated with silicone grease and placed in the O-ring gland. The stroke port screen should be clean and in place.

Note

The module cover O-ring must be in the O-ring gland, not down on the threads of the cover. This will ensure proper sealing of the pilot pressure area.

3. Position the retaining clips in the module cover so they are ready to accept the feet of the module final assembly. Ensure the leaves on the retaining clips are facing up. Figure 6-1 shows the correct orientation.
4. Insert one of the module feet into a cover slot, and push on the module final assembly to compress the retaining clip. Insert the opposite foot into the opposite cover slot, and rotate the module 90 degrees in the module cover to secure it in place.
5. Ensure that the three module O-rings are in the O-ring glands and are lightly lubricated with silicone grease. Inspect the O-rings to ensure that they are not twisted or stretched.
6. Apply lubricant to module cover threads for ease of assembly.

7. Prepare to insert the module into the housing. Align the V-groove located on the module final assembly with the indicating mark located on the nameplate. This positions the alignment key with the key slot. Figure 6-1 shows the location of the V-groove and the indicating mark.

8. Insert the module, engage the module cover threads, and screw on the module cover. The module final assembly will automatically engage the electrical feedthroughs and span and zero screws.

9. Hand tighten the module cover as much as possible. Use a wrench or long screwdriver shaft to tighten the module cover an additional 1/4 to 1/2 turn [24 to 27 N•m (18 to 20 lbf•ft)]. For units with ATEX/IECEX Flameproof approvals, make sure the cover lock and screw have been securely re-installed. The screw accepts a 3 mm hex drive.

Note

When the module cover is tightened, connection is made with the electrical feedthroughs and span and zero screws, and the module final assembly O-rings become seated. Failure to fully tighten the module cover may prevent the transducer from operating properly.

Electronic Circuit Board



Refer to the Maintenance WARNINGS at the beginning of this section.

The electronic circuit board is located on top of the module final assembly, as shown in figure 6-1. Beneath the circuit board and permanently attached to it is the pressure sensor. Two jumpers on the circuit board control various functions of the transducer. Figure 6-4 shows the location of these jumpers.

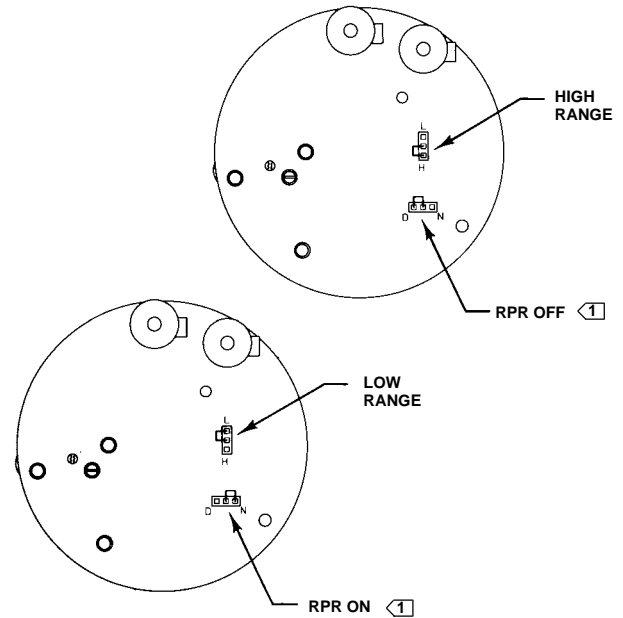

NOTE:
 [1] RPR JUMPER ONLY ON UNITS WITH REMOTE PRESSURE READING (RPR) OPTION
 A6652/L

Figure 6-4. Circuit Board Jumper Positions

Optional Remote Pressure Reading (RPR) Jumper

Remote Pressure Reading (RPR) is an optional diagnostic feature that enables the operator to determine the transducer output signal from any location along the signal wire path. The transducer generates a frequency signal that can be received by a HART Communicator or a frequency counter. Operation of the RPR feature is jumper-selectable, in units so equipped. The RPR feature operates when the jumper is located in the N position on the circuit board. With the jumper in the D position, the RPR feature does not operate. When the RPR feature is included, the transducer is shipped with the RPR jumper in the N position, unless otherwise specified. For more information about the RPR feature, refer to Remote Pressure Reading (RPR) in the Troubleshooting section.

Note

When operating Type 3311 transducers in series, only one unit may be configured for Remote Pressure Reading. Activating the RPR feature in two units will result in an unusable RPR signal.

3311 Transducers

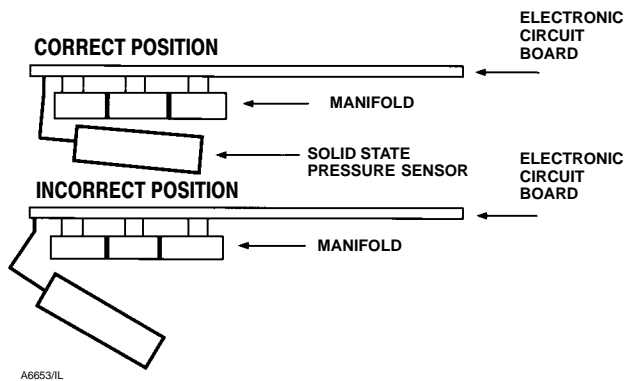

Figure 6-5. Positioning the Pressure Sensor

Range Jumper

The range jumper is positioned according to the calibration specified. All full span calibrations and some split range calibrations can be accomplished with the range jumper in the High Range position. Some split range calibrations require the jumper to be in the Low Range position. For more information about the range jumper, refer to Standard Performance: Split Range Input, Direct Action in the Principle of Operation section.

Action

For direct action units, output changes directly with a corresponding change in input. For example, as the input increases from 4 to 20 mA the output increases from 0.2 to 1.0 bar (3 to 15 psi). Direct action circuit boards are green in color.

For reverse action units, output changes inversely with a change in input. For example, as the input increases from 4 to 20 mA the output decreases from 1.0 to 0.2 bar (15 to 3 psi). Reverse action circuit boards are red in color.

Upon loss of input current, or if input current decreases below 3.3 ± 0.3 mA, the output of the direct action unit decreases to less than 0.1 bar (1 psi). In the same situation, the output of the reverse action unit increases to near supply pressure.

Removing the Electronic Circuit Board

The electronic circuit board is connected to the module final assembly by five mounting screws. The circuit board must be removed to inspect the pressure sensor located beneath it. To remove the circuit board, remove the five mounting screws and pull upward on the plastic board standoff (black=multirange; white=standard).

CAUTION

Standard electronic assembly handling procedures apply. Do not attempt to remove the circuit board by pulling on the components. Doing so could weaken the connections and disable the electronics.

Be careful when handling the pressure sensor located beneath the circuit board. The pressure sensor lead frame is bent to allow the pressure sensor to fit properly in the sensor cavity of the module final assembly, and to maintain flush contact with the pressure sensor manifold.

Three O-rings accompany the pressure sensor. Two O-rings of the same size are located on each side of the pressure sensor. A third, smaller O-ring is positioned in the beveled O-ring gland of the module sub-assembly. Table 6-1 shows the O-ring sizes.

The pressure sensor may be gently bent away from the pressure sensor manifold to access the sensor O-ring and confirm that the pressure ports are clear.

Replacing the Electronic Circuit Board

1. Verify that the circuit board is green for assembly into a direct action unit, or red for assembly into a reverse action unit.
2. Ensure that the three O-rings are in the proper position. The small O-ring is positioned in the beveled O-ring gland of the module subassembly. The two sensor O-rings are each positioned on the shoulders of the sensor. They should be lightly lubricated with silicone grease.
3. Ensure that the pressure sensor is correctly positioned against the manifold. The pressure sensor should be centered and in contact with the manifold, as shown in figure 6-5.
4. Position the circuit board on the module subassembly. Ensure that the circuit board mounting holes match those on the module subassembly. Place the three long screws in the mounting holes adjacent to the pressure sensor.
5. Place the two short screws in the remaining mounting holes. Tighten the three long screws first, then tighten the remaining two screws.

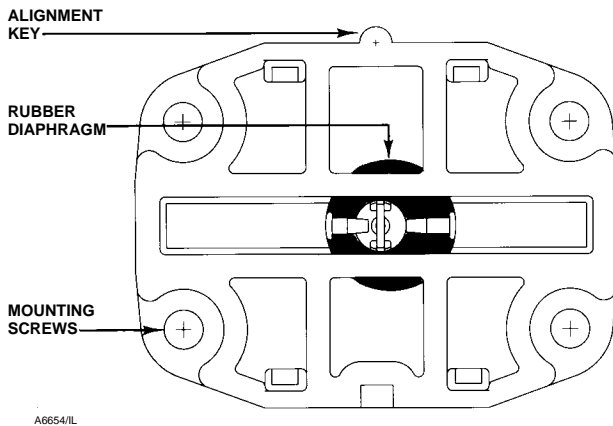

Figure 6-6. Pilot/Actuator Assembly (Bottom View)

Pilot/Actuator Assembly

WARNING

Refer to the Maintenance **WARNINGS** at the beginning of this section.

The pilot/actuator assembly is located at the bottom of the module final assembly, as shown in figure 6-1. It is a unitized assembly consisting of the coil, magnet, and spring of the actuator, and the deflector and nozzles of the pilot stage. Two O-rings are part of the pilot/actuator assembly. Table 6-1 shows the O-ring sizes. They are located in the beveled O-ring glands of the module subassembly, adjacent to the nozzles. The pilot/actuator assembly is held in place by four mounting screws.

Action

A blue rubber diaphragm under the deflector bar and nozzle area identifies the direct action pilot/actuator assembly. A red diaphragm under the nozzle area identifies the reverse action pilot/actuator assembly. Figure 6-6 shows the bottom view of the pilot/actuator assembly.

Removing the Pilot/Actuator Assembly

To remove the pilot/actuator assembly, disengage the four mounting screws, and gently pull the assembly out of the module subassembly. To aid removal, the pilot/actuator framework may be gently gripped with a pair of pliers.

CAUTION

Do not attempt to remove the pilot/actuator assembly by gripping or pulling on the deflector or nozzles. Doing so could alter the alignment or disable the deflector/nozzle mechanism.

Inspect the assembly for a buildup of foreign material. The nozzle passageways should be clear, and the deflector should be clean. The deflector can be cleaned by spraying it with contact cleaner. Clean the nozzles by gently inserting a wire with a maximum diameter of 0.38 mm (0.015 inches).

- Insert the wire into each nozzle **separately** from the outside as shown in figure 6-7.
- **Do not** try to put the wire through both nozzles simultaneously.
- **Do not** push the wire on the deflector bar.

CAUTION

Do not apply force to the deflector bar while cleaning the nozzles. Doing so could alter the alignment or disable the deflector mechanism.

CAUTION

Do not use chlorinated solvents for cleaning the pilot/actuator assembly. The chlorinated solvents will deteriorate the rubber diaphragm

Replacing the Pilot/Actuator Assembly

1. Verify that the rubber diaphragm under the nozzle area is blue for pilot/actuators inserted into a direct action unit, or red for pilot/actuators inserted into a reverse action unit.
2. Inspect the pilot/actuator assembly cavity in the module final assembly to ensure that it is clean.
3. Lightly lubricate the two O-rings with silicone grease, and place them in the beveled O-ring glands. O-rings between the pilot/actuator assembly and the module should be installed justified to the lower portion of the O-ring gland. When properly positioned, the air passageway should be visible through the O-ring inside diameter.

3311 Transducers

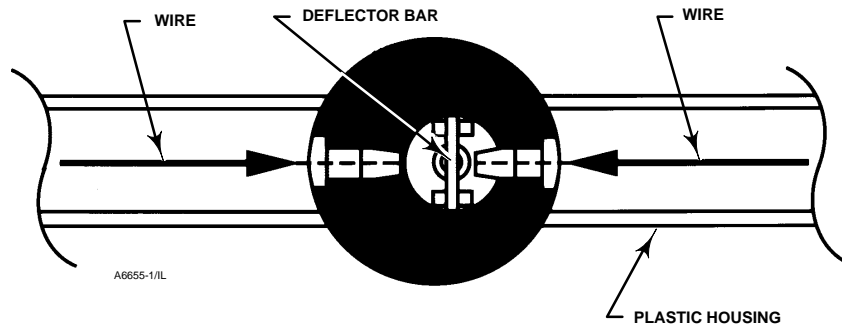

Figure 6-7. Cleaning the Nozzles

4. Prepare to insert the assembly by aligning the key on the pilot/actuator assembly with the key slot in the module subassembly.

5. Insert the assembly into the module subassembly, and engage the four mounting screws.

Module Subassembly



Refer to the Maintenance WARNING at the beginning of this section.

The module subassembly, shown in figure 6-1, consists of the module final assembly with both the electronic circuit board and pilot/actuator assembly removed. The module subassembly contains the porting and valving for the booster stage.

Note

The module subassembly is aligned at the factory and should not be further disassembled. Disassembling the module subassembly may result in performance outside specifications.

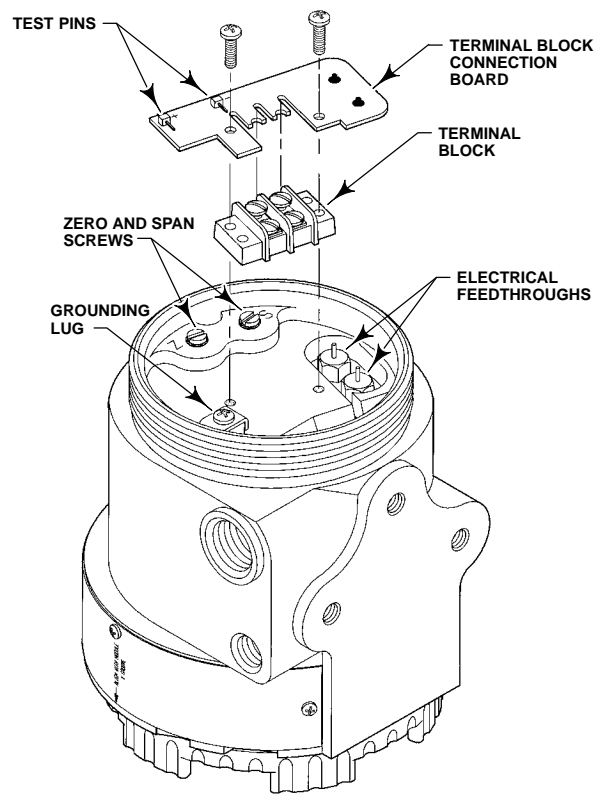

Figure 6-8. Terminal Compartment Exploded View

Terminal Compartment



Refer to the Maintenance WARNING at the beginning of this section.

The terminal compartment contains the terminal block, terminal block connection board, span and zero screws, electrical feedthroughs, and internal grounding lug, as shown in figure 6-8. The terminal block connection board is attached to the terminal block and to the electrical feedthroughs.

Separate test points are provided that have a 10-ohm resistor in series with the signal negative (-) terminal. The test points allow the input current to be determined with a voltmeter without disconnecting a signal lead. A 4 to 20 mA span produces a 40 to 200 mV DC voltage drop across the 10-ohm resistor. The test points can accommodate different connections, including alligator clips and E-Z hooks.

The terminal block and terminal block connection board can be removed by disengaging the two terminal block mounting screws. Lubricate the terminal compartment cover threads with anti-seizing paste or a low temperature lubricant. See table 6-1 for the size of the terminal compartment cover O-ring.

Exhaust and Stroke Port Screens



Refer to the Maintenance WARNING at the beginning of this section.

Two identical screens, the exhaust port screen and the stroke port screen, allow air to vent to the outside environment. The exhaust port screen is located behind the nameplate. Removing the two nameplate screws and rotating the nameplate to the side allows access to the exhaust port screen. Figure 7-3 shows an exploded parts view.

The stroke port screen is located at the center of the module cover. Removing the module final assembly from the housing and then from the module cover allows access to the stroke port screen. Removing the Module Final Assembly earlier in this section describes this procedure. Figure 7-3 shows an exploded parts view.

Section 7 Parts List

Whenever corresponding with your Emerson Process Management sales office about this equipment, always mention the transducer serial number. When ordering replacement parts, refer to the 11-character part number of each required part. Table 7-1 shows the key numbers for all replaceable parts.

instrument. Use of components not supplied by Emerson Process Management will void your warranty, might adversely affect the performance of the instrument, and could give rise to personal injury and property damage.

Note

Neither Emerson, Emerson Process Management, nor any of their affiliated entities assumes responsibility for the selection, use and maintenance of any product. Responsibility for the selection, use and maintenance of any product remains with the purchaser and end-user.



WARNING

Use only genuine Fisher replacement parts. Components that are not supplied by Emerson Process Management should not, under any circumstances, be used in any Fisher

Table 7-1. Parts List

KEY NO.	DESCRIPTION	PART NUMBER	SPARES CATEGORY ⁽⁶⁾
*	Module, standard – Final Assembly ⁽¹⁾		
	Standard Performance		
	Direct Action 4–20 mA	13B8788X012	B
	Direct Action 10–50 mA	14B5026X012	B
	Reverse Action 4–20 mA	13B8789X012	B
	Multirange Performance		
	Direct Action 4–20 mA	13B8790X012	B
	Direct Action 10–50 mA	18B5801X012	B
	Reverse Action 4–20 mA	13B8791X012	B
	Module, ATEX/IECEX Ex d and Dust – Final Assembly ⁽¹⁾		
	Standard Performance		
	Direct Action 4–20 mA	GE18543X012	B
	Direct Action 10–50 mA	GE18544X012	B
	Reverse Action 4–20 mA	GE18545X012	B
	Multirange Performance		
Direct Action 4–20 mA	GE18546X012	B	
Direct Action 10–50 mA	GE18547X012	B	
Reverse Action 4–20 mA	GE18548X012	B	
9*	Module Subassembly ^(1,2)		
	Standard Performance (Direct or Reverse Action)	13B8792X012	B
	ATEX/IECEX Ex d and Dust (Direct or Reverse Action)	GE18620X012	B
12*	Pilot/Actuator Assembly ⁽²⁾		
	Direct Action	13B8793X012	B
	Reverse Action	13B8794X012	B
8*	Circuit Board Assembly ⁽²⁾		
	Standard Performance		
	Direct Action	13B8795X012	B
	Reverse Action	13B8796X012	B
	Direct Action 10–50 mA	18B5803X012	B
3*	Housing ^(3,4)		
	Standard	18B5804X022	C
	ATEX/IECEX Ex d and Dust	18B5805X022	C
15*	Module Cover		
	Single Stroke Port	18B5806X012	C
	Multiple Ports	18B5807X012	C
	Threaded Stroke Port	18B5808X012	C
1*	Terminal Compartment Cover	18B5809X012	C
5*	Terminal Block Kit ⁽⁵⁾	13B8801X012	B

*Recommended spare parts

3311 Transducers

Table 7-1. Parts List Cross Reference (continued)

KEY NO.	DESCRIPTION	PART NUMBER	SPARES CATEGORY ⁽⁶⁾
16*	Screens (12/pkg)	13B8802X012	B
10*	O-Rings		
	Module (5/kit) ⁽⁷⁾	13B8803X012	B
	Module (5/kit, ATEX/IECEX Ex d and Dust) ⁽⁷⁾	GE18622X012	B
11*	Pilot/Actuator (5/kit) ⁽⁷⁾	13B8804X012	B
7*	Circuit Board (5/kit) ⁽⁷⁾	13B8805X012	B
2*, 21*, & 23*	Cover (12 O-rings, 12 slip rings) ⁽⁷⁾	13B8806X012	B
	Filter-Regulator (10/kit) ^(7,8)	18B5815X022	B
	Screws		
13*	Pilot/Actuator (3/kit) ⁽⁷⁾	13B8807X012	C
6*	Circuit Board (3/kit) ⁽⁷⁾	13B8808X012	C
14*	Nameplate (3/kit) ⁽⁷⁾	13B8809X012	C
18*	Retaining Clips (3/kit) ⁽⁷⁾	13B8810X012	C
22*	Module Cap (5/pkg) ⁽⁷⁾	18B5810X012	B
	Filter-Regulator Direct Mounting Kit ^(9,10) SST Bolts	18B5811X022	B
	Filter-Regulator with Direct Mounting Kit ^(9,10) SST Bolts		C
	Universal Mounting Bracket Epoxy Painted Carbon Steel, Carbon Steel Nuts/Bolts Epoxy Painted Carbon steel, SST Nuts/Bolts 316 SST, SST Nuts/Bolts for use with SST Housing 316 SST, SST Nuts/Bolts for use with Aluminum Housing		C C C C
	Supply Gauge (see figure 7-1) 0-60 psi/0-400 kPa/0-4 bar SST 0-60 psi/0-400 kPa/0-4 bar	19B3088X012 19B3091X012	B B
*	Output Gauge (see figure 7-2) 0-30 psi/0-200 kPa/0-2 bar 0-60 psi/0-400 kPa/0-4 bar SST 0-60 psi/0-400 kPa/0-4 bar	19B3086X012 19B3089X012 19B3092X012	B B B
	Tire Valve Adapter Assembly	1H4470X0012	

1. For units with approvals other than ATEX/IECEX Ex d and Dust, use standard module.
 2. Includes O-rings.
 3. Includes housing, span and zero screws, electrical feedthroughs, and grounding lug.
 4. For units with approvals other than ATEX/IECEX Ex d and Dust, use standard housing.
 5. Includes terminal block, connection board, and screws.
 6. **Spare Categories**
 Category A – Recommend 1 spare part per 25 transducers
 Category B – Recommend 1 spare part per 50 transducers
 Category C – None normally required.
 7. #/kit indicates number of transducers that may be serviced.
 8. Contains O-rings for both housing styles.
 9. Filter-Regulator Direct Mounting Kit includes O-ring.
 10. Extra O-ring and spacer included for both housing styles.

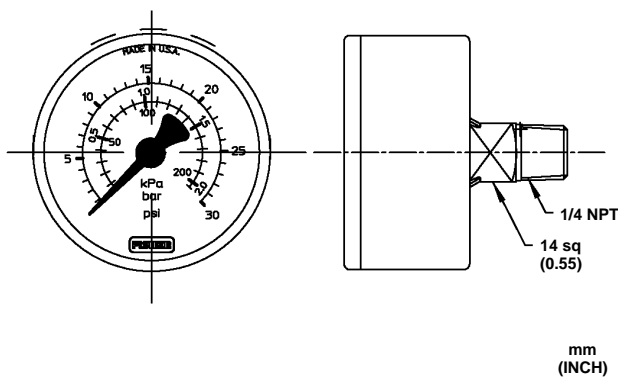

Figure 7-1. Supply Gauge

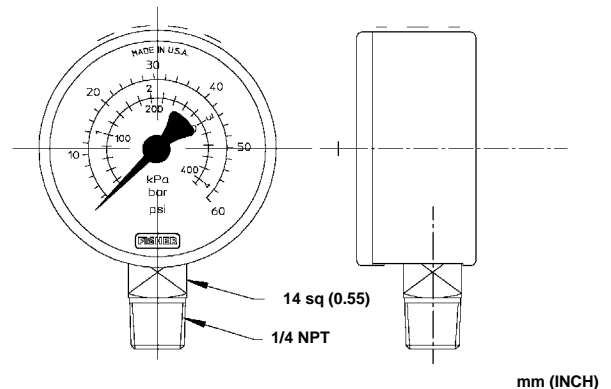
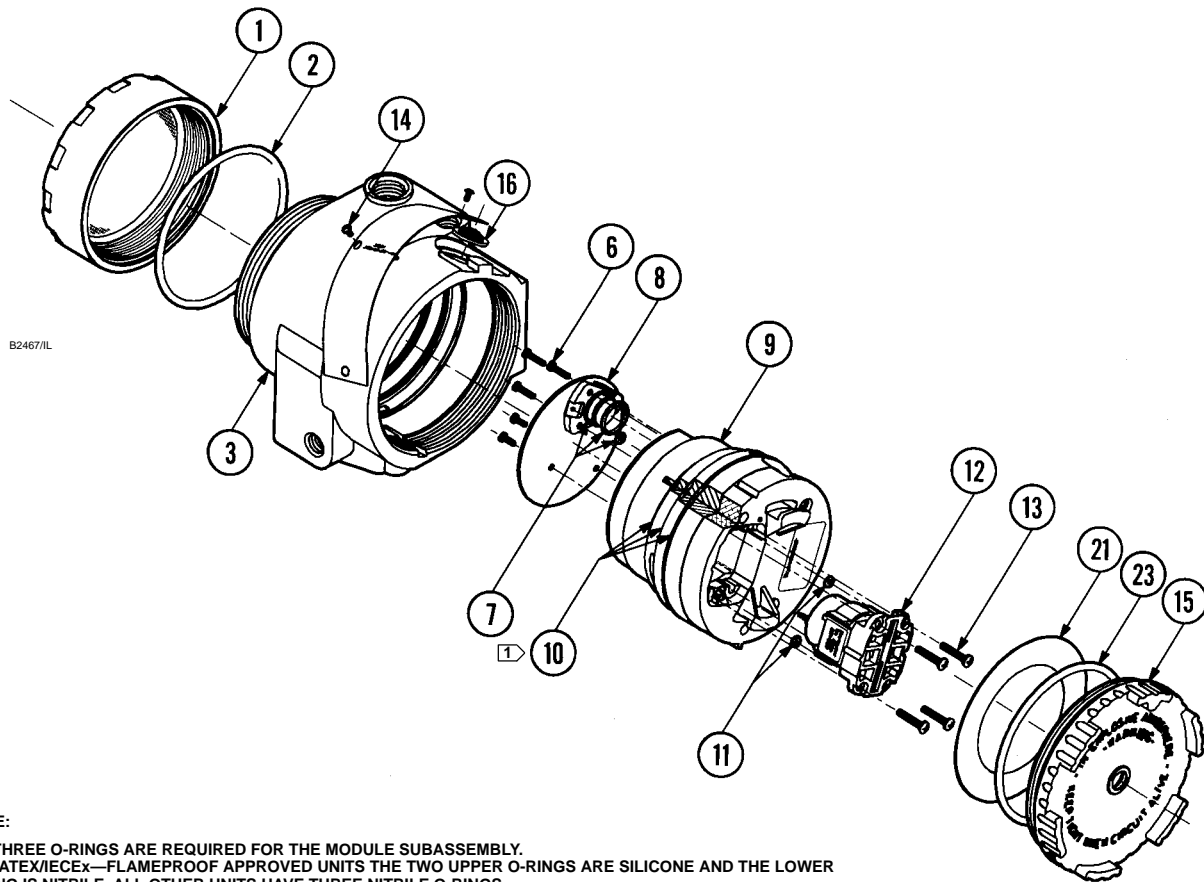

Figure 7-2. Output Gauge



NOTE:

① THREE O-RINGS ARE REQUIRED FOR THE MODULE SUBASSEMBLY. FOR ATEX/IECEx—FLAMEPROOF APPROVED UNITS THE TWO UPPER O-RINGS ARE SILICONE AND THE LOWER O-RING IS NITRILE. ALL OTHER UNITS HAVE THREE NITRILE O-RINGS.

Figure 7-3. Exploded Parts Drawing (also see table 7-2)

Table 7-2. Key Number Quick Reference

KEY NO.	DESCRIPTION
1	Terminal Compartment Cover
2	Terminal Compartment Cover O-ring
3	Housing
5	Terminal Block Kit
6	Electronic Circuit Board Screws
7	Electronic Circuit Board O-rings
8	Electronic Circuit Board Assembly
9	Module Subassembly
10	Module O-rings
11	Pilot/Actuator Assembly O-rings
12	Pilot/Actuator Assembly
13	Pilot Actuator Assembly Screws
14	Nameplate Screws
15	Module Cover
16	Exhaust/Stroke Port Screen
18	Retaining Clip
21	Slip Ring
23	Module Cover O-ring

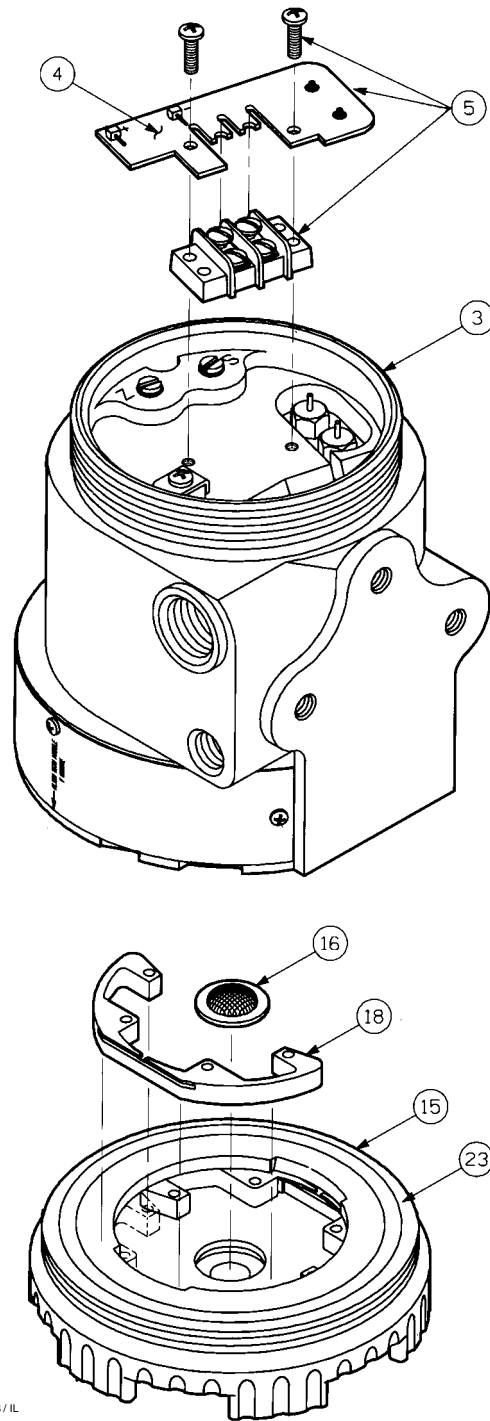

B2468 / IL

Figure 7-3. Exploded Parts Drawing (also see table 7-2) (continued)

Section 8 Loop Schematics/Nameplates

This section includes loop schematics required for wiring of intrinsically safe installations. It also contains the approvals nameplates. If you have any questions, contact your Emerson Process Management sales office.

CSA INTRINSIC SAFETY APPROVALS
846 AND 3311 CIRCUIT CONNECTION WITH
INTRINSIC SAFETY BARRIERS

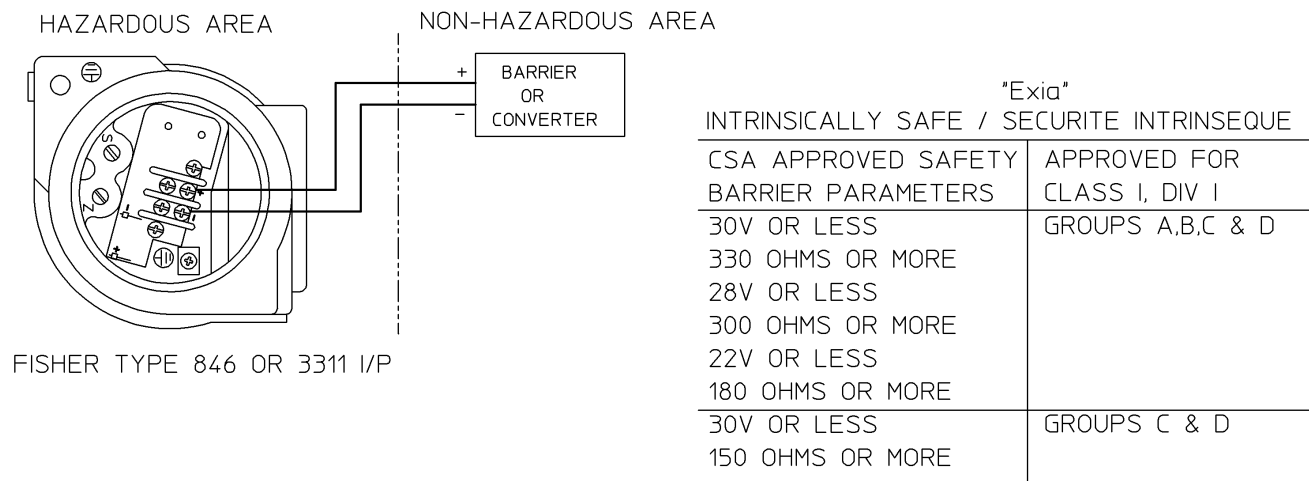

13B8779-C/ doc

Figure 8-1. CSA Loop Schematic

FISHER CONTROLS INTL LLC
MARSHALLTOWN, IOWA, USA
MFG LOCATION: 088

CURRENT TO PRESSURE TRANSDUCER (I/P)

MODEL

SN YEAR

INPUT

OUTPUT

MAX VOLTAGE: 12 VDC MAX CURRENT: 100 mADC IP66
MAX SUPPLY PRESSURE: 35 PSI

MAY BE PROTECTED BY ONE OR MORE OF THE FOLLOWING U.S. PATENT NUMBERS: 4,665,938; 4,760,859; 4,777,826; 4,901,756
OTHER FOREIGN PATENTS ISSUED AND PENDING.
FACTORY SEALED, NEMA 4X, CSA 4X

FM

XP: CL I DIV 1 GP BCD
DIP: CL II, III DIV 1 GP EFG
NI: CL I DIV 2 GP ABCD
IS: CL I,II,III, DIV 1 GP ABCDEFG
PER DWG 13B8780
T5 (Tamb; -40°C TO 60°C)

CSA

Ex ia INTRINSICALLY SAFE
CL I DIV 1 GP ABCD
T4 PER DWG 13B8779

CL I DIV 2 GP ABCD
CL I DIV 1 GP CD, CL II, III GP EFG
AMB TEMP: -40°C TO 80°C

100mA MAX PRODUCES 12 VDC MAX ACROSS TERMINALS
WARNING: SUBSTITUTION OF COMPONENTS MAY IMPAIR INTRINSIC SAFETY

ALIGN WITH MODULE V GROOVE

GE18108

Figure 8-2. CSA and FM Approvals Nameplate

3311 Transducers

FM ENTITY CONCEPT APPROVALS

THE FISHER TYPE 846 AND 3311 CURRENT TO PRESSURE (I/P) TRANSDUCER ARE FM APPROVED AS INTRINSICALLY SAFE FOR USE IN CLASS I, II AND III, DIVISION I, GROUPS A,B,C,D,E,F AND G HAZARDOUS LOCATIONS WHEN CONNECTED IN ACCORDANCE WITH THIS DOCUMENT. THE TYPE 846 AND 3311 ARE ALSO FM APPROVED AS NONINCENDIVE FOR CLASS I, DIVISION 2, GROUPS A,B,C AND D HAZARDOUS LOCATIONS.

TO MAINTAIN THE INTRINSIC SAFETY OF THE 846 OR 3311. IT MUST BE CONNECTED TO AN FM APPROVED BARRIER THAT SATISFIES THE FOLLOWING CONDITIONS:

CLASS I, II AND III, DIV I GROUPS A,B,C,D,E,F AND G

APPARATUS PARAMETER	BARRIER PARAMETER
$V_{MAX} = 40 \text{ Vdc}$	V_{OC} MUST BE LESS THAN OR EQUAL TO 40 Vdc
$I_{MAX} = 185 \text{ mA}$	I_{SC} MUST BE LESS THAN OR EQUAL TO 185 mA
$L_I = 20 \text{ uH}$	L_A MUST BE GREATER THAN 20 MICROHENRIES
$C_I = 0.016 \text{ uF}$	C_A MUST BE GREATER THAN 0.016 MICROFARADS

- WHERE: V_{MAX} = MAXIMUM 846 OR 3311 INPUT VOLTAGE
 I_{MAX} = MAXIMUM 846 OR 3311 INPUT CURRENT
 C_I = TOTAL UNPROTECTED INTERNAL CAPACITANCE OF THE 846 OR 3311
 L_I = TOTAL UNPROTECTED INTERNAL INDUCTANCE OF THE 846 OR 3311
 V_{OC} = OPEN CIRCUIT VOLTAGE OF THE BARRIER
 I_{SC} = SHORT CIRCUIT CURRENT OF THE BARRIER
 C_A = ACCEPTABLE CONNECTED CAPACITANCE OF THE BARRIER
 L_A = ACCEPTABLE CONNECTED INDUCTANCE OF THE BARRIER

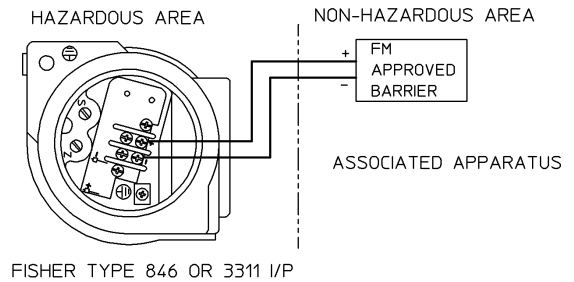







Figure 8-3. FM Loop Schematic

	FISHER CONTROLS INTL LLC MARSHALLTOWN, IOWA, USA MFG LOCATION: 077		○ ALIGN WITH MODULE V GROOVE ↓	○ MAY BE PROTECTED BY ONE OR MORE OF THE FOLLOWING U.S. PATENT NUMBERS: 4,481,967, 4,534,376, 4,638,830, 4,653,523, 4,665,938, 4,760,859, 4,777,826, 4,901,756, DES. 316,975. MEXICO PATENTADO NO. 157,704. OTHER FOREIGN PATENTS ISSUED AND PENDING. Amb Temp: -40°C to 80°C IP66 LCIE 03 ATEX 6298X (E) II 1 G & D EEx ia IIC T4(Tamb=80°C) T5(Tamb=40°C) Ui = 40VDC li = 200mA Pi = 1.0W Ci = 8nF Li = 20uH MAX. ENCLOSURE SURFACE TEMP T90°C(Tamb=80°C)	○ GE03594
	CURRENT TO PRESSURE TRANSDUCER (I/P)				
	MODEL	<input type="text"/>			
	SN	<input type="text"/> YEAR <input type="text"/>			
	INPUT	<input type="text"/>			
OUTPUT	<input type="text"/>				
MAX VOLTAGE: 12 VDC MAX CURRENT: 100 mADC IP66 MAX SUPPLY PRESSURE: 35 PSI AMB TEMP: -40°C TO 80°C		○  1180 100mA MAX PRODUCES 12 VDC MAX ACROSS TERMINALS			

ATEX INTRINSIC SAFETY, DUST

	FISHER CONTROLS INTL LLC MARSHALLTOWN, IOWA, USA MFG LOCATION: 077		○ ALIGN WITH MODULE V GROOVE ↓	○ MAY BE PROTECTED BY ONE OR MORE OF THE FOLLOWING U.S. PATENT NUMBERS: 4,481,967, 4,534,376, 4,638,830, 4,653,523, 4,665,938, 4,760,859, 4,777,826, 4,901,756, DES. 316,975. MEXICO PATENTADO NO. 157,704. OTHER FOREIGN PATENTS ISSUED AND PENDING. Amb Temp: -40°C to 85°C IP66 LCIE 03 ATEX 6299 (E) II 3 G & D EEx nL IIC T5(Tamb=85°C) T6(Tamb=74°C)	○ GE03712
	CURRENT TO PRESSURE TRANSDUCER (I/P)				
	MODEL	<input type="text"/>			
	SN	<input type="text"/> YEAR <input type="text"/>			
	INPUT	<input type="text"/>			
OUTPUT	<input type="text"/>				
MAX VOLTAGE: 12 VDC MAX CURRENT: 100 mADC IP66 MAX SUPPLY PRESSURE: 35 PSI AMB TEMP: -40°C TO 80°C		○  1180 100mA MAX PRODUCES 12 VDC MAX ACROSS TERMINALS			

ATEX TYPE n, DUST

	FISHER CONTROLS INTL LLC MARSHALLTOWN, IOWA, USA MFG LOCATION: 077		○ ALIGN WITH MODULE V GROOVE ↓	○ MAY BE PROTECTED BY ONE OR MORE OF THE FOLLOWING U.S. PATENT NUMBERS: 4,481,967, 4,534,376, 4,638,830, 4,653,523, 4,665,938, 4,760,859, 4,777,826, 4,901,756, DES. 316,975. MEXICO PATENTADO NO. 157,704. OTHER FOREIGN PATENTS ISSUED AND PENDING. Baseefa05ATEX0130X (E) II 2 G & D Ex d IIB T5(Tamb ≤ 80°C) T6(Tamb ≤ 65°C) WARNING – DO NOT OPEN WHEN AN EXPLOSIVE ATMOSPHERE IS PRESENT MAX. ENCLOSURE SURFACE TEMP T90°C(Tamb ≤ 80°C) WHEN OPERATING ABOVE 70°C – USE SUITABLE CABLING/WIRING	○ GE06215
	CURRENT TO PRESSURE TRANSDUCER (I/P)				
	MODEL	<input type="text"/>			
	SN	<input type="text"/> YEAR <input type="text"/>			
	INPUT	<input type="text"/>			
OUTPUT	<input type="text"/>				
MAX VOLTAGE: 12 VDC MAX CURRENT: 100 mADC IP66 MAX SUPPLY PRESSURE: 35 PSI AMB TEMP: -40°C TO 80°C		○  1180 100mA MAX PRODUCES 12 VDC MAX ACROSS TERMINALS			

ATEX FLAMEPROOF, DUST

Figure 8-4. ATEX Approvals Nameplates

3311 Transducers

FISHER FISHER CONTROLS INTL LLC
MARSHALLTOWN, IOWA, USA
MFG LOCATION:

CURRENT TO PRESSURE TRANSDUCER (I/P)

MODEL

SN YEAR

INPUT

OUTPUT

MAX VOLTAGE: 12 VDC MAX CURRENT: 100 mA DC IP66
MAX SUPPLY PRESSURE: 35 PSI AMB TEMP: -40°C TO 80°C

MAY BE PROTECTED BY ONE OR MORE OF THE FOLLOWING U.S. PATENT NUMBERS: 4,481,967, 4,534,376, 4,638,830, 4,653,523, 4,665,938, 4,760,859, 4,777,826, 4,901,756, DES. 316,975, MEXICO PATENTADO NO. 157,704, OTHER FOREIGN PATENTS ISSUED AND PENDING.

CERT NO. IECEx BAS 04.0023X

Ex ia IIC T4(-40°C ≤ Ta ≤ +80°C) OR Ex ia IIC T5(-40°C ≤ Ta ≤ +40°C)
DIP A20 T_A 90°C IP66 DIP A20 T_A 50°C IP66
U_i = 40V I_i = 200mA P_i = 1.0W C_i = 8nF L_i = 20uH

DIP A20 T_A 90°C IP66(-40°C ≤ Ta ≤ +80°C)

Ex nL IIC T5(-40°C ≤ Ta ≤ +80°C) OR Ex nL IIC T6(-40°C ≤ Ta ≤ +75°C)
DIP A22 T_A 90°C IP66 DIP A22 T_A 85°C IP66

THIS EQUIPMENT SHALL BE USED ONLY FOR THE PROTECTION CONCEPT AS MARKED WITH AN "X" IN THE APPROPRIATE BOX

ALIGN WITH MODULE V GROOVE

INTRINSIC SAFETY, DUST APPROVAL INFORMATION

DUST APPROVAL INFORMATION

TYPE n, DUST APPROVAL INFORMATION

IECEx INTRINSIC SAFETY, DUST, TYPE n

FISHER FISHER CONTROLS INTL LLC
MARSHALLTOWN, IOWA, USA
MFG LOCATION:

CURRENT TO PRESSURE TRANSDUCER (I/P)

MODEL

SN YEAR

INPUT

OUTPUT

MAX VOLTAGE: 12 VDC MAX CURRENT: 100 mA DC IP66
MAX SUPPLY PRESSURE: 35 PSI AMB TEMP: -40°C TO 80°C

MAY BE PROTECTED BY ONE OR MORE OF THE FOLLOWING U.S. PATENT NUMBERS: 4,481,967, 4,534,376, 4,638,830, 4,653,523, 4,665,938, 4,760,859, 4,777,826, 4,901,756, DES. 316,975, MEXICO PATENTADO NO. 157,704, OTHER FOREIGN PATENTS ISSUED AND PENDING.

CERT NO. IECEx BAS 05.0049X

Ex d IIB T5(Tamb ≤ 80°C) T6(Tamb ≤ 65°C)

WARNING - DO NOT OPEN WHEN AN EXPLOSIVE ATMOSPHERE IS PRESENT

DIP A21 T_A 90°C IP66

WHEN OPERATING ABOVE 70°C - USE SUITABLE CABLING/WIRING

100mA MAX PRODUCES 12 VDC MAX ACROSS TERMINALS

ALIGN WITH MODULE V GROOVE

IECEx FLAMEPROOF, DUST

Figure 8-5. IECEx Approvals Nameplates

3311 Transducers

Fisher is a mark owned by Fisher Controls International LLC, a member of the Emerson Process Management business division of Emerson Electric Co. Emerson, Emerson Process Management, and the Emerson logo are trademarks and service marks of Emerson Electric Co. HART is a mark owned by the HART Communication Foundation. All other marks are the property of their respective owners. This product may be covered by one or more of the following patents (4,481,967; 4,534,376; 4,638,830; 4,653,523; 4,665,938; 4,760,859; 4,777,826; 4,901,756) or under pending patent applications.

The contents of this publication are presented for informational purposes only, and while every effort has been made to ensure their accuracy, they are not to be construed as warranties or guarantees, express or implied, regarding the products or services described herein or their use or applicability. We reserve the right to modify or improve the designs or specifications of such products at any time without notice.

Neither Emerson, Emerson Process Management, nor any of their affiliated entities assumes responsibility for the selection, use and maintenance of any product. Responsibility for the selection, use and maintenance of any product remains with the purchaser and end-user.

Emerson Process Management

Marshalltown, Iowa 50158 USA
Sorocaba, 18087 Brazil
Chatham, Kent ME4 4QZ UK
Dubai, United Arab Emirates
Singapore 128461 Singapore

www.Fisher.com