

Fisher® 667 Diaphragm Actuator Sizes 30-76 and 87

Contents

Introduction	1
Scope of Manual	1
Description	2
Specifications	3
Maximum Pressure Limitations	3
Installation	3
Mounting the Actuator on the Valve	4
Discussion of Bench Set	6
Spring Verification	6
Installing the Stem Connector Assembly	7
Deadband Measurement	9
Loading Connection	9
Maintenance	9
Actuator	10
Top-Mounted Handwheel Assembly (Adjustable Down Travel Stop)	12
Side-Mounted Handwheel Assembly for Size 34 through 60 Actuators	14
Side-Mounted Handwheel Assembly for Size 70, 76, and 87 Actuators	15
Casing-Mounted Travel Stops	17
Parts Kits	19
Side-Mounted Handwheels Retrofit Kits	19
Top-Mounted Handwheel Retrofit Kits	19
Actuator Repair Kits	19
Parts List	19
Actuator Assembly	19
Top-Mounted Handwheel	21
Side-Mounted Handwheel (30-60)	23
Side-Mounted Handwheel (70, 76, and 87)	23
Casing Mounted Travel Stops	24



Figure 1. Fisher® 667 or 667-4 Actuator Mounted on easy-e® Valve

through 76 and size 87. The 667-4 actuator in sizes 70 and 87 is also covered. Refer to separate instruction manuals for information about the valve positioner and other accessories used with these actuators.

Do not install, operate, or maintain a 667 actuator (see figure 1) without first being fully trained and qualified in valve, actuator, and accessory installation, operation, and maintenance, and carefully reading and understanding the contents of this manual. If you have any questions about these instructions, contact your Emerson Process Management sales office before proceeding.

Introduction

Scope of Manual

This instruction manual provides information on installation, adjustment, maintenance, and parts ordering for the Fisher® 667 actuator in sizes 30



667 Size 30-76 and 87 Actuators

October 2008

Table 1. Specifications

SPECIFICATION ⁽¹⁾		ACTUATOR SIZE										
		30	34	40	45	46	50	60	70 ⁽¹⁾	76	87 ⁽¹⁾	
Nominal Effective Area	Sq cm	297	445	445	667	1006	677	1006	1419	1006	1419	
	Sq Inch	46	69	69	105	156	105	156	220	156	220	
Yoke Boss Diameter	mm	54	54	71	71	71	90	90	90	90	125	
	Inch	2-1/8	2-1/8	2-13/16	2-13/16	2-13/16	3-9/16	3-9/16	3-9/16	3-9/16	5	
Acceptable Valve Stem Diameter	mm	9.5	9.5	12.7	12.7	12.7	19.1	19.1	19.1	19.1	25.4	
	Inch	3/8	3/8	1/2	1/2	1/2	3/4	3/4	3/4	3/4	1	
Maximum Allowable Output Thrust ⁽⁴⁾	N	10,230	10,230	12,010	25,131	33,582	25,131	30,246	39,142	30,246	39,142	
	LB	2300	2300	2700	5650	7550	5650	6800	8800	6800	8800	
Maximum Travel ⁽²⁾	Standard	mm	19	29	38	51	51	51	51	76 ⁽³⁾	51	76 ⁽³⁾
		Inch	0.75	1.125	1.5	2	2	2	2	3 ⁽³⁾	2	3 ⁽³⁾
	Top-Loaded	mm	---	19	---	19	---	---	29	---	29	76
		Inch	---	0.75	---	0.75	---	---	1.125	---	1.125	3
Maximum Casing Pressure for Actuator Sizing ^(4,6)	Bar	3.8	4.8	4.8	4.5	3.5	4.5	3.5	3.4	3.4	3.4	
	Psig	55	70	70	65	55	65	55	50	50	50	
Maximum Excess Diaphragm Pressure ^(4,5)	Bar	3.9	1.4	1.4	0.7	0.7	0.7	0.7	0.7	0.7	0.7	
	Psig	55	20	20	10	10	10	10	10	10	10	
Maximum Diaphragm Casing Pressure ^(4,6,7)	Bar	7.6	6.2	6.2	5.2	4.5	5.2	4.5	4.1	4.1	4.1	
	Psig	110	90	90	75	65	75	65	60	60	60	
Approximate Weight	Kg	15	22	23	41	55	43	55	115	86	118	
	Pounds	34	48	50	90	121	94	122	254	190	260	
Material Temperature Capabilities	Nitrile Elastomers	-40 to 82°C (-40 to 180°F)										
	Silicone Elastomers	-54 to 149°C (-65 to 300°F)										

1. These values also apply to the 667-4 actuator construction.
 2. Actuator travel may be less than the value listed after connected to the valve.
 3. Maximum actuator travel for 667-4 is 102 mm (4 inches).
 4. See also the Specification portion of the introduction section.
 5. Additional pressure may be added when the actuator is at full travel. If the Maximum Excess Diaphragm Pressure is exceeded, damage to the diaphragm or diaphragm casing might result. See the Maximum Pressure Limitation section.
 6. Maximum diaphragm casing pressure must not be exceeded and must not produce a force on the actuator stem greater than the maximum allowable actuator output thrust or the maximum allowable stem load. See the Maximum Pressure Limitation section.
 7. This maximum casing pressure is not to be used for normal operating pressure. Its purpose is to allow for typical regulator supply settings and/or relief valve tolerances.

Description

The 667 actuator (figure 1) and the 667-4 actuator are reverse-acting, spring-opposed diaphragm actuators. They provide automatic operation of control valves. The 667 actuator provides 76 mm (3 inches) maximum actuator travel. The 667-4 actuator provides 102 mm (4 inches) maximum actuator travel. Both actuators position the valve plug in response to varying pneumatic loading pressure on the diaphragm. Figure 2 shows the operation of these actuators.

A 667 or 667-4 actuator can be furnished with either

a top-mounted or a side-mounted handwheel assembly. A top-mounted handwheel assembly is normally used as an adjustable down travel stop. (A down travel stop limits actuator travel in the down direction [when the stem is traveling out of the actuator]. Travel in the up direction is when the stem is traveling into the actuator.) A side-mounted handwheel assembly is normally used as an auxiliary manual actuator. The side-mounted handwheel can also be used as an adjustable up or down travel stop. Casing-Mounted adjustable up or down travel stops are also available on this actuator.

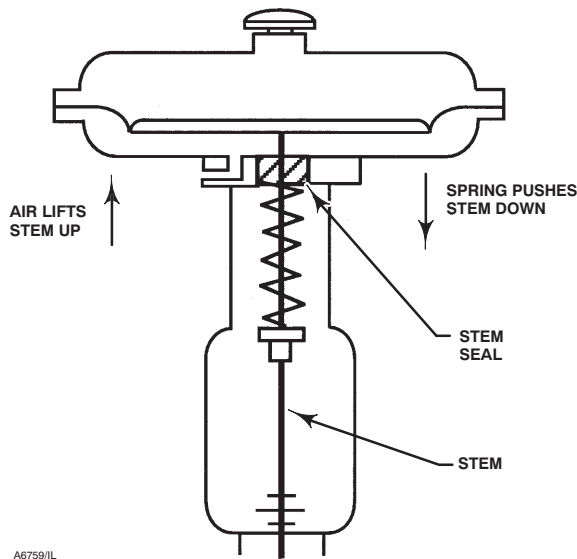

A6759/IL

Figure 2. Schematic of Fisher® 667 and 667-4 Actuators

Note

If repeated or daily manual operation is expected, the actuator should be equipped with a side-mounted handwheel rather than a casing-mounted travel stop or top-mounted handwheel. The side-mounted handwheel is designed for more frequent use as a manual operator.

Specifications

Refer to table 1 for Specifications of the 667 and 667-4 actuators. See the actuator nameplate for specific information for your actuator.

WARNING

To avoid personal injury or damage to equipment that may result in the malfunction of the control valve or loss of control of the process caused by excessive pressure, do not exceed the Maximum Pressures listed in table 1. Refer to the Maximum Pressure Limitations section below.

Maximum Pressure Limitations

The casing and diaphragm of 667 actuators are pressure operated. This air pressure provides energy to compress the spring, to stroke the actuator, and to seat the valve. The following explanations describe the maximum pressure limits for an actuator. Refer to the nameplate or table 1 for maximum values for your actuator.

- **Maximum Casing Pressure for Actuator Sizing:** This is the maximum pressure that can be applied at less than full travel of the actuator. If this stroking pressure is exceeded before the upper diaphragm plate contacts the travel stop, damage to the stem or other parts might result.

- **Maximum Excess Diaphragm Pressure:** Additional pressure may be added when the actuator is at full travel. If the Maximum Excess Diaphragm Pressure is exceeded, damage to the diaphragm or diaphragm casing might result.

Because the actuator has traveled its specified travel, and the diaphragm head is physically stopped from movement, the energy from any additional air pressure is transmitted to the diaphragm and diaphragm casings. The amount of air pressure that can be added once the actuator has traveled to the stops is limited by the resultant adverse effects that may occur. Exceeding this limiting factor could result in leakage or casing fatigue due to the deformation of the upper diaphragm casing.

- **Maximum Diaphragm Casing Pressure:** If the Maximum Diaphragm Casing Pressure is exceeded, damage to the diaphragm, diaphragm casing, or actuator might result.

Installation

WARNING

Always wear protective gloves, clothing, and eyewear when performing any installation operations. Check with your process or safety engineer for any other hazards that may be present from exposure to process media.

If installing into an existing application, also refer to the **WARNING** at the beginning of the Maintenance section in this instruction manual.

667 Size 30-76 and 87 Actuators

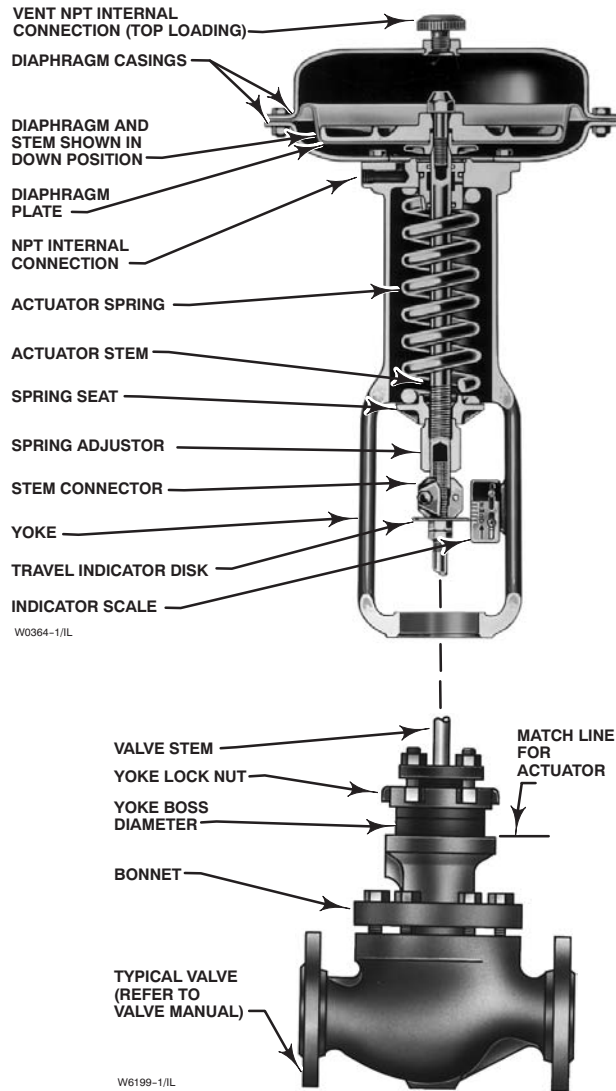

Figure 3. Actuator-Mounting Components for Size 30 through 70 Actuators

Key number locations are shown in figures 6, 7, and 8, unless otherwise noted. Also, refer to figure 3 for location of parts.

CAUTION

To avoid parts damage, do not use an operating pressure that exceeds the Maximum Diaphragm Casing Pressure (table 1) or produces a force on the actuator stem greater than the Maximum Allowable Output Thrust

(table 1) or the Maximum Allowable Valve Stem Load.

- **Valve/Actuator Assembly:** If the actuator and valve are shipped together as a control valve assembly, it has been adjusted at the factory, and may be installed in the pipeline. After installing the valve in the pipeline, refer to the Loading Connection procedures.

- **Actuator Mounting:** If the actuator is shipped separately or the actuator has been removed from the valve, it is necessary to mount the actuator on the valve before placing the valve in the pipeline. Refer to the following actuator mounting procedures before placing the valve in service. It is recommended that you perform the Bench Set Spring Adjustment procedures in this section to confirm that the actuator is adjusted correctly for the valve travel.

- **Positioner:** If a positioner is installed, or is to be installed on the actuator, refer to the positioner instruction manual for installation. During the adjustment procedures, it will be necessary to provide a temporary loading pressure to the actuator diaphragm.

- **Handwheel Cap:** If the handwheel cap (key 247, figures 9, 11, or 16) is not in place, install the cap by pushing it on by hand until it snaps into place.

Mounting the Actuator on the Valve

CAUTION

The 667 actuator spring load pushes the stem down out of the actuator yoke (see figure 2), and it can come in contact with the valve stem during actuator mounting.

If the valve stem is allowed to remain in the up position (towards the actuator) during actuator mounting, it can interfere with the actuator stem during mounting. It is possible to damage valve stem threads or bend the valve stem. Be sure the valve stem is pushed down (into the valve body), away from the actuator while mounting.

It may be necessary to apply a temporary loading pressure to the actuator to move the actuator stem away from the valve during installation.

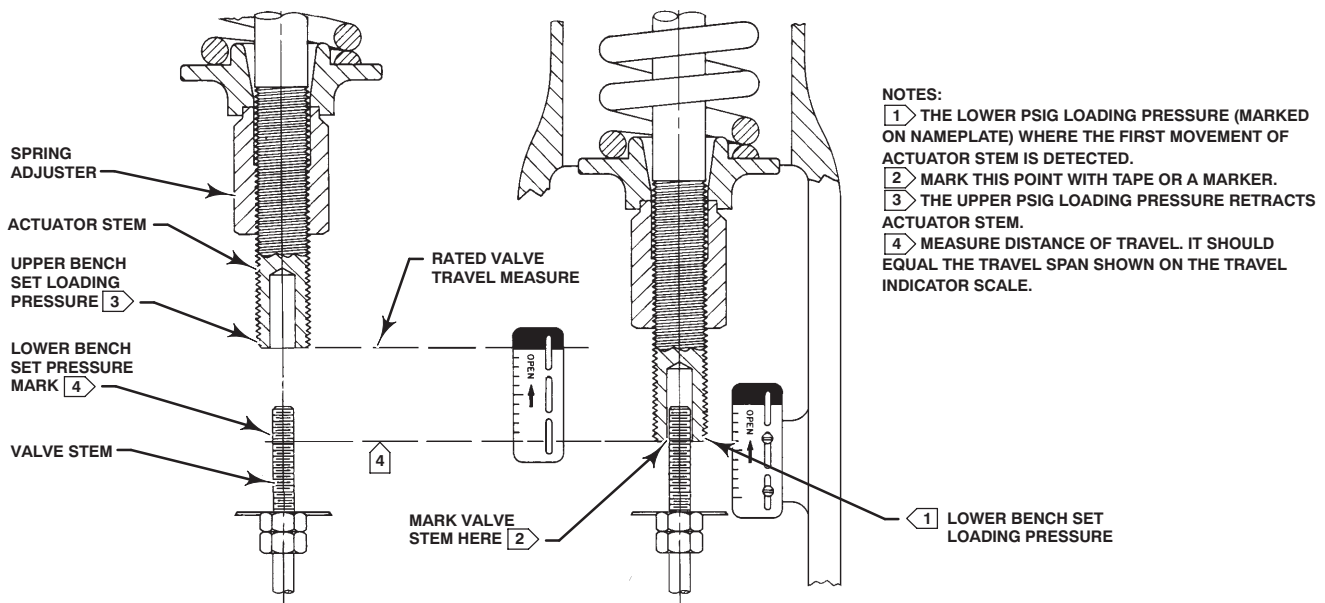

Figure 4. Bench Set Adjustment

If it is not possible to provide a temporary loading pressure, be very careful when lowering the actuator over the valve stem to prevent damage to valve stem and threads.

WARNING

When moving the actuator stem with loading pressure applied, exercise caution to keep hands and tools out of the actuator stem travel path. If the loading pressure is accidentally disconnected, personal injury and property damage may result if something is caught between the actuator stem and other control valve parts.

1. Provide a vise or some other method of supporting the valve and the weight of the actuator during assembly. For direct or reverse acting valves, push the valve stem down away from the actuator while mounting the actuator.
2. Screw the stem locknuts all the way onto the valve stem. With the concave side of the travel indicator disk (key 34) facing the valve, install the travel indicator disk on the valve stem. (Note: The travel indicator disk is not used with size 87 actuators.)

3. Lift or hoist the actuator onto the valve bonnet:

a. **For size 87 actuators:** Slowly lower the actuator down onto the valve while guiding the valve stem into the opening in the end of the actuator stem (see figure 4). Once the actuator is in place, insert the cap screws and tighten the hex nuts, securing the actuator to the bonnet.

b. **For all other size actuators:**

- Slowly lower the actuator down onto the valve. As the yoke passes over the end of the valve stem, place the yoke locknut over the valve stem. (Note: On small size actuators, it may be necessary to remove the indicator disk and re-install it while lowering the actuator onto the valve because the disk will not go through the actuator yoke opening).
- Continue to lower the actuator while guiding the valve stem into the opening in the end of the actuator stem until the actuator is in place (see figure 4).
- Screw the yoke locknut onto the valve bonnet and tighten the locknut.

4. Do not connect the actuator stem to the valve stem at this time. Whenever the actuator is installed on the valve, it is recommended that you perform the Bench Set Spring Adjustment procedures below, to verify that the actuator is still adjusted correctly.

667 Size 30-76 and 87 Actuators

Discussion of Bench Set

The bench set pressure range is used to adjust the initial compression of the actuator spring with the valve-actuator assembly “on the bench.” The correct initial compression ensures that the valve-actuator assembly will function properly when it is put into service and the proper actuator diaphragm operating pressure is applied.

The bench set range is established with the assumption that there is no packing friction. When attempting to adjust the spring in the field, it is very difficult to ensure that there is no friction being applied by “loose” packing.

Accurate adjustment to the bench set range can be made during the actuator mounting process by making the adjustment before the actuator is connected to the valve (see the Bench Set Spring Adjustment Procedure).

If you are attempting to adjust the bench set range after the actuator is connected to the valve and the packing tightened, you must take friction into account. Make the spring adjustment so full actuator travel occurs at the bench set range (a) plus the friction force divided by the effective diaphragm area with increasing diaphragm pressure or (b) minus the friction force divided by the effective diaphragm area with decreasing diaphragm pressure.

For an assembled valve-actuator assembly, the valve friction may be determined by following the procedure described below:

1. Install a pressure gauge in the actuator loading pressure line that connects to the actuator diaphragm casing.

Note

Steps 2 and 4 require that you read and record the pressure shown on the pressure gauge.

2. Increase the actuator diaphragm pressure and read the diaphragm pressure as the actuator reaches its mid-travel position.
3. Increase the actuator diaphragm pressure until the actuator is at a travel position greater than its mid-travel position.
4. Decrease the actuator diaphragm pressure and read the diaphragm pressure as the actuator reaches its mid-travel position.

The difference between the two diaphragm pressure readings is the change in the diaphragm pressure

required to overcome the friction forces in the two directions of travel.

5. Calculate the actual friction force:

$$\text{Friction Force, = 0.5} \left(\begin{array}{c} \text{Difference} \\ \text{in pressure} \\ \text{readings, psig} \end{array} \right) \times \left(\begin{array}{c} \text{Effective} \\ \text{diaphragm area,} \\ \text{inches}^2 \end{array} \right)$$

Refer to table 1 for the effective diaphragm area.

When determining valve friction, you can make diaphragm pressure readings at a travel position other than mid-travel if you desire. If you take readings at zero or at the full travel position, take extra care to ensure that the readings are taken when the travel just begins or just stops at the position selected.

It is difficult to rotate the spring adjustor (key 74, figure 6, 7, and 8) when the full actuator loading pressure is applied to the actuator. Release the actuator loading pressure before adjusting. Then re-apply loading pressure to check the adjustment.

Spring Verification

Ensure that the actuator diaphragm is at the bottom of its travel as shown in figure 4 and not connected to the valve. (Note: Some spring compression is required to move the diaphragm to the **bottom** of its travel.)

Also, provide a certified pressure gauge that will accurately read the diaphragm pressure from 0 through the upper bench set pressure marked on the nameplate. Apply loading pressure to the diaphragm.

Stroke the actuator a few times to ensure that the pressure gauge is working correctly, and that the actuator is functioning properly.

CAUTION

To prevent product damage, it is important to ensure that the actuator assembly is not binding or producing any friction on the actuator stem movement.

Key numbers are shown in figures 6, 7, and 8.

For Direct-Acting Valves (PDTC)

1. If not already accomplished, push the valve stem down away from the actuator to the closed position.

2. Set the diaphragm loading pressure to 0.3 bar (5 psig) over the upper bench set pressure. The upper travel stop should be contacting the diaphragm casing.
3. Slowly decrease the pressure towards the upper bench set pressure while checking for the **first** movement of the actuator stem.

Note

Before turning the spring adjuster on size 70, 76, or 87 actuators, assemble the stem connector around the actuator stem and the anti-rotating lug on the yoke. Mark the actuator stem as a visual reference to verify that stem rotation does not occur. Remove the stem connector before rechecking the bench set.

4. If movement occurs before or after the upper pressure is reached, adjust the spring adjuster (see figure 4). Thread the adjuster up or down on the actuator stem until the actuator stem movement is **first** detected at the upper bench set pressure. (Note: You may need to lower the loading pressure to reduce spring compression, allowing the spring adjuster to turn.)
5. Be sure the spring adjuster is adjusted to meet the requirements of step 4 above.
6. Apply the lower bench set loading pressure to the diaphragm. This will extend the actuator stem toward the valve. Mark the end of the actuator stem on a nearby surface using tape or some other method.
7. Slowly increase the diaphragm pressure until the upper bench set loading pressure is applied. Again, the travel stop should be against the diaphragm casing.
8. Measure the distance between the mark or tape to the end of the actuator stem. This distance should match the travel span shown on the travel indicator scale (key 32).
9. If the span of travel is correct, bench set is complete. Proceed to the Installing the Stem Connector Assembly subsection.
10. If the travel span is not exact, remember the free-length and load rate tolerances for the spring may produce a slightly different span than specified. Contact your Emerson Process Management sales office for assistance.

For Reverse-Acting Valves (PDTO)

1. If not already accomplished, push the valve stem down away from the actuator to the open position. Later, when installing the connector, pull up the valve stem to the closed position.
2. Set the diaphragm loading pressure to a value less than the lower bench set pressure (near zero). The down travel stop should be contacting the yoke.
3. Slowly increase the pressure towards the lower bench set pressure while checking for the **first** movement of the actuator stem.

Note

Before turning the spring adjuster on size 70, 76, or 87 actuators, assemble the stem connector around the actuator stem and the anti-rotating lug on the yoke. Mark the actuator stem as a visual reference to verify that stem rotation does not occur. Remove the stem connector before rechecking the bench set.

4. If movement occurs before or after the lower pressure is reached, adjust the spring adjuster (see figure 4). Thread the adjuster up or down on the actuator stem until the actuator stem movement is **first** detected at the lower bench set pressure.
5. Apply the upper bench set loading pressure to the diaphragm. This will retract the actuator stem away from the valve. Mark the end of the actuator stem on a nearby surface using tape or some other method.
6. Slowly decrease the diaphragm pressure until the lower bench set loading pressure is applied. Again, the down-stops should be against the yoke.
7. Measure the distance between the mark or tape to the end of the actuator stem. This distance should match the travel span shown on the travel indicator scale (key 32).
8. If the span of travel is correct, bench set is complete. Proceed to the Installing the Stem Connector Assembly subsection.
9. If the travel span is not exact, remember the free-length and load rate tolerances for the spring may produce a slightly different span than specified. Contact your Emerson Process Management sales office for assistance.

Installing the Stem Connector Assembly

When installing the stem connector assembly (key 31), the actuator and valve stem threads should

667 Size 30-76 and 87 Actuators

engage the threads of the stem connector by a distance equal to the diameter of the stem.

Note

Replacement stem connectors are an assembly of two stem connector halves, cap screws, and a spacer between the connector halves. Remove the spacer and discard it, if present, before clamping the actuator and valve stems together.

1. If necessary, push the valve stem down so that the valve plug is touching the seat ring on direct-acting valves. For reverse-acting valves, pull the stem up to the closed position. Always start with the valve plug on the seat.
2. If necessary, screw the valve stem locknuts down, away from the connector location. For all actuators except size 87, ensure that the travel indicator disk (key 34) is on top of the locknuts.
3. Adjust the diaphragm pressure to the lower bench set pressure. (Or, the upper bench set pressure for reverse-acting valves.) This should be the same pressure used in the bench set steps, and it is marked on the nameplate.
4. Place the stem connector half with the threaded holes, approximately half way between the actuator and valve stems. Refer to figures 6, 7, and 8 to help locate the connector position.

Be sure that the actuator and valve stem threads are engaging the threads of the stem connector by a distance equal to one diameter of the stem.

CAUTION

Incomplete engagement of either the valve stem or actuator stem in the stem connector can result in stripped threads or improper operation. Be sure that the length of each stem clamped in the stem connector is equal to or greater than one diameter of that stem. Damage to threads on either stem or in

the stem connector can cause the parts to be replaced prematurely.

5. Install the other half of the stem connector and insert the cap screws and tighten them. If installing a positioner, also attach the feedback bracket at the same time.

CAUTION

Over-tightening the valve stem locknuts can make disassembly difficult.

6. Screw the valve stem locknuts up until the indicator disk contacts the bottom of the stem connector, or for size 87 actuators, tighten the locknuts against the stem connector. Do not overtighten the locknuts.
7. Slowly increase and then decrease pressure several times, stroking the valve from the lower bench set pressure to the upper pressure.

Be sure that the valve is in the closed position (up or down, depending on valve action). Loosen the screws on the travel scale, and align it with the travel indicator disk. Stroke the valve full travel to ensure that the travel matches the valve travel on the travel indicator plate. If valve travel is not correct, repeat the stem connector procedure.

Note

For push-down-to-close valves, the valve plug seat is the limit for downward travel and the actuator up-stop is the limit for upward (away from the valve) movement. For push-down-to-open valves, the actuator down-stop is the limit for downward movement, and the valve seat is the limit for upward (away from the valve) movement. For 667 actuators, a down-stop (key 77, figure 6) is installed to limit actuator diaphragm downward movement when the actuator provides the limit.

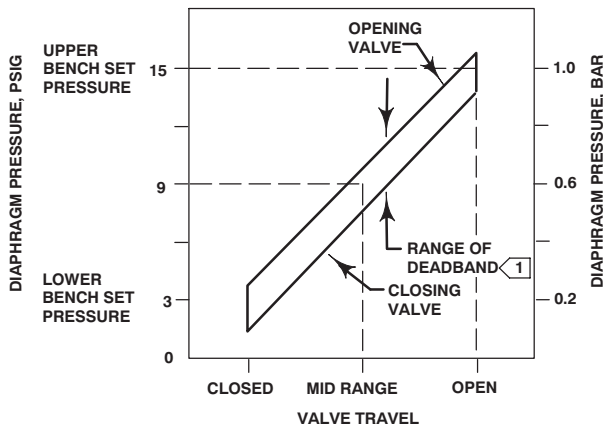

NOTE:
 1 DEADBAND IS CAUSED BY FRICTION.
 A6588-1 / IL

Figure 5. Typical Reverse-Acting Valve Response to Deadband

Deadband Measurement

Deadband is caused by packing friction, unbalanced forces, and other factors in the control valve assembly. Deadband is the range a measured signal can vary without initiating a response from the actuator (see figure 5). Each actuator spring has a fixed spring rate (force). You have verified that the right spring was installed in the actuator by completing the Bench Set Spring Adjustment steps.

Deadband is one factor that affects the control valve assembly operation during automatic loop control. The control loop tolerance for deadband varies widely depending on the loop response. Some common symptoms of the deadband being too wide are no movement, a “jump” movement, or oscillating movements of the actuator during automatic loop control. The following steps are provided to determine the span of deadband. The percent of deadband is helpful in troubleshooting problems with the process control loop.

1. Start at a pressure near the lower bench set pressure, slowly increase pressure until the valve is approximately at mid-travel. Note this pressure reading.
2. Slowly decrease pressure until movement of the valve stem is detected, and note this pressure.
3. The difference between these two pressures is deadband, in psi.
4. Calculate the percent of deadband by:
 Deadband, psi

$$\text{Deadband} = \frac{\text{Deadband, psi}}{\text{Bench Set Span, psi}} = \text{nn \%}$$

Loading Connection

Key number locations are shown in figures 6, 7, and 8, unless otherwise noted.

The loading pressure connections are made at the factory if the valve, actuator, and positioner come as a unit. Keep the length of tubing or piping as short as possible to avoid transmission lag in the control signal. If a volume booster, valve positioner or other accessory is used, be sure that it is properly connected to the actuator. Refer to the positioner instruction manual or other manuals as necessary. For actuators shipped separately or whenever the actuator pressure connections are installed, use the following steps:

1. Connect the loading pressure piping to the NPT internal connection in the side of the yoke (key 73).
2. For size 70 and 87 actuators, if necessary, remove the 1/4 NPT bushing if a 1/2 NPT internal connection is needed to increase connection size. The connection can be made with either piping or tubing.
3. Cycle the actuator several times to be sure that the valve stem travel is correct when the correct pressure ranges are applied to the diaphragm.
4. If valve stem travel appears to be incorrect, refer to the Bench Set Spring Adjustment procedures at the beginning of this section. Do not place the valve in service if it is not reacting correctly to diaphragm loading pressure changes.

Maintenance

Actuator parts are subject to normal wear and must be inspected regularly and replaced when necessary. The frequency of inspection and replacement depends on the severity of service conditions.

⚠ WARNING

Avoid personal injury or property damage from sudden release of process pressure or uncontrolled movement of parts. Before performing any maintenance operations:

- Always wear protective gloves, clothing, and eyewear when

667 Size 30-76 and 87 Actuators

performing any maintenance operations to avoid personal injury.

- **Disconnect any operating lines providing air pressure, electric power, or a control signal to the actuator. Be sure the actuator cannot suddenly open or close the valve.**

- **Use bypass valves or completely shut off the process to isolate the valve from process pressure. Relieve process pressure from both sides of the valve. Drain the process media from both sides of the valve.**

- **Vent the power actuator loading pressure and relieve any actuator spring pre-compression.**

- **Use lock-out procedures to be sure that the above measures stay in effect while you work on the equipment.**

- **The valve packing box may contain process fluids that are pressurized, even when the valve has been removed from the pipeline. Process fluids may spray out under pressure when removing the packing hardware or packing rings, or when loosening the packing box pipe plug.**

- **Check with your process or safety engineer for any additional measures that must be taken to protect against process media.**

The maintenance instructions are divided into several sections: Actuator, Top-Mounted Handwheel Assembly (Adjustable Down Travel Stop), Side-Mounted Handwheel Assembly for Size 34 through 60 Actuators (Manual Actuator), Side-Mounted Handwheel Assembly for Size 70, 76 and 87 Actuators (Manual Actuator), and Casing-Mounted Travel Stops.

Actuator

This procedure describes how the actuator can be completely disassembled and assembled. When inspection or repairs are required, disassemble only those parts necessary to accomplish the job; then, start the assembly at the appropriate step.

Key numbers are shown in figures 6, 7, or 8, unless otherwise noted. Figure 6 shows the size 30 through

60 actuators, figure 7 shows the size 70 actuator, and figure 8 shows the size 87 actuator.

Actuator Disassembly

Isolate the control valve from the line pressure, release pressure from both sides of the valve body, and drain the process media from both sides of the valve. Also shut off all pressure lines to the power actuator, release all pressure from the actuator. Use lock-out procedures to be sure that the above measures stay in effect while you work on the equipment.

1. Remove the tubing or piping from the connection in the top of the yoke (key 73). For a top-loaded construction, also remove the piping or tubing from the connection in the upper diaphragm casing (key 1).

2. Turn the spring adjuster (key 74) counterclockwise (**toward the valve body**) until all spring compression is relieved.

WARNING

To avoid personal injury due to the sudden uncontrolled movement of parts, do not loosen the stem connector cap screws when the stem connector has spring force applied to it.

3. If necessary, remove the actuator from the valve body by separating the stem connector (key 31). Loosen the stem locknuts for the size 87 actuator, and remove the stem connector nuts. For all other sizes, separate the stem connector by loosening the stem locknuts (keys 69 and 75) and unscrewing the two stem connector cap screws.

4. Unscrew the spring adjuster (key 74) from the actuator stem (key 144). Also lift the spring seat and spring (key 19 and 18) out of the yoke.

5. Remove the diaphragm casing cap screws and nuts (keys 13 and 14), and lift off the upper diaphragm casing (key 1).

CAUTION

Be careful during disassembly to avoid damaging the O-rings (key 8).

6. Remove the following connected parts: the diaphragm (key 3), upper diaphragm plate (key 4), spacer (key 2), cap screw (key 12), lower diaphragm plate (key 71), and actuator stem (key 144). Be

careful when pulling the threads of the actuator stem through the seal bushing (key 7) to avoid damaging the O-rings (key 8).

7. Remove the cap screw (key 12) to separate the parts of this assembly.
8. To remove the seal bushing, remove the snap ring (key 72), and lift out the bushing. Inspect, and if necessary, replace O-rings (8 and 9).
9. Remove cap screws (key 30), and take off the lower diaphragm casing (key 64) and the gasket (key 70, size 30 through 60 and 76) or O-ring (key 70, size 70 or 87). If necessary, the down travel stops (key 77) can be removed.

Actuator Assembly

1. Coat the O-rings (key 70, sizes 70 and 87) with lithium grease (key 237), or, coat the gasket with lithium grease (key 237). Place a new gasket or O-ring (key 70) on the yoke (key 73). Position the lower diaphragm casing (key 64) on the yoke and align the holes. Insert the cap screws (key 30) and tighten evenly in a crisscross pattern to 41 N•m (30 lbf•ft) for size 30-60 and 76 actuators or 95 N•m (70 lbf•ft) for size 70 and 87 actuators. If down travel stops (key 77) were removed, insert and tighten them.
2. Coat the O-rings (keys 8 and 9) with lithium grease (key 237) and place the O-rings in the seal bushing (key 7).
3. Fill the seal bushing with lithium grease (key 237), slide the bushing into the yoke (key 73), and install the snap ring (key 72).

CAUTION

Be careful during assembly to avoid damaging the O-rings (key 8).

4. Assemble the actuator stem (key 144), lower diaphragm plate (key 71), diaphragm (key 3), upper diaphragm plate (key 4), and the travel stop cap screw and spacer (keys 12 and 2). Coat the cap screw threads with lithium grease (key 237). Tighten the cap screw (key 12) to 41 N•m (30 lbf•ft) torque for size 30 actuators, 68 N•m (50 lbf•ft) torque for size 34 and 40 actuators, or 183 N•m (135 lbf•ft) torque for size 45 to 76 and 87 actuators. Place this assembly in the actuator. Take care when pushing the actuator stem through the seal bushing so that the threads do not damage the O-rings.

Note

When you replace actuator diaphragms in the field, take care to ensure the diaphragm casing bolts are tightened to the proper load to prevent leakage, but not crush the material. Perform the following tightening sequence with a manual torque wrench for size 30-76 and 87 actuators.

CAUTION

Over-tightening the diaphragm cap screws and nuts (keys 13 and 14) can damage the diaphragm. Do not exceed 27 N•m (20 lbf•ft) torque.

Note

Do not use lubricant on these bolts and nuts. Fasteners must be clean and dry.

5. Install the upper diaphragm casing (key 1), and install the cap screws and nuts (keys 13 and 14). Tighten the diaphragm cap screws and nuts in the following manner.
6. The first four bolts tightened should be diametrically opposed and 90 degrees apart. Tighten these four bolts to 13 N•m (10 lbf•ft).
7. Tighten the remaining bolts in a clockwise, criss-cross pattern to 13 N•m (10 lbf•ft).
8. Repeat this procedure by tightening four bolts, diametrically opposed and 90 degrees apart, to a torque of 27 N•m (20 lbf•ft).
9. Tighten the remaining bolts in a clockwise, criss-cross pattern to 27 N•m (20 lbf•ft).
10. After the last bolt is tightened to 27 N•m (20 lbf•ft), all of the bolts should be tightened again to 27 N•m (20 lbf•ft) in a circular pattern around the bolt circle.
11. Once completed, no more tightening is recommended.
12. Install the actuator spring (key 18) and spring seat (key 19). Apply anti-seize lubricant (key 239) to the threads of the actuator stem and to the surface of the spring adjuster (key 74) that contacts the spring seat. Thread the spring adjuster onto the actuator stem.

667 Size 30-76 and 87 Actuators

13. Mount the actuator onto the valve in accordance with the procedures in the Installation section.

Top-Mounted Handwheel Assembly (Adjustable Down Travel Stop)

Actuator key numbers are shown in figures 6, 7, and 8. And, top-mounted handwheels are shown in figures 9, 11, and 12.

Note

If repeated or daily manual operation is expected, the actuator should be equipped with a side-mounted handwheel rather than a casing-mounted travel stop or top-mounted handwheel. The side-mounted handwheel is designed for more frequent use as a manual operator.

A top-mounted handwheel assembly (figures 9, 11, and 12) is usually used as an adjustable down travel stop to limit full extension of the actuator stem.

Turning the handwheel counterclockwise pulls the extension rod (key 150, figures 9, 11, and 12) up, retracting the actuator stem.

Instructions are given below for complete disassembly and assembly. Perform the disassembly only as far as necessary to accomplish the required maintenance; then, begin the assembly at the appropriate step.

Disassembly for Top-Mounted Handwheel

1. Bypass the control valve, reduce loading pressure to atmospheric, and remove the tubing or piping from the connection in the top of the yoke (key 73, figures 6, 7, and 8).
2. Turn the handwheel (key 58) clockwise so that the handwheel assembly is not causing any spring compression.
3. Turn the actuator spring adjuster (key 74) to relieve all the compression from the spring (key 18).
4. If servicing just the thrust bearing, races, and handwheel screw (keys 180, 181, and 160), use the following steps:

- Remove the cap and take out the cotter pin. Remove the castle nut, bearing retainer, thrust bearing, and races (keys 247, 167, 166, 180, and 181).

- Use the handwheel to remove the handwheel screw (key 160) from the handwheel body (key 148).

- If necessary, remove the extension rod (key 150) at this time. Most maintenance procedures do not require the rod to be removed.

- Clean and inspect all parts or replace parts as necessary. Upon re-assembly, lubricate handwheel threads, bearings, and races with anti-seize lubricant (key 239).

- Lubricate and re-install the handwheel screw into handwheel body (key 148). Lubricate and replace the races, bearing, and retainer (keys 181, 180, and 182). Replace the castle nut (key 166), tighten it, and insert the cotter pin (key 167). Replace the handwheel cap (key 247).

5. For size 30 through 60 and 76 actuator handwheels (figures 9 and 11):

- Remove the cap screws (key 161). Make sure that the guide plate can turn between the handwheel body and the mounting plate (keys 157, 148 and 158).

- Remove the cap (key 247) and cotter pin (key 167). Remove the castle nut (key 166) and, if necessary, unscrew the extension rod (key 150). Remove the rod, the handwheel body (key 148), and the attached parts.

- Remove the hex nuts and cap screws (keys 14 and 13, figures 6, 7, and 8) from the diaphragm casings. Lift off the upper diaphragm casing (key 1) and the mounting plate (key 158).

- Turn the handwheel (key 58) to remove the handwheel screw (key 160) from the handwheel body (key 148). Remove the retaining ring (key 60) if the handwheel (key 58) must be separated from the handwheel screw.

- If necessary, perform other actuator maintenance before returning to the following assembly steps.

6. For size 70 and 87 actuator handwheels (figure 12):

- Remove the cap (key 247). Take out the cotter pin (key 167) and remove the castle nut, the bearing retainer, and thrust bearing (keys 166, 182, 181, and 180). It is not necessary to remove the extension rod (key 150) at this time.

- Remove the hex nuts and cap screws (keys 14 and 13, figures 6, 7, and 8) from the diaphragm

casings. Lift off the upper diaphragm casing (key 1), handwheel body (key 148) and attached parts.

- If travel stops (key 152) are used, note and record their position relative to the cap screws (key 154) for use in assembly. Remove the travel stops and cap screws, and remove either the mounting plate (key 158, figure 12) or the handwheel body (key 148, figure 12) and attached parts.

- Turn the handwheel (key 58) to remove the handwheel screw (key 160) from the handwheel body (key 148). Remove the retaining ring (key 60) if the handwheel (key 58) must be separated from the handwheel screw.

- If necessary, perform other actuator maintenance before returning to the following assembly steps.

Assembly for Top-Mounted Handwheel

For size 30 through 60 and 76 actuator handwheels:

Refer to figures 9 and 11 for top-mounted handwheel assemblies.

1. If it was removed, slide the handwheel (key 58) onto the end of the handwheel screw (key 160), and snap the retaining ring (key 60) into place. Also, install the guide post (key 150) if it was removed.
2. Generously coat the threads of the handwheel screw (key 160) with anti-seize lubricant (key 239). Turn the screw into the handwheel body (key 148).
3. Install the mounting plate (key 158) to the diaphragm casing (key 1, figures 6, 7, and 8) with the cap screws (key 154). Finger tighten the screws.
4. If travel stops were used, install the travel stops to their original positions as recorded in the proceeding Disassembly steps. Tighten the screws and travel stops.

Note

When you replace actuator diaphragms in the field, take care to ensure the diaphragm casing bolts are tightened to the proper load to prevent leakage, but not crush the material. Perform the following tightening sequence with a manual torque wrench for size 30-76 and 87 actuators.

CAUTION

Over-tightening the diaphragm cap screws and nuts (keys 13 and 14) can damage the diaphragm. Do not exceed 27 N•m (20 lbf•ft) torque.

Note

Do not use lubricant on these bolts and nuts. Fasteners must be clean and dry.

5. Position the diaphragm casing (key 1, figures 6, 7, and 8), mounting plate (key 158), travel stops (key 152), if used, and cap screws (key 154) on the diaphragm. Install the cap screws and hex nuts (keys 13 and 14, figures 6, 7, and 8) and tighten in the following manner.
6. The first four bolts tightened should be diametrically opposed and 90 degrees apart. Tighten these four bolts to 13 N•m (10 lbf•ft).
7. Tighten the remaining bolts in a clockwise, criss-cross pattern to 13 N•m (10 lbf•ft).
8. Repeat this procedure by tightening four bolts, diametrically opposed and 90 degrees apart, to a torque of 27 N•m (20 lbf•ft).
9. Tighten the remaining bolts in a clockwise, criss-cross pattern to 27 N•m (20 lbf•ft).
10. After the last bolt is tightened to 27 N•m (20 lbf•ft), all of the bolts should be tightened again to 27 N•m (20 lbf•ft) in a circular pattern around the bolt circle.
11. Once completed, no more tightening is recommended.
12. If necessary, screw the extension rod (key 150) into the connector (key 27). Slide the guide plate (key 157) onto the extension rod (key 150). For size 45 through 76, place the spacer (key 253) on top of the guide plate (key 157). If necessary, replace the extension rod (key 150). Slide the handwheel body (key 148) over the extension rod, position the handwheel body on the spacer (key 253), align the holes, and insert and tighten the cap screws (key 161).
13. Lubricate and install the thrust bearings (keys 181 and 180), install the bearing retainer (key 182), install the castle nut (key 166) on the extension rod. Do not overtighten the castle nut on

667 Size 30-76 and 87 Actuators

the bearing. Install the cotter pin (key 167). Replace the cap (key 247).

14. Refer to the Assembly portion of the Actuator maintenance section.

For size 70 and 87 actuators handwheels (figure 12):

Refer to figure 12 for top-mounted handwheel assemblies.

1. If removed, slide the handwheel (key 58) onto the end of the handwheel screw (key 160), and snap the retaining ring (key 60) into place.
2. Generously coat the threads of the handwheel screw (key 160) with anti-seize lubricant (key 239). Turn the screw into the handwheel body (key 148).
3. If necessary, install the extension rod (key 150) into the connector (key 27) and tighten it. Position the handwheel body (key 148) on the diaphragm casing (key 1, figures 6, 7, and 8), and align the holes. Insert the cap screws (key 154). Finger tighten the screws.
4. If travel stops were used, return the travel stops to their original positions as recorded in the preceding Disassembly steps. Tighten the screws and travel stops.

Note

When you replace actuator diaphragms in the field, take care to ensure the diaphragm casing bolts are tightened to the proper load to prevent leakage, but not crush the material. Perform the following tightening sequence with a manual torque wrench for size 30-76 and 87 actuators.

CAUTION

Over-tightening the diaphragm cap screws and nuts (keys 13 and 14) can damage the diaphragm. Do not exceed 27 N•m (20 lbf•ft) torque.

Note

Do not use lubricant on these bolts and nuts. Fasteners must be clean and dry.

5. Slide the extension rod (key 150) into the handwheel screw (key 160), and position the diaphragm casing (key 1, figures 6, 7, and 8) with

the attached parts on the diaphragm. Install the cap screws and hex nuts (keys 13 and 14, figures 6, 7, and 8) and tighten in the following manner.

6. The first four bolts tightened should be diametrically opposed and 90 degrees apart. Tighten these four bolts to 13 N•m (10 lbf•ft).
7. Tighten the remaining bolts in a clockwise, criss-cross pattern to 13 N•m (10 lbf•ft).
8. Repeat this procedure by tightening four bolts, diametrically opposed and 90 degrees apart, to a torque of 27 N•m (20 lbf•ft).
9. Tighten the remaining bolts in a clockwise, criss-cross pattern to 27 N•m (20 lbf•ft).
10. After the last bolt is tightened to 27 N•m (20 lbf•ft), all of the bolts should be tightened again to 27 N•m (20 lbf•ft) in a circular pattern around the bolt circle.
11. Once completed, no more tightening is recommended.

12. Lubricate and install the thrust bearings (keys 180 and 181), install the bearing retainer (key 182), install the castle nut (keys 166) on the extension rod. Do not overtighten the castle nut on the bearing. Install the cotter pin (key 167). Replace the cap (key 247).

13. Refer to the Assembly portion of the Actuator maintenance section.

Side-Mounted Handwheel Assembly for Size 34 through 60 Actuators

A side-mounted handwheel assembly (figures 13 and 14) is usually used as a manual actuator. This design is frequently used to drive the valve open or closed under loading conditions. Turning the handwheel clockwise past the neutral position always closes a push-down-to-close valve. A pair of levers (key 146, figure 13) on a handwheel assembly close the valve by moving the valve stem.

Instructions are given below for disassembly and assembly. Perform the disassembly only as far as necessary to accomplish the required maintenance; then begin the assembly at the appropriate step.

Disassembly for Side-Mounted Handwheel (34-60)

1. If desired, the handwheel assembly can be removed from the actuator yoke. To do this, remove

the nuts (keys 147 and 170) from the U-bolts (keys 166 and 143) that hold the assembly to the yoke.

2. Remove the retaining ring (key 154), and drive out the lever pivot pin (key 153).
3. Two screws (key 156) hold the right- and left-hand levers (key 146) together. Remove the screw from the top of the levers so that the levers will drop down out of the assembly. Disassemble further, if necessary, by removing the other screw.
4. Remove the screw (key 161) and pointer mounting bolt (key 159, not shown) located behind the pointer (key 160).
5. Remove the nut (key 54), lockwasher (key 150), and washer (key 149), and take off the handwheel (key 51). Be careful not to lose the small ball (key 55) and spring (key 56).
6. Unscrew the bearing retainer (key 136) after loosening the locking set screw (key 168, not shown).
7. Pull the screw assembly (key 145) out of the handwheel body. The operating nut (key 132) will come out with the screw. Also, remove the bushing (key 151) on sizes 34 and 40.
8. If required, remove the bearings (key 152), one from the bearing retainer and the other from the handwheel body.

Assembly for Side-Mounted Handwheel (Sizes 34-60)

1. Pack the bearings (key 152) with anti-seize lubricant (key 239). Insert one bearing and the bushing (key 151) in the handwheel body (key 142) as shown in figure 13 or 14. The bushing is not used in a handwheel assembly for size 45 through 60 actuators.
2. Coat the screw threads with anti-seize lubricant (key 239), and thread the operating nut onto the screw. Slide the second bearing (key 152) onto the screw, and insert the end of the screw into either the bushing (key 151) as shown in figure 13 or 14 or into the bearing.
3. Thread the bearing retainer (key 136) into the body (key 142). Completely tighten the bearing retainer, and then loosen it one-quarter turn. Tighten the set screw (key 168, not shown) to hold the bearing retainer in place.
4. Coat the groove in the handwheel body (key 142) with lithium grease (key 237). Insert the spring (key 56) and ball (key 55) into the handwheel (key 51). Holding the ball and spring in the handwheel, put the handwheel (key 51), the washer

(key 149), the lockwasher (key 150), and the hex nut (key 54) on the end of the screw (key 145). Tighten the hex nut.

5. Position the pointer mounting bolt (key 159, not shown) and the pointer (key 160) as shown in figure 13 or 14. Insert and tighten the screw (key 161).
6. Assemble the two levers (key 146) with the cap screws (key 156) for handwheel assemblies for size 45, 50, and 60 actuators or with the machine bolts (key 156) for handwheel assemblies on size 34 and 40 actuators.
7. If the handwheel assembly was removed from the yoke, remount the handjack assembly to the yoke using the dowel pins for alignment. Position the U-bolts (keys 166 and 143) on the yoke, and hand-tighten the hex nuts (keys 170 and 147) to hold the handwheel assembly in position. Cap screws (key 163) should be tight against the yoke legs to provide stability. Tighten nuts (key 144). Finish tightening the U-bolt nuts to 163 N•m [120 lbf•ft] (key 170) and 41 N•m [30 lbf•ft] (key 147). Be sure the handwheel assembly remains flat against the mounting pad and perpendicular to the yoke.
8. Position the levers (key 146) as shown in figure 13 or 14. Insert the lever pivot pin (key 153), and snap the retaining ring (key 154) onto the lever pivot pin.

Side-Mounted Handwheel Assembly for Size 70, 76, and 87 Actuators

A side-mounted handwheel assembly (figure 15) is usually used as a manual actuator. Turning the handwheel clockwise past the neutral position always closes the valve body. A sleeve (key 123, figure 15) on a handwheel assembly for a size 70, 76 or 87 actuator opens the valve body by moving the valve stem.

Instructions are given below for complete disassembly and assembly. Perform the disassembly only as far as necessary to accomplish the required maintenance; and then begin the assembly at the appropriate step.

Disassembly for Side-Mounted Handwheel (Sizes 70, 76, and 87)

1. Bypass the control valve. Reduce the loading pressure to atmospheric. Disconnect the loading pressure tubing or piping at the yoke.
2. Remove the cover band (key 87), and relieve spring compression by turning the spring adjuster (key 74) counterclockwise.
3. Remove the cap screws and nuts (keys 13 and 14) and lift off the upper diaphragm casing (key 1).

667 Size 30-76 and 87 Actuators

4. Remove the travel stop screw (key 12) and spacer (key 2), and take off the diaphragm plate (key 4), the diaphragm (key 3), and the lower diaphragm plate (key 71).
5. Unscrew the cap screws (key 90) and remove the following connected parts: the lower diaphragm casing (key 64), the O-ring (key 70), spring case adaptor (key 89), the seal bushing, O-rings, and snap ring (keys 7, 8, 9, and 72).
6. Remove the snap ring (key 72), and slide the seal bushing and O-rings (keys 7, 8, and 9) out of the spring case adaptor (key 89).
7. Take out the actuator spring (key 18).
8. Remove the stem connector (key 31) and stem connector cap screws.
9. Pull the actuator stem (key 144) up and out of the yoke. The spring seat (key 19), spring adjuster (key 74), thrust bearing (key 128), and the pinned adjusting screw (key 131) will come out with the actuator stem.
10. Turn the handwheel so that the lower sleeve (key 123) extends out of the bottom of the yoke. DO NOT move the neutral indicator scale (key 125).
11. Loosen two set screws (key 121), and unscrew the bearing retainer flange (key 45). Take out the worm gear and two thrust bearings (key 132), one on each side of the gear.
12. The worm shaft (key 51) and associated parts can be disassembled, if desired, by first removing the handwheel nut (key 127) and the handwheel (key 58). Do not lose the small ball (key 141) and spring (key 142).
13. Loosen the set screw (key 52) for each worm shaft retainer (keys 48 and 49). Unscrew the two worm retainers (keys 48 and 49). The ball bearings (key 50) will come out with the retainers.

Assembly for Side-Mounted Handwheel (Sizes 70, 76, and 87)

1. The front and back worm retainers (keys 48 and 49) each have a slot in their threads for a set screw (key 52). Pack the ball bearings (key 50) with anti-seize lubricant (key 239), and insert one ball bearing in the back worm retainer (key 49) as shown in figure 15.
2. Thread the back bearing retainer and ball bearing (keys 49 and 50) into the yoke. Align the slot in the bearing retainer with the set screw hole in the yoke, insert the set screw (key 52), and tighten it.
3. Coat the worm shaft (key 51) threads with anti-seize lubricant (key 239), and slide the shaft into the yoke so that the end of the shaft fits snugly into the back bearing retainer.
4. Insert the bearing in the front bearing retainer (key 49), and thread the retainer and ball bearing into the yoke. Align the slot in the retainer with the hole in the yoke, insert the set screw (key 52), and tighten it.
5. Put the spring and ball (keys 141 and 142) in the handwheel (key 58). Slide the handwheel onto the worm shaft (key 51). Thread the hex nut (key 127) onto the worm shaft.
6. Pack the two needle bearings (key 132) and coat the worm gear (key 44) threads with anti-seize lubricant (key 239). Insert the key (key 122), the bearings, and the worm gear in the yoke (key 73) as shown in figure 15.
7. Slots are cut in the threads of the bearing retainer flange (key 45). Thread the flange into the yoke so that the slots and the holes for the set screws (key 121) align. Insert the screws, and tighten them.
8. The lower sleeve (key 123) has a milled groove in one end. Coat the sleeve threads with anti-seize lubricant (key 239), slide the end of the lower sleeve with the groove into the bearing retainer flange, turn the handwheel, and feed the sleeve through the worm gear so that the slot in the lower sleeve engages the key (key 122) in the yoke. Continue turning the handwheel until the lower sleeve protrudes 81 mm (3.19 inches) below the surface of the yoke. The bottom of the lower sleeve should be even with the bottom of the extension on the neutral indicator.
9. Pack the thrust bearing (key 128) with anti-seize lubricant (key 239). Slide the actuator stem (key 144) and the attached adjusting screw (key 131), pin (key 130), thrust bearing (key 128), spring seat (key 19), and spring adjuster (key 74) into the yoke. The lower end of the stem slides through the lower sleeve (key 123) and the lower sleeve slides into the adjusting screw (key 131), as shown in figure 15.
10. Position the actuator stem (key 144) against the valve stem. Clamp both stems between the two halves of the stem connector (key 31), and be sure the threads are engaged properly on both stems. The stem connector should not be closer than 3.2 mm (1/8 inches) to the lower sleeve when the actuator stem is in the retracted position. This adjustment will provide approximately 3.2 mm (1/8 inches) of free travel of the lower sleeve in either direction for manual operation. Fasten the halves together with the cap screws.

11. Put the actuator spring (key 18) in the yoke on the spring seat (key 19).
12. Coat the O-rings (keys 8 and 9) with lithium grease (key 237), and insert them in the seal bushing (key 7). Slide the seal bushing and O-rings into the spring case adaptor (key 89).
13. Install the snap ring (key 72).
14. Slide the seal bushing and O-rings (keys 7, 8, and 9) over the actuator stem (key 144), and position the spring case adaptor (key 89), lower diaphragm casing (key 64), and O-ring (key 70) on the yoke.
15. Insert and tighten the cap screws (key 90).
16. Slide the lower diaphragm plate (key 71), the diaphragm (key 3) with the patterned side up, the diaphragm plate (key 4), the spacer (key 2), and the cap screw (key 12) on the actuator stem (key 144). Tighten the cap screw.
17. Put the diaphragm casing (key 1) on the diaphragm. Align the holes in the diaphragm (key 3) and the diaphragm casings (keys 1 and 64).

Note

When you replace actuator diaphragms in the field, take care to ensure the diaphragm casing bolts are tightened to the proper load to prevent leakage, but not crush the material. Perform the following tightening sequence with a manual torque wrench for size 30-76 and 87 actuators.

CAUTION

Over-tightening the diaphragm cap screws and nuts (keys 13 and 14) can damage the diaphragm. Do not exceed 27 N•m (20 lbf•ft) torque.

Note

Do not use lubricant on these bolts and nuts. Fasteners must be clean and dry.

18. Install the cap screws and hex nuts (keys 13 and 14) and tighten in the following manner.
19. The first four bolts tightened should be diametrically opposed and 90 degrees apart. Tighten these four bolts to 13 N•m (10 lbf•ft).

20. Tighten the remaining bolts in a clockwise, criss-cross pattern to 13 N•m (10 lbf•ft).
21. Repeat this procedure by tightening four bolts, diametrically opposed and 90 degrees apart, to a torque of 27 N•m (20 lbf•ft).
22. Tighten the remaining bolts in a clockwise, criss-cross pattern to 27 N•m (20 lbf•ft).
23. After the last bolt is tightened to 27 N•m (20 lbf•ft), all of the bolts should be tightened again to 27 N•m (20 lbf•ft) in a circular pattern around the bolt circle.
24. Once completed, no more tightening is recommended.
25. Return the actuator to service after completing the Loading Connection procedure in the Installation section and the procedures in the Adjustments section.

Casing-Mounted Travel Stops

Note

If repeated or daily manual operation is expected, the actuator should be equipped with a side-mounted handwheel rather than a casing-mounted travel stop or top-mounted handwheel. The side-mounted handwheel is designed for more frequent use as manual operator.

Casing-mounted adjustable travel stops (shown in figures 16 through 20) are available to limit travel in the down direction (extending the actuator stem) or in the up direction (retracting the actuator stem). The travel stop in figure 16 is a down travel stop, the travel stop in figure 17 is an up and down travel stop, and the travel stops in figures 18, 19, and 20 are up travel stops.

Use the locknuts (key 151, figures 16 and 17), stem (key 150, figure 18), handwheel (key 58, figure 19) or cap screw (key 177, figure 20) to set the point at which the travel stop limits travel. Be sure to tighten the locknuts and replace the cap (key 149, figures 16 and 18; key 247, figure 17) after setting the travel stop.

Instructions are given below for disassembly and assembly. Perform the disassembly only as far as necessary to accomplish the required maintenance; then, begin the assembly at the appropriate step.

667 Size 30-76 and 87 Actuators

Key numbers are shown in figures 16 through 20.

1. Remove the cap (key 149 or 247) if the travel stop uses one. For down travel stops, loosen the locknuts (key 151, figures 16 and 17) so that the stop is not causing any spring compression.
2. Bypass the control valve, reduce loading pressure to atmospheric, and remove the tubing or piping from the connection on top of the yoke (key 73, figures 6, 7, and 8).
3. For down travel stops, turn the spring adjuster (key 74, figures 6, 7, and 8) out of the yoke toward the stem connector (key 31) to relieve all the compression in the spring (key 18).
4. **For style 11 travel stops (figure 17)**, unscrew the cap screws (key 161), and make sure that the guide plate (key 157) can turn between the handwheel body (key 148) and the mounting plate (key 158).
5. Use a wrench on the nuts (key 151) to unscrew the extension rod (key 150). Remove the rod, the handwheel body (key 148), and the attached parts.
6. Unscrew the hex nuts and cap screws (keys 14 and 13, figures 6, 7, and 8) from the diaphragm casings. Lift off the upper diaphragm casing (key 1, figures 6, 7, and 8) and, for the style 11 travel stop, the mounting plate (key 158). For styles 10, 12 and 13, the travel stop assembly will be removed with the casing.
7. Note and record the position of travel stops (key 152) relative to the cap screws (key 154) for use in assembly. Unscrew the travel stops and cap screws, and remove either the mounting plate (key 158) or the handwheel body (key 148) and attached parts.
8. Separate the stem (key 150) and screw (key 160, figure 17) from the handwheel body.
9. Before reassembling, lubricate parts indicated by key 239 in figures 16 through 20. Use anti-seize lubricant (key 239).
10. Reassemble parts in the reverse order of removal.
11. When replacing the cap screws (key 154) and, if used, the travel stops (key 152), be sure to return them to their original position as recorded in step 6.

CAUTION

Over-tightening the diaphragm cap screws and nuts (keys 13 and 14), figures 6, 7, and 8 can damage the diaphragm. Do not exceed 27 N•m (20 lbf•ft) torque.

12. Install the cap screws and nuts (keys 13 and 14, figures 6, 7, and 8) and finger tighten. Tighten the diaphragm cap screws and nuts to 27 N•m (20 lbf•ft) torque in a crisscross pattern.
13. Return the spring adjuster (key 74, figure 6, 7, and 8) to its original position. Re-adjust the travel stop.

Parts Ordering

Each actuator has a serial number stamped on the nameplate. Always mention this number when corresponding with your Emerson Process Management sales office regarding technical information or replacement parts. Also, reference the complete 11-character part number of each needed part as found in the following Parts Kits and Parts List sections.

WARNING

Use only genuine Fisher® replacement parts. Components that are not supplied by Emerson Process Management should not, under any circumstances, be used in any Fisher valve, because they may void your warranty, might adversely affect the performance of the valve, and could cause personal injury and property damage.

Note

Neither Emerson, Emerson Process Management, nor any of their affiliated entities assumes responsibility for the selection, use, or maintenance of any product. Responsibility for the selection, use, and maintenance of any product remains with the purchaser and end-user.

Parts Kits

Side-Mounted Handwheels Retrofit Kits

Key	Description	Part Number
Retrofit Kit includes parts to add a Side-Mounted Handwheel.		
	Size 34 Push-Down-To-Close	30A8778X0E2
	Size 34 Push-Down-To-Open	30A8778X0F2
	Size 40 Push-Down-To-Close	30A8778X0G2
	Size 40 Push-Down-To-Open	30A8778X0H2
	Size 45 & 46 Push-Down-To-Close	40A8779X0A2
	Size 45 & 46 Push-Down-To-Open	40A8779X0B2
	Size 50 & 60 Push-Down-To-Close	40A8779X0C2
	Size 50 & 60 Push-Down-To-Open	40A8779X0D2

Top-Mounted Handwheels Retrofit Kits

Retrofit Kit includes parts to add a Top-Mounted Handwheel. Kit number 1 includes the handwheel assembly only. Kit number 2 includes Kit number 1 and a new diaphragm case that is required to mount the handwheel assembly.

Key	Description	Part Number
Kit 1		
	Size 30	30B3940X102
	Sizes 34	39B3940X022
	Size 40	39B3940X042
	Sizes 45 & 50	33B9224X012
	Sizes 46, 60, & 76	33B9224X012
	Sizes 70 & 87	CV8060X0012
Kit 2		
	Size 30	30B3940X052
	Size 34	30B3940X062
	Size 40	30B3940X092
	Sizes 45 & 50	33B9224X022
	Sizes 46, 60, & 76	33B9224X032
	Sizes 70 & 87	CV8060X0022

Actuator Repair Kits

Parts kit includes keys 8, 9, and 70. O-ring material is nitrile, and gasket material is composition.

Key	Description	Part Number
	Size 30	R667X000302
	Sizes 34 & 40	R667X000402
	Sizes 45 through 60	R667X000502
	Sizes 70 & 87	R667X000702
	Size 76	R667X000762

Parts List

Note

Part numbers are shown for recommended spares only. For part numbers not shown, contact your Emerson Process Management sales office.

Actuator Assembly

Key	Description	Part Number	Qty
1	Upper Diaphragm Casing		
2	Travel Stop Spacer		
3*	Diaphragm		
	Molded Nitrile/Nylon		
	Size 30	2E800002202	1
	Sizes 34 & 40	2E669902202	1
	Sizes 45 & 50	2E859602202	1
	Sizes 46, 60 & 76	2E859802202	1
	Sizes 70 & 87	2N130902202	1
	Molded Silicone/Polyester		
	Size 30	18B2713X012	1
	Sizes 34 & 40	18B2713X022	1
	Sizes 45 & 50	18B2713X032	1
	Sizes 46, 60 & 76	18B2713X042	1
	Sizes 70 & 87	18B2713X052	1
4	Upper Diaphragm Plate		
7*	Bushing, Seal		
	Brass		
	Size 30	1E791214012	1
	Sizes 34 & 40	1E682814012	1
	Sizes 45 through 60	1E845714012	1
	Sizes 70, 76 & 87	1N1316X0052	1
	S41600 [416 stainless steel (SST)]		
	Size 30	1E7912X0012	1
	Sizes 34 & 40	1E6828X0012	1
	Sizes 45 through 60	1E8457X0012	1
	PTFE w/25% Glass		
	Sizes 70, 76 & 87	1N1316X0042	1
8*	O-Ring		
	Nitrile		
	Size 30	1E5914X0052	2
	Sizes 34 & 40	1D237506992	2
	Sizes 45 through 60	1C5622X0022	2
	Sizes 70, 76 & 87	1E736906992	2
	Fluorocarbon		
	Size 30	1E5914X0062	2
	Sizes 34 & 40	1D237506382	2
	Sizes 45 through 60	1N285406382	2
	Sizes 70, 76, & 87	1N1633X0012	2
9*	O-Ring		
	Nitrile		
	Sizes 30 through 40	1C415706992	1
	Sizes 45 through 87	1E845806992	1
	Fluorocarbon		
	Sizes 30 through 40	1C4157X0032	1
	Sizes 45 through 87	1E8458X0022	1
12	Screw, Cap, hex hd		
13	Hex hd Cap Screw		
14	Hex Nut		
17	Vent Assembly		
18	Spring		
19	Seat, Lower Spring		
27	Extension Rod Conn		
30	Hex hd Cap Screw		
31	Stem Connector Assembly		
32	Travel Indicator Scale		
33	Screw, Self Tapping		
33	Screw, Mach, Fill hd		
34	Disk, Travel Indicator		
39	Nameplate		
40	Screw, Drive		
64	Lower Diaphragm Casing		

667 Size 30-76 and 87 Actuators

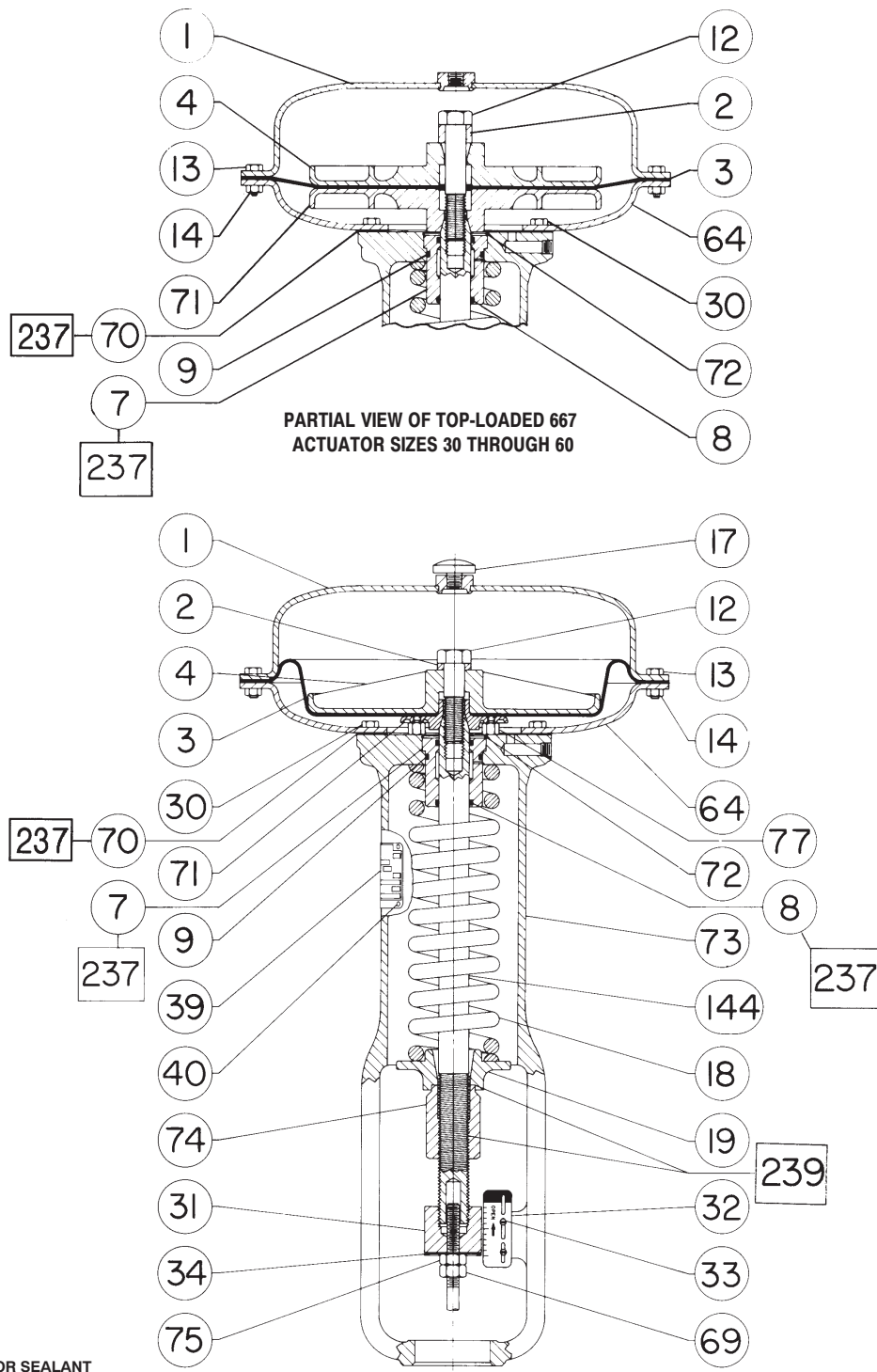

50A8379-C

50A8379-C/IL

Figure 6. Fisher® 667 Actuator Sizes 30 through 60

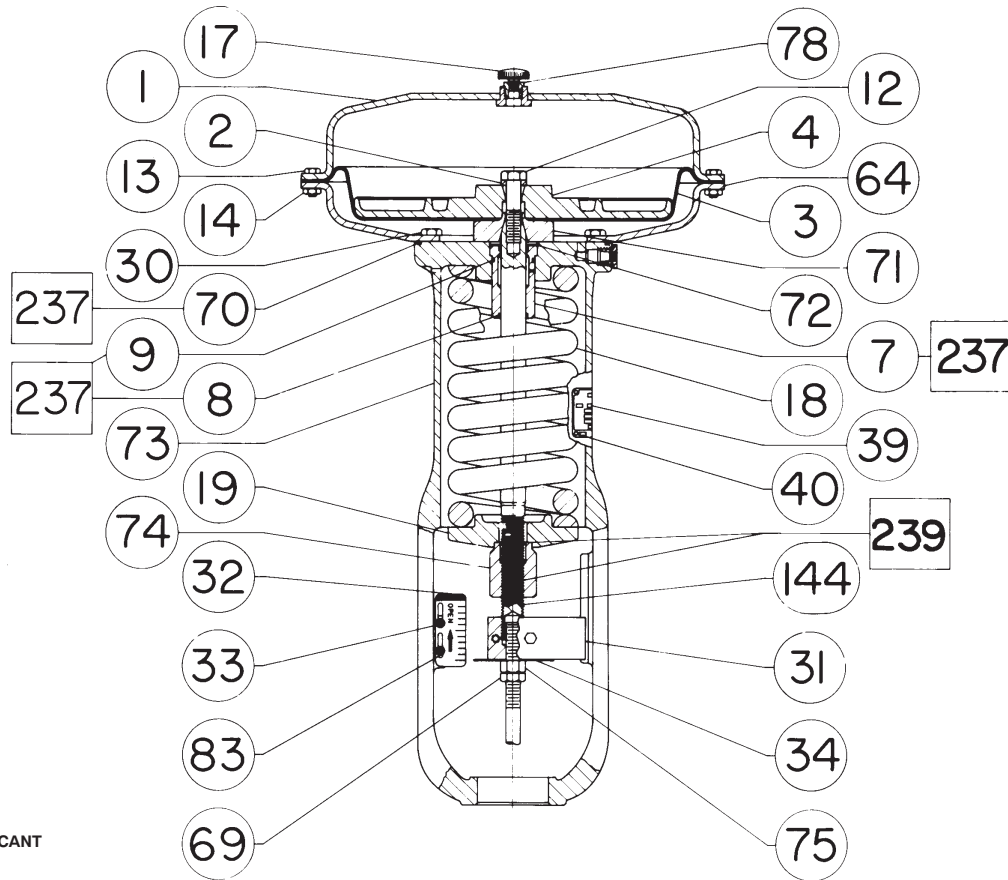

□ APPLY LUBRICANT
50A8598-E/IL

Figure 7. Fisher® 667 Size 70 and 76 Actuator

Key	Description	Part Number	Qty
69	Nut, Hex, Jam		
70*	Gasket Composition [up to 232°C (450°F)] Sizes 30 through 40 Sizes 45 through 60 & 76	1E801204022 1E845404022	1 1
70*	O-Ring Nitrile Size 70 & 87	1D269106992	1
71	Lower Diaphragm Plate		
72	Ring, Snap		
73	Yoke		
74	Spring Adjuster		
75	Nut, Hex		
76	Nut, Speed, Twin		
77	Stop, Travel		
78	Bushing, Pipe, Hex		
79	Screw, Mach, Flat Hd		
81	Screw, Mach, Rd Hd		
82	Indicator, Travel, Adaptor		
83	Washer, Plain		
89	Spring Case Adaptor		
90	Screw, Cap		
102	Plug, Pipe, Hex Hd		

Key	Description	Part Number	Qty
144	Actuator Stem		
227	Washer, Plain		
228	Stem Disk Spacer		
237	Lubricant, lithium grease not furnished with actuator		
239	Lubricant, anti-seize not furnished with actuator		
254	Caution Nameplate		

**Top-Mounted Handwheel
(figures 9, 11, and 12)**

58	Handwheel
60	Retainer Ring
148	Handwheel Body
150	Extension Rod
152	Travel Stop
154	Cap Screw
156	Vent Assembly
157	Guide Plate
158	Mounting Plate

*Recommended spare parts

667 Size 30-76 and 87 Actuators

October 2008

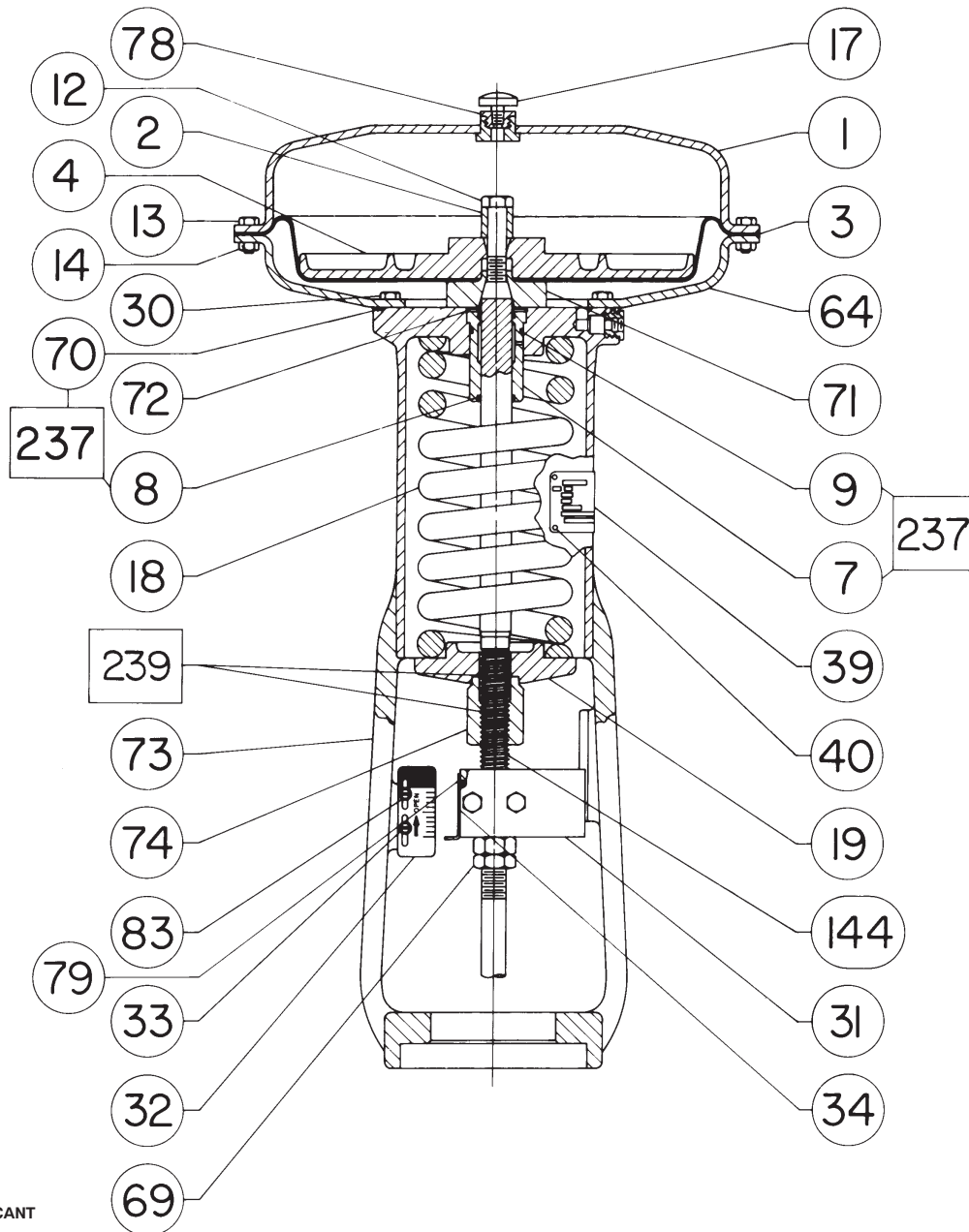
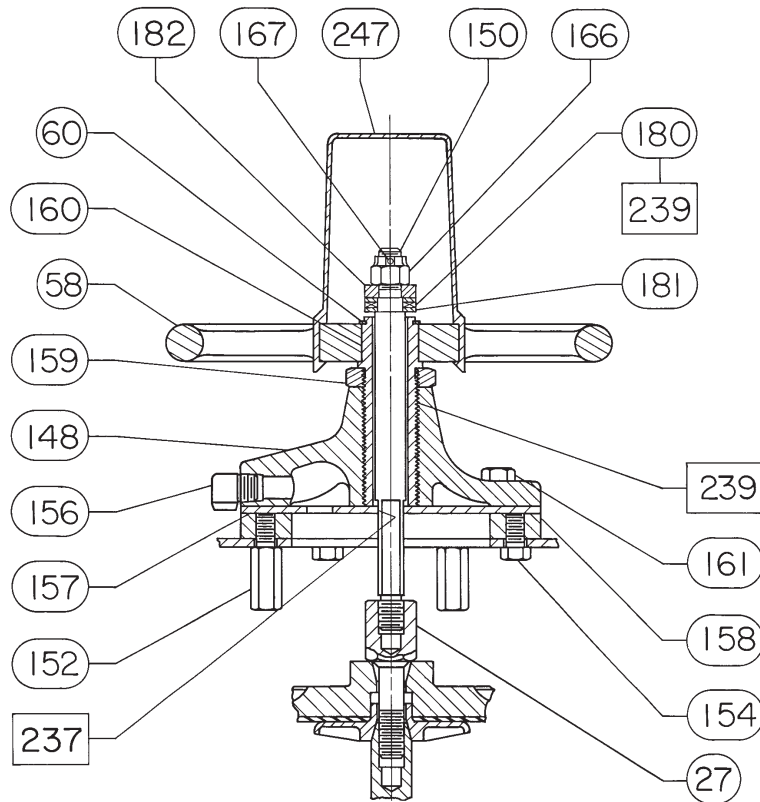

Figure 8. Fisher® 667 Size 87 Actuator

Key	Description	Part Number	Key	Description	Part Number
159	Lock Nut		180	Thrust Bearing	
160	Handwheel Screw		181	Thrust Race	
161	Cap Screw		182	Bearing Retainer	
166	Castle Nut		183	Pipe Nipple	
167	Cotter Pin		239	Lubricant, anti-seize	
178	Machine Screw			not furnished with handwheel	
179	Lockwasher		247	Handwheel Cap	
			253	Spacer, Handjack	



□ APPLY LUBRICANT

NOTE:
THE TOP MOUNTED HANDWHEEL IS NOT DESIGNED FOR USE UNDER
HEAVY LOAD OR FREQUENT USE.

30B3940-C/IL

Figure 9. Top-Mounted Handwheel Assembly for Size 30 through 40 Actuators

**Side-Mounted Handwheel,
Size 34-60 (figures 13 and 14)**

Key	Description	Part Number
51	Handwheel	
54	Hex Jam Nut	
55	Ball	
56	Spring	
132	Operating Nut	
136	Bearing Retainer	
142	Handwheel Body	
143	Mounting Bolts	
144	Hex Nut	
145	Handwheel Screw	
146	Lever & Pin Assembly	
147	Hex Jam Nut	
148	Dowel Pin	
149	Washer	
150	Lockwasher	
151	Bushing	
152	Ball Bearing	
153	Lever Pivot Pin	
154	Retaining Ring	
155	Spacer	
156	Screw	

Key	Description	Part Number
157	Lockwasher	
158	Hex Nut	
159	Pointer Mounting Bolt	
160	Pointer	
161	Machine Screw	
162	Indicator Plate (Aluminum)	
163	Cap Screw	
166	U-Bolt	
167	Guide Bolt	
168	Set Screw	
169	Grease Fitting	
170	Hex Nut	
177	Spring Cap	
178	Machine Screw	
241	Lubricant, lithium grease Not furnished with handwheel	
244	Lubricant, anti-seize Not furnished with handwheel	

**Side-Mounted Handwheel,
Size 70, 76 and 87 (figure 15)**

29	Handgrip	
38	Handgrip Bolt	

667 Size 30-76 and 87 Actuators

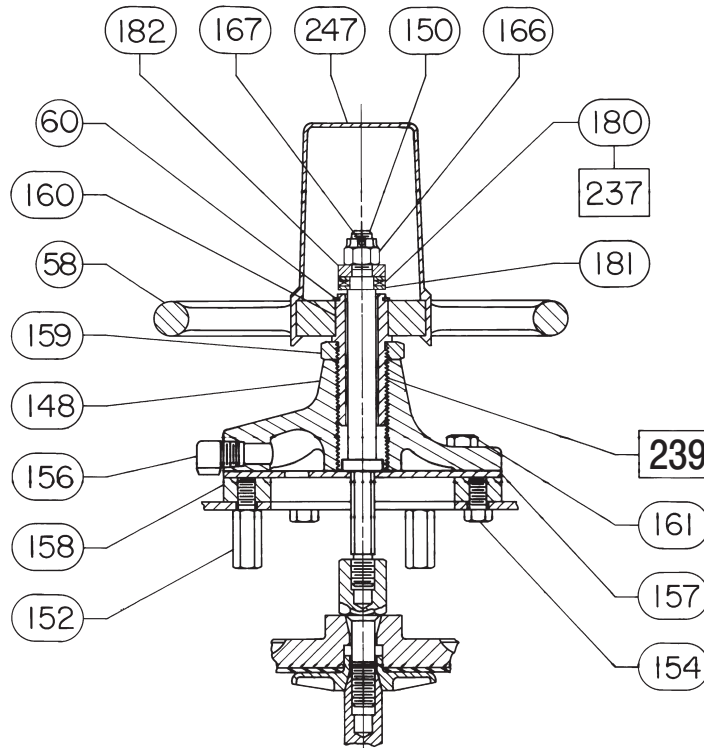

□ APPLY LUBRICANT

30B3942-A

Figure 10. Top-Mounted Handwheel Assembly, Style P2 for Size 45, 50, 60, and 76 Actuators

Key	Description	Part Number	Key	Description	Part Number
44	Worm Gear		58	Handwheel	
45	Bearing Retainer Flange		102	Plug, Pipe	
48	Back Worm Retainer		127	Hex Nut	
49	Front Worm Retainer		148	Travel Stop Body	
50	Ball Bearing		149	Travel Stop Cap	
51	Worm Shaft		150	Extension Rod	
52	Set Screw		150	Travel Stop Stem	
57	Grease Fitting		151	Hex Jam Nut	
58	Handwheel		152	Travel Stop	
87	Cover Band Ass'y		153	Nut, Hex	
89	Spring Case Adaptor		154	Screw, Cap, Hex Hd	
90	Cap Screw		155	Washer, Lock, Split	
121	Set Screw		156	Vent	
122	Key		157	Guide Plate	
123	Lower Sleeve		158	Mounting Plate	
125	Handwheel Indicator		159	Nut, Travel Stop	
127	Handwheel Cap		160	Screw, Handwheel	
128	Needle Bearing		161	Screw, Cap, Hex Hd	
129	Needle Bearing Race		162	Washer	
130	Roll Pin		177	Travel Stop Screw	
131	Spring Adjusting Screw		184	Nipple, Pipe, NPT	
132	Needle Bearing		237	Lubricant, lithium grease	
133	Needle Bearing Race		239	Lubricant, anti-seize	
141	Ball		247	Travel Stop Cap	
142	Spring		248	Mounting Plate	
237	Lubricant, lithium grease Not Furnished with Handwheel				
239	Lubricant, anti-seize Not Furnished with Handwheel				
245	Yoke Extension				

Casing-Mounted Travel Stops (figures 16 through 20)

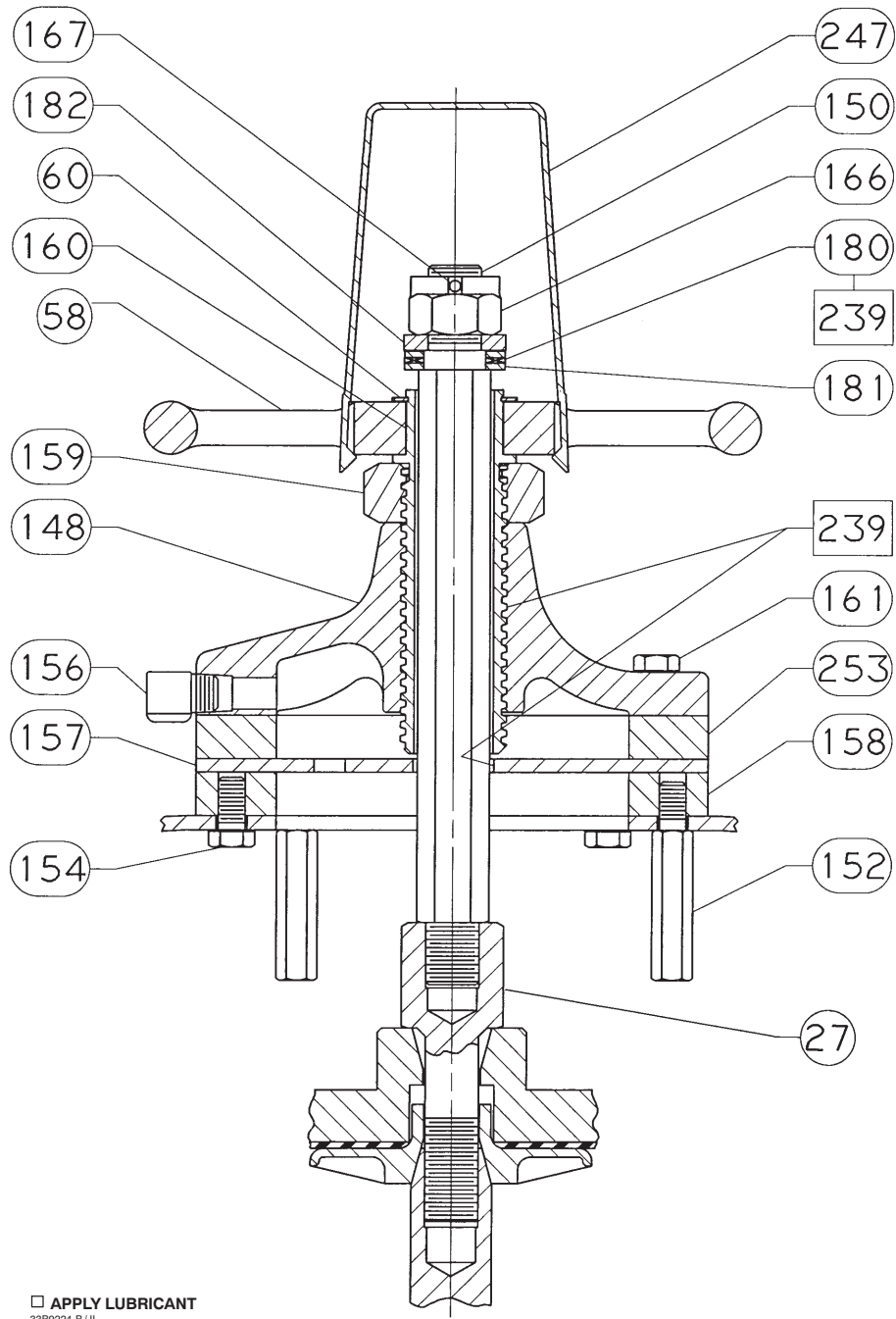

Figure 11. Top-Mounted Handwheel Assembly for Size 45-76 Actuators

667 Size 30-76 and 87 Actuators

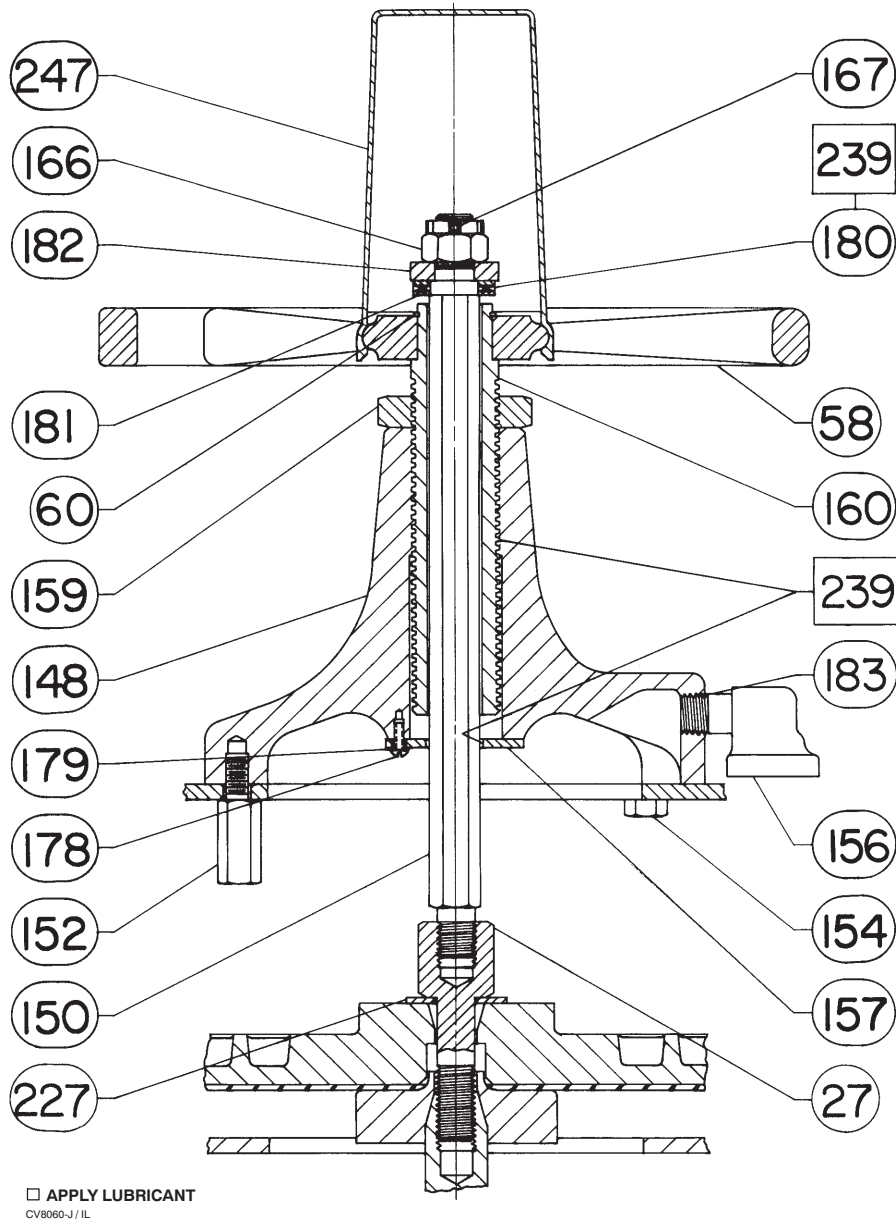
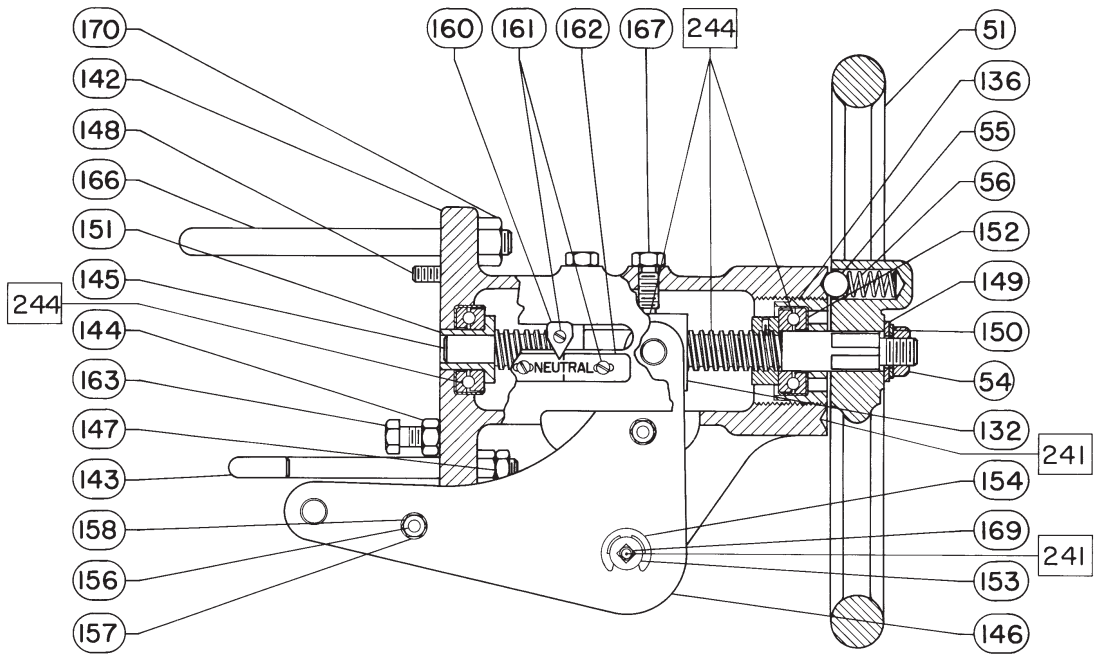
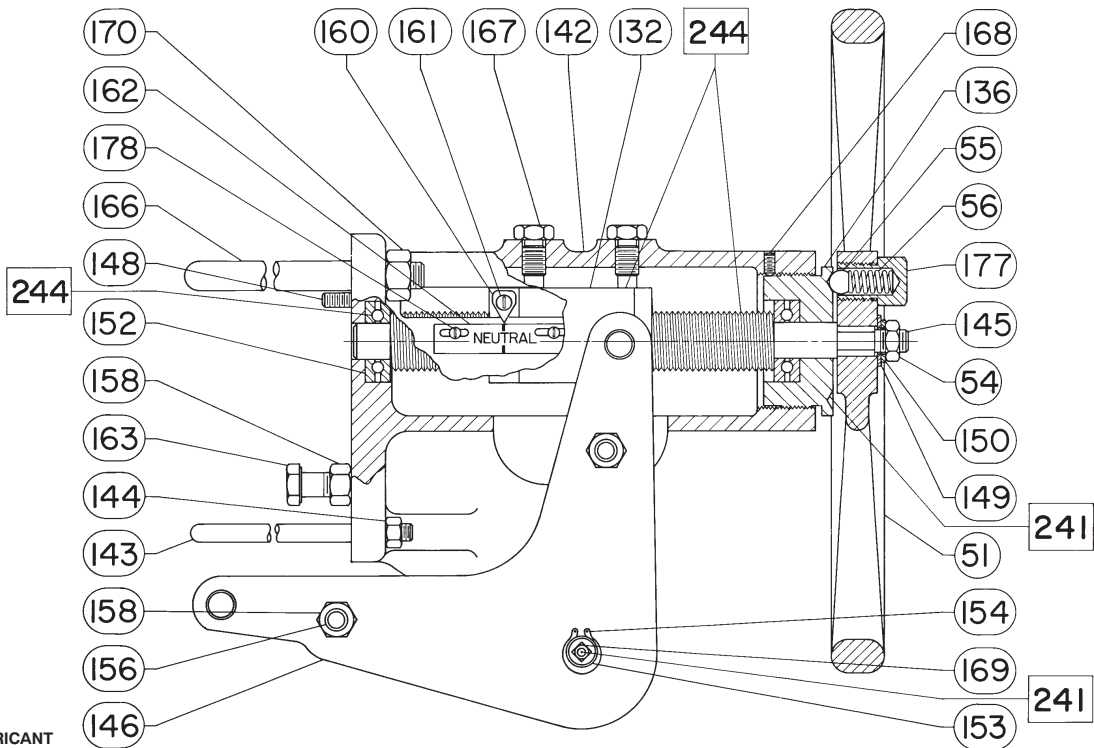

Figure 12. Top-Mounted Handwheel Assembly for Size 70 and 87 Actuators



□ APPLY LUBRICANT
30A8778-D/IL

Figure 13. Side Mounted Handwheel Assembly for Size 34 and 40 Actuators



□ APPLY LUBRICANT
40A8779-D/IL

Figure 14. Side-Mounted Handwheel Assembly for Size 45 through 60 Actuators

667 Size 30-76 and 87 Actuators

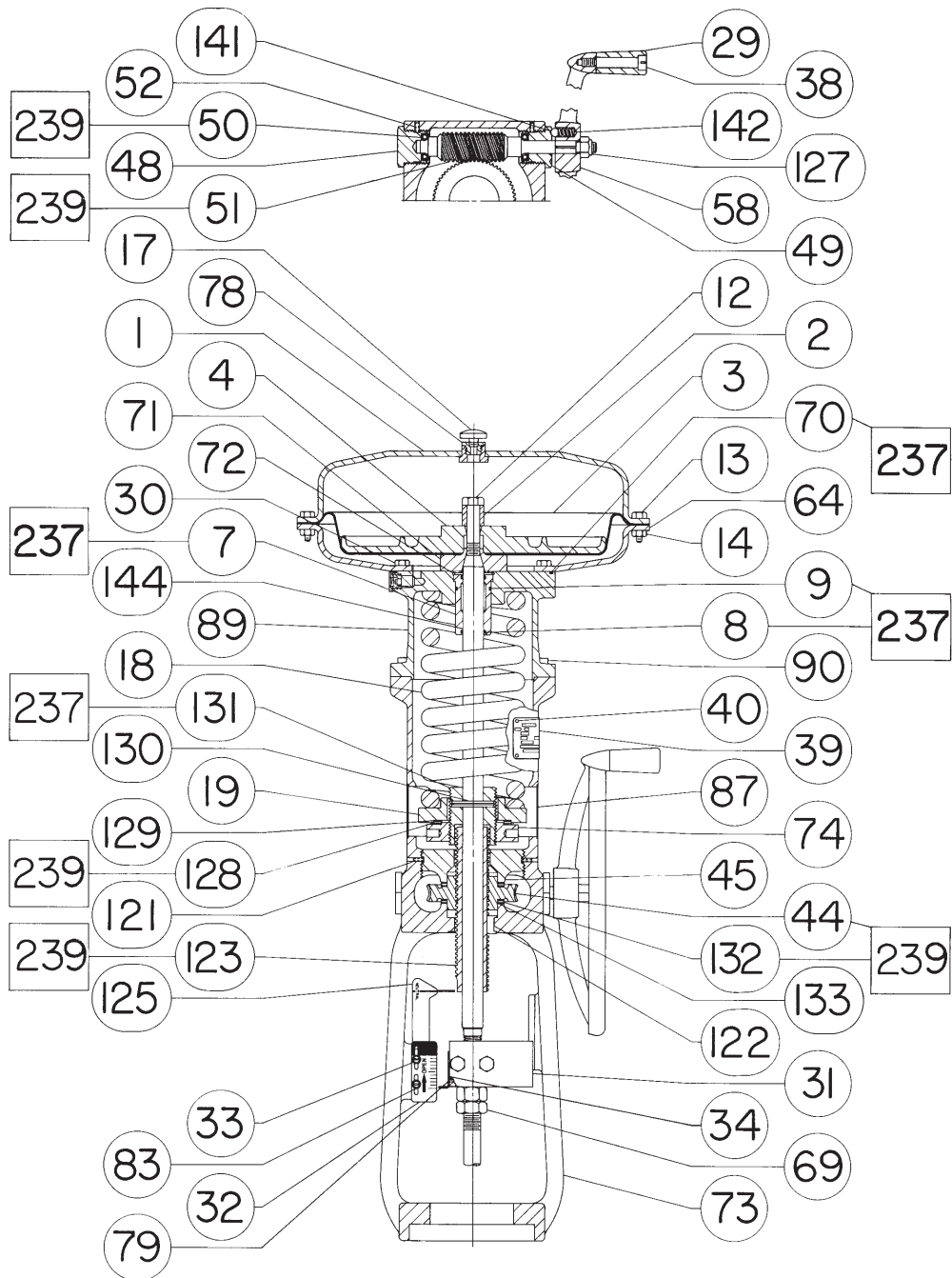

PART NOT SHOWN: 57
 APPLY LUBRICANT
 E0871/IL

Figure 15. Size 70, 76, and 87 Actuator with Side Mounted Handwheel Assembly

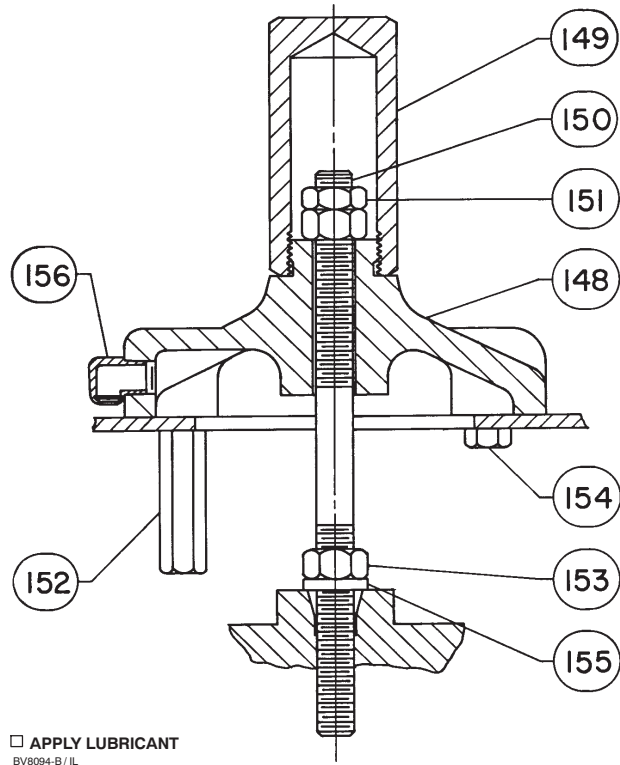

□ APPLY LUBRICANT
BV8094-B/IL

Figure 16. Style 10 Down Travel Stop (Casing Mounted)

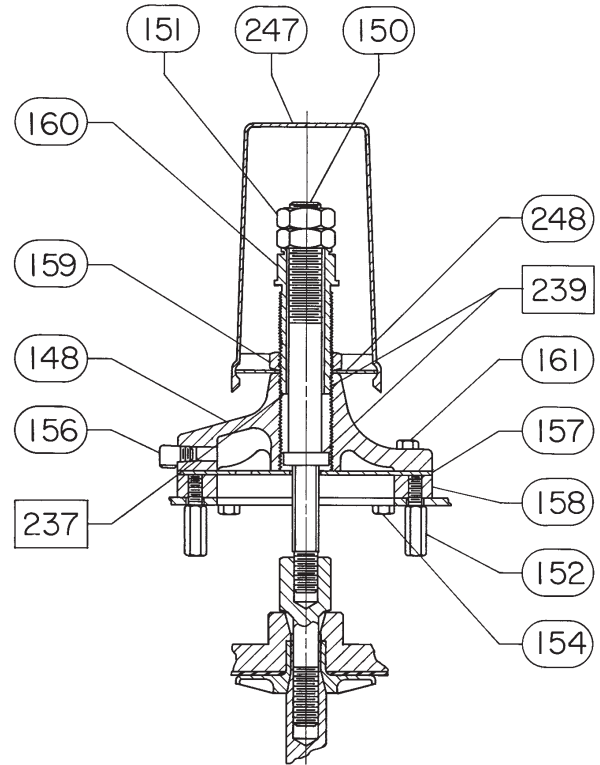

□ APPLY LUBRICANT
3BA1212-B/IL

Figure 17. Style 11 Up Or Down Travel Stop (Casing Mounted)

667 Size 30-76 and 87 Actuators

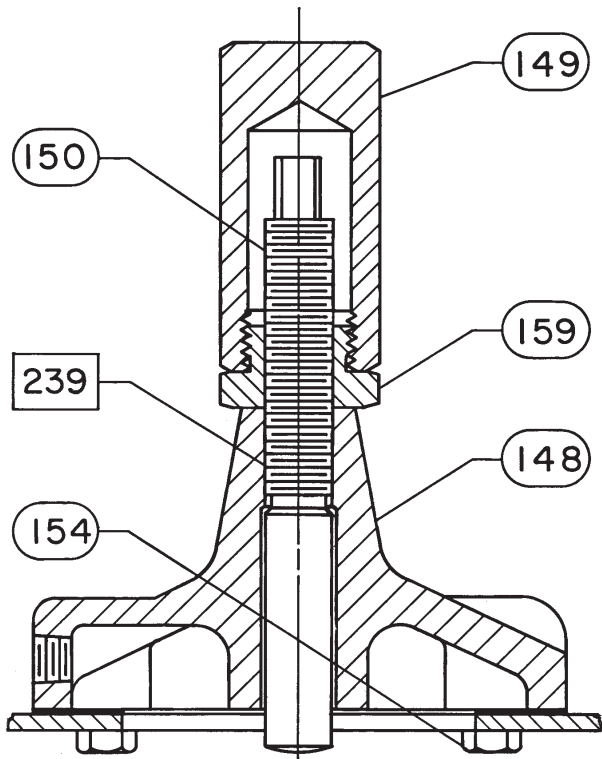

□ APPLY LUBRICANT
28A1208-B/IL

Figure 18. Style 12 Up Travel Stop (Casing Mounted)

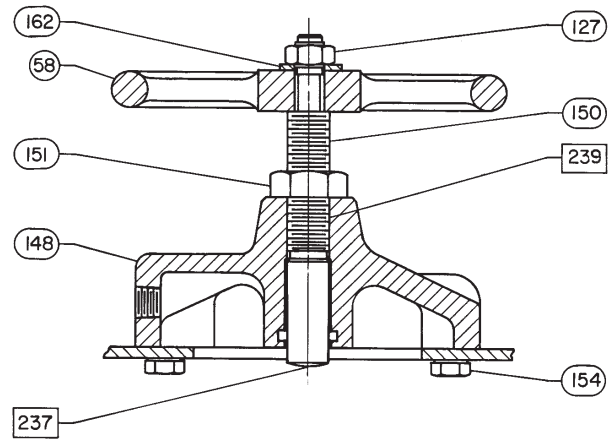

□ APPLY LUBRICANT
28A1204-B/IL

Figure 19. Style 13 Up Travel Stop (Casing Mounted), size 30 shown

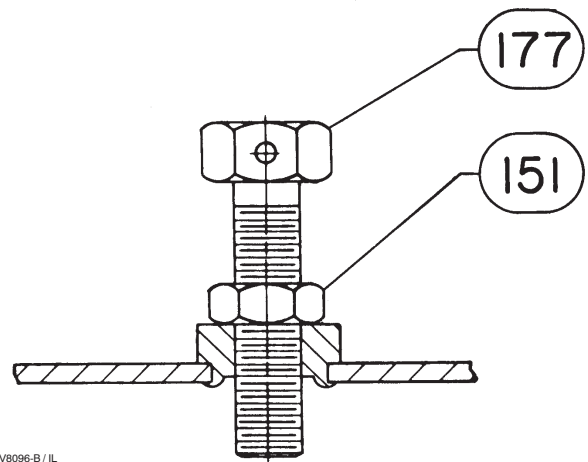

AV8096-B/IL

Figure 20. Style 14 Up Travel Stop (Casing Mounted)

667 Size 30-76 and 87 Actuators

Fisher and easy-e are marks owned by one of the companies in the Emerson Process Management business division of Emerson Electric Co. Emerson Process Management, Emerson, and the Emerson logo are trademarks and service marks of Emerson Electric Co. All other marks are the property of their respective owners.

The contents of this publication are presented for informational purposes only, and while every effort has been made to ensure their accuracy, they are not to be construed as warranties or guarantees, express or implied, regarding the products or services described herein or their use or applicability. All sales are governed by our terms and conditions, which are available upon request. We reserve the right to modify or improve the designs or specifications of such products at any time without notice. Neither Emerson, Emerson Process Management, nor any of their affiliated entities assumes responsibility for the selection, use or maintenance of any product. Responsibility for proper selection, use, and maintenance of any product remains solely with the purchaser and end-user.

Emerson Process Management

Marshalltown, Iowa 50158 USA
Sorocaba, 18087 Brazil
Chatham, Kent ME4 4QZ UK
Dubai, United Arab Emirates
Singapore 128461 Singapore
www.Fisher.com

