



Crosby's Series 800 adjustable blowdown and Series 900 fixed blowdown OMNI-TRIM® full nozzle pressure relief valves have a simplified, single trim design with superior application versatility.

Features

- Relieving capacities certified by National Board of Boiler and Pressure Vessel Inspectors. Certification includes air and steam for Series 800, and air, steam and water for Series 900.
- Valves manufactured in accordance with the requirements of ASME Boiler and Pressure Vessel Code Section VIII and Section III.
- Superior seat tightness. Precision lapped flat metal-to-metal seats, or elastomer or TFE O-ring soft seats provide the ultimate in seat tightness.
- Maximum corrosion resistance. Trim components are stainless steel as standard. All 316 stainless steel, Monel®, Hastelloy® and NACE* optional constructions are available.
- Spring standardization. Standard Series 800 and Series 900 OMNI-TRIM® pressure relief valves are suitable for inlet temperatures to 750°F [399°C], using a 17-7PH stainless steel spring.
- Positive built-in lift stop.
- Fewer parts result in increased reliability and ease of maintenance.
- Series 800 pressure relief valves have an external blowdown adjustment allowing for short blowdown, smaller differential between operating and set pressures, and reduced product loss.
- Series 900 OMNI-TRIM® valves use a single trim design for liquid, gas and vapor services.
- Series 900 OMNI-TRIM® valves provide reliable blowdown without the need for adjustment.

* Contact the factory for compliance to NACE MR-0175-2003 or later requirements.

OMNI-TRIM® and Crosby are registered trademarks of Tyco International Services AG or its affiliates in the United States and/or other countries. All other brand names, product names, or trademarks belong to their respective holders.



Table of Contents

Introduction and Description 2 - 3

Style Designation — How to Order Series 800 4

Style Designation — How to Order Series 900 5

Materials of Construction — Series 800 6

Materials of Construction — Series 900 7

Caps and Lifting Levers 8

O-ring Seat Materials with Pressure and Temperature Limits 9

Specifications — Series 800

Threaded and Flanged Connections (USCS Units) 10-11

Threaded and Flanged Connections [Metric Units] 12-13

Specifications — Series 900

Threaded and Flanged Connections (USCS Units) 14-15

Threaded and Flanged Connections [Metric Units] 16-17

Capacity Tables — Air, Steam and Water

USCS Units 18-20

Metric Units 21-23

Configurations 24



Series 800 and Series 900 Pressure Relief Valves

Crosby's Series 800 adjustable and Series 900 OMNI-TRIM® full nozzle pressure relief valves have a simplified, single trim design with superior application versatility. They provide overpressure protection for medium flow applications in refineries, chemical and petrochemical plants, power plant auxiliary systems, and pulp and paper mills. The Series 800/900 valves have been used successfully in thousands of industrial process applications since their inception in 1990.

Series 800 pressure relief valves are designed for use on air, gas, vapor and steam service. External precise blowdown adjustments provide shorter blowdown than the Series 900, typically in the range of 5 to 15 percent. Increased efficiency results from this improved performance since system pressure can operate closer to the set pressure. The shorter blowdown also reduces product loss.

Series 900 OMNI-TRIM® pressure relief valves provide overpressure protection on air, gas, vapor, liquid, thermal relief and steam service. Maximum fixed blowdown is set at the factory, typically 20% or less. Standardization of components in the OMNI-TRIM® design provides easy assembly, durability, and less repair, maintenance and inventory costs than with valves having varying internals materials. Series 900 can also be manufactured to ASME Code Section III for nuclear-related applications.

Introduction

Crosby Series 800 adjustable and Series 900 OMNI-TRIM® are reliable pressure relief valves for industrial applications. Their design and options provide maximum versatility and premium performance.

Effective orifice areas are 0.074 (Series 900 only), 0.110, 0.196, 0.307 and 0.503 sq. in. [47.7, 71.0, 126, 198 and 325 sq. mm]. The Series 900 is also available with a 0.049 sq. in. effective orifice area for liquid service applications only. Consult Crosby for additional information. Standard materials of construction are carbon steel cylinder; 316 stainless steel base, disc insert, disc holder and guide; and 17-7PH stainless steel spring. The Series 800 adjusting ring, set screw and gasket are also 316 stainless steel as standard.

Optional materials of construction are available for special applications such as cryogenic service or conditions involving corrosive fluids. In addition, optional materials are available conforming to NACE MR-0175¹. Special cleanings, coatings and lubricants are also available on application.

For applications at pressures and temperatures not listed in this catalog, consult Crosby.

ASME Code Requirements

Series 800 and Series 900 pressure relief valves are manufactured in accordance with requirements of ASME Boiler and Pressure Vessel Code, Section VIII. Also available is a Series 900 valve complying to the requirements of ASME Boiler and Pressure Vessel Code, Section III.

Certified Capacities

Capacity certification includes air and steam for Series 800, and air, steam and water for Series 900. Relieving capacities are certified by National Board of Boiler and Pressure Vessel Inspectors.

Seat Design

Series 800 and Series 900 pressure relief valves are available with flat metal-to-metal or elastomer or TFE O-ring soft seats for optimum seat tightness and minimal maintenance. Details on O-ring materials and pressure/temperature limitations are on page 9. All O-rings are standard commercial sizes.

Blowdown

Blowdown is the difference between the opening and reseating pressure of a pressure relief valve expressed as a percentage of set pressure. Series 900 blowdown is fixed and non-adjustable (typically less than 20%) on liquid, gas and vapor applications.

Series 800 blowdown is adjustable with a typical adjustable range of 5 to 15 percent. Each valve is shipped with a factory ring setting which will provide a nominal blowdown of 10%, unless specified otherwise.

Notes

1. Contact the factory for compliance to NACE MR-0175-2003 or later requirements.
2. Monel® is a registered trademark of International Nickel Company, Inc.
3. Hastelloy® is a registered trademark of Haynes International, Inc.

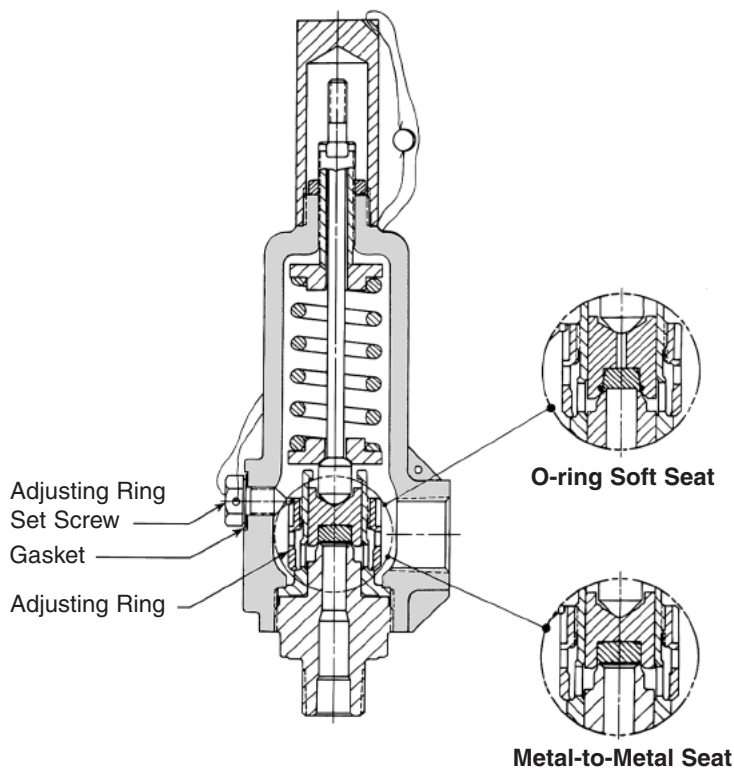

Series 800 Adjustable Blowdown Pressure Relief Valve

Series 800 and Series 900 Pressure Relief Valves

Optional Connections

Series 800 pressure relief valves with orifice areas of 0.110 and 0.196 sq. in. [71.0 and 126 sq. mm] may be furnished with welded connections or with flanged connections. For 0.307 and 0.503 sq. in. [198 and 325 sq. mm] orifice valves with flanged connections, please refer to the JOS-E, JBS-E and JLT-E Style catalog.

Series 900 OMNI-TRIM® valves may be furnished with optional flanged or welded connections in all sizes. Standard flanged connections are lap joint stub end construction.

Series 800 and Series 900 OMNI-TRIM® valves may be furnished with optional flanged connections with unique face-to-face dimensions to match existing installations. Additionally, oversized or expanded outlet sizes are available in selected orifices for flashing service applications. Consult Crosby for availability of these special designs.

In installations where a Bolted Cylinder is preferred for maintenance and repair reasons, a special version of Series 900 No. 5 orifice in 3/4" x 1" connection size only is available. This valve is designated as 9511019A and has a maximum set pressure of 1500 psig [103 barg]. See illustration above. Standard connections are 3/4" x 1" MNPT x FNPT. For optional flange connections, consult Crosby.

General applications

- Air
- Gas
- Vapor
- Steam
- Liquid (Series 900)
- Thermal relief (Series 900)

Technical data

Series 800

Temperature range: -450°F to +750°F
[-268°C to +399°C]

Pressure limits: 1500 psig [103.4 barg]
Steam: 1000 psig [68.9 barg]

Sizes: 3/4" x 1" to 2" x 2" and 1 1/2" x 2 1/2"

Series 900

Temperature range: -450°F to +750°F
[-268°C to +399°C]

Pressure limits: 5000 psig [344 barg]
Steam: 1000 psig [68.9 barg]

Sizes: 1/2" x 1" to 2" x 2" and 1 1/2" x 2 1/2"

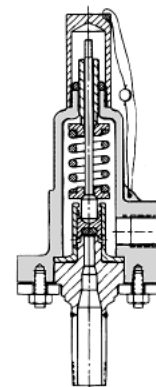

Series 900 Bolted Cylinder

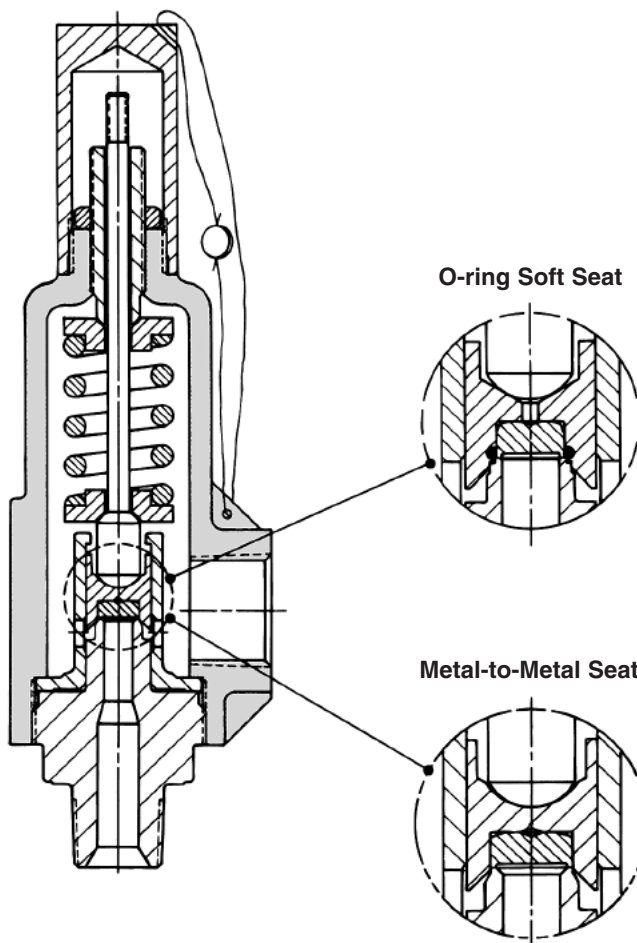

Series 900 Fixed Blowdown OMNI-TRIM® Pressure Relief Valve

Series 800 Style Designation

1st Digit	2nd Digit	3rd Digit	4th Digit	5th Digit	6th Digit	7th Digit	8th Digit
Series	Effective Orifice Area	Maximum Set Pressure¹	Seat Material⁶	Materials of Construction^{2,7}	Connection Size - NPS³	Connection Type^{3,4,5}	Caps and Lifting Levers
8 - Series 800 Adjustable Blowdown Relief Valve	6 - 0.110 sq. in. [71.0 sq. mm] 7 - 0.196 sq. in. [126 sq. mm] 8 - 0.307 sq. in. [198 sq. mm] 9 - 0.503 sq. in. [325 sq. mm]	1 - 1500 psig [103 barg]	1 - Metal 2 - BUNA-N 3 - Viton®* 4 - Ethylene Propylene Rubber (EPR) 5 - Kalrez®** 6 - TFE 7 - Other (Specify)	0 - Standard Materials Carbon Steel Cylinder 316 SS Base, Disc Insert, Disc Holder, Guide and Adj. Ring 17-7PH SS Spring -50°F to +750°F [-45.5°C to +398°C] 1 - All 316 SS Materials -450°F to +500°F [-267°C to +260°C] 2 - All 316 SS Materials Inconel® X750 Spring -450°F to +750°F [-267°C to +398°C] 3 - Carbon Steel Cylinder Monel® Base, Disc Insert, Disc Holder, Guide and Adj. Ring Note ⁵ Inconel® X750 Spring -50°F to +750°F [-45.5°C to +398°C] 4 - All Monel® Materials Inconel® X750 Spring Note ⁵ -320°F to +750°F [-195°C to +398°C] 7 - NACE MR-0175-2002 ⁹ Carbon Steel Cylinder 316 SS Base, Disc Insert, Disc Holder, Guide and Adj. Ring Inconel® X750 Spring With 316 SS Washers -50°F to +750°F [-45.5°C to +398°C] 8 - Other (Specify)	1 - 3/4 x 1 2 - 1 x 1 3 - 1 x 1 1/2 4 - 1 1/2 x 1 1/2 5 - 1 1/2 x 2 6 - 2 x 2 7 - 1 1/2 x 2 1/2	M - MNPT x FNPT F - FNPT x FNPT 1 - 150# RF x 150# RF 2 - 300# RF x 150# RF 3 - 600# RF x 150# RF 7 - Other (Specify) 8 - Male SW x Male SW ⁸	A - Standard Threaded Cap B - Threaded Cap with Test Rod D - Packed Lifting Lever E - Packed Lifting Lever with Test Rod

*Reg. U.S. Pat. Office for Du Pont's fluoroelastomer.

**Reg. U.S. Pat. Office for Du Pont's perfluoroelastomer parts.

How to Order

Example 1: To specify a 3/4 x 1 MNPT x FNPT Series 800 valve with a 0.110 sq. in. [70.96 sq. mm] effective area, BUNA-N seats, all 316 stainless steel materials, standard threaded cap, process fluid operating temperature at 150°F [66°C], and set at 175 psig [12.07 barg], use the following style designation: **861211MA**

Example 2: To specify a 1 1/2 x 2 MNPT x FNPT Series 800 valve with a 0.307 sq. in. [198.0 sq. mm] effective area, metal seats, standard materials, packed lifting lever with test rod, for saturated steam service set at 200 psig [13.79 barg], use the following style designation: **881105ME-STM**

Caution!

Refer to Pages 10-13 to verify the Series 800 model specified is available in the orifice, connection size and connection type combination selected.

Notes

- Maximum set pressure for steam service is 1000 psig [68.95 barg].
- For steam service a copper-nickel alloy disc holder and guide is used. Add — STM after style designation.
- Optional flanged connections are available for Nos. 6 and 7 orifices only. For Nos. 8 and 9 orifice valves with flanged connections, please refer to the JOS-E, JBS-E and JLT-E Style catalog.
- Optional flange facings (such as ring type joint, 125-200RA), if required, must always be specified.
- Optional flange materials (such as Monel®), if required, must always be specified.
- Refer to page 9 for soft seat pressure and temperature limits.
- See page 6 for complete listing of materials of construction.
- Not available with soft seats, contact factory.
- Contact factory for compliance to NACE MR-0175-2003 or later requirements.

Series 900 OMNI-TRIM® Style Designation

1st Digit	2nd Digit	3rd Digit	4th Digit	5th Digit	6th Digit	7th Digit	8th Digit
Series	Effective Orifice Area	Maximum Set Pressure^{2,6}	Seat Material⁶	Materials of Construction^{1,3}	Connection Size - NPS⁷	Connection Type^{4,5,8}	Caps and Levers
9 - Series 900 Fixed Blowdown Relief Valve	5 - 0.074 sq. in. [47.74 sq. mm] 6 - 0.110 sq. in. [70.96 sq. mm] 7 - 0.196 sq. in. [126.4 sq. mm] 8 - 0.307 sq. in. [198.0 sq. mm] 9 - 0.503 sq. in. [324.5 sq. mm]	1 - 1500 psig [103.42 barg] 2 - 2500 psig [172.36 barg] 5 - 5000 psig [344.74 barg]	1 - Metal 2 - BUNA-N 3 - Viton® 4 - Ethylene Propylene Rubber (EPR) 5 - Kalrez® 6 - TFE 7 - Other (Specify)	0 - Standard Materials Carbon Steel Cylinder 316 SS Base, Disc Insert, Disc Holder and Guide 17-7PH SS Spring -50°F to +750°F [-45.6°C to +399°C] 1 - All 316 SS Materials -450°F to +500°F [-268°C to +260°C] 2 - All 316 SS Materials Inconel® X750 Spring -450°F to +750°F [-268°C to +399°C] 3 - Carbon Steel Cylinder Monel® Base, Disc Insert, Disc Holder and Guide Inconel® X750 Spring Note ⁵ -50°F to +750°F [-45.6°C to +399°C] 4 - All Monel® Materials Inconel® X750 Spring Note ⁵ -320°F to +750°F [-196°C to +399°C] 5 - Carbon Steel Cylinder Hastelloy®C Base, Disc Insert, Disc Holder and Guide Inconel® X750 Spring Note ⁵ -50°F to +750°F [-45.6°C to +399°C] 6 - All Hastelloy®C Materials Note ⁵ -320°F to +750°F [-196°C to +399°C] 7 - NACE MR-0175-2002 ¹⁰ Carbon Steel Cylinder 316 SS Base, Disc Insert, Disc Holder & Guide Inconel® X750 Spring With 316 SS Washers -50°F to +750°F [-45.6°C to +399°C] 8 - Other (Specify)	0 - 1/2 x 1 1 - 3/4 x 1 2 - 1 x 1 3 - 1 x 1 1/2 4 - 1 1/2 x 1 1/2 5 - 1 1/2 x 2 6 - 2 x 2 7 - 1 1/2 x 2 1/2 9 - Other	M - MNPT x FNPT F - FNPT x FNPT 1 - 150# RF x 150# RF 2 - 300# RF x 150# RF 3 - 600# RF x 150# RF 4 - 1500# RF x 300# RF 5 - 2500# RF x 300# RF 7 - Other (Specify) 8 - Male SW x Male SW ⁹ 9 - MNPT x FNPT 3/4 x 1 Bolted Cylinder (951 Orifice only)	A - Standard Threaded Cap B - Threaded Cap with Test Rod D - Packed Lifting Lever E - Packed Lifting Lever with Test Rod

Available Options

- Special materials not catalogued such as Alloy 20, Titanium, etc.
- Tri-clamp sanitary connections.
- 0.049 sq. in. effective orifice area for liquid service.
- O-ring seat materials not catalogued.
- Position indicators, proximity switches, etc.

Notes

1. For steam service a 17-4PH disc holder is used. Add — STM after style designation.
2. Maximum set pressure for steam service is 1000 psig [68.95 barg].
3. See page 7 for complete listing of materials of construction.
4. Optional flange facings (such as ring type joint, 125-200RA), if required, must always be specified.
5. Optional flange materials (such as Monel® and Hastelloy®), if required, must always be specified.
6. See pages 14 - 17 for appropriate maximum set pressures.
7. See pages 14 - 17 for appropriate inlet and outlet sizes for each effective orifice area.
8. Consult Crosby for materials, and center to face and height dimensions for socket weld (SW) connections. Weights are the same as for threaded connections.
9. Not available with soft seats; contact the factory.
10. Contact factory for compliance to NACE MR-0175-2003 or later requirements.

How to Order

Example 1: To specify a 3/4 x 1 MNPT x FNPT Series 900 valve with a 0.074 sq. in. [47.74 sq. mm] effective area, BUNA-N seats, all 316 stainless steel materials, standard threaded cap, process fluid operating temperature at 150°F [66°C], and set at 175 psig [12.07 barg], use the following style designation: **951211MA**

Example 2: To specify a 1 1/2 x 2 MNPT x FNPT Series 900 valve with a 0.307 sq. in. [198.0 sq. mm] effective area, metal seats, standard materials, packed lifting lever with test rod, for saturated steam service set at 200 psig [13.79 barg], use the following style designation: **981105ME-STM**

Caution!
Refer to Pages 14-17 to verify the Series 900 model number specified is available in the orifice, connection size and connection type combination selected.

Valve Materials Series 800 Relief Valves

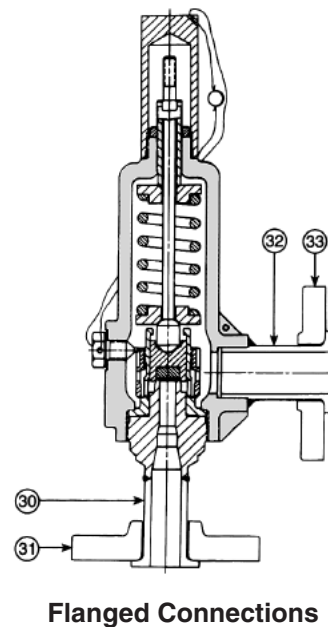
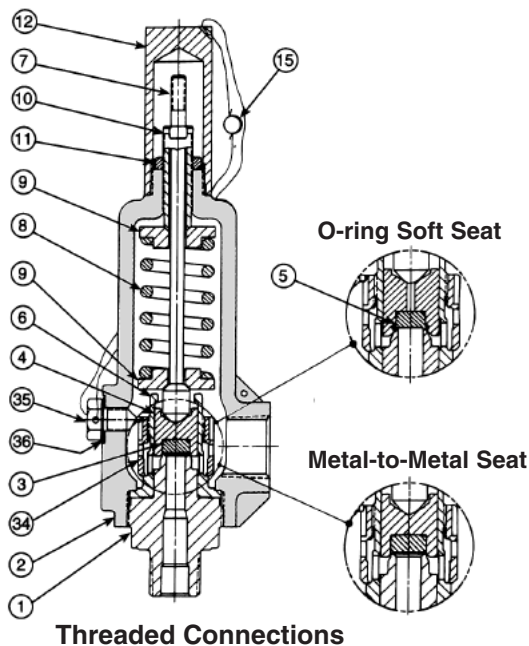

Materials of Construction

Material Designation→		Standard Materials	Variations from Standard Materials				
Part No.	Part Name	(0)	(1)	(2)	(3)	(4)	(7)
		-50°F to +750°F [-45.6°C to +399°C]	-450°F to +500°F [-268°C to +260°C]	-450°F to +750°F [-268°C to +399°C]	-50°F to +750°F [-45.6°C to +399°C]	-320°F to +750°F [-196°C to +399°C]	NACE MR0175-2002 Level II -50°F to +750°F [-45.6°C to +399°C]
1	Base	316 SS	316 SS	316 SS	Monel®	Monel®	316 SS
2	Cylinder	Carbon Steel SA-216 Gr. WCB	316 SS SA-351 Gr. CF8M	316 SS SA-351 Gr. CF8M	Carbon Steel SA-216 Gr. WCB	Monel® ⁷ ASTM A 494 Gr. M35-1	Carbon Steel SA-216 Gr. WCB
3	Disc Insert ³	316 SS	316 SS	316 SS	Monel®	Monel®	316 SS
4	Disc Holder	316 SS ⁷	316 SS ⁷	316 SS ⁷	Monel®	Monel®	316 SS ⁷
5	O-ring ^{2,3}	Specify	Specify	Specify	Specify	Specify	Specify
6	Guide	316 SS ⁷	316 SS ⁷	316 SS ⁷	Monel®	Monel®	316 SS ⁷
7	Spindle	416 SS	316 SS	316 SS	416 SS	Monel®	316 SS
8	Spring	17-7PH SS	316 SS	Inconel® X750	Inconel® X750	Inconel® X750	Inconel® X750
9	Spring Washers	416 SS	316 SS	316 SS	316 SS	Monel®	316 SS
10	Adjusting Bolt	416 SS	316 SS	316 SS	416 SS	Monel®	316 SS
11	Adjusting Bolt Nut	Carbon Steel	316 SS	316 SS	Carbon Steel	Monel®	316 SS
12	Type A Cap ⁵	Carbon Steel	316 SS	316 SS	Carbon Steel	Monel®	Carbon Steel
13	Nameplate ⁴	300 Series SS	300 Series SS	300 Series SS	300 Series SS	300 Series SS	300 Series SS
14	Drive Screws ⁴	SS	SS	SS	SS	SS	SS
15	Seal & Wire	Lead & SS	Lead & SS	Lead & SS	Lead & SS	Lead & SS	Lead & SS
30	Lap Joint Stub End (Inlet)	316 SS	316 SS	316 SS	Monel®	Monel®	316 SS
31	Inlet Flange	Carbon Steel ⁶	316 SS	316 SS	Carbon Steel ⁶	Carbon Steel ⁶	Carbon Steel ⁶
32	Lap Joint Stub End (Outlet)	Carbon Steel ⁶	316 SS	316 SS	Carbon Steel ⁶	Monel®	Carbon Steel ⁶
33	Outlet Flange	Carbon Steel ⁶	316 SS	316 SS	Carbon Steel ⁶	Carbon Steel ⁶	Carbon Steel ⁶
34	Adjusting Ring	316 SS	316 SS	316 SS	Monel®	Monel®	316 SS
35	Set Screw	316 SS	316 SS	316 SS	Monel®	Monel®	316 SS
36	Set Screw Gasket ³	316 SS	316 SS	316 SS	316 SS	Monel®	316 SS

Note: Blue shaded materials indicate variation from standard.

Notes

- Material is copper-nickel alloy for steam applications.
- Refer to page 9 for pressure/temperature limits and available O-ring materials.
- Recommended spare part.
- Not shown.
- Refer to page 8 for other available cap styles and materials.
- Low temperature limit for carbon steel flanges is -20°F [-28.9°C]. Use 316 SS below -20°F.**
- ASME Code Case 1750-17.
- Styles 8611 () -STM spindle furnished as spindle and spindle ball sub-assembly.
- A nickel/graphite based lubricant/sealant is used on threads, sealing and bearing surfaces.
- Inconel® is a registered trademark of International Nickel Company, Inc.

Valve Materials Series 900 OMNI-TRIM® Valves

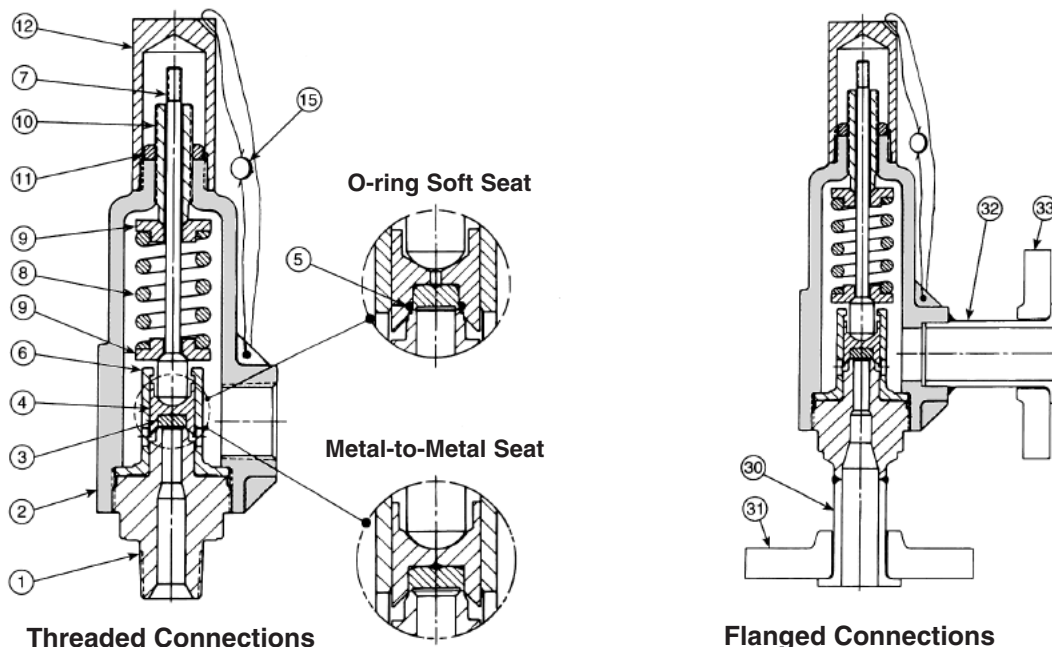

Materials of Construction									
		Standard Materials			Variations from Standard Materials				
Material Designation→	(0)	(1)	(2)	(3)	(4)	(5)	(6)	(7)	NACE MR0175-2002 Level II
Part No.	Part Name	-50°F to +750°F [-45.6°C to +399°C]	-450°F to +500°F [-268°C to +260°C]	-450°F to +750°F [-268°C to +399°C]	-50°F to +750°F [-45.6°C to +399°C]	-320°F to +750°F [-196°C to +399°C]	-50°F to +750°F [-45.6°C to +399°C]	-320°F to +750°F [-196°C to +399°C]	-50°F to +750°F [-45.6°C to +399°C]
1	Base	316 SS	316 SS	316 SS	Monel®	Monel®	Hastelloy® C	Hastelloy® C	316 SS
2	Cylinder	Carbon Steel SA-216 Gr. WCB	316 SS SA-351 Gr. CF8M	316 SS SA-351 Gr. CF8M	Carbon Steel SA-216 Gr. WCB	Monel® ⁷ ASTM A 494 Gr. M35-1	Carbon Steel SA-216 Gr. WCB	Hastelloy® C SA-494 Gr. CW-12MW	Carbon Steel SA-216 Gr. WCB
3	Disc Insert ²	316 SS	316 SS	316 SS	Monel®	Monel®	Hastelloy® C	Hastelloy® C	316 SS
4	Disc Holder	316 SS ¹	316 SS ¹	316 SS ¹	Monel®	Monel®	Hastelloy® C	Hastelloy® C	316 SS ¹
5	O-ring ^{2,3}	Specify	Specify	Specify	Specify	Specify	Specify	Specify	Specify
6	Guide	316 SS	316 SS	316 SS	Monel®	Monel®	Hastelloy® C	Hastelloy® C	316 SS
7	Spindle ⁸	416 SS	316 SS	316 SS	416 SS	Monel®	416 SS	Hastelloy® C	316 SS
8	Spring	17-7PH SS	316 SS	Inconel® X750	Inconel® X750	Inconel® X750	Inconel® X750	Hastelloy® C	Inconel® X750
9	Spring Washers	416 SS	316 SS	316 SS	316 SS	Monel®	316 SS	Hastelloy® C	316 SS
10	Adjusting Bolt	416 SS	316 SS	316 SS	416 SS	Monel®	416 SS	Hastelloy® C	316 SS
11	Adj. Bolt Nut	Carbon Steel	316 SS	316 SS	Carbon Steel	Monel®	Carbon Steel	Hastelloy® C	316 SS
12	Type A Cap ⁴	Carbon Steel	316 SS	316 SS	Carbon Steel	Monel®	Carbon Steel	Hastelloy® C	Carbon Steel
13	Nameplate ⁵	300 Series SS	300 Series SS	300 Series SS	300 Series SS	300 Series SS	300 Series SS	300 Series SS	300 Series SS
14	Drive Screws ⁵	SS	SS	SS	SS	SS	SS	SS	SS
15	Seal & Wire	Lead & SS	Lead & SS	Lead & SS	Lead & SS	Lead & SS	Lead & SS	Lead & SS	Lead & SS
30	Lap Joint Stub End (Inlet)	316 SS	316 SS	316 SS	Monel®	Monel®	Hastelloy® C	Hastelloy® C	316 SS
31	Inlet Flange	Carbon Steel ⁶	316 SS	316 SS	Carbon Steel ⁶	Carbon Steel ⁶	Carbon Steel ⁶	Carbon Steel ⁶	Carbon Steel ⁶
32	Lap Joint Stub End (Outlet)	Carbon Steel ⁶	316 SS	316 SS	Carbon Steel ⁶	Monel®	Carbon Steel ⁶	Hastelloy® C	Carbon Steel ⁶
33	Outlet Flange	Carbon Steel ⁶	316 SS	316 SS	Carbon Steel ⁶	Carbon Steel ⁶	Carbon Steel ⁶	Carbon Steel ⁶	Carbon Steel ⁶

Note: Blue shaded materials indicate variation from standard.

Notes

- Material is 17-4PH SS for steam applications.
- Refer to page 9 for pressure/temperature limits and available O-ring materials. Used on soft seated valve only.
- Recommended spare part.
- Refer to page 8 for other available cap styles and materials.
- Not shown.
- Low temperature limit for carbon steel flanges is -20°F [-28.9°C]. Use 316 SS below -20°F.**
- ASME Code Case 1750-17.
- Styles 9511 ()-STM and 9611 ()-STM spindle furnished as spindle and spindle ball sub-assembly.
- A nickel/graphite based lubricant/sealant is used on threads, sealing and bearing surfaces.

Caps and Lifting Levers

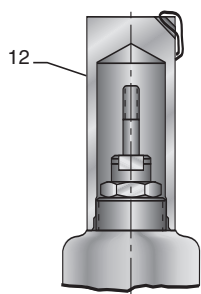

**Type A
Threaded Cap**

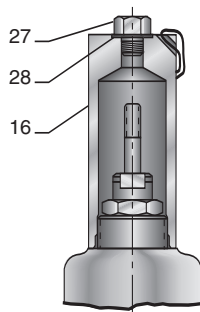

**Type B
Threaded Cap
with Test Rod**

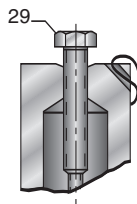

**View Showing
Valve Gagged
Types B and E
with Test Rod**

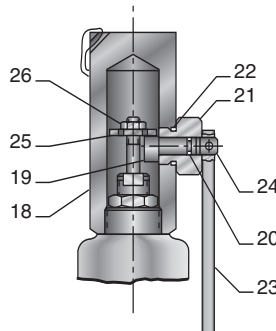

**Type D
Packed Lifting Lever**

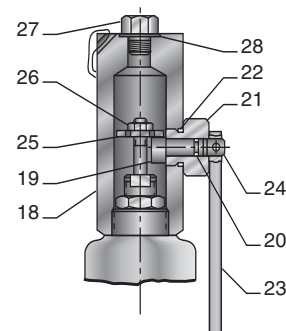

**Type E
Packed Lifting Lever
with Test Rod**

Materials of Construction

Material Designation →		0, 3, 5, 7	1, 2	4	6
Cap Type	Part No. Part Name				
A	12 Cap	Steel	316 SS	Monel®	Hastelloy® C
	16 Cap	Steel	316 SS	Monel®	Hastelloy® C
B	27 Cap Plug	Steel	316 SS	Monel®	Hastelloy® C
	28 Cap Plug O-ring	Viton®	Viton®	Viton®	Viton®
	29 Test Rod	Steel (Plated)	Steel (Plated)	Steel (Plated)	Steel (Plated)
D	18 Cap	Steel	316 SS	Monel®	Hastelloy® C
	19 Cam	416 SS	316 SS	Monel®	Hastelloy® C
	20 Cam O-ring	Viton®	Viton®	Viton®	Viton®
	21 Cam Sleeve	416 SS	316 SS	Monel®	Hastelloy® C
	22 Cam Sleeve O-ring	Viton®	Viton®	Viton®	Viton®
	23 Lever	Steel	Steel	Steel	Steel
	24 Lever Pin	302 SS	302 SS	302 SS	302 SS
	25 Spindle Nut	Steel	316 SS	Monel®	Hastelloy® C
26 Locknut	Steel (Plated)	300 Series SS	Monel®	Hastelloy® C	
E	18 Cap	Steel	316 SS	Monel®	Hastelloy® C
	19 Cam	416 SS	316 SS	Monel®	Hastelloy® C
	20 Cam O-ring	Viton®	Viton®	Viton®	Viton®
	21 Cam Sleeve	416 SS	316 SS	Monel®	Hastelloy® C
	22 Cam Sleeve O-ring	Viton®	Viton®	Viton®	Viton®
	23 Lever	Steel	Steel	Steel	Steel
	24 Lever Pin	302 SS	302 SS	302 SS	302 SS
	25 Spindle Nut	Steel	316 SS	Monel®	Hastelloy® C
	26 Locknut	Steel (Plated)	300 Series SS	Monel®	Hastelloy® C
27 Cap Plug	Steel	316 SS	Monel®	Hastelloy® C	
28 Cap Plug O-ring	Viton®	Viton®	Viton®	Viton®	
29 Test Rod	Steel (Plated)	Steel (Plated)	Steel (Plated)	Steel (Plated)	

Note: Blue shaded materials indicate variation from standard.

Crosby Series 800 Adjustable and Series 900 OMNI-TRIM® pressure relief valves are furnished with a threaded cap over the adjusting bolt as a standard. Optional cap types and lifting levers are described below.

1. Standard Threaded Cap (Type A)
Where no lifting lever is required.
2. Threaded Cap with Test Rod (Type B)
Normally used to hold the pressure relief valve closed when the system is being hydrostatically tested.
3. Packed Lifting Lever (Type D)
For applications where periodic testing is desirable. This is a sealed design for pressure integrity.
4. Packed Lifting Lever with Test Rod (Type E) Same as Type D except furnished with a test rod.

Note:

ASME Boiler and Pressure Vessel Code rules require that pressure relief valves used on air, water over 140°F [60°C] and steam shall have a lifting device. (Ref. Para. UG-136.)

Caution: Test Rods should never be tightened more than fingertight. Overtightening may damage internal parts. Moreover, a test rod should never be kept on the valve during operation of the equipment. During normal operation the test rod is replaced with cap plug and O-ring to maintain tightness on the discharge side.

Note

1. Viton® is a registered trademark of DuPont Dow Elastomers

Series 800 and Series 900 O-ring Soft Seats¹

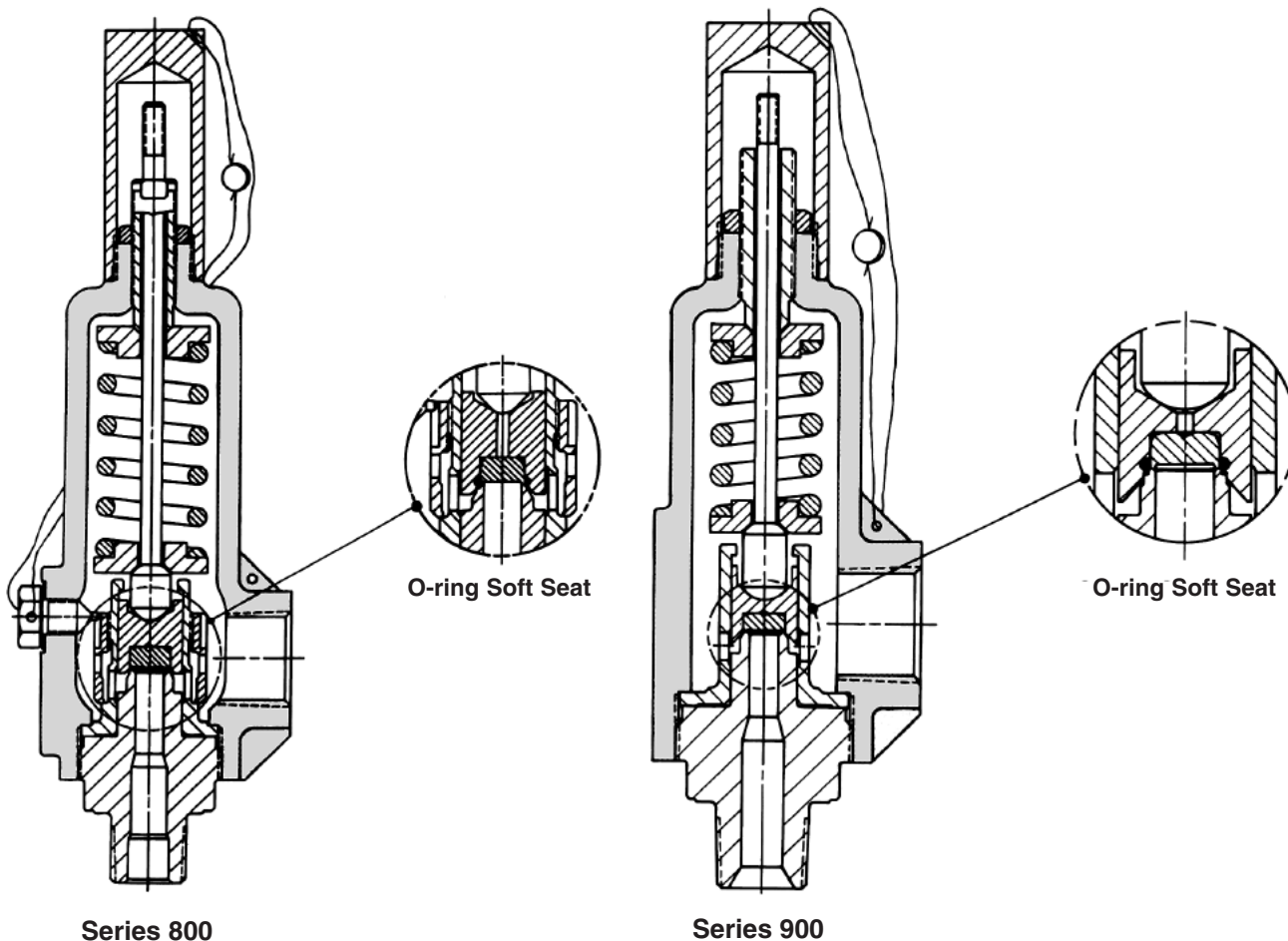

O-ring Soft Seat Materials ¹ and Pressure/Temperature Limits					
Material	Set Pressure psig [barg]			Inlet Temperature °F [°C]	
	Minimum	Maximum		Minimum	Maximum
		Series 800 only	Series 900 only		
BUNA-N	15 [1.03]	1500 [103.44]	2500 [172.41]	-50 [-45.6]	+250 [+121.1]
Viton®	15 [1.03]	1500 [103.44]	2500 [172.41]	0 [-17.8]	+400 [+204.4]
EPR*	15 [1.03]	1500 [103.44]	2500 [172.41]	-50 [-45.6]	+250 [+121.1]
Kalrez®	15 [1.03]	1500 [103.44]	2500 [172.41]	0 [-17.8]	+500 [+260.0]
TFE	100 [6.89]	1500 [103.44]	2500 [172.41]	-50 [-45.6]	+500 [+260.0]
Silicone	15 [1.03]	1500 [103.44]	1500 [103.44]	-50 [-45.6]	+400 [+204.4]

*EPR = Ethylene Propylene Rubber

Notes

1. For steam service, metal-to-metal seats are recommended. Consult factory if soft seats are required.
2. Kalrez® is a registered trademark of DuPont Dow Elastomers.

Specifications: Series 800 Threaded Connections (NPT) - USCS (U.S. Customary System) Units

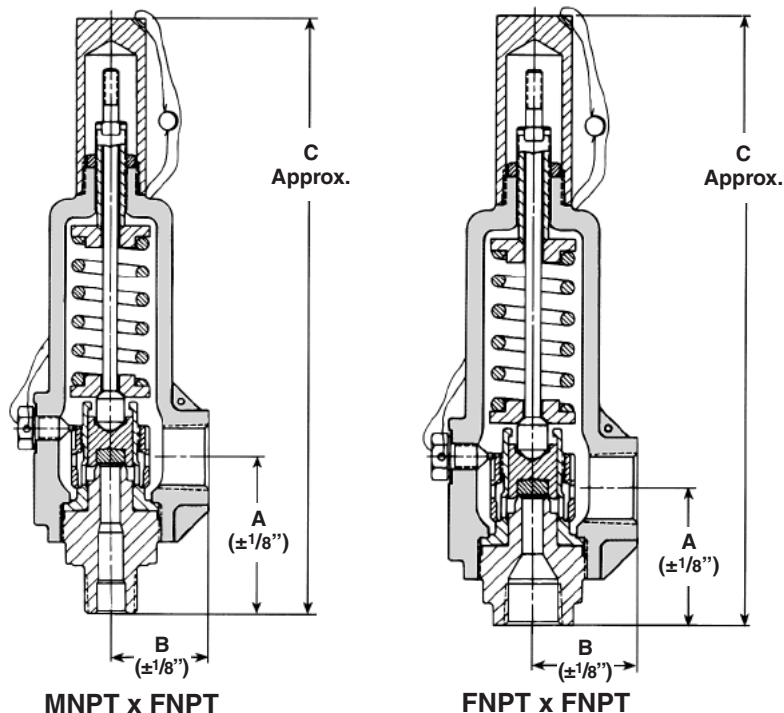

Series 800 Dimensions and Weights, Pressure/Temperature Ratings

Valve Style Number	Connection Size (NPS)		Minimum Set Press. psig	Maximum Set Press. ^{1,3} psig	Maximum Outlet Pressure psig	Temperature ¹ Range (°F)	Dimensions (in.)			Approx. Weight (lbs.)
	Inlet	Outlet					A	B	C ²	
Style 861 — Series 800 with No. 6 orifice (0.110 sq. in.) and 1500 psig maximum set pressure										
8611()1M	3/4	1	15	1500	400	-450/+750	3 1/8	1 15/16	11 7/8	10
8611()2M	1	1	15	1500	400	-450/+750	3 3/8	1 15/16	12 1/8	10
8611()1F	3/4	1	15	1500	400	-450/+750	2 1/2	1 15/16	11 1/4	10
8611()2F	1	1	15	1500	400	-450/+750	2 7/8	1 15/16	11 5/8	10
Style 871 — Series 800 with No. 7 orifice (0.196 sq. in.) and 1500 psig maximum set pressure										
8711()3M	1	1 1/2	15	1500	400	-450/+750	3 3/4	2 1/2	13 3/8	17
8711()4M	1 1/2	1 1/2	15	1500	400	-450/+750	3 3/4	2 1/2	13 3/8	17
8711()3F	1	1 1/2	15	1500	400	-450/+750	3 1/8	2 1/2	12 3/4	17
8711()4F	1 1/2	1 1/2	15	1500	400	-450/+750	3 3/8	2 1/2	13	17
Style 881 — Series 800 with No. 8 orifice (0.307 sq. in.) and 1500 psig maximum set pressure										
8811()5M	1 1/2	2	15	1500	400	-450/+750	4 1/2	3 1/4	16 3/8	33
8811()6M	2	2	15	1500	400	-450/+750	4 1/2	3 1/4	16 3/8	33
8811()5F	1 1/2	2	15	1500	400	-450/+750	3 7/8	3 1/4	15 3/4	33
8811()6F	2	2	15	1500	400	-450/+750	4	3 1/4	15 7/8	33
Style 891 — Series 800 with No. 9 orifice (0.503 sq. in.) and 1500 psig maximum set pressure										
8911()7M	1 1/2	2 1/2	15	1500	400	-450/+750	4 1/2	3 1/4	16 3/8	32
8911()7F	1 1/2	2 1/2	15	1500	400	-450/+750	3 7/8	3 1/4	15 3/4	32

Notes

- Minimum/maximum set pressures and temperatures shown apply to metal seated valves only. Refer to page 9 for soft seat pressure and temperature limits.
- Dimension "C" shown is for Type A cap. For Type B cap, add 1/4 in. to "C" dimension (an additional 2 in. is required for test rod head clearance). For Type D cap, add 5/8 in. to "C" dimension. For Type E cap, add 7/8 in. to "C" dimension (an additional 2 in. is required for test rod head clearance).
- Maximum set pressure for steam service is 1000 psig.

Specifications: Series 800 Flanged Connections (NPT) -
USCS (U.S. Customary System) Units

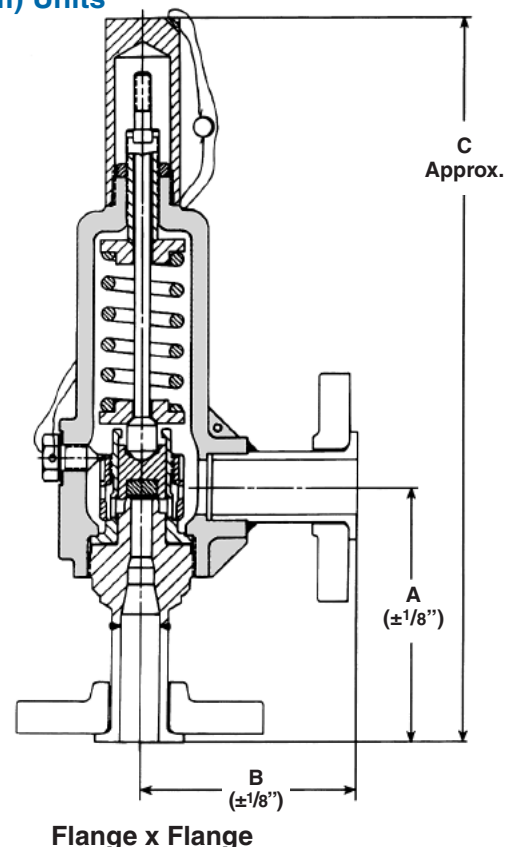

Series 800 Dimensions and Weights, Pressure/Temperature Ratings

Valve Style Number	Connection Size (NPS)		Std. ANSI Lap Joint Stub End Flanges ³		Maximum Set Pressure ^{1,2,5} @ 100°F (psig)	Dimensions (in.)			Approx. Weight (lbs.)
	Inlet	Outlet	Inlet	Outlet		A	B	C ⁴	
Style 861 — Series 800 with No. 6 orifice (0.110 sq. in.)									
8611()11	3/4	1	150	150	285	4 ³ / ₈	4 ¹ / ₄	13 ³ / ₁₆	14
8611()12	3/4	1	300	150	740	4 ³ / ₈	4 ¹ / ₄	13 ³ / ₁₆	15
8611()13	3/4	1	600	150	1480	4 ³ / ₈	4 ¹ / ₄	13 ³ / ₁₆	15
8611()21	1	1	150	150	285	4 ⁵ / ₈	4 ¹ / ₄	13 ⁷ / ₁₆	14
8611()22	1	1	300	150	740	4 ⁵ / ₈	4 ¹ / ₄	13 ⁷ / ₁₆	16
8611()23	1	1	600	150	1480	4 ⁵ / ₈	4 ¹ / ₄	13 ⁷ / ₁₆	16
Style 871 — Series 800 with No. 7 orifice (0.196 sq. in.)									
8711()31	1	1 ¹ / ₂	150	150	285	5 ¹ / ₈	5	14 ¹³ / ₁₆	24
8711()32	1	1 ¹ / ₂	300	150	740	5 ¹ / ₈	5	14 ¹³ / ₁₆	25
8711()33	1	1 ¹ / ₂	600	150	1480	5 ¹ / ₈	5	14 ¹³ / ₁₆	25
8711()41	1 ¹ / ₂	1 ¹ / ₂	150	150	285	5 ¹ / ₂	5	15 ³ / ₁₆	26
8711()42	1 ¹ / ₂	1 ¹ / ₂	300	150	740	5 ¹ / ₂	5	15 ³ / ₁₆	29
8711()43	1 ¹ / ₂	1 ¹ / ₂	600	150	1480	5 ¹ / ₂	5	15 ³ / ₁₆	29

Notes

- Maximum set pressures shown are based on carbon steel flanges. Pressure limits for 316 SS flanges may be lower. Consult Crosby.
 - Maximum set pressures apply to metal seated valves only; refer to page 9 for limits for soft seat construction.
 - Flanges are supplied with a serrated face per ANSI B16.5. Other facings/standards (i.e., DIN) are also available.
 - Dimension "C" shown is for Type A cap. For Type B cap, add 1/4 in. to "C" dimension (an additional 2 in. is required for test rod head clearance).
 - Maximum set pressure for steam service is 1000 psig.
- For Type D cap, add 5/8 in. to "C" dimension.
For Type E cap, add 7/8 in. to "C" dimension (an additional 2 in. is required for test rod head clearance).

Specifications: Series 800 Threaded Connections (NPT) - Metric Units

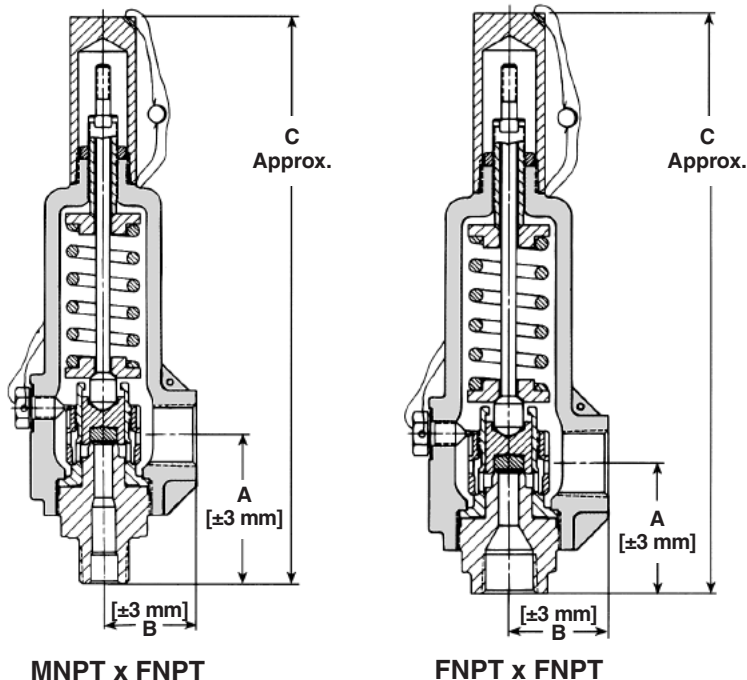

Series 800 Dimensions and Weights, Pressure/Temperature Ratings

Valve Style Number	Connection Size (NPS)		Minimum Set Press. [barg]*	Maximum ^{1,3} Set Press. [barg]*	Maximum Outlet Pressure [barg]*	Temperature ¹ Range [°C]	Dimensions (in.) [mm]			Approx. Weight [kg]
	Inlet	Outlet					A	B	C ²	
Style 861 — Series 800 with No. 6 orifice [70.96 sq. mm] and 103.42 barg maximum set pressure										
8611()1M	3/4	1	1.03	103.42	27.58	-268/+399	79	49	302	4
8611()2M	1	1	1.03	103.42	27.58	-268/+399	86	49	308	4
8611()1F	3/4	1	1.03	103.42	27.58	-268/+399	64	49	286	4
8611()2F	1	1	1.03	103.42	27.58	-268/+399	73	49	295	4
Style 871 — Series 800 with No. 7 orifice [126.4 sq. mm] and 103.42 barg maximum set pressure										
8711()3M	1	1 1/2	1.03	103.42	27.58	-268/+399	95	64	340	8
8711()4M	1 1/2	1 1/2	1.03	103.42	27.58	-268/+399	95	64	340	8
8711()3F	1	1 1/2	1.03	103.42	27.58	-268/+399	79	64	324	8
8711()4F	1 1/2	1 1/2	1.03	103.42	27.58	-268/+399	86	64	330	8
Style 881 — Series 800 with No. 8 orifice [198.0 sq. mm] and 103.42 barg maximum set pressure										
8811()5M	1 1/2	2	1.03	103.42	27.58	-268/+399	114	83	416	15
8811()6M	2	2	1.03	103.42	27.58	-268/+399	114	83	416	15
8811()5F	1 1/2	2	1.03	103.42	27.58	-268/+399	98	83	400	15
8811()6F	2	2	1.03	103.42	27.58	-268/+399	102	83	403	15
Style 891 — Series 800 with No. 9 orifice [324.5 sq. mm] and 103.42 barg maximum set pressure										
8911()7M	1 1/2	2 1/2	1.03	103.42	27.58	-268/+399	114	83	416	15
8911()7F	1 1/2	2 1/2	1.03	103.42	27.58	-268/+399	98	83	400	15

*To obtain units in kPa, multiply barg units by 100.

Notes

- Minimum/maximum set pressures and temperatures shown apply to metal seated valves only. Refer to page 9 for pressure and temperature limits for soft seat construction.
- Dimension "C" shown is for Type A cap.
For Type B cap, add 6 mm to "C" dimension (an additional 51 mm is required for test rod head clearance).
For Type D cap, add 16 mm to "C" dimension.
For Type E cap, add 22 mm to "C" dimension (an additional 51 mm is required for test rod head clearance).
- Maximum set pressure for steam service is 68.95 barg.

Specifications: Series 800 Flanged Connections (NPT) -
Metric Units

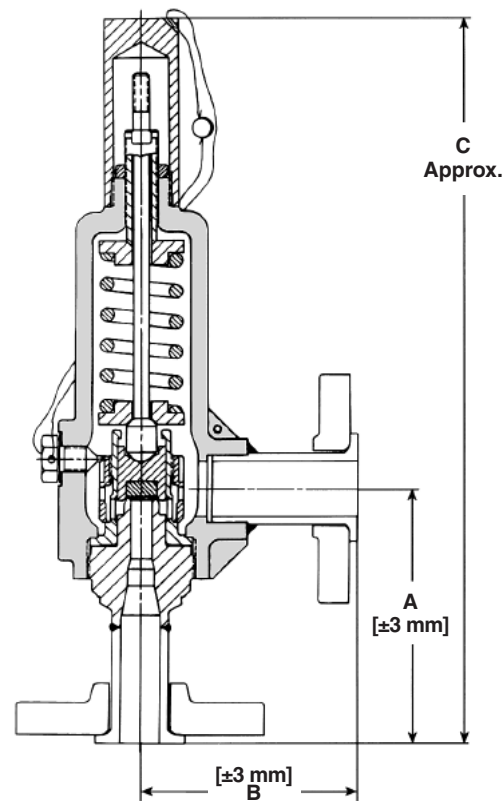

Flange x Flange

Series 800 Dimensions and Weights, Pressure/Temperature Ratings

Valve Style Number	Connection Size (NPS)		Std. ANSI Lap Joint Stub End Flanges ³		Maximum Set Pressure ^{1,2,5} @ 37.8°C [barg]	Dimensions [mm]			Approx. Weight [kg]
	Inlet	Outlet	Inlet	Outlet		A	B	C ⁴	
Style 861 — Series 800 with No. 6 orifice [70.96 sq. mm]									
8611()11	3/4	1	150	150	19.65	111	108	335	6
8611()12	3/4	1	300	150	51.02	111	108	335	7
8611()13	3/4	1	600	150	102.04	111	108	335	7
8611()21	1	1	150	150	19.65	117	108	341	7
8611()22	1	1	300	150	51.02	117	108	341	7
8611()23	1	1	600	150	102.04	117	108	341	7
Style 871 — Series 800 with No. 7 orifice [126.4 sq. mm]									
8711()31	1	1 1/2	150	150	19.65	130	127	376	11
8711()32	1	1 1/2	300	150	51.02	130	127	376	11
8711()33	1	1 1/2	600	150	102.04	130	127	376	11
8711()41	1 1/2	1 1/2	150	150	19.65	140	127	386	12
8711()42	1 1/2	1 1/2	300	150	51.02	140	127	386	13
8711()43	1 1/2	1 1/2	600	150	102.04	140	127	386	13

Notes

- Maximum set pressures shown are based on carbon steel flanges. Pressure limits for 316 SS flanges may be lower. Consult Crosby.
 - Maximum set pressures apply to metal seated valves only; Refer to page 9 for limits for soft seat construction.
 - Flanges are supplied with a serrated face per ANSI B16.5. Other facings/standards (i.e., DIN) are also available.
 - Dimension "C" shown is for Type A cap.
For Type B cap, add 6 mm to "C" dimension (an additional 51 mm is required for test rod head clearance).
 - Maximum set pressure for steam service is 68.95 barg.
- For Type D cap, add 16 mm to "C" dimension.
For Type E cap, add 22 mm to "C" dimension (an additional 51 mm is required for test rod head clearance).

Specifications: Series 900 OMNI-TRIM® Threaded Connections (NPT) - USCS (U.S. Customary System) Units

Series 900 Dimensions and Weights, Pressure/Temperature Ratings

Valve Style Number	Connection Size (NPS)		Min. ⁴ Set Press. (psig)	Max. ^{1,3} Set Press. (psig)	Max. Outlet Press. (psig)	Temp. ¹ Range (°F)	Dimensions (in.)			App. Wt. (lbs.)
	Inlet	Outlet					A	B	C ²	
Style 951 — Series 900 with No. 5 orifice (0.074 sq. in.)* and 1500 psig maximum set pressure										
9511()0M	1/2	1	5	1500	400	-450/+750	3	1 3/4	10 3/8	7
9511()1M	3/4	1	5	1500	400	-450/+750	3	1 3/4	10 3/8	7
9511()2M	1	1	5	1500	400	-450/+750	3 1/4	1 3/4	10 5/8	7
Style 951 — Series 900 Bolted Connection with No. 5 orifice (0.074 sq. in.) and 1500 psig max. set pressure⁵										
9511()19	3/4	1	5	1500	400	-450/+750	6 13/16	1 3/4	14 1/4	12
Style 955 — Series 900 with No. 5 orifice (0.074 sq. in.)* and 5000 psig maximum set pressure										
9551()0M	1/2	1	1501	5000	400	-450/+750	3 1/8	1 15/16	11 7/8	9
9551()1M	3/4	1	1501	5000	400	-450/+750	3 1/8	1 15/16	11 7/8	9
9551()2M	1	1	1501	5000	400	-450/+750	3 3/8	1 15/16	12 1/8	9
Style 961 — Series 900 with No. 6 orifice (0.110 sq. in.) and 1500 psig maximum set pressure										
9611()0M	1/2	1	5	1500	400	-450/+750	3 1/8	1 15/16	11 7/8	10
9611()1M	3/4	1	5	1500	400	-450/+750	3 1/8	1 15/16	11 7/8	10
9611()2M	1	1	5	1500	400	-450/+750	3 3/8	1 15/16	12 1/8	10
9611()1F	3/4	1	5	1500	400	-450/+750	2 1/2	1 15/16	11 1/4	10
9611()2F	1	1	5	1500	400	-450/+750	2 7/8	1 15/16	11 5/8	10
Style 965 — Series 900 with No. 6 orifice (0.110 sq. in.) and 5000 psig maximum set pressure										
9651()1M	3/4	1	1501	5000	400	-450/+750	3 1/2	2 1/2	13 1/8	16
9651()2M	1	1	1501	5000	400	-450/+750	3 3/4	2 1/2	13 3/8	16
9651()3M	1	1 1/2	1501	5000	400	-450/+750	3 3/4	2 1/2	13 3/8	16
9651()1F	3/4	1	1501	5000	400	-450/+750	2 7/8	2 1/2	12 1/2	16
9651()2F	1	1	1501	5000	400	-450/+750	3 1/8	2 1/2	12 3/4	16
9651()3F	1	1 1/2	1501	5000	400	-450/+750	3 1/8	2 1/2	12 3/4	16
Style 972 — Series 900 with No. 7 orifice (0.196 sq. in.) and 2500 psig maximum set pressure										
9721()3M	1	1 1/2	6	2500	400	-450/+750	3 3/4	2 1/2	13 3/8	17
9721()4M	1 1/2	1 1/2	6	2500	400	-450/+750	3 3/4	2 1/2	13 3/8	17
9721()3F	1	1 1/2	6	2500	400	-450/+750	3 1/8	2 1/2	12 3/4	17
9721()4F	1 1/2	1 1/2	6	2500	400	-450/+750	3 3/8	2 1/2	13	17
Style 981 — Series 900 with No. 8 orifice (0.307 sq. in.) and 1500 psig maximum set pressure										
9811()5M	1 1/2	2	7	1500	400	-450/+750	4 1/2	3 1/4	16 3/8	33
9811()6M	2	2	7	1500	400	-450/+750	4 1/2	3 1/4	16 3/8	33
9811()5F	1 1/2	2	7	1500	400	-450/+750	3 7/8	3 1/4	15 3/4	33
9811()6F	2	2	7	1500	400	-450/+750	4	3 1/4	15 7/8	33
Style 991 — Series 900 with No. 9 orifice (0.503 sq. in.) and 1500 psig maximum set pressure										
9911()7M	1 1/2	2 1/2	7	1500	400	-450/+750	4 1/2	3 1/4	16 3/8	32
9911()7F	1 1/2	2 1/2	7	1500	400	-450/+750	3 7/8	3 1/4	15 3/4	32

*Consult Crosby for availability of No. 5 (0.074 sq. in.) orifice with FNPT inlet.

Notes

- Minimum/maximum set pressures and temperatures shown apply to metal seated valves only. Refer to page 9 for pressure and temperature limits for soft seat construction.
- Dimension "C" shown is for Type A cap.
For Type B cap, add 1/4 in. to "C" dimension (an additional 2 in. is required for test rod head clearance).
For Type D cap, add 5/8 in. to "C" dimension.
For Type E cap, add 7/8 in. to "C" dimension (an additional 2 in. is required for test rod head clearance).
- Maximum set pressure for steam service is 1000 psig.
- Valves set below 15 psig cannot be stamped with the ASME Code Symbol. Only metal seated valves may be set below 15 psig. For set pressure applications below the published minimum values, consult Crosby.
- See page 3.

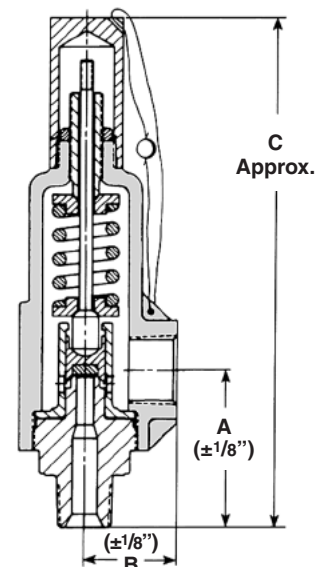

MNPT x FNPT

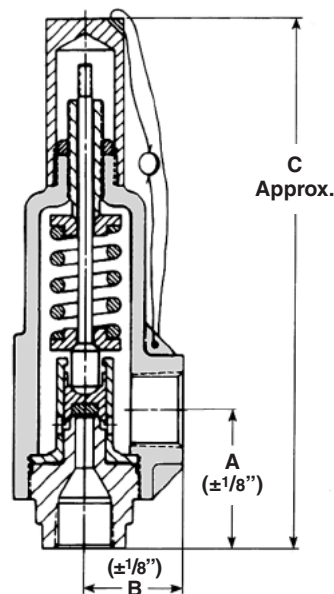

FNPT x FNPT

Specifications: Series 900 OMNI-TRIM® Flanged Connections - USCS (U.S. Customary System) Units

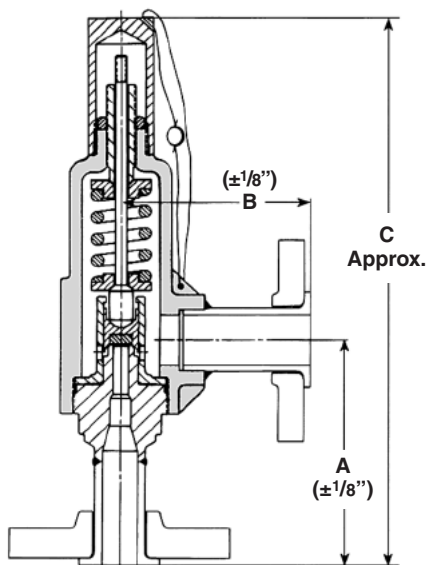

Flange x Flange

Series 900 Dimensions and Weights, Pressure/Temperature Ratings

Valve Style Number	Connection Size (NPS)		Std. ANSI Lap Joint Stub End Flanges ⁴		Max. ^{1,2,6} Set Press. @ 100°F (psig)	Max. Outlet Press. (psig)	Dimensions (in.)			Approx. Wt. (lbs.)
	Inlet	Outlet	Inlet	Outlet			A	B	C ⁵	
Style 951 — Series 900 with No. 5 orifice (0.074 sq. in.)										
9511()01	1/2	1	150	150	285	285	4 1/4	4	11 11/16	10
9511()02	1/2	1	300	150	740	285	4 1/4	4	11 11/16	11
9511()03	1/2	1	600	150	1480	285	4 1/4	4	11 11/16	11
9511()11	3/4	1	150	150	285	285	4 1/4	4	11 11/16	11
9511()12	3/4	1	300	150	740	285	4 1/4	4	11 11/16	12
9511()13	3/4	1	600	150	1480	285	4 1/4	4	11 11/16	12
9511()21	1	1	150	150	285	285	4 1/2	4	11 15/16	12
9511()22	1	1	300	150	740	285	4 1/2	4	11 15/16	13
9511()23	1	1	600	150	1480	285	4 1/2	4	11 15/16	13
Style 955 — Series 900 with No. 5 orifice (0.074 sq. in.)										
9551()14	3/4	1	1500	3	3705	400 ³	5 1/2	4 1/2	14 5/16	19
9551()15	3/4	1	2500	3	5000	400 ³	5 1/2	4 1/2	14 5/16	21
9551()24	1	1	1500	3	3705	400 ³	5 3/4	4 1/2	14 9/16	21
9551()25	1	1	2500	3	5000	400 ³	5 3/4	4 1/2	14 9/16	25
Style 961 — Series 900 with No. 6 orifice (0.110 sq. in.)										
9611()01	1/2	1	150	150	285	285	4 3/8	4 1/4	13 3/16	14
9611()02	1/2	1	300	150	740	285	4 3/8	4 1/4	13 3/16	15
9611()03	1/2	1	600 ⁷	150	1480	285	4 3/8	4 1/4	13 3/16	15
9611()11	3/4	1	150	150	285	285	4 3/8	4 1/4	13 3/16	14
9611()12	3/4	1	300	150	740	285	4 3/8	4 1/4	13 3/16	15
9611()13	3/4	1	600	150	1480	285	4 3/8	4 1/4	13 3/16	15
9611()21	1	1	150	150	285	285	4 5/8	4 1/4	13 7/16	14
9611()22	1	1	300	150	740	285	4 5/8	4 1/4	13 7/16	16
9611()23	1	1	600	150	1480	285	4 5/8	4 1/4	13 7/16	16
Style 965 — Series 900 with No. 6 orifice (0.110 sq. in.)										
9651()14	3/4	1	1500	3	3705	400 ³	6	5	15 11/16	26
9651()24	1	1	1500	3	3705	400 ³	6 1/4	5	15 15/16	29
9651()25	1	1	2500	3	5000	400 ³	6 1/4	5	15 15/16	32
9651()34	1	1 1/2	1500	3	3705	400 ³	6 1/4	5 3/4	15 15/16	29
9651()35	1	1 1/2	2500	3	5000	400 ³	6 1/4	5 3/4	15 15/16	35
Style 972 — Series 900 with No. 7 orifice (0.196 sq. in.)										
9721()31	1	1 1/2	150	150	285	285	5 1/8	5	14 13/16	24
9721()32	1	1 1/2	300	150	740	285	5 1/8	5	14 13/16	25
9721()33	1	1 1/2	600	150	1480	285	5 1/8	5	14 13/16	25
9721()34	1	1 1/2	1500	3	2500	400 ³	6	5 3/4	15 11/16	32
9721()41	1 1/2	1 1/2	150	150	285	285	5 1/2	5	15 3/16	26
9721()42	1 1/2	1 1/2	300	150	740	285	5 1/2	5	15 3/16	29
9721()43	1 1/2	1 1/2	600	150	1480	285	5 1/2	5	15 3/16	29
9721()44	1 1/2	1 1/2	1500	3	2500	400 ³	6	5 3/4	15 11/16	38
Style 981 — Series 900 with No. 8 orifice (0.307 sq. in.)										
9811()51	1 1/2	2	150	150	285	285	6 1/2	6	18 7/16	44
9811()52	1 1/2	2	300	150	740	285	6 1/2	6	18 7/16	47
9811()53	1 1/2	2	600	150	1480	285	6 1/2	6	18 7/16	47
9811()61	2	2	150	150	285	285	6 3/4	6	18 11/16	46
9811()62	2	2	300	150	740	285	6 3/4	6	18 11/16	48
9811()63	2	2	600	150	1480	285	6 3/4	6	18 11/16	49
Style 991 — Series 900 with No. 9 orifice (0.503 sq. in.)										
9911()71	1 1/2	2 1/2	150	150	285	285	6 1/2	6 1/2	18 7/16	47
9911()72	1 1/2	2 1/2	300	150	740	285	6 1/2	6 1/2	18 7/16	50
9911()73	1 1/2	2 1/2	600	150	1480	285	6 1/2	6 1/2	18 7/16	50

Notes

- Maximum set pressures shown are based on carbon steel flanges. Pressure limits for 316 SS flanges may be lower. Consult Crosby.
- Maximum set pressures apply to metal seated valves only; refer to page 9 for limits for soft seat construction.
- ANSI CL 300 supplied; however, the maximum back pressure is 400 psig.
- Flanges are supplied with a serrated face per ANSI B16.5. Other facings/standards (i.e., DIN) are also available.
- Dimension "C" shown is for Type A cap.
For Type B cap, add 1/4 in. to "C" dimension (an additional 2 in. is required for test rod head clearance).
For Type D cap, add 5/8 in. to "C" dimension.
For Type E cap, add 7/8 in. to "C" dimension (an additional 2 in. is required for test rod head clearance).
- Maximum set pressure for steam service is 1000 psig.
- ANSI CI 600 flange integral with base.

Specifications: Series 900 OMNI-TRIM® Threaded Connections - Metric Units

Series 900 Dimensions and Weights, Pressure/Temperature Ratings

Valve Style Number	Connection Size (NPS)		Min. ⁴ Set Press. [barg]	Max. ^{1,3} Set Press. [barg]	Max. Outlet Press. [barg]*	Temp. ¹ Range [°C]	Dimensions [mm]			Appr. Wt. [kg]
	Inlet	Outlet					A	B	C ²	
Style 951 — Series 900 with No. 5 orifice [47.74 sq. mm]** and 103.42 barg maximum set pressure										
9511()0M	1/2	1	0.34	103.42	27.58	-268/+399	76	45	264	3
9511()1M	3/4	1	0.34	103.42	27.58	-268/+399	76	45	264	3
9511()2M	1	1	0.34	103.42	27.58	-268/+399	83	45	270	3
Style 951 — Series 900 Bolted Cylinder with No. 5 orifice [47.74 sq. mm] and 103.42 barg max. set pressure										
9511()19	3/4	1	0.34	103.42	27.58	-268/+399	173	44	362	5
Style 955 — Series 900 with No. 5 orifice [47.74 sq. mm]** and 344.74 barg maximum set pressure										
9551()0M	1/2	1	103.49	344.74	27.58	-268/+399	79	49	302	4
9551()1M	3/4	1	103.49	344.74	27.58	-268/+399	79	49	302	4
9551()2M	1	1	103.49	344.74	27.58	-268/+399	86	49	308	4
Style 961 — Series 900 with No. 6 orifice [70.96 sq. mm] and 103.42 barg maximum set pressure										
9611()0M	1/2	1	0.34	103.42	27.58	-268/+399	79	49	302	4
9611()1M	3/4	1	0.34	103.42	27.58	-268/+399	79	49	302	4
9611()2M	1	1	0.34	103.42	27.58	-268/+399	86	49	308	4
9611()1F	3/4	1	0.34	103.42	27.58	-268/+399	64	49	286	4
9611()2F	1	1	0.34	103.42	27.58	-268/+399	73	49	295	4
Style 965 — Series 900 with No. 6 orifice [70.96 sq. mm] and 344.74 barg maximum set pressure										
9651()1M	3/4	1	103.49	344.74	27.58	-268/+399	89	64	333	7
9651()2M	1	1	103.49	344.74	27.58	-268/+399	95	64	340	7
9651()3M	1	1 1/2	103.49	344.74	27.58	-268/+399	95	64	340	7
9651()1F	3/4	1	103.49	344.74	27.58	-268/+399	73	64	318	7
9651()2F	1	1	103.49	344.74	27.58	-268/+399	79	64	324	7
9651()3F	1	1 1/2	103.49	344.74	27.58	-268/+399	79	64	324	7
Style 972 — Series 900 with No. 7 orifice [126.4 sq. mm] and 172.36 barg maximum set pressure										
9721()3M	1	1 1/2	0.41	172.36	27.58	-268/+399	95	64	340	8
9721()4M	1 1/2	1 1/2	0.41	172.36	27.58	-268/+399	95	64	340	8
9721()3F	1	1 1/2	0.41	172.36	27.58	-268/+399	79	64	324	8
9721()4F	1 1/2	1 1/2	0.41	172.36	27.58	-268/+399	86	64	330	8
Style 981 — Series 900 with No. 8 orifice [198.0 sq. mm] and 103.42 barg maximum set pressure										
9811()5M	1 1/2	2	0.48	103.42	27.58	-268/+399	114	83	416	15
9811()6M	2	2	0.48	103.42	27.58	-268/+399	114	83	416	15
9811()5F	1 1/2	2	0.48	103.42	27.58	-268/+399	98	83	400	15
9811()6F	2	2	0.48	103.42	27.58	-268/+399	102	83	403	15
Style 991 — Series 900 with No. 9 orifice [324.5 sq. mm] and 103.42 barg maximum set pressure										
9911()7M	1 1/2	2 1/2	0.48	103.42	27.58	-268/+399	114	83	416	15
9911()7F	1 1/2	2 1/2	0.48	103.42	27.58	-268/+399	98	83	400	15

* To obtain units in kPa, multiply barg units by 100.

** Consult Crosby for availability of No. 5 [47.74 sq. mm] orifice with FNPT inlet.

Notes

- Minimum/maximum set pressures and temperatures shown apply to metal seated valves only. Refer to page 9 for pressure and temperature limits for soft seat construction.
- Dimension "C" shown is for Type A cap.
For Type B cap, add 6 mm to "C" dimension (an additional 51 mm is required for test rod head clearance).
For Type D cap, add 16 mm to "C" dimension.
For Type E cap, add 22 mm to "C" dimension (an additional 51 mm is required for test rod head clearance).
- Maximum set pressure for steam service is 68.95 barg.
- Valves set below 1.03 barg cannot be stamped with the ASME Code Symbol. Only metal seated valves may be set below 1.03 barg.

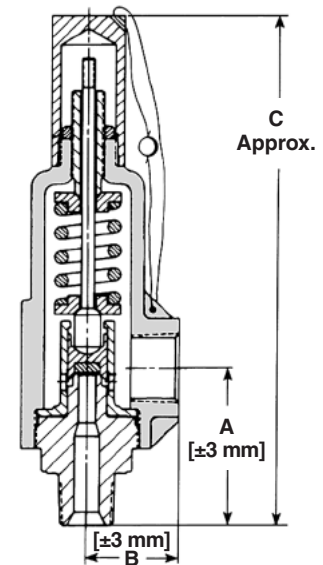

MNPT x FNPT

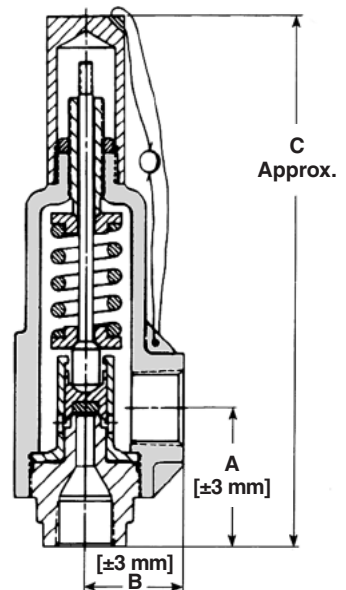

FNPT x FNPT

Specification: Series 900 OMNI-TRIM® Flanged Connections - Metric Units

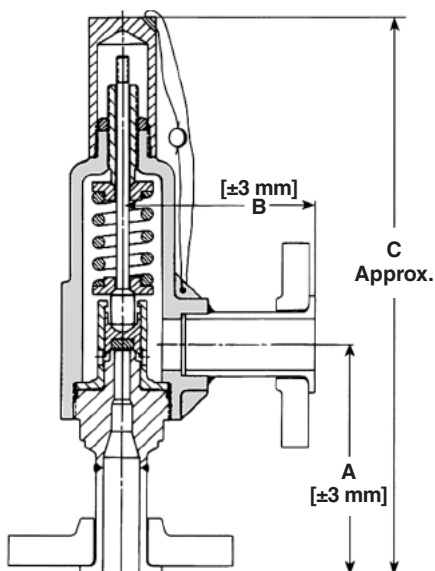

Flange x Flange

Series 900 Dimensions and Weights, Pressure/Temperature Ratings

Valve Style Number	Connection Size (NPS)		Std. ANSI Lap Joint Stub End Flanges ⁴		Max. ^{1,2,6} Set Press. @ 37.8°C [barg]	Max. Outlet Press. [barg]	Dimensions [mm]			Approx. Wt. [kg]
	Inlet	Outlet	Inlet	Outlet			A	B	C ⁵	
Style 951 — Series 900 with No. 5 orifice [47.74 sq. mm]										
9511()01	1/2	1	150	150	19.65	19.65	108	102	297	5
9511()02	1/2	1	300	150	51.02	19.65	108	102	297	5
9511()03	1/2	1	600	150	102.04	19.65	108	102	297	5
9511()11	3/4	1	150	150	19.65	19.65	108	102	297	5
9511()12	3/4	1	300	150	51.02	19.65	108	102	297	6
9511()13	3/4	1	600	150	102.04	19.65	108	102	297	6
9511()21	1	1	150	150	19.65	19.65	114	102	303	5
9511()22	1	1	300	150	51.02	19.65	114	102	303	6
9511()23	1	1	600	150	102.04	19.65	114	102	303	6
Style 955 — Series 900 with No. 5 orifice [47.74 sq. mm]										
9551()14	3/4	1	1500	3	255.45	27.58 ³	140	114	364	8
9551()15	3/4	1	2500	3	344.74	27.58 ³	140	114	364	10
9551()24	1	1	1500	3	255.45	27.58 ³	146	114	370	10
9551()25	1	1	2500	3	344.74	27.58 ³	146	114	370	11
Style 961 — Series 900 with No. 6 orifice [70.96 sq. mm]										
9611()01	1/2	1	150	150	19.65	19.65	111	108	335	6
9611()02	1/2	1	300	150	51.02	19.65	111	108	335	7
9611()03	1/2	1	600 ⁷	150	102.04	19.65	111	108	335	7
9611()11	3/4	1	150	150	19.65	19.65	111	108	335	6
9611()12	3/4	1	300	150	51.02	19.65	111	108	335	7
9611()13	3/4	1	600	150	102.04	19.65	111	108	335	7
9611()21	1	1	150	150	19.65	19.65	117	108	341	7
9611()22	1	1	300	150	51.02	19.65	117	108	341	7
9611()23	1	1	600	150	102.04	19.65	117	108	341	7
Style 965 — Series 900 with No. 6 orifice [70.96 sq. mm]										
9651()14	3/4	1	1500	3	255.45	27.58 ³	152	127	398	12
9651()24	1	1	1500	3	255.45	27.58 ³	159	127	405	13
9651()25	1	1	2500	3	344.74	27.58 ³	159	127	405	14
9651()34	1	1 1/2	1500	3	255.45	27.58 ³	159	146	405	13
9651()35	1	1 1/2	2500	3	344.74	27.58 ³	159	146	405	16
Style 972 — Series 900 with No. 7 orifice [126.4 sq. mm]										
9721()31	1	1 1/2	150	150	19.65	19.65	130	127	376	11
9721()32	1	1 1/2	300	150	51.02	19.65	130	127	376	11
9721()33	1	1 1/2	600	150	102.04	19.65	130	127	376	11
9721()34	1	1 1/2	1500	3	172.36	27.58 ³	152	146	398	15
9721()41	1 1/2	1 1/2	150	150	19.65	19.65	140	127	386	12
9721()42	1 1/2	1 1/2	300	150	51.02	19.65	140	127	386	13
9721()43	1 1/2	1 1/2	600	150	102.04	19.65	140	127	386	13
9721()44	1 1/2	1 1/2	1500	3	172.36	27.58 ³	152	146	398	17
Style 981 — Series 900 with No. 8 orifice [198.0 sq. mm]										
9811()51	1 1/2	2	150	150	19.65	19.65	165	152	468	20
9811()52	1 1/2	2	300	150	51.02	19.65	165	152	468	21
9811()53	1 1/2	2	600	150	102.04	19.65	165	152	468	21
9811()61	2	2	150	150	19.65	19.65	171	152	475	21
9811()62	2	2	300	150	51.02	19.65	171	152	475	22
9811()63	2	2	600	150	102.04	19.65	171	152	475	22
Style 991 — Series 900 with No. 9 orifice [324.5 sq. mm]										
9911()71	1 1/2	2 1/2	150	150	19.65	19.65	165	165	468	21
9911()72	1 1/2	2 1/2	300	150	51.02	19.65	165	165	468	23
9911()73	1 1/2	2 1/2	600	150	102.04	19.65	165	165	468	23

Notes

- Maximum set pressures shown are based on carbon steel flanges. Pressure limits for 316 SS flanges may be lower. Consult Crosby.
- Maximum set pressures apply to metal seated valves only; refer to page 9 for limits for soft seat construction.
- ANSI CL 300 supplied; however, the maximum back pressure is 27.58 barg.
- Flanges are supplied with a serrated face per ANSI B16.5. Other facings/standards (i.e., DIN) are also available.
- Dimension "C" shown is for Type A cap.
For Type B cap, add 6 mm to "C" dimension (an additional 51 mm is required for test rod head clearance).
For Type D cap, add 16 mm to "C" dimension.
For Type E cap, add 22 mm to "C" dimension (an additional 51 mm is required for test rod head clearance).
- Maximum set pressure for steam service is 68.95 barg.
- ANSI CI 600 flange integral with base.

Air Capacities Series 800* and Series 900 Valves - USCS (U.S. Customary System) Units

Note: For air capacities, USCS Units are exact equivalents of Imperial Units.

Air Capacities - Set Pressures 5-5000 psig

Set Pressure (psig)	Effective Area (sq. in.)				
	0.074	0.110	0.196	0.307	0.503
	1.4	2.1	3.8	6.0	9.8
1 psi incr. ¹	7.2	10.8	19.2	30.2	49.4
5 psi incr.					
5	29.3	43.5			
6	31.0	46.1			
7	32.5	48.4	82.2		
8	33.9	50.4	86.2	135	221
9	35.3	52.5	89.9	140	230
10	36.6	54.5	93.6	146	240
			97.1	152	249
15	43.2	64.0	114	179	294
20	49.9	74.0	132	207	339
30	63.1	93.0	167	261	429
40	77.7	115	205	322	528
50	92.2	137	244	382	627
60	106	158	282	443	726
70	121	180	321	503	825
80	135	202	360	563	924
90	150	223	398	624	1023
100	165	245	437	684	1122
120	194	288	514	805	1319
140	223	331	591	926	1517
160	252	375	668	1047	1715
180	281	418	745	1168	1913
200	310	461	822	1288	2111
220	339	505	900	1409	2309
240	368	548	977	1530	2507
260	398	591	1054	1651	2705
280	427	634	1131	1772	2903
300	456	678	1208	1892	3101
320	485	721	1285	2013	3299
340	514	764	1362	2134	3497
360	543	808	1439	2255	3695
380	572	851	1517	2376	3893
400	601	894	1594	2497	4091
420	631	937	1671	2617	4289
440	660	981	1748	2738	4487
460	689	1024	1825	2859	4685
480	718	1067	1902	2980	4883
500	747	1111	1979	3101	5081
520	776	1154	2057	3221	5278
540	805	1197	2134	3342	5476
560	834	1241	2211	3463	5674
580	863	1284	2288	3584	5872
600	893	1327	2365	3705	6070
620	922	1370	2442	3826	6268
640	951	1414	2519	3946	6466
660	980	1457	2596	4067	6664
680	1009	1500	2674	4188	6862
700	1038	1544	2751	4309	7060
720	1067	1587	2828	4430	7258
740	1096	1630	2905	4550	7456

Set Pressure (psig)	Effective Area (sq. in.)				
	0.074	0.110	0.196	0.307	0.503
	1.4	2.1	3.8	6.0	9.8
1 psi incr.	7.2	10.8	19.2	30.2	49.4
5 psi incr.					
760	1126	1673	2982	4671	7654
780	1155	1717	3059	4792	7852
800	1184	1760	3136	4913	8050
820	1213	1803	3214	5034	8248
840	1242	1847	3291	5155	8446
860	1271	1890	3368	5275	8644
880	1300	1933	3445	5396	8842
900	1329	1976	3522	5517	9039
920	1359	2020	3599	5638	9237
940	1388	2063	3676	5759	9435
960	1417	2106	3753	5879	9633
980	1446	2150	3831	6000	9831
1000	1475	2193	3908	6121	10029
1100	1621	2409	4293	6725	11019
1200	1766	2626	4679	7329	12009
1300	1912	2842	5065	7933	12998
1400	2057	3059	5450	8537	13988
1500	2203	3275	5836	9141	14978
1600	2349	3492	6222		
1700	2494	3708	6607		
1800	2640	3924	6993		
1900	2786	4141	7379		
2000	2931	4357	7764		
2100	3077	4574	8150		
2200	3222	4790	8536		
2300	3368	5007	8921		
2400	3514	5223	9307		
2500	3659	5440	9693		
2600	3805	5656			
2700	3950	5872			
2800	4096	6089			
2900	4242	6305			
3000	4387	6522			
3100	4533	6738			
3200	4678	6955			
3300	4824	7171			
3400	4970	7388			
3500	5115	7604			
3600	5261	7820			
3700	5406	8037			
3800	5552	8253			
3900	5698	8470			
4000	5843	8686			
4200	6135	9119			
4400	6426	9552			
4600	6717	9985			
4800	7008	10418			
5000	7299	10851			

*Series 800 capacities are in blue screened area only.

Notes

1. Not valid below 30 psig set pressure.
2. Capacities below 30 psig set pressure are calculated at 3 psi overpressure.
3. To determine capacities on gases other than air or vapors, for fluid temperatures other than 60°F, or if back pressure is specified, use the gas and vapor sizing formula in the Crosby Engineering Handbook.
4. The scope of the ASME Code, Section VIII, does not include pressures below 15 psig and therefore pressure relief valves set below 15 psig are not stamped with the ASME Code Symbol.

Capacity in standard cubic feet per minute of air at 60°F and 10% overpressure. Valve discharging to atmospheric pressure.²

Capacities certified by the National Board of Boiler and Pressure Vessel Inspectors and in accordance with the ASME Boiler and Pressure Vessel Code, Section VIII.

Saturated Steam Capacities Unfired Pressure Vessel Service Series 800* and Series 900 Valves USCS (U.S. Customary System) Units

Note: For steam capacities, USCS Units are exact equivalents of Imperial Units.

Saturated Steam Capacities - Set Pressures 5-1000 psig											
Set Pressure (psig)	Effective Area (sq. in.)					Set Pressure (psig)	Effective Area (sq. in.)				
	0.074	0.110	0.196	0.307	0.503		0.074	0.110	0.196	0.307	0.503
1 psi incr. / 5 psi incr.	4.0 / 20.4	6.0 / 30.3	10.8 / 54.1	16.9 / 84	27.7 / 138	1 psi incr. / 5 psi incr.	4.0 / 20.4	6.0 / 30.3	10.8 / 54.1	16.9 / 84	27.7 / 138
5	82.3	122				360	1526	2268	4041	6331	10373
6	87.1	129	230			370	1566	2329	4150	6500	10650
7	91.4	135	242			380	1607	2389	4258	6670	10928
8	95.3	141	252	395	647	390	1648	2450	4366	6839	11206
9	99.2	147	262	411	674	400	1689	2511	4474	7009	11484
10	102	152	272	427	699	410	1730	2572	4583	7178	11762
15	121	180	321	504	825	420	1771	2632	4691	7348	12039
20	140	208	371	581	952	430	1812	2693	4799	7518	12317
30	177	263	469	735	1204	440	1853	2754	4908	7687	12595
40	218	324	577	904	1482	450	1893	2815	5016	7857	12873
50	258	384	685	1074	1760	460	1934	2876	5124	8026	13151
60	299	445	794	1244	2038	470	1975	2936	5232	8196	13429
70	340	506	902	1413	2316	480	2016	2997	5341	8365	13706
80	381	567	1010	1583	2593	490	2057	3058	5449	8535	13984
90	422	628	1118	1752	2871	500	2098	3119	5557	8704	14262
100	463	688	1227	1922	3149	520	2180	3240	5774	9044	14818
110	504	749	1335	2091	3427	540	2261	3362	5990	9383	15373
120	545	810	1443	2261	3705	560	2343	3483	6207	9722	15929
130	585	871	1552	2430	3983	580	2425	3605	6423	10061	16485
140	626	931	1660	2600	4260	600	2506	3726	6640	10400	17040
150	667	992	1768	2770	4538	620	2588	3848	6856	10739	17596
160	708	1053	1876	2939	4816	640	2670	3969	7073	11078	18152
170	749	1114	1985	3109	5094	660	2752	4091	7289	11418	18707
180	790	1174	2093	3278	5372	680	2833	4212	7506	11757	19263
190	831	1235	2201	3448	5649	700	2915	4334	7722	12096	19819
200	872	1296	2309	3617	5927	720	2997	4455	7939	12435	20374
210	912	1357	2418	3787	6205	740	3079	4577	8155	12774	20930
220	953	1417	2526	3957	6483	760	3160	4698	8372	13113	21486
230	994	1478	2634	4126	6761	780	3242	4820	8588	13452	22041
240	1035	1539	2742	4296	7039	800	3324	4941	8805	13792	22597
250	1076	1600	2851	4465	7316	820	3406	5063	9021	14131	23152
260	1117	1660	2959	4635	7594	840	3487	5184	9238	14470	23708
270	1158	1721	3067	4804	7872	860	3569	5306	9454	14809	24264
280	1199	1782	3175	4974	8150	880	3651	5427	9671	15148	24819
290	1239	1843	3284	5144	8428	900	3733	5549	9887	15487	25375
300	1280	1903	3392	5313	8706	920	3814	5670	10104	15826	25931
310	1321	1964	3500	5483	8983	940	3896	5792	10320	16165	26486
320	1362	2025	3608	5652	9261	960	3978	5913	10537	16505	27042
330	1403	2086	3717	5822	9539	980	4060	6035	10753	16844	27598
340	1444	2146	3825	5991	9817	1000	4141	6156	10970	17183	28153
350	1485	2207	3933	6161	10095						

*Series 800 capacities are in blue screened area only.

Notes

- Not valid below 30 psig set pressure.
- Capacities below 30 psig set pressure are calculated at 3 psi overpressure.
- Maximum set pressure for steam service is 1000 psig.
- To determine capacities on superheated steam or if back pressure is specified, use the steam sizing formula in the Crosby Engineering Handbook.
- The scope of the ASME Code, Section VIII, does not include pressures below 15 psig and therefore pressure relief valves set below 15 psig are not stamped with the ASME Code Symbol.

Capacity in pounds per hour of steam at 10% overpressure. Valve discharging to atmospheric pressure.²

Capacities certified by the National Board of Boiler and Pressure Vessel Inspectors and in accordance with the ASME Boiler and Pressure Vessel Code, Section VIII.

Water Capacities Series 900 OMNI-TRIM® Valves - USCS (U.S. Customary System) Units

Note: USCS Units for water and liquids are U.S. gallons per minute (1 U.S. gallon equals .833 Imperial gallon).

Water Capacities - Differential Pressures ΔP / 5-5500 psi²

Diff. Pressure ΔP (psi)	Effective Area (sq. in.)					Diff. Pressure ΔP (psi)	Effective Area (sq. in.)				
	0.074	0.110	0.196	0.307	0.503		0.074	0.110	0.196	0.307	0.503
5	4.6	6.9				940	63.8	94.9	169	264	433
10	6.5	9.7	17.4			960	64.5	95.9	170	267	438
15	8.0	11.9	21.3	33.4	54.8	980	65.1	96.9	172	270	443
20	9.3	13.8	24.6	38.6	63.3	1000	65.8	97.8	174	273	447
40	13.1	19.5	34.8	54.6	89.5	1100	69.0	102	182	286	469
60	16.1	23.9	42.7	66.9	109	1200	72.1	107	191	299	490
80	18.6	27.6	49.3	77.2	126	1300	75.0	111	198	311	510
100	20.8	30.9	55.1	86.3	141	1400	77.9	115	206	323	529
120	22.8	33.9	60.4	94.6	155	1500	80.6	119	213	334	548
140	24.6	36.6	65.2	102	167	1600	83.2	123	220	345	566
160	26.3	39.1	69.7	109	179	1700	85.8	127	227		
180	27.9	41.5	73.9	115	189	1800	88.3	131	234		
200	29.4	43.7	78.0	122	200	1900	90.7	134	240		
220	30.8	45.9	81.8	128	209	2000	93.1	138	246		
240	32.2	47.9	85.4	133	219	2100	95.4	141	252		
260	33.5	49.9	88.9	139	228	2200	97.6	145	258		
280	34.8	51.7	92.2	144	236	2300	99.8	148	264		
300	36.0	53.6	95.5	149	245	2400	102	151	270		
320	37.2	55.3	98.6	154	253	2500	104	154	275		
340	38.3	57.0	101	159	260	2600	106	157	281		
360	39.5	58.7	104	163	268	2700	108	160	286		
380	40.5	60.3	107	168	275	2800	110	163			
400	41.6	61.9	110	172	283	2900	112	166			
420	42.6	63.4	113	177	290	3000	114	169			
440	43.6	64.9	115	181	296	3100	115	172			
460	44.6	66.3	118	185	303	3200	117	175			
480	45.6	67.8	120	189	310	3300	119	177			
500	46.5	69.2	123	193	316	3400	121	180			
520	47.4	70.5	125	196	322	3500	123	183			
540	48.3	71.9	128	200	328	3600	124	185			
560	49.2	73.2	130	204	334	3700	126	188			
580	50.1	74.5	132	208	340	3800	128	190			
600	51.0	75.8	135	211	346	3900	130	193			
620	51.8	77.0	137	215	352	4000	131	195			
640	52.6	78.3	139	218	358	4100	133	198			
660	53.4	79.5	141	221	363	4200	134	200			
680	54.3	80.7	143	225	369	4300	136	202			
700	55.0	81.8	145	228	374	4400	138	205			
720	55.8	83.0	147	231	379	4500	139	207			
740	56.6	84.2	150	235	385	4600	141	209			
760	57.4	85.3	152	238	390	4700	142	212			
780	58.1	86.4	154	241	395	4800	144	214			
800	58.8	87.5	156	244	400	4900	145	216			
820	59.6	88.6	157	247	405	5000	147	218			
840	60.3	89.7	159	250	410	5100	148	221			
860	61.0	90.7	161	253	415	5200	150	223			
880	61.7	91.8	163	256	419	5300	151	225			
900	62.4	92.8	165	259	424	5400	153	227			
920	63.1	93.8	167	262	429	5500	154	229			

Notes

- Differential Pressure (ΔP) equals inlet pressure (set pressure plus overpressure) at flowing conditions minus back pressure.
- See pages 12 and 13 for Minimum and Maximum Set Pressure Limits.
- To determine capacities on liquids other than water or for fluid temperatures other than 70°F, use the liquid sizing formula in the Crosby Engineering Handbook.
- The scope of the ASME Code, Section VIII, does not include pressures below 15 psig and therefore pressure relief valves set below 15 psig are not stamped with the ASME Code Symbol.

Capacity in U.S. gallons per minute of water at 70°F and 10% overpressure.

Capacities certified by the National Board of Boiler and Pressure Vessel Inspectors and in accordance with the ASME Boiler and Pressure Vessel Code, Section VIII.

Air Capacities Series 800* and Series 900 Valves - Metric Units

Air Capacities - Set Pressures 0.35-338 barg						
Set Press. [barg]	Effective Area [sq. mm.]					Set Press. [kPag]
	47.7	71	126	198	325	
	0.5 1 bar incr. ¹ 5 bar incr.	0.8	1.5	2.4	4.0	
	2.9	4.4	7.9	12.3	20.3	100 kPa incr. 500 kPa incr.
0.35	0.8	1.2				35
0.40	0.8	1.2	2.3			40
0.45	0.9	1.3	2.3			45
0.50	0.9	1.3	2.4	3.8	6.3	50
0.55	0.9	1.4	2.5	3.9	6.5	55
0.60	0.9	1.4	2.6	4.0	6.7	60
0.65	1.0	1.5	2.6	4.2	6.9	65
0.70	1.0	1.5	2.7	4.3	7.0	70
0.75	1.0	1.5	2.8	4.4	7.2	75
0.80	1.0	1.6	2.9	4.5	7.4	80
0.85	1.1	1.6	2.9	4.6	7.6	85
0.90	1.1	1.7	3.0	4.7	7.8	90
0.95	1.1	1.7	3.1	4.8	8.0	95
1	1.2	1.7	3.1	5.0	8.1	100
2	1.7	2.6	4.6	7.2	11.8	200
4	2.9	4.3	7.7	12.2	19.9	400
6	4.1	6.1	10.9	17.1	28.1	600
8	5.3	7.9	14.1	22.1	36.2	800
10	6.5	9.7	17.2	27.0	44.3	1000
12	7.7	11.4	20.4	32.0	52.4	1200
14	8.9	13.2	23.6	36.9	60.6	1400
16	10.1	15.0	26.7	41.9	68.7	1600
18	11.3	16.8	29.9	46.9	76.8	1800
20	12.5	18.5	33.1	51.8	84.9	2000
22	13.6	20.3	36.2	56.8	93.1	2200
24	14.8	22.1	39.4	61.7	101	2400
26	16.0	23.9	42.6	66.7	109	2600
28	17.2	25.6	45.7	71.7	117	2800
30	18.4	27.4	48.9	76.6	125	3000
32	19.6	29.2	52.1	81.6	133	3200
34	20.8	31.0	55.2	86.5	141	3400
36	22.0	32.7	58.4	91.5	149	3600
38	23.2	34.5	61.6	96.4	158	3800
40	24.4	36.3	64.7	101	166	4000
42	25.6	38.1	67.9	106	174	4200
44	26.8	39.9	71.1	111	182	4400
46	28.0	41.6	74.2	116	190	4600
48	29.2	43.4	77.4	121	198	4800
50	30.4	45.2	80.6	126	206	5000
52	31.6	47.0	83.7	131	214	5200
54	32.8	48.7	86.9	136	223	5400
56	34.0	50.5	90.0	141	231	5600
58	35.2	52.3	93.2	146	239	5800
60	36.4	54.1	96.4	151	247	6000
62	37.6	55.8	99.5	155	255	6200
64	38.7	57.6	102	160	263	6400
66	39.9	59.4	105	165	271	6600

Set Press. [barg]	Effective Area [sq. mm.]					Set Press. [kPag]
	47.7	71	126	198	325	
	0.5 1 bar incr. 5 bar incr.	0.8	1.5	2.4	4.0	
	2.9	4.4	7.9	12.3	20.3	100 kPa incr. 500 kPa incr.
68	41.1	61.2	109	170	279	6800
70	42.3	63.0	112	175	288	7000
76	45.9	68.3	121	190	312	7600
82	49.5	73.6	131	205	336	8200
88	53.1	78.9	140	220	361	8800
94	56.7	84.3	150	235	385	9400
100	60.3	89.6	159	250	409	10000
106	63.8	94.9	169			10600
112	67.4	100	178			11200
118	71.0	105	188			11800
124	74.6	110	197			12400
130	78.2	116	207			13000
136	81.8	121	216			13600
142	85.4	126	226			14200
148	88.9	132	235			14800
154	92.5	137	245			15400
160	96.1	142	254			16000
166	99.7	148	264			16600
172	103	153	273			17200
178	106	158				17800
184	110	164				18400
190	114	169				19000
196	117	174				19600
202	121	180				20200
208	124	185				20800
214	128	190				21400
220	132	196				22000
226	135	201				22600
232	139	206				23200
238	142	212				23800
244	146	217				24400
250	149	222				25000
256	153	228				25600
262	157	233				26200
268	160	238				26800
274	164	244				27400
280	167	249				28000
286	171	254				28600
292	175	260				29200
298	178	265				29800
304	182	270				30400
310	185	276				31000
316	189	281				31600
322	192	286				32200
328	196	292				32800
334	200	297				33400
338	202	301				33800

* Series 800 capacities are in blue screened area only.

Notes

- Not valid below 2.0 barg set pressure.
- Capacities below 2.0 barg set pressure are calculated at 0.2 bar overpressure.
- To determine capacities on gases other than air or vapors, for fluid temperatures other than 16°C, or if back pressure is specified, use the gas and vapor sizing formula in the Crosby Engineering Handbook.
- The scope of the ASME Code, Section VIII, does not include pressures below 1.0 barg and therefore pressure relief valves set below 1.0 barg are not stamped with the ASME Code Symbol.

Capacity in standard cubic meters of air per minute at 16°C and 10% overpressure. Valve discharging to atmospheric pressure.²

Capacities certified by the National Board of Boiler and Pressure Vessel Inspectors and in accordance with the ASME Boiler and Pressure Vessel Code, Section VIII.

Saturated Steam Capacities Unfired Pressure Vessel Service Series 800* and Series 900 Valves - Metric Units

Saturated Steam Capacities - Set Pressures 0.35-68 barg

Set Pressure [barg]	Effective Area [sq. mm.]					Set Pressure [kPag]
	47.7	71.0	126	198	325	
0.1 bar incr. ¹	2.6	3.9	7.1	11.1	18.2	10 kPa incr.
0.5 bar incr.	13.4	19.9	35.6	55.7	91.3	50 kPa incr.
0.35	37.5	55.8				35
0.40	39.1	58.1	103			40
0.45	40.5	60.2	107			45
0.50	41.8	62.2	110	173	284	50
0.55	43.1	64.2	114	179	293	55
0.60	44.4	66.0	117	184	302	60
0.65	45.7	67.9	121	189	310	65
0.70	46.9	69.7	124	194	319	70
0.75	48.1	71.5	127	199	327	75
0.80	49.3	73.4	130	204	335	80
0.85	50.6	75.2	134	209	344	85
0.90	51.8	77.0	137	215	352	90
0.95	53.0	78.8	140	220	360	95
1.0	54.2	80.6	143	225	368	100
1.5	66.4	98	176	275	452	150
2.0	78	116	208	325	533	200
3.0	105	156	279	437	716	300
4.0	132	196	350	548	899	400
5.0	159	236	421	660	1082	500
6.0	186	276	492	772	1265	600
7.0	212	316	564	883	1447	700
8.0	239	356	635	995	1630	800
9.0	266	396	706	1106	1813	900
10.0	293	436	777	1218	1996	1000
11.0	320	476	849	1329	2178	1100
12.0	347	516	920	1441	2361	1200
13.0	374	556	991	1552	2544	1300
14.0	401	596	1062	1664	2727	1400
15.0	428	636	1133	1776	2909	1500
16.0	454	676	1205	1887	3092	1600
17.0	481	716	1276	1999	3275	1700
18.0	508	756	1347	2110	3458	1800
19.0	535	796	1418	2222	3641	1900
20.0	562	836	1489	2333	3823	2000
21.0	589	876	1561	2445	4006	2100
22.0	616	916	1632	2556	4189	2200
23.0	643	956	1703	2668	4372	2300

Set Pressure [barg]	Effective Area [sq. mm.]					Set Pressure [kPag]
	47.7	71.0	126	198	325	
0.1 bar incr.	2.6	3.9	7.1	11.1	18.2	10 kPa incr.
0.5 bar incr.	13.4	19.9	35.6	55.7	91.3	50 kPa incr.
24.0	670	996	1774	2780	4554	2400
25.0	696	1036	1846	2891	4737	2500
26.0	723	1076	1917	3003	4920	2600
27.0	750	1115	1988	3114	5103	2700
28.0	777	1155	2059	3226	5285	2800
29.0	804	1195	2130	3337	5468	2900
30.0	831	1235	2202	3449	5651	3000
31.0	858	1275	2273	3560	5834	3100
32.0	885	1315	2344	3672	6017	3200
33.0	912	1355	2415	3783	6199	3300
34.0	938	1395	2487	3895	6382	3400
35.0	965	1435	2558	4007	6565	3500
36.0	992	1475	2629	4118	6748	3600
37.0	1019	1515	2700	4230	6930	3700
38.0	1046	1555	2771	4341	7113	3800
39.0	1073	1595	2843	4453	7296	3900
40.0	1100	1635	2914	4564	7479	4000
41.0	1127	1675	2985	4676	7661	4100
42.0	1154	1715	3056	4787	7844	4200
43.0	1180	1755	3127	4899	8027	4300
44.0	1207	1795	3199	5011	8210	4400
45.0	1234	1835	3270	5122	8392	4500
46.0	1261	1875	3341	5234	8575	4600
47.0	1288	1915	3412	5345	8758	4700
48.0	1315	1955	3484	5457	8941	4800
49.0	1342	1995	3555	5568	9124	4900
50.0	1369	2035	3626	5680	9306	5000
52.0	1422	2115	3768	5903	9672	5200
54.0	1476	2195	3911	6126	10037	5400
56.0	1530	2275	4053	6349	10403	5600
58.0	1584	2355	4196	6572	10768	5800
60.0	1638	2434	4338	6795	11134	6000
62.0	1691	2514	4481	7018	11500	6200
64.0	1745	2594	4623	7242	11865	6400
66.0	1799	2674	4766	7465	12231	6600
68.0	1853	2754	4908	7688	12596	6800

*Series 800 capacities are in blue screened area only.

Notes

- Not valid below 2.0 barg set pressure.
- Capacities below 2.0 barg set pressure are calculated at 0.2 bar overpressure.
- Maximum set pressure for steam service is 68.95 barg.
- To determine capacities on superheated steam or if back pressure is specified, use the steam sizing formula in the Crosby Engineering Handbook.
- The scope of the ASME Code, Section VIII, does not include pressures below 1.0 barg and therefore pressure relief valves set below 1.0 barg are not stamped with the ASME Code Symbol.

Capacity in kilograms per hour of steam at 10% overpressure. Valve discharging to atmospheric pressure.²

Capacities certified by the National Board of Boiler and Pressure Vessel Inspectors and in accordance with the ASME Boiler and Pressure Vessel Code, Section VIII.

Water Capacities Series 900 OMNI-TRIM® Valves - Metric Units

Water Capacities - Differential Pressures $\Delta P \leq 0.4-380 \text{ bar}^2$													
Diff. Pressure $\Delta P'$ [bar]	Effective Area [sq. mm]					Diff. Pressure $\Delta P'$ [kPa]	Diff. Pressure $\Delta P'$ [bar]	Effective Area [sq. mm]					Diff. Pressure $\Delta P'$ [kPa]
	47.7	70.1	126	198	325			47.7	70.1	126	198	325	
0.4	18.9	28.2	50.2			40	118	326	484	863	1352	2216	11800
0.6	23.2	34.5	61.5	96.4	158	60	124	334	496	885	1386	2272	12400
0.8	26.8	39.9	71.1	111	182	80	130	342	508	906			13000
1	30.0	44.6	79.5	124	204	100	136	350	520	927			13600
2	42.4	63.1	112	176	288	200	142	357	531	947			14200
4	60.0	89.2	159	249	408	400	148	365	542	967			14800
6	73.5	109	194	305	499	600	154	372	553	986			15400
8	84.9	126	224	352	577	800	160	379	564	1005			16000
10	94.9	141	251	393	645	1000	166	386	574	1024			16600
12	103.9	154	275	431	706	1200	172	393	585	1042			17200
14	112.3	166	297	465	763	1400	178	400	595	1060			17800
16	120.0	178	318	498	816	1600	184	407	605	1078			18400
18	127.3	189	337	528	865	1800	190	413	615				19000
20	134.2	199	355	556	912	2000	196	420	624				19600
22	140	209	372	584	957	2200	202	426	634				20200
24	147	218	389	610	999	2400	208	432	643				20800
26	153	227	405	635	1040	2600	214	439	652				21400
28	158	236	420	659	1079	2800	220	445	661				22000
30	164	244	435	682	1117	3000	226	451	670				22600
32	169	252	449	704	1154	3200	232	457	679				23200
34	175	260	463	726	1189	3400	238	463	688				23800
36	180	267	477	747	1224	3600	244	468	697				24400
38	185	275	490	767	1257	3800	250	474	705				25000
40	189	282	502	787	1290	4000	256	480	713				25600
42	194	289	515	807	1322	4200	262	485	722				26200
44	199	295	527	826	1353	4400	268	491	730				26800
46	203	302	539	844	1383	4600	274	496	738				27400
48	207	309	550	862	1413	4800	280	502	746				28000
50	212	315	562	880	1442	5000	286	507	754				28600
52	216	321	573	898	1471	5200	292	512	762				29200
54	220	327	584	915	1499	5400	298	518	770				29800
56	224	333	595	931	1526	5600	304	523	778				30400
58	228	339	605	948	1553	5800	310	528	785				31000
60	232	345	615	964	1580	6000	316	533	793				31600
62	236	351	626	980	1606	6200	322	538	800				32200
64	240	356	636	996	1632	6400	328	543	808				32800
66	243	362	645	1011	1657	6600	334	548	815				33400
68	247	367	655	1026	1682	6800	340	553	822				34000
70	251	373	665	1041	1707	7000	346	558	830				34600
76	261	389	693	1085	1778	7600	352	563	837				35200
82	271	404	719	1127	1847	8200	358	567	844				35800
88	281	418	745	1168	1914	8800	364	572	851				36400
94	291	432	770	1207	1978	9400	370	577	858				37000
100	300	446	795	1245	2040	10000	376	582	865				37600
106	309	459	818	1282	2100	10600	380	585	869				38000
112	317	472	841	1318	2159	11200							

Notes

- Differential Pressure (ΔP) equals inlet pressure (set pressure plus overpressure) at flowing conditions minus back pressure.
- See pages 14 and 15 for Minimum and Maximum Set Pressure Limits.
- To determine capacities on liquids other than water or for fluid temperatures other than 21°C, use the liquid sizing formula in the Crosby Engineering Handbook.
- The scope of the ASME Code, Section VIII,

does not include pressures below 1.0 barg and therefore pressure relief valves set below 1.0 barg are not stamped with the ASME Code Symbol.

Capacity in liters per minute of water at 21°C and 10% overpressure.

Capacities certified by the National Board of Boiler and Pressure Vessel Inspectors and in accordance with the ASME Boiler and Pressure Vessel Code, Section VIII.

Series 800 and Series 900 Pressure Relief Valve Configurations

Series 800

Series 900

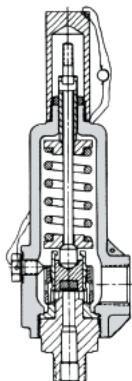

**Standard Threaded
MNPT x FNPT¹**

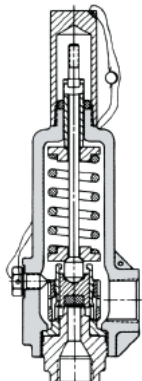

**Threaded
FNPT x FNPT¹**

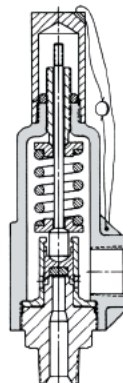

**Standard Threaded
MNPT x FNPT³**

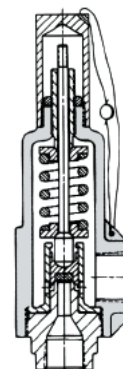

**Threaded
FNPT x FNPT³**
FNPT inlet not available
in No. 5 orifice.

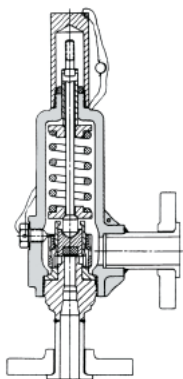

Flange x Flange²
Flanged connections available in
Nos. 6 and 7 orifices only.

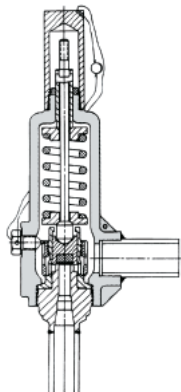

**Male SW x Male SW⁵
(Socket Weld)**

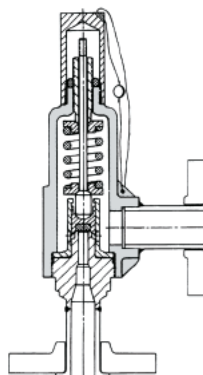

Flange x Flange⁴

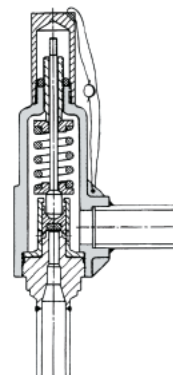

**Male SW x Male SW⁵
(Socket Weld)**

Notes

1. Dimensions, weights, and pressure/ temperature ratings are found on pages 10 and 12.
2. Dimensions, weights, and pressure/ temperature ratings are found on pages 11 and 13.
3. Dimensions, weights, and pressure/ temperature ratings are found on pages 14 and 16.
4. Dimensions, weights, and pressure/ temperature ratings are found on pages 15 and 17.
5. Contact factory for dimensions, weights, and pressure/temperature ratings.

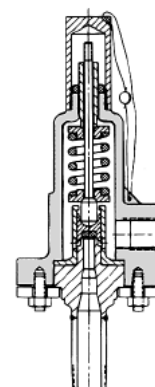

**Bolted Cylinder
MNPT x FNPT³**
Available in No. 5 orifice only.



www.tycoflowcontrol.com

Tyco Flow Control (TFC) provides the information herein in good faith but makes no representation as to its comprehensiveness or accuracy. This data sheet is intended only as a guide to TFC products and services. Individuals using this data sheet must exercise their independent judgment in evaluating product selection and determining product appropriateness for their particular purpose and system requirements. TFC MAKES NO REPRESENTATIONS OR WARRANTIES, EITHER EXPRESS OR IMPLIED, INCLUDING WITHOUT LIMITATION ANY WARRANTIES OF MERCHANTABILITY OR FITNESS FOR A PARTICULAR PURPOSE WITH RESPECT TO THE INFORMATION SET FORTH HEREIN OR THE PRODUCT(S) TO WHICH THE INFORMATION REFERS. ACCORDINGLY, TFC WILL NOT BE RESPONSIBLE FOR DAMAGES (OF ANY KIND OR NATURE, INCLUDING INCIDENTAL, INDIRECT, OR CONSEQUENTIAL DAMAGES) RESULTING FROM THE USE OF OR RELIANCE UPON THIS INFORMATION. Patents and Patents Pending in the U.S. and foreign countries. Tyco reserves the right to change product designs and specifications without notice.