

Conoflow



ITT Industries

Engineered for life

INSTRUCTION AND MAINTENANCE MANUAL GB50 Series Piston Actuator

These instructions should be read carefully before installation or maintenance.

This booklet describes the GB50 Series Piston Actuators. Actuators of various piston diameters and strokes or mounting arrangements other than shown here are available. Consult factory for complete information.

STANDARD MODELS

Series GB50XCA (figure 1)

Series GB51XCA/GB55XCA (figure 2)

Series GB52UC/GB53UC/GB54UC (figure 6)

Each model consists of an actuator assembly and integral positioner.

Series GB50XC (figure 1A)

Series GB51XC/GB55XC (figure 2A)

Each model consists of an actuator assembly, integral positioner, spacer bars and lower flange.

Series GB50XWA (figure 3)

Series GB51XWA/GB53XWA (figure 4A)

Series GB52UW/GB53UW/GB54UW (figure 6)

Each model consists of an actuator assembly only.

Series GB50XW (figure 3)

Series GB51XW/GB55XW (figure 2A)

Series GB54XW/GB55XW (figure 4A)

Each model consists of an actuator assembly only.

UNPACKING ACTUATOR

Check for accessory equipment packed with the actuator. Match all parts with items listed on packing list and record nameplate serial numbers. The actuator nameplate will provide necessary data required for complete identification. Always refer to model number when ordering spare parts, conversion parts, or accessory equipment.

INSTALLATION

The piston actuator can be mounted in any position. Regulator and gauge for loading one side of piston are mounted and piped. Air supply should be regulated and filtered.

Note: A Conoflow Airpak (filter-regulator) can be integrally mounted to provide constant regulation and filtration of air supply to the actuator.

WARNING

Conoflow's products are designed and manufactured using materials and workmanship required to meet all applicable industry standards. The use of these products should be confined to services specified and/or recommended in the Conoflow catalogs, instructions or by Conoflow application engineers (i.e. exceeding pressure temperature rating or using device for services other than those specified).

To avoid personal injury or equipment damage due to misuse or misapplication of a product, it is necessary to select the proper materials of construction and pressure temperature ratings which are consistent with performance requirements.

OPERATION

Normal range of the actuator positioner for full stroke is 3-15 PSI (21-103 kPa) (other ranges, including 3-9 PSI (21-62 kPa) and 9-15 PSI (62-103 kPa) are available). Connect the signal input to the connection marked "INST", on the positioner. Then connect a supply of clean, filtered air to the supply connection (see Piping Schematic, Positioner Instruction Manual*) to supply both the positioner and the cushion loading regulator. The supply pressure required is a function of the cylinder diameter and the force required. Air supply up to 100 PSI (690 kPa) can safely be used to insure a reserve of power and maximum speed. However, for economy of operation, use the lowest supply pressure with which satisfactory results can be obtained. The positioner has been tested and adjusted for operation with a supply pressure up to 100 PSI (690 kPa).

*Refer to Page 6 for Positioner Instruction Manual information.

ZERO ADJUSTMENT

To check zero adjustment (preset at factory), set the instrument output signal at the mid-point of its range (9 PSI (62 kPa) on a 3-15 PSI (21-103 kPa) range), turn zero adjustment coupling (figure 2) and note position of actuator stem. Continue rotation of zero adjustment coupling in proper direction until actuator stem is at the mid-point of stroke. Adjustment instrument out-put signal to low and high points in range and check the stem position at both ends of the stroke.

If stroke adjustment does not fall within specifications, refer to positioner manual for further instructions.

CUSHION LOADING REGULATOR

The cushion loading pressure has been arbitrarily set at approximately 20 PSI (138 kPa). This pressure may be adjusted by means of the cushion loading regulator when higher or lower return forces are required. The standard regulator supplied can provide settings up to 60 PSI (414 kPa) and as low as 5 PSI (35 kPa).

RANGE CHANGES

Standard range is 3-15 PSI (21-103 kPa). Other ranges are available, consult the factory.

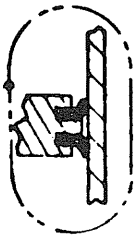

Figure 5 [Lipseal/Piston Arrangement]

MATERIALS OF CONSTRUCTION

Cylinder:	Aluminum
Piston:	Aluminum
Stem:	303 Stainless Steel
Lipseals:	Buna-N
Spacer Bars:	Steel
Yoke:	Ductile Iron (when required)

GB50	3"	(76 mm)	Piston Diameters
GB51	4"	(102 mm)	Piston Diameters
GB52	6"	(152 mm)	Piston Diameters
GB53	8"	(203 mm)	Piston Diameters
GB54	10"	(254 mm)	Piston Diameters
GB55	12.5"	(317.5 mm)	Piston Diameters

MAINTENANCE

POSITIONER

The positioner requires a minimum of maintenance. If servicing or replacements are necessary, refer to the appropriate Instructions and Parts List Booklets.

Refer to Page 6 for Positioner Instruction Manual information.

Disconnect actuator stem (11) from unit being serviced. Slide out piston (9) and actuator stem nut assembly (11). Lipseals (8) may now be inspected. Any water, dirt or sludge which may have accumulated inside the cylinder should be removed. "O"-ring (10) should be replaced each time by removing truarc ring (17) and retaining plate (16).

CYLINDER

Life of lipseals (8) is such that replacement will seldom be necessary under normal operating conditions. **Should disassembly become necessary the following procedure must be followed. Piston [9] should be in "up" position. Disconnect tubing and bleed air out of unit.** Remove cap from positioner (1) and spirolox ring directly under cap, so that positioner headplate can be lifted out. Loosen set screw and remove spring rod nut. Then remove six cap screws around positioner flange and lift positioner from headplate (12). Remove setscrews (7) and lift out cylinder headplate (12).

Before reassembling, apply a thin layer of grease (Dow-Corning #DC-33 light lubricant or equivalent) to inner wall of cylinder (14), actuator stem (11), lipseals (8) and the lipseal grooves in piston (9). Care should be exercised when inserting piston (9) into cylinder (14) because lipseal (8) flare is designed of a larger diameter than the cylinder bore. **If the piston will not enter the cylinder bore, run a shim [approximately .010" thick x 1/2" wide] between the lipseals and cylinder wall while applying slight pressure on the piston. [See figure 5].** Stem (11) should be carefully inserted through bearing (15) to prevent damage of bearing surface by thread of stem.

MAINTENANCE

POSITIONER

The positioner requires a minimum of maintenance. If servicing or replacements are necessary, refer to the appropriate Instructions and Parts List Booklets. Refer to Page 6 for Positioner Instruction Manual information.

CYLINDER

Life of lipseals (10) is such that replacement will seldom be necessary under normal operating conditions. **Should disassembly become necessary the following procedure must be followed. Piston (12) should be in "up" position. Disconnect tubing and bleed air out of unit. Remove cap from positioner (1) and spirolox ring directly under cap, so that positioner headplate can be lifted out. Loosen set screw and remove spring rod nut. Then remove six cap screws around positioner flange and lift positioner from headplate (9). Remove cover (2), spirolox retaining ring (3) and lift out cylinder headplate (9). Disconnect actuator**

stem (5) from unit being serviced. Slide out piston (12) and actuator stem assembly (5). Lipseals (10) may now be inspected. Any water, dirt or sludge which may have accumulated inside the cylinder should be removed. "O"-ring (7) should be replaced each time by removing truarc ring (8) and retaining plate (14).

Before reassembling, apply a thin layer of grease (Dow-Corning #DC-33 light lubricant or equivalent) to inner wall of cylinder (11), actuator stem (5), lipseals (10) and the lipseal grooves in piston (12). Care should be exercised when reinserting piston (12) into cylinder (11) because lipseal (10) flare is designed of a larger diameter than the cylinder bore. **If the piston will not enter the cylinder bore, run a shim [approximately .010" thick x 1/2" wide] between the lipseals and cylinder wall while applying slight pressure on the piston. [See figure 5]. Stem (5) should be carefully inserted through bearing (6) to prevent damage of bearing surface by thread of stem (5).**

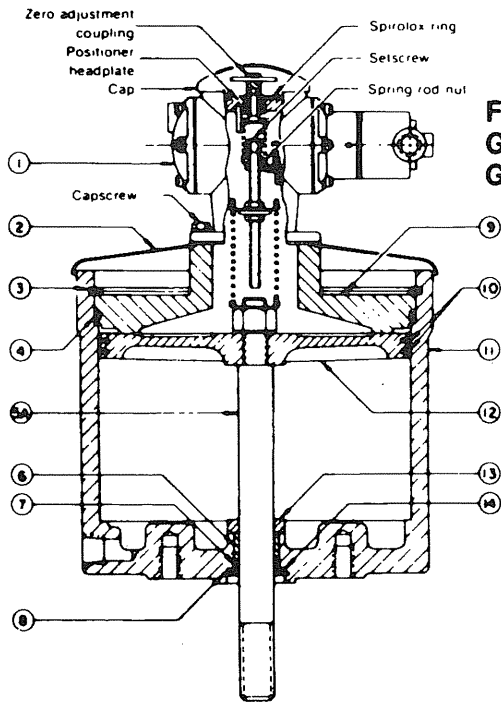

Figure 2
GB51XCA/
GB55XCA

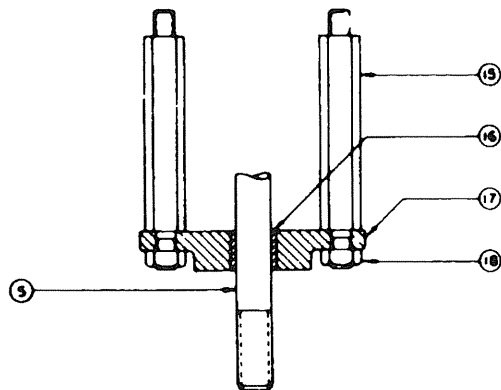

Figure 2A
GB51XC/XW
GB55XC/XW

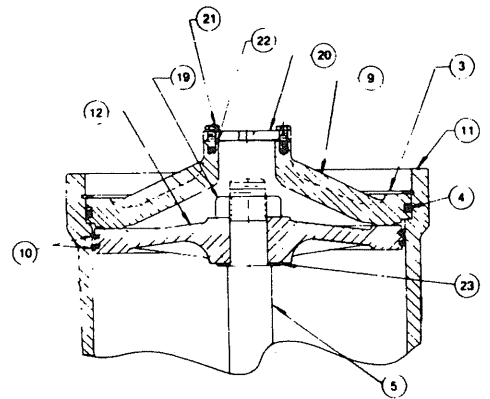

Figure 4A
GB51XW/XWA
GB55XW/XWA

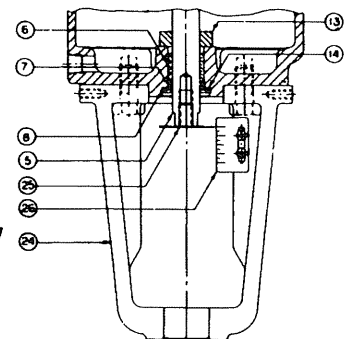

Figure 6
GB52/53/54UC
GB52/53/54UW

ITEM NO.	NO. REQ'D.	DESCRIPTION	B51 SERIES	B52 SERIES	B53 SERIES	B54 SERIES	B55 SERIES
1	1	Positioner	See pg. 6	See pg. 6	See pg. 6	See pg. 6	See pg. 6
2	1	Cover	6004105	6001812	6001994	6002240	6182521
3	1	Spirolox Ring	6004717	6004725	6004683	6190540	6004709
4	1	Headplate O-Ring (Note 1)	6077176	6077192	6077200	6077218	6077259
5 and 5A	1	Stem					
		B5_XCXW 1-1/8"(28.58mm)	—	6008676	—	—	—
		B5_XCA/XWA 1-1/8"(28.58mm)	—	6008759	—	—	—
		B5_XC/XW 1-1/2"(38.1mm)	—	—	6211098	—	—
		B5_XCA/XWA 1-1/2"(38.1mm)	—	—	6008924	—	—
		B5_XC/XW 2-1/2"(63.5mm)	—	—	—	6210157	—
		B5_XCA/XWA 2-1/2"(63.5mm)	—	—	—	6244198	—
		B5_XC/XW 3"(76.2mm)	6009419	—	—	—	—
		B5_XCA/XWA 3"(76.2mm)	6009427	—	—	—	—
		B5_XC/XW 4"(101.6mm)	6009443	6008668	6008833	6210132	6005474
		B5_XCA/XWA 4"(101.6mm)	6009450	6008676	6008825	6210140	—
		B5_XC/XW 6"(152.4mm)	—	6008726	6008858	—	—
		B5_XCA/XWA 6"(152.4mm)	—	6008718	6008841	—	—
		B5_XC/XW 8"(203.2mm)	—	—	6008866	—	—
		B5_XCA/XWA 8"(203.2mm)	—	—	6211080	—	—
		B5_XC/XW 10"(254mm)	—	—	6008882	6004576	—
B5_XCA/XWA 10"(254mm)	—	—	6008874	6004584	—		
		B52/53/54UC - UW	—	6002315	6231542	6002307	6002576
6	1	Oilite Bearing	6074595	6074736	6074652	6074694	6074710
7	1	Stem O-Ring (Note 1)	6076780	6077028	6077036	6077069	6077226
8	1	Truarc Ring	6075972	6075980	6075980	6076004	6076020
9	1	Headplate Throttling or On/Off	6009682	6001119	6001689	6002216	6005219
10	2	Lipseal (Note 1)	6004147	6004154	6004162	6004139	6210116
11	1	Cylinder					
		1-1/8" (28.58 mm)	—	6001788	—	—	—
		1-1/2" (38.1 mm)	—	—	6001796	—	—
		2-1/2" (63.5 mm)	—	—	—	6002182	—
		3" (76.2 mm)	6002521	—	—	—	—
		4" (101.6 mm)	6002570	6003826	6001747	6004345	6005193
		6" (152 mm)	—	6008817	6003537	—	—
		8" (203.2 mm)	—	—	6003453	—	—
10" (254 mm)	—	—	6210330	6006100	—		
12	1	Piston	6004360	6004386	6004402	6004428	6005235
13	1	Collar	See pg. 6	See pg. 6	See pg. 6	See pg. 6	See pg. 6
14	1	Retaining Plate	6023337	6009021	6009039	6002232	6005268
15	4	Spacer Bars					
		B5_XC/XW 1-1/8"(28.38mm)	—	6004816	—	—	—
		B5_XC/XW 1-1/2"(38.1mm)	—	—	6006134	—	—
		B5_XC/XW 2-1/2"(63.5mm)	—	—	—	6231500	—
		B5_XC/XW 3"(76.2mm)	6009278	—	—	—	—
		B5_XC/XW 4"(101.6mm)	6009310	6004766	6001564	6001564	6236723
		B5_XC/XW 6"(152.4mm)	—	6004774	6001598	—	—
		B5_XC/XW 8"(203.2mm)	—	—	6001606	—	—
B5_XC/XW 10"(254mm)	—	—	6001622	6001622	6005367		
16	1	Oilite Bearing	6074587	6074629	6074637	6074686	6074702
17	1	Lower Flange	6009252	6003529	6003503	6003511	6210231
18	4	Hex Jam Nut 1/2"-13NC (3/8"-16 NC -GB 51 only)	6900213	6900217	6900217	6900217	6900222
19	1	Locknut GB50XW/XWA Series	6002380	6002398	6002406	6002414	6005250
20	1	Plate	6002703	6002703	6002703	6002703	6002703
21	6	Hex Head Capscrew 1/4"-20x3/4"	6900096	6900096	6900096	6900096	6900096
22	1	Gasket	6001762	6001762	6001762	6001762	6001762
23	1	Ring	—	—	—	—	6005326
24	1	Yoke UC/UW Series	—	6029680	6028385	6028385	—
25	1	Indicator Disc UC/UW Series	—	6000608	6000616	6000624	6005364
26	1	Indicator Scale UC/UW Series	—	6002000	6001705	6002281	6007389

NOTES: 1. Recommended spare parts can be purchased individually or as a spare parts kit, under number

6385344	6385345	6385346	6385347	6385348
Spare Parts Kit	Spare Parts Kit	Spare Parts Kit	Spare Parts Kit	Spare Parts Kit
—B51	—B52	—B53	—B54	—B55
Consists of items 4, 7 & 10	Consists of items 4, 7 & 10	Consists of items 4, 7 & 10	Consists of items 4, 7 & 10	Consists of items 4, 7 & 10

2. Lower Flange (17)/Oilite Bearing (16)
Cylinder (11)/Oilite Bearing (6)
These parts are to be ordered as a matched set.

Collars	"A"
	032"
	062"
	.125"
	250"
	312"
	438"
	500"
	625"
	687"
	.718"
	906"
	1.000"
	1.062"
	1.500"
	1.531"
	1.750"
	1.937"
	2.000"
	2.093"
	3.000"

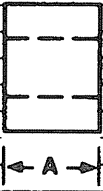

Instruction Manuals

Positioners

XR-XS- XT- XU	
J11-J12-J13-J14	C-8032 & C-8032A
XC-C31	C-8033
XH-C32	C-8034
XK-C33	C-8035
XV-C34	C-8036
XN-J21	C-8037
XP-J22	C-8037
P50/P51/P52	C-8038

Regulators

GH04	C-8025
GH20/H40	C-8015

Dimensional Drawings

Dimensional data for all GB5__ Series Actuators is contained on pages 7 and 9. For certified drawing requirements, refer to list below.

A6-41	GB50 ON-OFF	A7-114	GB51-GB55 w/GC31
A6-113	GB51-GB55 ON-OFF	A7-115	GB51-GB55 w/GC32
		A7-116	GB51-GB55 w/GC33
A7-100	GB52/53/54 w/Yoke	A7-117	GB51-GB55 w/GC34
A7-101	GB52/53/54 w/Yoke		
A7-102	GB52/53/54 w/Yoke	A50-4	Piping Schematic — J Positioner
A7-103	GB52/53/54 w/Yoke	A50-16	Piping Schematic — Full Reversal Positioner
		A50-48	Piping Schematic — Commandaire Positioner
A7-107	GB50 w/GC31		
A7-108	GB50 w/GC32		
A7-109	GB50 w/GC33		
A7-110	GB50 w/GC34		

MODEL GB50-PISTON ACTUATOR DIMENSIONS

GB50XCA Series

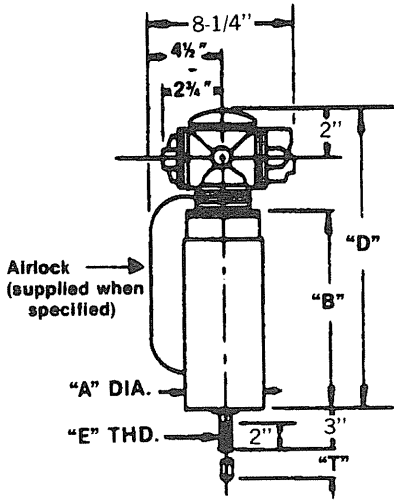

GB50XWA Series

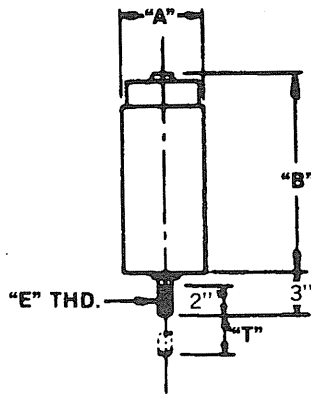

GB50XW Series

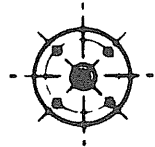
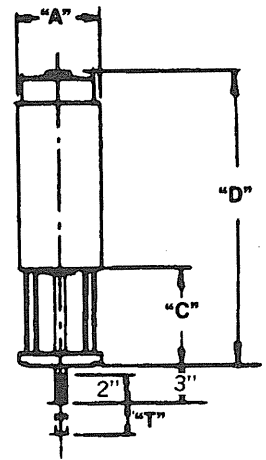

4 mtg. holes in base of cylinder "J" thd. "K" deep on "L" bolt circle.
Inverted plane view of mounting base for XC-A & XW-A models.

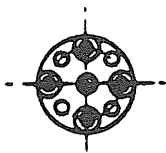

"F" mtg. bolts 4- "G" mtg. holes req'd for mtg. on "H" bolt circle.
Inverted plane view of mounting base for XC & XW models.

- NOTES:
1. For piping arrangements see A50-48
 2. Air connections 1/4 N.P.T.
 3. For complete positioner dims. see A50-49 through A50-52.

GB50XC Series

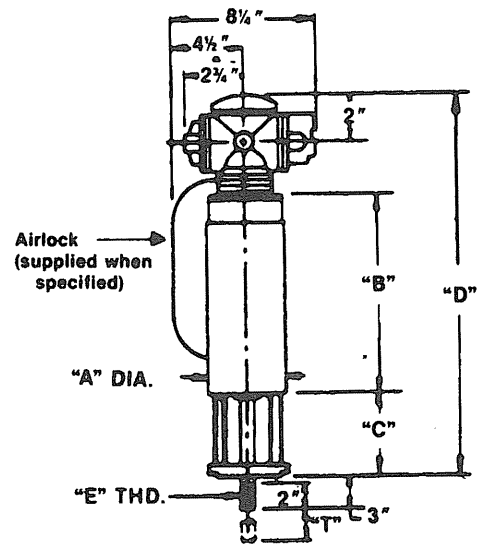

Millimeters = Dimension times (x) 25.4.

MODEL	Bore	A	B	C	D	E	F	G	H	J	K	L	M	T
GB50XC2	3"	3 1/2	6 1/8	3 3/4	13 15/16	1/2-20	5/16	11/32	2 3/4	—	—	—	5 1/4	2"
GB50XC5	3"	3 1/2	9 1/8	6 3/4	19 15/16	1/2-20	5/16	11/32	2 3/4	—	—	—	5 1/4	5"
GB50XC8	3"	3 1/2	12 1/8	9 3/4	25 15/16	1/2-20	5/16	11/32	2 3/4	—	—	—	5 1/4	8"
GB50XCA2	3"	3 1/2	6 1/8	—	10 3/16	1/2-20	—	—	—	5/16-18	1/2	2 3/4	5 1/4	2"
GB50XW2	3"	3 1/2	5	3 3/4	8 3/4	1/2-20	5/16	11/32	2 3/4	—	—	—	5 1/4	2"
GB50XW5	3"	3 1/2	8	6 3/4	14 3/4	1/2-20	5/16	11/32	2 3/4	—	—	—	5 1/4	5"
GB50XW8	3"	3 1/2	11	9 3/4	20 3/4	1/2-20	5/16	11/32	2 3/4	—	—	—	6 3/4	8"
GB50XWA2	3"	3 1/2	5	—	—	1/2-20	—	—	—	5/16-18	1/2	2 3/4	5 1/4	2"

SERIES GB51-GB55 PISTON ACTUATOR DIMENSIONS

GB51XCA/GB55XCA Series

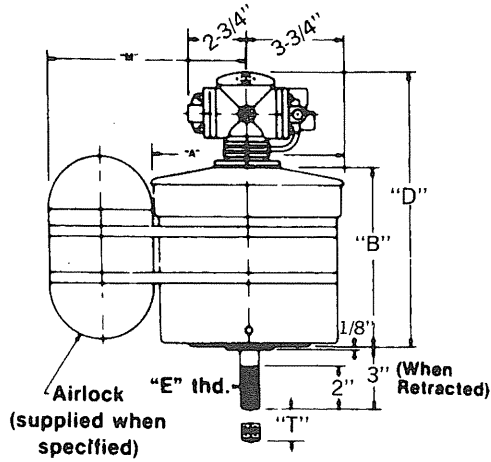

GB51XWA/GB55XWA Series

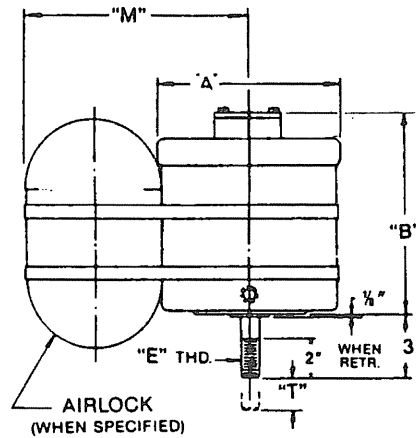

GB51XW/GB55XW Series

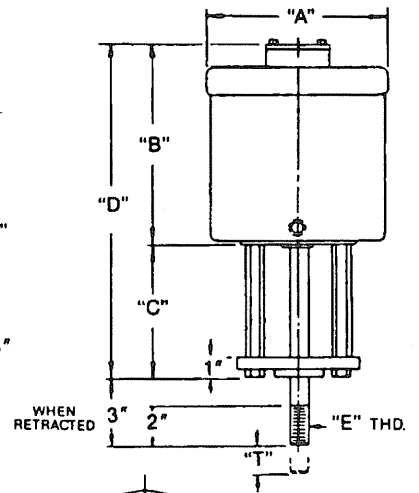

NOTE:

1. AIR CONNECTIONS 1/4" N.P.T.

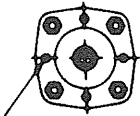
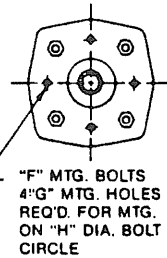
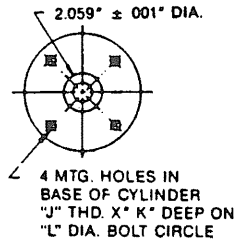

"F" mtg. bolts 4-"G" mtg. holes req'd for mtg. on "H" bolt circle.
Inverted plane view of mounting base for XC & XW series.

GB51XC/GB55XC Series

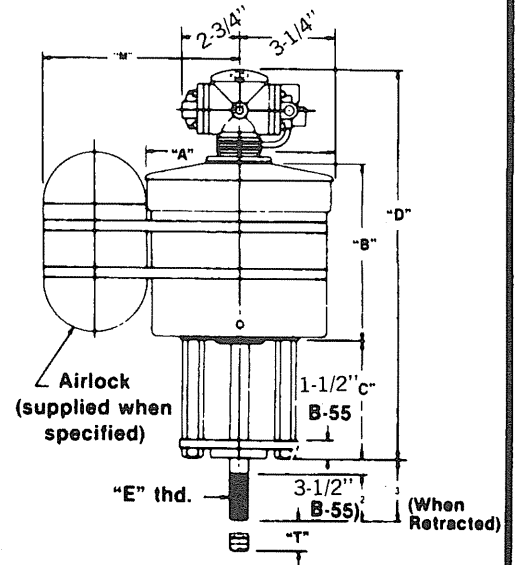

NOTES: 1. For piping arrangements see A50-48
2. Air connections 1/4" N.P.T.
3. For overall positioner dimensions see A50-49 through A50-52.

MODEL	BORE	A	B	C	D	E	F	G	H	J	K	L	M	T
B-51XC-3	4"	5-1/4	7-1/16	5	16-5/8	5/8-18	3/8	13/32	2-3/4	—	—	—	6	3"
B-51CX-4	4"	5-1/4	8-1/16	6	18-5/8	5/8-18	3/8	13/32	2-3/4	—	—	—	6	4"
B-51XC-A3	4"	5-1/4	7-1/16	—	11-5/8	5/8-18	—	—	—	3/8-16	1/2	3-1/4	6	3"
B-51XC-A4	4"	5-1/4	8-1/16	—	12-5/8	5/8-18	—	—	—	3/8-16	1/2	3-1/4	6	4"
B-51XW-3	4"	5	7-1/2	5	12-1/2	5/8-18	3/8	13/32	2-3/4	—	—	—	6	3"
B-51XW-4	4"	5	8-1/2	6	14-1/2	5/8-18	3/8	13/32	2-3/4	—	—	—	6	4"
B-51XW-A3	4"	5	7-1/2	—	—	5/8-18	—	—	—	3/8-16	1/2	3-1/4	6	3"
B-51XW-A4	4"	5	8-1/2	—	—	5/8-18	—	—	—	3/8-16	1/2	3-1/4	6	4"
B-52XC-1-1/8	6"	7-3/16	5-1/16	3-5/16	12-15/16	3/4-16	1/2	17/32	3-3/4	—	—	—	7	1-1/8"
B-52XC-4	6"	7-3/16	8-3/8	6	18-15/16	3/4-16	1/2	17/32	3-3/4	—	—	—	8-1/2	4"
B-52XC-6	6"	7-3/16	11-1/8	8	23-11/16	3/4-16	1/2	17/32	3-3/4	—	—	—	8-1/2	6"
B-52XC-A-1-1/8	6"	7-3/16	5-1/16	—	9-5/8	3/4-16	—	—	—	1/2-13	13/16	4-1/2	8-1/2	1-1-8"
B-52XC-A4	6"	7-3/16	8-3/8	—	12-15/16	3/4-16	—	—	—	1/2-13	13/16	4-1/2	8-1/2	4"
B-52XC-A6	6"	7-3/16	11-1/8	—	15-11/16	3/4-16	—	—	—	1/2-13	13/16	4-1/2	8-1/2	6"
B-52XW-1-1/8	6"	7	5-1/2	3-5/16	8-13/16	3/4-16	1/2	17/32	3-3/4	—	—	—	8-1/2	1-1/8"
B-52XW-4	6"	7	8-15/16	6	14-15/16	3/4-16	1/2	17/32	3-3/4	—	—	—	8-1/2	4"
B-52XW-6	6"	7	11-9/16	8	19-9/16	3/4-16	1/2	17/32	3-3/4	—	—	—	8-1/2	6"
B-52XW-A-1-1/8	6"	7	5-1/2	—	—	3/4-16	—	—	—	1/2-13	13/16	4-1/2	8-1/2	1-1/8"
B-52XW-A4	6"	7	8-15/16	—	—	3/4-16	—	—	—	1/2-13	13/16	4-1/2	8-1/2	4"
B-52XW-A6	6"	7	11-9/16	—	—	3/4-16	—	—	—	1/2-13	13/16	4-1/2	8-1/2	6"
B-53XC-1-1/2	8"	9-3/8	6-1/16	4	14-1/2	7/8-14	1/2	17/32	3-3/4	—	—	—	9-1/2	1-1/2"
B-53XC-4	8"	9-3/8	9-1/8	6	19-11/16	7/8-14	1/2	17/32	3-3/4	—	—	—	11-3/4	4"
B-53XC-6	8"	9-3/8	11-15/32	8	24-1/32	7/8-14	1/2	17/32	3-3/4	—	—	—	11-3/4	6"
B-53XC-8	8"	9-3/8	13-15/32	10	28-1/32	7/8-14	1/2	17/32	3-3/4	—	—	—	14-1/2	8"
B-53XC-10	8"	9-3/8	15-15/32	12	32-1/32	7/8-14	1/2	17/32	3-3/4	—	—	—	14-1/2	10"
B-53XC-A-1-1/2	8"	9-3/8	6-1/16	—	10-5/8	7/8-14	—	—	—	1/2-13	9/16	4-1/2	9-1/2	1-1/2"
B-53XC-A4	8"	9-3/8	9-1/8	—	13-11/32	7/8-14	—	—	—	1/2-13	13/16	4-1/2	11-3/4	4"
B-53XC-A6	8"	9-3/8	11-15/32	—	16-1/32	7/8-14	—	—	—	1/2-13	13/16	4-1/2	11-3/4	6"
B-53XC-A8	8"	9-3/8	13-15/32	—	18-1/32	7/8-14	—	—	—	1/2-13	13/16	4-1/2	14-1/2	8"
B-53XW-1-1/2	8"	9-1/8	6-3/8	4	10-3/8	7/8-14	1/2	17/32	3-3/4	—	—	—	9-1/2	1-1/2"
B-53XW-4	8"	9-1/8	9-17/32	6	15-7/32	7/8-14	1/2	17/32	3-3/4	—	—	—	11-3/4	4"
B-53XW-6	8"	9-1/8	11-25/32	8	19-25/32	7/8-14	1/2	17/32	3-3/4	—	—	—	11-3/4	6"
B-53XW-8	8"	9-1/8	13-25/32	10	23-25/32	7/8-14	1/2	17/32	3-3/4	—	—	—	14-1/2	8"
B-53XW-10	8"	9-1/8	15-25/32	12	27-25/32	7/8-14	1/2	17/32	3-3/4	—	—	—	14-1/2	10"
B-53XW-A-1-1/2	8"	9-1/8	6-3/8	—	—	7/8-14	—	—	—	1/2-13	9/16	4-1/2	9-1/2	1-1/2"
B-53XW-A4	8"	9-1/8	9-17/32	—	—	7/8-14	—	—	—	1/2-13	13/16	4-1/2	11-3/4	4"
B-53XW-A6	8"	9-1/8	11-25/32	—	—	7/8-14	—	—	—	1/2-13	13/16	4-1/2	11-3/4	6"
B-53XW-A8	8"	9-1/8	13-25/32	—	—	7/8-14	—	—	—	1/2-13	13/16	4-1/2	14-1/2	8"
B-54XC-4	10"	11-3/8	10-7/16	6	21	1-1/8-12	1/2	17/32	3-3/4	—	—	—	12-1/2	*4"
B-54XC-A4	10"	11-3/8	10-7/16	—	15	1-1/8-12	—	—	—	1/2-13	13/16	4-1/2	12-1/2	*4"
B-54XW-4	10"	11-3/8	11	6	17	1-1/8-12	1/2	17/32	3-3/4	—	—	—	12-1/2	*4"
B-54XW-A4	10"	11-3/8	11	—	—	1-1/8-12	—	—	—	1/2-13	13/16	4-1/2	12-1/2	*4"
B-55XC-4	12-1/2"	15	11-1/2	7-1/2	23-5/8	1-3/4-12	1	1-1/16	8	—	—	—	19-1/2	4"
B-55XW-4	12-1/2"	14-1/2	12-1/16	7-1/2	19-9/16	1-3/4-12	1	1-1/16	8	—	—	—	19-1/2	4"

*Maximum stroke for this unit is 5-3/8".

WARNING: MANUFACTURED WITH (1, 1, 1-TRICHLOROETHANE), A SUBSTANCE WHICH HARMS PUBLIC HEALTH AND ENVIRONMENT BY DESTROYING OZONE IN THE UPPER ATMOSPHERE.

Millimeters = Dimension times (x) 25.4.

Conoflow



ITT Industries

Engineered for life

P. O. Box 768
5154 Highway 78
St. George, SC 29477-0768
Telephone: (843) 563-9281
Fax: (843) 563-2131

e-mail: conoflow_info@fluids.ittind.com

world wide web: <http://www.ittconoflow.com>

**WARNING: MANUFACTURED WITH (1, 1, 1-TRICHLOROETHANE),
A SUBSTANCE WHICH HARMS PUBLIC HEALTH AND
ENVIRONMENT BY DESTROYING OZONE IN THE UP-
PER ATMOSPHERE.**