



PREMIER EZO AND PREMIER BODY ASSEMBLIES



INDEX

SECTION

DESCRIPTION AND SCOPE	I
INSTALLATION	II
General	II-A
Flow Direction	II-A5
Line bolting Material	II-A6
Alignment	II-B1
Disc Position	II-B2
Insulation	II-B4
MAINTENANCE	III
Premier EZO Lined Valve	
Assembly	III-C, -D & -E
Disassembly	III-B
Main Bearing Replacement	III-C
O-ring/Liner Assembly	III-D
Stem/Disc Assembly	III-E
Premier Unlined Valve	
Assembly	III-G & H
Disassembly	III-F
End Thrust Bearing	III-K
Main Bearings Replacement	III-G
Stem/Disc Assembly	III-H
Packing	
Adding Packing Rings	III-L
Replacement	III-J
PARTS ORDERING	IV
BODY ASSEMBLY DWGS.	Last Pages

PREMIER EZO ELASTOMER LINED

Standard construction includes 3", 4", 6", 8", 10" and 12" sizes. ANSI 125# or 150# and 300# bodies. In cast iron, cast steel or 316 SST. The disc of 316 SST is fastened to the 17-4PH SST stem with two taper pins. Flow direction is two-way. Seat leakage meets ANSI B16.104, Class VI. Liners and O-rings are Buna-N or EPDM. Working temperatures are 10° to 180°F for Buna-N and -30° to +250°F for EPDM. Maximum pressure drop is 150 psid in the closed position.

PREMIER UNLINED

The Premier is available without a liner in the same body materials and sizes as the Premier EZO, and provides shutoff to within 1% of the rated Cv. In the unlined version it is suitable for temperatures up to 500°F, and mates with ANSI 125# flat faced flanges and 150# or 300# raised face flanges. Stem sealing is provided by TFE asbestos packing with a packing follower, bushing and flange. Maximum pressure drops up to 300 psig. Stem bearing is 316 SST with TFE bore and the thrust bearing is TFE. Other materials are similar to those in the Premier EZO.



SECTION I

I. DESCRIPTION

This manual covers the body sub-assembly of the Cashco Premier and Premier EZO butterfly valves. Instructions for the pneumatic operated spring opposed diaphragm actuator, positioner and other accessories are included in IOM-48 or IOM-148.

The Cashco Premier EZO is an elastomer lined but-

terfly valve designed for throttling with a special liner that permits easy opening and eliminates most of the “pop open” flow surge common to most soft seat butterfly valves.

The Cashco Premier is an unlined butterfly valve designed for throttling and provides shut-off to within 1% of the rated Cv. The Premier (unlined) is suitable for temperatures up to 500°F.

SECTION II

II. INSTALLATION

A. General Guidelines:

1. It is recommended that the valve be mounted in the piping with the diaphragm actuator pointing up and with the valve body stem horizontal.
2. Clean the piping of all foreign material such as chips, scale, oil, grease and dirt, before installing the valve.
3. Working temperatures and working pressures for the Premier EZO and Premier are in Bulletin “PR-TB”.
4. Face-to-face dimensions are per MSS SP67.
5. Flow direction through the valve is two-way.
6. Line bolting material must comply with ANSI B16.34 and be compatible with the intended service.

B. Flangeless Body Installation:

The Premier EZO elastomer lined valve body is flangeless. Install between ANSI Class 150# and 300# raised face **weld neck** flanges, or their I.S.O. equivalent (PN 20 or 50). Do not use flange gaskets.

The Premier unlined valve body is flangeless. Install between ANSI Class 125# flat face flanges and 150# or 300# raised face flanges. Use flange gaskets.

1. Alignment:
 - a. When installing in a horizontal line, insert the lower flange studs between the flanges

first. This will support the valve while installing the rest of the studs. On a vertical line, the valve will be supported by the lower flange.

NOTE: *The valve must be centered on the flanges so the disc can fully open without contacting the flange or pipe bore.*

- b. The flanges must be parallel, in line and pulled up evenly against the valve's flange faces. Do not allow the valve to “cock” between the flanges.

2. Disc Position for Installation:

When installing the valve between flanges, the disc must be in the closed position.

CAUTION: ALL FAIL OPEN, air to close valves are shipped from the factory in the closed position. Valves not equipped with the handwheel assembly are mechanically held in the closed position. A slotted (“C”) washer is positioned on the push rod (10) between the lower case and the upper jam nut (43). See IOM-48 or IOM-148. It mechanically holds the valve closed. After installing the valve in the piping, remove the machine screws (36) and cover plate (20). Load the actuator to the recommended supply pressure and remove the slotted (“C”) washer. Depressurize the actuator and check for full valve travel. Reassemble nameplate and screws.

NOTE: *Save the slotted (“C”) washer and use when removing the valve from the piping. Reverse the procedures outlined in the preceding caution.*

3. Packing:

On the Premier (unlined) valve, be sure the packing flange nuts (22) haven't worked loose during shipment. Hand tighten the nuts when process pressure is applied to the valve. Tighten the nuts enough to stop leakage. **Do not over tighten.**

4. Insulation:

When installing insulation, insulate the valve body only. **Do not** insulate the integral extension bonnet as this could result in packing failure.

SECTION III

III. MAINTENANCE

A. General:

Cross sectional drawings with item numbers are included at the end of this manual.

For normal maintenance the Premier EZO and Premier can be disassembled and reassembled using standard shop tools.

B. Premier EZO Lined Valve Disassembly:

Refer to Premier EZO Assembly Dwg. for callouts used in the following steps.

1. Remove the complete valve assembly from the process piping.

NOTE: Close the disc before attempting to remove the valve from the piping. On ALL FAIL OPEN valves, refer to Installation, Section II-B2 for instructions on how the factory mechanically holds the valve closed. If the actuator has been removed from the body, rotate the stem/disc to close the valve. Confirm the position of the disc with the "V" groove mark on the actuator end of the stem. The "V" groove is parallel to the face of the disc.

2. Disconnect the valve from the actuator/arm housing. Refer to Actuator Maintenance Manual IOM-48 or IOM-148, Section V.
3. Remove the four cap screws (19) on 3" and 4" valves, or four nuts (22) on 6", 8", 10" and 12" valves.
4. Pull the yoke (12) and packing flange (5) off over the end of the stem. Remove O-ring (11) from extension bonnet.
5. Remove the taper pins (3.3). Grind off the smaller end of the pins flush with the disc

surface. With a flat faced punch, drive out the taper pins (3.3).

CAUTION: When driving the taper pins out, support the disc (3.1) to prevent damage to the main bearings (7, 8 & 9).

6. Remove the stem and disc (3.2 & 3.1). Twist the stem (3.2) and pull out the bonnet end.

CAUTION: The disc may drop out of the liner. Be careful not to damage the disc edge.

7. Press the liner (10) out of the body and remove O-rings (6) from the liner.
8. Remove the pipe plug (2) from the end of the body (1).
9. It is seldom necessary to replace the bearings (7, 8 and 9). If visual inspection of the stem (3.2) reveals excessive wear marks and/or deterioration, remove the bearings with the bearing ram. See Figure 1. Insert the bearing ram in the bonnet and press the main bearing(s) (7 & 8) out. Remove the ram and insert it through the pipe plug end of the body (1) and press main bearing (9) out.

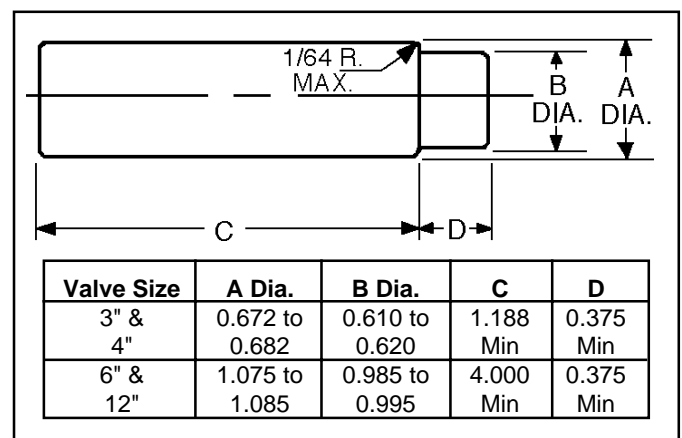

FIGURE 1
Bearing Ram

C. Installing the Main Bearings - Premier EZO:

1. Disassemble the valve in accordance with Section III-B.
2. Press the main bearing(s) (8,7) respectively, in the bonnet of the body and press the main bearing (9) in through the pipe plug end of the body.

NOTE: *The bearings must not protrude into the flow passage I.D. of the body as they will interfere with the liner.*

3. Install the O-rings (6) and liner (10) in accordance with Section III-D.

D. Installing O-rings and Liner - Premier EZO 3" and 4" valves: (For 6" through 12" valves see D.8.)

1. Inspect and clean all parts. Always use new O-rings (6).
2. Press the liner (10) into the body.

NOTE: *Position liner (10) such that the material code mark on the liner is located at the pipe plug end of the body (1). The specified location of the material code mark properly orients the step seat in the body (1). When viewed from the actuator end of the stem (3.2), clockwise rotation of the stem/disc closes the valve. Align the stem holes in the liner (10) with the holes in the body (1). Insert the stem (3.2) to ensure proper alignment.*

Code Mark	Liner Material
"N"	Buna-N
"E"	EPDM

3. To install O-rings (6) in the liner, insert the stem (3.2) in the pipe plug (2) end of the body (1) flush with the O-ring groove.

NOTE: *The stem (3.2) serves as the assembly stop for the O-ring (6) and ensures proper alignment of O-ring (6).*

4. Apply lubricant sparingly (silicone grease or equivalent) to the O-ring (6) and insert from bore of liner (10). Press O-ring (6) into the O-ring groove.
5. Remove the stem (3.2) from the plug end of the body (1) and insert in bonnet, flush with the O-ring groove.

6. Repeat Step 4.
7. Proceed to Section III-E.

8. 6", 8", 10" and 12" Valves:

Inspect and clean all parts. Always use new O-rings (6).

9. Apply lubricant sparingly (silicone grease or equivalent) to O-rings (6). Press O-rings (6) into the grooves.
10. Press the liner (10) into the body.

NOTE: *Position the liner (10) such that the material code mark on the liner is located at the pipe plug (2) end of the body (1). The specified location of the material code mark properly orients the step seat in the liner. When viewed from the actuator end of the stem (3.2), clockwise rotation of the stem/disc closes the valve. Align the stem holes in the liner (10) with the holes in the body (1). Insert the stem (3.2) to ensure proper alignment.*

Code Mark	Liner Material
"N"	Buna-N
"E"	EPDM

11. Proceed to Section III-E.

E. Stem/Disc Reassembly:

NOTE: *On factory supplied stem-disc kits the holes for the taper pins (3.3) are a matched set. Do not interchange with other components.*

1. Clean the pin holes in the stem (3.2) and disc (3.1) of all dirt, burrs, old Loctite¹, etc.
2. Place the disc (3.1) in the liner (10) (taper pin holes at actuator end). Insert the stem (3.2) through the body (1), liner (10) and disc (3.1), and align pin holes in the stem (3.2) and disc (3.1).

NOTE: *Align the punch mark on the disc (3.1) (near taper pin holes) with the punch mark on the end of the square section of the stem (3.2). The punch mark denotes the side to insert the taper pins (3.3).*

3. Spray Primer "T"², or equivalent, in pin holes. Let dry five minutes. Apply Loctite 601 in pin holes. Drive pins (3.3) into the holes with a hammer.

¹ Loctite - Trade name of Loctite Corp., Newington, CT

² Primer "T" - Trade name of Lotite Corp., Newington, CT

CAUTION: Support the disc (3.2) to prevent damage to the stem (3.1) or bearings (7,8 & 9).

TAPER PIN DETAILS FOR PREMIER VALVES

Valve Size (inches)	Shaft Diameter (inches)	American Std. Taper Pin Size	Drill Size
3, 4	5/8	2	18 (0.1695")
6, 8, 10 & 12	1	6	15/64"

NOTE: Always use new taper pins (3.3).

- Reassemble the valve following Steps 1 through 4, in reverse order, in Section III-B.
- Replace the pipe plug (2).

F. Premier Unlined Valve Disassembly:

Refer to Premier Unlined Assembly Dwg. for callouts used in the following steps.

- Remove the complete valve assembly from the process piping.

NOTE: Close the disc (3.1) before attempting to remove the valve from the piping. On **ALL FAIL OPEN** valves, refer to Installation, Section II-B2 for instructions on how the factory mechanically holds the valve closed. If the actuator has been disconnected from the body, rotate the stem/disc to close the valve. Confirm the position of the disc with the "V" groove mark on actuator end of the stem. The "V" groove is parallel to the face of the disc.

- Disconnect the valve from the actuator/arm housing. Refer to the Actuator Maintenance Manual IOM-48 or IOM-148, Section V.
- Remove two packing flange stud nuts (22) and two cap screws (19), on 3" and 4" valves, or four nuts (22), on 6", 8", 10" and 12" valves.
- Pull the yoke (12), packing flange (5), packing follower (16) and follower bushing (17) off over the end of the stem (3.2).
- Remove packing (13). Locate the cut in split rings and peel packing out.

NOTE: A set of packing consists of five rings.

- Remove the taper pins (3.3). Grind off the smaller end of the pins flush with the disc (3.1) surface. With a flat faced punch drive out the taper pins (3.3).

CAUTION: When driving the taper pins out (3.3), support the disc (3.2) to prevent damage to the main bearings (7).

- Remove the stem (3.2), end thrust bearing (14) and disc (3.1). Twist the stem (3.2) and pull out the bonnet end.

CAUTION: The disc (3.1) will drop out of the body (1). Be careful not to damage the stem (3.2) bearing surface of disc edge.

- Remove the upper sleeve (15).
- Remove the pipe plug (2).
- It is seldom necessary to replace the main bearings (7). If visual inspection of the stem (3.2) reveals excessive wear and/or deterioration, remove bearings (7) with the bearing ram. See Figure 1. Insert the ram from the body bore and with a long punch drive bearing(s) out through the bonnet. Remove the ram, insert it in the bearing at the pipe plug (2) end from within the body (1) bore and drive the bearing out.

G. Replacing Main Bearings:

- Disassemble the valve in accordance with Section III-F, Steps 1 through 10. Clean the bearing zones so new bearings can be installed without distortion or damage.
- Press the main bearing(s) (7) into the bonnet end of the body (1), all the way to the lip. Use the bearing ram of Figure III-B1. One bearing in 3" and 4", two bearings in 6"-12".

NOTE: The body stem bore is machined with two lips to prevent main bearings from protruding into the flow passage of the body.

- Press one main bearing (7) into the pipe plug (2) end of the body (1), all the way to the lip.
- Install the upper sleeve (15).
- Proceed to Section III-H.

H. Stem/Disc Reassembly:

NOTE: On factory supplied stem-disc kits the holes for the taper pins are a matched set. Do not interchange with other components.

1. Clean the pin holes in the stem (3.2) and disc (3.1) of all dirt, burrs, old Loctite, etc.
2. Place the disc (3.1) in the body (1) (taper pin holes at actuator end). Insert the stem (3.2) through the body (1), end thrust bearing (14) and disc (3.1), and align the pin holes in stem (3.2) and disc (3.1).

NOTE: Align the punch mark on the disc (3.1) (near taper pin holes) with the punch mark on the end of the square section of the stem (3.2). The punch mark denotes the side to insert the taper pins (3.3).

3. Always use new taper pins (3.3). See TAPER PIN DETAILS in Section III-E, step 3. Spray Primer "T", or equivalent, in pin holes. Let dry five minutes. Apply Loctite 601 in pin holes. Drive the pins (3.3) into the holes with a hammer.

CAUTION: Support the disc (3.1) to prevent damage to the stem (3.2) and bearings (7).

4. Proceed to Section III-J, steps 6, 7 and 8.

J. Replacing Packing on Premier:

COMPLETE VALVE with Actuator mounted on Body Assembly.

1. Depressurize valve.

CAUTION: The valve must be isolated from the process and vented before attempting further disassembly.

2. Remove packing flange nuts (22).
3. Slide the packing flange (5), packing follower (16) and follower bushing (17) away from the stuffing box.
4. Locate the cut in split rings and peel packing (13) out.

NOTE: A set of packing consists of 5 pieces.

5. Inspect the stem (3.2) and packing box bore to determine if additional disassembly for clean up or replacement is required. Refer to Section III-F for disassembly.

6. Slide one set (5 pieces) of packing rings (13) on the stem (3.2). Cuts in the packing rings (13) should be staggered 60° apart on adjacent rings.

7. Slide the packing follower (16) with follower bushing (17) and packing flange (5) in place.

NOTE: Packing follower must penetrate into the packing box.

8. Install the nuts (22) on the studs. Tighten the nuts finger tight.

NOTE: When valve is placed back in service, check to see that the packing is not leaking. Tighten the nuts evenly until leakage stops.

K. Replacing End Thrust Bearing:

1. Disassemble the valve in accordance with Section III-F, steps 1 through 6.
2. Pull the stem (3.2) out of the bonnet far enough to remove and replace the end thrust bearing (14).

CAUTION: The disc (3.1) will drop out of the body (1). Be careful not to damage the stem bearing surface or disc edge.

3. Reassemble the stem (3.2) and disc (3.1) in accordance with Section III-H, steps 1 through 3.

4. Reassemble the valve in accordance with Section III-F, steps 2 through 4, in reverse order.

L. Adding Packing Ring(s):

1. Proceed to steps 1, 2 and 3 of Section III.J.
2. Slide the packing ring(s) (13) on the stem (3.2). Cuts in the packing ring(s) (13) should be staggered 60° apart on adjacent ring(s).
3. Repeat steps 7 and 8 of Section III-J.

SECTION IV

IV. PARTS ORDERING INFORMATION

When ordering replacement parts, refer to parts list which was included with IOM's at time of shipment. Contact your Cashco Representative and give him the following information:

1. Serial number found on actuator nameplate.
2. Part name.
3. Complete 17-character part number.

PREMIER EZO 3" – 12" LINED BODY SUB-ASSEMBLIES

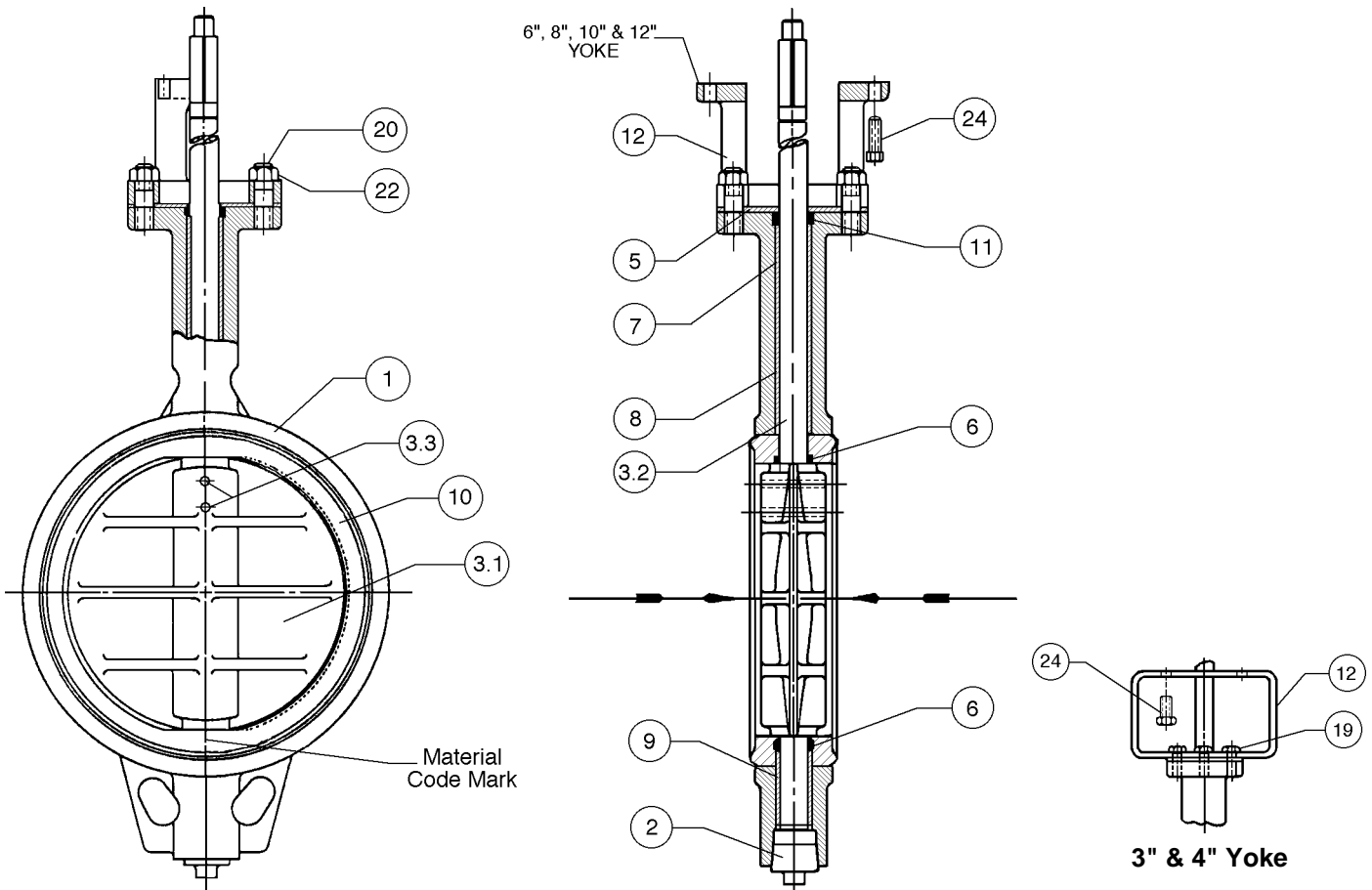

ITEM NO.	DESCRIPTION
1	Body
2	Pipe Plug
3	Disc / Stem Kit
3.1	Disc
3.2	Stem
3.3	Pin (Taper)
5	Packing Flange
6	O-Ring
7	Main Bearing

ITEM NO.	DESCRIPTION
8	Main Bearing
9	Main Bearing
10	Liner
11	O-Ring
12	Yoke
19	Cap Screw (3"-4")
20	Stud (Short) (6"-12")
22	Nut
24	Cap Screw (Mounting Body to Actuator)

PREMIER EZO 3" – 12" UNLINED BODY SUB-ASSEMBLIES

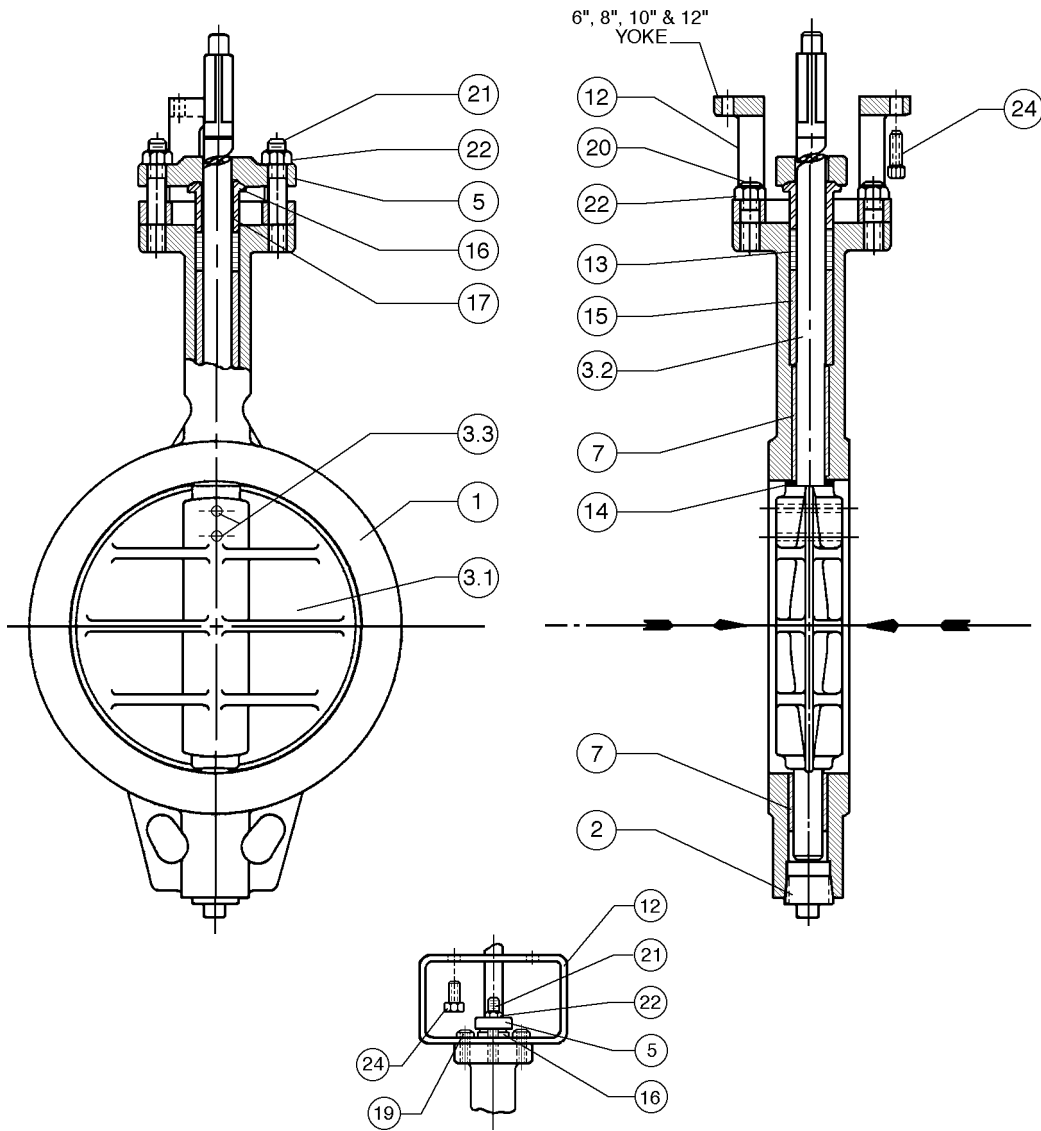

<u>ITEM NO.</u>	<u>DESCRIPTION</u>	<u>ITEM NO.</u>	<u>DESCRIPTION</u>
1	Body	14	Thrust Bearing
2	Pipe Plug	15	Upper Sleeve
3	Disc / Stem Kit	16	Packing Follower
3.1	Disc	17	Follower Bushing
3.2	Stem	19	Cap Screw (3"-4")
3.3	Pin (Taper)	20	Stud (Short) (6"-12")
5	Packing Flange	21	Stud (Packing Flange)
7	Main Bearing	22	Nut
12	Yoke	24	Cap Screw (Mounting Body to Actuator)
13	Packing		