



# MODEL 764P & 764PD PNEUMATIC PRESSURE CONTROLLERS

## SECTION I

### I. DESCRIPTION AND SCOPE

The Model 764P is a pressure controller used for sensing static pressure, and outputting a pneumatic signal proportional to the deviation from the setpoint.

The Model 764PD is a differential pressure controller used for sensing two static pressures (“HIGH” and “LOW”), and outputting a pneumatic signal proportional to the deviation from the setpoint.

With proper materials selection, the units are suitable for gaseous, liquid or steam service. Refer to Technical Bulletin 764P-TB for design conditions and selection recommendations.

Use of oxygen gas as the IAS for a 764P or 764PD is outside the scope of this IOM, and is considered “special construction”.

#### Abbreviations Utilized:

CCW – Counter Clockwise	P1 – Inlet Pressure	P/P – Pneumatic-to-Pneumatic
CW – Clockwise	P2 – Outlet Pressure	REV – Revolution or Reverse
DIR – Direct	PB – Proportional Band	SIG – Signal
EXH – Exhaust	PC – Pressure Controller	SRV – Safety Relief Valve
IAS – Instrument Air Supply	PCV – Pressure Control Valve	TR – Condensate Trap
	PI – Pressure Indicator	V – Vent

## SECTION II

### II. INSTALLATION

1. A block valve of the globe/needle type should be installed at the location of the pressure tapping. Ball, butterfly or gate valves are not recommended.
2. Recommended sensing tap pipe size is 1/2" (DN15).
3. Location of pressure sensing tap should be in a zone not subject to flow disturbances. Recommend a minimum of 10 pipe diameters upstream and 10 pipe diameters downstream from any elbow, tee, valve, etc. that disturbs flow.
4. A pressure gauge is recommended at the location of each tapping. Differential pressure designs may incorporate a differential pressure gauge.
5. A pigtail siphon is required for hot condensing fluids, such as steam, to assure a liquid trap at the controller. The siphon should be installed as near to the pressure connection(s) on the controller's diaphragm housing as practical.

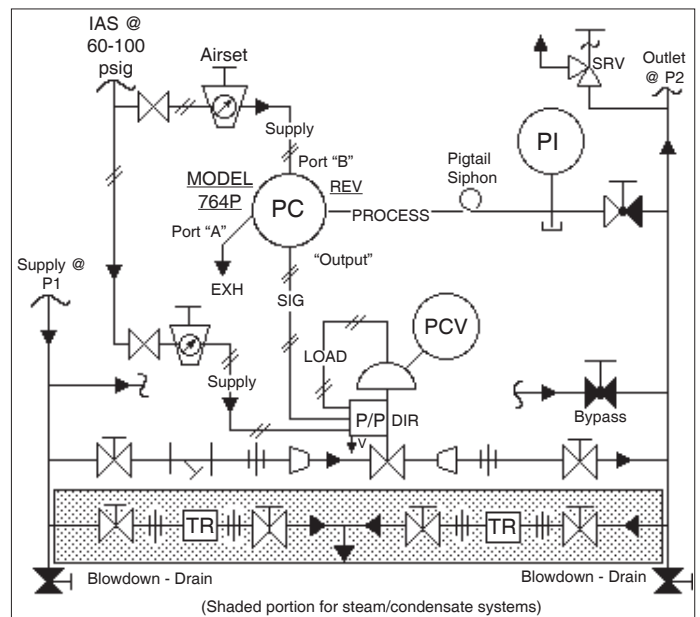
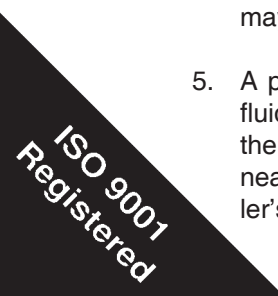

Figure 1: Recommended Piping Schematic for Pressure Reducing Control Valve with Positioner



6. It is recommended as a good practice to locate the controller as close as practical to the pressure tapping and at a similar elevation. For installations where the controller was factory mounted on a control valve unit, the pressure tapping should be within 6 - 10 feet (2 - 3 meters) of the control valve. (Remember to compensate for tappings located above the elevation of the controller for any liquid pressure head that may occur.)
7. The controller's pneumatic output signal (SIG) piping or tubing should be limited in length, and consideration must be given for the ultimate purpose of the SIG at its final destination. The following are recommended practices:

Purpose	Tubing	
	Size	Max Length*
SIG to Positioner	1.4" O.D.	100 ft.
SIG to Supply Booster	1.4" O.D.	100ft.
LOAD to Actuator	1.4" O.D.	10 - 12 ft.

\* Contact factory for longer lengths.

8. 764P controllers may be mounted by various methods:

**Bracket Mounted.** Includes a bracket with machine screws to allow attachment to a fixed structural appendage; requires specifying Option -23. (This is the method utilized when the 764P/PD is specified to be mounted to a control valve actuator.)

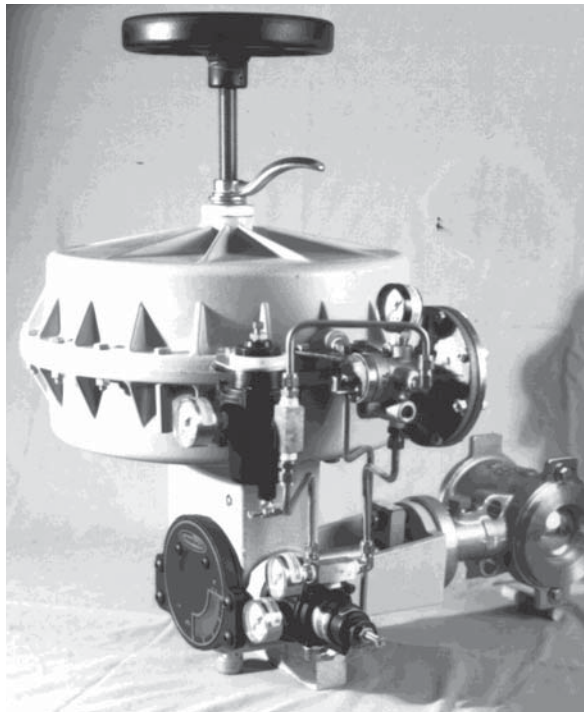

**Figure 2**

Factory Bracket Mounted to Ranger QCT Control Valve

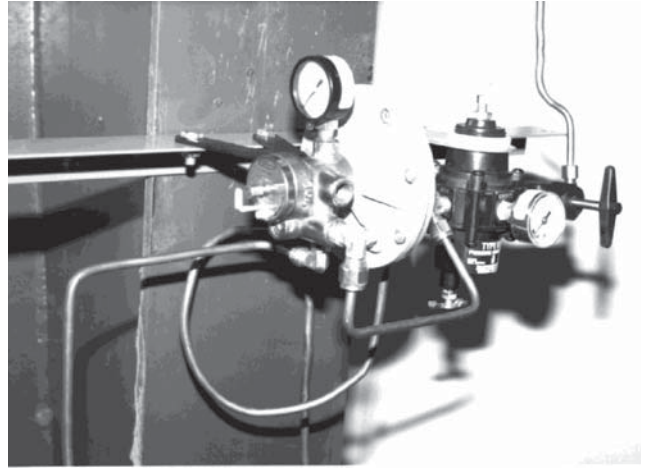

**Figure 3**

With Option -23; Field Bracket Mounting to Structure

**Field Pipe Nipple Mounted.** Recommend pipe tap on top or side of pipe.

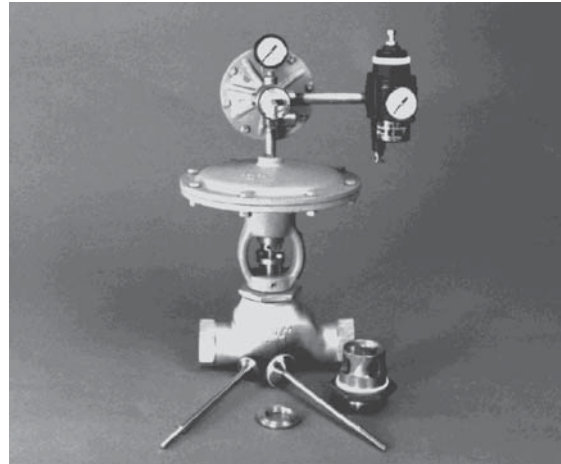

**Figure 4**

Output Pipe Nipple Mounted to Model 2266 Control Valve

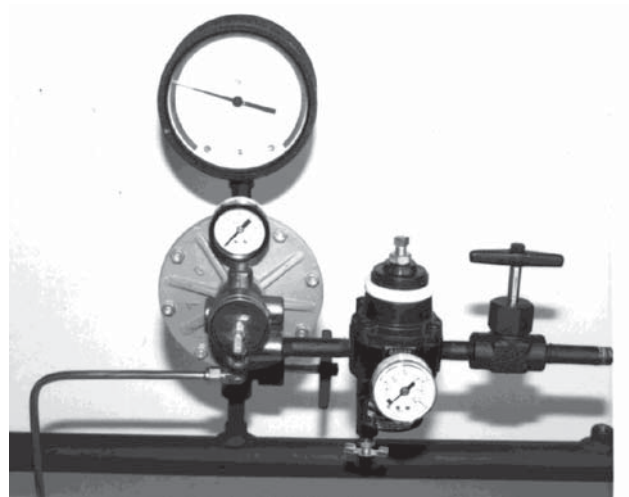

**Figure 5**

Field Pipe Nipple Mounted to Piping

**Panel Mounted.** Not factory provided. Requires field provision of a panel opening and support bracket per the below dimensions:

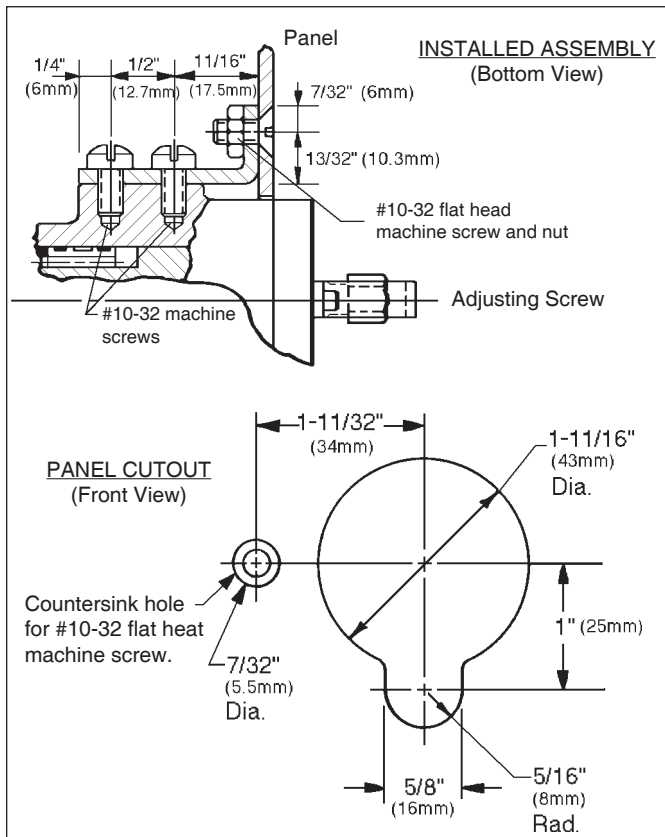

**Figure 6**  
Panel Mounted Assembly View

9. It is recommended that a 764PD be bracket or panel mounted. A 764PD can be pipe nipple mounted from 1/4" NPT connection.
10. Clean the piping and tubing of all foreign materials including chips, burrs, dirt, etc., prior to use. Use care in applying thread sealant or TFE tape to prevent excess material from entering the connecting pipe or tubing.
11. Controllers may be oriented in any position indoors. Outdoors, recommended locations are with the main longitudinal axis in a horizontal position, or with the pneumatic sensor head directed downwards. Exhibit care to assure rainwater is prevented from entering the unused exhaust port (Port A or Port B).
12. Connect piping/tubing per Tables 1 and 2.
13. 764P/PD's can operate with a lubricated, non-dried air supply. However, good practice and other system components (airsets, , relays, etc.) dictate use of the highest quality air supply available. If air can not be practically dried and bears oil, coalescing filters should be utilized to remove as

much oil and water as possible, as well as particles over 20 microns. Desiccant dried air is absolutely required for outdoor installations exposed to freezing temperatures.

14. For 764PD the system must be designed such that the "HIGH" pressure is always at a higher value than the "LOW" pressure is at the same time. If the expected HIGH and LOW pressures reverse with respect to each other, the unit will become inoperative, and the output will increase towards full IAS pressure of 18–20 psig (1.24–1.38 Barg).

TABLE 1		
Controller	<b>764P</b>	
	Action	
IAS to Port	<b>Direct</b>	<b>Reverse</b>
<b>A</b>	Supply	Exhaust
<b>B</b>	Exhaust	Supply
Process Pressures Above Atm. Pressure	Increase in pressure <u>Increases</u> output signal	Increase in pressure <u>Decreases</u> output signal
	<b>764PD</b>	
	Increase in differential pressure <u>Increases</u> output signal	Increase in differential pressure <u>Decreases</u> output signal
Controller	<b>764P</b>	
	Action	
IAS to Port	<b>Direct</b>	<b>Reverse</b>
<b>B</b>	Supply	Exhaust
<b>A</b>	Exhaust	Supply
Vacuum Process Below Atm. Pressure	Increase in vacuum <u>Increases</u> output signal	Increase in vacuum <u>Decreases</u> output signal
NOTE: 764PD cannot be utilized in vacuum service.		

TABLE 2		
Controller	Pressure Reducing Applications	
	Actions	
IAS to Port	Control Valve	Controller
<b>B *</b>	ATO-FC (REVERSE)	<u>Reverse-</u> Increase in pressure decreases output signal. Valve "fails closed".
<b>A</b>	ATC-FO (DIRECT)	<u>Direct-</u> Increase in pressure increases output signal. Valve "fails open".
	Back Pressure/Relief Applications	
	Actions	
<b>B *</b>	ATC-FO (DIRECT)	<u>Reverse-</u> Increase in pressure decreases output signal. Valve "fails open".
<b>A</b>	ATO-FC (REVERSE)	<u>Direct-</u> Increase in pressure increases output signal. Valve "fails closed".

\* Common applications       Uncommon applications

## SECTION III

### III. PRINCIPLE OF OPERATION

1. The 764 controllers employ laminar flow to produce the 3-15 psig (nominal 0.2-1.0 Barg) output signal. Laminar flow eliminates the need for range springs, levers, pivots and other parts that produce friction and lost motion.
2. The sensing diaphragm in the 764P and 764PD has a high spring rate and any change in the sensed pressure produces a minute diaphragm movement which strokes the sensor plate. The sensor plate, in turn, throttles the flow of instrument air through the sensor to develop the 3-15 psig (0.2-1.0 Barg) output signal.
3. On direct acting 764P controllers (see Figure 7) the supply air enters PORT A and passes through the proportional band restriction. With an increase in the controlled pressure the flow through the sensor is reduced which increases the output signal. The proportional band restriction regulates the flow rate of supply air into PORT A. PORT B is the exhaust port. A 764PD operates the same.
4. On reverse acting 764P controllers (see Figure 8) the supply enters PORT B (not PORT A). With an increase in the controlled pressure, the supply air flowing through the sensor decreases, which reduces the output signal. The proportional band restriction regulates the flow of exhaust through PORT A. A 764PD operates in a similar manner.

5. Closing (CW rotation) the proportional band adjusting screw reduces the proportional band. Opening the screw increases the proportional band.
6. The setpoint adjustment positions the sensor so the diaphragm must deflect its maximum for its highest controlled pressure setting and hardly deflects for the lowest controlled pressure setting.

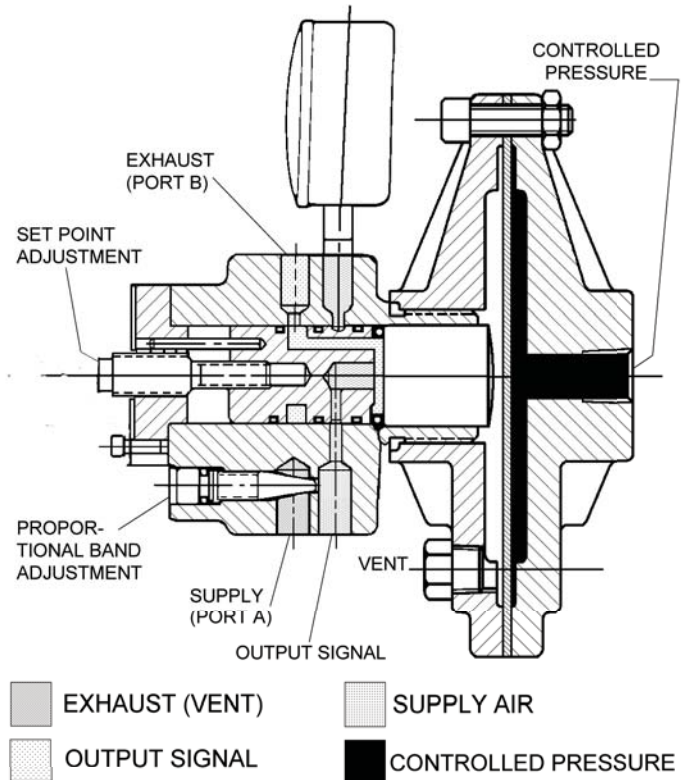

**Figure 7**  
Direct Action 764P

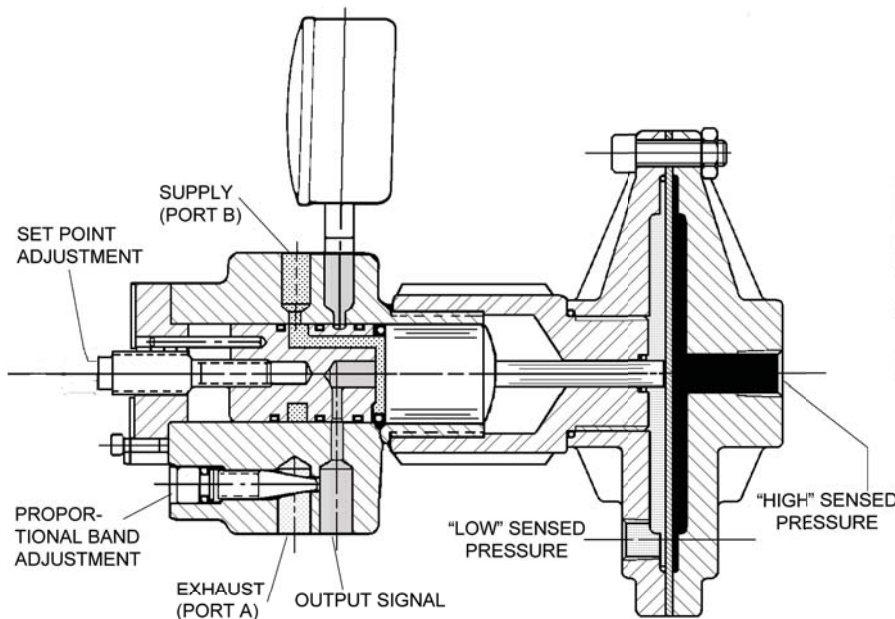

**Figure 8**  
Reverse Action 764PD

## SECTION IV

### IV. STARTUP

1. Prior to pressurizing through the airset, disconnect the instrument air supply (IAS) at the airset inlet, open the IAS block valve and blow the piping clear of any debris. Reconnect the piping and open the isolation valve. Set the airset to 18 psig (1.2 Barg).
2. The unit is shipped with the proportional band (PB) set at a minimum value of approximately 3 percent. Matchmarks are factory placed on the housing (1) and the PB needle valve (3) head approximately perpendicular to the screwdriver slot of the needle valve (3) head.
4. Start the process, observing the output gauge of the controller and the process pressure gauge. (For 764PD's, always pressure the HIGH pressure before the LOW pressure.) Assure that the output is changing (decreasing from 18 psig (1.2 Barg) if reverse acting, or increasing from 0 psig (0.0 Barg) is direct acting) as the controller approaches setpoint. Confirm proper action of control valve. Vary the process flow and observe the reaction of the controller to the disturbances.
5. If the controller seems to be "hunting" with overshoot and undershoot of setpoint, additional PB should be added. Rotate the needle valve (3) CCW in increments of 1/8 revolution. NOTE: When PB is adjusted, setpoint will normally require slight resetting; rotate the adjusting screw (2.3) as required. Repeat until best stability is obtained, or up to the maximum of 1-1/2 revolutions.



#### CAUTION

**Do not rotate the needle valve (3) CW beyond this location as the unit will be rendered inoperative. Rotate needle valve (3) CCW approximately 1/8 of a revolution increments at each adjustment. 1-1/2 revolutions are the maximum rotation available from the 3 percent minimum PB position to the 20% maximum PB position.**

3. Units are factory calibrated to approximately mid-range; i.e. 50-150 psig (3.4-10.3 Barg) range will have setpoint at approximately 100 psig (6.9 Barg). It is recommended that the unit be field calibrated following installation and prior to startup. (See Section VI. CALIBRATION for detailed procedure.) Adjust setpoint by rotating adjusting screw (2.3); turn CCW to decrease setpoint, or turn CW to increase setpoint.



#### CAUTION

**Always make adjustments in small increments and wait until reactions can be observed before making further adjustments.**

6. If "hunting" persists after completion of Step 5, the controller can be slowed down by reducing airset supply pressure down to 16 psig (1.1 Barg) in 1 psi (0.07 Bar) increments. If this procedure is used, repeat Step 5.
7. If "hunting" persists after completion of Step 6, rotate the needle valve on the sensing line "towards closed" to provide "snubbing" action. **DO NOT FULLY CLOSE SENSING NEEDLE VALVE!**

## SECTION V

### V. MAINTENANCE

#### A. General:

1. Refer to Figure 12 for basic pressure controller. Refer to Figure 13 for differential pressure controller.
2. Maintenance procedures hereinafter are based on removal from the process piping system where installed. When removing the tubing, put a tag on the tubing which port, "A" or "B", was utilized.

3. If complete overhaul is undertaken, it is recommended that the pneumatic circuit overhaul be completed prior to diaphragm replacement.
4. Lightly grease all sensor sub-assembly (2) O-rings (5) (6) upon replacement with lithium grease; cloth wipe all excess grease.

#### B. Diaphragm Replacement:

1. If diaphragm (12) has cracked and leaked, complete unit must be overhauled including the pneumatic circuit portion.

2. Remove cap screws (19) and nuts (18). Remove diaphragm upper case (13) and upper diaphragm O-ring (16). Remove diaphragm (12), and SST diaphragm cover (17) if supplied. Remove lower case diaphragm O-ring (16) and pusher post O-ring (23) for 764PD. Inspect for any corrosion damage and/or permanent deformation of the diaphragm (12) and diaphragm cover (17); if bent, replace.
3. For 764PD, separate at the screwed joint between the diaphragm lower case (14) and the adapter (21) turning the diaphragm case (14) CCW (viewed from diaphragm case end). When separated, remove the adapter O-ring (22) and replace. Reinstall the adapter (21) and diaphragm lower case (14).
4. For the 764PD, replace diaphragm O-ring (16) for the lower case (14) and the pusher post O-ring (23).
5. Replace diaphragm (12) and diaphragm cover(s) (17), if supplied. Assure that the diaphragm cover (thin SST material) (17) is placed on side(s) exposed to the process fluid(s). (764PD requires both sides to be covered, if supplied with diaphragm covers (17).
6. Replace with new upper case diaphragm O-ring (16), upper case (13), and cap screws with nuts (19 and 18).
7. Recalibrate per Section VI.

**C. Pneumatic Circuit Overhaul:**

1. Remove output pressure gauge (11) and test calibration. If gauge is off  $\pm 2$  psi ( $\pm 0.14$  Bar) recommend replacement.
2. Remove lower diaphragm case (14) from the pneumatic housing (1) at the point where screwed together. Rotate the diaphragm case (14) CCW (viewed from diaphragm case end) to loosen. For 764PD: Remove adapter (21) together with lower diaphragm casing (14) at the screwed joint between the pneumatic housing (1) and the adapter (21). Rotate the adapter (21) CCW (viewed from diaphragm case end) to loosen. Once loosened, orient the unit along a horizontal axis to prevent internal parts from falling from within when separated. **DO NOT REMOVE PUSHER-POST (24) FROM 764PD.**
3. Remove sensor plate (15.1) (15).
4. Remove nameplate screw (9), nameplate (10), and four housing screws (8). Grasp the sensor

sub-assembly (2) end plate (2.2), and pull it outwards from the housing (1). Watch for the sensor pin (2.4) as the sensor sub-assembly (2) is withdrawn, as pin (2.4) easily falls out and could be lost.

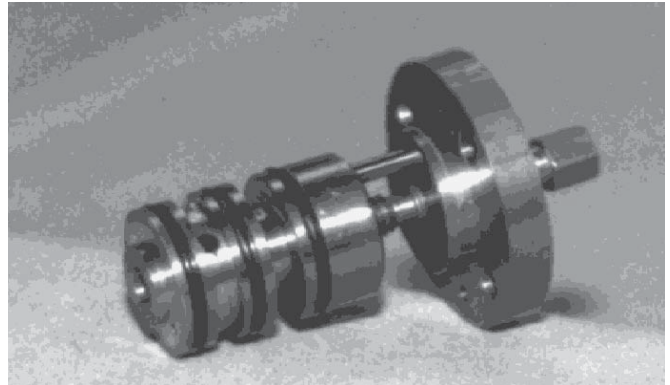

**Figure 9:** Sensor Sub-Assembly (2)

5. Remove sensor plate O-ring (6).
6. Take note of the position of the PB needle valve (3) by rotating it CW until it seats: count the exact amount of rotation in 1/8 rev. increments; record the count in Table 3. Remove the PB needle valve (3) with O-ring (7) by rotating CCW. Remove O-ring (7).

TABLE 3		
Part	DESCRIPTION OF ROTATION	NO. OF REVOLUTIONS
PB Needle Valve (3)	No. of Revolutions rotated CW to fully seat	

7. Remove the three sensor O-rings (5) from the sensor (2.1).
 

**NOTE:** Typically, additional dis-assembly of the sensor sub-assembly (2) is not required. If it is necessary to replace any of the sensor sub-assembly parts (2.1, 2.2, 2.3, 2.4, 2.5) a complete new sensor sub-assembly must be installed. Contact the factory for assistance.
8. Take all the metal parts except the gauge (11) and nameplate (10) and clean in suitable solvent. Clean and air blow all drilled air passages.
9. Install pressure gauge (11) into the pneumatic housing (1) using suitable thread sealant.
10. Install new O-rings (5) on sensor sub-assembly (2). Check the two dimensions given in Figure 10 of the sensor sub-assembly as “final settings”.

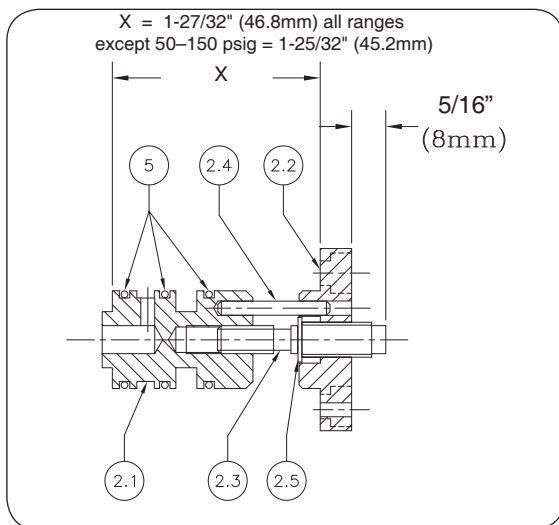

**Figure 10**  
Sensor Sub-Assembly  
Assemble per these Dimensions

11. Slide the sensor sub-assembly (2) back into the housing (1) so as not to damage the sensor O-rings (5). The final position should have the sensor pin (2.4) directly above the center of the adjusting screw (2.3). Install the four end plate screws (8). See Figure 11.

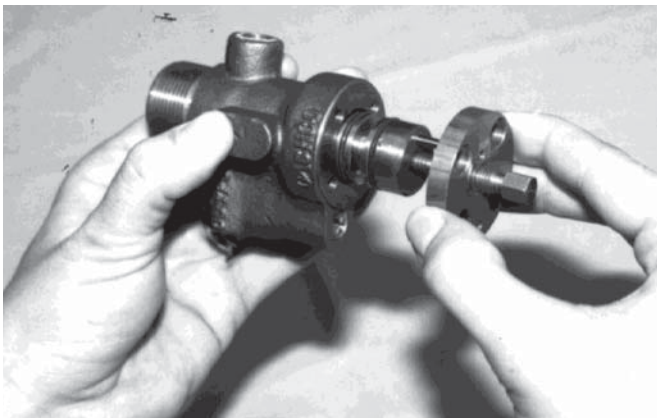

**Figure 11**

12. Install the nameplate (10) and nameplate screw (9).
13. Install the PB needle valve (3) with a new O-ring (7). Screw the needle valve (3) CW until seated, then back out to same position recorded in Table 3 prior to disassembly.
14. Place a new sensor plate O-ring (6) down into the housing (1) cavity next to the end of the sensor (2.1). Slide the sensor plate (15) into the housing (1); the flat portion of the sensor plate (15) should seat against the O-ring (6).

The rounded end of the sensor plate (15) will touch the diaphragm (16) for the 764P, or the pusher post (24) of the 764PD.

**NOTE:** The previous description is for 764PD's and 764P's in pressure ranges 2" - 30" Hg, 1-30 psig, 20-100 psig, 50-150 psig and 90-500 psig; it is also for 764PD's for differential pressure ranges 1-30, 20-100 and 50-150 psid. Refer to Figure 12 "Diaphragm Sub-Assembly for 450-2500 psig". Observe that the sensor plate (15) consists of a four part sub-assembly as follows:

- 15.1 Sensor Plate
- 15.2 Adaptor
- 15.3 Retaining Ring
- 15.4 Spring

17. Re-engage the pneumatic housing (1) to the diaphragm lower case (14) of the 764P, or the adaptor (21) of the 764PD; rotate CW. Wrench tighten.
18. Calibrate per Section VI.

## SECTION VI

### VI. SHOP CALIBRATION

1. Install a 1/4" pipe plug in the "OUTPUT" port of unit.
2. Provide an 18 psig (1.2 Barg) IAS to the proper port as determined by Table 1, Section II.
3. Leave PB as set in Section V.C.13. If this setting is unknown, rotate the PB needle valve (3) CW until seated. Rotate needed valve (3) CCW until "indented matchmarks" align; this is approximately 1/8–1/4 of a revolution.
- 4.1. Provide a known pressure (compressed nitrogen, etc.) equal to the desired setpoint to the diaphragm "PROCESS" connection for the 764P.
- 4.2. For the 764PD, place a known static pressure equal to the desired differential pressure setpoint to the "HIGH" process connection; leave the "LOW" process connection vented to atmosphere.

- 5.1. **FOR DIRECT ACTION:** If the output pressure gauge is at/near 15 psig (1.03 Barg) increase the setpoint by rotating the adjusting screw (2.3) CW until the output decreases to 9 psig (0.62 Barg)

If the output pressure gauge is at/near 0 psig (0.0 Barg) decrease the setpoint by rotating the adjusting screw (2.3) CCW until the output rises to 9 psig (0.62 Barg).

- 5.2. **FOR REVERSE ACTION:** If the output pressure gauge is at/near 15 psig (1.03 Barg) decrease the setpoint by rotating the adjusting screw (2.3) CCW until the output decreases to 9 psig (0.62 Barg).

If the output pressure gauge is at/near 0 psig (0.0 Barg) increase the setpoint by rotating the adjusting screw (2.3) CW until the output rises to 9 psig (0.62 Barg).

**NOTE:** *If the unit cannot be shop calibrated to either the upper or lower value of the stated range, refer to statement in VII.7.A. for recommendation. Repeat shop calibration.*

## SECTION VII

### VII. TROUBLE SHOOTING GUIDE

1. No controller response

Possible Cause	Remedy
A. No air supply.	A1. Check to see if air is available at airset. A2. Check to see if airset filter and/or dripwell is plugged.
B. Improper action; port "A" or "B" connections reversed.	B. Reference Tables 1 & 2 herein for desired action and proper port; reverse as required.
C. Check process isolation valve and line to see if open and/or clear.	C1. Open block needle valve on process. C2. Disconnect piping/tubing at both ends, blow to determine if obstructed. Carefully blow needle valve to clear obstruction; use caution commensurate with fluid handled in accordance with Owner's procedures.
D. Improper pressure tap location.	D. For relief applications, tapping is upstream; for reducing applications tapping is downstream of the control valve.
E. PB needle valve is fully closed.	E. Open at least to alignment of matchmarks on valve's screw head and housing.
F. Ice formation.	F. Use dry air as an IAS medium in cold weather. Thaw as necessary by use of air heater. Trace as necessary.
G. Final element operation problem; i.e. control valve, positioner, solenoid, etc.	G. Reference instructions for operation of final element.

2. Improper control valve action.

Possible Cause	Remedy
A. Mismatch of pneumatic hardware.	A. Check bench set of actuator. Consider positioner or booster.
B. Improper action; port "A" or "B" connections are reversed.	B. Reference Tables 1 and 2 herein for desired action and proper port; reverse as required.

3. Erratic Operation; Rapid Cycling.

Possible Cause	Remedy
A. Insufficient PB	A. Increase PB in 1/8 rev. increments by turning the needle valve CCW. Reset setpoint as required (Max PB at 1-1/2 revs.).
B. Improper air supply.	B1. Supply pressure too high. Reduce airset output supply pressure to 15-18 psig. B2. Air supply unsteady. Replace airset.
C. Pulsing process sensing.	C1. Snub process needle valve as far as practical without shutting off. Observe process gauges carefully. C2. Poor location of process pressure tap. Evaluate and consider relocation.
D. Non-Correctible process dynamics.	D1. Bypass control valve positioner and directly load actuator. D2. Review sizing of control valve, may be oversized. Use restricted trim if necessary. D3. Consult factory

4. Sluggish operation; slow action.

Possible Cause	Remedy
A. Restricted flow(s).	A1. Open process needle valve adequately. Disconnect tubing and blow sensing line. A2. Check equivalent output tubing line length against those indicated herein in Section 11.7. Relocate controller, or consider adding an air booster or positioner at the control valve. A3. Check for mashed or pinched tubing. A4. Installation debris. Air blow line. A5. Ice in lines. Use dry air supply.
B. Insufficient air supply.	B. Increase supply up to 18-20 psig.
C. Too much PB.	C. Decrease PB in 1/8 rev. increments. Reset setpoint as required.
D. Improper range selection.	D. Use the lowest range possible, if available to obtain the best response.
E. Too large actuator.	E. Add an air booster or positioner at the actuator.
F. Use of alcohols, glycols in freezing weather; dissolved lubricant on O-rings.	F. Remove sensor sub-assembly and lubricate O-rings.

5. Calibration Erratic; frequent setpoint adjustments.

Possible Cause	Remedy
A. Sensing diaphragm loose at screwed connection to housing or adapter.	A. Piping weight is cantilevered off of process connections or instrument air connections causing unscrewing, and effecting internal clearances. Change piping or add supports as required.
B. Bent sensing diaphragm.	B. Inspect diaphragm; replace if bent. Bent diaphragm indicates an overpressure condition; correct if necessary.
C. Air supply debris.	C1. Provide a cleaner air supply or piping source. C2. Ice in lines. Correct as necessary.

6. Leakage of process fluid.

Possible Cause	Remedy
A. Sensing diaphragm O-ring failure.	A1. Improper installation causing overheating by not providing a loop seal for hot condensing fluids; i.e. steam. A2. Chemical attack. Consult factory.
B. For 764PD, pusher post O-ring failure.	B1. Same as A1. above. B2. Same as A2. above.
C. Diaphragm failure.	C. Corrosive attack. Consult factory.

7. Cannot reach upper or lower pressure levels of stated range.

Possible Cause	Remedy
A. Improper sensor sub-assembly setting.	A. Remove sensor sub-assembly. Check dimension to those indicated in Figure 10. If dimension is correct, and high setting cannot be reached, decrease dim. "X" by rotating sensor end plate 1/2 revolution CW; reverse for lower setting.

## SECTION VIII

### VIII. ORDERING INFORMATION: NEW REPLACEMENT UNIT vs PARTS "KIT" FOR FIELD REPAIR

To obtain a quotation or place an order, please retrieve the Serial Number and Product Code that was stamped on the metal name plate and attached to the unit. This information can also be found on the Bill of Material (parts list) that was provided when unit was originally shipped.) (Serial Number typically 6 digits). Product Code typical format as follows: (last digit is alpha character that reflects revision level for the product).

□□□□ - □□□□ 7 - □□□□□□□□□□

#### NEW REPLACEMENT UNIT:

Contact your local Cashco, Inc., Sales Representative with the Serial Number and Product code. With this information they can provide a quotation for a new unit including a complete description, price and availability.

#### PARTS "KIT" for FIELD REPAIR:

Contact your local Cashco, Inc., Sales Representative with the Serial Number and Product code. Identify the parts and the quantity required to repair the unit from the Bill of Materials sheet that was provided when unit was originally shipped.

**NOTE:** *Those part numbers that have a quantity indicated under "Spare Parts" in column "A" reflect minimum parts required for inspection and rebuild, - "Soft Goods Kit". Those in column "B" include minimum trim replacement parts needed plus those "Soft Goods" parts from column "A".*

If the "BOM" is not available, refer to the cross-sectional drawings included in this manual for part identification and selection.

Local Sales Representative will provide quotation for appropriate Kit Number, Price and Availability.



### CAUTION

**Do not attempt to alter the original construction of any unit without assistance and approval from the factory. All purposed changes will require a new name plate with appropriate ratings and new product code to accomodate the recommended part(s) changes.**

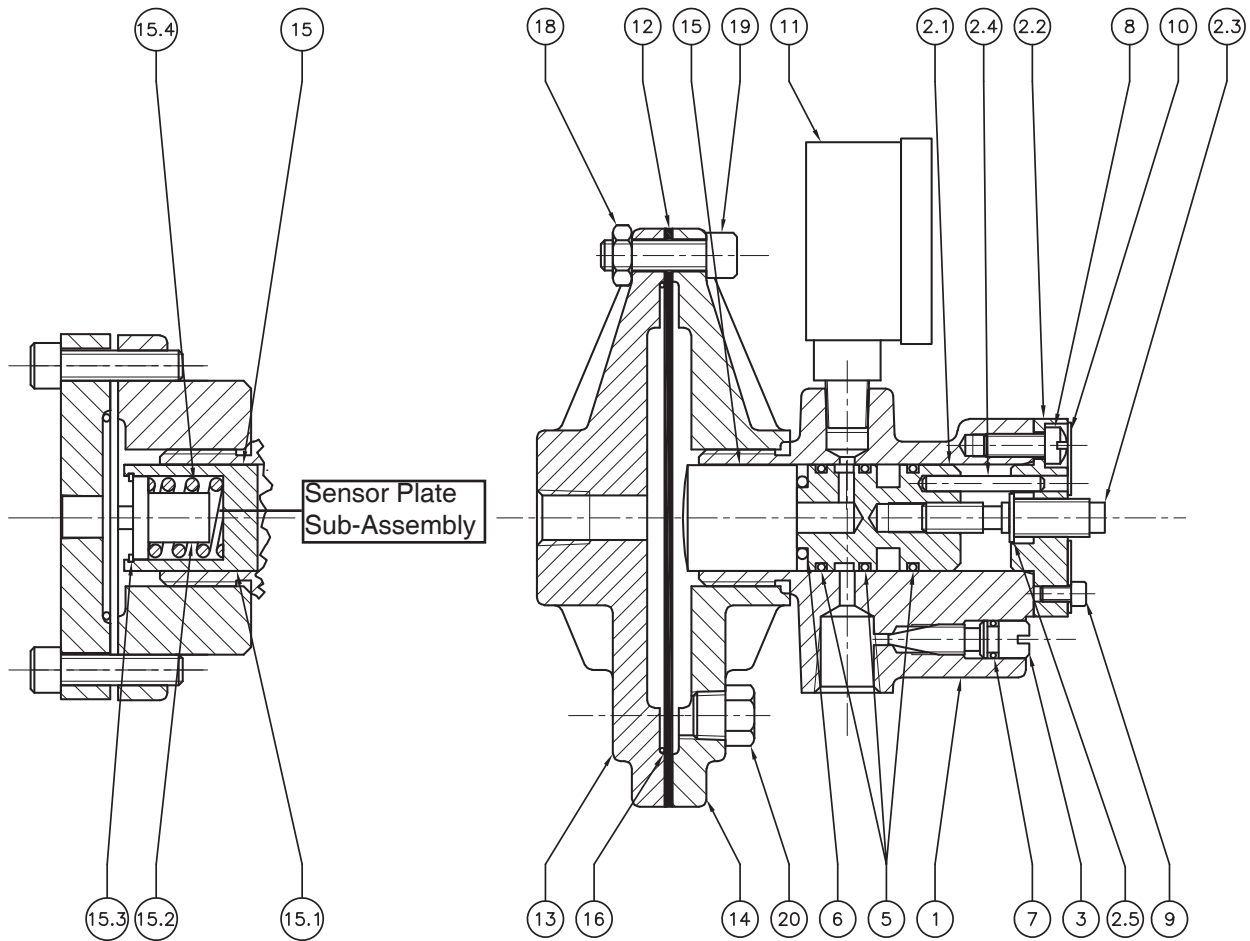

Sensor Plate Sub-Assembly  
450-2500 psig Range

Figure 12  
Model 764P

Available Ranges	
psig	(Barg)
1-30	(0.7-2.1)
20-100	(1.4-6.9)
50-150	(3.5-10.3)
90-500	(6.2-34.5)
450-2500	(31.0-172.4)
2"-30" Hg Vac.	(50-760 mm Hg Vac.)

ITEM NO.	DESCRIPTION	ITEM NO.	DESCRIPTION	
1	Housing	12	Diaphragm	
2	Sensor Sub-Assembly	13	Upper Case	
2.1	Sensor	*	14	Lower Case
2.2	End Plate	*	15	Sensor Plate Sub-Assembly
2.3	Adjusting Screw	*	15.1	Sensor Plate
2.4	Sensor Pin	*	15.2	Adaptor
2.5	Retainer Clip	*	15.3	Retaining Ring
3	Needle Valve	15.4	Spring	
5	O-Ring - Sensor	16	O-ring - Diaphragm	
6	O-Ring - Sensor Plate	17	Diaphragm Cover (if supplied)	
7	O-Ring - Needle Valve	18	Nut	
8	End Plate Screw	19	Screw	
9	Name Plate Screw	20	Vent Plug	
10	Name Plate			
11	Gauge			

\* Not Sold as individual parts.  
(Purchase Sensor Sub\_Assembly 2)

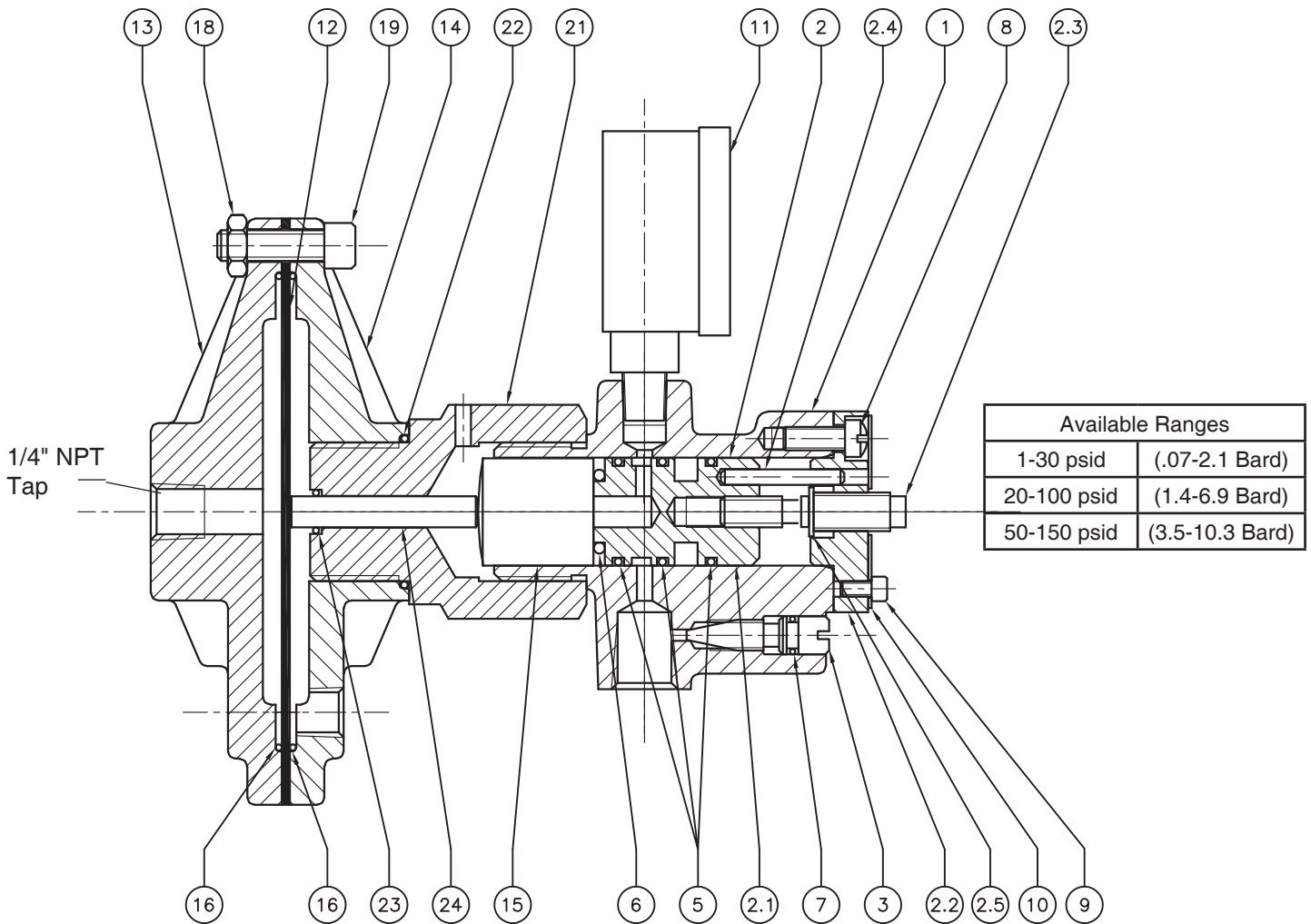

**Figure 13**  
**Model 764PD**

<u>ITEM NO.</u>	<u>DESCRIPTION</u>	<u>ITEM NO.</u>	<u>DESCRIPTION</u>
1	Housing	11	Gauge
2	Sensor Sub-Assembly	12	Diaphragm
2.1	Sensor *	13	Upper Case
2.2	End Plate *	14	Lower Case
2.3	Adjusting Screw *	15	Sensor Plate
2.4	Sensor Pin *	16	O-ring – Diaphragm
2.5	Retainer Clip *	17	Diaphragm Cover (if supplied)
3	Needle Valve	18	Nut
5	O-Ring - Sensor	19	Screw
6	O-Ring - Sensor Plate	21	Adaptor
7	O-Ring - Needle Valve	22	O-Ring – Adaptor
8	End Plate Screw	23	O-Ring – Pusher Post
9	Name Plate Screw	24	Pusher Post
10	Name Plate		

**\* Not Sold as individual parts.**  
**(Purchase Sensor Sub-Assembly 2)**