



# MODEL 1164

## BACK PRESSURE / RELIEF REGULATOR

### SECTION I

#### I. DESCRIPTION AND SCOPE

The Model 1164 is a modulating back pressure relief regulator used to control upstream (inlet) pressure. Sizes are 3/4", 1", 1-1/2" and 2" (DN 20, 25, 40 and 50) for side (inlet, flow-thru,) and bottom (discharge) connections. With proper trim utilization the unit is suitable for liquid, gaseous, or steam service. Refer to Technical Bulletin 1164-TB for design conditions and selection recommendations.



#### CAUTION

This is not a safety device and must not be substituted for a code approved pressure safety relief valve or a rupture disc.

### SECTION II

#### II. INSTALLATION

1. An inlet block valve should always be installed.
2. If service application is continuous such that shutdown is not readily accomplished, it is recommended that an inlet block valve, outlet block valve, and a manual bypass valve be installed.
3. Pipe unions should be installed to allow removal from piping.
4. An inlet pressure gauge should be located approximately ten pipe diameters upstream and within sight. An outlet pressure gauge is optional.
5. All installations should include an upstream relief device if the inlet pressure could exceed the pressure rating of any equipment or the maximum inlet pressure rating of the unit.

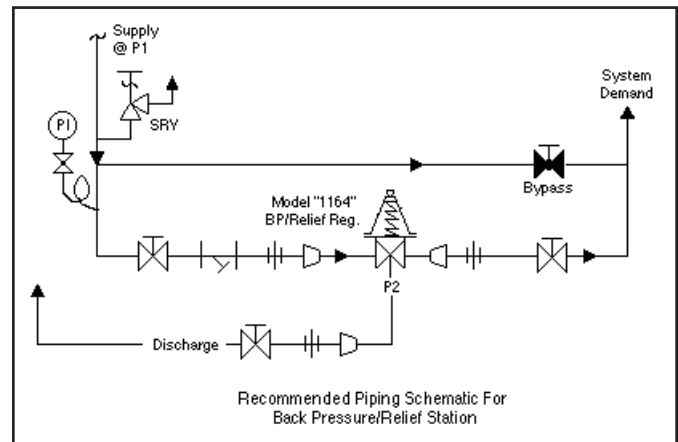

7. In placing thread sealant on pipe ends prior to engagement, ensure that excess material is removed and not allowed to enter the regulator upon startup.
8. Flow Direction: Install so the flow direction matches the arrow cast on the body. Connect the inlet pressure to the body side connection(s). Fluid will relieve out of the bottom connection. The double inlet connections are for in-line installation (plug one side connection if in-line installation is not required).



#### WARNING

The maximum inlet pressure is equal to 1.5 times the larger number of the stated range spring on the nameplate, and is the recommended "upper operative limit" for the sensing diaphragm. Higher pressures could damage the diaphragm. (Field hydrostatic tests frequently destroy diaphragms. DO NOT HYDROSTATIC TEST THRU AN INSTALLED UNIT; ISOLATE FROM TEST.)

6. Clean the piping of all foreign material including chips, welding scale, oil, grease and dirt before installing the regulator. Strainers are recommended.



#### CAUTION

Installation of adequate overpressure protection is recommended to protect the regulator from overpressure and all downstream equipment from damage in the event of regulator failure.



## CAUTION

**For welded installations, all internal trim parts, seals and diaphragm(s) must be removed from regulator body prior to welding into pipeline. The heat of fusion welding will damage non-metallic parts if not removed. NOTE: This does not apply to units equipped with extended pipe nipples.**

9. Regulator may be installed in a vertical or horizontal pipe. If it is a steam system, assure the piping is properly trapped and oriented.
10. Regulator may be rotated around the pipe axis 360°. Recommended positions are with spring

chamber vertical upwards, or horizontal. Orient such that the spring chamber vent hole does not collect rainwater or debris.

11. Regulators are not to be direct buried underground.
12. For insulated piping systems, recommendation is to not insulate regulator.
13. Spring Chamber Vent Tap - Option 1164-25: 1/4" NPT Vent. Leave connection vented to atmosphere or pipe to outside or sump (the later if fluid through valve is toxic or could present a hazard) depending on the application and the controlled fluid.

## SECTION III

### III. PRINCIPLE OF OPERATION

1. Movement occurs as pressure variations register on the diaphragm. The registering pressure is the inlet,  $P_1$  or upstream pressure. The range spring opposes diaphragm movement. As inlet pressure drops, the range spring pushes the diaphragm down, closing the port; as inlet pressure increases, the diaphragm pushes up and the port opens.
2. A complete diaphragm failure may cause the valve to fail closed. A cracked metal diaphragm will leak fluid thru the vent hole of the spring chamber, but will continue to operate.

## SECTION IV

### IV. STARTUP:

1. Start with the block valves closed. A bypass valve may be used to maintain system pressure without changing the following steps.
2. Relax the range spring by turning the adjusting screw counterclockwise (CCW) a minimum of three (3) full revolutions. This reduces the inlet (upstream) pressure set point.
3. If it is a "hot" piping system, and equipped with a bypass valve, slowly open the bypass valve to pre-heat the system piping and to allow slow expansion of the piping. Assure proper steam trap operation if installed. Closely monitor inlet (upstream) pressure, via gauge, to assure not over-pressurizing. NOTE: If no bypass valve is installed, extra caution should be used in starting up a cold system; i.e. do everything slowly.
4. Crack open the inlet (upstream) block valve.
5. Slowly open the outlet (downstream) block valve observing the inlet (upstream) pressure gauge. Determine if the regulator is flowing. If not, slowly rotate the regulator adjusting screw counterclockwise (CCW) until flow begins.
6. Continue to slowly open the outlet (downstream) block valve until fully open.
7. Observing the inlet (upstream) pressure gauge, rotate the adjusting screw clockwise (CW) slowly until the inlet pressure begins to rise. Rotate CW until the desired setpoint is reached.
8. Continue to slowly open the inlet (upstream) block valve. If the inlet (upstream) pressure exceeds the desired setpoint pressure, rotate the adjusting screw CCW until the pressure decreases.
9. When flow is established steady enough that both the outlet and inlet block valves are fully open, begin to slowly close the bypass valve if installed.
10. Develop system flow to a level near its expected normal rate, and reset the regulator setpoint by turning the adjusting screw CW to increase inlet pressure, or CCW to reduce inlet pressure.
11. Reduce system flow to a minimum level and observe setpoint. Inlet pressure will rise from the setpoint of Step 9. (Ensure that this rise does not exceed the stated upper limit of the range spring by greater than 50%; i.e. 30-80 psig (2.07-5.52 Barg) range spring, at maximum flow the inlet pressure should not exceed 1.5 x 80 psig (5.6 Barg), or 120 psig (8.3 Barg). If it does, consult factory.)
12. Increase flow to maximum level if possible. Inlet (upstream or  $P_1$ ) pressure should fall off. Readjust setpoint as necessary at the normal flow rate.

## SECTION V

### V. SHUTDOWN

1. On systems with a bypass valve, and where system pressure is to be maintained as the regulator is shut down, slowly open the bypass valve while closing the inlet (upstream) block valve. Fully close the inlet (upstream) block valve. (When on bypass, the system pressure must be constantly observed and manually regulated.) Close the outlet (downstream) block valve.



#### CAUTION

**Do not walk away and leave a bypassed regulator unattended.**

2. If the regulator and system are both to be shutdown, slowly close the inlet (upstream) block valve. Close the outlet (downstream) valve only if regulator removal is required.

## SECTION VI

### VI. MAINTENANCE



#### WARNING

**SYSTEM UNDER PRESSURE.** Prior to performing any maintenance, isolate the regulator from the system and relieve all pressure. Failure to do so could result in personal injury.

#### A. General:

1. Maintenance procedures hereinafter are based upon removal of the regulator from the pipeline where installed.
2. Owner should refer to owner's procedures for removal, handling, cleaning and disposal of non-reusable parts, i.e. asbestos gaskets, etc.
3. Refer to Figure 1 for basic regulator construction. For a blow-up of the TFE seat trim, see Figure 2.



#### WARNING

**SPRING UNDER COMPRESSION.** Prior to removing spring chamber, relieve spring compression by backing out the adjusting screw. Failure to do so may result in flying parts that could cause personal injury.

#### B. Diaphragm Replacement:

1. Securely install the body (1) in a vise with the spring chamber (2) directed upwards.
2. Relax range spring (3) by turning adjusting screw (17) CCW until removed from spring chamber (2).
3. Draw or embed a match mark between body casting (1) and spring chamber casting (2) along flanged area.
4. Remove all diaphragm flange nuts (14) and bolts (13).

5. Remove spring chamber (2), range spring (3) and spring button (4).
6. Remove pressure plate (5) and inspect to ensure no deformation due to over-pressurization. If deformed, replace.
7. Remove diaphragm (9), diaphragm gasket (10), and O-ring (11).
8. Clean body (1) and diaphragm flange. **NOTE:** *On valves originally supplied as "special cleaned", option 1164-55, maintenance must include a level of cleanliness equal to Cashco's cleaning standard #S-1134. Contact factory for details.*
9. Install new O-ring (11), diaphragm gasket (10), and diaphragm. Apply a light coat of gasket sealant.



#### CAUTION

**When reassembling, the spring (7) will be under compression. Center all internal parts before placing the spring chamber.**

10. Center pressure plate (5) on diaphragm (9). Place the range spring (3) on to the retainer hub of the pressure plate (5).
11. Place multi-purpose, high temperature grease into depression of spring button (4) where adjusting screw bears. Set spring button (4) onto range spring (3); ensure spring button (4) is laying flat.
12. Aligning the match marks, place spring chamber (2) over the above stacked parts. Apply pressure (manually) to the spring chamber (2) from opposite sides to compress the spring (7), so bolting can be started from opposite sides. Install all bolts (13) and nuts (14) by

hand tightening. Mechanically tighten bolting (13 & 14) in a cross pattern that allows spring chamber (2) to be pulled down evenly. Recommended torques are as follows:

Regulator Size	Bolt Size	Metal Diaphragm
3/4" - 1" (DN20,25)	3/8" - 24	30 ft/lbs.
1-1/2" (DN40)	7/16" - 20	45 ft/lbs.
2" (DN50)	1/2" - 20	70 ft/lbs.

**NOTE:** Never replace bolting (13 & 14) with just any bolting if lost. Bolt heads and nuts are marked with specification identification numbers. Use only proper grades as replacements.

13. Reinstall adjusting screw (17) with locknut (8).
14. Soap solution test around bolting (13 & 14) and body (1) and spring chamber (2) flanges for leakage. Ensure that an inlet pressure is maintained during this leak test of at least mid-range level; i.e. 30-80 psig (2.07-5.52 Barg) range spring, 60 psig (4.14 Barg) test pressure minimum.

#### C. Trim Replacement (For Metal Seated Units):

1. Trim removal requires that the diaphragm be removed. Refer to previous procedure Section VI., Sub-section B, Steps 1 through 8.
2. Remove valve guide (12), valve plug (16) and spring (7).
3. Inspect seating surface of integral seat ring (15). If seat ring shows erosion or wear, the regulator should be replaced.

4. Inspect guide (12), plug (16), O-ring (11) and spring (7). Inspect parts for excessive wear. Replace if worn, nicked or depressed.
5. Clean the body (1) cavity. Clean all parts to be reused. **NOTE:** On regulators originally supplied with Option 1164-55, "special cleaned", maintenance must include a level of cleanliness equal to Cashco's cleaning standard #S-1134. Contact factory for details.
6. Reinstall the spring (7). Then place the O-ring (11) on the plug (16) and the plug (16) into the valve guide (12).
7. Now place the valve guide (12) (along with the O-ring (11) and plug (16)) on to the spring (7).
8. Reinstall diaphragm (9) per Section VI., Sub-section B., Steps 9 through 14.
9. Bench test unit for suitable operation. **NOTE:** Regulators are not tight shutoff devices. Even if pressure falls below setpoint, a regulator may or may not develop bubble tight shutoff. In general, tighter shutoff can be expected with composition seat.
10. Soap solution test around body (1) flange for leakage. Test pressure should be the maximum allowed.

#### D. Trim Replacement (For TFE Seated Units):

1. Follow same steps as listed under "Trim Replacement - Metal Seated Units" except for the following guidelines:
2. When inspecting parts for excessive wear (VI.C.4), ensure there are no foreign particles embedded or nicks in the TFE seat which is an integral part of the plug assembly. Replace plug assembly (16) if any of these conditions are noted.

## SECTION VII

### VII. TROUBLE SHOOTING GUIDE

1. Erratic Operation; chattering.

Possible Causes	Remedies
A. Oversized regulator.	A1. Check actual flow conditions, resize regulator for minimum and maximum flow. Tighten flange bolting. A2. Increase flow rate. A3. Decrease regulator pressure drop; decrease inlet pressure by placing a throttling orifice in inlet piping union. A4. Install next step higher range spring. A5. Before replacing regulator, contact factory.
B. Inadequate Rangeability.	B1. Increase flow rate. B2. Decrease regulator pressure drop. B3. Install next step higher range spring. Contact factory.

2. Regulator inlet (upstream) pressure too high.

Possible Causes	Remedies
A. Regulator undersized.	A1. Confirm by opening bypass valve together with regulator. A2. Check actual flow conditions, resize regulator; if regulator has inadequate capacity, replace with larger unit.
B. Incorrect range spring (screwing out CCW of adjusting screw does not allow bringing pressure level to a stable and proper level).	B.1 Replace range spring with proper lower range. B.2 Contact factory.
C. Too much build.	C1. Review build expected. C2. Contact factory.
D. Restricted diaphragm movement.	D. Ensure no moisture in spring chamber at temperatures below freeze point. Ensure no dust or debris entering vent opening. If rainwater or debris can enter, reorient spring chamber.

3. Excessive seat leakage.

Possible Causes	Remedies
A. Foreign matter on the seating surface, erosion of the seating surface or foreign matter on plug balancing O-ring.	A. Clean or replace plug assembly (TFE seat). For metal replace regulator if integral seat is damaged. Replace plug and O-ring.

4. Leakage through the spring chamber vent hole.

Possible Causes	Remedies
A. Normal-life diaphragm failure.	A. Replace diaphragm.
B. Abnormal short-life diaphragm failure.	B1. Can be caused by excessive chattering. See No. 1. to remedy chatter. B2. Can be caused by corrosive action. Consider alternate diaphragm material. B3. Upstream (inlet) pressure build-up occurring that over-stresses diaphragms. Relocate regulator or protect with safety relief valve.

5. Sluggish operation.

Possible Causes	Remedies
A. Plugged spring chamber vent.	A. Clean vent opening.
B. Fluid too viscous.	B. Heat fluid. Contact factory.
C. Broken spring.	C. Replace spring.

## SECTION VIII

### VIII. ORDERING INFORMATION: NEW REPLACEMENT UNIT vs PARTS "KIT" FOR FIELD REPAIR

To obtain a quotation or place an order, please retrieve the Serial Number and Product Code that was stamped on the metal name plate and attached to the unit. This information can also be found on the Bill of Material (parts list) that was provided when unit was originally shipped.) (Serial Number typically 6 digits). Product Code typical format as follows: (last digit is alpha character that reflects revision level for the product).

□□□□ - □□□□ 7 - □□□□□□□□□□

#### **NEW REPLACEMENT UNIT:**

Contact your local Cashco, Inc., Sales Representative with the Serial Number and Product code. With this information they can provide a quotation for a new unit including a complete description, price and availability.



#### **CAUTION**

**Do not attempt to alter the original construction of any unit without assistance and approval from the factory. All purposed changes will require a new name plate with appropriate ratings and new product code to accommodate the recommended part(s) changes.**

#### **PARTS "KIT" for FIELD REPAIR:**

Contact your local Cashco, Inc., Sales Representative with the Serial Number and Product code. Identify the parts and the quantity required to repair the unit from the Bill of Materials sheet that was provided when unit was originally shipped.

**NOTE:** *Those part numbers that have a quantity indicated under "Spare Parts" in column "A" reflect minimum parts required for inspection and rebuild, - "Soft Goods Kit". Those in column "B" include minimum trim replacement parts needed plus those "Soft Goods" parts from column "A".*

If the "BOM" is not available, refer to the cross-sectional drawings included in this manual for part identification and selection.

Local Sales Representative will provide quotation for appropriate Kit Number, Price and Availability.

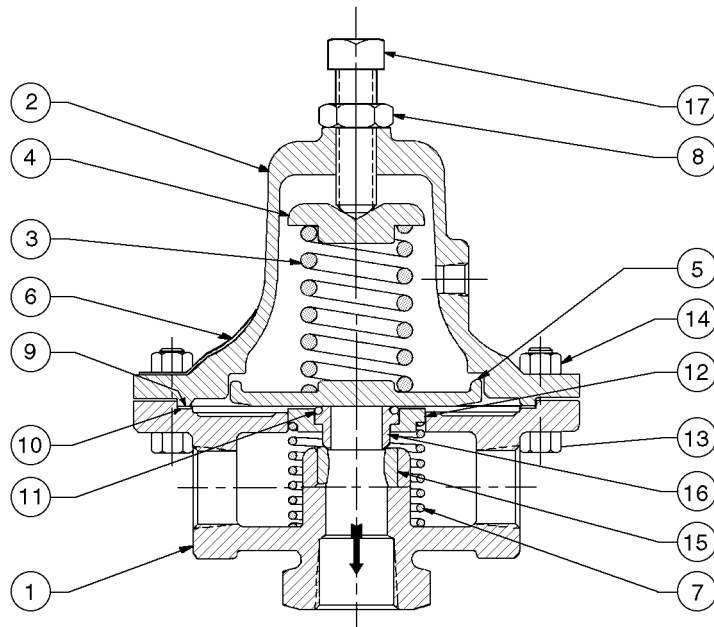

**Figure 1**  
Basic Model 1164  
Metal Seat Construction

<u>Item No.</u>	<u>Description</u>
1	Body
2	Spring Chamber
3	Range Spring
4	Spring Button
5	Pressure Plate
6	Name Plate
7	Spring
8	Adjusting Screw Lock Nut
9	Diaphragm
10	Diaphragm Gasket
11	O-Ring
12	Valve Guide
13	Cap Screw (Flange Bolting)
14	Nut (Flange Bolting)
15	Valve Seat
16	Valve Plug or Valve Plug Subassembly
17	Adjusting Screw

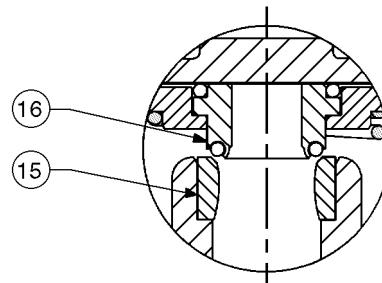

**Figure 2**  
Composition Seat

Cashco, Inc.  
P.O. Box 6  
Ellsworth, KS 67439-0006  
PH (785) 472-4461  
FAX (785) 472-3539  
[www.cashco.com](http://www.cashco.com)  
E-mail: [sales@cashco.com](mailto:sales@cashco.com)  
[exportsales@cashco.com](mailto:exportsales@cashco.com)  
Printed in U.S.A. IOM-1164