



Model E

Thermostatic Valve



Model EF

FEATURES

- FLOW RATES OF 40 - 75 USGPM
- TAMPER-PROOF TEMPERATURE SETTINGS OF 85°F TO 235°F
- COMPLETELY SELF-CONTAINED
- COMBINATIONS AVAILABLE:
CAST IRON, STEEL, & STAINLESS STEEL
1-1/4" & 1-1/2" PIPE SIZES
THREADED & FLANGED CONNECTIONS
- HIGH PRESSURE VERSIONS UP TO
CLASS 600# FLANGES

APPLICATIONS

- ENGINE & COMPRESSOR COOLING SYSTEMS
- LUBE OIL SYSTEMS
- COGENERATION HEAT RECOVERY LOOPS
- PROCESS CONTROL
- TEMPERATURE MIXING OR DIVERTING

AMOT Model E Thermostatic Valves are fully automatic, 3-way fluid temperature controllers for diverting or mixing applications. They are used to provide reliable control of fluid temperatures in engine jacket water and lubricating oil cooling systems. These valves are suitable for process control and industrial applications where fluids must be mixed or diverted depending on their temperatures. They may also be applied to cogeneration systems to control temperatures in the heat recovery loop assuring proper engine cooling and maximizing heat recovery.

Tamper-Proof

As with other AMOT thermostatic valves, they utilize fully enclosed, factory-set temperature element assemblies which provide tamper-proof operation. To change a valve setting, it is necessary to exchange the temperature element assembly.

Versatile

Model E Valves can also be supplied with special Nickel plated element assemblies and Neoprene seals to resist the corrosive effects of ammonia-contaminated oil in refrigeration compressor service.

Viton seals can be supplied for use in fluids which attack Buna N such as phosphate ester and diester oils. With such oils, nickel plated element assemblies should be requested for protection of the bronze parts.

High Resistance to Shock

AMOT thermostatic valves display excellent reliability even under extreme shocks or vibration and can be qualified to MIL-S-901 and MIL-V-19772.

Other AMOT Thermostatic Valves are available for water flow rates of 9-2800 USGPM, see Form No. 913.

Operation

The valve is supplied with the temperature element assembly factory-set to the nominal temperature setting. Temperature is sensed at Port A which remains open to Port B (bypass) until the fluid temperature reaches a point 8-10°F below the nominal setting. As the temperature continues to rise, the sliding valve moves to close off Port B and open Port C (connected to the cooler or heat exchanger.) Port B is fully closed 8-10°F above the nominal setting. The valve continually modulates the fluid flow to maintain the nominal temperature. For optimum control, the system should be sized so about 1/2 the total fluid flow is passing through the cooler at full load.

For long life, AMOT Model E valves should not be exposed to continuous temperatures exceeding 65°F above their nominal temperature setting. For occasional short periods such as 1/2 hour, they can be exposed to temperatures of 90°F above their nominal temperature setting, but 250°F maximum.

Piping Diagrams

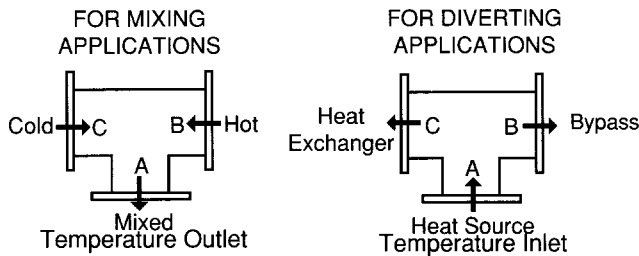

Specifications

Internal Trim Materials	Bronze
Standard Seal Material	Buna N
Max. Allowable Pressure Across Valve..	20 psi (138 kPa)
Valve Pressure Rating - ELC	355 psi (2448 kPa)
EFCF	155 psi (1069 kPa)
EFSJ, EMSJ	230 psi (1586 kPa)
EFSH, EMSH	655 psi (4516 kPa)
EFSK, EMSK	1,000 psi (6895 kPa)
Net Weight	
1-1/2ELC	8 lbs (4 kg)
1-1/4EF	20 lbs (9 kg)
1-1/2EF	20 lbs (9 kg)
1-1/2EFSH	30 lbs (14 kg)
1-1/2EFSK	36 lbs (16 kg)

Selection

AMOT thermostatic valves are selected by the anticipated flow rate through the valve. Refer to Fig. 1. Pressure drop across the valve is usually limited to approximately 2 to 7 psi to maintain good temperature regulation.

Versions available from USA factory. Contact factory for Stainless Steel Versions.

Cast Iron	Steel
1-1/4 EFCF	1-1/2 EFSJ
1-1/2 EFCF	1-1/2 EFSH
1-1/2 ELCT	1-1/2 EMSJ
	1-1/2 EMSH
	1-1/2 EFSK
	1-1/2 EMSK

MODEL 1-1/2 EL

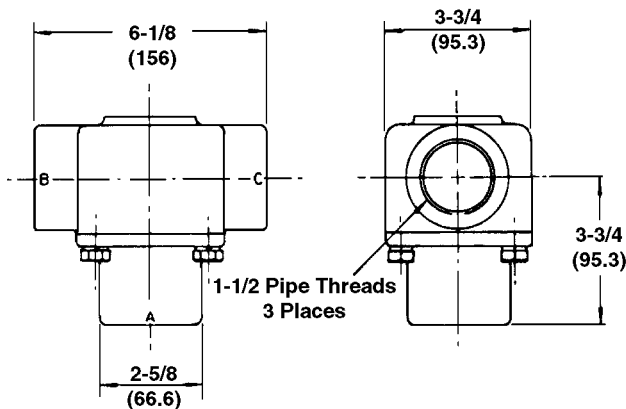

MODEL 1-1/4 EF, 1-1/2 EF, 1-1/2 EM

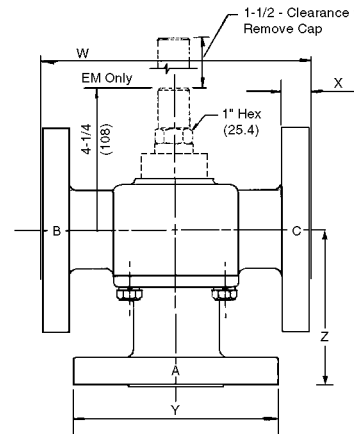

Selection / Dimensions

Model No.	Nominal Size	"W"	"X"	"Y"	"Z"	No. of Holes	Dia. of Holes "D"	Bolt Circle
1-1/4EFCF	1-1/4 (32)	6-7/8 (175)	5/8 (16)	4-5/8 (117)	3-29/32 (99)	4	5/8 (16)	3-1/2 (89)
1-1/2EFCF	1-1/2 (40)	6-7/8 (175)	5/8 (16)	5 (127)	3-29/32 (99)	4	5/8 (16)	3-7/8 (98)
1-1/2EFSJ	1-1/2 (40)	7 (178)	9/16 (14)	5 (127)	3-31/32 (101)	4	5/8 (16)	3-7/8 (98)
1-1/2EMSJ	1-1/2 (40)	7 (178)	9/16 (14)	5 (127)	3-31/32 (101)	4	5/8 (16)	3-7/8 (98)
1-1/2EFSH	1-1/2 (40)	8 (203)	13/16 (21)	6-1/8 (156)	4-3/4 (121)	4	7/8 (22)	4-1/2 (114)
1-1/2EMSH	1-1/2 (40)	8 (203)	13/16 (21)	6-1/8 (156)	4-3/4 (121)	4	7/8 (22)	4-1/2 (114)
1-1/2EFSK	1-1/2 (40)	8-3/4 (222)	1-1/8 (29)	6-1/8 (156)	5-1/8 (130)	4	7/8 (22)	4-1/2 (114)
1-1/2EMSK	1-1/2 (40)	8-3/4 (222)	1-1/8 (29)	6-1/8 (156)	5-1/8 (130)	4	7/8 (22)	4-1/2 (114)

Dimensions in inches, Millimeters in ().

How to Order

When ordering please specify the following:

- Pipe size connection: 1-1/4" Flanged
1-1/2" Flanged
1-1/2" Threaded
See Table D & "Selection" section.
- Indicate Model E.
- Housing material: cast iron, steel, or stainless steel (See "Selection" section).
- Nominal temperature setting, see Table E.
- Any of the following special features if required:
 - Nickel plated temperature element assembly.
 - Viton seals, Neoprene seals.
 - Electroless Nickel Plated Temperature Element Assembly
 - Temperature Element Assembly Leak Hole, see Table G.

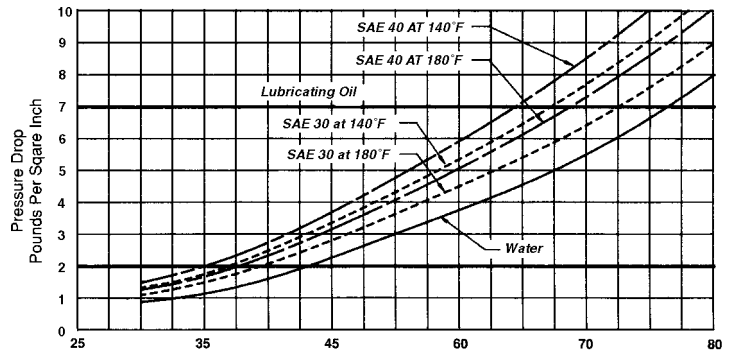

Fig. 1

Flow in U.S. Gallons Per Minute
Recommended Pressure Drop is 2 to 7 psi

Model Code Table

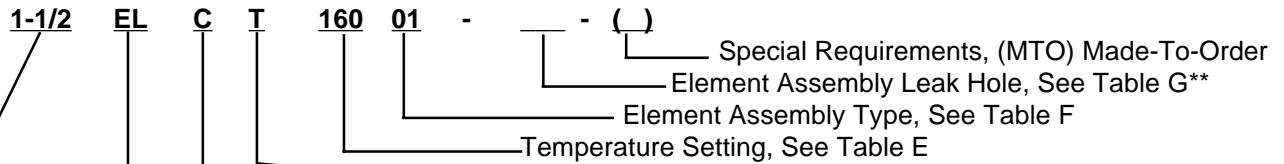

TABLE A Valve Size Inches (mm)	TABLE B Valve Type Code No. Material	TABLE C Body Material Code No. Material	TABLE D* Connections Code No. Type
1-1/4 (32)	EL Threaded Connections	C Cast Iron	FLANGED CONNECTIONS F ANSI B16.1 (125 lb Class) Flat Face Flange J ANSI B16.5 (150 lb Class) Raised Face Flange H ANSI B16.34 (300 lb Class) Raised Face Flange K ANSI B16.37 (600 lb Class) Raised Face Flange
1-1/2 (40)	EF Flanged Connections EM Manual Override	S Steel R Stainless Steel	THREADED CONNECTIONS T Threaded NPT to USAS B2.1 V Threaded BSP (Tr) and Japanese JIS W Threaded to SAE J514h straight thrd O-ring seal

TABLE E Temperature Setting Code Nominal Temp			TABLE E (Continued) Temperature Setting Code Nominal Temp			TABLE F Element Assembly Type Code No. Type		TABLE G** Element Assembly Leak Hole Code Size		
No.	°F	(°C)	No.	°F	(°C)	No.	Type	No.	Inches	(mm)
085	085	(29)	170	170	(77)	01	5435X Standard	none	(standard)	
095	095	(35)	175	175	(79)	02	5435P Plated w/Viton Seals	A	1/8"	(3.2)
100	100	(38)	180	180	(82)	03	5435X w/Viton Seals	B	1/4"	(6.4)
110	110	(43)	190	190	(88)	04	5435P Plated w/Buna N Seals	C	3/16"	(4.8)
120	120	(49)	205	205	(96)	05	5435X w/Neoprene Seals	D	1/16"	(1.6)
130	130	(54)	237	237	(114)	06	5435K Electroless Nickel plated w/ Neoprene Seals			
140	140	(60)				07	9831X Manual Override 10912X Manual Override, EMSK			
150	150	(66)				08	9831P Plated Manual, Viton 10912P Plated Manual, EMSK, Viton Seals			
160	160	(71)								

NOTE: Letters or numbers in the MTO space, other than nothing, AI or AA, indicate the unit is built to special requirements and some of the other code numbers may not be valid. Check with the factory for full specification of such models.

* Former model coding generally omitted Table D.

** Table G is to be omitted on any valve made in the USA not requiring a leak hole.

Indicates Non-Standard, Special Charges May Apply

Service Parts

Ref No.	Part No.	Qty.	Description
For Model EL, EF (except EFSK, EMSK)			
4	1919	1	O-ring, Buna N
5	5435X-(temp)	1	Element Assembly, specify temperature in °F
6	5695	1	Gasket (prior to Serial No. A801)
6	11090L001	1	O-ring (after Serial No. A801)
For Model EL, EF (except EFSK, EMSK)			
4	1919L001	1	O-ring, Viton
5	5435X-(temp)	1	Element Assembly, specify temperature in °F
6	5695	1	Gasket (prior to Serial No. A801)
6	11090L002	1	O-ring (after Serial No. A801)
For Model EFSK			
4	1919	1	O-ring, Buna N
4	1919L001	1	O-ring, Viton (brown)
5	5435X-(temp)	1	Element Assembly, specify temperature in °F
6	10899	1	Housing Seal
For Model EM and EMSK			
4	1919	1	O-ring, Buna N
4	1919L001	1	O-ring, Viton (brown)
5	10912X-(temp)	1	Element Assembly for EMSK, specify temperature in °F
5	9831X-(temp)	1	Element Assembly for EM, specify temperature in °F
6	10899	1	Housing Seal
21	11152L001	1	Stem Seal, Buna N
21	1152L002	1	Stem Seal, Viton (brown)

Maintenance

Properly applied and installed, AMOT Thermostatic Valves require minimal maintenance.

If necessary, temperature element assemblies may be easily replaced. Remove Bolts (7) and separate the upper and lower housings. Remove Element Assembly (5) and Element O-ring Seal (4). Remove Housing Gasket (or O-ring in later versions) and clean any foreign material from sealing surfaces. Lubricate new Element O-ring Seal (4) with a good grade of petroleum grease and insert in the grooved sleeve in the Upper Housing (1). Insert Element Assembly (5) through Element Seal (4) with a twisting motion. Install housing seal O-ring (6), or Housing Gasket, around the Element Assembly Flange and bolt on Lower Housing (2).

Installation

AMOT Thermostatic Valves operate in any position and may be located at the convenience of the system designer. The valve can be supported by the connecting pipe but should not be subjected to excessive bending. Line up the piping before tightening the connecting bolts or the pipe threads.

If the valve is mounted at the high point of the system, the system should be properly vented to prevent trapping air at the temperature element assemblies.

For piping diagrams regarding specific applications, refer to Form 913, AMOT Thermostatic Valves General Information.

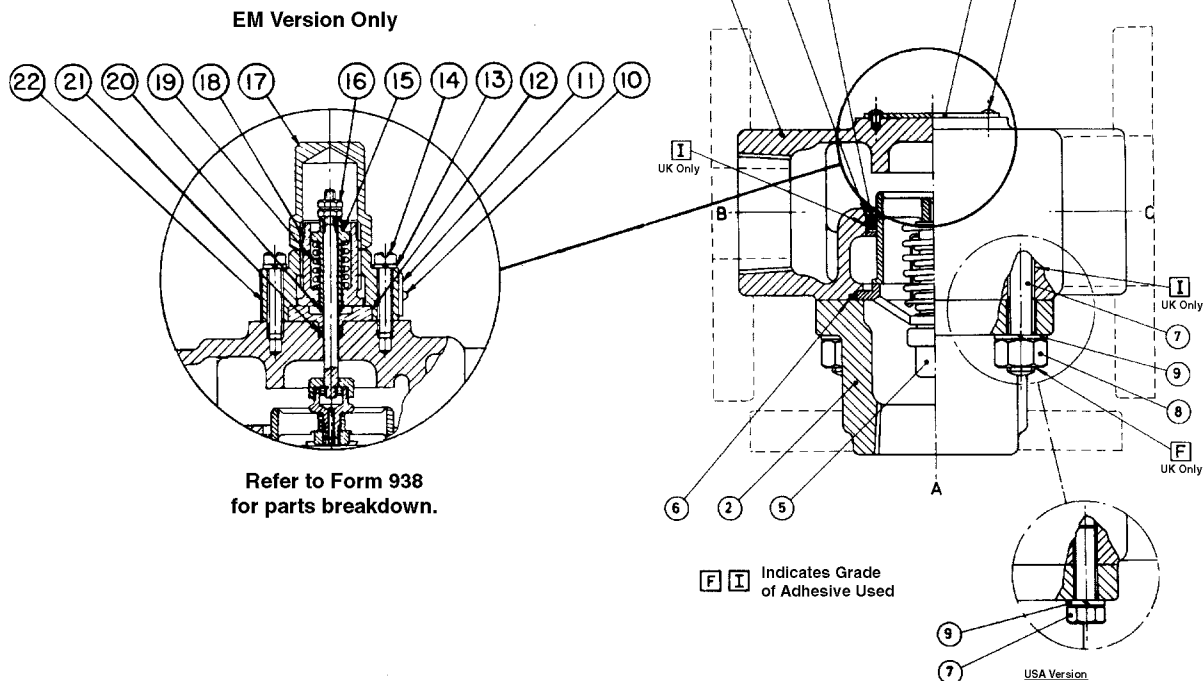

AMOT USA
401 First Street
Richmond, CA 94801
Tel: +1 510 236-8300
Fax: +1 510 234-9950

AMOT
Western Way
Bury St. Edmunds IP33 3SZ
Suffolk England
Tel: +44 1284 762222
Fax: +44 1284 760256

AMOT SINGAPORE
10 Eunos Road 8 # 12-06
Singapore Post Centre
Singapore 408600
Tel: +65 6293 4320
Fax: +65 6293 3307