



Model B

Thermostatic Valves



FEATURES

- FLOW RATES OF 68 - 1200 USGPM
- TAMPER-PROOF TEMPERATURE SETTINGS OF 55°F - 240°F
- COMPLETELY SELF-CONTAINED
- POSITIVE 3-WAY VALVE ACTION
- AVAILABLE IN CAST IRON, DUCTILE IRON, BRONZE, STEEL, AND STAINLESS STEEL
- 1-1/2" - 6" PIPE SIZES: FLANGED, AND THREADED CONNECTION

APPLICATIONS

- ENGINE & COMPRESSOR COOLING SYSTEM
- LUBE OIL SYSTEMS
- COGENERATION HEAT RECOVERY LOOPS
- PROCESS CONTROL
- TEMPERATURE MIXING OR DIVERTING

AMOT Model B Thermostatic Valves are fully automatic, 3-way fluid temperature control valves for diverting or mixing applications. They provide reliable control of fluid temperatures in engine jacket water and lubrication oil cooling systems. These valves are suitable for process control and industrial applications where fluids must be mixed or diverted depending on their temperatures. They may also be applied to cogeneration systems to control temperatures in the heat recovery loop assuring proper engine cooling and maximizing heat recovery.

TAMPER-PROOF

As with other AMOT thermostatic valve the Model B utilizes fully enclosed, factory-set temperature element assemblies which provide tamper-proof operation. To change a valve setting it is necessary to exchange the temperature element assemblies inside the valve.

HIGH RESISTANCE TO SHOCK

Model B thermostatic valves display excellent reliability even under extreme shocks or vibration and many models have been qualified to MIL-S-901 and MIL-V-19772.

MANUAL OVERRIDE

If desired, AMOT Model B thermostatic valves can be supplied with a manual override which allows the user to direct flows through Ports A and C. On valves equipped with the manual override option, there is one manual override device for each of the temperature element assemblies. To engage the manual override function, flip the lever(s) 180° from "Auto" to "Manual" position.

OPERATION

The valve is supplied with the temperature element assemblies factory-set to the nominal temperature setting. Temperature is sensed at Port A which remains open to Port B (bypass) until the fluid temperature reaches a point 5 - 10°F below the nominal setting. As the temperature continues to rise, the sliding valve moves to close off Port B and open Port C (connected to the cooler or heat exchanger) Port B is fully closed 8 - 10°F above the nominal setting. The valve continually modulates the fluid flow to maintain the nominal temperature. For optimum control, the system should be sized so about 1/2 the total fluid flow is passing through the cooler at full load.

For long life, AMOT Model B valves should not be exposed to continuous temperatures exceeding 25°F above their nominal temperature setting. For occasional short periods (1/2 hour or less), they can be exposed to temperatures of 50°F above their nominal temperature setting, but not to exceed 250°F maximum.

For higher over-temperatures, reduced stroke element assemblies (5566X) are available. They will withstand continuous temperatures of 60°F above their nominal temperature setting but add 30% to the valve pressure drop. Reduced stroke elements are not available in all temperatures.

INSTALLATION

AMOT thermostatic valves operate in any position and may be oriented at the convenience of the system designer. In the smaller sizes, the valve may be supported by the connecting pipe but should not be subjected to excessive bending. Line up the piping before tightening the connecting bolts. Larger sizes should not be used to support long and heavy lengths of pipe nor used to draw up lengths of pipe which have been fabricated too short.

If the valve is mounted at the high point of the system, the system should be properly vented to prevent trapping air at the temperature element assemblies.

For piping diagrams regarding specific applications, refer to Form 913, AMOT Thermostatic Valves General Information.

Figure 1

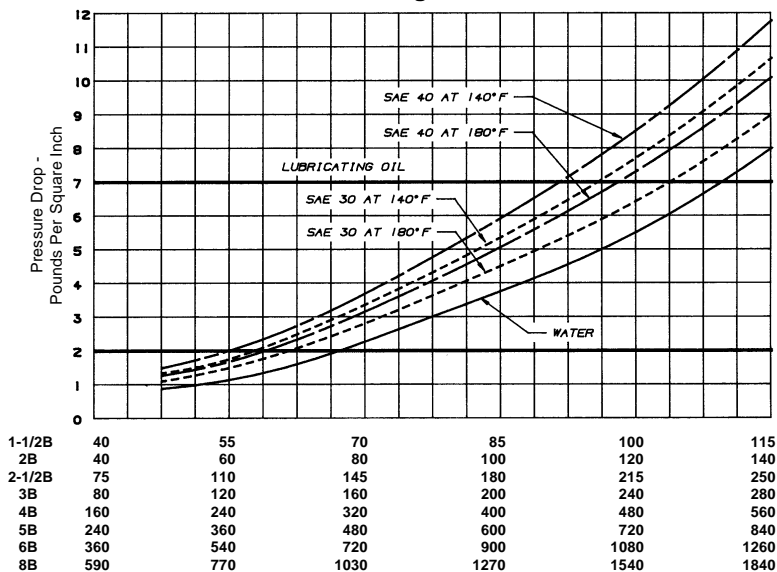

Flow in U.S. Gallons Per Minute
Recommended pressure drop is 2 to 7 psi.

SELECTION

AMOT thermostatic valves are selected by the anticipated flow rate through the valve. Refer to Fig. 1. Pressure drop across the valve is usually limited to approximately 2 psi to 7 psi to maintain good temperature regulation.

Threaded end connections are available on 1 1/2 and 2 inch sizes. Models with cast iron, ductile iron, or bronze housings have ANSI 125 lb flat face flanges. Steel or Stainless Steel housings feature ANSI Class 150 or 300 raised face flanges. Metric connections also available.

Models with steel housings have ANSI 150 lb/300 lb Class compatible raised face flanges.

Versions available from USA factory.

Cast Iron	Ductile Iron	Bronze	Steel
1-1/2BOCT	2BMDF	1-1/2BOBT	2BCSJ
1-1/2BHCT	2BFDF	2BOBT	2BCSH
2BOCT	2-1/2BMDF	2BCBF	2BMSJ
2BHCT	3BODF	2BFBF	2BMSH
2BMcF	4BEDF	2-1/2BMBF	2-1/2BOSJ
2BCCF	4BODF	3BOBF	2-1/2BMSJ
2BFCF	4BMDf	3BMBF	3BOSJ
2-1/2BOCF	5BODF	4BEBF	3BMSJ
2-1/2BMcF	5BMDf	4BOBF	3BOSH
3BOCF	6BODF	4BMBF	
3BMcF	6BMDf	5BOBF	
4BECF		5BMBF	
4BOCF		6BOBF	
4BMcF		6BMBF	
5BOCF			
5BMcF			
6BOCF			
6BMcF			

Indicates Non-Standard

PIPING DIAGRAMS

MODELS BO, BC, BM

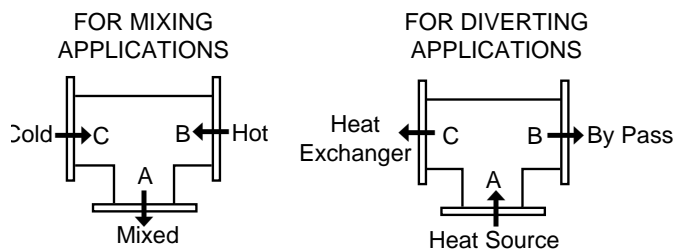

MODEL 1-1/2, 2, BO, BH, BF

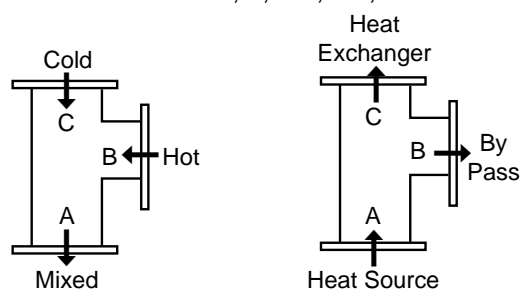

SPECIFICATIONS

Internal Trim Materials Bronze and Stainless Steel
 Standard Seal Material Buna N
 Max. Pressure Drop Across Valve 20 psi (1.4 Bar)
 Valve Pressure Ratings at 250°F
 Cast Iron, Ductile Iron, Bronze 150 psi (10 Bar)
 Cast Iron, Model BH 340 psi (23 Bar)
 Steel, Class 150, 245 psi (17 Bar)
 Steel, Class 300, 665 psi (46 Bar)
 Stainless Steel Class 150, 228 psi (15 Bar)
 Stainless Steel Class 300, 590 psi (41 Bar)

Shipping Weights:	Cast Iron	Ductile Iron	Bronze	Steel
1-1/2BO/2BO	25	--	--	--
1-1/2BH/2BH	32	--	--	--
1-1/2BM	--	--	25	--
2BC, BM	30	30	35	45
2BF	35	35	40	--
2-1/2B	55	55	75	75
3B	60	60	80	80
4B	135	135	150	--
5B	200	200	240	--
6B	270	270	300	--

HOW TO ORDER

(Refer to Model Code System Below.)

When ordering please specify the following:

1. Valve size connection (see Table A).
2. Valve Type (see Table B).
3. Housing material (see Table C).
4. Type of End Connection (see Table D).
5. Nominal temperature setting (see Table E).
6. Any of the following special features if required:
 - a) Viton or neoprene seals (instead of Buna N).
 - b) Electroless Nickel plated temperature element assembly.
 - c) Element leak hole (see Table G).
 - d) Reduced stroke element assembly for high over-temperature.

This product may be ordered using the full description as shown above or by constructing a Model No. using the Model Code System below. For special requirements, contact the AMOT factory or your local representative.

MODEL CODE SYSTEM

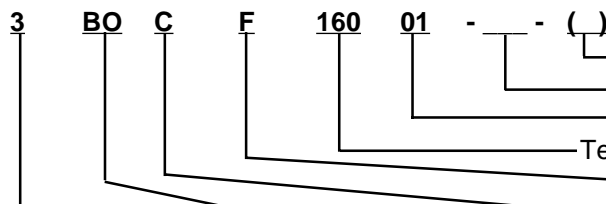

Special Requirements, (MTO) Made-To-Order
 Element Assembly Leak Hole, See Table G
 Element Assembly Type, See Table F
 Temperature Setting, See Table E

TABLE A Valve Size Inches (mm)		TABLE B Valve Type Code No.		TABLE C Body Material Code No. Material		TABLE D* Connections Code No. End Type	
1-1/2 (40)		BO	Standard	C	Cast Iron	F	ANSI B16.1 Class 125 FF Flange
2 (50)		BM	Manual Override	S	Steel	J	ANSI B16.5 Class 150 RF Flange
2-1/2 (65)		BC	Tee config, Flanged 1-1/2, 2" only	B	Bronze	H	ANSI B16.34 Class 300 RF Flange
3 (80)		BF	Flanged, 2" only	D	Ductile Iron	A	ND6 (Metric) Flange
4 (100)		BH	1-1/2, 2" only	R	Stainless Steel	B	ND10 (Metric) Flange
5 (125)		BR	Manual override (UK)			C	ND16 (Metric) Flange
6 (150)						N	Navy Flange
8 (200)						P	JIS 5K FF Flange
						T	NPT Threaded
						V	BSP-TR / JIS Threaded
						W	SAE Threaded (straight thread, O-ring seal)

TABLE E Temperature Setting Code No. Nominal Temp °F (°C)			TABLE E (Continued) Temperature Setting Code No. Nominal Temp °F (°C)		
*055	55	(13)	160	160	(71)
075	75	(24)	165	165	(74)
090	90	(32)	170	170	(77)
095	95	(35)	175	175	(79)
100	100	(38)	180	180	(83)
105	105	(41)	185	185	(85)
110	110	(43)	195	195	(91)
115	115	(46)	205	205	(96)
120	120	(49)	215	215	(102)
*130	130	(54)	225	225	(107)
135	135	(57)	230	230	(110)
140	140	(60)	235	235	(113)
145	145	(63)	240	240	(116)
*150	150	(66)	Temperatures apply only to 1096 and 2433 Element Assemblies.		
155	155	(69)			

TABLE F Element Assembly Code No. Element Assembly Type		
01	1096X	Standard
02	1096P	Plated with Viton
03	1096X	with Viton seals
07	2433X	Manual Override
11	5566X	Reduced stroke
05	6836S	Saltwater
44	1096X	with Neoprene
45	1096P	with Neoprene
20	5566X	with Viton
12	5566P	Plated
53	2433X	with Viton
50	6836K	Electroless Nickel with Neoprene

TABLE G Element Assembly Leak Hole Code No. Size Inches (mm)		
none (standard)		
A	1/2"	(12.5)
B	1/4"	(6.4)
C	3/8"	(9.5)
D	1/8"	(3.2)
E	1/16"	(1.6)
F	3/32"	(2.4)
G	3/16"	(4.8)
H	5/16"	(7.9)

* = Also avail. as reduced stroke. Contact factory for other temps.
 [Shaded Box] Indicates Non-Standard, MTO

DIMENSIONS

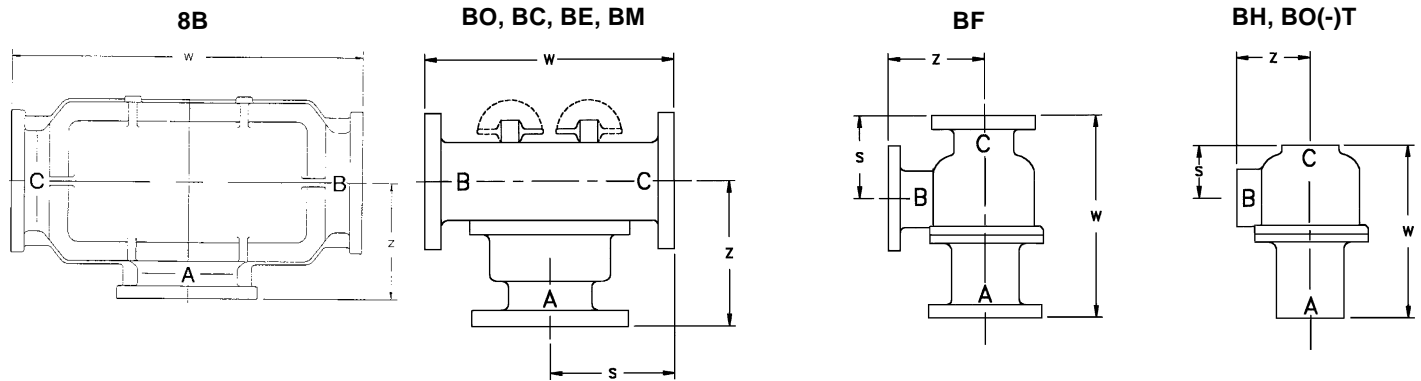

Model No.	Nominal Pipe Size	Principal Dimensions			Width in the Other Plane	Flange Drilling			No. of Element Assemblies
		"S"	"W"	"Z"		No. of Holes	Dia. of Holes	Bolt Circle	
1-1/2BO(-)T	1-1/2 (40)	3-13/16 (97)	9-11/16 (246)	3-9/16 (90)	5-1/2 (140)	—	—	—	1
1-1/2BHCT	1-1/2 (40)	4-1/16 (103)	10-11/16 (271)	4 (102)	5-3/4 (146)	—	—	—	1
2BC(-)F 2BM(-)F	2 (50)	4-7/16 (113)	8-7/8 (225)	5-7/8 (149)	6 (152)	4	3/4 (19)	4-3/4 (121)	1
2BF(-)F	2 (50)	4-3/4 (121)	10-5/8 (270)	4-7/16 (113)	6 (152)	4	3/4 (19)	4-3/4 (121)	1
2BCSJ 2BMSJ	2 (50)	4-7/16 (112)	8-7/8 (225)	5-7/8 (149)	6 (152)	4	3/4 (19)	4-3/4 (121)	1
2BCSH 2BMSH	2 (50)	4-7/16 (112)	8-7/8 (225)	5-7/8 (149)	6 (152)	8	3/4 (19)	5 (127)	1
2BO(-)T	2 (50)	3-13/16 (97)	9-11/16 (246)	3-9/16 (90)	5-1/2 (140)	—	—	—	1
2BHCT	2 (50)	4-1/16 (103)	10-11/16 (271)	4 (102)	5-3/4 (146)	—	—	—	1
2-1/2BO(-)F 2-1/2BM(-)F	2-1/2 (65)	5 (127)	10 (254)	6-1/2 (165)	8-1/4 (210)	4	3/4 (19)	5-1/2 (140)	2
2-1/2BOSJ 2-1/2BMSJ	2-1/2 (65)	5 (127)	10 (254)	6-1/2 (165)	8-1/4 (210)	4	3/4 (19)	5-1/2 (140)	2
3BO(-)F 3BM(-)F	3 (80)	5-1/4 (133)	10-1/2 (267)	6-3/4 (172)	8-1/4 (210)	4	3/4 (19)	6 (152)	2
3BOSJ 3BMSJ	3 (80)	5-1/4 (133)	10-1/2 (267)	6-3/4 (172)	8-1/4 (210)	4	3/4 (19)	6 (152)	2
3BOSH 3BMSH	3 (80)	5-1/4 (133)	10-1/2 (267)	6-3/4 (172)	8-1/4 (210)	8	3/4 (19)	6-5/8 (168)	2
4BO(-)F 4BM(-)F	4 (100)	7-15/16 (201)	15-7/8 (403)	8-9/16 (218)	12-1/8 (308)	8	3/4 (19)	7-1/2 (190)	4
5BO(-)F 5BM(-)F	5 (125)	9-5/8 (249)	19-1/4 (489)	9-1/2 (241)	13-3/4 (349)	8	7/8 (22)	8-1/2 (216)	6
6BO(-)F 6BM(-)F	6 (150)	9-5/8 (244)	19-1/4 (489)	10 (254)	19 (483)	8	7/8 (22)	9-1/2 (241)	9
8BO(-)F 8BR(-)F	8 (200)	16-1/2 (420)	33 (840)	11 (280)	19-11/16(500) 26-3/4(680)	8	7/8 (22)	11-3/4 (298)	18

Dimensions in inches. Millimeters in ().

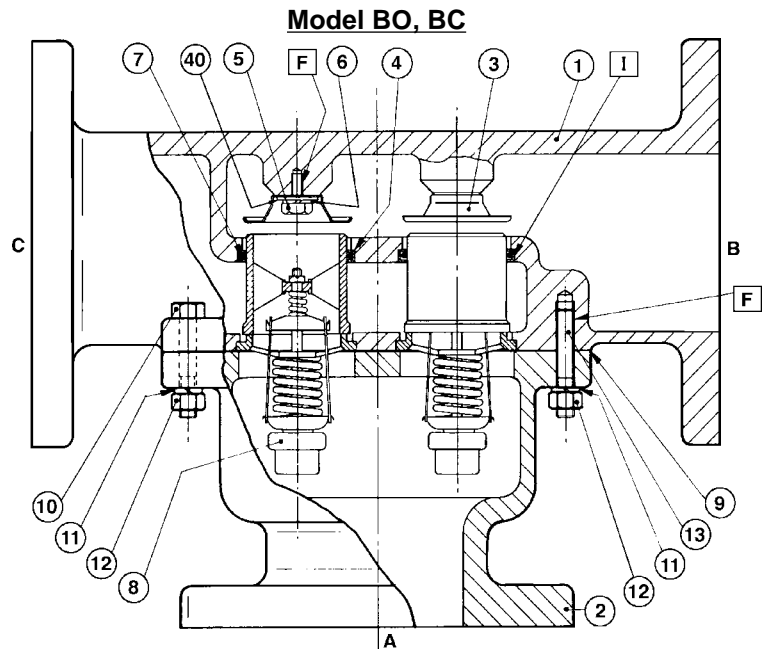
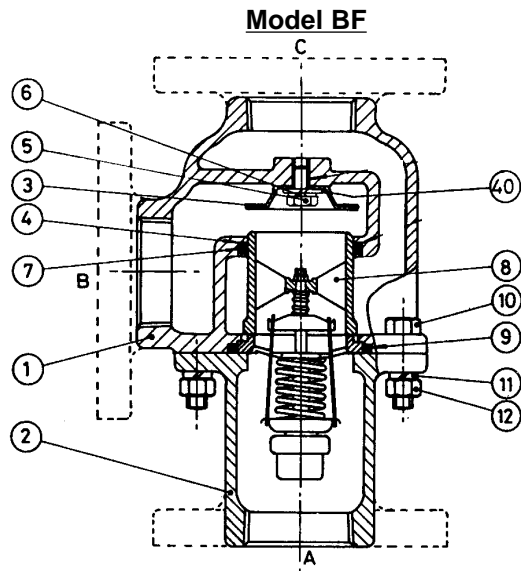

SERVICE PARTS FOR MODELS BO, BC, BF, BH, BM

Ref No.	Part No.	Description
3	9585L001	Seat, Bolted-In (Except BM)
3	9585L002	Seat (BM only)
4	1182	Sleeve
5	11132L050	Capscrew
6	11133	Lockwasher
7	1183	Element O-ring, Buna N (Standard)
7	1183L002	Element O-ring Seal, Viton
8	1096X(temp)	Element Assembly (Standard)
8	1096P(temp)	Element Assembly, plated
8	2433X(temp)	Element Assembly, manual override
9	761	O-ring 1-1/2 – 3B, Buna N
9	761L001	O-ring 1-1/2 – 3B, Viton
9	1094	Gasket 2-1/2 B, 3B, (Old Versions)
9	1123	Gasket 4B
9	1117	Gasket 5B
9	1149	Gasket 6B
17	358	O-ring, Buna N (BM only)
17	358L001	O-ring, Viton (BM only)

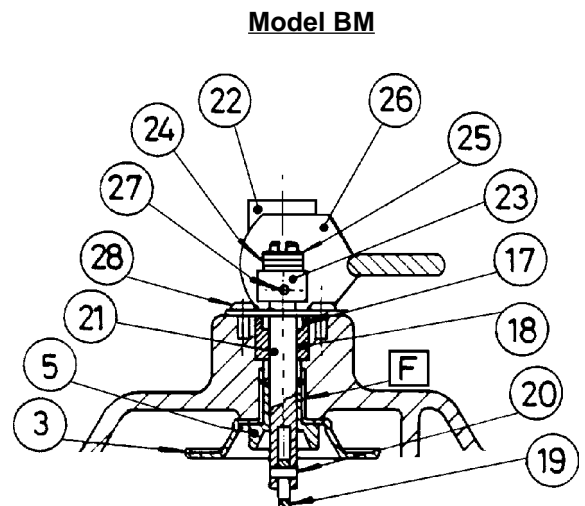

This Parts List effective with Valve Serial No. B941.

MAINTENANCE

Properly applied and installed, AMOT Thermostatic Valves require practically no maintenance.

If necessary, temperature element assemblies may be easily replaced. Remove Nuts (12) or Bolts (6) and separate the Upper (1) and Lower (2) Housing. Remove Element Assembly (8) and Element O-ring Seal (7). Remove Housing O-ring (9) or Gasket and clean any foreign material from sealing surfaces. Lubricate new Element O-ring Seal (7) with a good grade of petroleum grease and re-insert in the groove in Upper Housing (1). Insert Element Assembly (8) through Element O-ring Seal (7) with a twisting motion. Install Housing O-ring (9) or Gasket around the Element Assembly Flange and bolt on Lower Housing (2).

AMOT designs and tests all its products to ensure that high quality standards are met. For good product life, carefully follow AMOT's installation and maintenance instruction; failure to do so could result in damage to the equipment being protected or controlled.

When communicating with AMOT regarding operation of a control, always give the Model No. and Serial No. If ordering service parts, also include description, part no., and quantity desired. If any parts are ordered by Reference No. only, please include the Form No., Revision No., and date of this brochure.

AMOT USA
401 First Street
Richmond, CA 94801
Tel: +1 510 236-8300
Fax: +1 510 234-9950

AMOT
Western Way
Bury St. Edmunds IP33 3SZ
Suffolk England
Tel: +44 1284 762222
Fax: +44 1284 760256

AMOT SINGAPORE
10 Eunos Road 8 # 12-06
Singapore Post Centre
Singapore 408600
Tel: +65 6293 4320
Fax: +65 6293 3307