

Falcon Low Power Solenoid

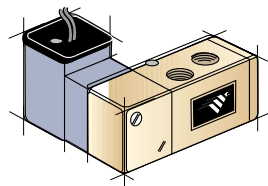

CONFORMANCE TESTED

The Falcon Low Power Solenoid is specially designed to reduce the power requirements for conventional I/O valve systems.

It offers all the reliability of a pilot operated solenoid valve with a 55% reduction in power requirements.

Rotary and linear sanitary valve monitors utilize only 20 mA @ 24VDC.

These power reductions reduce lifetime operational costs and allow for use of fewer and less expensive power supply devices.

Electrical Coil Specifications - (NEMA 4, 4x 7 ,9)	
Voltage	18-30 VDC
Coil Rating	Class F
Voltage Tolerance	-10%
Ambient Temperature	-20C to +85C
Duty Cycle	100%
Degree of Protection	IP65
Connection	Flying Leads
Power Consumption	20 mA @24 Volts DC
Pressure Range	0 - 8 Bar
Coil Part Numbers	Consult Factory
Seals and Seats Springs/Armature	Viton/Stainless Steel (others available)

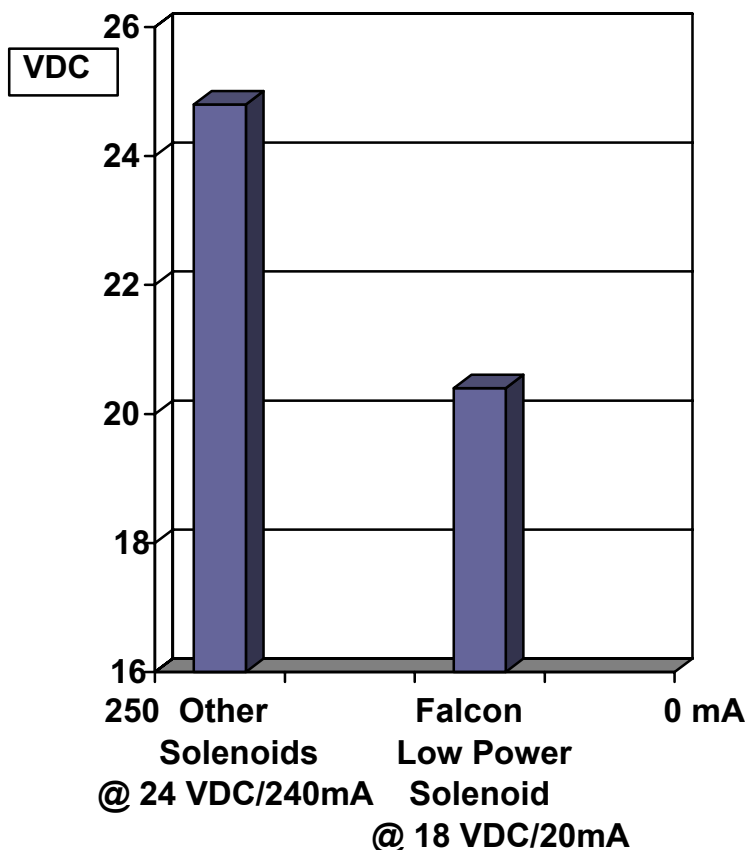

ORDERING GUIDE (FALCON® SOLENOID)

COILS	CV	Body	3-Way	4-Way
FAO 24 VAC/DC 1.5 watts	.3 Cv	Brass	2100	2500
		Alum.	3100	3500
		303 S.S.	4100	4500
		316 S.S.	5100	5500
	.5 Cv	Delrin	6100	6500
		Brass	2200	2600
		Alum.	3200	3600
		303 SS	4200	4600
	1.2 Cv	316 S.S.	5200	5600
		Delrin	6200	6600
		Brass	2300	2700
		Alum.	3300	3700
	3.5 Cv	303 S.S.	4300	4700
		316 S.S.	5300	5700
		Delrin	6300	6700
		Alum.	3400	3800
		Delrin	6400	6800

OPTIONAL FEATURES (See BULLETIN NO. Q-18.00)

WESTLOCK

CONTROLS CORPORATION

STANDARD N/I COIL DATA SHEET

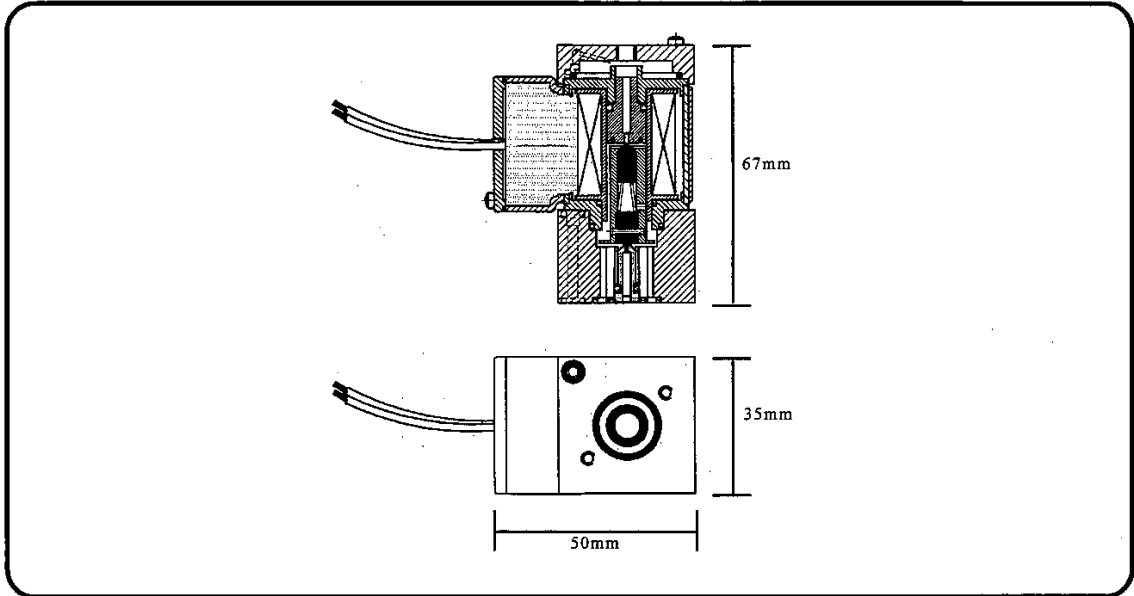

Material Specification	Standard
Coil Case	Zinc Alloy Epoxy Powder Coated
Armature and Fixed Pole Piece	Magnetic Solenoid Quality Stainless Steel
Springs	Stainless Steel
Seals and Seats	Viton
Coil Former	30% Glass Filled PBR
Magnetic Wire	Class H Coated Copper

Solenoid Specification Standard		
Type	DC Solenoid Coil	AC Solenoid
Voltage Standard	12, 24, 48, 110	24, 48, 110, 220, 415 50/60 Hz
Coil Rating	Class F	Class F
Voltage Tolerance	-10%	-10%
Ambient Temperature	-10 to +60°C	-10 to +60°C
Duty Cycle	100%	100%
Degree of Protection	IP65	IP65
Connection	Flying Leads	Flying Leads
Power Consumption	0.5 Watts	Pull in - 4VA, Holding - 3.6VA
Pressure Range	0 - 8 Bar	0 - 8 Bar

Free Standing Namur Mount

Operating Instructions for Falcon Solenoid Valve

General Description

The Falcon solenoid valve incorporates elastomer static seals through which a shaped spool moves and are manufactured for 3 or 4 way operation. 3 way is normally used for pilot control of the other relay valves or for the operation of single acting cylinders. 4 way is normally used to control the action of double acting cylinders.

The seal spacer assembly forms individual annular chambers opposite each valve port and the grooved spool either closes or allows flow between adjacent chambers, hence the position of the spool determines which ports are open or closed.

The spool is moved by way of a manually or mechanically operated mechanism normally against a return spring. Operation may be by application or removal of a pilot air supply acting as a pilot piston. This form of control is utilized for electrical actuation where integral solenoid valves control the pilot air supply.

Description of Operation

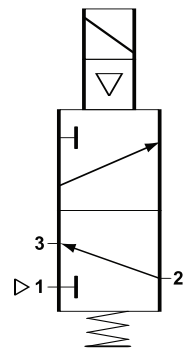

3 Way Spring Return Valve
Solenoid De-energized - air flows from Outlet Port 2 to Exhaust Port 3.
Solenoid Energized - air flows from Inlet Port 1 to Outlet Port 2.

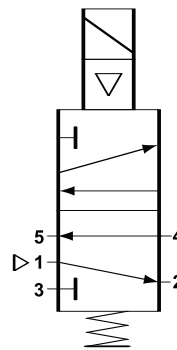

4 Way Spring Return Valve
Solenoid De-energized - air flows from Inlet Port 1 to Outlet Port 2 and exhausts from Port 4 to Port 5.
Solenoid Energized - air flows from Inlet Port 1 to Outlet Port 4 and exhausts from Port 2 to Port 3.

Optional Features

N - No-Voltage Release (Latching)

With the coil first energized, the palm button is then manually moved and latched. The inward movement of the palm button causes the valve to shift. When the coil is de-energized, the palm button and latching mechanism are automatically tripped, allowing the valve to return to its original position. (1.2 Cv Valves only) See Fig. 1

R - No-Voltage Release (Non-Latching)

With the coil first energized, the palm button is then manually moved. The inward movement of the palm button causes the valve to shift. When the coil is de-energized, the palm button automatically returns to its original position. (1.2 Cv Valves only) See Fig. 2

L - Manual Locking Override

Manually depress palm button and rotate clockwise for maintained condition, must manually disengage to return to original position. See Fig. 3

M - Momentary Override

Spring return momentary pushtype, must hold in to actuate. See Fig. 4

E - External Pilot

The 1/8" NPT external pilot connection requires a separate auxiliary pressure line to the valve. This feature should be used when the controlled pressure is below the minimum 45 psi operating pressure.

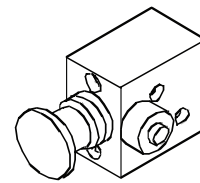

Figure 1

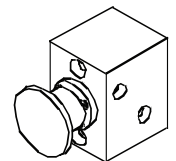

Figure 2

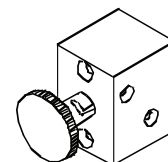

Figure 3

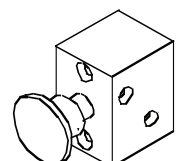

Figure 4