

# Temperature Sensors and Accessories (English)

- *Standard Immersion Sensors*
- *Available with Many Standard Process Connections*
- *Calibration Capabilities*



## Content

Introduction . . . . .	page 2
Threaded Mount Sensors and Assemblies . . . . .	page 10
Ordering Tables	
Series 68 RTD Sensor Assemblies WITHOUT Thermowell. . . . .	page 13
Series 68 RTD Sensor Assemblies WITH Thermowell . . . . .	page 15
Series 78 RTD Sensor Assemblies WITHOUT Thermowell. . . . .	page 20
Series 78 RTD Sensor Assemblies WITH Thermowell . . . . .	page 22
Series 68Q Sanitary Platinum RTD Sensor Assemblies . . . . .	page 27
Series 58C Cut-to-Fit RTD Sensors. . . . .	page 29
Series 58C Spare Parts List. . . . .	page 29
Series 183 Thermocouple Sensor Assemblies WITHOUT Thermowell. . . . .	page 31
Series 183 Thermocouple Sensor Assemblies WITH Thermowell . . . . .	page 33
Calibration . . . . .	page 37
Mounting Accessories . . . . .	page 49
Ordering Tables	
Connection Head Model Numbers. . . . .	page 50
Extension . . . . .	page 51
Compression Fittings, 316 SST . . . . .	page 52
Series 91 Thermowells. . . . .	page 57
Hazardous Area Approvals . . . . .	page 66
Configuration Data Sheet . . . . .	page 72

# Sensors and Accessories (English)

## Introduction

### OVERVIEW

Emerson Process Management offers a wide variety of RTD and thermocouple sensors that are available alone or as complete assemblies including connection heads, thermowells, and extension fittings. In addition to complete assemblies, Emerson Process Management offers heads, coupling/nipple and union/nipple extensions, compression fittings, and thermowells.

### Using this Product Data Sheet (PDS)

Use this PDS to order complete temperature sensor assemblies, which include sensors, thermowells, extensions, and connection heads. These options can also be ordered separately. For example, you can order a thermowell, extension, or connection head for use with an existing sensor. In each case it is important to know and understand the sections of this PDS when specifying the items.

### Threaded Sensors and Assemblies

- Includes descriptions, specifications, and ordering information for Series 58C, 68, 68Q, and 78 RTDs, and the Series 183 thermocouples.
- Includes information for ordering sensors, connection heads, extensions, and thermowells as complete assemblies.

### Calibration

- Includes characterization schedules and information for ordering calibrated Series 68, 68Q, and 78 RTD Sensors.
- Includes information regarding the use of Callendar-Van Dusen constants to match specific Series 68, 68Q, and 78 RTDs to Rosemount Smart Temperature Transmitters.

### Mounting Accessories

- Includes descriptions, specifications, and ordering information for temperature accessories such as thermowells, extensions, connection heads, mounting adapters, lead wire extensions, connectors, seals, and thermowells.

### Hazardous Area Approvals

- Includes descriptions of the FM, CSA, SAA, and ATEX approvals for sensors and connection heads.

### Configuration Data Sheet

- Provides a form used for thermowell application calculations.

Series 58C, 68, 68Q, and 78 platinum RTD temperature sensors are primarily used when high accuracy, durability, and long-term stability are required. These sensors conform to international standards: IEC-751, EN 60751, and BS EN 60751.<sup>(1)</sup>

Series 58C platinum RTD temperature sensors:

- Combine an economical thin-film design with a sheath that can be shortened to any length with tubing cutter.

Series 68Q Quick Response Sanitary RTD sensors:

- Conform to 3-A Sanitary Standards and feature product contact surfaces designed for CIP cleaning.

Series 68 platinum RTD temperature sensors:

- Provide high performance in an economical thin-film design.

Series 78 platinum RTDs temperature sensors:

- Use a wire-wound element which allows for a broader measurement range.

### Thermocouples

Series 183 thermocouple temperature sensors conform to ASTM E-230, and are available in types J, K, E, and T.

Series 183 thermocouple temperature sensors are available:

- grounded or ungrounded
- isolated or unisolated
- with immersion lengths from 2 to 48 inches.

(1) 100 ohms at 0 °C,  $\alpha = 0.00385 \text{ ohms/ohm}^{\circ}\text{C}$

## The Use of 2-, 3-, and 4- wire RTDs

To help you attain the highest possible temperature measurement accuracy, Rosemount provides 4-wire sensors for all single element RTDs. You can use these RTDs in 2-, 3-, or 4-wire configurations by simply securing the unneeded leads with tape. To properly wire the 4-wire RTD for use in a 2-, 3-, or 4-wire configuration, refer to the following wiring diagrams:

### 2-wire Configuration

2-wire RTDs provide one connection to each end of the sensor. In a 2-wire configuration, lead wires add resistance to the circuit which cannot be compensated. The 2-wire configuration is rarely used because the added lead wire resistance can cause substantial errors in the temperature reading.

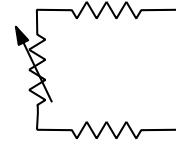

### 3-wire Configuration

3-wire RTDs provide one connection to one end of the sensor, and two connections to the other end. The 3-wire approach does not eliminate all lead wire effects. However, for sensors with lead wires of the same length, lead wire effects are slight, and the approach provides reasonable accuracy.

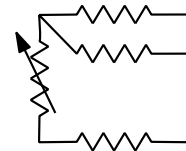

### 4-wire Configuration

The most effective way to eliminate lead wire effects is with two connections at each end of the sensor. 4-wire RTDs fully compensate for lead wire effects.

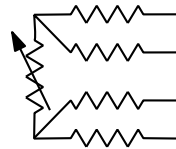

## Benefits and Limitations of RTDs when compared to Thermocouples

### Benefits:

- Higher accuracy
- Better linearity and long-term stability
- Cold junction compensation not required
- Special extension lead wire not required
- Less susceptible to noise
- Can be "matched" to a Rosemount transmitter with transmitter sensor matching

### Limitations

- Lower maximum temperature limit
- Slower response time in applications without a thermowell

# Sensors and Accessories (English)

## HOW TO DECIDE WHAT TO ORDER

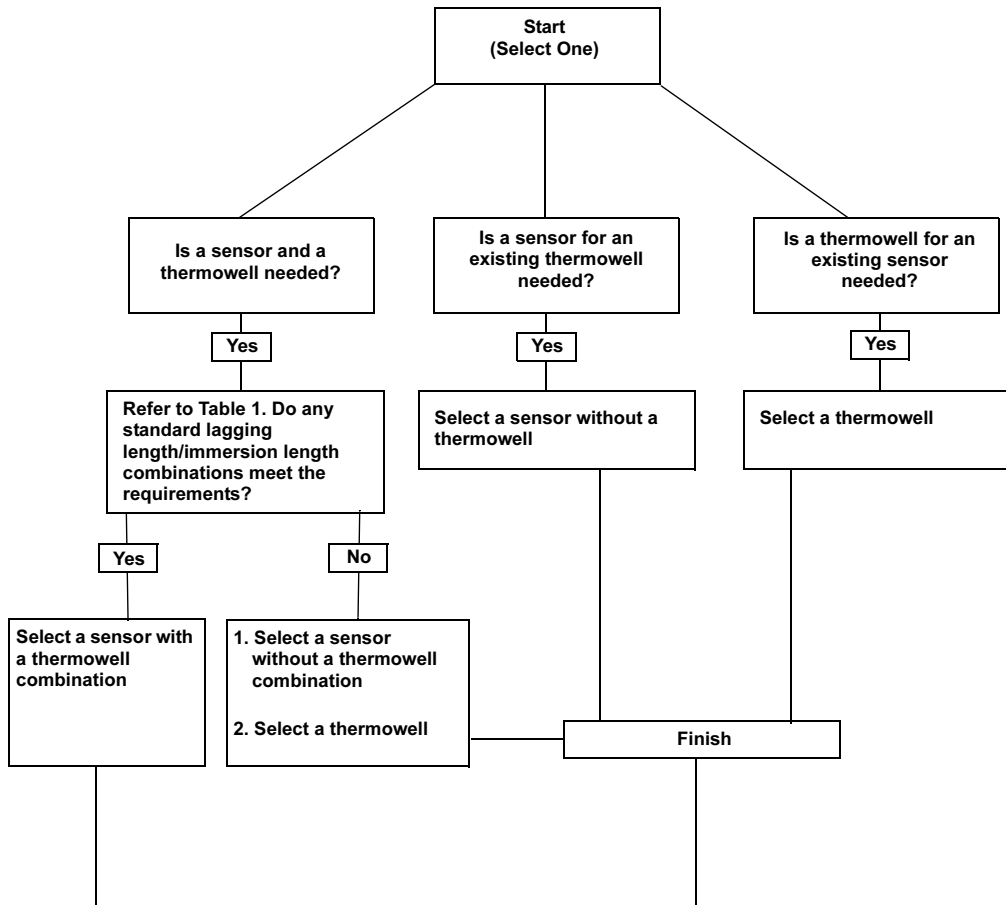

### If Rosemount sensor and model code is visible on the Sensor:

1. If the thermowell is ordered separately (0078P23C30N060) 11th digit = 'N'

- a. Start with immersion length - digits 12-14; 060 = 6.0 in.
- b. Add extension length - digits 9 & 10; 30 = 3.0 in. (3 + 6 = 9)

**Order** the replacement sensor for the total length without connection heads (5th digit **N**) and extension (8th digit **N**) 0078N23N00N090

2. If the thermowell is ordered integral to sensor (0078P23C30A060W40) 11th digit = not 'N'

- a. Immersion length 'U' is defined by the 12-14th digits; 060 = 6.0 in.
- b. Look up 'L' length from the correct order chart for given 'U' length. This will be 4 inches for short sensors, or a whole number divisible by 3 for sensors longer than 4 inches (4, 6, 9, 12, 15, 18... inches);  
'U' 060 = 9 inches 'L'
- c. Add extension length as defined by 9th and 10th digits; 30 = 3.0 in. to the 'L' length found in table.  
(9" + 3" = 12", Length code 120)
- d. This will be the replacement sensor length 'X'.

**Order** sensor without connection head (5th digit **N**) or extension (8th digit **N**) 0078N23N00N120

## Product Data Sheet

00813-0100-2654, Rev GA

March 2008

# Sensors and Accessories (English)

### If model code is NOT visible on the sensor, follow one of the three instructions below:

1. Measure the inside depth of the thermowell \*preferred\*
  - a. Measure down the inside of the thermowell hole to the top-most face of the extension used, or the thermowell if no extension
  - b. This will be the replacement sensor length if depth = 12.0 in., sensor length will be 12 in.

**Order** sensor without connection heads (5th digit **N**) or extension (8th digit **N**) 0078**N**23**N**00**N**1**20**

2. Measure the overall outside length of the thermowell from end to end.
  - a. Measure down the outside of the thermowell from the tip to the end face of the extension if used, or the thermowell if no extension.
  - b. Subtract 1/4 in. to account for thickness of the thermowell at the tip.
  - c. This will be the replacement sensor length. Overall length = 12.25 in., the replacement will be 12 in.

**Order** sensor without connection heads (5th digit **N**) or extension (8th digit **N**) 0078**N**23**N**00**N**1**20**

3. Measure the old sensor length from tip to the flat face of the threaded process connection.
  - a. Determine if the sensor is spring loaded or general purpose (welded) where the sensor sheath meets the threaded adaptor.
  - b. For spring loaded sensors, the measurement of the exposed sheath from tip of the start of the threaded portion will be the same as the replacement sensor length.
    - Normal spring compression for a Rosemount sensor is assumed to be 1/2 in. and the normal thread engagement is also assumed to be 1/2 in.
    - Round to the nearest whole 1/4 in. increment as the spring will make up any small differences
    - Replacement sensor for a spring loaded sensor measuring 6.5 inches will be 6.5 in. length

**Order** sensor without connection heads (5th digit **N**) or extension (8th digit **N**) 0078**N**15**N**00**N**0**65**

- c. For general purpose sensors with the distance from tip to threaded adapter:
  - Add 1/4 in. to allow clearance, preventing bottoming sensor during installation.
  - Add 1/2 in. for the thread engagement of the sensor in the thermowell.
  - The replacement sensor for a general purpose sensor measuring 5.75 in. from the tip to the threaded adaptor is 6.5 in. ( $5\frac{3}{4} + \frac{1}{4} + \frac{1}{2} = 6\frac{1}{2}$  in).

**Order** sensor without connection heads (5th digit **N**) or extension (8th digit **N**) 0078**N**15**N**00**N**0**65**

### If model code is visible on the thermowell (0091A060W40T015P) follow the instructions below to determine sensor model number:

- a. Start with immersion length digits 6-8, 060 = 6.0 in.
- b. Add additional lagging length digits 13-15, 015 = 1.5 in.
- c. To those lengths add 1.5 in. (this is the additional standard lagging length on all Rosemount thermowells) 1.75 in. minus (0.25 in. thermowell tip thickness) = 1.50 in.
- d.  $6.0 + 1.5 + 1.5 = 9$  in.

**Order** replacement sensor 0078**N**23**N**00**N**0**90**

# Sensors and Accessories (English)

## SPRING-LOADED SENSOR DIMENSIONS

When a spring-loaded sensor is used properly, the spring should be compressed approximately 1/2-inch. Therefore, all measurements of spring-loaded sensors are made with the spring compressed. If you measure an existing spring-loaded sensor while it is in a relaxed state, you must subtract 1/2-inch to arrive at the installed length (X) that must be ordered. See Figure 1.

FIGURE 1. Spring Loaded Sensors Dimensions

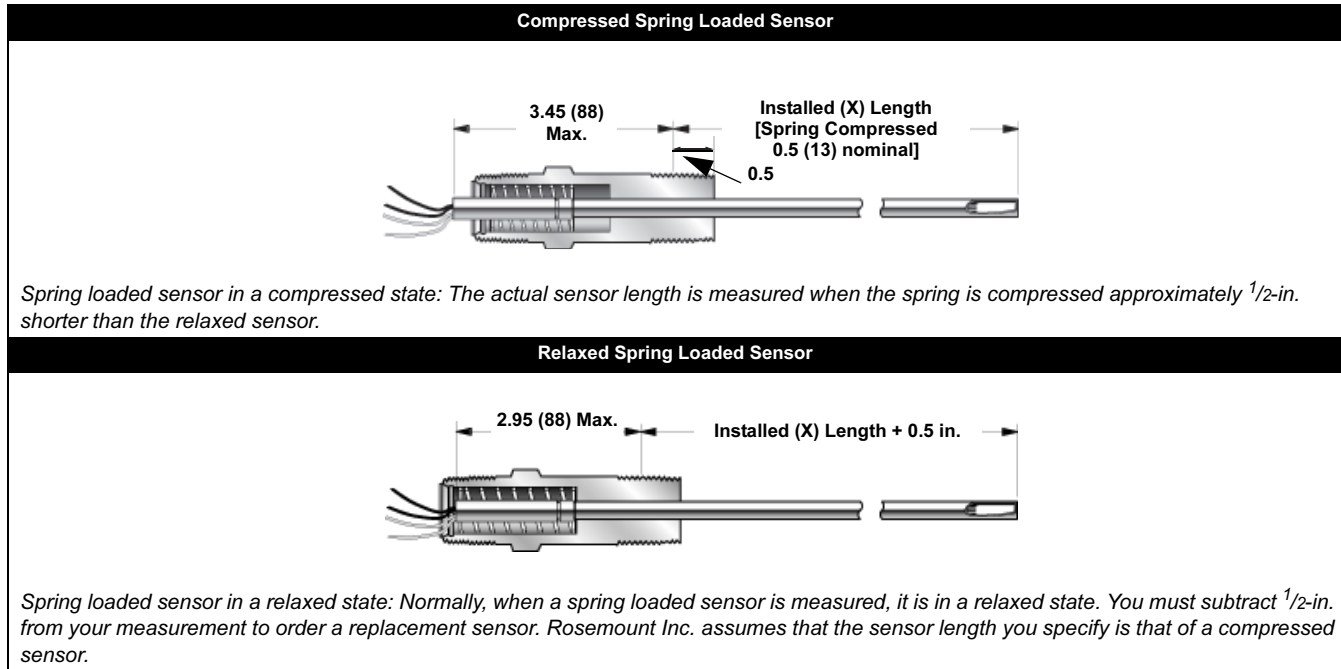

### Determining the Length (L) of a spring-loaded sensor to be used with an existing non-Rosemount Thermowell

See Figure 1, Figure 3, and Figure 4.

1. Remove the existing generic sensor from the installed thermowell.
2. Measure the sensor length with the spring in the relaxed state (as shown in Figure 1). Measure from the tip of the sensor to the maximum thread engagement point (0.53 in. into the threads).
3. Subtract 0.5 inches from your measurement. The resulting length is (X).
4. If the sensor is installed with an extension, measure the extension length (E), as shown in Figure 4. If the sensor is not installed with an extension, let (E) = 0.
5. Since (X) = (E) + (L), subtract (E) from (X) to find (L).

Use the resulting length (L) in the Section 2 ordering tables to choose the correct length of sensor.

#### Length Code Key

- L Thermowell length minus 0.25 in.
  - U Immersion length into process
  - T Lagging length
  - E Extension fitting length
  - X Sensor length
- Use the following equations to determine all lengths

$$L = U + T + 1.5$$

$$X = E + L$$

$$X = E + U + T + 1.5$$

FIGURE 2. Thermowell Dimensions (use with Table 1)

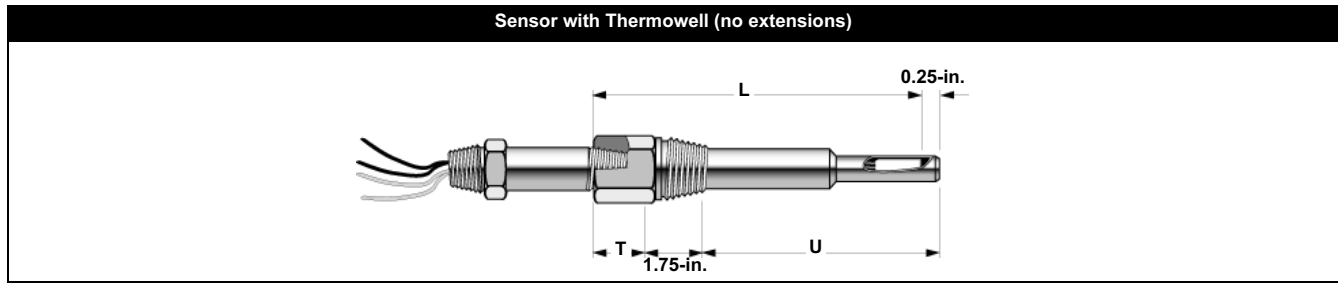

TABLE 1. Dimensions for thermowells when ordered with sensors (U), (L), and (T). Use with Figure 2.

Dimensions (in.) <sup>(1)</sup>											
Code	(U)	(L)	(T)	Code	(U)	(L)	(T)	Code	(U)	(L)	(T)
020	2.0	4.0	0.5	090	9.0	12.0	1.5	160	16.0	18.0	0.5
025	2.5	4.0	0.0	095	9.5	12.0	1.0	165	16.5	18.0	0.0
030	3.0	6.0	1.5	100	10.0	12.0	0.5	170	17.0	21.0	2.5
035	3.5	6.0	1.0	105	10.5	12.0	0.0	175	17.5	21.0	2.0
040	4.0	6.0	0.5	110	11.0	15.0	2.5	180	18.0	21.0	1.5
045	4.5	6.0	0.0	115	11.5	15.0	2.0	185	18.5	21.0	1.0
050	5.0	9.0	2.5	120	12.0	15.0	1.5	190	19.0	21.0	0.5
055	5.5	9.0	2.0	125	12.5	15.0	1.0	195	19.5	21.0	0.0
060	6.0	9.0	1.5	130	13.0	15	0.5	200	20.0	24.0	2.5
065	6.5	9.0	1.0	135	13.5	15.0	0.0	205	20.5	24.0	2.0
070	7.0	9.0	0.5	140	14.0	18.0	2.5	210	21.0	24.0	1.5
075	7.5	9.0	0.0	145	14.5	18.0	2.0	215	21.5	24.0	1.0
080	8.0	12.0	2.5	150	15.0	18.0	1.5	220	22.0	24.0	0.5
085	8.5	12.0	2.0	155	15.5	18.0	1.0	225	22.5	24.0	0.0

(1)  $L = U + T + 1.5$

### Ordering a Sensor and a Thermowell

See Figure 2 and Table 1 and Figure 3 and Figure 4. Use the following Procedure to determine if a standard lagging length can be use with the sensor and thermowell.

- Determine the (U), (T), and (E) lengths necessary for your installation.  
 If you do not need an extension, (E) = 0 (zero).  
 Note: If your existing sensor/thermowell combination is different than Figure 3, refer to the drawings on the following pages.
- Find your immersion length (U) on Table 1 above and compare the corresponding lagging length (T) to the lagging length that you previously determined.
- If your lengths match the values on the line that corresponds to your required immersion length, order your sensor and thermowell together.

If your lengths do not match the values on the line that corresponds to your measured immersion length, order your sensor and thermowell separately. Solve for (L) using the equation  $(L) = (U) + (T) + 1.5$  (since (L) is required when ordering the sensor separately from the thermowell).

#### Length Code Key

- L Thermowell length minus 0.25 in.
- U Immersion length into process
- T Lagging length
- E Extension fitting length
- X Sensor length

Use the following equations to determine all lengths

$$L = U + T + 1.5$$

$$X = E + L$$

$$X = E + U + T + 1.5$$

FIGURE 3. Series 68, 78, and 183 Sensor Assembly Dimensional Drawings

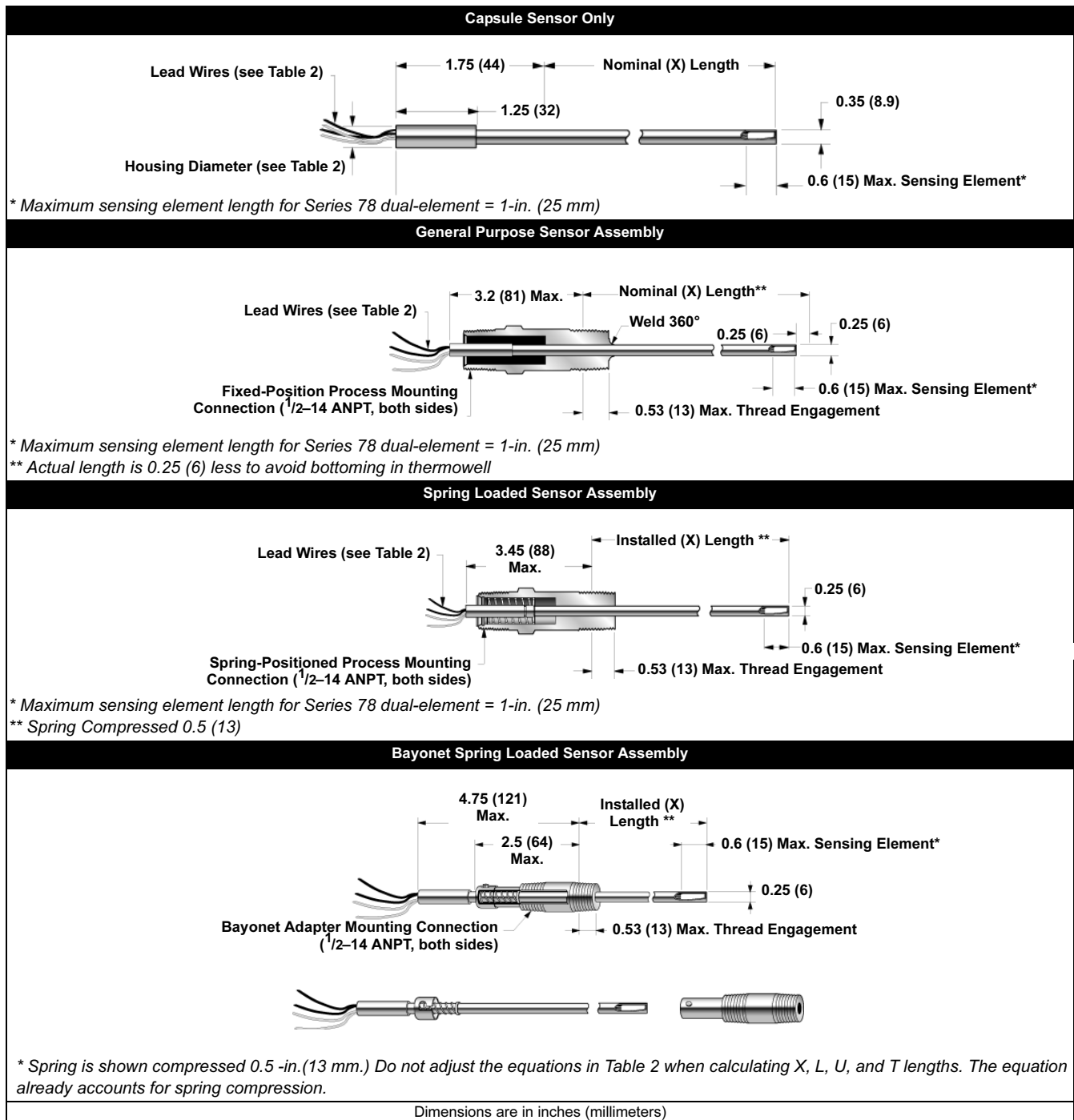
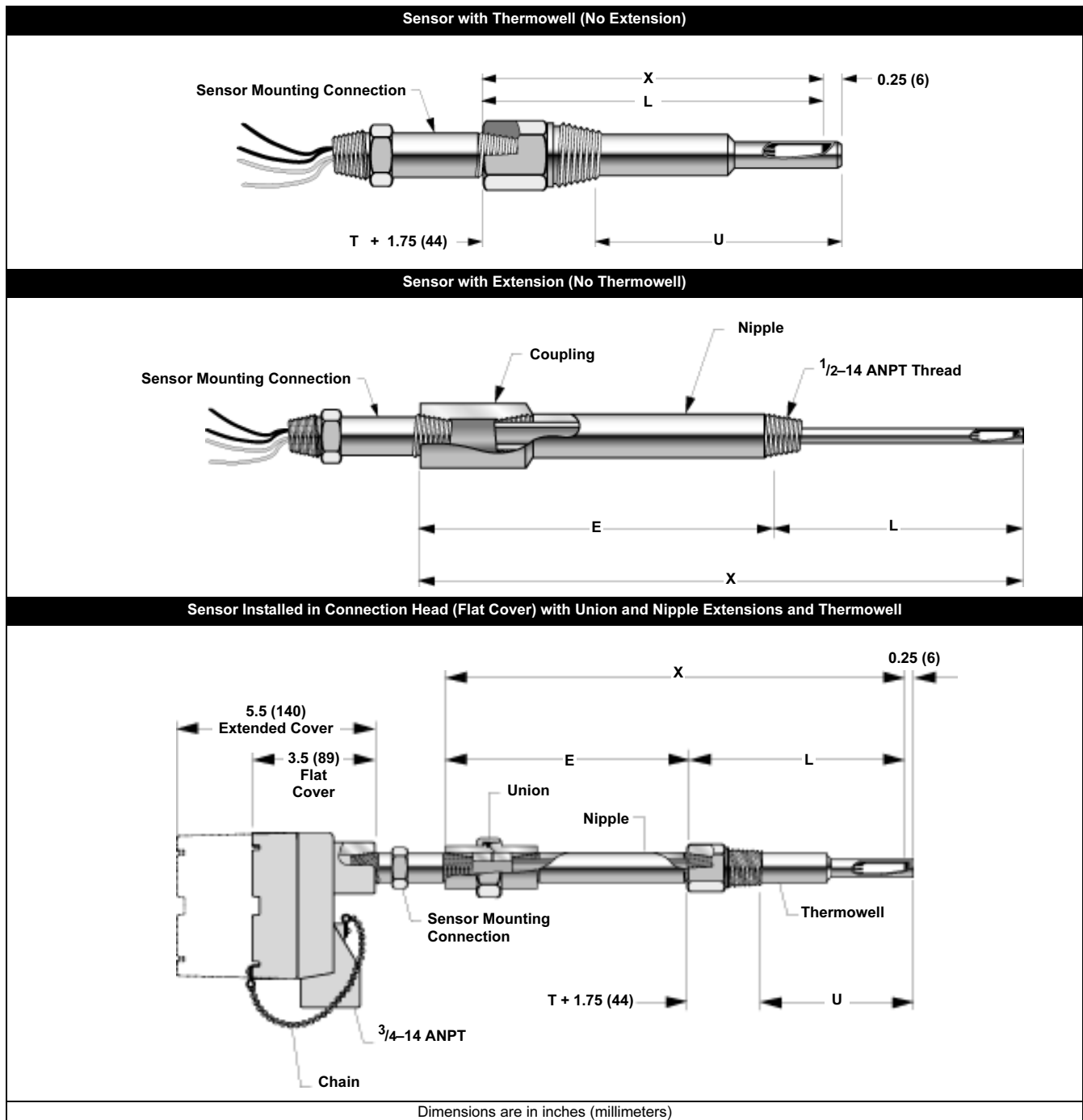

TABLE 2. Sensor Series and Dimensions

Series	Housing Diameter		Lead Wires	Lead Wire Length	
	in	mm		in	mm
68	0.350	8.0	4	6.0	152.4
78 single	0.350	8.0	4	6.0	152.4
78 dual	0.350	8.0	6	6.0	152.4

Series	Housing Diameter		Lead Wires	Lead Wire Length	
	in	mm		in	mm
183 single	0.375	9.53	2	6.0	152.4
183 dual	0.375	9.53	4	12.0	304.8

FIGURE 4. Series 68, 78, and 183 Sensor Assembly Length Code Drawings



## Threaded Sensors and Assemblies

Series 68, 68Q, and 78 RTD and Series 183 Thermocouple Sensors may be ordered as complete assemblies. These assemblies provide a complete, yet simple means of specifying the proper industrial hardware for most temperature measurements.

One assembly model number, derived from one ordering table, completely defines the type of sensing element, as well as the material, length, and style of both the extension fittings and thermowells. All sensor assemblies are sized and inspected by Rosemount Inc. to ensure complete component compatibility and performance.

FIGURE 5. Individual Components of a Complete Temperature Assembly

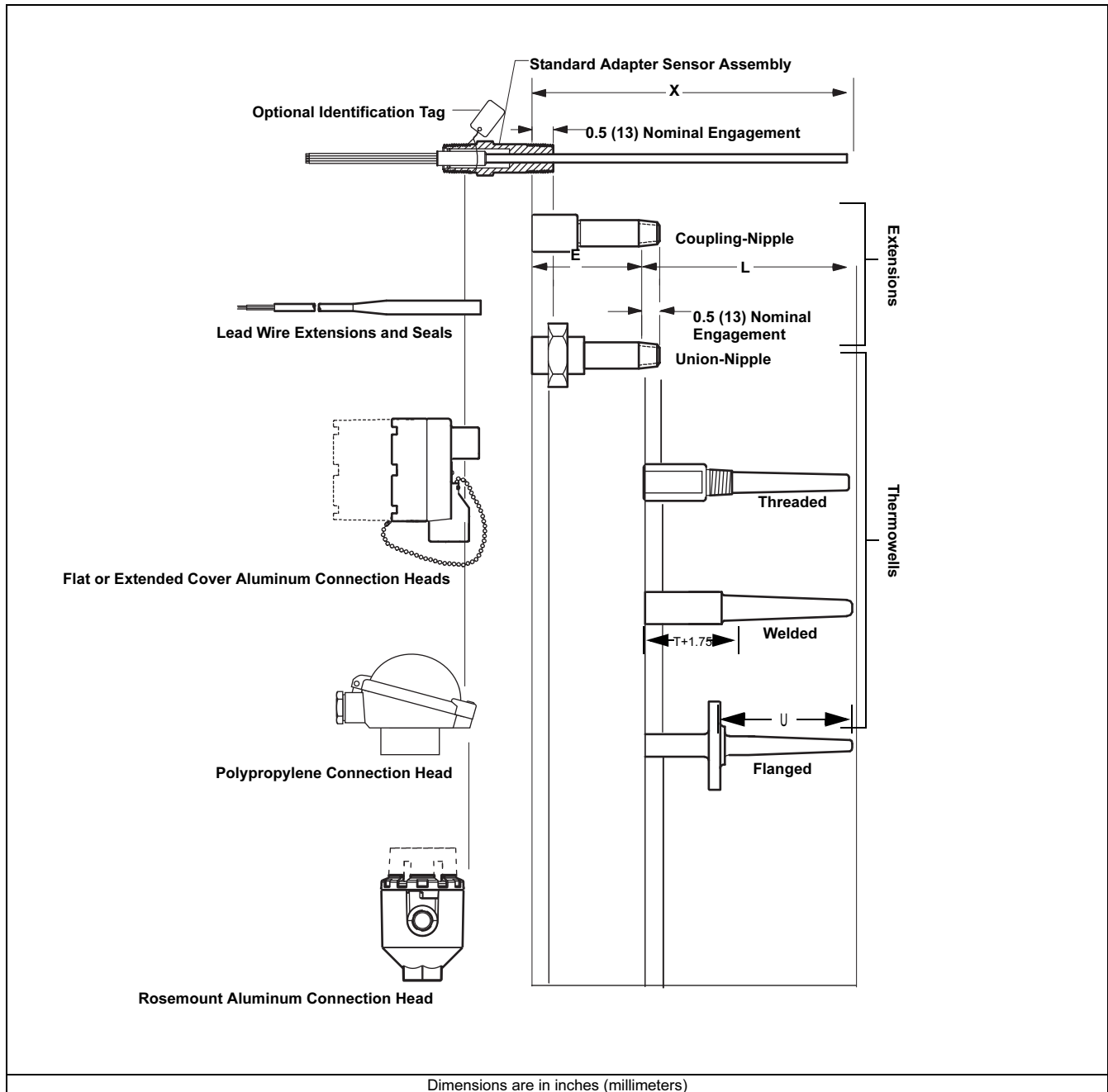

## MOUNTING CONFIGURATIONS

### Capsule

Capsules are designed for direct immersion without mounting fittings. Accessory compression fittings are available for adjustable mounting into a thermowell. See Mounting Adapters for Series 58, 68, 78, and 183.

### General-Purpose Sensor Assemblies

Designed with a welded, fixed-position  $1/2$ -14 ANPT process connection fitting for direct immersion or thermowell applications, this sensor design provides a moisture-proof and vapor-tight seal. The maximum static working pressure at 20 °C (68 °F) with no vibration or flow condition is 31.59 MPa (3,500 psig). The use of a thermowell is recommended for process pressure containment. Note that standard lengths are  $1/4$  inch less than nominal dimension to prevent bottoming of the sensor in a thermowell.

### Spring-Loaded Sensor Assemblies

Spring-loaded sensors have a spring-positioned,  $1/2$ -14 ANPT process connection fitting that ensures good surface contact in thermowells for faster time response and vibration resistance. Spring-loaded sensors are not intended to provide a process seal. They must be used in conjunction with a thermowell for this purpose.

### NOTE

When a spring-loaded sensor is used properly, the spring should be compressed approximately  $1/2$ -inch.

### Bayonet Spring-Loaded Sensor Assemblies

Bayonet assemblies have the same advantages as the spring-loaded sensor. However, the bayonet connector permits the sensor to be easily removed from the process without tools.

FIGURE 6. Series 68, 68Q, 78, and 58C Lead Wire Configurations

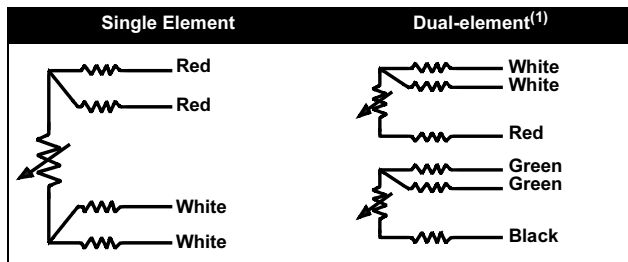

(1) Dual-element sensors are only available on Series 68Q and 78 sensors.

## SERIES 68 PLATINUM RTD

Rosemount Series 68 Platinum resistance temperature sensors measure from -50 to 400 °C (-58 to 752 °F). Series 68 Class B, Pt100-385 sensors are available in capsule, general purpose, and spring-loaded designs in sensor lengths from 1 to 48 inches.

Table 3 shows the interchangeability of the Series 68 RTD. As an option, for maximum system accuracy, Rosemount Inc. can provide sensor calibration. See Sensor Characterization (Calibration) Schedules- Option Code V. In addition, Rosemount Inc. offers optional sensor-to-transmitter matching capability obtainable through the use of Callendar-Van Dusen Constants. See Option Code "V" Callendar-van Dusen Constants.

TABLE 3. Series 68 Interchangeability

- $\pm 0.55$  °C ( $\pm 0.99$  °F) at -50 °C (-58 °F)
- $\pm 0.30$  °C ( $\pm 0.54$  °F) at 0 °C (32 °F)
- $\pm 0.80$  °C ( $\pm 1.44$  °F) at 100 °C (212 °F)
- $\pm 1.30$  °C ( $\pm 2.34$  °F) at 200 °C (392 °F)
- $\pm 1.60$  °C ( $\pm 2.88$  °F) at 260 °C (500 °F)
- $\pm 2.30$  °C ( $\pm 4.14$  °F) at 400 °C (752 °F)

### Construction

FIGURE 7. Construction of a Platinum Thin Film RTD

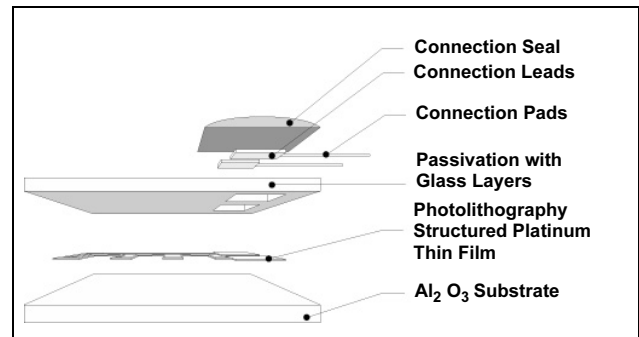

Design and construction of the Series 68 Platinum Sensors provides the optimum combination of accuracy and durability available for temperature measurements. The construction of the sensor allows for direct immersion in non-corrosive fluids at reasonable static pressures. For corrosive environments or many industrial applications, these sensors are widely used with standard thermowell assemblies.

### Platinum Element and Lead Wire Configurations

Single-element temperature sensors have four lead wires and may be used in 2-, 3-, and 4-wire signal conditioning systems.

# Sensors and Accessories (English)

---

## Specifications

### Performance

#### Temperature Range

-50 to 400 °C (-58 to 752 °F)

#### Effect of Temperature Cycling

±0.05% (0.13 °C or 0.23 °F) maximum ice-point resistance shift following 10 cycles over the specified temperature range.

#### Stability

±0.11% maximum ice-point resistance shift following 1,000 hours at maximum specified temperature (400 °C).

#### Maximum Hysteresis

±0.1% of operating temperature range.

#### Time Constant

12 seconds maximum required to reach 63.2% sensor response in water flowing at 3 ft/s (0.91 m/s).

#### Nominal R0 100 Ohm

Nominal alpha .00385 C-1

## Physical Specifications

### Sheath Material

316 SST. / 321 SST.

### Lead Wire

PTFE insulated, nickel-coated, 22-gauge stranded copper wire.

### Identification Data

The model, serial numbers, and up to six lines of permanent tagging information are etched on each sensor. Stainless steel tags are available upon request.

### Weight

- Capsule sensors: 5 oz
- General-purpose and spring-loaded sensors: 9 oz

## Environmental

### Humidity Limits

- Lead seal can withstand 100% relative humidity.

### Vibration Limits

- ±0.05% maximum ice-point resistance shift due to 30 minutes of 14 g peak vibration from 5 to 350 Hz at 20 °C (68 °F) for unsupported stem length of less than 6 inches.

### Quality Assurance

- Each sensor is subjected to a resistance accuracy test at 0 °C and a insulation resistance test.

### Enclosure Ratings

- When installed properly, Rosemount Series 68 sensors are suitable for indoor and outdoor NEMA 4X and CSA Enclosure Type 4X installations. See Hazardous Area Approvals for complete installation information.

## Insulation Resistance

1000 × 10<sup>6</sup> ohms minimum insulation resistance when measured at 500 Vdc at room temperature.

**ORDERING INFORMATION**

TABLE 4. Series 68 RTD Sensor Assemblies WITHOUT Thermowell

Model	Product Description	Available Safety Approvals			
0068	Platinum Thin-Film Temperature Sensors and Sensor Assemblies				
Code	Sensor Lead Wire Termination	FM	ATEX	CSA	SAA
D	Rosemount Aluminum Connection head	Y	Y	Y	Y
C	Polypropylene Connection Head	N	N	N	N
R	Aluminum Connection Head, Six Terminals, Flat Cover, Unpainted	Y	Y	Y	N
T	Aluminum Connection Head, Six Terminals, Extended Cover, Unpainted	Y	Y	Y	N
P	Aluminum Connection Head, Six Terminals, Flat Cover, Painted	Y	Y	Y	N
L	Aluminum Connection Head, Six Terminals, Extended Cover, Painted	Y	Y	Y	N
N	Sensor only with 6-in. PTFE -insulated, 22-gauge lead wires	Y	Y	Y	N
G	Rosemount SST Connection Head with 1/2 in. Entries	Y	Y	Y	Y
Code	Sensor Type (single element -50 to 400 °C (-58 to 752 °F))				
01 <sup>(1)(2)</sup>	Capsule Style				
11 <sup>(3)</sup>	General-purpose style				
21 <sup>(4)</sup>	Spring-loaded style				
31 <sup>(5)</sup>	Bayonet spring-loaded style (available in 1-in. increments from 1 to 21 inches)				
Code	Extension Type	Material			
A	Nipple Coupling	SST			
C	Nipple Union	SST			
N	None	(Use with extension length option code 00)			
Code	Extension Length (E)				
00	0.0 in.				
30	3.0 in. (X) sensor length = (E) extension length + (L) thermowell length minus 0.25 in. (see Figure 4.)				
60	6.0 in.				
Code	Thermowell Material				
N	No thermowell required				
Code	Immersion Length (L)	Code	Immersion Length (L)	Code	Immersion Length (L)
010 <sup>(1)(6)</sup>	1.0-in.	130	13.0-in.	250	25.0-in.
015	1.5-in.	135	13.5-in.	260	26.0-in.
020	2.0-in.	140	14.0-in.	270	27.0-in.
025	2.5-in.	145	14.5-in.	280	28.0-in.
030	3.0-in.	150	15.0-in.	290	29.0-in.
035	3.5-in.	155	15.5-in.	300	30.0-in.
040	4.0-in.	160	16.0-in.	310	31.0-in.
045	4.5-in.	165	16.5-in.	320	32.0-in.
050	5.0-in.	170	17.0-in.	330	33.0-in.
055	5.5-in.	175	17.5-in.	340	34.0-in.
060	6.0-in.	180	18.0-in.	350	35.0-in.
065	6.5-in.	185	18.5-in.	360	36.0-in.
070	7.0-in.	190	19.0-in.	370	37.0-in.
075	7.5-in.	195	19.5-in.	380	38.0-in.
080	8.0-in.	200	20.0-in.	390	39.0-in.
085	8.5-in.	205	20.5-in.	400	40.0-in.
090	9.0-in.	210	21.0-in.	410	41.0-in.
095	9.5-in.	210	21.5-in.	420	42.0-in.
100	10.0-in.	220	22.0-in.	430	43.0-in.
105	10.5-in.	225	22.5-in.	440	44.0-in.
110	11.0-in.	230	23.0-in.	450	45.0-in.
115	11.5-in.	235	23.5-in.	460	46.0-in.
120	12.0-in.	240	24.0-in.	470	47.0-in.
125	12.5-in.	245	15.5-in.	480	48.0-in.
Code	Options				
Product Certifications					
E5	FM Explosion-proof approval (See Figure 26)				
E6	CSA Explosion-proof approval (See Figure 27)				
E7 <sup>(7)</sup>	SAA Flameproof approval (See Figure 30)				

Ordering Options Continued on Next Page

# Sensors and Accessories (English)

Code	Options
V1-V7	Choose from "option code "V"-Callendar-van Dusen Constants." See Option Code "V" Callendar-van Dusen Constants. Option code V4 is not available with Series 68 sensors.
X8Q4	Calibrate to customer-specified temperature range (See Option X8Q4: Sensor Calibrated to a Customer-Specified Temperature Range)
X9Q4	Calibrate to customer-specified single temperature point (See Option X9Q4: Sensor Calibrated to a Customer-Specified Single Point)
<b>Mounting Adapters, Lead Wire Extensions, Connectors, and Seals</b>	
M5-M7	Mounting adapters
A1-A8	Twisted lead wire extensions
B1-B8 <sup>(8)</sup>	Shielded cable lead wire extensions
C1-C8 <sup>(8)</sup>	Armored cable lead wire extensions
D1-D8 <sup>(8)</sup>	Armored cable lead wire extensions with electrical plugs
L1-L8	Armored cable mating plugs with lead wire extensions
F1	4-pin bayonet connector
H1-H8	4-pin connector mating plugs with lead wire extensions
J1	Moisture-proof seal assembly for armored cables
XA <sup>(9)</sup>	Assemble connection head or transmitter to a sensor assembly (PTFE paste where appropriate, fully wired.)

- (1) Capsule style available in 1-in. increments only, starting at 1-in. (i.e. 1, 2, 3-inches, etc.) See "Mounting Adapters for Series 58, 68, 78, and 183" on page 52.
- (2) This option must be used with Sensor Lead Wire Termination code N and is not available with assembly code XA or with Approval codes E1, E5, E6, and E7.
- (3) General-purpose sensors are only available in (L) lengths of 2.5-in. or greater.
- (4) Spring loaded sensors must be installed in a thermowell assembly to meet the requirements of explosion-proof approvals code E6.
- (5) Not available with Sensor Lead Wire Termination codes R, P, or C or with approval codes E1, E5, E6, or E7.
- (6) 1-in. length without extension is only available in capsule style.
- (7) SAA Flame-proof Approval is only applicable if installed with Rosemount 248, 644, or 3144P transmitters.
- (8) These options are not available with Sensor Lead Wire Termination codes R, P, or W.
- (9) If ordering code XA with a transmitter, specify the same option on the transmitter model code.

## Ordering Example

Typical Model Number	Model	Lead Wire Termination	Sensor Type	Extension Type	Extension Length	Thermowell Material	Immersion Length	Additional Options
		0068	N	11	N	00	N	045

TABLE 5. Series 68 RTD Sensor Assemblies WITH Thermowell

Model	Product Description	Available Safety Approvals									
0068	Platinum Thin Film Temperature Sensors and Sensor Assemblies	FM	ATEX	CSA	SA						
Code	Sensor Lead Wire Termination										
D	Rosemount Aluminum Connection head	Y	Y	Y	Y						
C	Polypropylene Connection Head	N	N	N	N						
R	Aluminum Connection Head, Six Terminals, Flat Cover, Unpainted	Y	Y	Y	N						
T	Aluminum Connection Head, Six Terminals, Extended Cover, Unpainted	Y	Y	Y	N						
P	Aluminum Connection Head, Six Terminals, Flat Cover, Painted	Y	Y	Y	N						
N	Sensor only with 6-in. PTFE-insulated, 22-gauge lead wires	Y	Y	Y	N						
L	Aluminum Connection Head, Six Terminals, extended Cover, Painted	Y	Y	Y	N						
G	Rosemount SST Connection Head with 1/2 in. Entries	Y	Y	Y	Y						
Code	Sensor Type (single element -50 to 400 °C (-58 to 752 °F))										
<b>Single Element Temperature Sensors</b>											
11	General-purpose style										
21	Spring-loaded style										
31 <sup>(1)(2)</sup>	Bayonet spring-loaded style (available in (X) lengths of 1 to 21-in., increments of 1-in.)										
Code	Extension Type	Material									
A <sup>(3)</sup>	Nipple Coupling	SST									
C <sup>(3)</sup>	Nipple Union	SST									
N	None	(Use with extension length option code 00)									
Code	Extension Length (E)										
00	0.0 in.										
30	3.0 in. (X) sensor length = (E) extension length + (L) thermowell length minus 0.25 in. (see Figure 4.)										
60	6.0 in.										
Code	Thermowell Material	Code	Thermowell Material								
A	Type 316 SST <sup>(4)</sup>	J	Hastelloy® C (with 304 SST flange, if flange style is ordered)								
B	Type 304 SST	L	Hastelloy B (with 304 SST flange, if flange style is ordered)								
C	Carbon Steel	M	304 SST with PTFE coating								
D	316L SST	P	Chrome Molybdenum F22								
E	304L SST	R	Nickel 200								
F	Alloy 20	T	Titanium								
G	Monel®	U <sup>(5)</sup>	316 SST with Tantalum Sheath								
H	Inconel® 600	W	321 SST								
		Z	Chrome Molybdenum F11								
Code	Length			Code	Length			Code	Length		
	U <sup>(6)</sup>	L	T <sup>(7)</sup>		U <sup>(6)</sup>	L	T <sup>(7)</sup>		U <sup>(6)</sup>	L	T <sup>(7)</sup>
015	1.5-in.	4.0-in.	1.0-in.	130	13.0-in.	15.0-in.	0.5-in.	260	26.0-in.	30.0-in.	2.5-in.
020	2.0-in.	4.0-in.	0.5-in.	135	13.5-in.	15.0-in.	0.0-in.	270	27.0-in.	30.0-in.	1.5-in.
025	2.5-in.	4.0-in.	0.0-in.	140	14.0-in.	18.0-in.	2.5-in.	280	28.0-in.	30.0-in.	0.5-in.
030	3.0-in.	6.0-in.	1.5-in.	145	14.5-in.	18.0-in.	2.0-in.	290	29.0-in.	33.0-in.	2.5-in.
035	3.5-in.	6.0-in.	1.0-in.	150	15.0-in.	18.0-in.	1.5-in.	300	30.0-in.	33.0-in.	1.5-in.
040	4.0-in.	6.0-in.	0.5-in.	155	15.5-in.	18.0-in.	1.0-in.	310	31.0-in.	33.0-in.	0.5-in.
045	4.5-in.	6.0-in.	0.0-in.	160	16.0-in.	18.0-in.	0.5-in.	320	32.0-in.	36.0-in.	2.5-in.
050	5.0-in.	9.0-in.	2.5-in.	165	16.5-in.	18.0-in.	0.0-in.	330	33.0-in.	36.0-in.	1.5-in.
055	5.5-in.	9.0-in.	2.0-in.	170	17.0-in.	21.0-in.	2.5-in.	340	34.0-in.	36.0-in.	0.5-in.
060	6.0-in.	9.0-in.	1.5-in.	175	17.5-in.	21.0-in.	2.0-in.	350	35.0-in.	39.0-in.	2.5-in.
065	6.5-in.	9.0-in.	1.0-in.	180	18.0-in.	21.0-in.	1.5-in.	360	36.0-in.	39.0-in.	1.5-in.
070	7.0-in.	9.0-in.	0.5-in.	185	18.5-in.	21.0-in.	1.0-in.	370	37.0-in.	39.0-in.	0.5-in.
075	7.5-in.	9.0-in.	0.0-in.	190	19.0-in.	21.0-in.	0.5-in.	380	38.0-in.	42.0-in.	2.5-in.
080	8.0-in.	12.0-in.	2.5-in.	195	19.5-in.	21.0-in.	0.0-in.	390	39.0-in.	42.0-in.	1.5-in.
085	8.5-in.	12.0-in.	2.0-in.	200	20.0-in.	24.0-in.	2.5-in.	400	40.0-in.	42.0-in.	0.5-in.
090	9.0-in.	12.0	1.5-in.	205	20.5-in.	24.0-in.	2.0-in.	410	41.0-in.	45.0-in.	2.5-in.
095	9.5-in.	12.0-in.	1.0-in.	210	21.0-in.	24.0-in.	1.5-in.	420	42.0-in.	45.0-in.	1.5-in.
100	10.0-in.	12.0-in.	0.5-in.	215	21.5-in.	24.0-in.	1.0-in.	430	43.0-in.	45.0-in.	0.5-in.
105	10.5-in.	12.0-in.	0.0-in.	220	22.0-in.	24.0-in.	0.5-in.	440	44.0-in.	48.0-in.	2.5-in.
110	11.0-in.	15.0-in.	2.5-in.	225	22.5-in.	24.0-in.	0.0-in.	450	45.0-in.	48.0-in.	1.5-in.
115	11.5-in.	15.0-in.	2.0-in.	230	23.0-in.	27.0-in.	2.5-in.	460	46.0-in.	48.0-in.	0.5-in.
120	12.0-in.	15.0-in.	1.5-in.	240	24.0-in.	27.0-in.	1.5-in.	470	47.0-in.	51.0-in.	2.5-in.
125	12.5-in.	15.0-in.	1.0-in.	250	25.0-in.	27.0-in.	0.5-in.	480	48.0-in.	51.0-in.	1.5-in.

Ordering Options Continued on Next Page

## Sensors and Accessories (English)

Code	Thermowell	Mounting	Stem	Tip A (in.)	Root B (in.)
T20 <sup>(4)</sup>	Threaded	1/2-14 ANPT	Stepped	0.50	0.63
T22 <sup>(4)(10)</sup>	Threaded	3/4-14 ANPT	Stepped	0.50	0.75
T24 <sup>(4)(10)</sup>	Threaded	1-11.5 ANPT	Stepped	0.50	0.88
T26 <sup>(10)</sup>	Threaded	3/4-14 ANPT	Tapered	0.63	0.88
T28 <sup>(10)</sup>	Threaded	1-11.5 ANPT	Tapered	0.63	1.06
T30 <sup>(10)</sup>	Threaded	1 1/2-11 ANPT	Tapered	0.75	1.50
T32 <sup>(10)</sup>	Threaded	1/2-14 ANPT	Straight	0.50	0.50
T34 <sup>(10)(11)</sup>	Threaded	3/4-14 ANPT	Straight	0.75	0.75
T36 <sup>(10)(11)</sup>	Threaded	1-11.5 ANPT	Straight	0.75	0.75
T38 <sup>(10)(11)</sup>	Threaded	3/4-14 ANPT	Straight	0.50	0.50
T44 <sup>(10)</sup>	Threaded	1/2-14 ANPT	Tapered	0.50	0.63
W38	Welded	3/4-in. pipe	Stepped	0.50	0.75
W40	Welded	1-in. pipe	Stepped	0.50	0.88
W42	Welded	3/4-in. pipe	Tapered	0.63	0.88
W44	Welded	1-in. pipe	Tapered	0.75	1.00
W46	Welded	1 1/4-in. pipe	Tapered	0.75	1.25
W48 <sup>(10)</sup>	Welded	3/4-in. pipe	Straight	0.75	0.75
W50 <sup>(10)</sup>	Welded	1-in. pipe	Straight	0.75	0.75
F10 <sup>(10)</sup>	Flanged	2-in., Class 150	Straight	0.75	0.75
F12 <sup>(10)</sup>	Flanged	3-in., Class 150	Straight	0.75	0.75
F52	Flanged	1-in., Class 150	Stepped	0.50	0.75
F54	Flanged	1 1/2-in., Class 150	Stepped	0.50	0.75
F56	Flanged	2-in., Class 150	Stepped	0.50	0.75
F58	Flanged	1-in., Class 150	Tapered	0.75	1.00
F60	Flanged	1 1/2-in., Class 150	Tapered	0.75	1.00
F62	Flanged	2-in. Class 150	Tapered	0.75	1.25
F64 <sup>(10)</sup>	Flanged	1-in., Class 150	Straight	0.75	0.75
F66 <sup>(10)</sup>	Flanged	1 1/2-in., Class 150	Straight	0.75	0.75
F70	Flanged	1-in., Class 300	Stepped	0.50	0.75
F72	Flanged	1 1/2-in., Class 300	Stepped	0.50	0.75
F74	Flanged	2-in., Class 300	Stepped	0.50	0.75
F76	Flanged	1-in., Class 300	Tapered	0.75	1.00
F78	Flanged	1 1/2-in., Class 300	Tapered	0.75	1.00
F80	Flanged	2-in., Class 300	Tapered	0.75	1.25
F82 <sup>(10)</sup>	Flanged	1-in., Class 300	Straight	0.75	0.75
F84 <sup>(10)</sup>	Flanged	1 1/2-in., Class 300	Straight	0.75	0.75
F86 <sup>(10)</sup>	Flanged	2-in., Class 300	Straight	0.75	0.75
F88 <sup>(8)</sup>	Flanged	1-in., Class 600	Stepped	0.50	0.75
F90 <sup>(8)</sup>	Flanged	1 1/2-in., Class 600	Stepped	0.50	0.75
F92 <sup>(8)</sup>	Flanged	2-in., Class 600	Stepped	0.50	0.75
F94 <sup>(8)</sup>	Flanged	1-in., Class 600	Tapered	0.75	1.00
F96 <sup>(8)</sup>	Flanged	1 1/2-in., Class 600	Tapered	0.75	1.00
F98 <sup>(8)</sup>	Flanged	2-in., Class 600	Tapered	0.75	1.25
F02 <sup>(10)(8)</sup>	Flanged	1-in., Class 600	Straight	0.75	0.75
F04 <sup>(10)(8)</sup>	Flanged	1 1/2-in., Class 600	Straight	0.75	0.75
F06 <sup>(10)(8)</sup>	Flanged	2-in., Class 600	Straight	0.75	0.75
F16 <sup>(8)</sup>	Flanged	1 1/2-in., Class 900	Tapered	0.75	1.00
F34 <sup>(8)</sup>	Flanged	1 1/2-in., Class 1500	Tapered	0.75	1.00
F24 <sup>(8)</sup>	Flanged	2-in., Class 1500	Tapered	0.75	1.25
F08 <sup>(8)</sup>	Flanged	1 1/2-in., Class 2500	Tapered	0.75	1.00
Q02 <sup>(9)</sup>	Sanitary, Tri-Clamp	1-in., Tri-Clamp	Stepped	0.50	0.75
Q04 <sup>(9)</sup>	Sanitary, Tri-Clamp	1 1/2-in., Tri-Clamp	Stepped	0.50	0.75
Q06 <sup>(9)</sup>	Sanitary, Tri-Clamp	2-in., Tri-Clamp	Stepped	0.50	0.75
Q08 <sup>(9)</sup>	Sanitary, Tri-Clamp	3-in., Tri-Clamp	Stepped	0.50	0.75
Q20 <sup>(9)</sup>	Sanitary, Tri-Clamp	3/4-in., Tri-Clamp	Straight	0.44	0.44
Q22 <sup>(9)</sup>	Sanitary, Tri-Clamp	1-in., Tri-Clamp	Straight	0.50	0.50
Q24 <sup>(9)</sup>	Sanitary, Tri-Clamp	1 1/2-in., Tri-Clamp	Straight	0.50	0.50
Q26 <sup>(9)</sup>	Sanitary, Tri-Clamp	2-in., Tri-Clamp	Straight	0.50	0.50
Q28 <sup>(9)</sup>	Sanitary, Tri-Clamp	3-in., Tri-Clamp	Straight	0.50	0.50
Code	Options				
Product Certifications					
E5	FM Explosion-proof approval (See Figure 26)				
E6	CSA Explosion-proof approval (See Figure 27)				
E7 <sup>(10)</sup>	SAA Flameproof approval (See Figure 30)				
E1 <sup>(11)</sup>	ATEX Flameproof approval (See Figure 29)				
Ordering Options Continued on Next Page					

# Product Data Sheet

00813-0100-2654, Rev GA

March 2008

# Sensors and Accessories (English)

Code	Options
<b>Calibration</b>	
V1-V7	Choose from "option code "V"-Callendar-van Dusen Constants." See Option Code "V" Callendar-van Dusen Constants. Option code V4 is not available with Series 68 sensors.
X8Q4	Calibrate to customer-specified temperature range (See Option X8Q4: Sensor Calibrated to a Customer-Specified Temperature Range)
X9Q4	Calibrate to customer-specified single temperature point (See Option X9Q4: Sensor Calibrated to a Customer-Specified Single Point)
<b>Thermowell Options</b>	
Q8	Thermowell material certificate
R01	Thermowell special external pressure testing
R03	Thermowell dye penetration testing
R04	Special cleaning for oxygen service
R05	Thermowell NACE approval
R06	Stainless steel plug and chain
R07 <sup>(12)</sup>	Full penetration weld
R09 <sup>(12)(13)</sup>	Concentric serrations of thermowell flange face
R10 <sup>(12)(13)</sup>	Thermowell flat faced flange
R11	Thermowell vent hole (Not available with E6 approval)
R14	Thermowell special surface finish (12 R <sub>a</sub> Max) (Maximum (U) length = 22.5 in.)
R16 <sup>(12)(13)</sup>	Ring joint flange (Not available with 0-in. (T) length)
R20	Electropolishing
R21	Thermowell Wake Frequency Calculation (Configuration Data Sheet required)
R22	Internal pressure testing
R23	Brass plug and chain
R24	CRN Marking for British Columbia
R25	CRN Marking for Alberta
R26	CRN Marking for Saskatchewan
R27	CRN Marking for Manitoba
R28	CRN Marking for Ontario
R29	CRN Marking for Quebec
R30	CRN Marking for New Brunswick
R31	CRN Marking for Nova Scotia
R32	CRN Marking for Prince Edward Island
R33	CRN Marking for Yukon Territory
R34	CRN Marking for Northwest Territory
R35	CRN Marking for Nunavut
R36	CRN Marking for Newfoundland and Labrador
R37	Thermowell from Hex stock
<b>Mounting Adapters, Lead Wire Extensions, Connectors, and Seals</b>	
M5-M7	Mounting adapters
A1-A8	Twisted lead wire extensions
B1-B8 <sup>(1)</sup>	Shielded cable lead wire extensions
C1-C8 <sup>(1)</sup>	Armored cable lead wire extensions
D1-D8 <sup>(1)</sup>	Armored cable lead wire extensions with electrical plugs
L1-L8	Armored cable mating plugs with lead wire extensions
F1 <sup>(1)</sup>	4-pin bayonet connector
H1-H8	4-pin connector mating plugs with lead wire extensions
J1	Moisture-proof seal assembly for armored cables
XA <sup>(14)</sup>	Assemble connection head or transmitter to a sensor assembly (PTFE paste where appropriate, fully wired.)

(1) Not available with Sensor Lead Wire Termination codes R, P, or W.

(2) Not available with option codes E1, E5, E6, and E7.

(3) Codes A and C must be used with an extension length. Additional non-standard (E) lengths are available in 1/2-in. increments from 2.5 to 9-in.

(4) Standard configuration with best delivery.

(5) Available only with straight stem thermowells.

(6) Thermowells with an overall length ("U" + "T" + 1.75-in.) of 36-in. or less are machined from solid barstock. Thermowells with an overall length larger than 42-in. will be constructed using a welded 3-piece design and are available only with a stepped stem style.

(7) For additional (T) lengths, see Table 28 on page Temperature-57.

(8) F88 to F08 cannot be used with 0-in. (T) length. F08 cannot be used with 0- or 1/2-in. (T) length)

(9) Limited to 24" immersion length and 316 or 304 SST materials only.

(10) SAA flame-proof approval is only applicable if installed with a Rosemount 248, 644, or 3144P transmitter.

(11) ATEX flame-proof approval is only applicable if ordered with Sensor Lead Wire Terminator code D, R, T., P or L (Rosemount connection head) or installed with Rosemount 248, 644, or 3144P transmitters.

(12) Available on flanged thermowells only.

(13) Only one flange face option allowed.

(14) If ordering option code XA with a transmitter, specify the same option on the transmitter model code.

TABLE 6. Ordering Example

Typical Model Number	Model	Lead Wire Termination	Sensor Type	Extension Type	Extension Length	Material Code	Immersion Length	Mounting Style	Additional Options
	0068	N	21	A	30	A	075	T22	E5

# Sensors and Accessories (English)

## SERIES 78 PLATINUM RTD

Series 78 sensors are intended for applications that require high accuracy, dual-elements, and/or are subjected to high temperatures. Rosemount Series 78 Platinum Resistance temperature sensors measure from -200 to 600 °C (-328 to 1112 °F). These sensors are available in capsule, general-purpose, spring-loaded, and bayonet spring-loaded designs in sensor (X) lengths from 1 to 68 inches.

Table 7 shows the interchangeability of the Series 78 Pt100-385 sensors. The performance of the standard Series 78 sensor conforms to the standard set by IEC 751 Class B. Additionally, IEC-751 Class A accuracy is available as an option. For maximum system accuracy, Rosemount Inc. can provide sensor calibration. See Sensor Characterization (Calibration) Schedules– Option Code V. Rosemount Inc. also offers optional sensor-to-transmitter matching capability obtainable through the use of Callendar-Van Dusen Constants. See Option Code “V” Callendar-van Dusen Constants and Option X8Q4: Sensor Calibrated to a Customer-Specified Temperature Range.

The wire-wound design and construction of the General-Purpose Series 78 sensor allows direct immersion in non-corrosive fluids at reasonable static pressures. For corrosive environments and in many industrial applications, these sensors are commonly used with standard thermowell assemblies.

### Platinum Element and Lead Wire Configurations

Single-element high-temperature sensors have four lead wires and may be used in 2-, 3-, and 4-wire signal conditioning systems. Dual-element sensors have redundant elements to provide separate readout and control signals from a single measurement point. Dual-element sensors have three lead wires for each element and may be used with 2- or 3-wire systems. Dual-element sensors can also be wired to be used as compensation loop sensors (see Figure 8).

FIGURE 8. Wiring Configuration of a Dual-Element Sensor to Function as a Single Element Sensor with a Compensation Loop

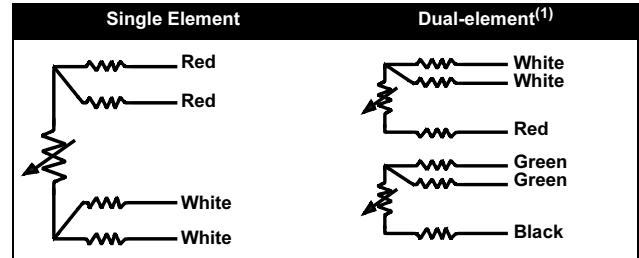

(1) Dual-element sensors are only available on Series 68Q and 78 sensors.

### Construction

FIGURE 9. Construction of a Platinum Wire-wound RTD

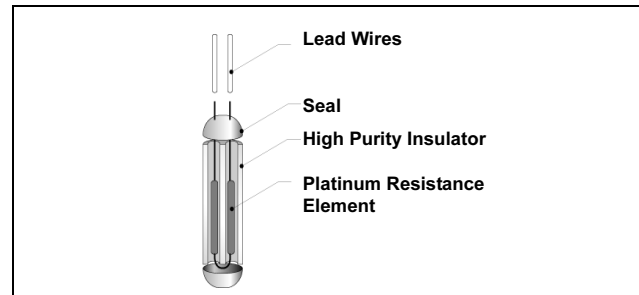

## Specifications

### Performance

#### Temperature Range

Series 78 single- and dual-element sensors may be used in temperatures from -200 to 500 °C (-328 to 932 °F). Series 78 single-element high-temperature sensors are provided for high-temperature service over the range of 0 to 600 °C (32 to 1112 °F).

#### Effect of Temperature Cycling

±0.04% (0.10 °C or 0.18 °F) maximum ice-point resistance shift following 10 cycles between -200 and 500 °C (-328 to 932 °F).

#### Stability

±0.05% maximum ice-point resistance shift following 1,000 hours at 400 °C (752 °F).

### Accuracy

TABLE 7. Series 78 Interchangeability

Standard Series 78 IEC-751 Class B	Temperature
±0.80 °C (±1.44 °F)	-100 °C (-148 °F)
±0.30 °C (±0.54 °F)	0 °C (32 °F)
±0.80 °C (±1.44 °F)	100 °C (212 °F)
±1.80 °C (±3.24 °F)	300 °C (572 °F)
±2.30 °C (±4.14 °F)	400 °C (752 °F)
Series 78 with IEC-751 Class A Option	Temperature
±0.35 °C (±0.63 °F)	-100 °C (-148 °F)
±0.15 °C (±0.27 °F)	0 °C (32 °F)
±0.35 °C (±0.63 °F)	100 °C (212 °F)
±0.75 °C (±1.35 °F)	300 °C (572 °F)
±0.95 °C (±1.71 °F)	400 °C (752 °F)

#### Maximum Hysteresis

- Single- and dual-element, Nominal R0 100 Ohm Nominal alpha .00385 Ω/Ω °C.
- Single-element, high temperature: ±0.1% of range.

#### Time Constant

4 seconds maximum required to reach 63.2% sensor response in water flowing at 3 ft/s (0.91 m/s), 9.5 seconds for single-element high-temperature sensors.

#### Self Heating

18 mW minimum power dissipation required to cause a 1 °C (1.8 °F) temperature measurement error in water flowing at 3 ft/s, 25 mW for single-element high temperature sensors.

#### Insulation Resistance

500 × 10<sup>6</sup> ohms minimum insulation resistance when measured at 500 V dc at room temperature [20 °C (68 °F)]. Single element high-temperature sensors are measured at 100V dc.

### Environmental

#### Humidity Limits

Lead seal is capable of withstanding 100% relative humidity.

#### Vibration Limits

Standard single- and dual-element sensors:

- ±0.03% maximum ice-point resistance shift due to 30 minutes of 21 g peak vibration from 5 to 350 Hz continuous sweep at 20 °C (68 °F) for unsupported stem length of less than 5.5 inches (140 mm).

Single-element high-temperature sensors:

- Meet ASTM E 1137-95. Cycling time is 3 hours per longitudinal axis, less the time spent at resonant dwells at the axis, from 5 to 500 Hz. The test level is 1.27 mm (0.05 in.) double amplitude displacement or peak g-level of 3, whichever is less.

#### Quality Assurance

Each sensor is subjected to a resistance accuracy test at 0 °C and an insulation resistance test.

#### Enclosure Ratings

When installed properly, Rosemount Series 78 sensors are suitable for indoor and outdoor NEMA 4X and CSA Enclosure Type 4X installations. See Hazardous Area Approvals for complete installation information.

### Physical Specifications

#### Sheath Material

316 SST

#### Lead Wires

PTFE-insulated, nickel-coated, 22-gauge stranded copper wire.

#### Identification Data

The model and serial numbers and up to six lines of permanent tagging information are etched on each sensor. Stainless steel tags are available upon request.

#### Weight

- Capsule sensors: 5 oz
- General purpose and spring-loaded sensors: 9 oz

# Sensors and Accessories (English)

## Ordering Information

TABLE 8. Series 78 RTD Sensor Assemblies WITHOUT Thermowell

Model	Product Description	Available Safety Approvals						
0078	Platinum Wire-Wound Temperature Sensors and Sensor Assemblies							
Code	Sensor Lead Wire Termination	FM	ATEX	CSA	SAA			
D	Rosemount Aluminum Connection head	Y	Y	Y	Y			
C	Polypropylene Connection Head	N	N	N	N			
R	Aluminum Connection Head, Six Terminals, Flat Cover, Unpainted	Y	Y	Y	N			
T	Aluminum Connection Head, Six Terminals, Extended Cover, Unpainted	Y	Y	Y	N			
P	Aluminum Connection Head, Six Terminals, Flat Cover, Painted	Y	Y	Y	N			
L	Aluminum Connection Head, Six Terminals, Extended Cover, Painted	Y	Y	Y	N			
N	Sensor only with 6-in. PTFE-insulated, 22-gauge lead wires	Y	Y	Y	N			
G	Rosemount SST Connection Head with 1/2 in. Entries	Y	Y	Y	Y			
Code	Sensor Type	Temperature						
<b>Single Element Temperature Sensors</b>		<b>-200 to 500 °C (-328 to 932 °F)</b>						
01 <sup>(1)(2)</sup>	Capsule style							
11	General-purpose style							
21 <sup>(3)</sup>	Spring-loaded style							
31 <sup>(4)</sup>	Bayonet spring-loaded style (available in (X) lengths of 1 to 21-in, increments of 1-in.)							
<b>Single Element High Temperature Sensors</b>		<b>0 to 600 °C (32 to 1112 °F)</b>						
03 <sup>(1)</sup>	Capsule style (available in (X) lengths of 3 to 48-in, increments of 1-in.)							
13	General-purpose style (available in (X) lengths of 3 to 48-in, increments of 1/2-in.)							
23 <sup>(3)</sup>	Spring-loaded style (available in (X) lengths of 3 to 48-in, increments of 1/2-in.)							
33 <sup>(4)</sup>	Bayonet spring-loaded style (available in (X) lengths of 3 to 21-in, increments of 1-in.)							
<b>Dual-element Temperature Sensors</b>		<b>-200 to 500 °C (-328 to 932 °F)</b>						
05 <sup>(1)</sup>	Capsule style							
15	General-purpose style							
25 <sup>(3)</sup>	Spring-loaded style							
35 <sup>(4)</sup>	Bayonet spring-loaded style (available in (X) lengths of 1 to 21-in, increments of 1-in.)							
Code	Extension Type	Material						
A <sup>(5)</sup>	Nipple Coupling	SST						
C <sup>(5)</sup>	Nipple Union	SST						
N	None	(Use with extension length option code 00)						
Code	Extension Length (E)							
00	0.0 in.							
30	3.0 in. (X) sensor length = (E) extension length + (L) thermowell length minus 0.25 in. (see Figure 4.)							
60	6.0 in.							
Code	Thermowell Material							
N	No thermowell required							
Code	Immersion Length (L)		Code	Immersion Length (L)		Code	Immersion Length (L)	
010	1.0-in.		130	13.0-in.		250	25.0-in.	
015	1.5-in.		135	13.5-in.		260	26.0-in.	
020	2.0-in.		140	14.0-in.		270	27.0-in.	
025	2.5-in.		145	14.5-in.		280	28.0-in.	
030	3.0-in.		150	15.0-in.		290	29.0-in.	
035	3.5-in.		155	15.5-in.		300	30.0-in.	
040	4.0-in.		160	16.0-in.		310	31.0-in.	
045	4.5-in.		165	16.5-in.		320	32.0-in.	
050	5.0-in.		170	17.0-in.		330	33.0-in.	
055	5.5-in.		175	17.5-in.		340	34.0-in.	
060	6.0-in.		180	18.0-in.		350	35.0-in.	
065	6.5-in.		185	18.5-in.		360	36.0-in.	
070	7.0-in.		190	19.0-in.		370	37.0-in.	
075	7.5-in.		195	19.5-in.		380	38.0-in.	
080	8.0-in.		200	20.0-in.		390	39.0-in.	
085	8.5-in.		205	20.5-in.		400	40.0-in.	
090	9.0-in.		210	21.0-in.		410	41.0-in.	
095	9.5-in.		215	21.5-in.		420	42.0-in.	
100	10.0-in.		220	22.0-in.		430	43.0-in.	
105	10.5-in.		225	22.5-in.		440	44.0-in.	
110	11.0-in.		230	23.0-in.		450	45.0-in.	
115	11.5-in.		235	23.5-in.		460	46.0-in.	
120	12.0-in.		240	24.0-in.		470	47.0-in.	
125	12.5-in.		245	24.5-in.		480 <sup>(6)</sup>	48.0-in.	

Ordering Options Continued on Next Page

Code	Options
<b>Sensor</b>	
A <sup>(7)</sup>	IEC – 751 Class A Sensor
<b>Product Certifications</b>	
E5	FM Explosion-proof approval (See Figure 26)
E6	CSA Explosion-proof approval (See Figure 27)
E7 <sup>(8)</sup>	SAA Flameproof approval (See Figure 30)
E1 <sup>(9)</sup>	ATEX Flameproof approval (See Figure 29)
<b>Calibration</b>	
V1-V7	Choose from “option code “V”–Callendar-van Dusen Constants.” See Option Code “V” Callendar-van Dusen Constants. Option code V4 is only available for high temperature sensors.
X8Q4	Calibrate to customer-specified temperature range (See Option X8Q4: Sensor Calibrated to a Customer-Specified Temperature Range)
X9Q4	Calibrate to customer-specified single temperature point (See Option X9Q4: Sensor Calibrated to a Customer-Specified Single Point)
<b>Mounting Adapters, Lead Wire Extensions, Connectors, and Seals</b>	
M5-M7	Mounting adapters
A1-A8	Twisted lead wire extensions
B1-B8 <sup>(10)</sup>	Shielded cable lead wire extensions
C1-C8 <sup>(10)</sup>	Armored cable lead wire extensions
D1-D8 <sup>(10)</sup>	Armored cable lead wire extensions with electrical plugs
L1-L8	Armored cable mating plugs with lead wire extensions
F1 <sup>(10)</sup>	4-pin bayonet connector
H1-H8	4-pin connector mating plugs with lead wire extensions
J1	Moisture-proof seal assembly for armored cables
XA <sup>(11)</sup>	Assemble connection head or transmitter to a sensor assembly (PTFE paste where appropriate, fully wired.)

- (1) Capsule style available in 1-in. increments only. See “Mounting Adapters for Series 58, 68, 78, and 183” on page Temperature-52.
- (2) Must be used with Sensor Lead Wire Termination code N and is not available with assembly option XA or with approval option codes E1, E5, E6, or E7.
- (3) Spring loaded sensors must be installed in a thermowell assembly to meet the requirements of explosion-proof approval option code E6.
- (4) This option is not available with Sensor Lead Wire Termination codes R, P or C or approval code E1, E6, and E7.
- (5) Codes A and C must be used with an extension length. Additional non-standard (E) lengths are available in 1/2-in. increments from 2.5 to 9-in.
- (6) Additional lengths are available up to 68-in., increments of 1-in.
- (7) The IEC 751 Class A option is not available with high-temperature sensors.
- (8) SAA Flameproof approvals only applicable if installed with a Rosemount 248, 644, or 3144P transmitter.
- (9) ATEX Flameproof approvals only applicable if ordered with Sensor Lead Wire Terminator code D, R, T, P, or L (Rosemount connection head) or installed with Rosemount 248, 644, or 3144P transmitters.
- (10) Requires Sensor lead wire termination code N
- (11) If ordering option code XA with a transmitter, specify the same option on the transmitter model code.

TABLE 9. Ordering Example

Typical Model Number	Model	Lead Wire Termination	Sensor Type	Extension Type	Extension Length	Thermowell Material	Immersion Length	Additional Options
	0078	N	21	N	00	N	045	E5

# Sensors and Accessories (English)

TABLE 10. Series 78 RTD Sensor Assemblies WITH Thermowell

Model	Product Description	Available Safety Approvals									
0078	Platinum Wire-Wound Temperature Sensors and Sensor Assemblies										
Code	Sensor Lead Wire Termination	FM	ATEX	CSA	SAA						
D	Rosemount Aluminum Connection head	Y	Y	Y	Y						
C	Polypropylene Connection Head	N	N	N	N						
R	Aluminum Connection Head, Six Terminals, Flat Cover, Unpainted	Y	Y	Y	N						
T	Aluminum Connection Head, Six Terminals, Extended Cover, Unpainted	Y	Y	Y	N						
P	Aluminum Connection Head, Six Terminals, Flat Cover, Painted	Y	Y	Y	N						
L	Aluminum Connection Head, Six Terminals, Extended Cover, Painted	Y	Y	Y	N						
N	Sensor only with 6-in. PTFE-insulated, 22-gauge lead wires	Y	Y	Y	N						
G	Rosemount SST Connection Head with 1/2 in. Entries	Y	Y	Y	Y						
Code	Sensor Type	Temperature									
<b>Single Element Temperature Sensors</b>		<b>-200 to 500 °C (-328 to 932 °F)</b>									
11	General-purpose style										
21	Spring-loaded style										
31 <sup>(1)(2)</sup>	Bayonet spring-loaded style (available in (X) lengths of 1 to 21-in., increments of 1-in.)										
<b>Single Element High Temperature Sensors</b>		<b>0 to 600 °C (32 to 1112 °F)</b>									
13	General-purpose style (available in (X) lengths of 3 to 24-in., increments of 1/2-in.)										
23	Spring-loaded style (available in (X) lengths of 3 to 24-in., increments of 1/2-in.)										
33 <sup>(1)(2)</sup>	Bayonet spring-loaded style (available in (X) lengths of 3 to 21-in., increments of 1-in.)										
<b>Dual-element Temperature Sensors</b>		<b>-200 to 500 °C (-328 to 932 °F)</b>									
15	General-purpose style										
25	Spring-loaded style										
35 <sup>(1)(2)</sup>	Bayonet spring-loaded style (available in (X) lengths of 1 to 21-in., increments of 1-in.)										
Code	Extension Type	Material									
A <sup>(3)</sup>	Nipple Coupling	SST									
C <sup>(3)</sup>	Nipple Union	SST									
N	None	(Use with extension length option code 00)									
Code	Extension Length (E)										
00	0.0 in.										
30	3.0 in.	(X) sensor length = (E) extension length + (L) thermowell length minus 0.25 in. (see Figure 4.)									
60	6.0 in.										
Code	Thermowell Material	Code	Thermowell Material								
A	Type 316 SST <sup>(4)</sup>	J	Hastelloy® C (with 304 SST Flange, if flange style is ordered)								
B	Type 304 SST	L	Hastelloy B (with 304 SST Flange, if flange style is ordered)								
C	Carbon Steel	M	304 SST with PTFE coating								
D	316L SST	P	Chrome Molybdenum F22								
E	304L SST	R	Nickel 200								
F	Alloy 20	T	Titanium								
G	Monel®	U <sup>(5)</sup>	316 SST with Tantalum Sheath								
H	Inconel® 600	W	321 SST								
		Z	Chrome Molybdenum F11								
Code	Length			Code	Length			Code	Length		
	U <sup>(6)</sup>	L	T <sup>(7)</sup>		U <sup>(6)</sup>	L	T <sup>(7)</sup>		U <sup>(6)</sup>	L	T <sup>(7)</sup>
015 <sup>(8)</sup>	1.5-in.	4.0-in.	1.0-in.	130	13.0-in.	15.0-in.	0.5-in.	260	26.0-in.	30.0-in.	2.5-in.
020 <sup>(8)</sup>	2.0-in.	4.0-in.	0.5-in.	135	13.5-in.	15.0-in.	0.0-in.	270	27.0-in.	30.0-in.	1.5-in.
025 <sup>(8)</sup>	2.5-in.	4.0-in.	0.0-in.	140	14.0-in.	18.0-in.	2.5-in.	280	28.0-in.	30.0-in.	0.5-in.
030	3.0-in.	6.0-in.	1.5-in.	145	14.5-in.	18.0-in.	2.0-in.	290	29.0-in.	33.0-in.	2.5-in.
035	3.5-in.	6.0-in.	1.0-in.	150	15.0-in.	18.0-in.	1.5-in.	300	30.0-in.	33.0-in.	1.5-in.
040	4.0-in.	6.0-in.	0.5-in.	155	15.5-in.	18.0-in.	1.0-in.	310	31.0-in.	33.0-in.	0.5-in.
045	4.5-in.	6.0-in.	0.0-in.	160	16.0-in.	18.0-in.	0.5-in.	320	32.0-in.	36.0-in.	2.5-in.
050	5.0-in.	9.0-in.	2.5-in.	165	16.5-in.	18.0-in.	0.0-in.	330	33.0-in.	36.0-in.	1.5-in.
055	5.5-in.	9.0-in.	2.0-in.	170	17.0-in.	21.0-in.	2.5-in.	340	34.0-in.	36.0-in.	0.5-in.
060	6.0-in.	9.0-in.	1.5-in.	175	17.5-in.	21.0-in.	2.0-in.	350	35.0-in.	39.0-in.	2.5-in.
065	6.5-in.	9.0-in.	1.0-in.	180	18.0-in.	21.0-in.	1.5-in.	360	36.0-in.	39.0-in.	1.5-in.
070	7.0-in.	9.0-in.	0.5-in.	185	18.5-in.	21.0-in.	1.0-in.	370	37.0-in.	39.0-in.	0.5-in.
075	7.5-in.	9.0-in.	0.0-in.	190	19.0-in.	21.0-in.	0.5-in.	380	38.0-in.	42.0-in.	2.5-in.
080	8.0-in.	12.0-in.	2.5-in.	195	19.5-in.	21.0-in.	0.0-in.	390	39.0-in.	42.0-in.	1.5-in.
085	8.5-in.	12.0-in.	2.0-in.	200	20.0-in.	24.0-in.	2.5-in.	400	40.0-in.	42.0-in.	0.5-in.
090	9.0-in.	12.0-in.	1.5-in.	205	20.5-in.	24.0-in.	2.0-in.	410	41.0-in.	45.0-in.	2.5-in.
095	9.5-in.	12.0-in.	1.0-in.	210	21.0-in.	24.0-in.	1.5-in.	420	42.0-in.	45.0-in.	1.5-in.
100	10.0-in.	12.0-in.	0.5-in.	215	21.5-in.	24.0-in.	1.0-in.	430	43.0-in.	45.0-in.	0.5-in.
105	10.5-in.	12.0-in.	0.0-in.	220	22.0-in.	24.0-in.	0.5-in.	440	44.0-in.	48.0-in.	2.5-in.
110	11.0-in.	15.0-in.	2.5-in.	225	22.5-in.	24.0-in.	0.0-in.	450	45.0-in.	48.0-in.	1.5-in.
115	11.5-in.	15.0-in.	2.0-in.	230	23.0-in.	27.0-in.	2.5-in.	460	46.0-in.	48.0-in.	0.5-in.
120	12.0-in.	15.0-in.	1.5-in.	240	24.0-in.	27.0-in.	1.5-in.	470	47.0-in.	51.0-in.	2.5-in.
125	12.5-in.	15.0-in.	1.0-in.	250	25.0-in.	27.0-in.	0.5-in.	480	48.0-in.	51.0-in.	1.5-in.

Ordering Options Continued on Next Page

# Product Data Sheet

00813-0100-2654, Rev GA

March 2008

# Sensors and Accessories (English)

Code	Thermowell	Mounting	Stem	Tip A (in.)	Root B (in.)
T20 <sup>(4)</sup>	Threaded	1/2-14 ANPT	Stepped	0.50	0.63
T22 <sup>(4)</sup>	Threaded	3/4-14 ANPT	Stepped	0.50	0.75
T24 <sup>(4)</sup>	Threaded	1-11.5 ANPT	Stepped	0.50	0.88
T26	Threaded	3/4-14 ANPT	Tapered	0.63	0.88
T28	Threaded	1-11.5 ANPT	Tapered	0.63	1.06
T30	Threaded	1 1/2-11 ANPT	Tapered	0.75	1.50
T32	Threaded	1/2-14 ANPT	Straight	0.50	0.50
T34	Threaded	3/4-14 ANPT	Straight	0.75	0.75
T36	Threaded	1-11.5 ANPT	Straight	0.75	0.75
T38	Threaded	3/4-14 ANPT	Straight	0.50	0.50
T44	Threaded	1/2-14 ANPT	Tapered	0.50	0.63
W38	Welded	3/4-in. pipe	Stepped	0.50	0.75
W40	Welded	1-in. pipe	Stepped	0.50	0.88
W42	Welded	3/4-in. pipe	Tapered	0.63	0.88
W44	Welded	1-in. pipe	Tapered	0.75	1.00
W46	Welded	1 1/4-in. pipe	Tapered	0.75	1.25
W48	Welded	3/4-in. pipe	Straight	0.75	0.75
W50	Welded	1-in. pipe	Straight	0.75	0.75
F10	Flanged	2-in., Class 150	Straight	0.75	0.75
F12	Flanged	3-in., Class 150	Straight	0.75	0.75
F52	Flanged	1-in., Class 150	Stepped	0.50	0.75
F54	Flanged	1 1/2-in., Class 150	Stepped	0.50	0.75
F56	Flanged	2-in., Class 150	Stepped	0.50	0.75
F58	Flanged	1-in., Class 150	Tapered	0.75	1.00
F60	Flanged	1 1/2-in., Class 150	Tapered	0.75	1.00
F62	Flanged	2-in. Class 150	Tapered	0.75	1.25
F64	Flanged	1-in., Class 150	Straight	0.75	0.75
F66	Flanged	1 1/2-in., Class 150	Straight	0.75	0.75
F70	Flanged	1-in., Class 300	Stepped	0.50	0.75
F72	Flanged	1 1/2-in., Class 300	Stepped	0.50	0.75
F74	Flanged	2-in., Class 300	Stepped	0.50	0.75
F76	Flanged	1-in., Class 300	Tapered	0.75	1.00
F78	Flanged	1 1/2-in., Class 300	Tapered	0.75	1.00
F80	Flanged	2-in., Class 300	Tapered	0.75	1.25
F82	Flanged	1-in., Class 300	Straight	0.75	0.75
F84	Flanged	1 1/2-in., Class 300	Straight	0.75	0.75
F86	Flanged	2-in., Class 300	Straight	0.75	0.75
F88 <sup>(9)</sup>	Flanged	1-in., Class 600	Stepped	0.50	0.75
F90 <sup>(9)</sup>	Flanged	1 1/2-in., Class 600	Stepped	0.50	0.75
F92 <sup>(9)</sup>	Flanged	2-in., Class 600	Stepped	0.50	0.75
F94 <sup>(9)</sup>	Flanged	1-in., Class 600	Tapered	0.75	1.00
F96 <sup>(9)</sup>	Flanged	1 1/2-in., Class 600	Tapered	0.75	1.00
F98 <sup>(9)</sup>	Flanged	2-in., Class 600	Tapered	0.75	1.25
F02 <sup>(9)</sup>	Flanged	1-in., Class 600	Straight	0.75	0.75
F04 <sup>(9)</sup>	Flanged	1 1/2-in., Class 600	Straight	0.75	0.75
F06 <sup>(9)</sup>	Flanged	2-in., Class 600	Straight	0.75	0.75
F16 <sup>(9)</sup>	Flanged	1 1/2-in., Class 900	Tapered	0.75	1.00
F34 <sup>(9)</sup>	Flanged	1 1/2-in., Class 1500	Tapered	0.75	1.00
F24 <sup>(9)</sup>	Flanged	2-in., Class 1500	Tapered	0.75	1.25
F08 <sup>(9)</sup>	Flanged	1 1/2-in., Class 2500	Tapered	0.75	1.00
Q02 <sup>(10)</sup>	Sanitary, Tri-Clamp	1-in., Tri-Clamp	Stepped	0.50	0.75
Q04 <sup>(10)</sup>	Sanitary, Tri-Clamp	1 1/2-in., Tri-Clamp	Stepped	0.50	0.75
Q06 <sup>(10)</sup>	Sanitary, Tri-Clamp	2-in., Tri-Clamp	Stepped	0.50	0.75
Q08 <sup>(10)</sup>	Sanitary, Tri-Clamp	3-in., Tri-Clamp	Stepped	0.50	0.75
Q20 <sup>(10)</sup>	Sanitary, Tri-Clamp	3/4-in., Tri-Clamp	Straight	0.44	0.44
Q22 <sup>(10)</sup>	Sanitary, Tri-Clamp	1-in., Tri-Clamp	Straight	0.50	0.50
Q24 <sup>(10)</sup>	Sanitary, Tri-Clamp	1 1/2-in., Tri-Clamp	Straight	0.50	0.50
Q26 <sup>(10)</sup>	Sanitary, Tri-Clamp	2-in., Tri-Clamp	Straight	0.50	0.50
Q28 <sup>(10)</sup>	Sanitary, Tri-Clamp	3-in., Tri-Clamp	Straight	0.50	0.50

Code	Options
<b>Sensor</b>	
A <sup>(11)</sup>	IEC 751 Class A sensor
<b>Product Certifications</b>	
E5	FM Explosion-proof approval (See Figure 26)
E6	CSA Explosion-proof approval (See Figure 27)
E7 <sup>(12)</sup>	SAA Flameproof approval (See Figure 30)
E1 <sup>(13)</sup>	ATEX Flameproof approval (See Figure 29)

Ordering Options Continued on Next Page

# Sensors and Accessories (English)

Code	Options
<b>Calibration</b>	
V1-V7	Choose from "option code "V"-Callendar-van Dusen Constants." See Option Code "V" Callendar-van Dusen Constants. Option code V4 is only available with high temperature sensors.
X8Q4	Calibrate to customer-specified temperature range (See Option X8Q4: Sensor Calibrated to a Customer-Specified Temperature Range)
X9Q4	Calibrate to customer-specified single temperature point (See Option X9Q4: Sensor Calibrated to a Customer-Specified Single Point)
<b>Thermowell Options</b>	
Q8	Thermowell material certificate
R01	Thermowell special external pressure testing
R03	Thermowell dye penetration testing
R04	Special cleaning for oxygen service
R05	Thermowell NACE approval
R06	Stainless steel plug and chain
R07 <sup>(14)</sup>	Full penetration weld
R09 <sup>(14)(15)</sup>	Concentric serrations of thermowell flange face
R10 <sup>(14)(15)</sup>	Thermowell flat faced flange
R11	Thermowell vent hole (Not available with E6 approval)
R14	Thermowell special surface finish (12 R <sub>a</sub> Max) (Maximum (U) length = 22.5 in.)
R16 <sup>(14)(15)</sup>	Ring joint flange (Not available with 0-in. (T) length)
R20	Electropolishing
R21	Thermowell Wake Frequency Calculation (Configuration Data Sheet required)
R22	Internal pressure testing
R23	Brass plug and chain
R24	CRN Marking for British Columbia
R25	CRN Marking for Alberta
R26	CRN Marking for Saskatchewan
R27	CRN Marking for Manitoba
R28	CRN Marking for Ontario
R29	CRN Marking for Quebec
R30	CRN Marking for New Brunswick
R31	CRN Marking for Nova Scotia
R32	CRN Marking for Prince Edward Island
R33	CRN Marking for Yukon Territory
R34	CRN Marking for Northwest Territory
R35	CRN Marking for Nunavut
R36	CRN Marking for Newfoundland and Labrador
R37	Thermowell from Hex stock
<b>Mounting Adapters, Lead Wire Extensions, Connectors, and Seals</b>	
M5-M7	Mounting adapters
A1-A8	Twisted lead wire extensions
B1-B8 <sup>(16)</sup>	Shielded cable lead wire extensions
C1-C8 <sup>(16)</sup>	Armored cable lead wire extensions
D1-D8 <sup>(16)</sup>	Armored cable lead wire extensions with electrical plugs
L1-L8	Armored cable mating plugs with lead wire extensions
F1 <sup>(16)</sup>	4-pin bayonet connector
H1-H8	4-pin connector mating plugs with lead wire extensions
J1	Moisture-proof seal assembly for armored cables
XA <sup>(2)(17)</sup>	Assemble connection head or transmitter to a sensor assembly (PTFE paste where appropriate, fully wired.)

- (1) Not available with Sensor Lead Wire Termination codes R, P or W.
- (2) Not available with Approval codes E1, E6, or E7.
- (3) Codes A and C must be used with an extension length. Additional non-standard (E) lengths are available in 1/2-in. increments from 2.5 to 9-in.
- (4) Standard configuration with best delivery.
- (5) Available only with straight stem flanged thermowells.
- (6) Thermowells with an overall length ("U" + "T" + 1.75-in.) of 36-in. or less are machined from solid barstock. Thermowells with an overall length larger than 42-in. will be constructed using a welded 3-piece design and are available only with a stepped stem style.
- (7) For additional (T) lengths, see Table 28 on page Temperature-57.
- (8) Straight or Tapered stem only.
- (9) F88 to F08 cannot be used with 0-in. (T) length. F08 cannot be used with 0- or 1/2-in. (T) length
- (10) Limited to 24" immersion length and 316 or 304 SST materials only.
- (11) The IEC 751 Class A option is not available with high-temperature sensors.
- (12) SAA Flameproof approvals only applicable if installed with a Rosemount 248, 644, or 3144 transmitter.
- (13) ATEX Flameproof approvals only applicable if ordered with Sensor Lead Wire Terminator code D, R, T, P, or L (Rosemount connection head) or installed with Rosemount 248, 644, or 3144P transmitters.
- (14) Available on flanged thermowells only.
- (15) Only one flange face option allowed.
- (16) These options are not available with Sensor Lead Wire Termination codes R, P, or W.
- (17) If ordering option code XA with a transmitter, specify the same option on the transmitter model code.

TABLE 11. Ordering Example

Typical Model Number	Model	Lead Wire Termination	Sensor Type	Extension Type	Extension Length	Material Code	Immersion Length	Mounting Style	Additional Options
		0078	N	21	A	30	A	075	T22

## Product Data Sheet

00813-0100-2654, Rev GA

March 2008

# Sensors and Accessories (English)

## SERIES 68Q SANITARY PLATINUM RTD

Rosemount Series 68Q sanitary RTD temperature sensors measure from  $-50$  to  $200$  °C ( $-58$  to  $392$  °F). Series 68Q sensors are available in Tri-Clamp® endcap designs in immersion lengths from 1.0 to 9.5 inches. Table 12 shows the interchangeability of the Series 68Q sensor.

### Accuracy

TABLE 12. Series 68Q Interchangeability (IEC 751 Class B)

$\pm 0.55$ °C ( $\pm 0.99$ °F) at $-50$ °C ( $-58$ °F)
$\pm 0.30$ °C ( $\pm 0.54$ °F) at $0$ °C ( $32$ °F)
$\pm 0.80$ °C ( $\pm 1.44$ °F) at $100$ °C ( $212$ °F)
$\pm 1.30$ °C ( $\pm 2.34$ °F) at $200$ °C ( $392$ °F)

### Construction

Series 68Q sensors conform to 3-A Sanitary Standards and feature product contact surfaces designed for CIP cleaning. The response times of Series 68Q sensors meet the Grade A Pasteurized Milk Ordinance (PMO) specification for thermometric response of an indicating thermometer on a pipeline. Series 68Q sensors are offered in a Tri-Clamp sanitary endcap configuration. The sensor capsule is welded into the 316 SST sanitary endcap/stem assembly. The product contact of this assembly is polished to a finish that exceeds No. 4 minimum finish as required by the 3-A Sanitary Council Standard #74-02.

### Platinum Element and Lead Wire Configurations

Single-element temperature sensors have four lead wires and may be used in 2-, 3-, and 4-wire signal conditioning systems. Dual-element sensors have six lead wires and may be used in 2- and 3-wire signal conditioning systems.

## SPECIFICATIONS

### Performance

#### Temperature Range

$-50$  to  $200$  °C ( $-58$  to  $392$  °F)

#### Maximum Hysteresis

$\pm 0.09\%$  of operating temperature range

#### Stability

Tri-clamp O.D. Tube Size 1-in. and greater:

$\pm 0.04\%$  maximum ice-point resistance shift following 1,000 hours at maximum specified temperature  $392$  °F ( $200$  °C).

Tri-clamp O.D. Tube Size  $1/2$  -  $3/4$ -in.:

$\pm 0.08\%$  maximum ice-point resistance shift following 1,000 hours at maximum specified temperature  $392$  °F ( $200$  °C).

### Response Time

Tri-clamp O.D. Tube Size 1-in. and greater

Less than 3.5 seconds required to reach 63.2% sensor response in water flowing at 3 ft/s (0.91 m/s). Meets PMO specification

Tri-clamp O.D. Tube Size  $1/2$  -  $3/4$ -in.:

Less than 1.5 seconds required to reach 63.2% sensor response in water flowing at 3 ft/s (0.91 m/s).

### Insulation Resistance

$500 \times 10^6$  ohms minimum insulation resistance when measured at 100 V dc at room temperature

### Surface Finish

$32R_A$  standard finish on product contact surfaces. Meets 3-A requirements

$15R_A$  high mechanical polish available with option code HP.

## Environmental

### Humidity Limits

Lead seal is capable of withstanding 100% relative humidity

### Quality Assurance

Each sensor is subjected to a resistance accuracy test at  $0$  °C

### Physical Specifications

#### Sheath Material

316 SST

#### Lead Wire

PTFE-insulated, nickel-coated, 24-gauge stranded copper wire

#### Identification Data

The model and serial numbers and up to six lines of permanent tagging information are etched on each sensor. Stainless steel tags are available upon request

#### Weight

0.6 to 2.0 lb (0.3 to 0.9 kg)

# Sensors and Accessories (English)

## Dimensional Drawings

FIGURE 10. 68Q Sanitary Sensor and Polypropylene Connection Head Dimensional Drawings

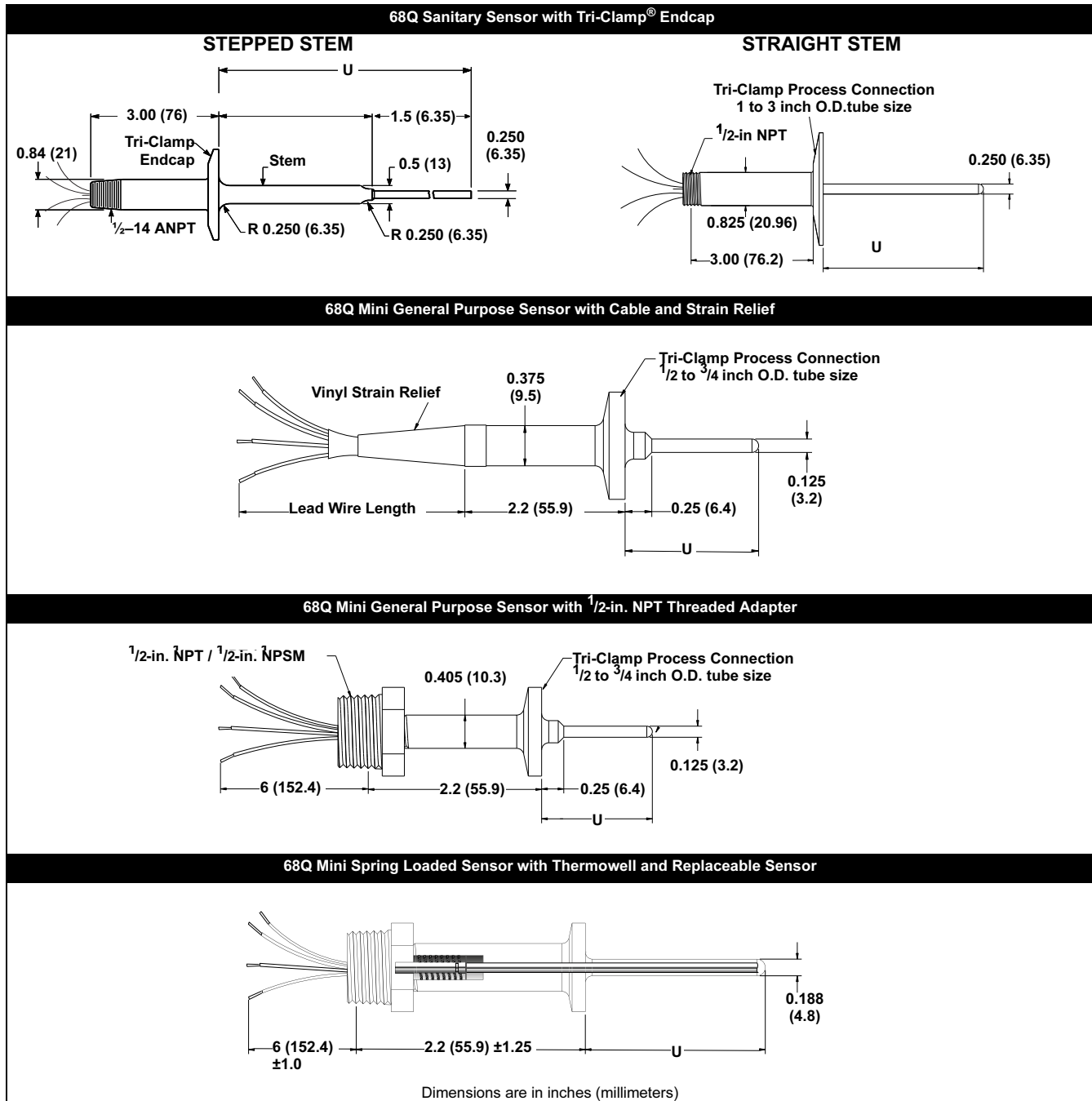

TABLE 13. Series 68Q Spare Parts List

Mini Spring-Loaded Sanitary Replacement Sensors and Thermowells			
Immersion Length (U)	Replacement Sensor Part Number	Replacement Thermowell Part Number	
2.0	00068-4035-0020	00068-4035-1020	
2.5	00068-4035-0025	00068-4035-1025	
3.0	00068-4035-0030	00068-4035-1030	

TABLE 14. Series 68Q Sanitary Platinum RTD Sensor Assemblies

Model	Product Description				
0068Q	Series 68Q Sanitary RTD Temperature Sensors				
Code	Sensor Lead Wire Termination				
D	Rosemount Aluminum Connection Head				
C	Polypropylene Connection Head, Six Terminals				
P	Aluminum Connection Head, Six Terminals, Flat Cover, Painted				
L	Aluminum Connection Head, Six Terminals, Extended Cover, Painted				
N	Sensor only, 24-gauge lead wires				
Code	Sensor Type	Temperature			
11	Single Stepped Stem	-50 to 200 °C (-58 to 392 °F)			
15	Dual Stepped Stem	-50 to 200 °C (-58 to 392 °F)			
21	Single Straight Stem	-50 to 200 °C (-58 to 392 °F)			
25	Dual Straight Stem	-50 to 200 °C (-58 to 392 °F)			
30 <sup>(1)</sup> (2)	Mini General Purpose 6-in. lead with <sup>1</sup> / <sub>2</sub> -in. NPT Threaded Adapter	-50 to 200 °C (-58 to 392 °F)			
31 <sup>(1)</sup> (2)(3)	Mini General Purpose 6-in. lead with <sup>1</sup> / <sub>2</sub> -in. NPSM Threaded Adapter	-50 to 200 °C (-58 to 392 °F)			
32 <sup>(1)</sup> (2)(3)	Mini General Purpose 180-in. cable with strain relief	-50 to 200 °C (-58 to 392 °F)			
33 <sup>(1)</sup> (2)(3)	Mini General Purpose 300-in. cable with strain relief	-50 to 200 °C (-58 to 392 °F)			
41 <sup>(4)</sup>	Mini Spring Loaded with thermowell replacement sensor	-50 to 200 °C (-58 to 392 °F)			
Code	Sensor Immersion Length (L) (in.)	Code	Sensor Immersion Length (L) (in.)	Code	Sensor Immersion Length (L) (in.)
U010	1.00	U019	1.90	U060	6.00
U011	1.10	U020	2.00	U065	6.50
U012	1.20	U025	2.50	U070	7.00
U013	1.25	U030	3.00	U075	7.50
U014	1.40	U035	3.50	U080	8.00
U015	1.50	U040 <sup>(5)</sup>	4.00	U085	8.50
U016	1.60	U045	4.50	U090	9.00
U017	1.70	U050 <sup>(5)</sup>	5.00	U095	9.50
U018	1.80	U055	5.50		
Code	Endcap Type	O.D. Tube Size (inches)			
L050 <sup>(6)</sup>	Tri-Clamp	<sup>1</sup> / <sub>2</sub> to <sup>3</sup> / <sub>4</sub>			
L100	Tri-Clamp	1.00			
L150 <sup>(5)</sup>	Tri-Clamp	1.50			
L200 <sup>(5)</sup>	Tri-Clamp	2.00			
L250	Tri-Clamp	2.50			
L300	Tri-Clamp	3.00			
Code	Additional Options				
<b>Calibration Options</b>					
V1-V7	"V"—Callendar-van Dusen Constants. Option codes V3, V4, and V7 are not available with Series 68Q sensors.				
X8Q4	Calibrate to customer-specified temperature range (See Option X8Q4: Sensor Calibrated to a Customer-Specified Temperature Range)				
X9Q4	Calibrate to customer-specified single temperature point (See Option X9Q4: Sensor Calibrated to a Customer-Specified Single Point)				
<b>Additional Options</b>					
R20 <sup>(7)</sup>	Electropolishing of wetted surfaces				
XA <sup>(8)</sup>	Assemble connection head or transmitter to a sensor assembly (PTFE paste where appropriate, fully wired.)				
HP	High Mechanical Polish, 15R <sub>a</sub> or better				
Q8	Material Certification				
(1) Only available in immersion lengths between 1-in. and 2-in.					
(2) Only available with Tri-Clamp O.D. tube size <sup>1</sup> / <sub>2</sub> to <sup>3</sup> / <sub>4</sub> -in. (Endcap type code L050).					
(3) Only available with Sensor lead Wire Termination code N (sensor only).					
(4) Only available in U lengths of 2.0, 2.5, or 3.0 inches.					
(5) Standard configuration with best delivery.					
(6) Only available in sensor type code 30, 31, 32, 33					
(7) If ordering a Mini General Purpose or Mini Spring Loaded Sensor (Sensor Type codes 30, 31, 32, 33, or 41) with Electropolishing, High Mechanical Polish (Option code HP) is also required.					
(8) If ordering option code XA with a transmitter, specify the same option on the transmitter model code.					

**Ordering Example**

Typical Model Number	Model	Lead Wire Termination	Sensor Type	Immersion Length	Endcap Type, Tube Size	Additional Options
	0068Q	N	11	U050	L150	V2

# Sensors and Accessories (English)

## SERIES 58C PLATINUM RTD

Rosemount Series 58C sensors are available in 12-, 24-, 36-, and 48-inch (X) lengths and may be shortened to any desired length with an ordinary tubing cutter. This cut-to-fit feature eliminates the need to stock a large selection of sensors in many specific lengths. Table 15 shows the interchangeability of the Series 58C Sensor.

TABLE 15. Series 58C Interchangeability (IEC 751 Class B)

$\pm 0.55$ °C ( $\pm 0.99$ °F) at $-50$ °C ( $-58$ °F)
$\pm 0.30$ °C ( $\pm 0.54$ °F) at $0$ °C ( $32$ °F)
$\pm 0.80$ °C ( $\pm 1.44$ °F) at $100$ °C ( $212$ °F)
$\pm 1.30$ °C ( $\pm 2.34$ °F) at $200$ °C ( $392$ °F)

## Specifications

### Performance Specifications

#### Temperature Range

$-50$  to  $200$  °C ( $-58$  to  $392$  °F)

#### Maximum Hysteresis

$\pm 0.09\%$  of operating temperature range.

### Stability

$\pm 0.035\%$  maximum ice-point resistance shift following 1,000 hours at maximum specified temperature ( $200$  °C).

### Insulation Resistance

$500 \times 10^6$  ohms minimum insulation resistance when measured at  $50$  V dc at room temperature.

### Environmental Specifications

#### Humidity Limits

No permanent rear seal is installed

#### Quality Assurance

Each sensor is subjected to a resistance accuracy test at  $0$  °C and an insulation resistance test

### Physical Specifications

#### Sheath Material

316 SST

#### Lead Wires

PTFE-insulated, nickel-coated, 24-gauge stranded copper wire

## Dimensional Drawings

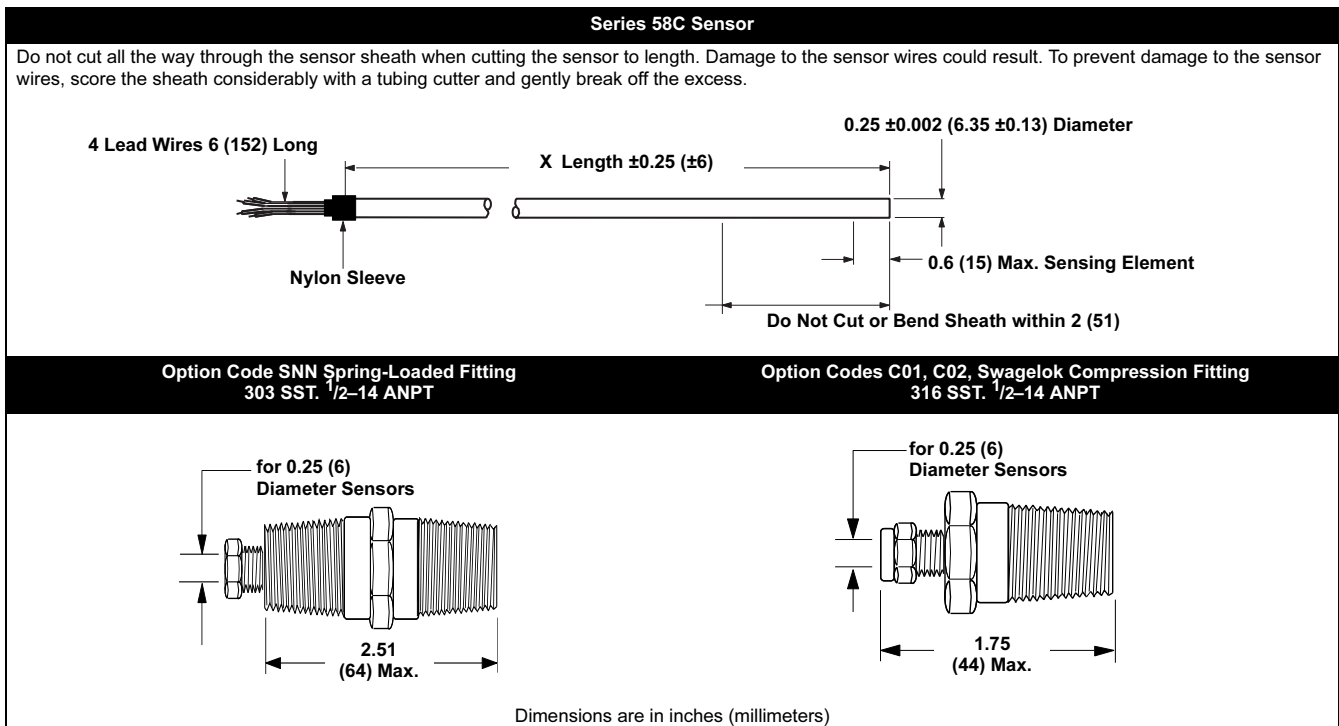

**Ordering Information**

TABLE 16. Series 58C Cut-to-Fit RTD Sensors

Model	Product Description
0058C	Platinum Resistance Temperature Sensor (-50 to 200 °C (-58 to 392 °F))
Code	Sensor Lead Wire Termination
D	Rosemount Aluminum Connection Head
C	Polypropylene Connection Head
R	Aluminum Connection Head, Six Terminals, Flat Cover, Unpainted
T	Aluminum Connection Head, Six Terminals, Extended Cover, Unpainted
P	Aluminum Connection Head, Six Terminals, Flat Cover, Painted
L	Aluminum Connection Head, Six Terminals, Extended Cover, Painted
N	Sensor only with 6-in. PTFE-insulated, 22-gauge lead wires
Code	Sensor Length (X) in inches
1200	12
2400	24
3600	36
4800	48
Code	Mounting Adapter
NNN	None
C01 <sup>(1)</sup>	One-compression fitting 1/2-14 ANPT
C02 <sup>(1)</sup>	Two-compression fittings 1/2-14 ANPT
SNN	Spring-loaded fitting 1/2-14 ANPT

(1) The only difference between C01 and C02 is that the C01 includes one fitting while the C02 option includes two fittings.

**Ordering Example**

Typical Model Number	Model	Lead Wire Termination	Sensor Length	Mounting Adapter
	0058C	R	1200	SNN

TABLE 17. Series 58C Spare Parts List

(specify spare part number separately when ordering mounting adapters)

Mounting Adapters	Option Code	Spare Part Number
Compression fitting 1/2-14 ANPT	C01 and C02	C07961-0008
Spring loaded fitting 1/2-14 ANPT	SNN	00058-0010-0001

# Sensors and Accessories (English)

## SERIES 183 THERMOCOUPLE

Rosemount Series 183 Thermocouple sensors measure from -180 to 1150 °C (-292 to 2102 °F).

### Construction

The Series 183 Thermocouples are manufactured using ISA Type J, K, E, or T wire with "special limits of error" accuracy. The junction of these wires is fusion-welded to form a pure joint, to maintain the integrity of the circuit, and to ensure the highest accuracy. Grounded junctions are available for improved response time and good thermal contact with protection from the environment. The ungrounded and isolated junctions provide electrical isolation from the sensor sheath (see Figure 11).

Rosemount thermocouples are encased in a protective metal sheath. The sheath material is 304 SST for types J, E, and T, used at temperatures up to 871 °C and Inconel for type K, used at temperatures up to 1150 °C. Metallic oxide insulation is compacted into the sheath to mechanically support and electrically insulate the thermocouple wire. See Table 22 for more information on the different types of thermocouples.

FIGURE 11. Series 183 Junction Configurations

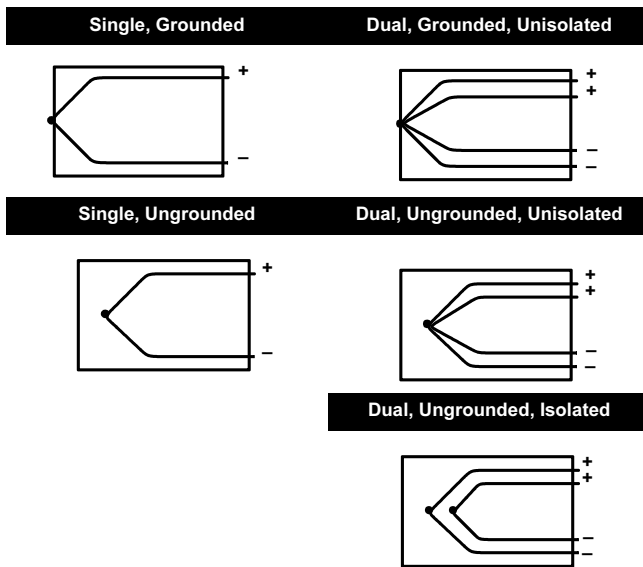
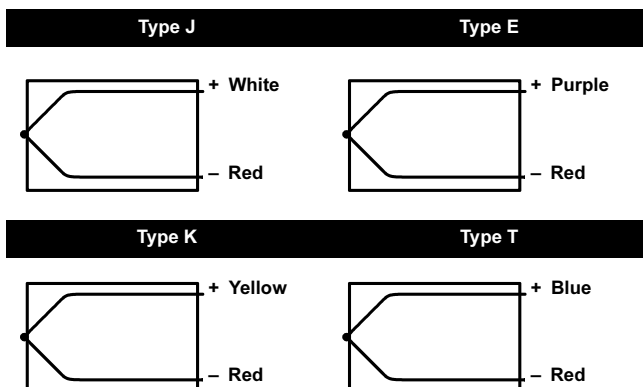

FIGURE 12. Series 183 Lead Wire Configurations



## Specifications

### Performance Specifications

The thermoelectric current relationship in a thermocouple is standardized and defined by ASTM E-230. All Series 183 Thermocouples conform to these standards with "special limits of error" accuracy. The particular characteristics of each ISA type thermocouple are outlined in Table 22.

### Physical

#### Sheath Material

304 SST for types J, E, and T (used at temperatures up to 871 °C). Inconel for type K (used at temperatures up to 1150 °C).

#### Lead Wires

Thermocouple, internal—16 AWG solid wire (max), 18 AWG solid wire (min.). External lead wires—20 AWG wire, PTFE-insulated. Color coded per lead wire configuration schematic shown in Figure 12.

#### Identification Data

The model and serial numbers and up to six lines of permanent tagging information are etched on each sensor. Stainless steel tags are available upon request.

#### Weight

Capsule sensors: 5 ounces. General-purpose and spring-loaded sensors: 9 ounces.

#### Insulation Resistance

$100 \times 10^6$  ohms minimum insulation resistance when measured at 100 V dc at room temperature.

#### Enclosure Ratings

When installed properly, Rosemount Series 183 sensors are suitable for indoor and outdoor NEMA 4X and CSA Enclosure Type 4X installations. See Hazardous Area Approvals for complete installation information.

**Ordering Information**

TABLE 18. Series 183 Thermocouple Sensor Assemblies WITHOUT Thermowell

Model	Product Description	Available Safety Approvals			
0183	Thermocouple Temperature Sensors and Sensor Assemblies				
Code	Sensor Lead Wire Termination	FM	ATEX	CSA	SAA
D	Rosemount Aluminum Connection Head	Y	Y	Y	Y
C	Polypropylene Connection Head	N	N	N	N
R	Aluminum Connection Head, Six Terminals, Flat Cover, Unpainted	Y	Y	Y	N
T	Aluminum Connection Head, Six Terminals, Extended Cover, Unpainted	Y	Y	Y	N
P	Aluminum Connection Head, Six Terminals, Flat Cover, Painted	Y	Y	Y	N
L	Aluminum Connection Head, Six Terminals, Extended Cover, Painted	Y	Y	Y	N
N	Sensor only with 6-in. PTFE-insulated, 20-gauge lead wires (12-in. lead wires for dual thermocouples)	Y	Y	Y	N
Code	Sensor Type	Junction			
<b>Capsule Sensor<sup>(1)(2)</sup></b>					
01 <sup>(1)</sup>	Single	Grounded			
02	Dual	Grounded			
03	Single	Ungrounded			
04	Dual, Unisolated	Ungrounded			
05	Dual, Isolated	Ungrounded			
<b>General Purpose Sensors</b>					
11	Single	Grounded			
12	Dual	Grounded			
13	Single	Ungrounded			
14	Dual, Unisolated	Ungrounded			
15	Dual, Isolated	Ungrounded			
<b>Spring-Loaded Sensors<sup>(3)</sup></b>					
21	Single	Grounded			
22	Dual	Grounded			
23	Single	Ungrounded			
24	Dual, Unisolated	Ungrounded			
25	Dual, Isolated	Ungrounded			
<b>Bayonet Spring-Loaded Sensors<sup>(4)(5)</sup></b>					
31	Single	Grounded			
32	Dual	Grounded			
33	Single	Ungrounded			
34	Dual, Unisolated	Ungrounded			
35	Dual, Isolated	Ungrounded			
Code	Thermocouple Type	Temperature Range			
J2	J	0 to 760 °C (32 to 1400 °F)			
K2	K	0 to 1150 °C (32 to 2102 °F)			
E2	E	0 to 871 °C (32 to 1600°F)			
T2	T	-180 to 371 °C (-292 to 700 °F)			
Code	Extension Type	Material			
A <sup>(6)</sup>	Nipple Coupling	SST			
C <sup>(6)</sup>	Nipple Union	SST			
N	None	(Use with extension length option code 00)			
Code	Extension Length (E)				
00	0.0 in.				
30	3.0 in. (X) sensor length = (E) extension length + (L) thermowell length minus 0.25 in. (see Figure 4.)				
60	6.0 in.				
Code	Thermowell Material				
N	No thermowell required				

Ordering Options Continued on Next Page

# Sensors and Accessories (English)

Code	Sensor Immersion Length (L)	Code	Sensor Immersion Length (L)	Code	Sensor Immersion Length (L)
020	2.0-in.	140	14.0-in.	260	26.0-in.
025	2.5-in.	145	14.5-in.	270	27.0-in.
030	3.0-in.	150	15.0-in.	280	28.0-in.
035	3.5-in.	155	15.5-in.	290	29.0-in.
040	4.0-in.	160	16.0-in.	300	30.0-in.
045	4.5-in.	165	16.5-in.	310	31.0-in.
050	5.0-in.	170	17.0-in.	320	32.0-in.
055	5.5-in.	175	17.5-in.	330	33.0-in.
060	6.0-in.	180	18.0-in.	340	34.0-in.
065	6.5-in.	185	18.5-in.	350	35.0-in.
070	7.0-in.	190	19.0-in.	360	36.0-in.
075	7.5-in.	195	19.5-in.	370	37.0-in.
080	8.0-in.	200	20.0-in.	380	38.0-in.
085	8.5-in.	205	20.5-in.	390	39.0-in.
090	9.0-in.	210	21.0-in.	400	40.0-in.
095	9.5-in.	215	21.5-in.	410	41.0-in.
100	10.0-in.	220	22.0-in.	420	42.0-in.
105	10.5-in.	225	22.5-in.	430	43.0-in.
110	11.0-in.	230	23.0-in.	440	44.0-in.
115	11.5-in.	235	23.5-in.	450	45.0-in.
120	12.0-in.	240	24.0-in.	460	46.0-in.
125	12.5-in.	245	24.5-in.	470	47.0-in.
130	13.0-in.	250	25.0-in.	480	48.0-in.
135	13.5-in.				

Code	Options
<b>Product Certifications</b>	
E5	FM Explosion-proof approval (See Figure 26)
E6	CSA Explosion-proof approval (See Figure 27)
E7 <sup>(7)</sup>	SAA Flameproof approval (See Figure 30)
E1 <sup>(8)</sup>	ATEX Flameproof approval (See Figure 29)
<b>Mounting Adapters, Lead Wire Extensions, Connectors, and Seals</b>	
M5-M7	Mounting adapters
<b>Assembly Options</b>	
XA <sup>(9)</sup>	Assemble connection head or transmitter to a sensor assembly (hand tight, PTFE) paste where appropriate, fully wired.)
(1)	<i>This option must be used with Sensor Lead Wire Termination code N and is not available with assembly options XA.</i>
(2)	<i>Cannot be used with approval option codes E1, E5, E6, or E7. See "Mounting Adapters for Series 58, 68, 78, and 183" on page Temperature-52.</i>
(3)	<i>Spring-loaded sensors must be installed in a thermowell assembly to meet the requirement option code E6.</i>
(4)	<i>This option is not available with explosion-proof approval option code E6.</i>
(5)	<i>Bayonet spring-loaded style is available to 45-inches but is not available with Sensor Lead Wire Termination codes R, P, or W.</i>
(6)	<i>Codes A and C must be used with an extension length. Additional non-standard (E) lengths are available in 1/2-in. increments from 2.5 to 9-in.</i>
(7)	<i>SAA Flameproof approvals only applicable if installed with a Rosemount 248, 644, or 3144 transmitter.</i>
(8)	<i>ATEX Flameproof approval is only applicable if ordered with Sensor Lead Wire Terminator code D, R, P, T, or L (Rosemount connection head) or installed with Rosemount 248, 644, or 3144P transmitters.</i>
(9)	<i>If ordering option code XA with a transmitter, specify the same option on the transmitter model code.</i>

TABLE 19. Ordering Example

Typical Model Number	Model	Lead Wire Termination	Sensor Type	ISA Type	Extension Type	Extension Length	Thermowell Code	Immersion Length	Additional Options
		0183	N	11	J2	N	00	N	045

**Product Data Sheet**

00813-0100-2654, Rev GA

March 2008

**Sensors and Accessories (English)**

TABLE 20. Series 183 Thermocouple Sensor Assemblies WITH Thermowell

Model	Product Description	Available Safety Approvals									
0183	Thermocouple Temperature Sensors and Sensor Assemblies	FM	ATEX	CSA	SAA						
Code	Sensor Lead Wire Termination										
D	Rosemount Aluminum Connection Head	Y	Y	Y	Y						
C	Polypropylene Connection Head	N	N	N	N						
R	Aluminum Connection Head, Six Terminals, Flat Cover, Unpainted	Y	Y	Y	N						
T	Aluminum Connection Head, Six Terminals, Extended Cover, Unpainted	Y	Y	Y	N						
P	Aluminum Connection Head, Six Terminals, Flat Cover, Painted	Y	Y	Y	N						
L	Aluminum Connection Head, Six Terminals, Extended Cover, Painted	Y	Y	Y	N						
N	Sensor only with 6-in. PTFE-insulated, 20-gauge lead wires	Y	Y	Y	N						
Code	Sensor Type	Junction									
<b>General-Purpose Sensors</b>											
11	Single	Grounded									
12	Dual	Grounded									
13	Single	Ungrounded									
14	Dual, Unisolated	Ungrounded									
15	Dual, Isolated	Ungrounded									
<b>Spring-Loaded Sensors</b>											
21	Single	Grounded									
22	Dual	Grounded									
23	Single	Ungrounded									
24	Dual, Unisolated	Ungrounded									
25	Dual, Isolated	Ungrounded									
<b>Bayonet Spring-Loaded Sensors<sup>(1)(2)</sup></b>											
31	Single	Grounded									
32	Dual	Grounded									
33	Single	Ungrounded									
34	Dual, Unisolated	Ungrounded									
35	Dual, Isolated	Ungrounded									
Code	Thermocouple Type	Temperature Range									
J2	J	0 to 760 °C (32 to 1400 °F)									
K2	K	0 to 1150 °C (32 to 2102 °F)									
E2	E	0 to 871 °C (32 to 1600°F)									
T2	T	-180 to 371 °C (-292 to 700 °F)									
Code	Extension Type	Material									
A <sup>(3)</sup>	Nipple Coupling	SST									
C <sup>(3)</sup>	Nipple Union	SST									
N	None	(Use with extension length option code 00)									
Code	Extension Length (E)										
00	0.0 in.										
30	3.0 in.										
60	6.0 in.										
Code	Thermowell Material			Code	Thermowell Material						
A	Type 316 SST <sup>(4)</sup>			J	Hastelloy® C (with 304 SST Flange, if flange style is ordered)						
B	Type 304 SST			L	Hastelloy B (with 304 SST Flange, if flange style is ordered)						
C	Carbon Steel			M	304 SST with PTFE coating						
D	316L SST			P	Chrome Molybdenum F22						
E	304L SST			R	Nickel 200						
F	Alloy 20			T	Titanium						
G	Monel®			U <sup>(5)</sup>	316 SST with Tantalum Sheath						
H	Inconel® 600			W	321 SST						
				Z	Chrome Molybdenum F11						
Code	Length			Code	Length			Code	Length		
	U <sup>(6)</sup>	L	T <sup>(7)</sup>		U <sup>(9)</sup>	L	T <sup>(10)</sup>		U <sup>(9)</sup>	L	T <sup>(10)</sup>
015 <sup>(8)</sup>	1.5-in.	4.0-in.	1.0-in.	090	9.0-in.	12.0-in.	1.5-in.	165	16.5-in.	18.0-in.	0.0-in.
020 <sup>(8)</sup>	2.0-in.	4.0-in.	0.5-in.	095	9.5-in.	12.0-in.	1.0-in.	170	17.0-in.	21.0-in.	2.5-in.
025 <sup>(8)</sup>	2.5-in.	4.0-in.	0.0-in.	100	10.0-in.	12.0-in.	0.5-in.	175	17.5-in.	21.0-in.	2.0-in.
030	3.0-in.	6.0-in.	1.5-in.	105	10.5-in.	12.0-in.	0.0-in.	180	18.0-in.	21.0-in.	1.5-in.
035	3.5-in.	6.0-in.	1.0-in.	110	11.0-in.	15.0-in.	2.5-in.	160	16.0-in.	18.0-in.	0.5-in.
040	4.0-in.	6.0-in.	0.5-in.	115	11.5-in.	15.0-in.	2.0-in.	185	18.5-in.	21.0-in.	1.0-in.
045	4.5-in.	6.0-in.	0.0-in.	120	12.0-in.	15.0-in.	1.5-in.	190	19.0-in.	21.0-in.	0.5-in.
050	5.0-in.	9.0-in.	2.5-in.	125	12.5-in.	15.0-in.	1.0-in.	195	19.5-in.	21.0-in.	0.0-in.

Ordering Options Continued on Next Page

# Sensors and Accessories (English)

Code				Code				Code			
Length		Length		Length		Length		Length		Length	
U <sup>(9)</sup>	L	T <sup>(10)</sup>	U <sup>(9)</sup>	L	T <sup>(10)</sup>	U <sup>(9)</sup>	L	T <sup>(10)</sup>	U <sup>(9)</sup>	L	T <sup>(10)</sup>
055	5.5-in.	9.0-in.	2.0-in.	130	13.0-in.	15.0-in.	0.5-in.	200	20.0-in.	24.0-in.	2.5-in.
060	6.0-in.	9.0-in.	1.5-in.	135	13.5-in.	15.0-in.	0.0-in.	205	20.5-in.	24.0-in.	2.0-in.
065	6.5-in.	9.0-in.	1.0-in.	140	14.0-in.	18.0-in.	2.5-in.	210	21.0-in.	24.0-in.	1.5-in.
070	7.0-in.	9.0-in.	0.5-in.	145	14.5-in.	18.0-in.	2.0-in.	215	21.5-in.	24.0-in.	1.0-in.
075	7.5-in.	9.0-in.	0.0-in.	150	15.0-in.	18.0-in.	1.5-in.	220	22.0-in.	24.0-in.	0.5-in.
080	8.0-in.	12.0-in.	2.5-in.	155	15.5-in.	18.0-in.	1.0-in.	225	22.5-in.	24.0-in.	0.0-in.
085	8.5-in.	12.0-in.	2.0-in.								

Code	Thermowell	Mounting	Stem	Tip A (in.)	Root B (in.)
T20 <sup>(4)</sup>	Threaded	1/2-14 ANPT	Stepped	0.50	0.63
T22 <sup>(4)</sup>	Threaded	3/4-14 ANPT	Stepped	0.50	0.75
T24 <sup>(4)</sup>	Threaded	1-11.5 ANPT	Stepped	0.50	0.88
T26	Threaded	3/4-14 ANPT	Tapered	0.63	0.88
T28	Threaded	1-11.5 ANPT	Tapered	0.63	1.06
T30	Threaded	1 1/2-11 ANPT	Tapered	0.75	1.50
T32	Threaded	1/2-14 ANPT	Straight	0.50	0.50
T34	Threaded	3/4-14 ANPT	Straight	0.75	0.75
T36	Threaded	1-11.5 ANPT	Straight	0.75	0.75
T38	Threaded	3/4-14 ANPT	Straight	0.50	0.50
T44	Threaded	1/2-14 ANPT	Tapered	0.50	0.63
W38	Welded	3/4-in. pipe	Stepped	0.50	0.75
W40	Welded	1-in. pipe	Stepped	0.50	0.88
W42	Welded	3/4-in. pipe	Tapered	0.63	0.88
W44	Welded	1-in. pipe	Tapered	0.75	1.00
W46	Welded	1 1/4-in. pipe	Tapered	0.75	1.25
W48	Welded	3/4-in. pipe	Straight	0.75	0.75
W50	Welded	1-in. pipe	Straight	0.75	0.75
F10	Flanged	2-in., Class 150	Straight	0.75	0.75
F12	Flanged	3-in., Class 150	Straight	0.75	0.75
F52	Flanged	1-in., Class 150	Stepped	0.63	0.75
F54	Flanged	1 1/2-in., Class 150	Stepped	0.50	0.75
F56	Flanged	2-in., Class 150	Stepped	0.50	0.75
F58	Flanged	1-in., Class 150	Tapered	0.75	1.00
F60	Flanged	1 1/2-in., Class 150	Tapered	0.75	1.00
F62	Flanged	2-in. Class 150	Tapered	0.75	1.25
F64	Flanged	1-in., Class 150	Straight	0.75	0.75
F66	Flanged	1 1/2-in., Class 150	Straight	0.75	0.75
F70	Flanged	1-in., Class 300	Stepped	0.50	0.75
F72	Flanged	1 1/2-in., Class 300	Stepped	0.50	0.75
F74	Flanged	2-in., Class 300	Stepped	0.50	0.75
F76	Flanged	1-in., Class 300	Tapered	0.75	1.00
F78	Flanged	1 1/2-in., Class 300	Tapered	0.75	1.00
F80	Flanged	2-in., Class 300	Tapered	0.75	1.25
F82	Flanged	1-in., Class 300	Straight	0.75	0.75
F84	Flanged	1 1/2-in., Class 300	Straight	0.75	0.75
F86	Flanged	2-in., Class 300	Straight	0.75	0.75
F88 <sup>(11)</sup>	Flanged	1-in., Class 600	Stepped	0.50	0.75
F90 <sup>(11)</sup>	Flanged	1 1/2-in., Class 600	Stepped	0.50	0.75
F92 <sup>(11)</sup>	Flanged	2-in., Class 600	Stepped	0.50	0.75
F94 <sup>(11)</sup>	Flanged	1-in., Class 600	Tapered	0.75	1.00
F96 <sup>(11)</sup>	Flanged	1 1/2-in., Class 600	Tapered	0.75	1.00
F98 <sup>(11)</sup>	Flanged	2-in., Class 600	Tapered	0.75	1.25
F02 <sup>(11)</sup>	Flanged	1-in., Class 600	Straight	0.75	0.75
F04 <sup>(11)</sup>	Flanged	1 1/2-in., Class 600	Straight	0.75	0.75
F06 <sup>(11)</sup>	Flanged	2-in., Class 600	Straight	0.75	0.75
F16 <sup>(11)</sup>	Flanged	1 1/2-in., Class 900	Tapered	0.75	1.00
Code	Thermowell	Mounting	Stem	Tip A (in.)	Root B (in.)
F34 <sup>(11)</sup>	Flanged	1 1/2-in., Class 1500	Tapered	0.75	1.00
F24 <sup>(11)</sup>	Flanged	2-in., Class 1500	Tapered	0.75	1.25
F08 <sup>(11)</sup>	Flanged	1 1/2-in., Class 2500	Tapered	0.75	1.00
Q02 <sup>(12)</sup>	Sanitary, Tri-Clamp	1-in., Tri-Clamp	Stepped	0.50	0.75
Q04c	Sanitary, Tri-Clamp	1 1/2-in., Tri-Clamp	Stepped	0.50	0.75
Q06 <sup>(11)</sup>	Sanitary, Tri-Clamp	2-in., Tri-Clamp	Stepped	0.50	0.75
Q08 <sup>(11)</sup>	Sanitary, Tri-Clamp	3-in., Tri-Clamp	Stepped	0.50	0.75
Q20 <sup>(11)</sup>	Sanitary, Tri-Clamp	3/4-in., Tri-Clamp	Straight	0.44	0.44
Q22 <sup>(11)</sup>	Sanitary, Tri-Clamp	1-in., Tri-Clamp	Straight	0.50	0.50

Ordering Options Continued on Next Page

# Product Data Sheet

00813-0100-2654, Rev GA

March 2008

# Sensors and Accessories (English)

Code	Thermowell	Mounting	Stem	Tip A (in.)	Root B (in.)
Q24 <sup>(11)</sup>	Sanitary, Tri-Clamp	1 1/2-in., Tri-Clamp	Straight	0.50	0.50
Q26 <sup>(11)</sup>	Sanitary, Tri-Clamp	2-in., Tri-Clamp	Straight	0.50	0.50
Q28 <sup>(11)</sup>	Sanitary, Tri-Clamp	3-in., Tri-Clamp	Straight	0.50	0.50

Code	Options
------	---------

### Product Certifications

E5	FM Explosion-proof approval (See Figure 26)
E6	CSA Explosion-proof approval (See Figure 27)
E7 <sup>(13)</sup>	SAA Flameproof approval (See Figure 30)
E1 <sup>(14)</sup>	ATEX Flameproof approval (See Figure 29)

### Thermowell Options

Q8	Thermowell material certificate
R01	External pressure test
R03	Thermowell dye penetration testing
R04	Special cleaning for oxygen service
R05	Thermowell NACE approval
R06	Stainless steel plug and chain
R07 <sup>(15)</sup>	Full penetration weld
R09 <sup>(15)(16)</sup>	Concentric serrations of thermowell flange face
R10 <sup>(13)(14)</sup>	Thermowell flat faced flange
R11	Thermowell vent hole
R14	Thermowell special surface finish (12 R <sub>a</sub> Max) (Maximum (U) length = 22.5 in.)
R16 <sup>(13)(14)</sup>	Ring joint flange (Not available with 0-in. (T) length)
R20	Electropolishing
R21	Thermowell Wake Frequency Calculation (Configuration Data Sheet required)
R22	Internal pressure testing
R23	Brass plug and chain
R24	CRN Marking for British Columbia
R25	CRN Marking for Alberta
R26	CRN Marking for Saskatchewan
R27	CRN Marking for Manitoba
R28	CRN Marking for Ontario
R29	CRN Marking for Quebec
R30	CRN Marking for New Brunswick
R31	CRN Marking for Nova Scotia
R32	CRN Marking for Prince Edward Island
R33	CRN Marking for Yukon Territory
R34	CRN Marking for Northwest Territory
R35	CRN Marking for Nunavut
R36	CRN Marking for Newfoundland and Labrador
R37	Thermowell from Hex stock

### Mounting Adapters, Lead Wire Extensions, Connectors, and Seals

M5-M7	Mounting adapters
-------	-------------------

### Assembly Options

XA <sup>(17)</sup>	Assemble connection head or transmitter to a sensor assembly (PTFE paste where appropriate, fully wired.)
--------------------	---

- (1) This option is not available with explosion-proof approval option codes E1, E5, E6, or E7.
- (2) Bayonet spring-loaded style available to 45 inches. Codes 31 - 35 are not available with Sensor Lead Wire Termination codes R or P.
- (3) Codes A and C must be used with an extension length. Additional non-standard (E) lengths are available in 1/2-in. increments from 2.5 to 9-in.
- (4) Standard configuration with best delivery.
- (5) Available only with straight stem thermowells.
- (6) Thermowells with an overall length ("U" + "T" + 1.75-in.) of 36-in. or less are machined from solid barstock. Thermowells with an overall length larger than 42-in. will be constructed using a welded 3-piece design and are available only with a stepped stem style.
- (7) For additional (T) lengths, see Table 28 on page Temperature-57.
- (8) Straight or Tapered stem thermowells only.
- (9) Thermowells with an overall length ("U" + "T" + 1.75-in.) of 36-in. or less are machined with solid barstock. Thermowells with an overall length larger than 42-in. will be constructed using a welded 3-piece design and are available only with a stepped stem style.
- (10) For additional (T) lengths, see Table 28 on page Temperature-57.
- (11) Cannot be used with 0-in. (T) length. F08 cannot be used with 0- or 1/2-in. (T) length
- (12) Limited to 24" immersion length and 316 or 304 SST materials only.
- (13) SAA Flameproof approvals only applicable if installed with a Rosemount 248, 644, or 3144P transmitter.
- (14) ATEX Flameproof approval is only applicable if ordered with Sensor Lead Wire Terminator code D, R, T, P, or L (Rosemount connection head) or installed with Rosemount 248, 644, or 3144P transmitters.
- (15) Available on flanged thermowells only.
- (16) Only one flange face option allowed.
- (17) If ordering option code XA with a transmitter, specify the same option on the transmitter model code.

TABLE 21. Ordering Example

Typical Model Number	Model	Lead Wire Termination	Sensor Type	ISA Type	Extension Type	Extension Length	Material Code	Immersion Length	Mounting Style	Additional Options
		0183	N	21	J2	A	30	A	075	T22

## Comparison of Thermocouples

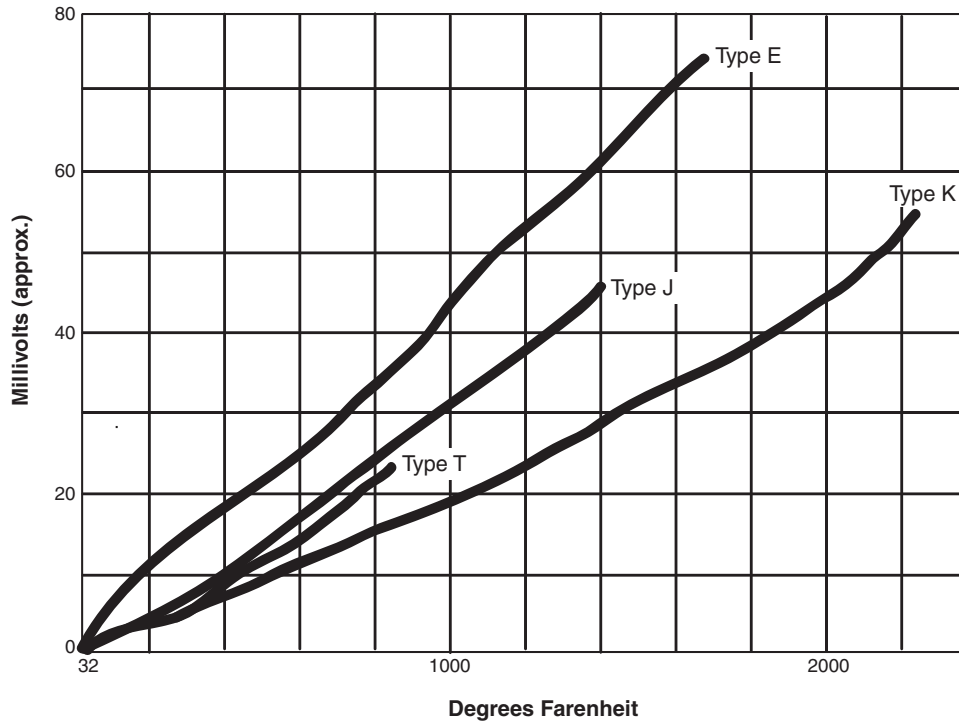

Thermocouple	Conditions for Use
Type J Iron / Constantan	Maximum operating temperature of 760 °C (1400 °F). Used with or without protective tubing where deficiency of free oxygen exists. Protective tube not essential, but desirable for cleanliness and longer service.
Type K Chromel / Alumel	Suitable for extended use in temperature reaching 1150 °C (2102 °F). Use of metal or ceramic protective tube desirable, especially in reducing atmospheres. In oxidizing atmospheres, protective tubing necessary only to promote cleanliness and longer service.
Type E Chromel / Constantan	Suitable for use at temperature up to 900 °C (1652 °F) in vacuum or inert, mildly oxidizing or reducing atmosphere. Not subject to corrosion at cryogenic temperatures. Has highest EMF output per degree of all commonly used thermocouples.
Type T Copper / Constantan	Operating temperature range of -180 to 371 °C (-292 to 700 °F). Use in either oxidizing or reducing atmospheres. Protective tubing necessary only to promote cleanliness and longer service. Stable at lower temperature. Superior for a wide variety of uses in cryogenic temperatures.

TABLE 22. Characteristics of Series 183 Thermocouple Types

ISA Thermocouple Types	Thermocouple Wire Alloys	Temperature Range		Limits of Error (Interchangeability)
		°C	°F	
J	Iron/Constantan	0 to 760	32 to 1400	±1.1 °C or ±0.4% of measured temperature, whichever is greater
K	Chromel/Alumel	0 to 1150	32 to 2102	±1.1 °C or ±0.4% of measured temperature, whichever is greater
E	Chromel/Constantan	0 to 871	32 to 1600	±1.0 °C or ±0.4% of measured temperature, whichever is greater
T	Copper/Constantan	-180 to 0	-292 to 32	±1.0 °C or ±1.5% of measured temperature, whichever is greater
		0 to 371	32 to 700	±0.5 °C or ±0.4% of measured temperature, whichever is greater

## Calibration

### CALIBRATION OPTIONS

Sensor calibration may be required for input to quality systems, or for control system enhancement. More frequently, it is used to improve the overall temperature measurement performance by matching the sensor to a temperature transmitter.

Transmitter-Sensor matching is available for RTD sensors used with Rosemount 644, 3144P, and 3244MV temperature transmitters where the inherent stability and repeatability of the RTD technology is well established.

### Transmitter-Sensor Matching Using Callendar-Van Dusen Constants

Significant temperature measurement accuracy improvement can be attained using a temperature sensor that is matched to a temperature transmitter. This matching process entails *teaching* the temperature transmitter the relationship between resistance and temperature for a specific RTD sensor. This relationship, approximated by the Callendar-Van Dusen equation, described as:

$R_t = R_0 + R_0\alpha[t - \delta(0.01t - 1)(0.01t) - \beta(0.01t - 1)(0.01t)^3]$ ,  
where:

$R_t$  = Resistance (ohms) at Temperature  $t$  (°C)

$R_0$  = Sensor-Specific Constant (Resistance at  $t = 0$  °C)

$\alpha$  = Sensor-Specific Constant

$\delta$  = Sensor-Specific Constant

$\beta$  = Sensor-Specific Constant (0 at  $t > 0$  °C, 0.11 at  $t < 0$  °C)

The exact values for  $R_0$ ,  $\alpha$ ,  $\delta$ ,  $\beta$ , – known as Callendar-Van Dusen (CVD) constants – are specific to each RTD sensor, and are established by testing each individual sensor at various temperatures.

The calibration temperature values using the CVD equation are divided into two major temperature areas: above 0 °C and below 0 °C. The calibration for the temperature range between 0 and 660 °C is obtained from the following formula:

$$R_t = R_0 \left\{ 1 + \alpha \left[ t - \delta \left( \frac{t}{100} \right) \left( \frac{t}{100} - 1 \right) \right] \right\}$$

Note that this is a modification of the fourth-order CVD equation where  $\beta = 0$  for temperatures greater than 0 °C. Since this modified equation is a second-order degree equation, at least three distinct temperature values are needed in order to curve fit the behavior of the RTD. For the temperature range from 0 to 100 °C only these two end points are used, and an approximation is made to render the constants.

Once the sensor-specific constants are entered, the transmitter uses them to generate a custom curve to best describe the relationship between resistance and temperature for the particular sensor and transmitter system. Matching a Series 68 or 78 RTD sensor to a 644, 3144P, and 3244MV transmitter typically results in a 3- or 4-fold improvement in temperature measurement accuracy for the total system. This substantial system accuracy improvement is realized as a result of the transmitter's ability to use the sensor's *actual* resistance-vs.-temperature curve instead of an *ideal* curve.

An example of the benefits of using the sensor matching capability of a Rosemount 3144P Temperature transmitter along with a matched Series 68 RTD sensor are shown in Typical Transmitter-Sensor Matching Uncertainty Improvements.

### Calibration Uncertainty

Calibration uncertainties of the lab are equal to or better than  $1/10$  IEC 751 Class B interchangeability:

$$\text{Uncertainty} = 0.03 + 0.0005 \times |t|$$

$$|t| = \text{absolute value of temperature in } ^\circ\text{C}$$

# Sensors and Accessories (English)

## TYPICAL TRANSMITTER-SENSOR MATCHING UNCERTAINTY IMPROVEMENTS

**Transmitter:** 3144 (has built-in sensor matching capabilities), span of 1 to 200 °C, accuracy = 0.1 °C)

**Sensor:** Series 68 RTD

**Callendar van Dusen Option:** V2

**Process Temperature:** 150 °C

Temperature		Sensor Interchangeability Error		Total Calibrated Sensor Uncertainty <sup>(1)</sup>	
°C	°F	°C	°F	°C	°F
0	32	±0.30	±0.54	±0.10	±0.18
50	122	±0.55	±0.99	±0.17	±0.31
100	212	±0.80	±1.44	±0.22	±0.40
150	302	±1.05	±1.89	±0.18	±0.32
200	392	±1.30	±2.34	±0.16	±0.29

(1) Includes calibration uncertainties of the lab, hysteresis, and repeatability.

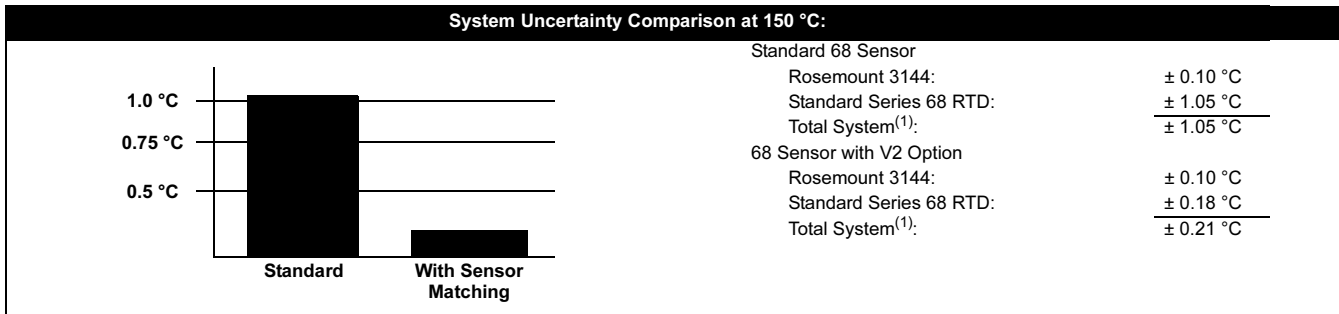

(1) Calculated using RSS statistical method:

$$SystemAccuracy = \sqrt{(TransmitterAccuracy)^2 + (SensorAccuracy)^2}$$

## ORDERING INFORMATION

### Sensor Characterization (Calibration) Schedules– Option Code V

Series 68, 68Q, and 78 RTD sensors can be ordered with an option (V1, V2,...V7, see Option Code “V” Callendar-van Dusen Constants), that provides Callendar-Van Dusen constants that are shipped with the sensor. When you order this option, the values of all four sensor-specific constants are physically attached to each sensor with a wire-on tag. Rosemount 644, 3144P, and 3244MV have a unique, built-in sensor matching capability. To use this capability, the four sensor-specific constants are programmed into the 644, 3144P, and 3244MV at the factory by ordering a C2 option on the transmitter, or easily entered and changed in the field using a HART Communicator or AMS. When these values are entered into a Rosemount 644, 3144P, and 3244MV, the sensor and transmitter become *matched*.

Each “V” option is specific to a particular temperature range for a given sensor type (see Option Code “V” Callendar-van Dusen Constants). As with option code X8Q4, the accuracies associated with each option code represent worst-case conditions when the sensor is used over the entire temperature range.

For applications requiring the increased accuracy obtainable through a matched sensor and transmitter, order the appropriate “V” option (see Option Code “V” Callendar-van Dusen Constants). To ensure optimal performance, select a “V” option such that the sensor’s range of actual operation is between the minimum and maximum calibration points.

The accuracy (uncertainty) of different calibration points varies because each calibration schedule has specific hysteresis and repeatability characteristics. For example, the accuracy of calibration points at 100 °C for options V1 and V2 differs because of the two different temperature ranges.

**NOTE**

An RTD ordered with the V option is shipped with CVD constants only; it does not include calibration tables.

**OPTION CODE “V” CALLENDAR-VAN DUSEN CONSTANTS**

Option Code	Temperature Range		Total Uncertainty <sup>(2)</sup> of Calibrated Sensor									
			Calibration Points		Uncertainty <sup>(1)</sup> of Calibration Lab		Series 68		Series 78 Standard		Series 78 High Temperature	
			°C	°F	°C	°F	°C	°F	°C	°F	°C	°F
V1 <sup>(3)</sup>	0 to 100	32 to 212	0	32	±0.03	±0.05	±0.06	±0.11	±0.06	±0.11	±0.06	±0.11
			100	212	±0.08	±0.14	±0.10	±0.18	±0.10	±0.18	±0.10	±0.18
V2 <sup>(3)</sup>	0 to 200	32 to 392	0	32	±0.03	±0.05	±0.10	±0.18	±0.09	±0.16	±0.10	±0.18
			100	212	±0.08	±0.14	±0.22	±0.40	±0.15	±0.27	±0.23	±0.41
			200	392	±0.13	±0.23	±0.16	±0.29	±0.15	±0.27	±0.16	±0.29
V3 <sup>(3)</sup>	0 to 400	32 to 752	0	32	±0.03	±0.05	±0.20	±0.29	±0.16	±0.29	±0.20	±0.29
			200	392	±0.13	±0.23	±0.42	±0.76	±0.29	±0.52	±0.44	±0.79
			400	752	±0.23	±0.41	±0.30	±0.54	±0.28	±0.50	±0.30	±0.54
V4 <sup>(3)(4)</sup>	0 to 600	32 to 1112	0	32	±0.03	±0.05	NA	±NA	NA	NA	NA	NA
			200	392	±0.13	±0.23	NA	±NA	NA	NA	NA	NA
			400	752	±0.23	±0.41	NA	±NA	NA	NA	NA	NA
V5 <sup>(3)</sup>	-50 to 100	-58 to 212	0	32	±0.03	±0.05	±0.08	±0.14	±0.06	±0.11	±0.09	±0.16
			100	212	±0.08	±0.14	±0.10	±0.18	±0.10	±0.18	±0.10	±0.18
V6 <sup>(3)</sup>	-50 to 200	-58 to 392	-50	-58	±0.06	±0.10	±0.14	±0.25	±0.11	±0.20	±0.14	±0.25
			0	32	±0.03	±0.05	±0.20	±0.36	±0.14	v0.25	±0.21	±0.38
			100	212	±0.08	±0.14	±0.26	±0.47	±0.18	±0.32	±0.27	±0.49
V7 <sup>(3)</sup>	-50 to 400	-58 to 752	200	392	±0.13	±0.23	±0.18	±0.32	±0.16	±0.29	±0.17	±0.3
			-50	-58	±0.06	±0.10	±0.23	±0.41	±0.19	±0.34	±0.23	±0.41
			0	32	±0.03	±0.05	±0.31	±0.56	±0.22	±0.40	±0.32	±0.58
			200	392	±0.13	±0.23	±0.46	±0.83	±0.31	±0.56	±0.48	±0.86
			400	752	±0.23	±0.41	±0.32	±0.58	±0.29	±0.52	±0.32	±0.58

- (1) Includes only the uncertainty of the lab.
- (2) Includes the uncertainty of the lab, hysteresis, and repeatability.
- (3) Uncertainties are valid for option code X8Q4 when ordered with the corresponding temperature range. The largest error shown in each temperature range is the worst case error for all points not shown in that range.
- (4) Only available with Series 78 High Temperature Sensors 10-in. or longer.

**Ordering Information**

Specify Sensor Model Number with “V” Option Example									
Sensor Model	0068	N	11	N	00	N	120	V2	

FIGURE 13. Typical Sensor Ordered with Option Code V

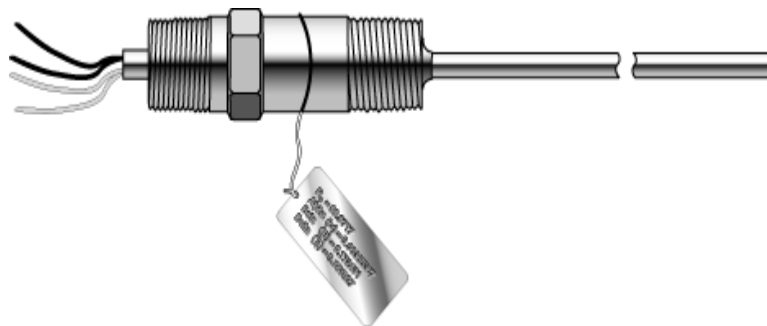

# Sensors and Accessories (English)

## Option Code X8Q4

The X8Q4 option calibrates the sensor to a customer-specified temperature range. The X8Q4 report includes the Callendar-Van Dusen (CVD) constants ( $R_0$ ,  $\alpha$ ,  $\delta$ ,  $\beta$ ), a resistance-versus-temperature table in one-degree increments, and a graph which includes the maximum errors due to the uncertainty of the calibration equipment, hysteresis, and repeatability. The values in the tables are calculated using Callendar-Van Dusen methodology. Two of the values on this table could be used to perform a two-point trim. The X8Q4 option also provides the CVD constants on a stainless steel tag attached to the sensor.

See Figure 16.

### Option X8Q4: Sensor Calibrated to a Customer-Specified Temperature Range

When you order an RTD with the X8Q4 option, you must specify a temperature range over which the sensor is to be calibrated. Before specifying the range, take careful note of the sensor temperature limits.

#### Ordering Example:

Typical Model Number	Model	Lead Wire Termination	Sensor Type	Extension Type	Extension Length	Thermowell Material	Immersion Length	Additional Options
	0068	N	11	N	00	N	045	X8Q4 X8X9Q4

If X8Q4 and X9Q4 are both required, do not repeat the "Q4" code in the model string. Include the following instead:  
Calibrate from -10 to 120 °C

FIGURE 14. Graph of a Typical Two-point Trim

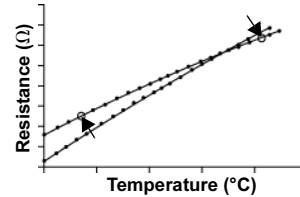

*A two-point trim shifts the ideal curve up or down, and changes the slope based on the two characterized points.*

## Option Code X9Q4

The X9Q4 option calibrates the sensor at a single customer-specified point. A calibration certificate with the resistance value at this point is supplied. This value could be used to perform a one-point trim on the transmitter. All characterizations are traceable to the National Institute of Standards and Technology (NIST). The calibration table is dated and marked with the sensor series and serial number.

See Figure 17.

#### NOTE

The X9Q4 option can be ordered and used in conjunction with the X8Q4 option.

FIGURE 15. Graph of a Typical One-point Trim

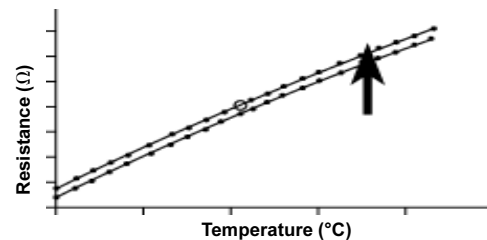

*A one-point trim shifts the ideal curve up or down based on the single characterized point.*

### Option X9Q4: Sensor Calibrated to a Customer-Specified Single Point

When you order an RTD with the X9Q4 option, you must specify a single temperature point at which the sensor is to be calibrated. Before specifying the point, take careful note of the sensor temperature limits.

#### Ordering Example:

Typical Model Number	Model	Lead Wire Termination	Sensor Type	Extension Type	Extension Length	Thermowell Material	Immersion Length	Additional Options
	0068	N	11	N	00	N	045	X9Q4 X8X9Q4

If X8Q4 and X9Q4 are both required, do not repeat the "Q4" code in the model string. Include the following instead:  
Calibrate at 50 °C

FIGURE 16. Example of Report Provided with X8Q4 Option

Date Report Printed: 8/15/03

**ROSEMOUNT INC.**

**REPORT OF CALIBRATION**  
**Model Option Code X8Q4**

*Industrial Platinum Resistance Thermometer (IPRT)*  
*Calibration Schedule 20C*

Sensor Serial Number:	915117
Sensor Model:	78
Sales Order Number:	1220333 2

**Rosemount Inc.**  
Customer Central  
8200 Market Blvd.  
Chanhassen, MN, USA 55317-9687  
1-800-999-9307

## **ROSEMOUNT INC.**

### **Report of Calibration**

*Industrial Platinum Resistance Thermometer (IPRT)*

#### *Callendar – Van Dusen Method Of Temperature Interpolation*

$$R_t = R_0 \left\{ 1 + \alpha \left[ t - \delta \left( \frac{t}{100} \right) \left( \frac{t}{100} - 1 \right) - \beta \left( \frac{t}{100} - 1 \right) \left( \frac{t}{100} \right)^3 \right] \right\}$$

Where:

- $R_t$  = Resistance at temperature  $t$ ,  $\Omega$
- $R_0$  = Resistance at temperature  $0^\circ\text{C}$
- $t$  = Temperature,  $^\circ\text{C}$
- $\alpha$ ,  $\beta$ , and  $\delta$  = Calibration Constants
- $\beta = 0$  for  $t > 0^\circ\text{C}$

#### *Alternate Form Of The Callendar – Van Dusen Interpolation Equation*

$$R_t = R_0 [1 + At + Bt^2 + Ct^3(t - 100)]$$

Where:

- $R_t$  = Resistance at temperature  $t$ ,  $\Omega$
- $R_0$  = Resistance at temperature  $0^\circ\text{C}$
- $t$  = Temperature,  $^\circ\text{C}$
- A, B, and C = Calibration Constants
- $C = 0$  for  $t > 0^\circ\text{C}$

The Callendar – Van Dusen method of temperature interpolation is the method utilized by the Rosemount Inc. 3144 and 3244 Temperature Transmitters.



## ROSEMOUNT INC.

### Report of Calibration

#### Industrial Platinum Resistance Thermometer (IPRT)

Calibration Schedule: 20C

Sensor Model: 78

Interpolation Method: Callendar-Van Dusen

Sensor Serial Number: 915117

Temp. (°C)	Resistance (Ohms)	Temp. (°C)	Resistance (Ohms)	Temp. (°C)	Resistance (Ohms)	Temp. (°C)	Resistance (Ohms)	Temp. (°C)	Resistance (Ohms)
0	99.978	48	118.586	96	136.929				
1	100.368	49	118.971	97	137.308				
2	100.758	50	119.356	98	137.688				
3	101.148	51	119.741	99	138.067				
4	101.538	52	120.125	100	138.446				
5	101.928	53	120.509						
6	102.318	54	120.894						
7	102.708	55	121.278						
8	103.098	56	121.662						
9	103.487	57	122.046						
10	103.876	58	122.430						
11	104.266	59	122.813						
12	104.655	60	123.197						
13	105.044	61	123.580						
14	105.433	62	123.964						
15	105.821	63	124.347						
16	106.210	64	124.730						
17	106.599	65	125.113						
18	106.987	66	125.496						
19	107.375	67	125.879						
20	107.764	68	126.262						
21	108.152	69	126.644						
22	108.540	70	127.026						
23	108.927	71	127.409						
24	109.315	72	127.791						
25	109.703	73	128.173						
26	110.090	74	128.555						
27	110.478	75	128.937						
28	110.865	76	129.319						
29	111.252	77	129.700						
30	111.639	78	130.082						
31	112.026	79	130.463						
32	112.413	80	130.844						
33	112.800	81	131.226						
34	113.186	82	131.607						
35	113.573	83	131.988						
36	113.959	84	132.368						
37	114.345	85	132.749						
38	114.731	86	133.130						
39	115.117	87	133.510						
40	115.503	88	133.890						
41	115.889	89	134.271						
42	116.275	90	134.651						
43	116.660	91	135.031						
44	117.046	92	135.411						
45	117.431	93	135.790						
46	117.816	94	136.170						
47	118.201	95	136.550						

**ROSEMOUNT INC.**

**Report of Calibration**

*Industrial Platinum Resistance Thermometer (IPRT)*

**Calibration Schedule:** 20C  
**Interpolation Method:** Callendar-Van Dusen

**Sensor Model:** 78  
**Sensor Serial Number:** 915117

**NIST TRACEABILITY**

<b>Sensor:</b>	<b>Calibration Bath:</b>		
	<b>0°C Bath</b>	<b>100°C Bath</b>	
<b><u>Primary Standard</u></b>			
<b>Manufacturer:</b>	Rosemount Aerospace	Rosemount Aerospace	
<b>Model Number:</b>	162CE	162CE	
<b>Serial Number:</b>	4746	4004	
<b>NIST Test Report Number:</b>	836/264032-00	836/262003-99	
<b>Calibration Date:</b>	9-13-00	7/9/99	
<b>Where Calibrated:</b>	NIST	NIST	
<b><u>Secondary Standard</u></b>			
<b>Manufacturer:</b>	Rosemount Aerospace	Rosemount Aerospace	
<b>Model Number:</b>	162CE	162CE	
<b>Serial Number:</b>	4155	4173	
<b>Calibration Date:</b>	4/25/01	3/23/00	
<b>Where Calibrated:</b>	Rosemount Aerospace	Rosemount Aerospace	
<b><u>Industrial PRT</u></b>			
<b>Manufacturer:</b>	<b>Rosemount Inc.</b>		<b>IPRT Calibrated By:</b> Employee Number: 11411 <u>Blong Lee</u>
<b>Sensor Model:</b>	78		
<b>Serial Number:</b>	915117		
<b>Calibration Date:</b>	7/24/03		
<b>Where Calibrated:</b>	Rosemount Inc., Chanhassen, MN		

*ITS-90 Temperature Scale values are utilized in this calibration process and report.*

**Definitions:**

*NIST* - National Institute of Standards and Technology

*ITS-90* - International Temperature Scale, 1990 revision.

*Primary Standard* - Standard PRT (SPRT) calibrated at NIST.

*Secondary Standard* - Rosemount Inc.'s Standard PRT (Secondary SPRT), calibrated against the primary standard.

*Industrial PRT (IPRT)* - The Rosemount model 58, 68, or 78 sensor that is the topic of this report, calibrated against the secondary standard(s) by comparison methodology.

FIGURE 17. Example of Report Provided with X9Q4 Option

Date Report Printed: 8/15/03

**ROSEMOUNT INC.**

**REPORT OF CALIBRATION**  
**Model Option Code X9Q4**

*Industrial Platinum Resistance Thermometer (IPRT)*  
*Calibration Schedule 212°F*

Sensor Serial Number: 912631  
Sensor Model: 78  
Sales Order Number: 1214169 1

**Rosemount Inc.**  
Customer Central  
8200 Market Blvd.  
Chanhassen, MN, USA 55317-9687  
1-800-999-9307

Page 1 of 2

**ROSEMOUNT INC.**  
**Report of Calibration (X9Q4)**  
*Industrial Platinum Resistance Thermometer (IPRT)*

**Calibration Schedule:** 212°F  
**Sensor Serial Number:** 912631

*Calibration Test Points*

Temperature (°F)	Resistance (ohms)
212.034	138.519

*Corrected Results*

Temperature	Resistance (ohms)
212.000 °F ( 100.000 °C)	138.512

<b>NIST* TRACEABILITY</b>			
<b><u>Primary Standard</u></b>		<b><u>Industrial PRT</u></b>	
<b>Manufacturer:</b>	Rosemount Aerospace	<b>Manufacturer:</b>	<b>Rosemount Inc.</b>
<b>Model Number:</b>	162CE	<b>Sensor Model:</b>	78
<b>Serial Number:</b>	4004	<b>Serial Number:</b>	912631
<b>NIST Test Report Number:</b>	836/262003-99	<b>Calibration Date:</b>	7/8/03
<b>Calibration Date:</b>	7/9/99	<b>Where Calibrated:</b>	Rosemount Inc., Chanhasen, MN
<b>Where Calibrated:</b>	NIST		
<b><u>Secondary Standard</u></b>		<b>IPRT Calibrated By:</b>	
<b>Manufacturer:</b>	Rosemount Aerospace	Employee Number: 11262	
<b>Model Number:</b>	162CE	<u>Jonathon Vought</u>	
<b>Serial Number:</b>	4173		
<b>Calibration Date:</b>	3/23/00		
<b>Where Calibrated:</b>	Rosemount Aerospace		

*ITS-90\*\* Temperature Scale values are utilized in this calibration process and report.*

\* *NIST* - National Institute of Standards and Technology  
 \*\* *ITS-90* - International Temperature Scale, 1990 revision.

# Sensors and Accessories (English)

TABLE 23. Option Code X9Q4 Calibration Uncertainties for the Series 68 and 78 Standard and High Temperature

Temperature		Uncertainty of Calibration Lab <sup>(1)</sup>		Total Uncertainty of Calibrated Sensor <sup>(2)</sup>	
°C	°F	°C	°F	°C	°F
-50	-58	0.06	0.10	0.07	0.13
0	32	0.03	0.05	0.06	0.11
100	212	0.08	0.14	0.09	0.16
200	392	0.13	0.23	0.14	0.25
400	752	0.23	0.41	0.24	0.43

(1) Includes only the uncertainty of the lab.

(2) Includes uncertainty of the lab and repeatability.

TABLE 24. Resistance vs. Temperature

IEC 751 Platinum 100, $\alpha = 0.00385$ RTD											
°F	Ohms	°F	Ohms	°F	Ohms	°C	Ohms	°C	Ohms	°C	Ohms
-330	18.04	210	138.08	690	235.15	-200	18.52	90	134.71	380	240.18
-320	20.44	220	140.19	700	237.09	-190	22.83	100	138.51	390	243.64
-310	22.83	230	142.29	710	239.02	-180	27.10	110	142.29	400	247.09
-300	25.20	240	144.39	720	240.95	-170	31.34	120	146.07	410	250.53
-290	27.57	250	146.49	730	242.87	-160	35.54	130	149.83	420	253.96
-280	29.93	260	148.58	740	244.79	-150	39.72	140	153.58	430	257.38
-270	32.27	270	150.67	750	246.71	-140	43.88	150	157.33	440	260.78
-260	34.61	280	152.75	760	248.62	-130	48.00	160	161.05	450	264.18
-250	36.94	290	154.83	770	250.53	-120	52.11	170	164.77	460	267.56
-240	39.26	300	156.91	780	252.44	-110	56.19	180	168.48	470	270.93
-230	41.57	310	158.98	790	254.34	-100	60.26	190	172.17	480	274.29
-220	43.88	320	161.05	800	256.24	-90	64.30	200	175.86	490	277.64
-210	46.17	330	163.12	810	258.14	-80	68.33	210	179.53	500	280.98
-200	48.46	340	165.18	820	260.03	-70	72.33	220	183.17	510	284.30
-190	50.74	350	167.24	840	263.80	-60	76.33	230	186.84	520	287.62
-180	53.02	360	169.30	850	265.68	-50	80.31	240	190.47	530	290.92
-170	55.29	370	171.35	860	267.56	-40	84.27	250	194.10	540	294.21
-160	57.55	380	173.40	870	269.44	-30	88.22	260	197.71	550	297.49
-150	59.81	390	175.45	880	271.31	-20	92.16	270	201.31	560	300.74
-140	62.06	400	177.49	890	273.17	-10	96.09	280	204.90	570	304.01
-130	64.30	410	179.53	900	275.04	0	100.00	290	208.48	580	307.25
-120	66.54	420	181.56	910	276.90	10	103.90	300	212.05	590	310.49
-110	68.77	430	183.59	920	278.75	20	107.79	310	215.61	600	313.71
-100	71.00	380	173.40	930	280.61	30	111.67	320	219.15	610	316.92
-90	73.22	390	175.45	940	282.46	40	115.54	330	222.68	620	320.12
-80	75.44	400	177.49	950	284.30	50	119.40	340	226.21	630	323.30
-70	77.66	410	179.53	960	286.14	60	123.24	350	229.72	640	326.48
-60	79.86	420	181.56	970	287.98	70	127.08	360	233.21	650	329.64
-50	82.07	430	183.59	980	289.82	80	130.90	370	236.70	660	332.79
-40	84.27	450	187.65	990	291.65						
-30	86.47	460	189.67	1000	293.48						
-20	88.66	470	191.68	1010	295.30						
-10	90.85	480	193.70	1020	297.12						
0	93.03	490	195.71	1030	298.94						
10	95.21	500	197.71	1040	300.75						
20	97.39	510	199.71	1050	302.56						
30	99.57	520	201.71	1060	304.37						
40	101.74	530	203.71	1070	306.17						
50	103.90	540	205.70	1080	307.97						
60	106.07	550	207.69	1090	309.77						
70	108.23	560	209.67	1100	311.56						
80	110.38	570	211.66	1110	313.35						
90	112.53	580	213.63	1120	315.14						
100	114.68	590	215.61	1130	316.92						
110	116.83	600	217.58	1140	318.70						
120	118.97	610	219.55	1150	320.47						
130	121.11	620	221.51	1160	322.24						
140	123.24	630	223.47	1170	324.01						
150	125.37	640	225.42	1180	325.77						
160	127.50	650	227.38	1190	327.53						
170	129.62	660	229.33	1200	329.29						
180	131.74	670	231.27	1210	331.04						
190	133.86	680	233.21								
200	135.97										

**Note**

To convert from °C to °F:  $\{1.8 \times (°C)\} + 32 = °F$   
Example:  $(1.8 \times 100) + 32 = 212 °F$

To convert from °F to °C:  $0.556 [(°F) - 32] = 100 °F$   
Example:  $0.556 (212 - 32) = 100 °C$

## Mounting Accessories

### ROSEMOUNT CONNECTION HEAD

The Rosemount Connection head is for general-purpose and spring-loaded sensors. The terminal block has six terminals for either single or dual element sensors. If the sensor assembly is ordered assembled to a Rosemount 248 or 644H head mount transmitter then the terminal block is replaced by the transmitters.

#### Specifications

##### Sensor Connection

- 1/2–14 NPT mounting thread. Screw terminals for lead wire connections.

##### Electrical Connection

- 1/2–14 NPT conduit

##### Materials of Construction

- Housing: Low copper aluminum
- Paint: Polyurethane
- Cover O-ring: Buna-N

##### Weight

- 18.5 oz (524 g)

##### Enclosure Rating

- NEMA 4X, IP66, and IP68

### POLYPROPYLENE CONNECTION HEAD

The polypropylene connection head (part number 00644-4198-0011) is designed for use with sanitary sensors. It is FDA-compliant, and is resistant to attack by acids, alkalies, and organic solvents.

#### Specifications

##### Sensor Connection

- 1/2–14 NPT mounting thread. Screw terminals for lead wire connections

##### Electrical Connection

- 1/2–14 NPT conduit

##### Materials of Construction

- Housing: White polypropylene polymer
- O-Ring Seal: Silicone rubber
- Terminals: Nickel-plated brass

##### Temperature Limits

- –73 to 104 °C (–100 to 220 °F)

##### Weight

- 0.5 lb

### CONNECTION HEAD

The Extended Cover Connection Head (P/N 00079-0324-xxxx) provides the additional space required by sensors that have bayonet connectors. This model can also be used with general-purpose and spring-loaded sensors. The terminal block has six terminals for either single- or dual-element sensors.

The Flat Cover Connection Head (P/N 00079-0325-xxxx) is for general-purpose and spring-loaded sensors. The terminal block has six terminals for either single- or dual-element sensors.

#### Specifications

##### Sensor Connection

- 1/2–14 ANPT mounting thread. Screw terminals for lead wire connections

##### Electrical Connection

- 3/4–14 ANPT conduit

##### Materials of Construction

- Housing: Low-copper aluminum alloy
- O-Ring Seal: Silicone rubber
- Terminals: Nickel-plated brass

##### Temperature Limits

Head Type	Unapproved	E5 option	E6 option	E1 option
Painted	–100 to 100 °C	–50 to 85 °C	–50 to 85 °C	–40 to 65 °C
	–148 to 212 °F	–58 to 185 °F	–58 to 185 °F	–40 to 149 °F
Unpainted	–100 to 200 °C	–50 to 85 °C	–50 to 200 °C	–40 to 65 °C
	–148 to 392 °F	–58 to 185 °F	–58 to 392 °F	–40 to 149 °F

##### Enclosure Ratings

- When installed properly, painted connection heads are suitable for indoor and outdoor NEMA 4X and CSA Enclosure Type 4X installations. When installed properly, unpainted connection heads are suitable for NEMA 4 and CSA Enclosure Type 4 installations. See Hazardous Area Approvals for complete installation information

##### Weight

- 2 lb 8 oz (extended cover)
- 1 lb 9 oz (flat cover)

# Sensors and Accessories (English)

## Connection Head Model Numbers

Model	Description
00644-4410-0011	Rosemount Connection Head, painted aluminum
007903252003	Six Terminals with Flat Cover, Unapproved, Unpainted
007903242003	Six Terminals with Extended Cover, Unapproved, Unpainted
007903250002	Six Terminals with Flat Cover, FM Approved, Unpainted
007903240002	Six Terminals with Extended Cover, FM Approved, Unpainted
007903250003	Six Terminals with Flat Cover, CSA Approved, Unpainted
007903240003	Six Terminals with Extended Cover, CSA Approved, Unpainted
007903252005	Six Terminals with Flat Cover, Unapproved, Painted
007903242005	Six Terminals with Extended Cover, Unapproved, Painted
007903250004	Six Terminals with Flat Cover, FM Approved, Painted
007903240004	Six Terminals with Extended Cover, FM Approved, Painted
007903250005	Six Terminals with Flat Cover, CSA Approved, Painted
007903240005	Six Terminals with Extended Cover, CSA Approved, Painted
00644-4198-0011	No Approval Options, White Polypropylene
00065-0305-0001	Round Terminal Block for Rosemount and Polypropylene heads
006444-4431-0001	External ground Screw Assembly for Rosemount Connection Head
00644-4435-0011	Polypropylene Connection Head with Terminal Block 1/2 in. NPT entries
00079-0329-0001	Kit of 12 Silicone Rubber O-rings for Flat/Extended Heads

## Connection Head Dimensional Drawing

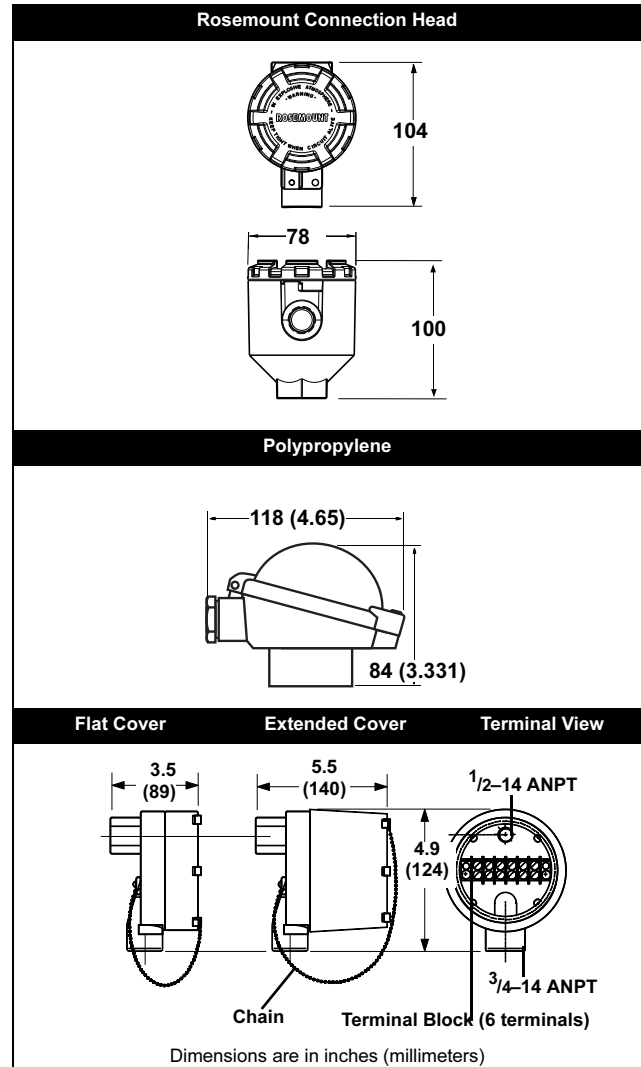

**EXTENSION FITTING ASSEMBLIES**

Extension fitting assemblies are available in

- a coupling and nipple assembly
- a union and nipple assembly

FIGURE 18. Extension Fitting

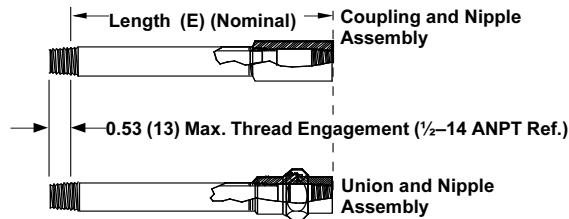

Dimensions are in inches (millimeters)

TABLE 25. Extension

Coupling and Nipple, SST		Union and Nipple, SST	
Model Number	Length (E)	Model Number	Length (E)
007903540250	2.5-in.	007903550250	2.5-in.
007903540300	3.0-in. <sup>(1)</sup>	007903550300	3.0-in. <sup>(1)</sup>
007903540350	3.5-in.	007903550350	3.5-in.
007903540400	4.0-in.	007903550400	4.0-in.
007903540450	4.5-in.	007903550450	4.5-in.
007903540500	5.0-in.	007903550500	5.0-in.
007903540550	5.5-in.	007903550550	5.5-in.
007903540600	6.0-in. <sup>(1)</sup>	007903550600	6.0-in. <sup>(1)</sup>
007903540650	6.5-in.	007903550650	6.5-in.
007903540700	7.0-in.	007903550700	7.0-in.
007903540750	7.5-in.	007903550750	7.5-in.
007903540800	8.0-in.	007903550800	8.0-in.
007903540850	8.5-in.	007903550850	8.5-in.
007903540900	9.0-in.	007903550900	9.0-in.

<sup>(1)</sup> Standard configuration with best delivery. Also available for emergency requirements. Consult factory for information.

**Choosing an Extension**

Aside from ambient temperature variations, the heat from the process is transferred from the thermowell to the transmitter housing. If the process temperature is near or beyond specification limits, consider the use of additional thermowell lagging, an extension nipple, or a remote mounting configuration to isolate the transmitter from the excessive temperatures. Use Figure 20 and the example below to determine an adequate thermowell extension length.

FIGURE 19. 3144 Transmitter Housing Temperature Rise versus Extension Length for a Test Installation

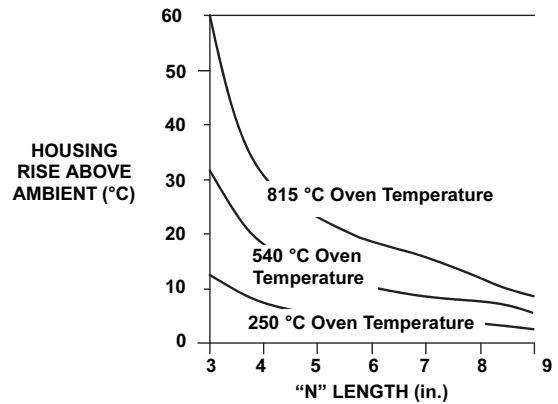

**Example**

The rated ambient temperature specification is 85 °C. If the maximum ambient temperature is 40 °C and the process temperature to be measured is 540 °C, the maximum allowable housing temperature rise is the rated temperature specification limit minus the existing ambient temperature (85 – 40), or 45 °C. As shown in Figure 19, an extension (E) dimension of 3.0-in (76 mm) will result in a housing temperature rise of 30 °C. An “E” dimension of 3-in. would therefore be the minimum recommended length, and would provide a safety factor of about 15 °C. A longer “E” dimension, such as 6-in. (152 mm), would be desirable in order to reduce errors caused by transmitter temperature effect, although in that case the transmitter would probably require extra support. If a thermowell with lagging is used, the “E” dimension may be reduced by the length of the lagging.

# Sensors and Accessories (English)

## MOUNTING ADAPTERS FOR SERIES 58, 68, 78, AND 183

### M5–M7, Sensor Compression Fittings, 316 SST

- For adjustable sensor length.
- For low pressure applications (100 psig maximum).
- Fits ¼-inch diameter sensors.
- Available with 1/8–27 (M5), 1/4–18 (M6), and 1/2–14 (M7) ANPT process threads.
- Not available on spring-loaded sensors.

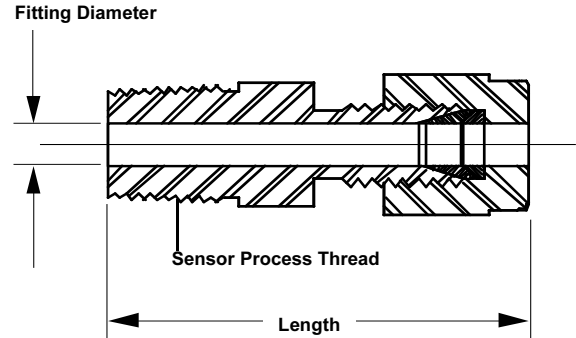

TABLE 26. Compression Fittings, 316 SST  
(for attachment to the stem of the capsule)

Model Number	Option Code	Sensor Process Thread	Fitting Diameter		Length	
			in.	mm	in.	mm
C07961-0005	M5	1/8–27 ANPT	0.25	6.35	1.31	33.27
C07961-0006	M6	1/4–18 ANPT	0.25	6.35	1.5	38.1
C07961-0008	M7	1/2–14 ANPT	0.25	6.35	1.75	44.45

# Product Data Sheet

00813-0100-2654, Rev GA

March 2008

# Sensors and Accessories (English)

## LEAD WIRE EXTENSIONS, CONNECTORS, AND SEALS

The following options are available on most Series 68 and 78 sensors. They are not available for use on Series 58C, 68Q, and 183 sensors or with SAA or ATEX/ISSEp Flameproof approval (Option Codes E7 or E1).

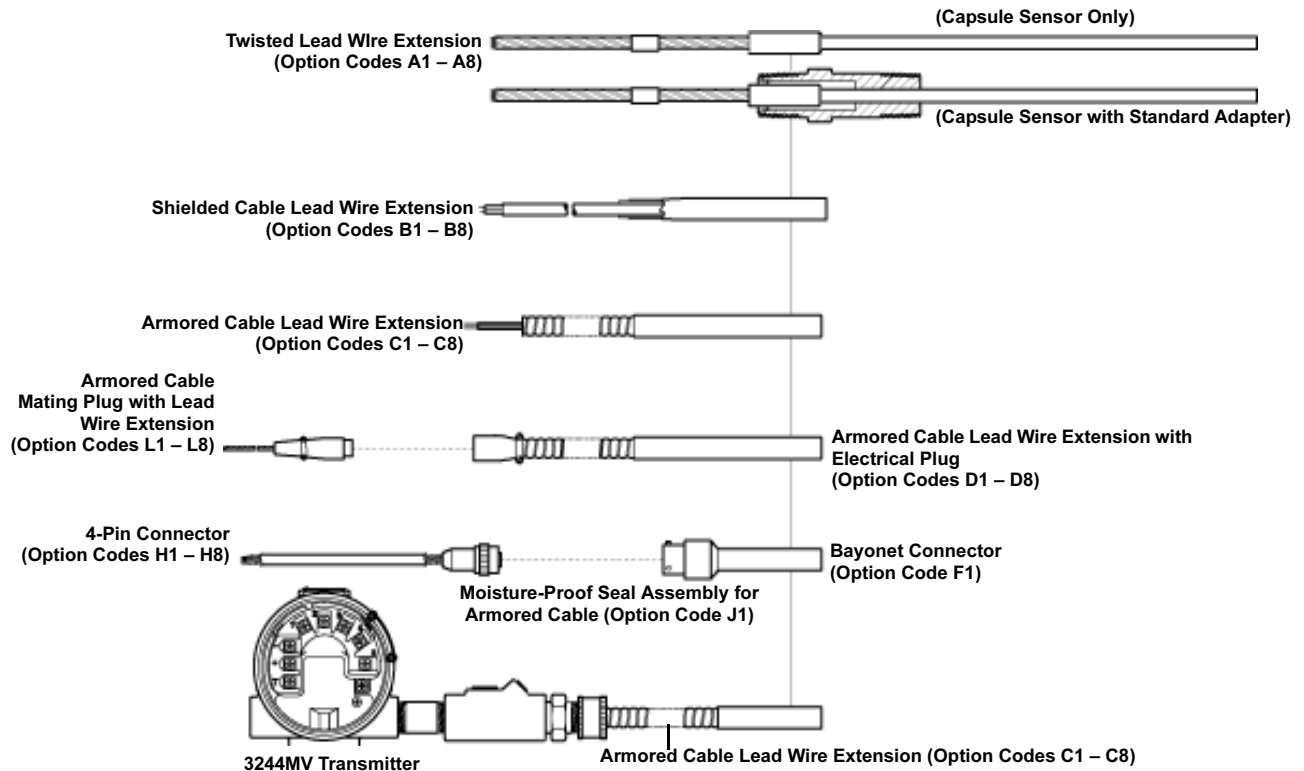

### A1–A8, Twisted Lead Wire Extension

- Lead wire connections are silver brazed and individually insulated by shrinkable PTFE tubes
- Withstands 95 percent relative humidity
- 200° C (392° F) maximum temperature
- Available with single or dual-element sensors

Option Code	Y Length (ft)
A1	1 1/2
A2	3
A3	6
A4	12

Option Code	Y Length (ft)
A5	24
A6	50
A7	75
A8	100

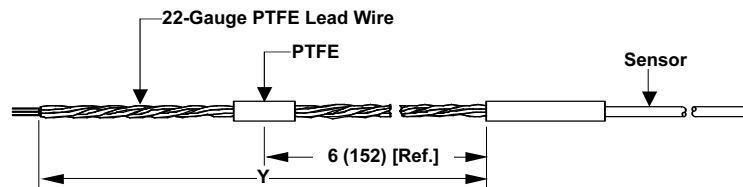

Not available for use with Series 68Q Sanitary RTDs and 183 thermocouples or with SAA or ATEX/ISSEp flameproof approval (option codes E7 or E1)

Dimensions are in inches (millimeters)

# Sensors and Accessories (English)

## B1–B8, Shielded Cable Lead Wire Extension

- Copper shielded cable prevents electrical noise distortions to sensor signal output
- Withstands 95 percent relative humidity
- 200° C (392° F) maximum temperature

Option Code	Y Length (ft)
B1	1 1/2
B2	3
B3	6
B4	12

Option Code	Y Length (ft)
B5	24
B6	50
B7	75
B8	100

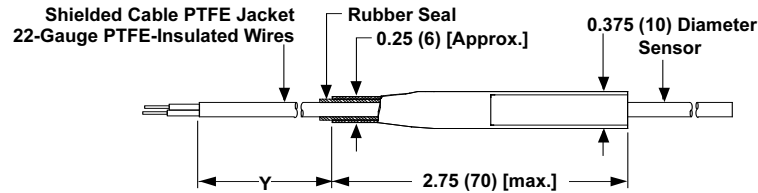

Not available for 58C, 68Q, and 183 sensors or with SAA or ATEX/ISseP flameproof approval (option codes E7 or E1)  
 Dimensions are in inches (millimeters)

## C1–C8, Armored Cable Lead Wire Extension

- Provides lead wire protection in heavy duty environments.
- Withstands 95 percent relative humidity
- 200° C (392° F) maximum temperature
- Available with single or dual-element sensors

Option Code	Y Length (ft)
C1	1 1/2
C2	3
C3	6
C4	12

Option Code	Y Length (ft)
C5	24
C6	50
C7	75
C8	100

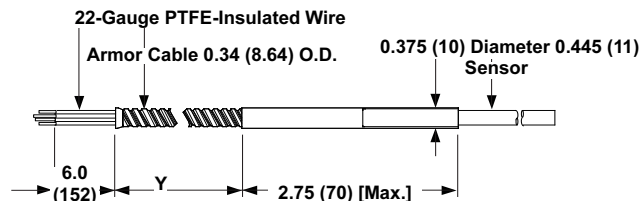

Not available for 58C, 68Q, and 183 sensors or with SAA or ATEX/ISseP flameproof approval (option codes E7 or E1)  
 Dimensions are in inches (millimeters)

## D1–D8, ARMORED CABLE LEAD WIRE EXTENSION WITH ELECTRICAL PLUG

- Provides lead wire protection in heavy-duty environments
- Provides quick-disconnect capability
- Withstands 95 percent relative humidity

Option Code	Y Length (ft)
D1	1 1/2
D2	3
D3	6
D4	12

Option Code	Y Length (ft)
D5	24
D6	50
D7	75
D8	100

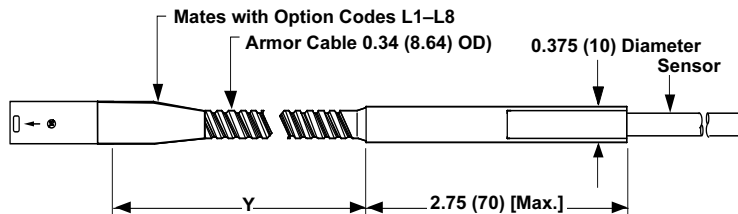

Not available for 58C, 68Q, and 183 sensors or with SAA or ATEX/ISseP flameproof approval (option codes E7 or E1)  
 Dimensions are in inches (millimeters)

# Product Data Sheet

00813-0100-2654, Rev GA

March 2008

# Sensors and Accessories (English)

## L1–L8, ARMORED CABLE MATING PLUG WITH LEAD WIRE EXTENSION

- Completes quick-disconnect capability for armored cable
- Withstands 95 percent relative humidity
- Twisted lead wire extension for lowest cost installation

Option Code	Y Length (ft)
L1	1 1/2
L2	3
L3	6
L4	12

Option Code	Y Length (ft)
L5	24
L6	50
L7	75
L8	100

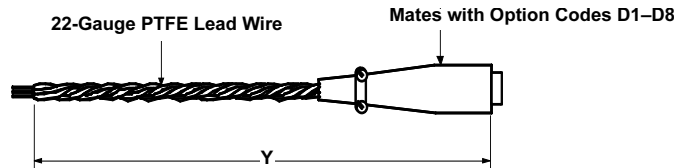

Not available for 58C, 68Q, and 183 sensors or with SAA or ATEX/ISSeP flameproof approval (option codes E7 or E1)

Dimensions are in inches (millimeters)

## F1, 4-PIN BAYONET CONNECTOR

- Provides quick-disconnect capability
- Withstands 100 percent relative humidity with connector mate
- Available for capsule and general purpose with 4-wire lead wire configuration only

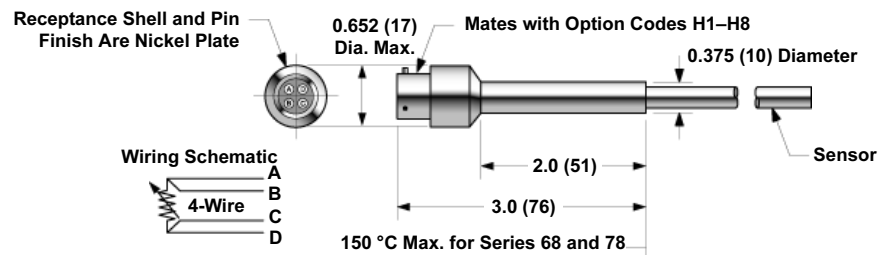

Not available for 58C, 68Q, and 183 sensors, or with FM or CSA explosion-proof, or with SAA or ATEX/ISSeP flameproof approval (option codes E5, E6, E7, or E1)

Dimensions are in inches (millimeters)

## H1–H8, 4-PIN CONNECTOR MATING PLUG WITH LEAD WIRE EXTENSION

- Completes the quick-disconnect capability of connector
- Provides twisted lead wire extension for remote installations
- Withstands 100 percent relative humidity with connector mate
- F1 connector is required if H1–H8 lead wire extension is used

Option Code	Y Length (ft)
H1	1 1/2
H2	3
H3	6
H4	12

Option Code	Y Length (ft)
H5	24
H6	50
H7	75
H8	100

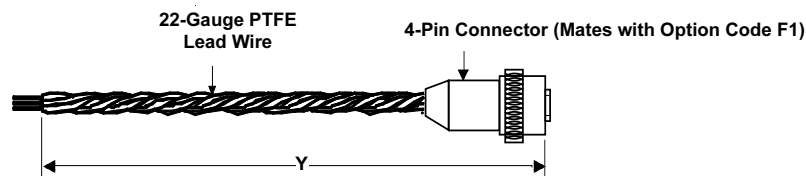

Not available for 58C, 68Q, and 183 sensors, or with FM or CSA explosion-proof, or with SAA or ATEX/ISSeP flameproof approval (option codes E5, E6, E7, or E1)

Dimensions are in inches (millimeters)

# Sensors and Accessories (English)

## J1, MOISTURE-PROOF SEAL ASSEMBLY FOR ARMORED CABLE

- Prevents moisture migration through armored cable
- For use in humid environments but not for direct liquid immersion
- Non-disconnectable type assembly with armored cable and sensor

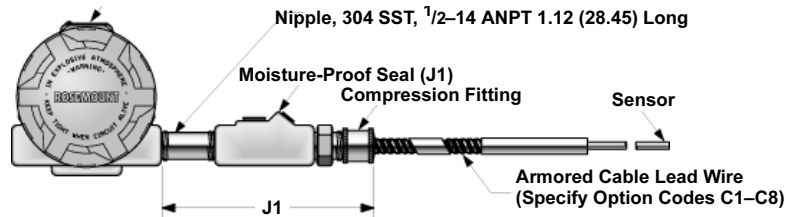

Not available for 58C, 68Q, and 183 sensors, or with FM or CSA explosion-proof, or with SAA or ATEX/ISSEp flameproof approval (option codes E5, E6, E7, or E1).

Moisture-proof seal assembly must be ordered with armored cable lead wire extension (option codes C1 – C8)

Dimensions are in inches (millimeters)

## THERMOWELLS

To simplify ordering, the previous Series 79, 80, and 81 thermowell offerings are all included in the new Series 91 thermowell option.

### Materials

Rosemount Thermowells are supplied in most materials required for industrial applications. Standard materials are 316 SST, 304 SST, and C1018 carbon steel. For corrosive environments, special materials such as Monel®, Hastelloy®, and Inconel 600 are available. Consult factory for other material availability.

### Strength (Pressure and Flow Vibration)

The strength of a thermowell depends on several parameters that relate thermowell construction to the installation environment. For most industrial applications, standard Rosemount thermowells provide the necessary strength if the material, style, and length are correct for the application. The proper selection of a thermowell depends on fluid type, temperature, pressure, and fluid velocity. It is important to note that most thermowell failures are caused by vibration that is induced by fluid flow. If static pressure strength is a major consideration, refer to Table 27 for standard material ratings for a 1/2-inch tip. Tapered thermowells are offered for additional strength.

### Strength Calculation

Rosemount Inc. has the ability to perform thermowell frequency calculations to verify that the thermowell dimensions you provide are appropriate for your specific application. To take advantage of this calculation, fill out and return the Configuration Data Sheet.

### Construction

All thermowell bodies with an overall length less than 42-in. are machined from solid bar stock to ensure water-tightness. Flange mounts are welded to the thermowell body. Standard construction provides immersion lengths (U) from 2½ to 48 inches with overall lengths (L) from 4 to 59 inches respectively. Thermowells with overall lengths larger than 42-in. will be a 3-piece welded construction. Consult the factory for more information on welded 3-piece construction thermowells.

### Identification Data

The part number is etched on each thermowell. Additional tagging for specific customer requirements is available.

### Installation

For dimensional drawings of Thread Mounted, Weld Mounted, and Flange Mounted Thermowells, refer to Figure 20, 22, and 24.

TABLE 27. Thermowell Material Rating

Material	Recommended Usage	Process Rating <sup>(1)</sup> (psi) at Temperature (°F)						
		0 °F	300 °F	500 °F	700 °F	900 °F	1100 °F	1300 °F
304 SST	Good resistance to oxidation	5600	4800	4700	4600	3400	2400	780
316 SST	Good resistance to corrosion. Better resistance to chemical attack than 304 SST	5600	5400	5300	5200	4400	3200	1250
Carbon Steel	For non-corrosive service	3700	3700	3700	3650	2000	—	—

(1) In case of an explosion, the integrity of the thermowell is maintained to the specified pressures.

**ORDERING INFORMATION**

TABLE 28. Series 91 Thermowells

Model	Description
0091	Series 0091 Thermowells

Code	Thermowell Material	Code	Thermowell Material	Code	Thermowell Material
A	Type 316 SST	G	Monel	R	Nickel 200
B	Type 304 SST	H	Inconel 600	T	Titanium
C	Carbon Steel	J	Hastelloy C (304 SST Flange, if flange style is ordered)	U <sup>(2)</sup>	316 SST with tantalum sheath
D	316L SST	L	Hastelloy B (304 SST Flange, if flange style is ordered)	V	310 SST
E	304L SST	M	304 SST with PTFE coating	W	321 SST
F	Alloy 20	P	Chrome Molybdenum F22	Z	Chrome Molybdenum F11

Code	Length (U) in inches <sup>(1)</sup>	Code	Length (U) in inches <sup>(1)</sup>	Code	Length (U) in inches <sup>(1)</sup>
015 <sup>(2)</sup>	1.5	130	13.0	260	26.0
020	2.0	135	13.5	270	27.0
025	2.5	140	14.0	280	28.0
030	3.0	145	14.5	290	29.0
035	3.5	150	15.0	300	30.0
040	4.0	155	15.5	310	31.0
045	4.5	160	16.0	320	32.0
050	5.0	165	16.5	330	33.0
055	5.5	170	17.0	340	34.0
060	6.0	175	17.5	350	35.0
065	6.5	180	18.0	360	36.0
070	7.0	185	18.5	370	37.0
075	7.5	190	19.0	380	38.0
080	8.0	195	19.5	390	39.0
085	8.5	200	20.0	400	40.0
090	9.0	205	20.5	410	41.0
095	9.5	210	21.0	420	42.0
100	10.0	215	21.5	430	43.0
105	10.5	220	22.0	440	44.0
110	11.0	225	22.5	450	45.0
115	11.5	230	23.0	460	46.0
120	12.0	240	24.0	470	47.0
125	12.5	250	25.0	480	48.0

Code	Thermowell Mounting Style	Stem Style	Tip A (in.)	Root B (in.)
T20	Thread, 1/2-14 ANPT	Stepped	0.50	0.63
T22	Thread, 3/4-14 ANPT	Stepped	0.50	0.75
T24	Thread, 1-11.5 ANPT	Stepped	0.50	0.88
T26	Thread, 3/4-14 ANPT	Tapered	0.63	0.88
T28	Thread, 1-11.5 ANPT	Tapered	0.63	1.06
T30	Thread, 1 1/2-11.5 ANPT	Tapered	0.75	1.50
T32	Thread, 1/2-14 ANPT	Straight	0.50	0.50
T34	Thread, 3/4-14 ANPT	Straight	0.75	0.75
T36	Thread, 1-11.5 ANPT	Straight	0.75	0.75
T38	Thread, 3/4-14 ANPT	Straight	0.50	0.50
T44	Thread, 1/2-14 ANPT	Tapered	0.50	0.63
W38	Weld, 3/4-in. pipe	Stepped	0.50	0.75
W40	Weld, 1-in. pipe	Stepped	0.50	0.88
W42	Weld, 3/4-in. pipe	Tapered	0.63	0.88
W44	Weld, 1-inch Pipe,	Tapered	0.75	1.00
W46	Weld, 1 1/4-inch Pipe	Tapered	0.75	1.25
W48	Weld, 3/4-inch Pipe	Straight	0.75	0.75
W50	Weld, 1-inch Pipe	Straight	0.75	0.75
F10	Flange, F = 2-inch, Class 150	Straight	0.75	0.75

Ordering Options Continued on Next Page

# Sensors and Accessories (English)

Code	Thermowell Mounting Style	Stem Style	Tip A (in.)	Root B (in.)
F12	Flange, F = 3-inch, Class 150	Straight	0.75	0.75
F52	Flange, F = 1-inch, Class 150	Stepped	0.50	0.75
F54	Flange, F = 1½-inch, Class 150	Stepped	0.50	0.75
F56	Flange, F = 2-inch, Class 150	Stepped	0.50	0.75
F58	Flange, F = 1-inch, Class 150	Tapered	0.75	1.00
F60	Flange, F = 1½-inch, Class 150	Tapered	0.75	1.00
F62	Flange, F = 2-inch, Class 150	Tapered	0.75	1.25
F64	Flange, F = 1-inch, Class 150	Straight	0.75	0.75
F66	Flange, F = 1½-inch, Class 150	Straight	0.75	0.75
F70	Flange, F = 1-inch, Class 300	Stepped	0.50	0.75
F72	Flange, F = 1½-inch, Class 300	Stepped	0.50	0.75
F74	Flange, F = 2-inch, Class 300	Stepped	0.50	0.75
F76	Flange, F = 1-inch, Class 300	Tapered	0.75	1.00
F78	Flange, F = 1½-inch, Class 300	Tapered	0.75	1.00
F80	Flange, F = 2-inch, Class 300	Tapered	0.75	1.25
F82	Flange, F = 1-inch, Class 300	Straight	0.75	0.75
F84	Flange, F = 1½-inch, Class 300	Straight	0.75	0.75
F86	Flange, F = 2-inch, Class 300	Straight	0.75	0.75
F88 <sup>(3)</sup>	Flange, F = 1-inch, Class 600	Stepped	0.50	0.75
F90 <sup>(3)</sup>	Flange, F = 1½-inch, Class 600	Stepped	0.50	0.75
F92 <sup>(3)</sup>	Flange, F = 2-inch, Class 600	Stepped	0.50	0.75
F94 <sup>(3)</sup>	Flange, F = 1-inch, Class 600	Tapered	0.75	1.00
F96 <sup>(3)</sup>	Flange, F = 1½-inch, Class 600	Tapered	0.75	1.00
F98 <sup>(3)</sup>	Flange, F = 2-inch, Class 600	Tapered	0.75	1.25
F02 <sup>(3)</sup>	Flange, F = 1-inch, Class 600	Straight	0.75	0.75
F04 <sup>(3)</sup>	Flange, F = 1½-inch, Class 600	Straight	0.75	0.75
F06 <sup>(3)</sup>	Flange, F = 2-inch, Class 600	Straight	0.75	0.75
F16 <sup>(3)</sup>	Flange, F = 1½-inch, Class 900	Tapered	0.75	1.00
F34 <sup>(3)</sup>	Flange, F = 1½-inch, Class 1500	Tapered	0.75	1.00
F24 <sup>(3)</sup>	Flange, F = 2-inch, Class 1500	Tapered	0.75	1.25
F08 <sup>(4)</sup>	Flange, F = 1½-inch, Class 2500	Tapered	0.75	1.00
Q02 <sup>(5)</sup>	Sanitary, 1-in., Tri-Clamp	Stepped	0.50	0.75
Q04 <sup>(6)</sup>	Sanitary, 1½-in., Tri-Clamp	Stepped	0.50	0.75
Q06 <sup>(6)</sup>	Sanitary, 2-in., Tri-Clamp	Stepped	0.50	0.75
Q08 <sup>(6)</sup>	Sanitary, 3-in., Tri-Clamp	Stepped	0.50	0.75
Q20 <sup>(6)</sup>	Sanitary, ¾-in., Tri-Clamp	Straight	0.44	0.44
Q22 <sup>(6)</sup>	Sanitary, 1-in., Tri-Clamp	Straight	0.50	0.50
Q24 <sup>(6)</sup>	Sanitary, 1½-in., Tri-Clamp	Straight	0.50	0.50
Q26 <sup>(6)</sup>	Sanitary, 2-in., Tri-Clamp	Straight	0.50	0.50
Q28 <sup>(6)</sup>	Sanitary, 3-in., Tri-Clamp	Straight	0.50	0.50

Code	Thermowell Lagging Length (T) in.	Code	Thermowell Lagging Length (T) in.	Code	Thermowell Lagging Length (T) in.
T000	0.0	T035	3.5	T070	7.0
T005	0.5	T040	4.0	T075	7.5
T010	1.0	T045	4.5	T080	8.0
T015	1.5	T050	5.0	T085	8.5
T020	2.0	T055	5.5	T090	9.0
T025	2.5	T060	6.0	T095	9.5
T030	3.0	T065	6.5		

Code	Instrument Connection Thread
P	½-14 NPSM
D	½-14 ANPT for CSA

Code	Additional Options
<b>Thermowell Options</b>	
Q8	Thermowell material certificate
R01 <sup>(6)</sup>	Thermowell special external pressure testing
R03	Thermowell dye penetration testing
R04	Special cleaning for oxygen service

Ordering Options Continued on Next Page

# Product Data Sheet

00813-0100-2654, Rev GA

March 2008

# Sensors and Accessories (English)

Code	Additional Options
R05	Thermowell NACE approval
R06	Stainless steel plug and chain
R07 <sup>(7)</sup>	Full penetration weld
R09 <sup>(7)(8)</sup>	Concentric serrations of thermowell flange face
R10 <sup>(7)(8)</sup>	Thermowell flat faced flange
R11	Thermowell vent hole
R14 <sup>(9)</sup>	Thermowell special surface finish (12 R <sub>a</sub> Max) (Maximum (U) length = 22.5 in.)
R16 <sup>(3)(7)(8)</sup>	Ring joint flange (Not available with 0-in. (T) length)
R20 <sup>(10)</sup>	Electropolishing
R21	Thermowell Wake Frequency Calculation (Configuration Data Sheet required)
R22	Internal pressure testing
R23	Brass plug and chain
R24	CRN Marking for British Columbia
R25	CRN Marking for Alberta
R26	CRN Marking for Saskatchewan
R27	CRN Marking for Manitoba
R28	CRN Marking for Ontario
R29	CRN Marking for Quebec
R30	CRN Marking for New Brunswick
R31	CRN Marking for Nova Scotia
R32	CRN Marking for Prince Edward Island
R33	CRN Marking for Yukon Territory
R34	CRN Marking for Northwest Territory
R35	CRN Marking for Nunavut
R36	CRN Marking for Newfoundland and Labrador
R37	Thermowell from Hex stock

(1) Thermowells with an overall lengths ("U" + "T" + 1.75-in.) of 36-in. or less are machined from solid bar stock. Thermowells with an overall length larger than 42-in. will be constructed using a welded 3-piece design and are available only with a stepped stem style.

(2) Available in straight stem only

(3) Not available with 0-in. (T) length.

(4) Not available with 0- or 1/2-in. (T) length.

(5) Limited to 24" immersion length and 316 or 304 SST materials only.

(6) Maximum (U) length = 42.0-in.

(7) Available on flanged thermowells only.

(8) Only one flange face option allowed.

(9) Maximum (U) length = 22.5 inches.

(10) Not available on flanged thermowells and L lengths longer than 24".

## Ordering Example

Typical Model Number	Model	Material	Immersion Length	Mounting Style	Lagging Length	Connection Thread	Additional Options
	0091	A	030	F52	T040	P	R01 R05 R07

FIGURE 20. Thread Mounted Thermowells

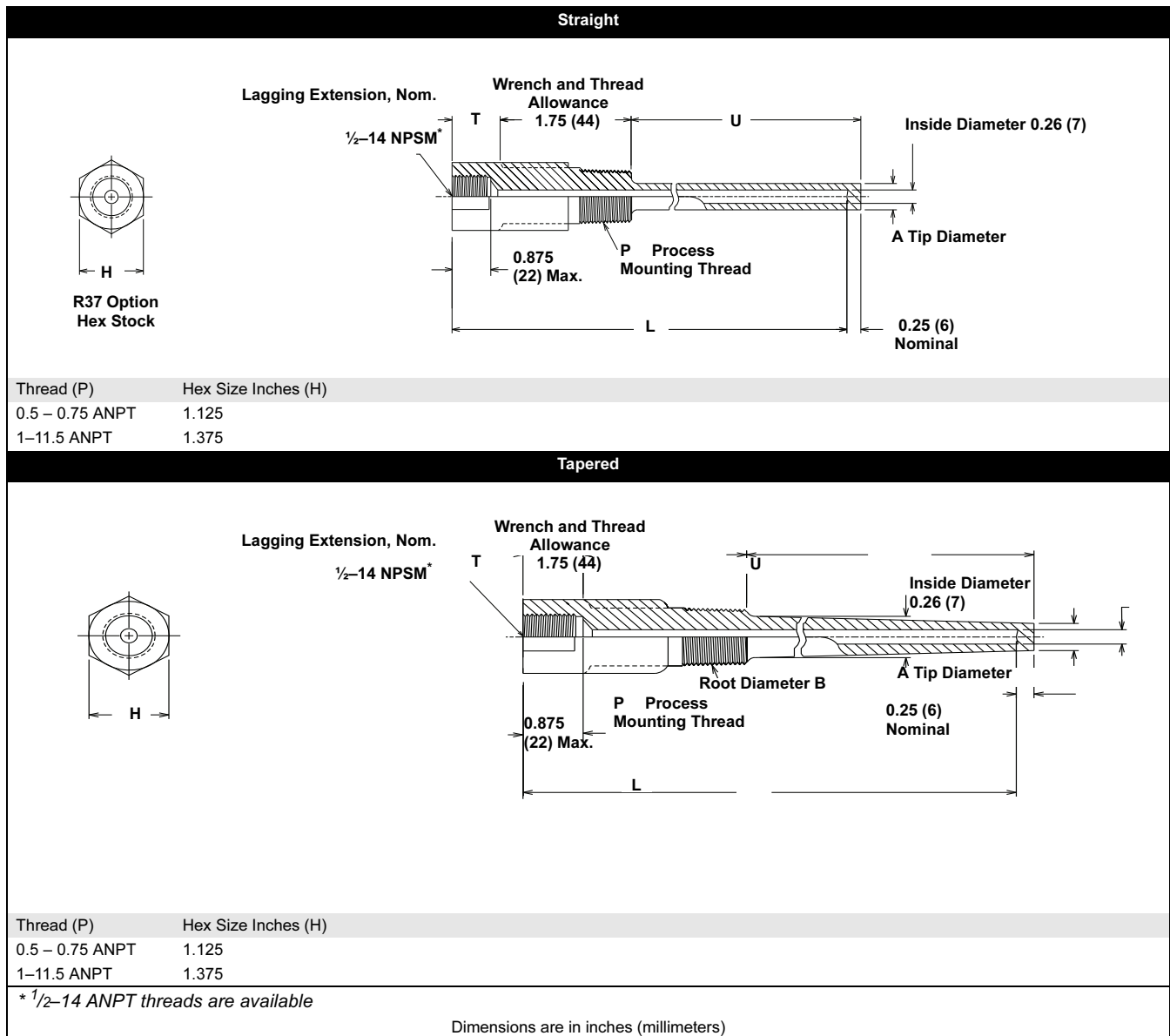

FIGURE 21. Thread Mounted Thermowells (continued)

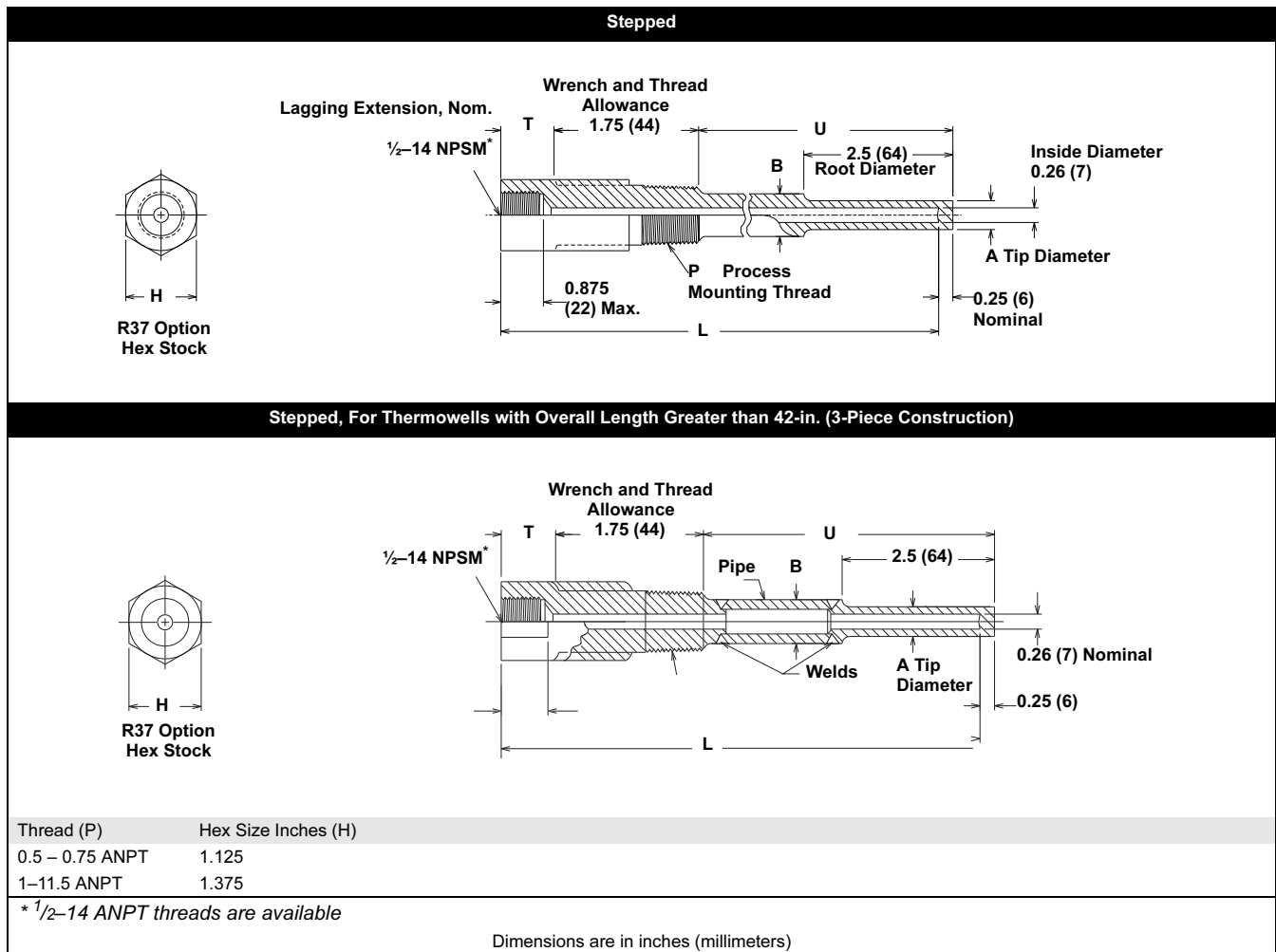

FIGURE 22. Weld Mounted Thermowells

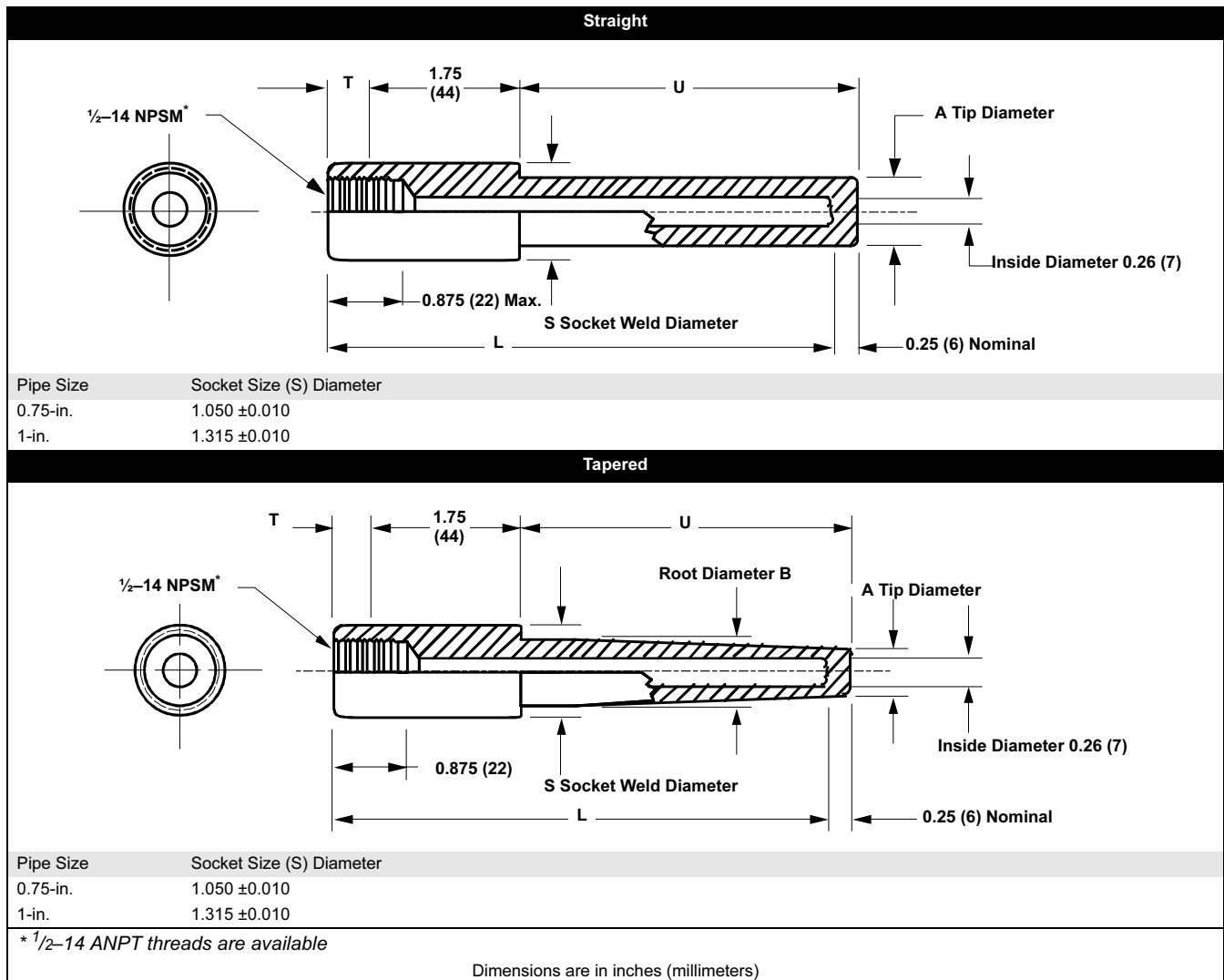

FIGURE 23. Weld Mounted Thermowells (continued)

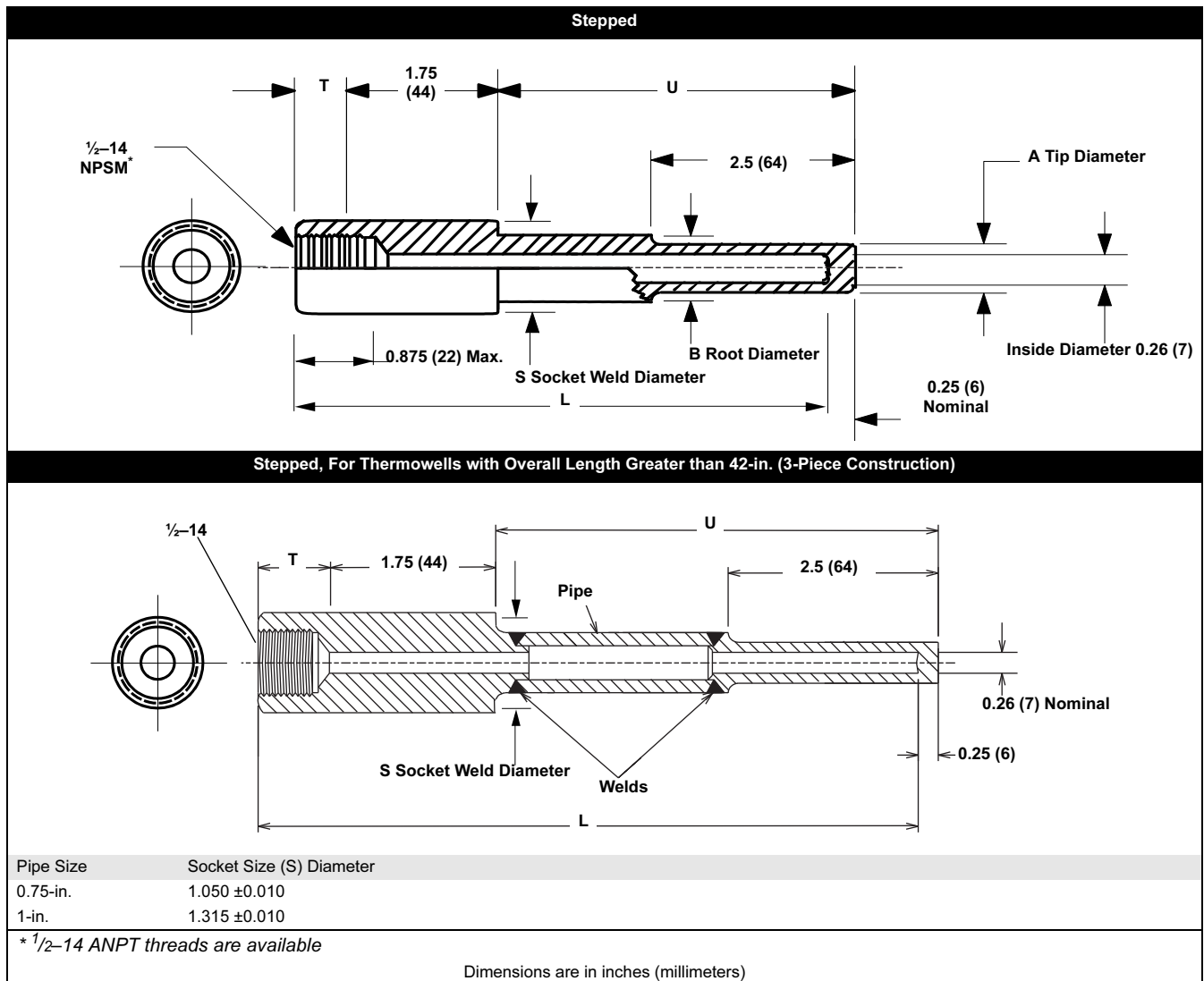

FIGURE 24. Flange Mounted Thermowells

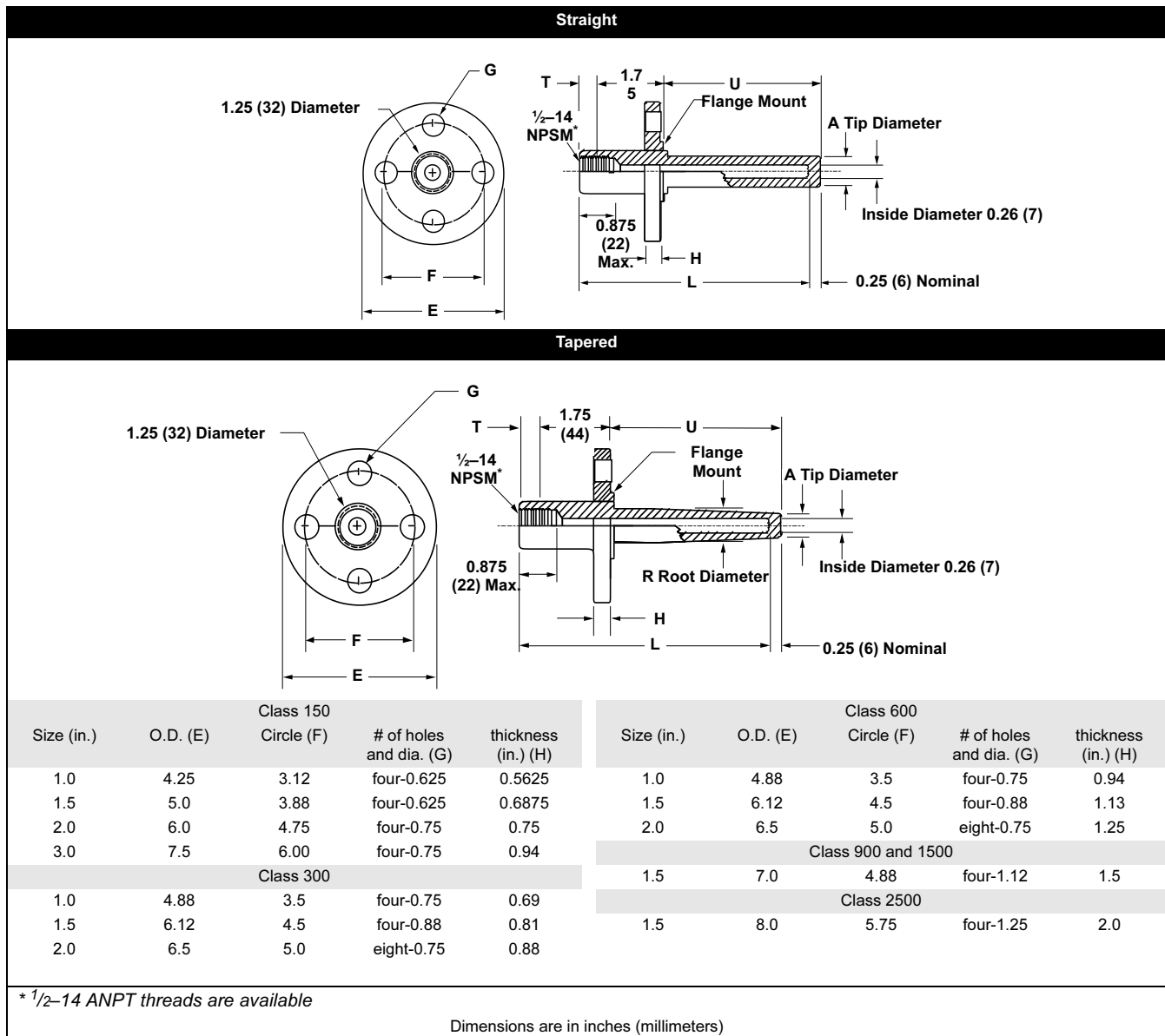
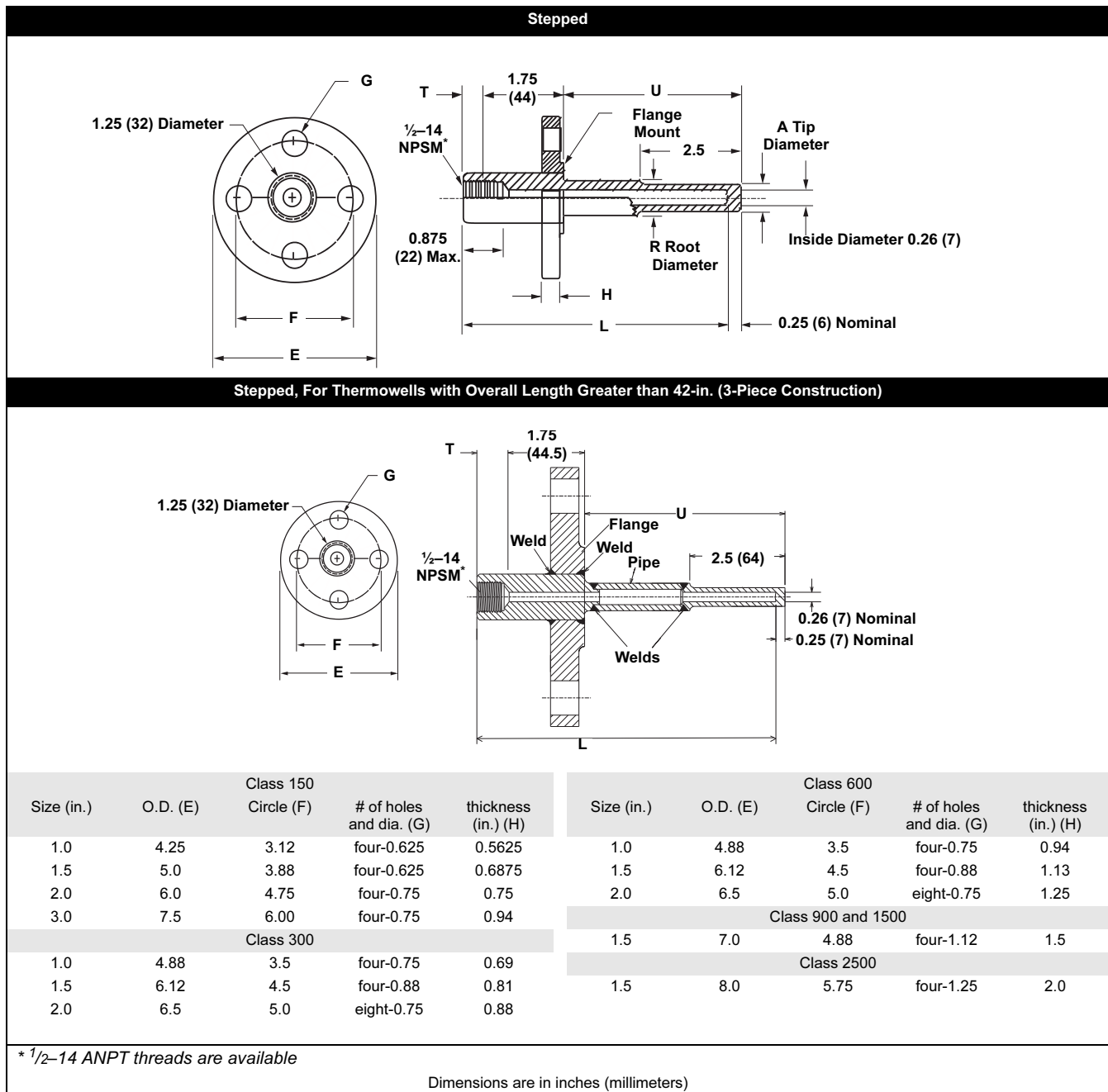

FIGURE 25. Flange Mounted Thermowells (continued)



# Sensors and Accessories (English)

## Hazardous Area Approvals

### SENSORS

#### Factory Mutual (FM) Approval

- E5** Explosion Proof for Class I, Division 1, Groups B, C, and D. Dust-Ignition Proof for Class II/III, Division 1, Groups E, F, and G. Suitable for indoor and outdoor (NEMA 4X) hazardous locations. Install in accordance with Rosemount drawing 00068-0013.

#### Canadian Standards Association (CSA) Approval

- E6** Explosion Proof for Class I, Division 1, Groups B, C, and D. Dust-Ignition Proof for Class II/III, Division 1, Groups E, F, and G. Suitable for Class I, Division 2, Groups A, B, C, and D. Suitable for indoor and outdoor (CSA Enclosure Type 4X) hazardous locations. Install in accordance with Rosemount drawing 00068-0033.

To ensure approval compliance install sensors in exact accordance with the specified installation drawings (see Figure 27).

### CONNECTION HEADS

#### Factory Mutual (FM) Approval

- E5** Explosion Proof for Class I, Division 1, Groups B, C, and D. Dust-Ignition Proof for Class II/III, Division 1, Groups E, F, and G. Painted models are suitable for indoor and outdoor (NEMA 4X) hazardous locations. Unpainted models are suitable for indoor and outdoor (NEMA 4) hazardous locations. When used with temperature sensors, connection heads must be installed in accordance with Rosemount drawing 00068-0013.

#### Canadian Standards Association (CSA) Approval

- E6** Explosion Proof for Class I, Division 1, Groups C, and D. Dust-Ignition Proof for Class II/III, Division 1, Groups E, F, and G. Suitable for Class I, Division 2, Groups A, B, C, and D. Painted models are suitable for indoor and outdoor (CSA Enclosure Type 4X) hazardous locations. Unpainted models are suitable for indoor and outdoor (CSA Enclosure Type 4) hazardous locations. When used with temperature sensors, connection heads must be installed in accordance with Rosemount drawing 00068-0033.

To ensure approval compliance, install connection heads in exact accordance with the specified installation drawings (see Figure 27).

### SENSOR AND TRANSMITTER ASSEMBLIES

#### ATEX Approval

- E1** ATEX Explosion- proof  
Certificate Number: KEMA99ATEX8715  
ATEX Marking:  II 2 G  
EEx d IIC T6 ( $-40^{\circ}\text{C} \leq T_{\text{amb}} \leq +65^{\circ}\text{C}$ )  
Rosemount Series 68 and 78 RTD and Series 183 thermocouple temperature sensors with spring-loaded or general purpose style sensors are approved only for direct mount to the Rosemount 3144P, 3244MV, 644, 244E, 144H, and 248 or mounted to the Rosemount Connection Head.  
To ensure approval compliance, specify the E1 option on both the sensor and the transmitter at the time of ordering.

#### NOTE

Rosemount series 68 and 78 RTD and Series 183 Thermocouple Temperature Sensors can be supplied as a replacement part with the E1 option for installation in an existing temperature measurement assembly.

#### Standard Association of Australia (SAA) Flameproof Approval

- E7** Ex d IIC T6 ( $T_{\text{amb}} = -20$  to  $60^{\circ}\text{C}$ )  
Rosemount Series 68 and 78 RTD and Series 183 thermocouple temperature sensors with spring-loaded or general purpose style sensor adapters are approved for direct mount to the Rosemount 144, 244E, 644, 3144 and 3244MV Smart Temperature Transmitters or mounted to the Rosemount Connection Head.  
To ensure approval compliance, specify the E7 option on both the sensor and the transmitter at the time of ordering, and install in exact accordance with Rosemount drawing 03144-0225 (see Figure 30).

**Factory Mutual (FM) Explosion-Proof**

FIGURE 26. Installation Drawing 00068-0013, Rev. AD

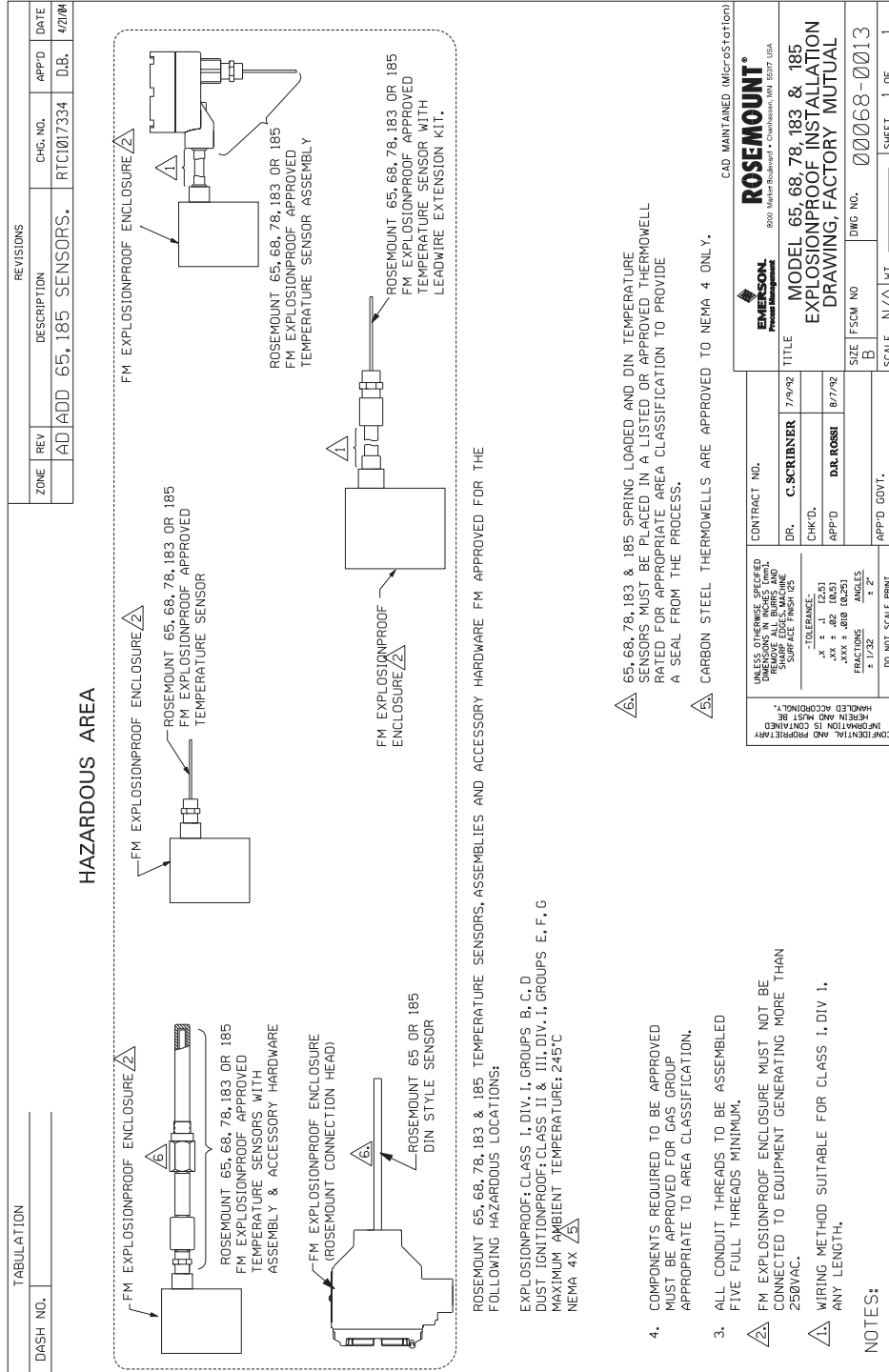

**NOTE**  
 For Hand-Tight Assembly Option XA: End-User (installer) must unscrew threaded joints, then reassemble and tighten all joints per installation drawing 00068-0013.

# Sensors and Accessories (English)

## Canadian Standards Association (CSA) Explosion-Proof

FIGURE 27. Installation Drawing 00068-0033, Rev. AB Page 1 of 2

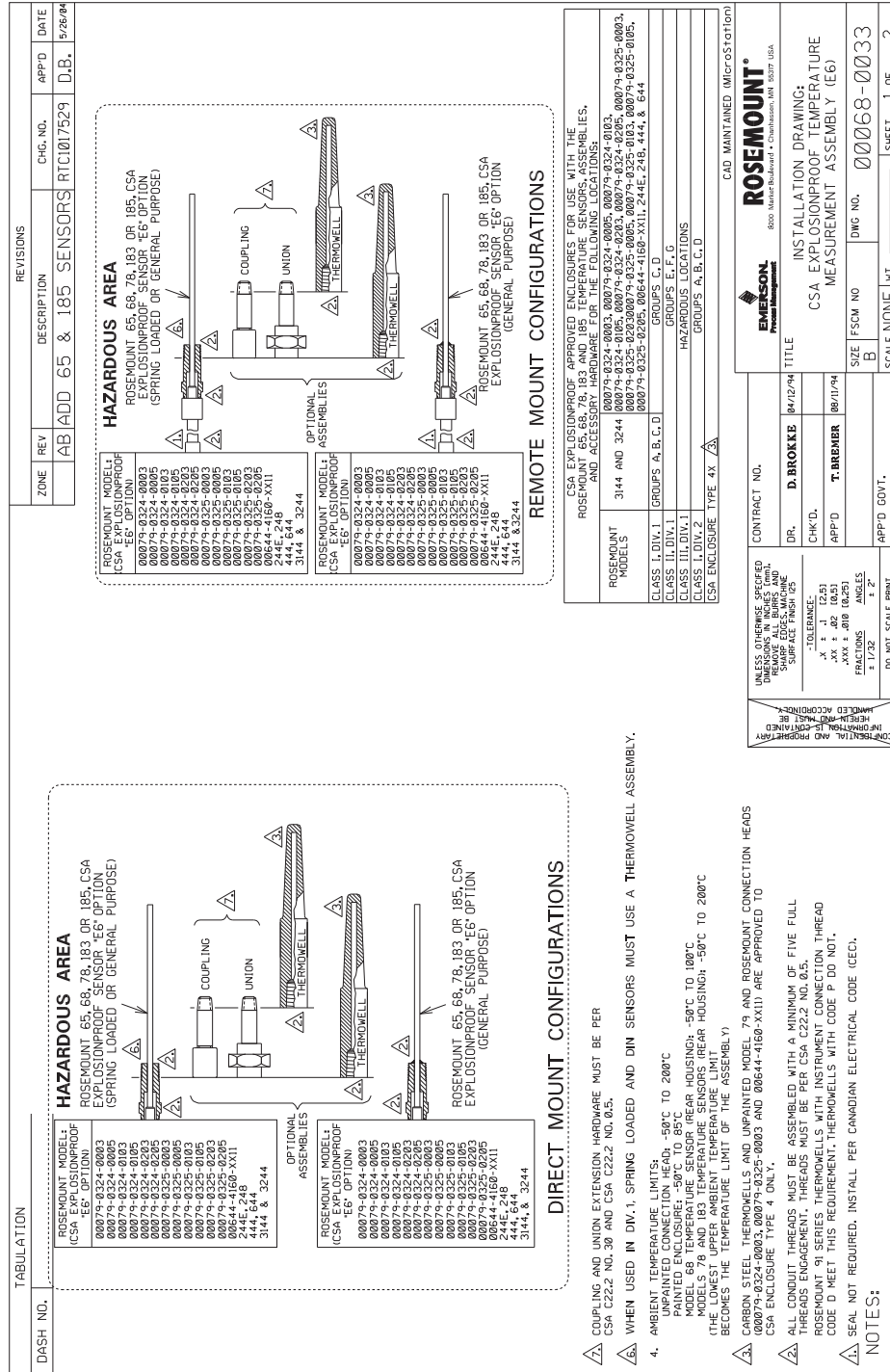

**NOTE**  
 For Hand-Tight Assembly Option XA: End-User (installer) must unscrew threaded joints, then reassemble and tighten all joints per installation drawing 00068-0033.

FIGURE 28. Installation Drawing 00068-0033, Rev. AB Page 2 of 2

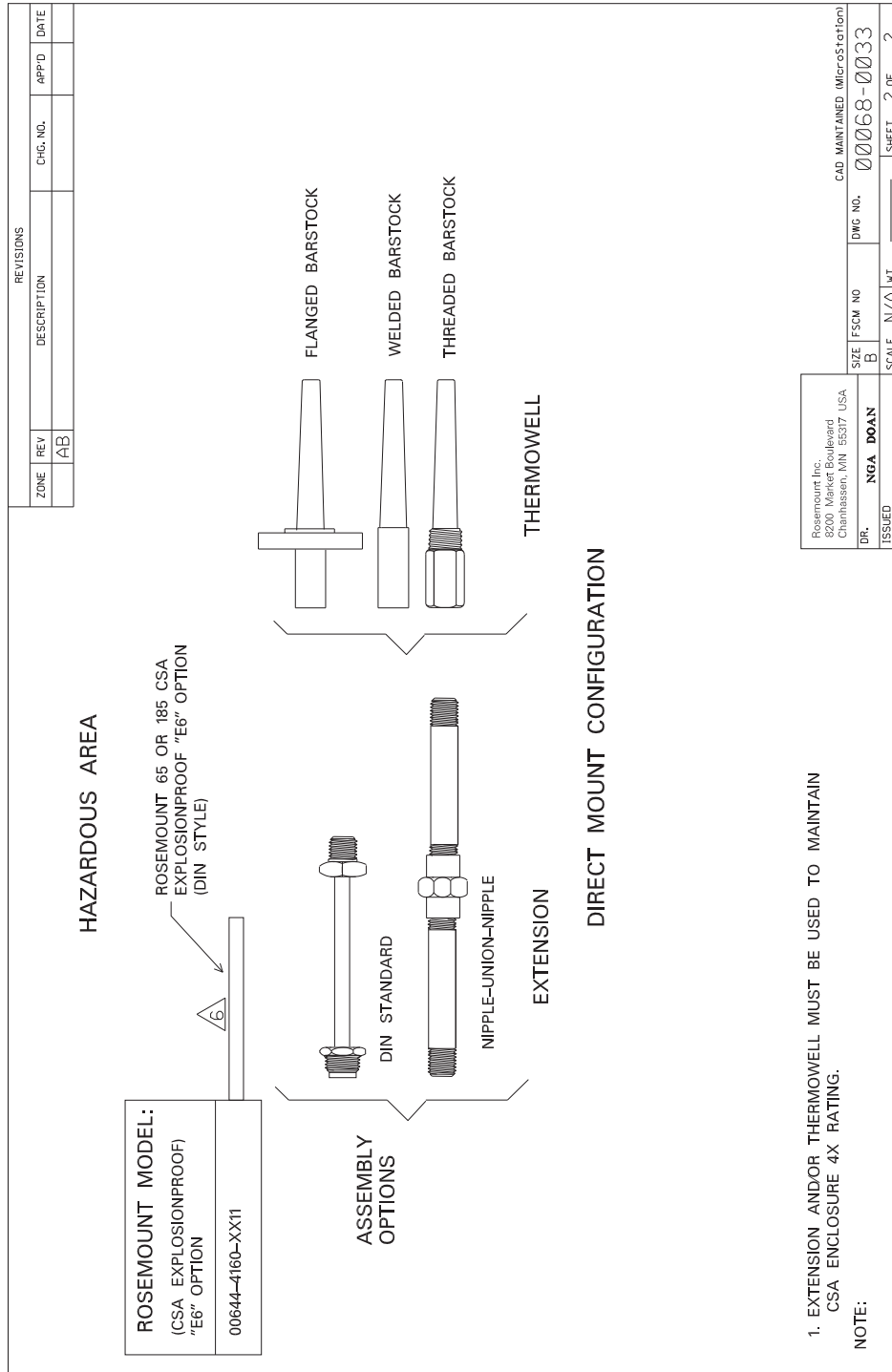

Rosemount Inc. 2200 Westgate Road Chanhassen, MN 55317 USA	DR. <b>NGA DOAN</b>	FSCM NO. <b>B</b>	DWG NO. <b>00068-0033</b>	CAD MAINTAINED (MicroStation)	SHEET <b>2</b> OF <b>2</b>
ISSUED	SCALE	N/A	WT.		

## ATEX Flameproof

FIGURE 29. Installation Drawing 03144-0324, Rev. AB

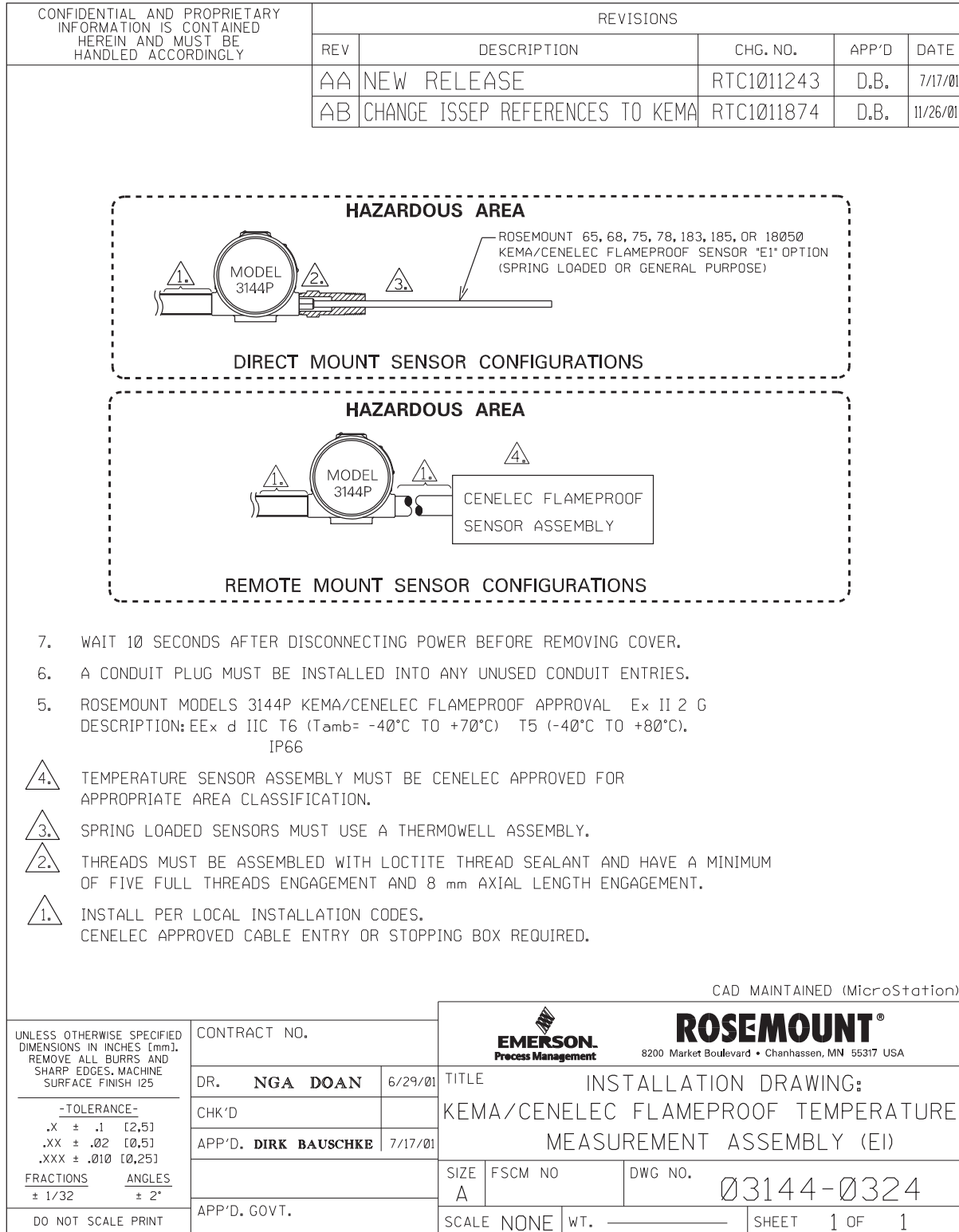

**Standard Association of Australia (SAA) Flameproof**

FIGURE 30. Drawing 03144-0325, Rev. AD

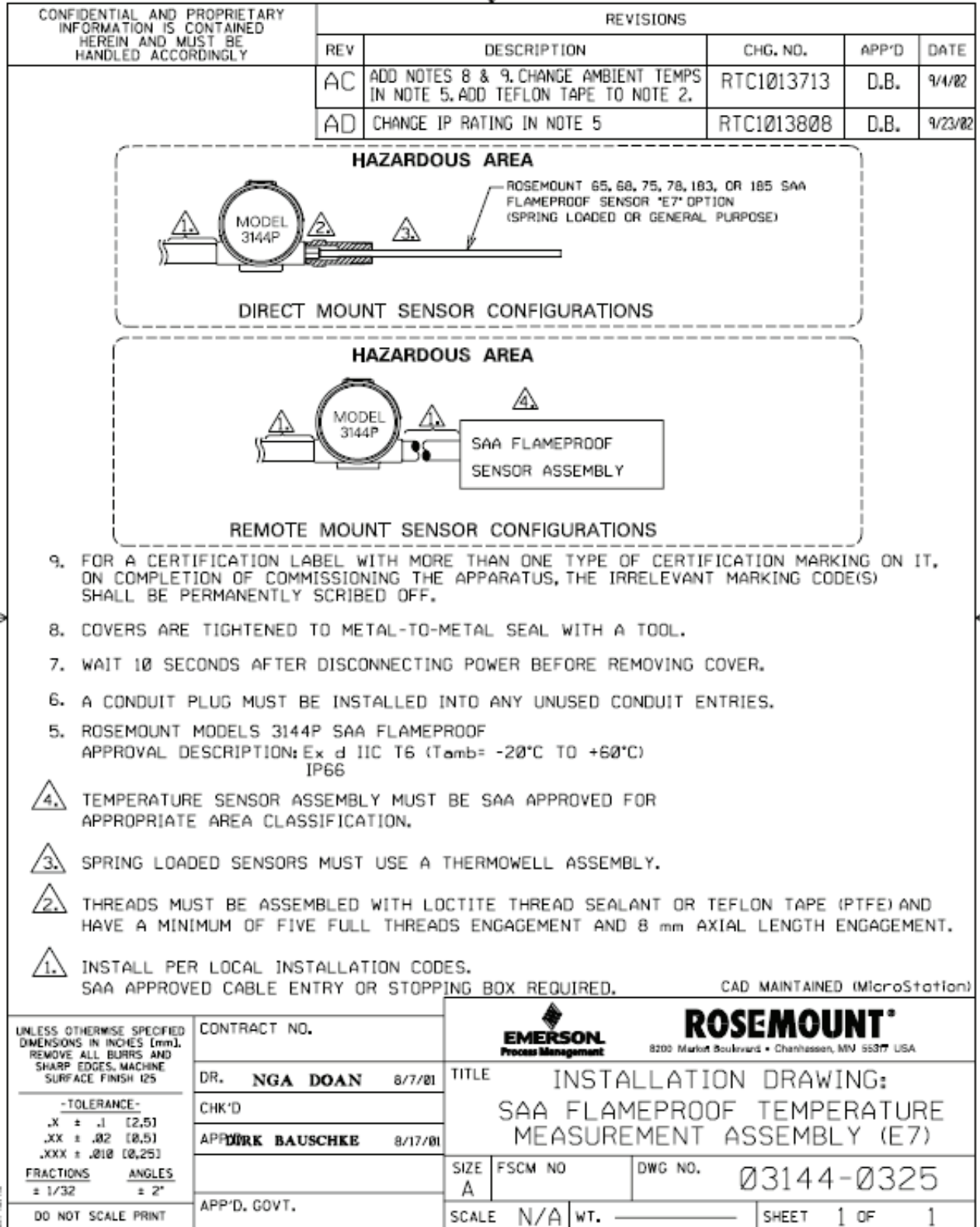

## Configuration Data Sheet

Calculations conducted per ASME/ANSI PTC 19.3 but with Strouhal number varying with Reynolds number.

### Company Information

Requesting Company: \_\_\_\_\_ Phone: \_\_\_\_\_ Fax: \_\_\_\_\_  
 Contact \_\_\_\_\_ Tag Number \_\_\_\_\_  
 End Customer \_\_\_\_\_ Date of Request: \_\_\_\_\_

### Thermowell Information (Information for either (a), (b), or (c) required)

- a) Rosemount Thermowell Part Number (example 0091A030FS2T040PR01):
- b) Rosemount Sensor Model Number (example 0078R21C30A120F54):
- c) Generic Thermowell Information:

Thermowell Material: \_\_\_\_\_

- Stem Style:  Straight  
 Stepped  
 Tapered

- Mounting Style:  Threaded  
 Welded  
 Flanged

- If flanged, specify:  ANSI/ASME  
 DIN

Size: \_\_\_\_\_ Class: \_\_\_\_\_

Thermowell Bore Diameter (D): \_\_\_\_\_

Tip Diameter (A): \_\_\_\_\_

Tip Thickness (T): \_\_\_\_\_

Length from Tip to Support (U): \_\_\_\_\_

Root Diameter (B): \_\_\_\_\_

(same as (A) for straight thermometers)

Length of Tip Diameter (Z): \_\_\_\_\_

(stepped thermowells only)

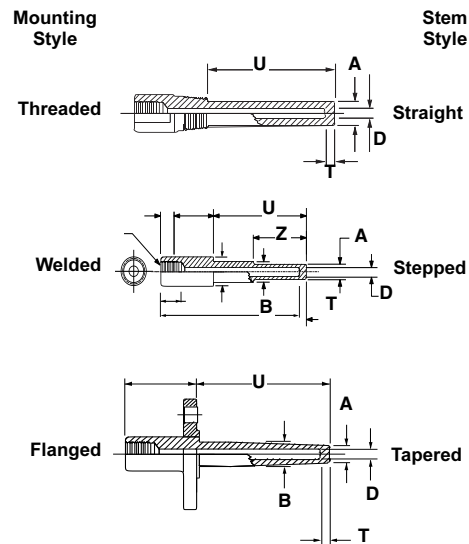

SENSORS\_0010B, 0016B, 0047B

Service:  Liquid  Gas  Steam Fluid Description: \_\_\_\_\_

Operating Fluid Flow Rate; Maximum: \_\_\_\_\_

Operating Fluid Flow Rate Units:

- gal/s  gal/min  gal/hr  l/s  l/min  l/hr  ft/s  
 ft<sup>3</sup>/min  ft<sup>3</sup>/hr  bbl/hr  impgal/s  impgal/min  impgal/hr  m/s  
 m<sup>3</sup>/min  m<sup>3</sup>/hr  shon/hr  lb/hr  kg/s  kg/hr  other:

Operating Max. Fluid Pressure: \_\_\_\_\_

- Gauge  
 Absolute

Viscosity:

- kg/m·s (Pa·s)  
 Centipoise

Operating Fluid Specific Temperature: \_\_\_\_\_

- °F  
 °C

Operating Fluid Density: \_\_\_\_\_

- m<sup>3</sup>/kg  
 ft<sup>3</sup>/lbm

Specific Volume: \_\_\_\_\_

- at process conditions  
 at standard conditions (STP)

Process Pipe Size: \_\_\_\_\_

Pipe Schedule: \_\_\_\_\_

### For Rosemount Internal Use Only

Rosemount Order/Quotation # \_\_\_\_\_ Line Item # \_\_\_\_\_ Ship Set # \_\_\_\_\_ ID # \_\_\_\_\_  
 Customer Order/Item # \_\_\_\_\_ Salesperson: \_\_\_\_\_  
 Cont. Admin. \_\_\_\_\_ Tech. Specialist: \_\_\_\_\_



# Sensors and Accessories (English)

---



## Product Data Sheet

00813-0100-2654, Rev GA

March 2008

# Sensors and Accessories (English)

---

*Rosemount and the Rosemount logotype are registered trademarks of Rosemount Inc.  
Teflon is a registered trademark of E.I. du Pont de Nemours & Co.  
Hastelloy is a registered trademark of Haynes International.  
Monel and Inconel is a registered trademark of International Nickel Co.  
All other marks are the property of their respective owners.*

*Standard Terms and Conditions of Sale can be found at [www.rosemount.com/terms\\_of\\_sale](http://www.rosemount.com/terms_of_sale)*

### Emerson Process Management

#### Rosemount Inc.

8200 Market Boulevard  
Chanhassen, MN 55317 USA  
T (U.S.) 1-800-999-9307  
T (International) (952) 906-8888  
F (952) 949-7001

[www.rosemount.com](http://www.rosemount.com)



#### Emerson Process Management

Heath Place  
Bognor Regis  
West Sussex PO22 9SH  
England  
T 44 (1243) 863 121  
F 44 (1243) 867 554

#### Emerson Process Management Asia

##### Pacific Private Limited

1 Pandan Crescent  
Singapore 128461  
T (65) 6777 8211  
F (65) 6777 0947  
Enquiries@AP.EmersonProcess.com



**EMERSON**  
Process Management