

BORINM/COMPRESSORE
M/COMPRESSORS
M/COMPRESSEURS
MOTORKOMPRESS**51VSM**

Model 51VSM		Displacement 949 cm ³ N° cylinders 2	Rotation looking from driving end Orario
Swept volume 1450 RPM 82,56 mc/h 1750 RPM 99,64 mc/h		Bore 88 Stroke 78 Oil charge 4 Kg.	Suction connection 42s Discharge connection 35s Net weight with flywheel 118 Kg
Max operating pressure BP 20 bar AP 25 bar		Sound power dBA ISO9614-1gr.2 Condit. 0 Refrig. 0	Operating speed range 600 RPM min. 1300 RPM max.
Driving motor power range 7,5-25 HP		Flywheel diameter External 335 mm Primit. 328 mm	Driving belts Nr 4 Type B
Type of lubrication A sbattimento		Type of oil with refrig. HCFC (CFC) Standard Suniso 3GS	Type of oil with refrig. HFC Opzionale POE 32
Std painting RAL5008	Gros weight 131 Kg.	Packing dimensions LxPxH 720x540x600 mm	Packing volume 0,233 m ³

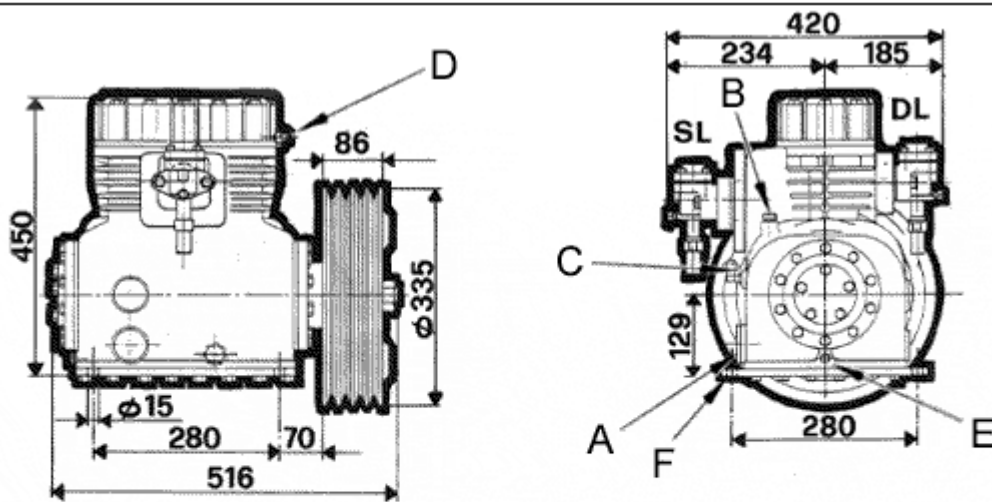

A	Spia Olio	Oil Sight	Voyant d'huile	Oelschauglas
B	Tappo carica Olio	Oil charge plug	Bouchon huile	Oelfuellschraube
C	Pres a Bassa Pres.	Low pressure tap	Prise basse pression	Anschluss Niederdruck
D	Pres a Alta Press.	High pressure tap	Prise haute pression	Anschluss Hochdruck
DL	Rubinetto Compressione	Discharge service valve	Vanne de refoulement	Druckabsperventil
SL	Rubinetto Aspirazione	Suction service valve	Vanne aspiration	Saugabsperventil
E	Tappo scarico olio	Oil drain plug	Bouchon de vid,d'huile	Oelablass Schraube
F	Resistenza carter	Crankcase heater	Resistance carter	Oelsumpfheizung

Available accessories

Description	Supply
CH=Crankcase Heater	Option
BF=Body cooling fan	Option
WH=Water cooled head	Option
US=By-pass system	Option
OL=Oil level float valve	Option
PDD=Double pressure switch	Option
OS=Oil separator	Option
LS=Liquid separator	Option