



**Allen-Bradley**

## ControlLogix Digital I/O Modules

### Input Modules

1756-IA16, -IA16I, -IA8D, -IB16,  
-IB16D, -IB16I, -IB32, -IC16, -IH16I,  
-IM16I, -IN16, -IV16, -IV32

### Output Modules

1756-OA16, -OA16I, -OA8, -OA8D,  
-OA8E, -OB16D, -OB16E, -OB16I,  
-OB32, -OB8, -OB8EI, -OC8, -OH8I,  
-ON8, -OV16E, -OW16I, -OX8I

User Manual

**Rockwell  
Automation**

## Important User Information

Because of the variety of uses for the products described in this publication, those responsible for the application and use of this control equipment must satisfy themselves that all necessary steps have been taken to assure that each application and use meets all performance and safety requirements, including any applicable laws, regulations, codes and standards.

The illustrations, charts, sample programs and layout examples shown in this guide are intended solely for purposes of example. Since there are many variables and requirements associated with any particular installation, Allen-Bradley does not assume responsibility or liability (to include intellectual property liability) for actual use based upon the examples shown in this publication.

Allen-Bradley publication SGI-1.1, *Safety Guidelines for the Application, Installation and Maintenance of Solid-State Control* (available from your local Allen-Bradley office), describes some important differences between solid-state equipment and electromechanical devices that should be taken into consideration when applying products such as those described in this publication.

Reproduction of the contents of this copyrighted publication, in whole or part, without written permission of Rockwell Automation, is prohibited.

Throughout this manual we use notes to make you aware of safety considerations:

---

### ATTENTION



Identifies information about practices or circumstances that can lead to personal injury or death, property damage or economic loss

---

Attention statements help you to:

- identify a hazard
- avoid a hazard
- recognize the consequences

---

### IMPORTANT

Identifies information that is critical for successful application and understanding of the product.

---

## European Communities (EC) Directive Compliance

If this product has the CE mark it is approved for installation within the European Union and EEA regions. It has been designed and tested to meet the following directives.

### EMC Directive

This product is tested to meet the Council Directive 89/336/EC Electromagnetic Compatibility (EMC) by applying the following standards, in whole or in part, documented in a technical construction file:

- EN 50081-2 EMC — Generic Emission Standard, Part 2 — Industrial Environment
- EN 50082-2 EMC — Generic Immunity Standard, Part 2 — Industrial Environment

This product is intended for use in an industrial environment.

### Low Voltage Directive

This product is tested to meet Council Directive 73/23/EEC Low Voltage, by applying the safety requirements of EN 61131-2 Programmable Controllers, Part 2 - Equipment Requirements and Tests. For specific information required by EN 61131-2, see the appropriate sections in this publication, as well as the Allen-Bradley publication Industrial Automation Wiring and Grounding Guidelines For Noise Immunity, publication 1770-4.1.

Open style devices must be provided with environmental and safety protection by proper mounting in enclosures designed for specific application conditions. See NEMA Standards publication 250 and IEC publication 529, as applicable, for explanations of the degrees of protection provided by different types of enclosure.

## **Rockwell Automation Support**

Rockwell Automation offers support services worldwide, with over 75 sales/support offices, 512 authorized distributors and 260 authorized systems integrators located throughout the United States alone, as well as Rockwell Automation representatives in every major country in the world.

### **Local Product Support**

Contact your local Rockwell Automation representative for:

- sales and order support
- product technical training
- warranty support
- support service agreements

### **Technical Product Assistance**

If you need to contact Rockwell Automation for technical assistance, please review the troubleshooting information first. If the problem persists, then call your local Rockwell Automation representative.

### **Your Questions or Comments on this Manual**

If you find a problem with this manual, please notify us of it on the enclosed Publication Problem Report.

### Introduction

This release of this document contains updated information. Changes are designated by change bars in margin, as shown to the left.

### New and Revised Information

The table below lists the new and revised information included in this release of the ControlLogix digital I/O modules user manual.

**Table Summary of Changes.1**  
**New and Revised Information**

<b>Information About</b>	<b>New or Revised</b>	<b>Location</b>
Internal Module Operations	New	Chapter 2
Connections	Revised	Chapter 2
Electronic Keying	Revised	Chapter 3 Chapter 4
Output Data Echo	Revised	Chapter 3 Chapter 4
1756-IV16 Module	New	Chapter 3 Chapter 7
1756-IV32 Module	New	Chapter 3 Chapter 7
1756-OV16E Module	New	Chapter 3 Chapter 7
Additional Index Terms	Revised and New	Index

**Notes:**

## About This User Manual

**What This Preface Contains** This preface describes how to use this manual. The following table describes what this preface contains and its location.

For information about:	See page:
Who Should Use This Manual	Preface-1
Purpose of This Manual	Preface-1
Related Terms	Preface-2
Related Products and Documentation	Preface-4

### Who Should Use This Manual

You must be able to program and operate an Allen-Bradley ControlLogix™ Logix5550 controller to efficiently use your digital I/O modules.

We assume that you know how to do this in this manual. If you do not, refer to the Logix5550 Controller documentation before you attempt to use this module. Table C lists related documentation.

### Purpose of This Manual

This manual describes how to install, configure, and troubleshoot your ControlLogix digital I/O module.

## Related Terms

This manual uses the following terms:

**Table Preface.B**  
**Related Terms**

<b>This term:</b>	<b>Means:</b>
Broadcast	Data transmissions to all address or functions
Bumpless reconfiguration	A reconfiguration in which the real time data connection to the module is not closed and reopened. Communications are never interrupted and configuration data is applied to the module immediately. This works best in a single owner-controller system.
Change of state (COS)	Any change in the ON or OFF state of a point on an I/O module
Communications format	Format that defines the type of information transferred between an I/O module and its owner controller. This format also defines the tags created for each I/O module.
Compatible match	An electronic keying protection mode that requires that the physical module and the module configured in the software to match according to vendor and catalog number. In this case, the minor revision of the module must greater than or equal to that of the configured slot.
Connection	The communication mechanism from the controller to another module in the control system
ControlBus	The backplane used by the 1756 chassis
Coordinated system time (CST)	Timer value which is kept synchronized for all modules within a single ControlBus chassis
Direct connection	An I/O connection where the controller establishes an individual connection with I/O modules
Disable keying	An electronic keying protection mode that requires no attributes of the physical module and the module configured in the software to match
Download	The process of transferring the contents of a project on the workstation into the controller
Electronic keying	A feature where modules can be requested to perform an electronic check to make sure that the physical module is consistent with what was configured by the software
Exact match	An electronic keying protection mode that requires the physical module and the module configured in the software to match according to vendor, catalog number, major revision and minor revision
Field side	Interface between user field wiring and I/O module
Inhibit	A ControlLogix process that allows you to configure an I/O module but prevent it from communicating with the owner controller. In this case, the controller behaves as if the I/O module does not exist at all
Interface module (IFM)	A module that uses prewired cable to connect wiring to an I/O module
Listen-only connection	An I/O connection where another controller owns/provides the configuration and data for the module

**Table Preface.B**  
**Related Terms**

Major revision	A module revision that is updated any time there is a functional change to the module
Minor revision	A module revision that is updated any time there is a change to the module that does not affect its function or interface
Multicast	Data transmissions which reach a specific group of one or more destinations
Multiple owners	A configuration set-up where multiple owner controllers use exactly the same configuration information to simultaneously own an input module
Network update time (NUT)	The smallest repetitive time interval in which the data can be sent on a ControlNet network. The NUT ranges from 2ms to 100ms
Owner controller	The controller that creates and stores the primary configuration and communication connection to a module
Program Mode	Controller program is not executing. Inputs are still actively producing data. Outputs are not actively controlled and go to their configured program mode
Rack connection	An I/O connection where the 1756-CNB module collects digital I/O words into a rack image to conserve ControlNet connections and bandwidth
Rack optimization	A communications format in which the 1756-CNB module collects all digital I/O words in the remote chassis and sends them to controller as a single rack image
Remote connection	An I/O connection where the controller establishes an individual connection with I/O modules in a remote chassis
Removal and insertion under power (RIUP)	ControlLogix feature that allows a user to install or remove a module or RTB while power is applied
Removable Terminal Block (RTB)	Field wiring connector for I/O modules
Requested packet interval (RPI)	The maximum amount of time between broadcasts of I/O data
Run mode	Controller program is executing Inputs are actively producing data. Outputs are actively controlled
Service	A system feature that is performed on user demand, such as fuse reset or diagnostic latch reset
System side	Backplane side of the interface to the I/O module
Tag	A named area of the controller's memory where data is stored
Timestamping	ControlLogix process that stamps a change in input data with a relative time reference of when that change occurred

## Related Products and Documentation

The following table lists related ControlLogix products and documentation:

**Table Preface.C**  
**Related Documentation**

<b>Catalog number:</b>	<b>Document title:</b>	<b>Pub. number:</b>
1756-A4, -A7, -A10, -A13	ControlLogix Chassis Installation Instructions	1756-IN080B
1756-PA72, -PB72	ControlLogix Power Supply Installation Instructions	1756-5.67
1756-PA75, -PB75	ControlLogix Power Supply Installation Instructions	1756-5.78
1756-Series	ControlLogix Module Installation Instructions (Each module has separate installation document.)	Multiple 1756-IN numbers
1756-Series	ControlLogix System User Manual	1756-UM001
1756-Series	ControlLogix Analog I/O Modules User Manual	1756-6.5.9
1756-CNB, -CNBR	ControlLogix ControlNet Interface Module User Manual	1756-6.5.3
1756-DHRIO	ControlLogix Data Highway Plus Communication Interface Module User Manual	1756-6.5.14
1756-ENET	ControlLogix Ethernet Communication Interface Module User Manual	1756-UM051

If you need more information on these products, contact your local Allen-Bradley integrator or sales office for assistance. For more information on the documentation, refer to the Allen-Bradley Publication Index, publication SD499.

	<b>Chapter 1</b>	
<b>What Are ControlLogix Digital I/O Modules?</b>	What This Chapter Contains . . . . .	1-1
	What are ControlLogix Digital I/O Modules? . . . . .	1-1
	Using an I/O Module in the ControlLogix System . . . . .	1-2
	Features of the ControlLogix Digital I/O Modules . . . . .	1-4
	Using Module Identification and Status Information . . . . .	1-5
	Preventing Electrostatic Discharge . . . . .	1-6
	Removal and Insertion Under Power . . . . .	1-6
	Chapter Summary and What's Next . . . . .	1-6
	<b>Chapter 2</b>	
<b>Digital I/O Operation in the ControlLogix System</b>	What This Chapter Contains . . . . .	2-1
	Ownership . . . . .	2-2
	Using RSNetWorx and RSLogix 5000 . . . . .	2-2
	I/O Modules in Local Chassis . . . . .	2-2
	I/O Modules in Remote Chassis . . . . .	2-3
	Internal Module Operations. . . . .	2-4
	Input Modules . . . . .	2-4
	Output Modules. . . . .	2-5
	Connections . . . . .	2-6
	Direct Connections . . . . .	2-6
	Rack Connections . . . . .	2-7
	Suggestions for Rack Connection Usage . . . . .	2-8
	Input Module Operation . . . . .	2-9
	Input Modules in a Local Chassis. . . . .	2-10
	Requested Packet Interval (RPI) . . . . .	2-10
	Change of State (COS) . . . . .	2-10
	Input Modules in a Remote Chassis . . . . .	2-11
	Best Case RPI Multicast Scenario. . . . .	2-12
	Worst Case RPI Multicast Scenario . . . . .	2-13
	Output Module Operation . . . . .	2-14
	Output Modules in a Local Chassis . . . . .	2-14
	Output Modules in a Remote Chassis. . . . .	2-15
	Best Case RPI Multicast Scenario. . . . .	2-16
	Worst Case RPI Multicast Scenario . . . . .	2-16
	Listen-Only Mode . . . . .	2-17
	Multiple Owners of Input Modules . . . . .	2-18
	Configuration Changes in an Input Module with Multiple Owners . . . . .	2-19
	Chapter Summary and What's Next . . . . .	2-20

	<b>Chapter 3</b>	
<b>ControlLogix Standard Digital I/O Module Features</b>	What This Chapter Contains . . . . .	3-1
	Determining Input Module Compatibility . . . . .	3-1
	Determining Output Module Compatibility. . . . .	3-2
	Using Features Common to ControlLogix Standard Digital I/O Modules . . . . .	3-3
	Removal and Insertion Under Power (RIUP) . . . . .	3-3
	Module Fault Reporting . . . . .	3-3
	Fully Software Configurable . . . . .	3-3
	Electronic Keying. . . . .	3-4
	Using the System Clock to Timestamp Inputs and Schedule Outputs . . . . .	3-7
	Producer/Consumer Model. . . . .	3-9
	LED Status Information. . . . .	3-10
	Full Class I Division 2 Compliance . . . . .	3-10
	CE/CSA/UL/FM Agency Approvals . . . . .	3-11
	Using Features Specific to Standard Input Modules. . . . .	3-11
	Data Transfer on Either Change of State or Cyclic Time. . . . .	3-11
	Software Configurable Filter Times . . . . .	3-11
	Isolated and Non-Isolated Varieties of Modules. . . . .	3-12
	Multiple Point Densities . . . . .	3-12
	Using Features Specific to Standard Output Modules . . . . .	3-12
	Configurable Point-Level Output Fault States. . . . .	3-12
	Output Data Echo . . . . .	3-13
Field Wiring Options . . . . .	3-14	
Multiple Point Densities . . . . .	3-14	
Fusing. . . . .	3-14	
Field Power Loss Detection . . . . .	3-17	
Diagnostic Latch of Information . . . . .	3-17	
Fault and Status Reporting Between Input Modules and Controllers. . . . .	3-18	
Fault and Status Reporting Between Output Modules and Controller . . . . .	3-19	
Chapter Summary and What's Next . . . . .	3-21	
	<b>Chapter 4</b>	
<b>ControlLogix Diagnostic Digital I/O Module Features</b>	What This Chapter Contains . . . . .	4-1
	Determining Diagnostic Input Module Compatibility. . . . .	4-1
	Determining Diagnostic Output Module Compatibility . . . . .	4-2
	Using Features Common to ControlLogix Diagnostic Digital I/O Modules . . . . .	4-3
	Removal and Insertion Under Power (RIUP) . . . . .	4-3
	Module Fault Reporting . . . . .	4-3
	Fully Software Configurable . . . . .	4-3
	Electronic Keying. . . . .	4-4

Timestamping Inputs and Scheduling Outputs. . . . .	4-7
Producer/Consumer Model. . . . .	4-9
LED Status Information. . . . .	4-10
Full Class I Division 2 Compliance . . . . .	4-10
CE/CSA/UL/FM Agency Approvals . . . . .	4-11
Diagnostic Latch of Information . . . . .	4-11
Diagnostic Timestamp . . . . .	4-11
8 Point AC/16 Point DC . . . . .	4-12
Point Level Fault Reporting . . . . .	4-12
Using Features Specific to Diagnostic Input Modules . . . . .	4-14
Data Transfer on Either Change of State or Cyclic Time. . . . .	4-14
Software Configurable Filter Times . . . . .	4-14
Isolated and Non-Isolated Varieties of Modules. . . . .	4-14
Multiple Point Densities . . . . .	4-15
Open Wire Detection. . . . .	4-15
Field Power Loss Detection . . . . .	4-16
Diagnostic Change of State for Input Modules. . . . .	4-16
Using Features Specific to Diagnostic Output Modules . . . . .	4-17
Configurable Point-Level Output Fault States. . . . .	4-17
Output Data Echo . . . . .	4-18
Field Wiring Options . . . . .	4-19
Multiple Point Densities . . . . .	4-19
Fusing. . . . .	4-20
No Load Detection. . . . .	4-21
Field Side Output Verification. . . . .	4-22
Pulse Test . . . . .	4-22
Point Level Electronic Fusing . . . . .	4-24
Field Power Loss Detection. . . . .	4-24
Diagnostic Change of State for Output Modules . . . . .	4-25
Fault and Status Reporting Between Input Modules and Controllers . . . . .	4-25
Fault and Status Reporting Between Output Modules and Controller . . . . .	4-27
Chapter Summary and What's Next . . . . .	4-29

## Chapter 5

### Installing the ControlLogix I/O Module

What This Chapter Contains . . . . .	5-1
Installing the ControlLogix I/O Module . . . . .	5-1
Keying the Removable Terminal Block. . . . .	5-2
Connecting Wiring . . . . .	5-4
Assembling Removable Terminal Block and the Housing . . . . .	5-7
Choosing the Extended-Depth Housing . . . . .	5-8
Installing the Removable Terminal Block . . . . .	5-10
Removing the Removable Terminal Block . . . . .	5-12
Removing the Module from the Chassis . . . . .	5-13
Chapter Summary and What's Next . . . . .	5-14

---

	<b>Chapter 6</b>	
<b>Configuring Your ControlLogix Digital I/O Modules</b>	What This Chapter Contains . . . . .	6-1
	Configuring Your I/O Module . . . . .	6-2
	RSLogix 5000 Configuration Software . . . . .	6-2
	Overview of the Configuration Process . . . . .	6-2
	Creating a New Module. . . . .	6-4
	Communications Format. . . . .	6-6
	Electronic Keying. . . . .	6-9
	Using the Default Configuration. . . . .	6-10
	Altering the Default Configuration . . . . .	6-10
	Configuring a Standard Input Module . . . . .	6-12
	Configuring a Standard Output Module . . . . .	6-13
	Configuring a Diagnostic Input Module . . . . .	6-14
	Configuring a Diagnostic Output Module . . . . .	6-15
	Editing Configuration . . . . .	6-16
	Reconfiguring Module Parameters in Remote Run Mode . . . . .	6-17
	Reconfiguring Module Parameters in Program Mode. . . . .	6-18
	Configuring I/O Modules in a Remote Chassis . . . . .	6-19
	Input Online Services . . . . .	6-21
	Output Online Services . . . . .	6-22
	Viewing and Changing Module Tags . . . . .	6-23
Chapter Summary and What's Next . . . . .	6-24	
	<b>Chapter 7</b>	
<b>Module-Specific Information</b>	What This Chapter Contains . . . . .	7-1
	1756-IA16 . . . . .	7-2
	1756-IA16I . . . . .	7-4
	1756-IA8D . . . . .	7-6
	1756-IB16 . . . . .	7-8
	1756-IB16D. . . . .	7-10
	1756-IB16I . . . . .	7-12
	1756-IB32 . . . . .	7-14
	1756-IC16 . . . . .	7-16
	1756-IH16I . . . . .	7-18
	1756-IM16I . . . . .	7-20
	1756-IN16 . . . . .	7-22
	1756-IV16 . . . . .	7-24
	1756-IV32 . . . . .	7-26
	1756-OA16 . . . . .	7-28
	1756-OA16I. . . . .	7-30
	1756-OA8 . . . . .	7-32
	1756-OA8D. . . . .	7-34
	1756-OA8E . . . . .	7-36
	1756-OB16D. . . . .	7-38
1756-OB16E . . . . .	7-40	

	1756-OB16I . . . . .	7-42
	1756-OB32 . . . . .	7-44
	1756-OB8 . . . . .	7-46
	1756-OB8EI . . . . .	7-48
	1756-OC8 . . . . .	7-50
	1756-OH8I . . . . .	7-52
	1756-ON8 . . . . .	7-54
	1756-OV16E . . . . .	7-56
	1756-OW16I . . . . .	7-58
	1756-OX8I . . . . .	7-60
	Chapter Summary and What's Next . . . . .	7-62
	<b>Chapter 8</b>	
<b>Troubleshooting Your Module</b>	What This Chapter Contains . . . . .	8-1
	Using Indicators to Troubleshoot Your Module . . . . .	8-1
	LED indicators for input modules . . . . .	8-1
	LED indicators for output modules . . . . .	8-2
	Using RSLogix 5000 to Troubleshoot Your Module . . . . .	8-4
	Determining Fault Type . . . . .	8-5
	Chapter Summary and What's Next . . . . .	8-6
	<b>Appendix A</b>	
<b>Using Software Configuration Tags</b>	Module Tag Names and Definitions . . . . .	A-3
	Standard Input Module Tags . . . . .	A-3
	Standard Output Module Tags . . . . .	A-4
	Diagnostic Input Module Tags . . . . .	A-6
	Diagnostic Output Module Tags . . . . .	A-8
	Accessing the Tags . . . . .	A-11
	Changing Configuration Through the Tags . . . . .	A-12
	Module-wide Configurable Features . . . . .	A-12
	Point-by-Point Configurable Features . . . . .	A-13
	Downloading New Configuration Data	
	From the Tag Editor . . . . .	A-14
	Sample Series of Tags . . . . .	A-15
	<b>Appendix B</b>	
<b>Using Ladder Logic</b>	Using Message Instructions . . . . .	B-1
	Processing Real-Time Control and Module Services . . . . .	B-2
	One Service Performed Per Instruction . . . . .	B-2
	Creating a New Tag . . . . .	B-3
	Enter Message Configuration . . . . .	B-4
	Using Timestamped Inputs and Scheduled Outputs . . . . .	B-10
	Resetting a Fuse, Performing the Pulse Test and Resetting Latched Diagnostics . . . . .	B-13

Performing a WHO to Retrieve Module Identification  
and Status . . . . . B-14  
Using Tags in Ladder Logic . . . . . B-16

**Appendix C**

**Power Supply Sizing Chart**

**Appendix D**

**Driving Motor Starters with  
ControlLogix Digital I/O Modules**

Determining the Maximum Number of Motor Starters . . D-2

**Index**

## What Are ControlLogix Digital I/O Modules?

**What This Chapter Contains** This chapter describes the ControlLogix digital modules and what you must know and do before you begin to use them.

For information about:	See page:
What are ControlLogix Digital I/O Modules?	1-1
Using an I/O Module in the ControlLogix System	1-2
Types of ControlLogix Digital I/O Modules	1-2
Features of the ControlLogix Digital I/O Modules	1-4
Preventing Electrostatic Discharge	1-6
Removal and Insertion Under Power	1-6
Chapter Summary and What's Next	1-6

### What are ControlLogix Digital I/O Modules?

ControlLogix digital I/O modules are input/output modules that provide ON/OFF detection and actuation.

Using the producer/consumer network model, they can produce information when needed while providing additional system functions.

The following is a list of the features available on ControlLogix digital I/O modules that allow greater system applicability.

- Removal and insertion under power (RIUP) - This system feature allows you to remove and insert modules and RTB while power is applied. For more information on RIUP, see page 1-6.
- Producer/consumer communications - These communications are an intelligent data exchange between modules and other system devices in which each module produces data without having been polled.
- System timestamp of data - A 64-bit system clock places a timestamp on the transfer of data between the module and its owner-controller within the local chassis.
- Module level fault reporting and field side diagnostic detection
- Class I Division 2, UL, CSA, FM and CE Agency Certification

## Using an I/O Module in the ControlLogix System

ControlLogix modules mount in a ControlLogix chassis and use a Removable Terminal Block (RTB) or a Bulletin 1492 Interface Module cable that connects to an IFM to connect all field-side wiring.

Before you install and use your module you should have already:

- installed and grounded a 1756 chassis and power supply. To install these products, refer to the publications listed in Table 1.A.

**Table 1.A**  
**Chassis and Power Supply Documentation**

Catalog number:	Document title:	Pub. number:
1756-A4, -A7, -A10, -A13	ControlLogix Chassis Installation Instructions	1756-IN080B
1756-PA72, -PB72	ControlLogix Power Supply Installation Instructions	1756-5.67
1756-PA75, -PB75	ControlLogix Power Supply Installation Instructions	1756-5.78

- ordered and received an RTB or IFM and its components for your application.

### IMPORTANT

RTBs and IFMs are not included with your module purchase.

**Table 1.B**  
**Types of ControlLogix Digital I/O Modules**

Catalog Number:	Description:	RTB:
1756-IA16	79-132V ac 16 pt. input module	20 pin
1756-IA16I	79-132V ac 16 pt. isolated input module	36 pin
1756-IA8D	79-132V ac 8pt. diagnostic input module	20 pin
1756-IB16	10-31V dc 16 pt. input module	20 pin
1756-IB16D	10-30V dc diagnostic input module	36 pin
1756-IB16I	10-30V dc 16 pt. isolated input module	36 pin
1756-IB32	10-31V dc 32 pt. input module	36 pin
1756-IC16	30-60V dc 16 pt. input module	20 pin
1756-IH16I	90-146V dc 16 pt. isolated input module	36 pin
1756-IM16I	159-265V ac 16 pt. isolated input module	36 pin
1756-IN16	10-30V ac 16 pt. input module	20 pin
1756-IV16	10-31V dc 16 pt. sourcing current input module	20 pin
1756-IV32	10-31V dc 32 pt. sourcing current input module	36 pin

**Table 1.B**  
**Types of ControlLogix Digital I/O Modules**

<b>Catalog Number:</b>	<b>Description:</b>	<b>RTB:</b>
1756-OA16	74-265V ac 16 pt. output module	20 pin
1756-OA16I	74-265V ac 16 pt. isolated output module	36 pin
1756-OA8	74-265V ac 16 pt. output module	20 pin
1756-OA8D	74-132V ac 8 pt. diagnostic output module	20 pin
1756-OA8E	74-132V ac 8 pt. e-fused output module	20 pin
1756-OB16D	19-30V dc 16 pt. diagnostic output module	36 pin
1756-OB16E	10-31V dc 16 pt. e-fused output module	20 pin
1756-OB16I	10-30V dc 16 pt. isolated output module	36 pin
1756-OB32	10-31V dc 32 pt. output module	36 pin
1756-OB8	10-30V dc 8 pt. output module	20 pin
1756-OB8EI	10-30V dc 8 pt. e-fused isolated output module	36 pin
1756-OC8	30-60V dc 8 pt. output module	20 pin
1756-OH8I	90-146V dc 8 pt. isolated output module	36 pin
1756-ON8	10-30V ac 8 pt. output module	20 pin
1756-OV16E	10-31V dc 16 pt. e-fused sinking current output module	20 pin
1756-OW16I	10-265V 16 pt. isolated relay output module	36 pin
1756-OX8I	10-265V, 5-150V dc 8 pt. isolated relay normally open, normally closed output module	36 pin

## Features of the ControlLogix Digital I/O Modules

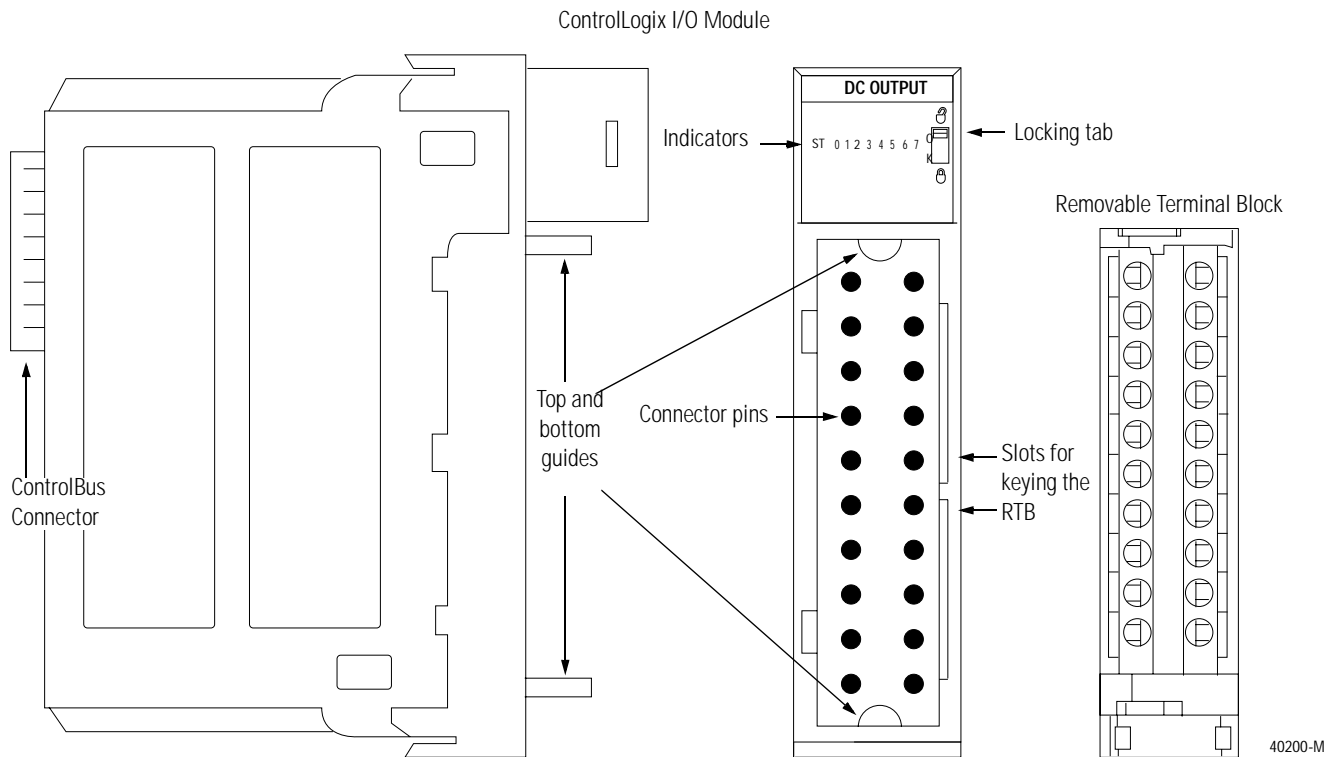

**ControlBus connector** - The backplane connector interface for the ControlLogix system connects the module to the ControlBus backplane.

**Connectors pins** - Input/output, power and grounding connections are made to the module through these pins with the use of an RTB or IFM.

**Locking tab** - The locking tab anchors the RTB or IFM cable on the module, maintaining wiring connections.

**Slots for keying** - Mechanically keys the RTB to prevent inadvertently making the wrong wire connections to your module.

**Status indicators** - Indicators display the status of communication, module health and input/output devices. Use these indicators to help in troubleshooting.

**Top and bottom guides** - Guides provide assistance in seating the RTB or IFM cable onto the module.

## Using Module Identification and Status Information

Each ControlLogix I/O module maintains specific identification information that separates it from all other modules. This information assists you in tracking all the components of your system.

For example, you can track module identification information to be aware of exactly what modules are located in any ControlLogix rack at any time. While retrieving module identity, you can also retrieve the module's status.

Each module maintains the following information:

**Table 1.C**  
**Module Identification and Status Information**

<b>Module Identification:</b>	<b>Description:</b>
Product Type	Module's product type, such as Digital I/O or Analog I/O module
Catalog Code	Module's catalog number
Major Revision	Module's major revision number
Minor Revision	Module's minor revision number
Status	Module's status. Returns the following information: <ul style="list-style-type: none"> <li>• Controller ownership (if any)</li> <li>• Whether module has been configured</li> <li>• Device Specific Status, such as: <ul style="list-style-type: none"> <li>–Self-Test</li> <li>–Flash update in progress</li> <li>–Communications fault</li> <li>–Not owned (outputs in prog. mode)</li> <li>–Internal fault (need flash update)</li> <li>–Run mode</li> <li>–Program mode (output mods only)</li> </ul> </li> <li>• Minor recoverable fault</li> <li>• Minor unrecoverable fault</li> <li>• Major recoverable fault</li> <li>• Major unrecoverable fault</li> </ul>
Vendor ID	Module manufacturer vendor, for example Allen-Bradley
Serial Number	Module serial number
Length of ASCII Text String	Number of characters in module's text string
ASCII Text String	Number of characters in module's text string

### **IMPORTANT**

You must perform a WHO service to retrieve this information. For more information on how to retrieve module identification information, see Appendix B.

## Preventing Electrostatic Discharge

This module is sensitive to electrostatic discharge.

---

**ATTENTION**

Electrostatic discharge can damage integrated circuits or semiconductors if you touch backplane connector pins. Follow these guidelines when you handle the module:

- Touch a grounded object to discharge static potential
  - Wear an approved wrist-strap grounding device
  - Do not touch the backplane connector or connector pins
  - Do not touch circuit components inside the module
  - If available, use a static-safe work station
  - When not in use, keep the module in its static-shield box
- 

## Removal and Insertion Under Power

These modules are designed to be installed or removed while chassis power is applied.

---

**ATTENTION**

When you insert or remove a module while backplane power is applied, an electrical arc may occur. An electrical arc can cause personal injury or property damage by:

- sending an erroneous signal to your system's field devices causing unintended machine motion or loss of process control.
- causing an explosion in a hazardous environment.

Repeated electrical arcing causes excessive wear to contacts on both the module and its mating connectors. Worn contacts may create electrical resistance that can affect module operation.

---

## Chapter Summary and What's Next

In this chapter you learned about:

- what ControlLogix digital I/O modules are.
- types of ControlLogix digital I/O modules.

Move on to Chapter 2, Digital I/O Operation in the ControlLogix System.

## Digital I/O Operation in the ControlLogix System

**What This Chapter Contains** This chapter describes how digital I/O modules work within the ControlLogix system.

<b>For information about:</b>	<b>See page:</b>
Ownership	2-2
Using RSNetWorx and RSLogix 5000	2-2
Internal Module Operations	2-4
Direct Connections	2-6
Input Module Operation	2-9
Input Modules in a Local Chassis	2-10
Requested Packet Interval (RPI)	2-10
Change of State (COS)	2-10
Input Modules in a Remote Chassis	2-11
Output Module Operation	2-14
Output Modules in a Local Chassis	2-14
Output Modules in a Remote Chassis	2-15
Listen-Only Mode	2-17
Multiple Owners of Input Modules	2-18
Configuration Changes in an Input Module with Multiple Owners	2-19
Rack Connections	2-7
Suggestions for Rack Connection Usage	2-8
Chapter Summary and What's Next	2-20

## Ownership

Every I/O module in the ControlLogix system must be owned by a Logix5550 Controller. This owner-controller:

- stores configuration data for every module that it owns.
- can be local or remote in regard to the I/O module's position.
- sends the I/O module configuration data to define the module's behavior and begin operation with the control system.

Each ControlLogix I/O module must continuously maintain communication with its owner to operate normally.

Typically, each module in the system will have only 1 owner. Input modules can have more than 1 owner. Output modules, however, are limited to a single owner.

For more information on the increased flexibility provided by multiple owners and the ramifications of using multiple owners, see page 2-13.

## Using RSNetWorx and RSLogix 5000

The I/O configuration portion of RSLogix5000 generates the configuration data for each I/O module in the control system, whether the module is located in a local or remote chassis. A remote chassis, also known as networked, contains the I/O module but not the module's owner controller.

Configuration data is transferred to the controller during the program download and subsequently transferred to the appropriate I/O modules.

### I/O Modules in Local Chassis

I/O modules in the same chassis as the controller are ready to run as soon as the configuration data has been downloaded.

## I/O Modules in Remote Chassis

You must run RSNetWorx to enable I/O modules in the networked chassis. Running RSNetWorx transfers configuration data to networked modules and establishes a Network Update Time (NUT) for ControlNet. The NUT is compliant with the desired communications options specified for each module during configuration.

---

**IMPORTANT**

If you are not using I/O modules in a networked chassis, running RSNetWorx is not necessary. However, anytime a controller references an I/O module in a networked chassis, you must run RSNetWorx to configure ControlNet.

---

Follow these guidelines when configuring I/O modules:

1. Configure all I/O modules for a given controller using RSLogix 5000 and download that information to the controller.
2. If the I/O configuration data references a module in a remote chassis, run RSNetWorx.

---

**IMPORTANT**

RSNetWorx **must** be run whenever a new module is added to a networked chassis. When a module is permanently removed from a remote chassis, we recommend that Networx be run to optimize the allocation of network bandwidth.

---

## Internal Module Operations

Signal propagation delays exist with ControlLogix I/O modules that must be accounted for when operating them. Some of these delays are user selectable, and some are inherent to the module hardware. For example, there is a small delay (typically less than 1mS) between when a signal is applied at the RTB of a ControlLogix input module and when a signal is sent to the system over the ControlBus (This typical time reflects a filter time choice of 0mS for a DC input.).

This section offers a graphical explanation of the time limitations with ControlLogix I/O modules.

### Input Modules

As shown below, ControlLogix input modules receive a signal at the RTB and process it internally (i.e. hardware delay, filter delay, ASIC delay) before sending a signal to the ControlBus via the Requested Packet Interval (RPI) or at the Change of State (COS).

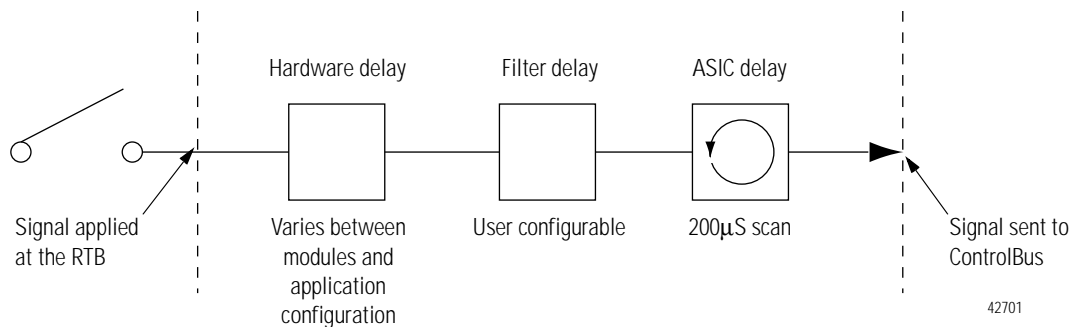

#### EXAMPLE

Many factors (e.g. module type, voltage, temperature, if the module is turning ON or OFF) affect the signal propagation delay on a module. But a typical delay time can be estimated.

For example, if you are turning ON a 1756-IB16 module, the signal propagation delay is affected by:

- hardware delay to energize the module (typically 200µS on this module)
- user-configurable filter time (0, 1, or 2mS)
- ASIC scan (200µS)

In the best case scenario (i.e. filter time of 0mS), the 1756-IB16 module has a 400µS signal propagation delay at 24V dc in 25°C.

These times are not guaranteed. We list maximum delay times for each module in the specifications.

## Output Modules

ControlLogix output modules receive a signal from the controller and process it internally (i.e. ASIC delay and hardware delay) before sending a signal to the output device via the RTB.

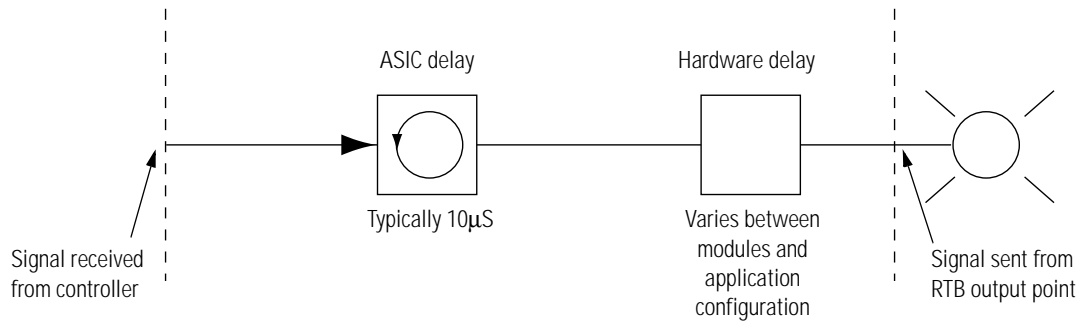

42702

### EXAMPLE

As previously stated, many factors (e.g. module type, voltage, temperature, if the module is turning ON or OFF) affect the signal propagation delay on a module. But a typical delay time can be estimated.

For example, if you are turning ON a 1756-OB16E module, the signal propagation delay is affected by:

- hardware delay to energize the module (typically 200µS on this module)
- ASIC scan (10µS)

In the best case scenario, the 1756-OB16E module has a 210µS signal propagation delay at 24V dc in 24°C.

These times are not guaranteed. We list maximum delay times for each module in the specifications.

## Connections

A connection is the data transfer link between a controller and the device that occupies the slot that the configuration data references, in this case, the I/O module. There are two types of connections:

- Direct Connections
- Rack Connections

The following sections describe each type of connection. See Table 2.A on page 2-9 for differences between connection types. The table also lists the advantages and disadvantages of each type.

### Direct Connections

A **direct connection** is a real-time data transfer link between the controller and the device that occupies the slot that the configuration data references. When module configuration data is downloaded to an owner-controller, the controller attempts to establish a direct connection to each of the modules referenced by the data.

If a controller has configuration data referencing a slot in the control system, the controller periodically checks for the presence of a device there. When a device's presence is detected there, the controller automatically sends the configuration data.

If the data is appropriate to the module found in the slot, a connection is made and operation begins. If the configuration data is not appropriate, the data is rejected and an error message displays in the software. In this case, the configuration data can be inappropriate for any of a number of reasons. For example, a module's configuration data may be appropriate except for a mismatch in electronic keying that prevents normal operation.

The controller maintains and monitors its connection with a module. Any break in the connection, such as module faults or removal of the module from the chassis while under power, causes the controller to set fault status bits in the data area associated with the module. The RSLogix 5000 software monitors this data area to annunciate the modules' failures.

---

**IMPORTANT**

While a Logix5550 controller allows up to 250 bidirectional connections, each individual I/O module allows 16 bidirectional connections.

---

## Rack Connections

When a digital I/O module is located in a remote chassis (with respect to its owner), you may select **rack optimization** or **listen-only rack optimization** in the Communications Format field during initial module configuration. This depends on the bridge module (1756-CNB) configuration. If the CNB is selected for Listen-Only rack option, then the I/O module only allows the Listen-Only rack option.

A rack connection economizes connection usage between the owner and digital I/O in the remote chassis. Rather than having several direct connections with individual RPI values, the owner has a single rack connection with a single RPI value. That RPI value accommodates all digital I/O modules in the rack connection.

---

**IMPORTANT**

Because rack connections are only applicable in applications that use a remote chassis, you must configure the Communications Format for both the remote I/O module and the remote 1756-CNB module.

Make sure you configure both modules for Rack Optimization. If you choose a different Communications Format for each, the controller makes two connections to the same chassis (one for each format) and the same data travels across ControlNet.

If you use Rack Optimization for both modules, you preserve bandwidth and configure your system to operate more efficiently.

---

The input (or data echo) information is limited to general faults and data. No additional status (e.g. diagnostic) is available.

---

**IMPORTANT**

Each controller can only establish 255 connections, in any combination of direct or rack. In other words, you can use a rack connection between an owner controller and multiple remote I/O modules while simultaneously using a direct connection between that same controller and any other I/O modules in the same remote chassis.

---

In this example, the owner is still communicating with all I/O in the remote chassis, but has used only one connection. The data from all three modules is sent together simultaneously at the RPI. This option eliminates the need for three separate connections.

**Using a Rack Connection with I/O in a Remote Chassis**

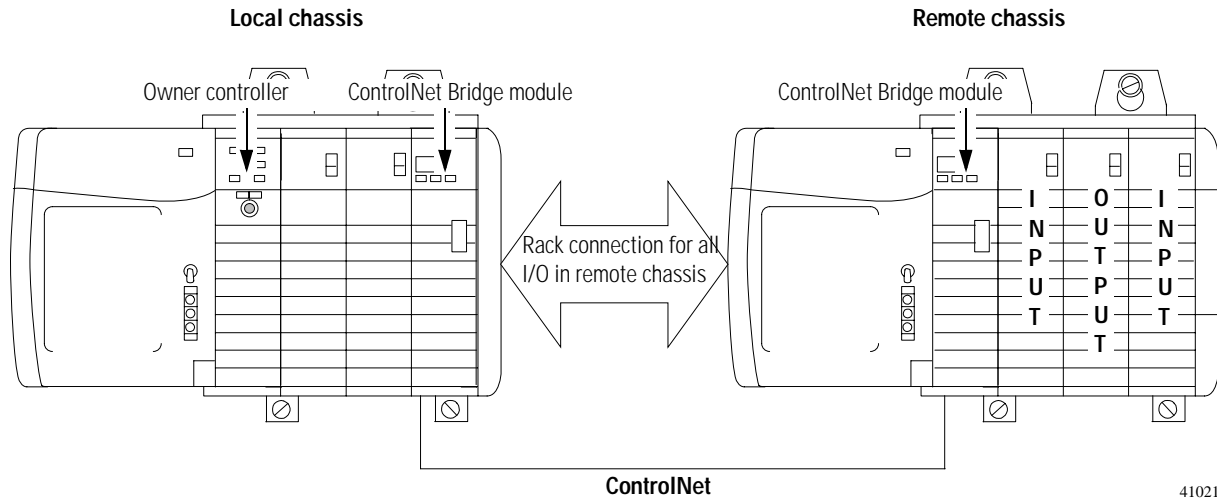

**IMPORTANT**

Rack connections are only available to digital I/O modules. Although analog modules can only use direct connections, the system can make both direct and rack connections to the same chassis.

**Suggestions for Rack Connection Usage**

We recommend that you use a rack connection for applications in which:

- standard digital I/O modules are used.
- non-fused digital output modules are used.
- your owner controller is running low on connections.

**IMPORTANT**

Do not use a rack connection for diagnostic I/O modules or fused output modules. Diagnostic and fused output data will not be transferred over a rack connection. This defeats the purpose of using those modules.

Also remember, while a Logix5550 controller allows up to 250 bidirectional connections, each individual I/O module allows 16 bidirectional connections.

Table 2.A lists the differences between connection types and the advantages/disadvantages of each.

**Table 2.A**  
**Differences Between Direct and Rack Connections**

Connection Type	Advantages	Disadvantages
Direct connections	All input and data echo information is transferred, including diagnostic information and fusing data.	With more data transferring over ControlNet, your system does not operate as efficiently as with rack connections.
Rack connections	Connection usage is economized. The owner-controller has a single RPI value.	Input and data echo information is limited to general faults and data.

## Input Module Operation

In traditional I/O systems, controllers poll input modules to obtain their input status. Digital input modules in the ControlLogix system are not polled by a controller. Instead, the modules multicast their data either upon Change of State or periodically. The frequency depends on the options chosen during configuration and where in the control system that input module physically resides.

### **IMPORTANT**

This is called the Producer/Consumer model. The input module is the producer of input data and the controller is the consumer of the data.

An input module's behavior varies depending upon whether it operates in the local chassis or in a remote chassis. The following sections detail the differences in data transfers between these set-ups.

## Input Modules in a Local Chassis

When a module resides in the same chassis as the owner controller, the following two configuration parameters will affect how and when an input module multicasts data:

- Requested Packet Interval (RPI)
- Change of State (COS)

### Requested Packet Interval (RPI)

This interval specifies the rate at which a module multicasts its data. The time ranges from 200 microseconds to 750 milliseconds and is sent to the module with all other configuration parameters. When the specified time frame elapses, the module will multicast data. This is also called a cyclic update.

### Change of State (COS)

This parameter instructs the module to transfer data whenever a specified input point transitions from ON to OFF or OFF to ON.

---

**IMPORTANT**

The module COS feature defaults to both ON to OFF and OFF to ON enabled.

---

COS selection occurs on a per-point basis, but all module data is multicast when any point enabled for COS changes state. COS is more efficient than RPI because it multicasts data only when a change occurs.

---

**IMPORTANT**

You must specify an RPI regardless of whether you enable COS. If a change does not occur within the RPI timeframe, the module will still multicast data at the rate specified by the RPI.

---

For example, if an input is changing state consistently every 2 seconds and the RPI is set at 750mS, the data transfer will look like this:

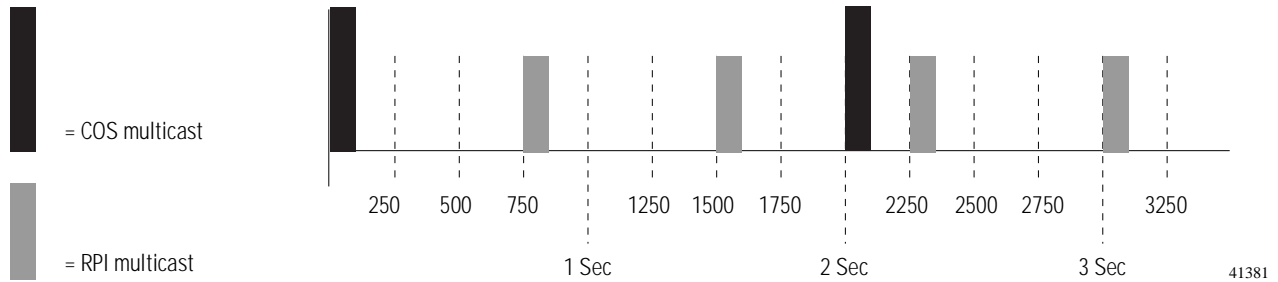

Because the RPI and COS functions are asynchronous to the program scan, it is possible for an input to change state during program scan execution. The point must be “buffered” to prevent this. Copy the input data from your input tags to another structure and use the data from there.

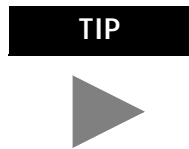

To minimize traffic and conserve bandwidth, we recommend you use a larger RPI value if the COS option is used and the module is located in the same chassis as its owner.

## Input Modules in a Remote Chassis

If an input module physically resides in a chassis other than where the owner controller is (i.e. a remote chassis connected via ControlNet), the role of the RPI and the module’s COS behavior changes slightly with respect to getting data to the owner.

The RPI and COS behavior still define when the module will multicast data **within its own chassis** (as described in the previous section), but only the value of the RPI determines when the owner controller will receive it over the network.

When an RPI value is specified for an input module in a remote chassis, in addition to instructing the module to multicast data within its own chassis, the RPI also “reserves” a spot in the stream of data flowing across the ControlNet network.

The timing of this “reserved” spot may or may not coincide with the exact value of the RPI, but the control system will guarantee that the owner-controller will receive data **at least as often** as the specified RPI.

**Input Module in Remote Chassis with Data Coming At Least as Often as RPI**

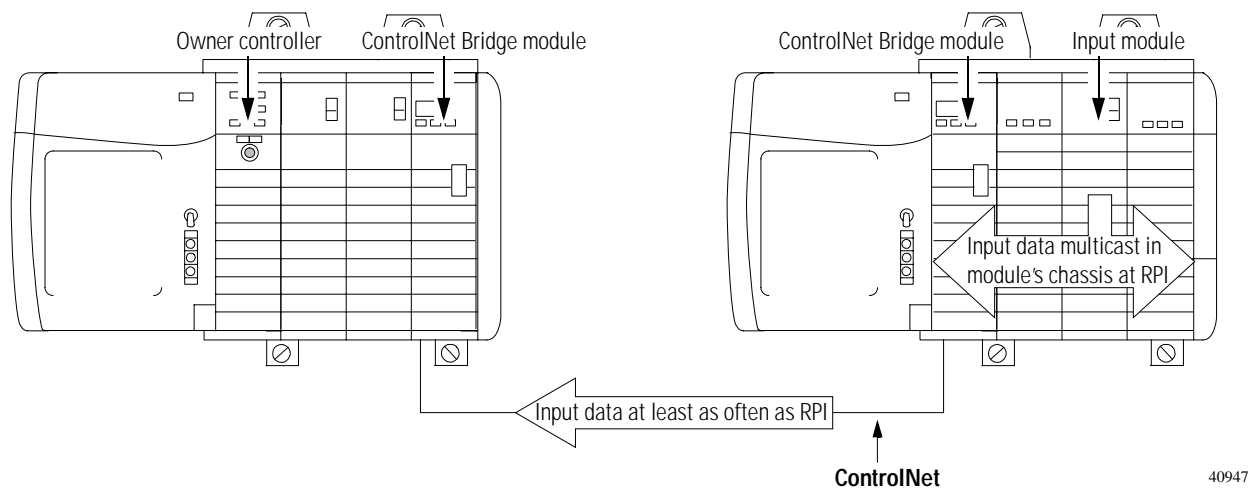

The “reserved” spot on the network and the module’s RPI are asynchronous to each other. This means there are Best and Worst Case scenarios as to when the owner controller will receive updated channel data from the module in a networked chassis.

### Best Case RPI Multicast Scenario

In the Best Case scenario, the module performs an RPI multicast with updated channel data just before the “reserved” network slot is made available. In this case, the remotely located owner receives the data almost immediately.

## Worst Case RPI Multicast Scenario

In the Worst Case scenario, the module performs an RPI multicast just after the “reserved” network slot has passed. In this case, the owner-controller will not receive data until the next available network slot.

### IMPORTANT

Enabling the COS feature on an input module in a remote chassis allows the module to multicast data at both the RPI rate and when the input changes state. This helps to **reduce the Worst Case time**.

Table 2.B summarizes the Best Case and Worst Case scenarios, from the time an input changes state to the time the owner-controller will receive the data:

**Table 2.B**  
Best and Worst Case Scenarios For Remote Input Data Transfer

	Best case scenario	Worst case scenario
<b>COS disabled</b>	Backplane/Network transfer times (<1mS)	Twice the RPI
<b>COS enabled</b>	Backplane/Network transfer times (<1mS)	Slightly less than the RPI

When selecting values for the remotely located module’s RPI, system throughput is optimized when its RPI value is a power of 2 times the current NUT running on ControlNet.

For example, Table 2.C shows recommended RPI values for a system using a NUT of 5mS:

**Table 2.C**  
Recommended RPI Values for System Using NUT of 5mS

NUT=5mS	x2 <sup>0</sup>	x2 <sup>1</sup>	x2 <sup>2</sup>	x2 <sup>3</sup>	x2 <sup>4</sup>	x2 <sup>5</sup>	x2 <sup>6</sup>	x2 <sup>7</sup>
Optimal RPI Values (mS)	5mS	10mS	20mS	40mS	80mS	160mS	320mS	640mS

## Output Module Operation

An owner controller sends output data to an output module when either one of two things occur:

- at the end of every one of its program scans (local chassis only) and/or
- at the rate specified in the module's RPI

When an output module physically resides in a remote chassis (with respect to the owner-controller), the owner-controller sends data to the output module **only** at the RPI rate specified for the module. Updates are not performed at the end of the owner-controller's program scan.

Whenever the module receives data from the controller, it immediately multicasts the output commands it received to the rest of the system. The actual output data is echoed by the output module as input data and multicast back out onto the network. This is called **Output Data Echo**. The Output Data Echo also may contain fault and diagnostic information, depending on the module type.

### IMPORTANT

In this Producer/Consumer model, the output module is the Consumer of the controller's output data and the Producer of the data echo.

## Output Modules in a Local Chassis

When you specify an RPI value for a digital output module, you instruct the owner-controller when to broadcast the output data to the module. If the module resides in the same chassis as the owner-controller, the module receives the data almost immediately after the owner-controller sent it (backplane transfer times are small).

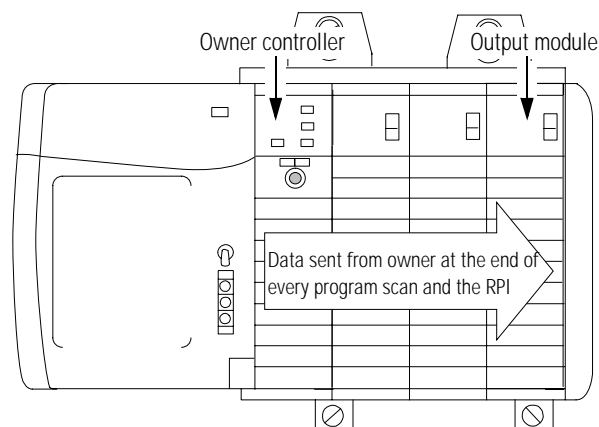

40949

Depending on the value of the RPI, with respect to the length of the program scan, the output module can receive and "echo" data multiple times during one program scan.

## Output Modules in a Remote Chassis

If an output module physically resides in a chassis other than that of the owner controller (i.e. a remote chassis connected via ControlNet), the owner controller sends data to the output module **only** at the RPI rate specified. Updates are **not** performed at the end of the controller's program scan.

In addition, the role of the RPI for a remote output module changes slightly, with respect to getting data from the owner-controller.

When an RPI value is specified for an output module in a remote chassis, in addition to instructing the owner-controller to multicast the output data within its own chassis, the RPI also “reserves” a spot in the stream of data flowing across the ControlNet network.

The timing of this “reserved” spot may or may not coincide with the exact value of the RPI, but the control system will guarantee that the output module will receive data **at least as often** as the specified RPI.

Output Module in Remote Chassis with Data Coming At Least as Often as RPI

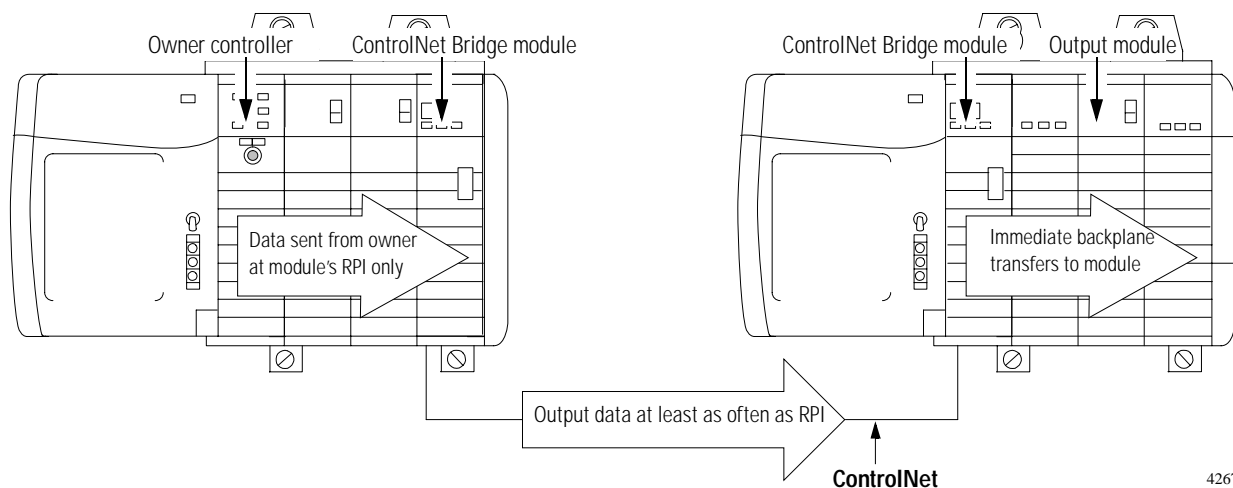

42675

The “reserved” spot on the network and when the controller sends the output data are asynchronous to each other. This means there are Best and Worst Case scenarios as to when the owner controller will receive updated channel data from the module in a networked chassis.

## Best Case RPI Multicast Scenario

In the Best Case scenario, the owner-controller sends the output data just before the “reserved” network slot is made available. In this case, the remotely located output module receives the data almost immediately.

## Worst Case RPI Multicast Scenario

In the Worst Case scenario, the owner-controller sends the output data just after the “reserved” network slot has passed. In this case, the output module does not receive data until the next available network slot.

Table 2.D shows the Best Case and Worst Case times for output data sent from a controller to reach the output module:

**Table 2.D**  
**Best and Worst Case Times for Remote Output Data Transfer**

Best case time	Worst case time
Backplane/Network transfer times (<1mS)	RPI rate

---

**IMPORTANT**

These Best and Worst Case scenarios indicate the time required for output data to transfer from the owner-controller to the module **once the owner-controller has produced it**. They do not take into account the user program time in the owner-controller.

The receipt of new data is a function of the length of the user program and its asynchronous relationship with the RPI.

---

## Listen-Only Mode

Any controller in the system can **listen** to the data from any I/O module (e.g. input data, “echoed” output data, or “echoed” diagnostic information) even if the controller does not own the module (i.e. it does not have to hold the module’s configuration data to listen to the module).

During the I/O configuration process, you can specify one of several ‘Listen’ modes in the Communication Format field. For more information on Communication Format, see page 6-6.

Choosing a ‘Listen’ mode option allows the controller and module to establish communications without the controller sending any configuration data. In this instance, another controller owns the module being listened to.

---

**IMPORTANT**

In the Listen-Only mode, controllers will continue to receive data multicast from the I/O module as long as the connection between the owner and I/O module is maintained.

If the connection between owner and module is broken, the module stops multicasting data and connections to all ‘Listening controllers’ are also broken.

---

## Multiple Owners of Input Modules

Because 'Listening controllers' lose their connections to modules when communications with the owner stop, the ControlLogix system will allow you to define more than one owner for input modules.

**IMPORTANT**

Only input modules can have multiple owners. If multiple owners are connected to the same input module, they **must maintain identical configuration** for that module.

In the example below, Controller A and Controller B have both been configured to be the owner of the input module.

Multiple Owners with Identical Configuration Data

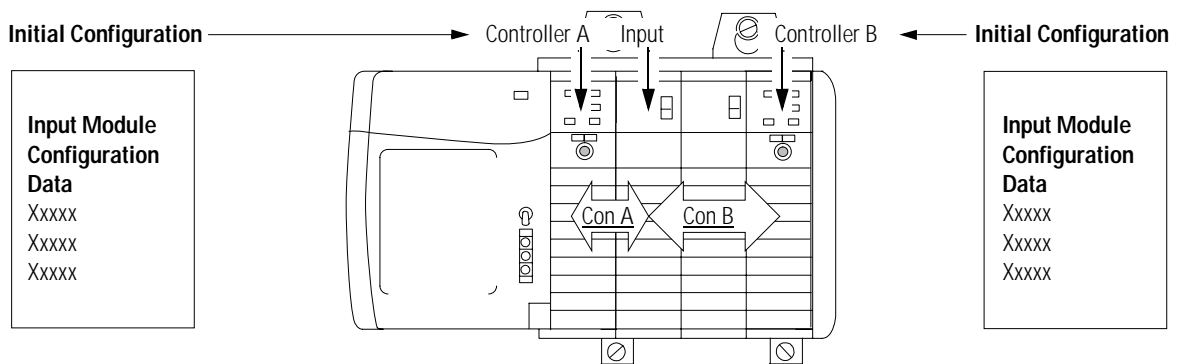

41056

As soon as a controller receives its user program, it will try to establish a connection with the input module. Whichever controller's configuration data arrives first establishes a connection. When the second controller's data arrives, the module compares it to its current configuration data (the data received and accepted from the first controller).

If the configuration data sent by the second controller matches the data sent by the first controller, that connection is also accepted. If any parameter of the second configuration data is different from the first, the module rejects the connection and the user is informed by an error in the software or programmatically via a ladder logic program.

The advantage of multiple owners over a 'Listen mode' connection is that now either of the controllers can break the connection to the module and the module will continue to operate and multicast data to the system because of the connection maintained by the other controller.

## Configuration Changes in an Input Module with Multiple Owners

You must be careful when changing an input module's configuration data in a multiple owner scenario. When the configuration data is changed in one of the owners, for example, Controller A, and sent to the module, that configuration data is accepted as the new configuration for the module. Controller B will continue to listen, unaware that any changes have been made in the module's behavior.

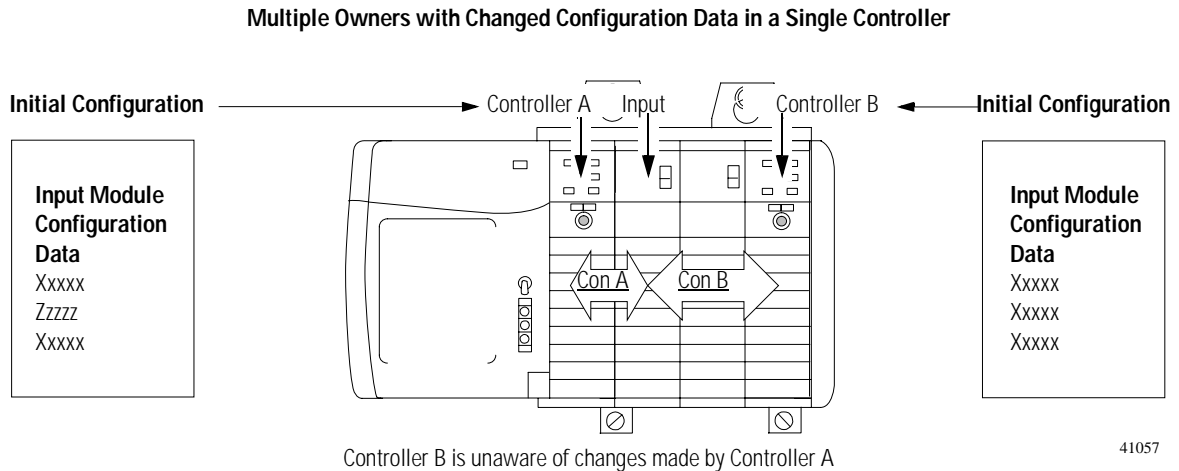

To prevent other owners from receiving potentially erroneous data, as described above, the following steps **must be followed** when changing a module's configuration in a multiple owner scenario when online:

1. Make the appropriate configuration data changes in the software and apply them.

When you apply new configuration data, the software alerts you to **inhibit** the module (recommended if you are using a **multiple controller system**) or perform a **bumpless** reconfiguration (recommended if you are using a **single controller system**). For a complete explanation of a bumpless reconfiguration, see page P-2.

2. Repeat step 1 for all owner controllers, making the **exact same changes** in all controllers.
3. Disable the Inhibit box in each owner's configuration, if you enabled this box in step 1.

---

**IMPORTANT**

If all owner controllers have exactly the same configuration after you have made changes, all the controllers will reestablish communication with the input module.

If multiple controllers have different configuration after you have made changes, only one controller (the first one to send changes to the module) will reestablish communications with the input module.

---

## Chapter Summary and What's Next

In this chapter you learned about:

- ownership and connections
- direct connections
- rack connections
- input module operation
- output module operation

Move to Chapter 3, ControlLogix Standard Digital I/O Module Features.

## ControlLogix Standard Digital I/O Module Features

**What This Chapter Contains** This chapter describes devices compatible with ControlLogix I/O and features that are specific to various modules.

For information about:	See page:
Determining Input Module Compatibility	3-1
Determining Output Module Compatibility	3-2
Using Features Common to ControlLogix Standard Digital I/O Modules	3-3
Using Features Specific to Standard Input Modules	3-11
Using Features Specific to Standard Output Modules	3-12
Fault and Status Reporting Between Input Modules and Controllers	3-18
Fault and Status Reporting Between Output Modules and Controller	3-19
Chapter Summary and What's Next	3-21

### Determining Input Module Compatibility

ControlLogix digital input modules interface to sensing devices and detect whether they are ON or OFF.

ControlLogix input modules convert ac or dc ON/OFF signals from user devices to appropriate logic level for use within the processor. Typical input devices include:

- proximity switches
- limit switches
- selector switches
- float switches
- pushbutton switches

When designing a system using ControlLogix input modules, you must consider:

- the voltage necessary for your application
- whether you need a solid state device
- current leakage
- if your application should use sinking or sourcing wiring.

For more information on compatibility of other Allen-Bradley Company products to ControlLogix input modules, see the I/O Systems Overview, publication CIG-2.1.

## Determining Output Module Compatibility

ControlLogix output modules may be used to drive a variety of output devices. Typical output devices compatible with the ControlLogix outputs include:

- motor starters
- solenoids
- indicators

When designing a system:

- make sure that the ControlLogix outputs can supply the necessary surge and continuous current for proper operation.
- make sure that the surge and continuous current are not exceeded. Damage to the module could result.

When sizing output loads, check the documentation supplied with the output device for the surge and continuous current needed to operate the device.

The ControlLogix outputs are capable of directly driving the ControlLogix inputs. The exceptions are the ac and dc diagnostic input modules. When diagnostics are used a shunt resistor is required for leakage current.

For more information specifically on the compatibility of motor starters to ControlLogix output modules, see Appendix D.

For more information on compatibility of other Allen-Bradley Company products to ControlLogix output modules, see the I/O Systems Overview, publication CIG-2.1.

## Using Features Common to ControlLogix Standard Digital I/O Modules

The following features are common to all ControlLogix standard digital I/O modules:

### Removal and Insertion Under Power (RIUP)

All ControlLogix I/O modules may be inserted and removed from the chassis while power is applied. This feature allows greater availability of the overall control system because, while the module is being removed or inserted, there is no additional disruption to the rest of the controlled process.

### Module Fault Reporting

ControlLogix digital I/O modules provide both hardware and software indication when a module fault has occurred. Each module's LED fault indicator and RSLogix 5000 will graphically display this fault and include a fault message describing the nature of the fault.

This feature allows you to determine how your module has been affected and what action should be taken to resume normal operation.

### Fully Software Configurable

The RSLogix 5000 software uses a custom, easily understood interface to write configuration. All module features are enabled or disabled through the I/O configuration portion of the software.

You can also use the software to interrogate any module in the system to retrieve

- serial number
- revision information
- catalog number
- vendor identification
- error/fault information
- diagnostic counters.

By eliminating such tasks as setting hardware switches and jumpers, the software makes module configuration easier and more reliable.

## Electronic Keying

Instead of plastic mechanical backplane keys, electronic keying allows the ControlLogix system to control what modules belong in the various slots of a configured system.

During module configuration, you must choose one of the following keying options for your I/O module:

- Exact Match
- Compatible Match
- Disable Keying

The options above are described later in this section.

When the controller attempts to connect to and configure an I/O module (e.g. after program download), the module compares the following parameters before allowing the connection and configuration to be accepted:

- Vendor
- Product Type
- Catalog Number
- Major Revision - Change that affects the module's function or RSLogix 5000 interface
- Minor Revision - Change that does not affect the module's function or RSLogix 5000 interface

The comparison is made between the keying information present in the I/O module and the keying information in the controller's program. This feature can prevent the inadvertent operation of a control system with the wrong module in the wrong slot.

### *Exact Match*

All of the parameters listed above must match or the inserted module will reject a connection to the controller.

### *Compatible Match*

The Compatible Match mode allows an I/O module to determine whether it can emulate the module defined in the configuration sent from the controller.

With ControlLogix digital I/O modules, the module can emulate older revisions. The module will accept the configuration if the configuration's major.minor revision is less than or equal to the physical module's revision.

For example, if the configuration contains a major.minor revision of 2.7, the module inserted into the slot must have a firmware revision of 2.7 or higher for a connection to be made.

#### TIP



We recommend using Compatible Match whenever possible. Remember, though, the module will only work to the level of the configuration.

For example, if a slot is configured for a module with major.minor revision of 2.7 and you insert a module with a major.minor revision of 3.1, the module works at the 2.7 level despite having been previously upgraded.

If possible, we suggest you make sure configuration is updated to match the revision levels of all I/O modules. Failure to do so may not prevent the application from working but may defeat the purpose of upgrading your modules' revision levels.

### *Disable Keying*

The inserted module attempts to accept a connection to the controller regardless of its type.

---

**ATTENTION**

Be extremely cautious when using the disable keying option; if used incorrectly, this option can lead to personal injury or death, property damage or economic loss.

---

If keying is disabled, a controller makes a connection with most modules of the same type as that used in the slot configuration. For example, if a slot is configured for a 1756-IA16I (standard input module), and a 1756-IB16 (standard input module) is inserted into the slot, the controller established a connection because keying is disabled.

A controller will not establish a connection if any of the following conditions exist, even if keying is disabled:

- The slot is configured for one module type (e.g. input module) and a module of another type (e.g. output module) is inserted in the slot.
- The module inserted into the slot cannot accept some portion of the configuration. For example, if a standard input module is inserted into a slot configured for a diagnostic input module, the controller cannot make a connection because the module cannot accept/process the diagnostic configuration.

## Using the System Clock to Timestamp Inputs and Schedule Outputs

Controllers generate a 64-bit Coordinated System Time (CST) for their respective chassis. The CST is a chassis-specific time that is not synchronized with, or in any way connected to, the time generated over ControlNet to establish a NUT, as described in Chapter 2.

You can configure your digital input modules to access the CST and **timestamp input data** with a relative time reference (i.e. the value of the CST) of when that input data changes state.

---

**IMPORTANT**

Because only one CST value is returned to the controller when any input point changes state, it is recommended that you use timestamping on only one input point per module.

---

### *Timestamping for a Sequence of Events*

The CST can be used to establish a sequence of events occurring at a particular input module point by timestamping the input data. To determine a sequence of events, you must:

- Set the input module's communications format to: CST Timestamped Input Data
- Enable Change of state for the input point where a sequence will occur (Disable COS for all other points on the module)

**TIP**

If you decide to configure multiple input points for COS, your module generates a unique CST each time any of those input points change state, as long as the changes do not occur within 500 $\mu$ S of each other.

If multiple input points configured for COS change state within 500 $\mu$ s of each other, a single CST value is generated for all, making it appear that they changed at exactly the same time.

### *Timestamping In Conjunction with Scheduled Outputs*

Timestamping can be used in conjunction with the **scheduled outputs** feature so that after input data changes state and a timestamp occurs, an output point will actuate at some configured time in the future. You can schedule outputs up to 16 seconds into the future.

When you use timestamping of inputs and scheduled outputs, you must:

- choose a Communications Format for each input and output module that allows timestamping. For more information on choosing a Communications Format, see Chapter 6.
- have a controller in the same rack as both I/O modules
- disable Change of State for all input points on the input module except the point being timestamped

**TIP**

For scheduled outputs to work most effectively, remember the following:



- The time to schedule outputs to transition in the future must account for any controller, backplane and network delays.
- The I/O modules must reside in the same rack as the timemaster.

For a detailed example of how to write ladder logic to use these features, see Appendix B.

### *Module Major Revision Considerations with Timestamping*

When using timestamping for inputs or diagnostic timestamping of I/O modules, remember the following conditions that may occur depending on the module's Major Revision:

- If the module has a Major Revision = 1, it will always return a positive timestamping value.
- If the module has a Major Revision  $\geq 2$ , it will return a negative timestamping value until the module is synchronized with the owner-controller and the first Change of State condition occurs.

Look at the Module Properties page of RSLogix 5000 to determine if the module has been synchronized with the owner-controller and whether the controller is synchronized with the CST.

For more information on synchronizing owner-controllers and modules with the CST, see the ControlLogix System User Manual, publication 1756-UM001.

### **Producer/Consumer Model**

By using the Producer/Consumer model, ControlLogix I/O modules can produce data without having been polled by a controller first. The modules produce the data and any other owner controller device can decide to consume it.

For example, an input module produces data and any number of processors can consume the data at the same time. This eliminates the need for one processor to send the data to another processor. For a more detailed explanation of this process, see Chapter 2.

## LED Status Information

Each ControlLogix digital I/O module has an LED indicator on the front of the module that allows you to check the module health and operational status of a module. The LED displays vary for each module.

The following status can be checked with the LED indicators:

- **I/O status** - This yellow display indicates the ON/OFF state of the field device.

---

**IMPORTANT**

For the 1756-OA8D and 1756-OA8E modules, the I/O status indicator does not illuminate without field power applied.

---

- **Module status** - This green display indicates the module's communication status.
- **Fault status** - This display is only found on some modules and indicates the presence or absence of various faults.
- **Fuse status** - This display is only found on electronically fused modules and indicates the state of the module's fuse.

For examples of LED indicators on ControlLogix digital I/O modules, see Chapter 7.

## Full Class I Division 2 Compliance

All ControlLogix digital I/O modules maintain CSA Class I Division 2 system certification. This allows the ControlLogix system to be placed in an environment other than only a 100% hazard free.

---

**IMPORTANT**

Modules should not be pulled under power, nor should a powered RTB be removed, in a Class I Division 2 environment.

---

## CE/CSA/UL/FM Agency Approvals

Any ControlLogix digital I/O modules that have obtained CE/CSA/UL/FM agency approval are marked as such. Ultimately, all digital modules will have these agency approvals and be marked accordingly.

## Using Features Specific to Standard Input Modules

These features are common to all ControlLogix digital input modules:

### Data Transfer on Either Change of State or Cyclic Time

Your ControlLogix input module will send data in one of two ways:

- **Requested Packet Interval** - a user defined rate at which the module updates the information sent to its owner controller. This is also known as Cyclic Data Transfer.
- **Change of State** - configurable feature that, when enabled, instructs the module to update its owner controller with new data whenever a specified input point transitions from ON to OFF or OFF to ON. The data will be sent at the RPI rate. By default, this setting is always enabled for input modules.

For a more detailed explanation of these features, see page 2-10.

### Software Configurable Filter Times

ON to OFF and OFF to ON filter times can be adjusted through RSLogix 5000 software for all ControlLogix input modules. These filters improve noise immunity within a signal. A larger filter value affects the length of delay times for signals from these modules.

For an example of how to set filter times, see pages 6-12.

## Isolated and Non-Isolated Varieties of Modules

ControlLogix input modules provide isolated or non-isolated wiring options. Some applications require power for the I/O circuits to originate on separate, isolated, power sources. Because these conditions require separate commons for each channel, some input modules use individual isolation, or point-to-point isolation.

Other types of isolation available with ControlLogix input modules are channel-to-channel isolation and no isolation. Your application determines what type of isolation is necessary and which input module to use.

## Multiple Point Densities

ControlLogix input modules use either 8, 16, or 32 point densities for greater flexibility in your application.

## Using Features Specific to Standard Output Modules

The following features are common to all ControlLogix standard digital output modules:

### Configurable Point-Level Output Fault States

Individual outputs can be independently configured to unique fault states, either ON, OFF or Last State in case of a communications failure or program mode.

---

**IMPORTANT**

Whenever you inhibit an output module, it enters the program mode and all outputs change to the state configured for the program mode.

For example, if an output module is configured so that the state of the outputs turn off during program mode, whenever that module is inhibited, the outputs will turn off.

---

## Output Data Echo

During normal operation, when a processor sends an output command out to the ControlLogix system, the output module that is targeted for that command will return the commanded state of the output to the system to verify the module received the command and will try to execute it.

Other devices can use this broadcast signal (via a listen-only connection) to determine the desired state of the output without having to interrogate the owner controller.

### *Monitor Fault Bits*

The Output Data Echo only matches the commanded state of the outputs if the module is operating under normal conditions. If there is a problem with the module, the commanded state and the Output Data Echo may not match.

You can monitor the fault bits for your output points for fault conditions. If a fault occurs, the fault bit is set and your program alerts you to the condition. In this case, the output data echo may not match the commanded state of the outputs.

If there is a mismatch between the commanded state of the outputs and the Output Data Echo, check your output module for the following conditions:

- Communications fault
- Connection is inhibited
- Blown fuse - Module will not turn ON output if overload/short circuit is detected.
- Loss of field power (1756-OA8D and 1756-OA8E only) - Module will not turn ON output if no AC power is detected.

## Field Wiring Options

As with input modules, ControlLogix output modules provide isolated or non-isolated wiring options. I/O modules provide point-to-point, group-to-group, or channel-to-channel wiring isolation. Your specific application will determine what type of isolation is necessary and which output module to use.

---

**IMPORTANT**

Although some ControlLogix I/O modules provide non-isolated field side wiring options, each I/O module maintains internal electrical isolation between the system side and field side.

---

## Multiple Point Densities

ControlLogix output modules use either 8, 16, or 32 point densities for greater flexibility in your application.

## Fusing

Some digital outputs have internal electronic or mechanical fusing to prevent too much current from flowing through the module. This feature protects the module from electrical damage. Other modules require external fusing.

Reset an electronic fuse through RSLogix 5000 configuration software or through ladder logic running on a controller. For an example of how to reset an electronic fuse, see page 6-22.

---

**IMPORTANT**

Electronic fuses are also reset through a software reset or when the output module is power cycled.

---

The following modules use electronic fusing:

- 1756-OA8E
- 1756-OB16E
- 1756-OB8EI
- 1756-OV16E

See Table 3.A to determine what fuse to use in your application.

**Table 3.A**  
**Recommended Fuses**

Circuit Type	Catalog Number	Fusing on the Module	Recommended Fuse	Fuse Supplier
AC	1756-OA8 <sup>1</sup>	None - Fused IFM is recommended to protect outputs (See publication 1492-2.12)	5x20mm 6.3A Medium lag	SAN-O Industry Corp. (SOC) p/n MT 4-6.3A
	1756-OA8E <sup>2, 3</sup>	Yes - Fused on a per point basis	Electronically fused	
	1756-OA16 <sup>1, 4, 5</sup>	Yes - Fused on a per group basis	5x20mm 3.15A Slo-Blow 1500A Interruption current	Littlefuse p/n H2153.15
	1756-OA16I <sup>1</sup>	None - Fused IFM is recommended to protect outputs (See publication 1492-2.12)	5x20mm 6.3A Medium lag	SOC p/n MT 4-6.3A
	1756-ON8	None - Fused IFM is recommended to protect outputs (See publication 1492-2.12)	5x20mm 6.3A Medium lag	SOC p/n MT 4-6.3A
DC	1756-OB8 <sup>6</sup>	None - Fused IFM is recommended to protect outputs (See publication 1492-2.12)	5x20mm 4A Quick acting	SOC p/n MQ2-4A
	1756-OB8EI <sup>2, 3, 6</sup>	Yes - Fused on a per point basis	Electronically fused	
	1756-OB16E <sup>2, 3, 6</sup>	Yes - Fused on a per group basis	Electronically fused	
	1756-OB16I <sup>6, 7</sup>	None - Fused IFM is recommended to protect outputs (See publication 1492-2.12)	5x20mm 4A Quick acting	SOC p/n MQ2-4A

**Table 3.A**  
**Recommended Fuses**

Circuit Type	Catalog Number	Fusing on the Module	Recommended Fuse	Fuse Supplier
DC	1756-OB32 <sup>6, 7</sup>	None - Fused IFM is recommended to protect outputs (See publication 1492-2.12)	5x20mm 800mA	Littelfuse p/n SP001.1003 or Schurter p/n 216.800
	1756-OC8 <sup>6</sup>	None - Fused IFM is recommended to protect outputs (See publication 1492-2.12)	5x20mm 4A Quick acting	SOC p/n MQ2-4A
	1756-OH8 <sup>6, 7</sup>	None - Fused IFM is recommended to protect outputs (See publication 1492-2.12)	5x20mm 4A Quick acting	SOC p/n MQ2-4A
	1756-OV16E <sup>2, 3, 6</sup>	Yes - Fused on a per group basis	Electronically fused	
Relay	1756-OW16 <sup>7</sup>	None - Fused IFM is recommended to protect outputs (See publication 1492-2.12)	5x20mm 6.3A Medium lag	SOC p/n MT 4-6.3A
	1756-OX8 <sup>7</sup>	None - Fused IFM is recommended to protect outputs (See publication 1492-2.12)	5x20mm 6.3A Medium lag	SOC p/n MT 4-6.3A

1. For voltages above 132V ac, the Interface Modules (IFM) are not an acceptable means to provide external fusing. A rated terminal block for the intended application must be used.
2. Electronic protection is not intended to replace fuses, circuit breakers, or other code required wiring protection devices.
3. The electronic protection of this module has been designed to provide protection for the module from short circuit conditions. The protection is based on a thermal cut-out principle. In the event of a short circuit condition on an output channel, that channel will limit the current within milliseconds after its thermal cut-out temperature has been reached. All other channels with a NUT of that group will continue to operate as directed by the module master (CPU, Bridge, etc.)
4. A fuse is provided on each common of this module for a total of 2 fuses. The fuses are designed to protect the module from short circuit conditions. The fuse does not provide overload protection. In the event of an overload on an output channel, it is likely that the fuse will not blow and the output device associated with that channel will be damaged. To provide overload protection for your application, user supplied fuses should be externally installed.
5. If a short circuit condition occurs on any channel within this module's group, the entire group is turned off.
6. The module does not provide protection against reverse polarity wiring or wiring to AC power sources.
7. The recommended fuse for this module has been sized to provide short circuit protection for wiring only to external loads. In the event of a short circuit on an output channel, it is likely that the transistor or relay associated with that channel will be damaged and the module should be replaced or a spare output channel used for the load. The fuse does not provide overload protection. In the event of an overload on an output channel, it is likely that the fuse will not blow and the transistor or relay associated with that channel will be damaged. To provide overload protection for your application, user supplied fuse should be installed externally and properly sized to match the individual load characteristics.

## Field Power Loss Detection

The Field Power Loss detection feature is found on the following standard output module:

- 1756-OA8E

When field power to the module is lost, or zero cross cannot be detected, a point level fault is sent to the controller to identify the exact point faulted.

---

**IMPORTANT**

Only enable Field Power Loss detection for points that are in use. If this feature is enabled for points that are not in use, you will receive faults for those points during operation.

---

For an example of how to enable Field Power Loss detection, see page 6-14.

## Diagnostic Latch of Information

The Diagnostic Latch of Information feature is found on the following standard output module:

- 1756-OA8E

Diagnostic Latching allows this module to latch a fault in the set position once it has been triggered, even if the error condition causing the fault to occur disappears.

Latched diagnostic features can be cleared by the Reset Diagnostic Latch service. For an example of how to enable or reset diagnostic latches, see page 6-14.

---

**IMPORTANT**

Diagnostic latches are also reset through a software reset or when the I/O module's power is cycled.

---



## Fault and Status Reporting Between Output Modules and Controller

ControlLogix digital output modules multicast fault/status data to any owner/listening controllers.

All output modules maintain a Module Fault Word, the highest level of fault reporting. Some modules also use additional words to indicate fault conditions, as shown on the next page.

The following tags can be examined in ladder logic to indicate when a fault has occurred:

- **Module Fault Word** - This word provides fault summary reporting. Its tag name is Fault. This word is available on all digital output modules.
- **Fuse Blown Word** - This word indicates a point/group fuse blown on the module. Its tag name is FuseBlown. This word is only available on 1756-OA16, 1756-OA8E, 1756-OB16E, 1756-OB8EI and 1756-OV16E modules.

For more information on fusing, see page 3-14.

- **Field Power Loss Word** - This word indicates a loss of field power to a point on the module. Its tag name is FieldPwrLoss. This word is only available on 1756-OA8E module.

For more information on field power loss, see page 3-17.

All words are 32 bit, although only the number of bits appropriate for each module's density are used. For example, the 1756-OB8 module has a Module Fault Word of 32 bits. But, because the module is an 8 point module, only the first 8 bits (bits0-7) are used in the Module Fault Word.

Fault bits in the Fuse Blown Word, Field Power Loss Word, No Load Word and Output Verify Word are logically ORed into the Module Fault Word. In other words, depending on the module type, a bit set in the Module Fault Word can mean multiple things. It can indicate:

- A communications fault - In this case, all 32 bits are set to 1, regardless of the module's density.
- A fuse blown condition - In this case, only the bit affected is set to 1.
- A field power loss condition - In this case, only the bit affected is set to 1.
- A no load condition - In this case, only the bit affected is set to 1.
- An output verify condition - In this case, only the bit affected is set to 1.

The following graphic provides an overview of the fault reporting process on ControlLogix digital output modules.

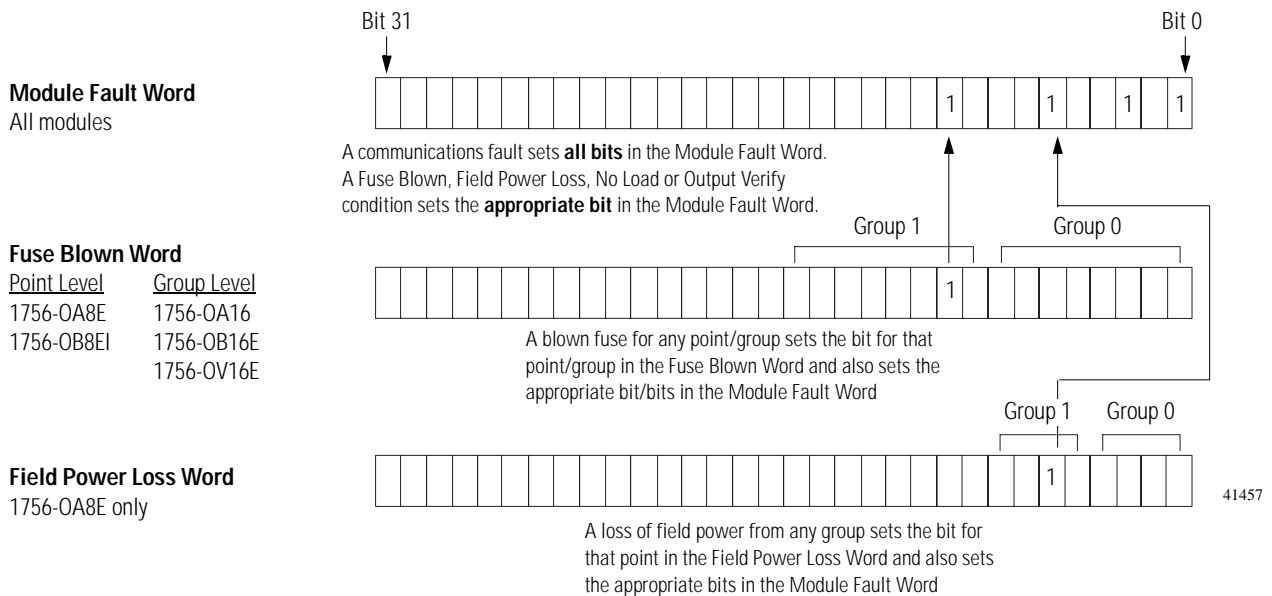

## Chapter Summary and What's Next

In this chapter you learned about:

- determining input module compatibility
- determining output module compatibility
- using features common to ControlLogix standard digital I/O modules
- using features specific to ControlLogix standard digital input modules
- using features specific to ControlLogix standard digital output modules

Move to Chapter 4, ControlLogix Diagnostic Digital I/O Module Features.

## Notes:

## ControlLogix Diagnostic Digital I/O Module Features

**What This Chapter Contains** This chapter describes devices compatible with ControlLogix I/O and features that are specific to various modules.

For information about:	See page:
Determining Diagnostic Input Module Compatibility	4-1
Determining Diagnostic Output Module Compatibility	4-2
Using Features Common to ControlLogix Diagnostic Digital I/O Modules	4-3
Using Features Specific to Diagnostic Input Modules	4-14
Using Features Specific to Diagnostic Output Modules	4-17
Fault and Status Reporting Between Input Modules and Controllers	4-25
Fault and Status Reporting Between Output Modules and Controller	4-27
Chapter Summary and What's Next	4-29

### Determining Diagnostic Input Module Compatibility

ControlLogix digital input modules interface to sensing devices and detect whether they are ON or OFF.

ControlLogix input modules convert ac or dc ON/OFF signals from user devices to appropriate logic level for use within the processor. Typical input devices include:

- proximity switches
- limit switches
- selector switches
- float switches
- pushbutton switches

When designing a system using ControlLogix input modules, you must consider:

- the voltage necessary for your application
- whether you need a solid state device
- current leakage
- if your application should use sinking or sourcing wiring.

For more information on compatibility of other Allen-Bradley Company products to ControlLogix input modules, see the I/O Systems Overview, publication CIG-2.1.

## Determining Diagnostic Output Module Compatibility

ControlLogix output modules may be used to drive a variety of output devices. Typical output devices compatible with the ControlLogix outputs include:

- motor starters
- solenoids
- indicators

When designing a system:

- make sure that the ControlLogix outputs can supply the necessary surge and continuous current for proper operation.
- make sure that the surge and continuous current are not exceeded. Damage to the module could result.

When sizing output loads, check the documentation supplied with the output device for the surge and continuous current needed to operate the device.

The ControlLogix outputs are capable of directly driving the ControlLogix inputs. The exceptions are the ac and dc diagnostic input modules. When diagnostics are used a shunt resistor is required for leakage current.

For more information on the compatibility of motor starters to ControlLogix output modules, see Appendix D.

For more information on compatibility of other Allen-Bradley Company products to ControlLogix output modules, see the I/O Systems Overview, publication CIG-2.1.

## Using Features Common to ControlLogix Diagnostic Digital I/O Modules

The following features are common to all ControlLogix diagnostic digital I/O modules:

### Removal and Insertion Under Power (RIUP)

All ControlLogix I/O diagnostic modules may be inserted and removed from the chassis while power is applied. This feature allows greater availability of the overall control system because, while the module is being removed or inserted, there is no additional disruption to the rest of the controlled process.

### Module Fault Reporting

ControlLogix diagnostic digital I/O modules provide both hardware and software indication when a module fault has occurred. Each module's LED fault indicator and RSLogix 5000 will graphically display this fault and include a fault message describing the nature of the fault.

This feature allows you to determine how your module has been affected and what action should be taken to resume normal operation.

### Fully Software Configurable

The RSLogix 5000 software uses a custom, easily understood interface to write configuration. All module features are enabled or disabled through the I/O configuration portion of the software.

You can also use the software to interrogate any module in the system to retrieve

- serial number
- revision information
- catalog number
- vendor identification
- error/fault information
- diagnostic counters.

By eliminating such tasks as setting hardware switches and jumpers, the software makes module configuration easier and more reliable.

## Electronic Keying

Instead of plastic mechanical backplane keys, electronic keying allows the ControlLogix system to control what modules belong in the various slots of a configured system.

During module configuration, you must choose one of the following keying options for your I/O module:

- Exact Match
- Compatible Match
- Disable Keying

The options above are described later in this section.

When the controller attempts to connect to and configure an I/O module (e.g. after program download), the module compares the following parameters before allowing the connection and configuration to be accepted:

- Vendor
- Product Type
- Catalog Number
- Major Revision
- Minor Revision

The comparison is made between the keying information present in the I/O module and the keying information in the controller's program. This feature can prevent the inadvertent operation of a control system with the wrong module in the wrong slot.

### *Exact Match*

All of the parameters listed above must match or the inserted module will reject a connection to the controller.

### *Compatible Match*

The Compatible Match mode allows an I/O module to determine whether it can emulate the module defined in the configuration sent from the controller.

With ControlLogix digital I/O modules, the module can emulate older revisions. The module will accept the configuration if the configuration's major.minor revision is less than or equal to the physical module's revision.

For example, if the configuration contains a major.minor revision of 2.7, the module inserted into the slot must have minor revision of 2.7 or higher for a connection to be made.

#### TIP



We recommend using Compatible Match whenever possible. Remember, though, the module will only work to the level of the configuration.

For example, if a slot is configured of a module with major.minor revision of 2.7 and you insert a module with a major.minor revision of 3.1, the module works at the 2.7 level despite having been previously upgraded.

If possible, we suggest you make sure configuration is updated to match the revision levels of all I/O modules. Failure to do so may not prevent the application from working but may defeat the purpose of upgrading your modules' revision levels.

### *Disable Keying*

The inserted module attempts to accept a connection to the controller regardless of its type.

---

**ATTENTION**

Be extremely cautious when using the disable keying option; if used incorrectly, this option can lead to personal injury or death, property damage or economic loss.

---

If keying is disabled, a controller makes a connection with most modules of the same type as that used in the slot configuration. For example, if a slot is configured for a 1756-IA16I (standard input module), and a 1756-IB16 (standard input module) is inserted into the slot, the controller established a connection because keying is disabled.

A controller will not establish a connection if any of the following conditions exist, even if keying is disabled:

- The slot is configured for one module type (e.g. input module) and a module of another type (e.g. output module) is inserted in the slot.
- The module inserted into the slot cannot accept some portion of the configuration. For example, if a standard input module is inserted into a slot configured for a diagnostic input module, the controller cannot make a connection because the module cannot accept/process the diagnostic configuration.

## Using the System Clock to Timestamp Inputs and Schedule Outputs

Controllers generate a 64-bit Coordinated System Time (CST) for their respective chassis. The CST is a chassis-specific time that is not synchronized with, or in any way connected to, the time generated over ControlNet to establish a NUT, as described in Chapter 2.

You can configure your digital input modules to access the CST and **full diagnostic input data** with a relative time reference (i.e. the value of the CST) of when that input data changes state.

---

**IMPORTANT**

Because only one CST value is returned to the controller when any input point changes state, it is recommended that you use timestamping on only one input point per module.

---

### *Timestamping for a Sequence of Events*

The CST can be used to establish a sequence of events occurring at a particular input module point by timestamping the input data. To determine a sequence of events, you must:

- Set the input module's communications format to: Full diagnostics input data
- Enable Change of state for the input point where a sequence will occur (Disable COS for all other points on the module)

**TIP**

If you decide to configure multiple input points for COS, your module generates a unique CST each time any of those input points change state, as long as the changes do not occur within 500 $\mu$ S of each other.

If multiple input points configured for COS change state within 500 $\mu$ s of each other, a single CST value is generated for all, making it appear that they changed at exactly the same time.

### *Timestamping In Conjunction with Scheduled Outputs*

Timestamping can be used in conjunction with the **full diagnostics scheduled outputs** feature so that after input data changes state and a timestamp occurs, an output point will actuate at some configured time in the future. You can schedule outputs up to 16 seconds into the future.

When you use timestamping of inputs and scheduled outputs, you must:

- choose a Communications Format for each diagnostic input and diagnostic output module that allows timestamping. For more information on choosing a Communications Format, see Chapter 6.
- have a controller in the same rack as both I/O modules
- disable Change of State for all input points on the input module except the point being timestamped

**TIP**

For scheduled outputs to work most effectively, remember the following:



- The time to schedule outputs to transition in the future must account for any controller, backplane and network delays.
- The I/O modules must reside in the same rack as the timemaster.

For a detailed example of how to write ladder logic to use these features, see Appendix B.

### *Module Major Revision Considerations with Timestamping*

When using timestamping for inputs or diagnostic timestamping of I/O modules, remember the following conditions that may occur depending on the module's Major Revision:

- If the module has a Major Revision = 1, it will always return a positive timestamping value.
- If the module has a Major Revision  $\geq 2$ , it will return a negative timestamping value until the module is synchronized with the owner-controller and the first Change of State condition occurs.

Look at the Module Properties page of RSLogix 5000 to determine if the module has been synchronized with the owner-controller and whether the controller is synchronized with the CST.

For more information on synchronizing owner-controllers and modules with the CST, see the ControlLogix System User Manual, publication 1756-UM001.

### **Producer/Consumer Model**

By using the Producer/Consumer model, ControlLogix I/O modules can produce data without having been polled by a controller first. The modules produce the data and any other owner controller device can decide to consume it.

For example, a diagnostic input module produces data and any number of processors can consume the data at the same time. This eliminates the need for one processor to send the data to another processor. For a more detailed explanation of this process, see Chapter 2.

## LED Status Information

Each ControlLogix diagnostic digital I/O module has an LED indicator on the front of the module that allows you to check the module health and operational status of a module. The LED displays vary for each module.

The following status can be checked with the LED indicators:

- **I/O status** - This yellow display indicates the ON/OFF state of the field device.

---

**IMPORTANT**

For the 1756-OA8D and 1756-OA8E modules, the I/O status indicator does not illuminate without field power applied.

---

- **Module status** - This green display indicates the module's communication status.
- **Fault status** - This display is only found on some modules and indicates the presence or absence of various faults.
- **Fuse status** - This display is only found on electronically fused modules and indicates the state of the module's fuse.

For examples of LED indicators on ControlLogix digital I/O modules, see Chapter 7.

## Full Class I Division 2 Compliance

All ControlLogix digital I/O modules maintain CSA Class I Division 2 system certification. This allows the ControlLogix system to be placed in an environment other than only a 100% hazard free.

---

**IMPORTANT**

Modules should not be pulled under power, nor should a powered RTB be removed, in a Class I Division 2 environment.

---

## CE/CSA/UL/FM Agency Approvals

Any ControlLogix digital I/O modules that have obtained CE/CSA/UL/FM agency approval are marked as such. Ultimately, all digital modules will have these agency approvals and be marked accordingly.

## Diagnostic Latch of Information

Diagnostic Latching allows diagnostic I/O modules to latch a fault in the set position once it has been triggered, even if the error condition causing the fault to occur disappears.

Latched diagnostic features can be cleared by the Reset Diagnostic Latch service. For an example of how to enable or reset diagnostic latches, see page 6-14 for diagnostic input modules and page 6-15 for diagnostic output modules.

---

**IMPORTANT**

Diagnostic latches are also reset through a software reset or when the I/O module's power is cycled.

---

## Diagnostic Timestamp

Diagnostic I/O modules can timestamp the time when a fault occurs or when it clears. This feature provides greater accuracy and flexibility in running applications. Modules use the ControlLogix system clock from a local controller to generate timestamps.

To use diagnostic timestamps, you must choose the appropriate Communications Format during initial configuration. For more information on choosing a Communications Format, see Chapter 6.

## 8 Point AC/16 Point DC

Diagnostic ControlLogix digital I/O modules provide various grouping of points on different modules. The 8 point AC modules and 16 point DC modules provide additional flexibility when designing module applications.

### Point Level Fault Reporting

Diagnostic I/O modules set bits to indicate when a fault has occurred on a point-by-point basis. The following fault conditions generate their own unique fault bits:

**Table 4.A**  
**Unique Fault Bits for I/O Points**

	Input Points	Output Points
<b>Conditions Setting a Fault Bit</b>	Open wire Field power loss (1756-IA8D only)	Fuse blown No load Output verify Field power loss (1756-OA8D only)

Using these bits in tandem with “data echo” and manually performing a pulse test can help to further isolate the fault.

See Table 4.B for possible diagnostic faults on the 1756-OA8D module.

**Table 4.B**  
**1756-OA8D Diagnostic Fault Table**

Ladder Commands the Output to be ON:	Ladder Commands Output to be OFF:	Possible Cause of Fault:
<ol style="list-style-type: none"> <li>Output Data Echo returns the state of the output as OFF.</li> <li>Fuse Blown bit is set.</li> </ol>	<ol style="list-style-type: none"> <li>Output Data Echo returns the state of the output as OFF<sup>1</sup>.</li> <li>Pulse Test fails.</li> </ol>	Output is shorted to L2
<ol style="list-style-type: none"> <li>Output Data Echo returns the state of the output as ON.</li> <li>Pulse Test fails.<sup>2</sup></li> </ol>	<ol style="list-style-type: none"> <li>Output Data Echo returns the state of the output as OFF.</li> <li>No Load bit is set.</li> </ol>	No Load or output is shorted to L1

**Table 4.B**  
**1756-OA8D Diagnostic Fault Table**

Ladder Commands the Output to be ON:	Ladder Commands Output to be OFF:	Possible Cause of Fault:
<ol style="list-style-type: none"> <li>Output Data Echo returns the state of the output as OFF.</li> <li>No Load shows a Fault.</li> <li>Field Power Loss shows a Fault.</li> <li>Pulse Test fails.</li> </ol>	<ol style="list-style-type: none"> <li>Output Data Echo returns the state of the output as OFF.</li> <li>No Load bit is set.</li> <li>Field Power Loss bit is set.</li> <li>Pulse Test fails.</li> </ol>	L1 or L2 are disconnected or outside the 47-63Hz frequency range
<ol style="list-style-type: none"> <li>Output Data Echo returns the state of the output as ON<sup>3</sup>.</li> <li>Output Verify<sup>4</sup> bit is set.</li> </ol>	<ol style="list-style-type: none"> <li>Output Data Echo returns the state of the output as OFF.</li> <li>Pulse Test fails.</li> </ol>	Hardware point damage <sup>5</sup>

- It is not possible to create a fuse blown fault in the OFF state. If a short circuit occurs, the output point is turned OFF and the fault appears in the OFF state until the point is reset.
- When pulse test is executed, it is normal operation to see a momentary pulsation on the module display.
- The output cannot turn ON due to hardware point damage.
- Depending on the characteristics of an applied short circuit, an output verify fault could be set until the short circuit is detected by the module and the output is turned OFF.
- During normal operating conditions, hardware damage should not be possible. An output shorted to L2 may temporarily cause a hardware point fault. See output shorted to L2 as a possible cause.

See Table 4.C for possible diagnostic faults on the 1756-OB16D module

**Table 4.C**  
**1756-OB16D Diagnostic Fault Table**

Ladder Commands the Output to be ON:	Ladder Commands the Output to be OFF:	Possible Cause of Fault:
<ol style="list-style-type: none"> <li>Output Data Echo returns the state of the output as OFF.</li> <li>Fuse Blown<sup>1</sup> bit is set.</li> </ol>	<ol style="list-style-type: none"> <li>Output Data Echo returns the state of the output as OFF<sup>2</sup>.</li> <li>Pulse Test fails<sup>3</sup>.</li> </ol>	Output is shorted to GND
<ol style="list-style-type: none"> <li>Output Data Echo returns the state of the output as ON.</li> <li>Pulse Test fails.</li> </ol>	<ol style="list-style-type: none"> <li>Output Data Echo returns the state of the output as OFF.</li> <li>No Load bit is set.</li> <li>Pulse Test passes.</li> </ol>	One of the following: <ol style="list-style-type: none"> <li>No Load</li> <li>Output is shorted to DC+</li> <li>No power to the module</li> </ol>
<ol style="list-style-type: none"> <li>Output Data Echo returns the state of the output as ON<sup>4</sup>.</li> <li>Output Verify<sup>5</sup> sets a bit.</li> </ol>	<ol style="list-style-type: none"> <li>Output Data Echo returns the state of the output as OFF.</li> <li>Pulse Test fails.</li> </ol>	Hardware point damage <sup>6</sup>

- The electronic protection of this module has been designed to provide protection for the module from short circuit conditions. The protection is based on a thermal cutout principal. In the event of a short circuit condition on an output channel, that channel will limit the current within milliseconds after its thermal cutout temperature has been reached. Other channels could produce a false error on the output verify fault signal due to the supply dropping below the minimum detect level of 19.2V dc. The output channels that are affected by this phenomena will continue to operate as directed by the module master (CPU, Bridge, etc.) What this means is that the output verify fault signals of the other channels should be checked and reset if a short circuit on one channel occurs.
- It is not possible to create a fuse blown fault in the OFF state. If a short circuit occurs, the output point is turned OFF and the fault appears in the OFF state until that point is reset.
- When pulse test is executed, it is normal operation to see a momentary pulsation on the module display.
- The output cannot turn ON due to hardware point damage.
- Depending on the characteristics of an applied short circuit, an output verify fault could be set until the short circuit is detected by the module and the output is turned OFF.
- During normal operating conditions, hardware damage should not be possible. An output shorted to GND may temporarily cause a hardware point fault. See output shorted to GND as a possible cause.

## Using Features Specific to Diagnostic Input Modules

The following features are available on all ControlLogix diagnostic digital input modules:

### Data Transfer on Either Change of State or Cyclic Time

Your ControlLogix input module will send data in one of two ways:

- **Requested Packet Interval** - a user defined rate at which the module updates the information sent to its owner controller. This is also known as Cyclic Data Transfer.
- **Change of State** - configurable feature that, when enabled, instructs the module to update its owner controller with new data whenever a specified input point transitions from ON to OFF or OFF to ON. The data will be sent at the RPI rate. The default setting for this feature is always enabled.

For a more detailed explanation of these features, see page 2-10.

### Software Configurable Filter Times

ON to OFF and OFF to ON filter times can be adjusted through RSLogix 5000 software for all ControlLogix diagnostic input modules. These filters improve noise immunity within a signal. A larger filter value affects the length of delay times for signals from these modules.

For an example of how to set filter times, see page 6-14 for diagnostic input modules.

### Isolated and Non-Isolated Varieties of Modules

ControlLogix diagnostic input modules provide isolated or non-isolated wiring options. Some applications require power for the I/O circuits to originate on separate, isolated, power sources. Because these conditions require separate commons for each channel, some input modules use individual isolation, or point-to-point isolation.

Other types of isolation available with ControlLogix diagnostic input modules are channel-to-channel isolation and no isolation. Your specific application will determine what type of isolation is necessary and which input module to use.

## Multiple Point Densities

ControlLogix diagnostic input modules use either 8, 16, or 32 point densities for greater flexibility in your application.

## Open Wire Detection

Open Wire is used to make sure the field wiring is connected to the module. The field device must provide a minimum leakage current to function properly.

A leakage resistor must be placed across the contacts of an input device. (See each module's specifications, listed in Chapter 6, for more details.) The resulting current is then expected to exist when the input is open.

When an Open Wire condition is detected, a point-level fault is sent to the controller to identify the exact point fault. This feature has a corresponding tag that can be examined in the user program in the event of a fault. For more information on these tags, see Appendix A.

---

**IMPORTANT**

If this feature is enabled for points that are not in use, you will receive faults for those points during operation.

---

For an example of how to enable the Open Wire detection diagnostic, see page 6-15.

## Field Power Loss Detection

Field Power Loss is **only** found on the **1756-IA8D** module.

When field power to the module is lost, a point level fault is sent to the controller to identify the exact point faulted. Only enable Field Power Loss detection for points that are in use.

This feature has a corresponding tag that can be examined in the user program in the event of a fault. For more information on these tags, see Appendix A.

---

**IMPORTANT**

If this feature is enabled for points that are not in use, you will receive faults for those points during operation.

---

For an example of how to set the Field Power Loss detection diagnostic, see page 6-14.

## Diagnostic Change of State for Input Modules

If the Diagnostic Change of State feature is enabled, a diagnostic input module sends new data to the owner controller when one of three events occurs:

- **Requested Packet Interval** - a user defined rate at which the module updates the information sent to its owner controller
- **Change of State** - configurable feature that, when enabled, instructs the module to update its owner-controller with new data whenever a specified input point transitions from ON to OFF or OFF to ON. The transitioned input data is sent with the next RPI update.
- **Diagnostic Change of State** - any change in the diagnostics for a particular input point

Although the RPI occurs continuously, this COS feature allows you to decide whether changes in a module's diagnostic detection should cause the module to send real time data to the owner controller.

If this feature is enabled, the input module sends new data to the owner controller at the RPI, on input COS if it is enabled, and if a diagnostic fault occurs.

If this feature is disabled, real time data is **not** sent when a diagnostic fault occurs but is still sent at the specified RPI or on input COS if it is enabled.

## Using Features Specific to Diagnostic Output Modules

The following features are common to all ControlLogix diagnostic digital output modules:

### Configurable Point-Level Output Fault States

Individual outputs can be independently configured to unique fault states, either ON, OFF or Last State in case of a communications failure or program mode.

---

**IMPORTANT**

Whenever you inhibit a diagnostic output module, it enters the program mode and all outputs change to the state configured for the program mode.

For example, if an output module is configured so that the state of the outputs turn off during program mode, whenever that module is inhibited, the outputs will turn off.

---

## Output Data Echo

During normal operation, when a processor sends an output command out to the ControlLogix system, the diagnostic output module that is targeted for that command will return the commanded state of the output to the system to verify the module received the command and will try to execute it.

Other devices can use this broadcast signal (via a listen-only connection) to determine the desired state of the output without having to interrogate the owner controller.

This feature cannot relay to the system that the field-side device connected to the output module has executed the command. If your application requires a more detailed response than only acknowledging the receipt of a command, see the **Field Side Output Verification** feature, defined later in this chapter.

### *Monitor Fault Bits*

The Output Data Echo only matches the commanded state of the outputs if the module is operating under normal conditions. If there is a problem with the module, the commanded state and the Output Data Echo may not match.

You can monitor the fault bits for your output points for fault conditions. If a fault occurs, the fault bit is set and your program alerts you to the condition. In this case, the output data echo may not match the commanded state of the outputs.

If there is a mismatch between the commanded state of the outputs and the Output Data Echo, check your diagnostic output module for the following conditions:

- Communications fault
- Connection inhibited
- Blown fuse - Module will not turn ON output if overload/short circuit is detected.
- Loss of field power (1756-OA8D and 1756-OA8E only) - Module will not turn ON output if no AC power is detected.

## Field Wiring Options

As with diagnostic input modules, ControlLogix diagnostic output modules provide isolated or non-isolated wiring options. I/O modules provide point-to-point, group-to-group, or channel-to-channel wiring isolation.

Your specific application determines what type of isolation is necessary and which output module to use.

---

**IMPORTANT**

Although some ControlLogix diagnostic I/O modules provide non-isolated field side wiring options, each I/O module maintains internal electrical isolation between the system side and field side.

---

## Multiple Point Densities

ControlLogix diagnostic output modules use either 8, 16, or 32 point densities for greater flexibility in your application.

## Fusing

Diagnostic digital outputs have internal electronics to prevent too much current from flowing through the module. This feature protects the module from electrical damage.

Reset an electronic fuse through RSLogix 5000 configuration software or through ladder logic running on a controller. For an example of how to reset an electronic fuse, see page 6-22.

### IMPORTANT

Electronic fuses are also reset through a software reset or when the diagnostic output module is power cycled.

**Table 4.D**  
**Recommended Fuses**

Circuit Type	Catalog Number	Fusing on the Module	Recommended Fuse
AC	1756-OA8D <sup>1, 2</sup>	Yes - Fused on a per point basis	Electronically fused
DC	1756-OB16D <sup>1, 2, 3</sup>	Yes - Fused on a per point basis	Electronically fused

1. Electronic protection is not intended to replace fuses, circuit breakers, or other code required wiring protection devices.
2. The electronic protection of this module has been designed to provide protection for the module from short circuit conditions. The protection is based on a thermal cut-out principle. In the event of a short circuit condition on an output channel, that channel will limit the current within milliseconds after its thermal cut-out temperature has been reached. All other channels will continue to operate as directed by the module master (CPU, Bridge, etc.)
3. The electronic protection of this module has been designed to provide protection for the module from short circuit conditions. The protection is based on a thermal cut-out principle. In the event of a short circuit condition on an output channel, that channel will limit the current within milliseconds after its thermal cut-out temperature has been reached. Other channels could produce a false error on the output verify fault signal due to the supply dropping below the minimum detect level of 19.2V dc. The output channels that are affected by this phenomena will continue to operate as directed by the module master (CPU, Bridge, etc.). What this means is that the output verify fault signals of the other channels should be checked and reset if a short circuit on one channel occurs.

## No Load Detection

For each output point, No Load detects the **absence of field wiring or a missing load** from each output point in the **off state only**.

The output circuit on a diagnostic output module has a Current Sense optoisolator used in parallel with the output transistor. Current flows through this sensing circuit only when the output is OFF, as shown in the simplified diagram below.

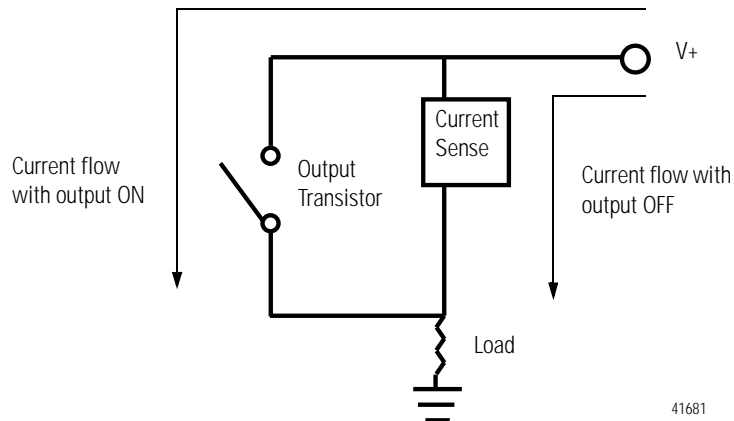

Diagnostic output modules list a minimum load current specification (1756-OA8D = 10mA & 1756-OB16D = 3mA). In the ON-state, the module must be connected to a load which will draw a minimum current equal to these values.

If a connected load is sized in accordance with the minimum load current specification, diagnostic output modules are capable of sensing current through the optoisolator and the load when the output point is OFF.

For an example of how to set the No Load detection diagnostic, see page 6-15.

This feature has a corresponding tag that can be examined in the user program in the event of a fault. For more information on these tags, see Appendix A.

## Field Side Output Verification

Field Side Output Verification informs the user that logic side instructions that the module consumes are accurately represented on the power side of a switching device. In other words, for each output point, this feature confirms that the output is ON when it is commanded to be ON.

The diagnostic output module can tell a controller that it received a command and whether or not the field-side device connected to the module has executed the command. For example, in applications that need to verify that the module has accurately followed the processor's instructions, the module samples the field side state and compares it to the system side state.

This feature has a corresponding tag that can be examined in the user program in the event of a fault. For more information on these tags, see Appendix A.

If an output cannot be verified, a point level fault is sent to the controller. For an example of how to enable the Output Verify diagnostic, see page 6-15.

## Pulse Test

Pulse Test is a feature found on diagnostic output modules that can verify output-circuit functionality without actually changing the state of the output load device. A short pulse is sent to the targeted output circuit. The circuit should respond as it would if a real change-of-state command was issued, but the load device does not transition.

**TIP**

Consider the following when using the Pulse Test:

- Only use the test when the output state does not transition for long periods of time. Normal diagnostics will catch faults if the outputs are transitioning regularly.
- When first performing the pulse test, it is recommended that you verify the load will not transition. You should be at the actual load while the test is performed.

The Pulse Test can be used to perform a preemptive diagnosis of possible future module conditions. For example, you can use Pulse Test to:

- detect a blown fuse before it happens.

The Blown Fuse diagnostic (see page 4-20 for a complete explanation of fusing) can only be used when an output module is in the ON state. But it would be useful to be made aware when operating conditions for a module may cause a blown fuse.

If you perform a pulse test on the module while the output is in the OFF state, the output point is commanded to be ON briefly, as described above. Although no diagnostic bits are set in the output data echo, the pulse test will report a failure because conditions when the point is ON indicate a blown fuse condition may occur (see pages 4-12 & 4-13).

---

**IMPORTANT**

The Pulse Test does not guarantee a fuse will blow when the output point turns on. It merely indicates this condition is possible.

---

- detect a No Load condition with an output ON.

The No Load diagnostic (see page 4-21 for a complete explanation) can only detect a fault (i.e. set the No Load bit) when an output point is in the OFF state. But you may find it useful to be made aware when operating conditions for that point may reveal a potential No Load condition.

If you perform a pulse test on an output point while it is in the ON state, the output point is commanded to be OFF briefly, as described on page 4-22. The pulse test will report a failure because conditions when the point is OFF indicate the possible absence of a field device; in this case, though, the No Load bit will not be set (see pages 4-12 & 4-13).

---

**IMPORTANT**

The Pulse Test does not guarantee the absence of a load. It merely indicates this condition is possible.

---

Pulse Test is a service that needs to be executed from an RSLogix 5000 program or the module properties page, using the pulse test tab and should be verified with your load to make sure that there are no false transitions.

For an example of how to perform a Pulse Test using ladder logic, see page B-13.

## Point Level Electronic Fusing

Diagnostic output modules use electronic fusing to protect output points from the surge of too much current through that point on the module. If too much current begins to flow through a point, the fuse is tripped and a point level fault is sent to the controller.

Reset an electronic fuse through RSLogix 5000 configuration software or through ladder logic running on a controller. This feature has a corresponding tag that can be examined in the user program in the event of a fault. For more information on these tags, see Appendix A.

For an example of how to reset an electronic fuse in RSLogix 5000, see page 6-22. For an example of how to reset an electronic fuse using a ladder logic program, see page B-13.

---

**IMPORTANT**

Electronic fuses are also reset through a software reset or when the output module is power cycled.

---

## Field Power Loss Detection

This feature is used when field power to the module is lost or zero cross cannot be detected. A point level fault is sent to the controller to identify the exact point faulted.

---

**IMPORTANT**

Only enable Field Power Loss detection for points that are in use. If this feature is enabled for points that are not in use, you will receive faults for those points during operation.

---

This feature has a corresponding tag that can be examined in the user program in the event of a fault. For more information on these tags, see Appendix A.

For an example of how to enable the Field Power Loss detection diagnostic, see page 6-14.

## Diagnostic Change of State for Output Modules

Using the Diagnostic Change of State feature, a diagnostic output module sends new data to the owner controller when one of three events occurs:

- **Requested Packet Interval** - user-defined interval for scheduled updates during normal module operation
- **Receipt of Output Data** - an output module echoes data back to the owner controller
- **Diagnostic Change of State** - any change in the diagnostics for a particular output point

Unlike diagnostic input modules, this feature cannot be disabled for diagnostic output modules. If any of the three events described above occurs, the output module sends new data to the owner controller.

## Fault and Status Reporting Between Input Modules and Controllers

ControlLogix diagnostic digital input modules multicast fault/status data to any owner/ listening controllers.

All diagnostic input modules maintain a Module Fault Word, the highest level of fault reporting. Some modules also use additional words to indicate fault conditions, as shown on the next page.

The following tags can be examined in ladder logic to indicate when a fault has occurred:

- **Module Fault Word** - This word provides fault summary reporting. It's tag name is Fault. This word is available on all digital input modules.
- **Field Power Loss Word** - This word indicates loss of field power to a group on the module. It's tag name is FieldPwrLoss. This word is only available on 1756-IA8D.

For more information on field power loss, see page 4-16.

- **Open Wire Word** - This word indicates the loss of a wire from a point on the module. It's tag name is OpenWire.

For more information on open wire, see page 4-15.

All words are 32 bit, although only the number of bits appropriate for each module’s density are used. For example, the 1756-IA16I module has a Module Fault Word of 32 bits. But, because this is a 16 point module, only the first 16 bits (bits 0-15) are used in the Module Fault Word.

Fault bits in the Field Power Loss Word and Open Wire Word are logically ORed into the Module Fault Word. In other words, depending on the module type, a bit set in the Module Fault Word can mean multiple things. It can indicate:

- A communications fault - In this case, all 32 bits are set to 1, regardless of the module’s density.
- A field power loss condition - In this case, only the bit(s) affected is set to 1.
- An open wire condition - In this case, only the bit(s) affected is set to 1.

The following graphic provides an overview of the fault reporting process on ControlLogix digital input modules.

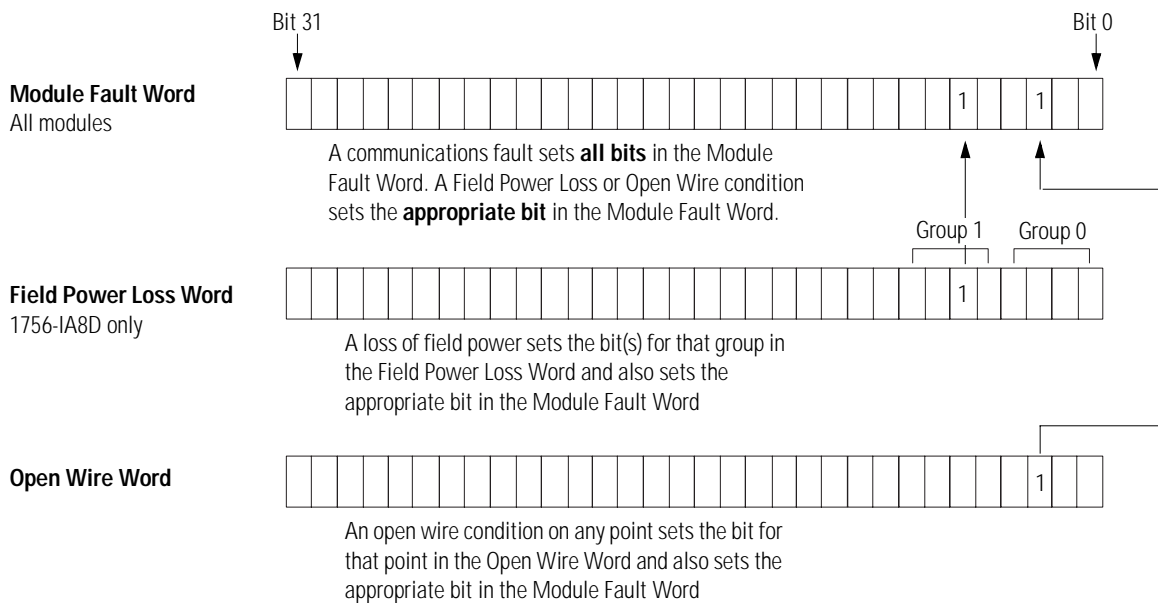

41456

## Fault and Status Reporting Between Output Modules and Controller

ControlLogix diagnostic digital output modules multicast fault/status data to any owner/listening controllers.

All output modules maintain a Module Fault Word, the highest level of fault reporting. Some modules also use additional words to indicate fault conditions, as shown on the next page.

The following tags can be examined in ladder logic to indicate when a fault has occurred:

- **Module Fault Word** - This word provides fault summary reporting. Its tag name is Fault. This word is available on all digital output modules.
- **Fuse Blown Word** - This word indicates a point/group fuse blown on the module. Its tag name is FuseBlown.

For more information on fusing, see page 4-20.

- **Field Power Loss Word** - This word indicates a loss of field power to a point on the module. Its tag name is FieldPwrLoss. This word is only available on 1756-OA8D module.

For more information on field power loss, see page 4-16.

- **No Load Word** - This word indicates a loss of a load from a point on the module. Its tag name is NoLoad.

For more information on no load conditions, see page 4-21.

- **Output Verify Word** - This word indicates when an output is not performing as commanded by the owner controller. Its tag name is OutputVerify.

For more information on output verify, see page 4-22.

All words are 32 bit, although only the number of bits appropriate for each module's density are used. For example, the 1756-OB8 module has a Module Fault Word of 32 bits. But, because the module is an 8 point module, only the first 8 bits (bits0-7) are used in the Module Fault Word.

Fault bits in the Fuse Blown Word, Field Power Loss Word and Output Verify Word are logically ORed into the Module Fault Word. In other words, depending on the module type, a bit set in the Module Fault Word can mean multiple things. It can indicate:

- A communications fault - In this case, all 32 bits are set to 1, regardless of the module's density.
- A fuse blown condition - In this case, only the bit affected is set to 1.
- A field power loss condition - In this case, only the bit affected is set to 1.
- A no load condition - In this case, only the bit affected is set to 1.
- An output verify condition - In this case, only the bit affected is set to 1.

The following graphic provides an overview of the fault reporting process on ControlLogix digital output modules.

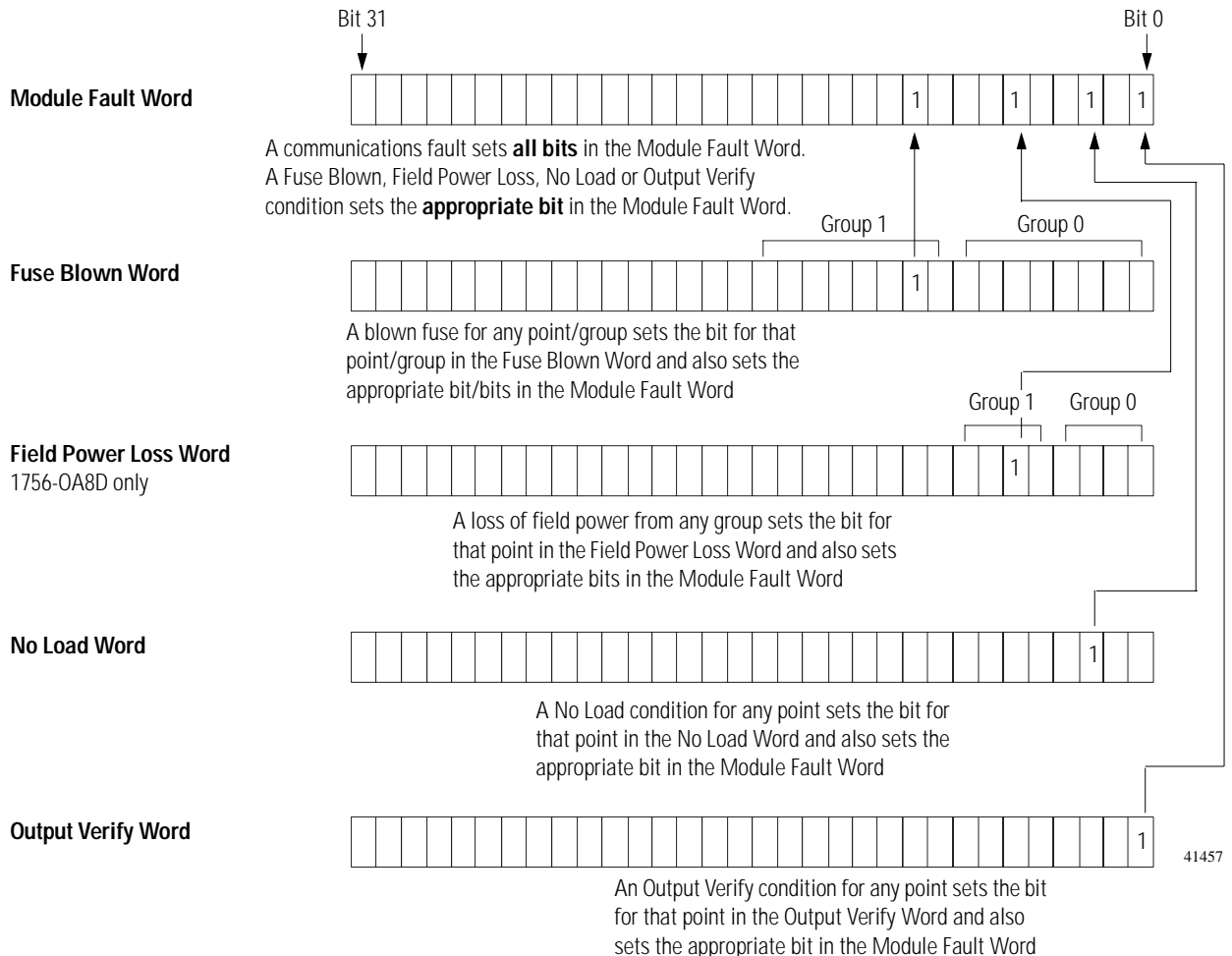

## Chapter Summary and What's Next

In this chapter you learned about:

- determining input module compatibility
- determining output module compatibility
- using features common to ControlLogix diagnostic digital I/O modules
- using features specific to ControlLogix diagnostic digital input modules
- using features specific to ControlLogix diagnostic digital output modules

Move to Chapter 5, Installing the ControlLogix I/O Module.

## Notes:

## Installing the ControlLogix I/O Module

### What This Chapter Contains

This chapter describes how to install ControlLogix modules. The following table describes what this chapter contains and its location.

For information about:	See page:
Installing the ControlLogix I/O Module	5-1
Keying the Removable Terminal Block	5-2
Connecting Wiring	5-4
Assembling The Removable Terminal Block and the Housing	5-7
Installing the Removable Terminal Block	5-10
Removing the Removable Terminal Block	5-12
Removing the Module from the Chassis	5-13
Chapter Summary and What's Next	5-14

### Installing the ControlLogix I/O Module

You can install or remove the module while chassis power is applied.

#### ATTENTION



The module is designed to support Removal and Insertion Under Power (RIUP). However, when you remove or insert an RTB with field-side power applied, **unintended machine motion or loss of process control can occur**. Exercise extreme caution when using this feature.

1. Align circuit board with top and bottom chassis guides.

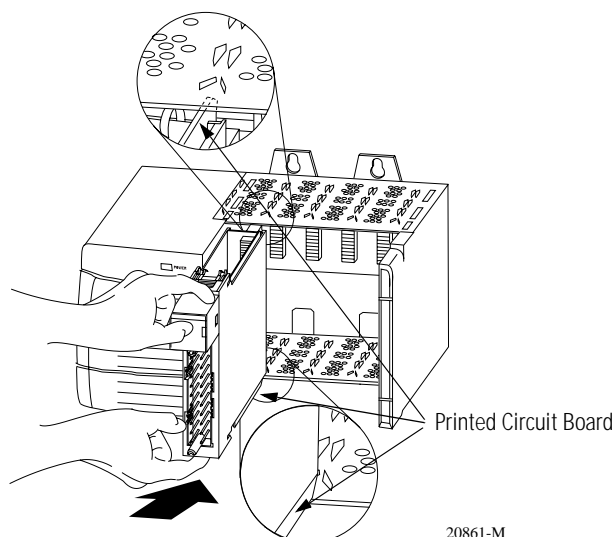

20861-M

2. Slide module into chassis until module tabs 'click'.

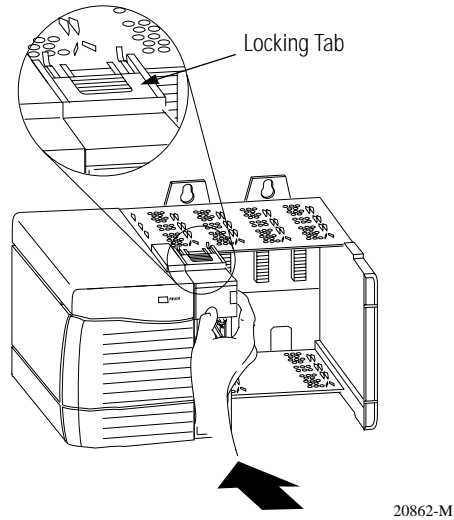

20862-M

## Keying the Removable Terminal Block

Key the RTB to prevent inadvertently connecting the incorrect RTB to your module.

When the RTB mounts onto the module, keying positions will match up. For example, if you place a U-shaped keying band in position #4 on the module, you cannot place a wedge-shaped tab in #4 on the RTB or your RTB will not mount on the module.

We recommend that you use a unique keying pattern for each slot in the chassis.

1. Insert the U-shaped band with the longer side near the terminals. Push the band onto the module until it snaps into place.

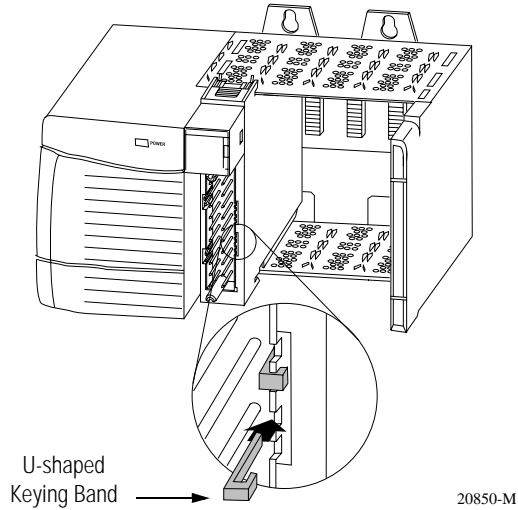

2. Key the RTB in positions that correspond to unkeyed module positions. Insert the wedge-shaped tab on the RTB with the rounded edge first. Push the tab onto the RTB until it stops.

**IMPORTANT**

When keying your RTB and module, you must begin with a wedge-shaped tab in position #6 or #7.

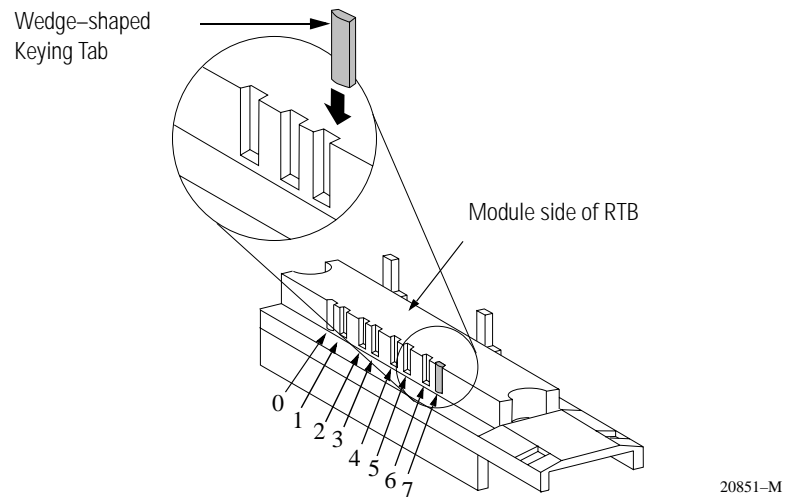

## Connecting Wiring

You can use an RTB or IFM to connect wiring to you module. If you are using an RTB, follow the directions below to connect wires to the RTB. An IFM has been prewired before you received it.

If you are using an IFM to connect wiring to the module, skip this section and move to page 5-10.

### Three Types of RTBs (each RTB comes with housing)

- Cage Clamp - Catalog number 1756-TBCH
- NEMA Clamp - Catalog number 1756-TBNH
- Spring Clamp - Catalog number 1756-TBSH or TBS6H

#### *Cage Clamp*

1. Insert the wire into the terminal.
2. Turn the screw clockwise to close the terminal on the wire.

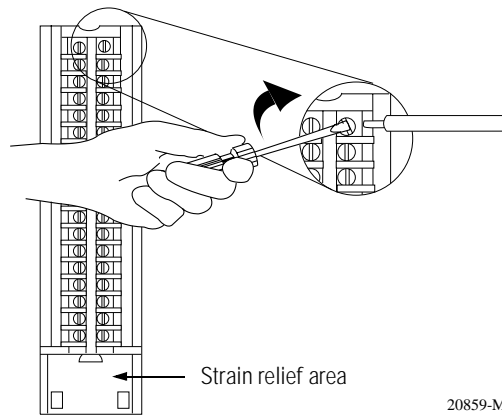

#### *NEMA Clamp*

Terminate wires at the screw terminals.

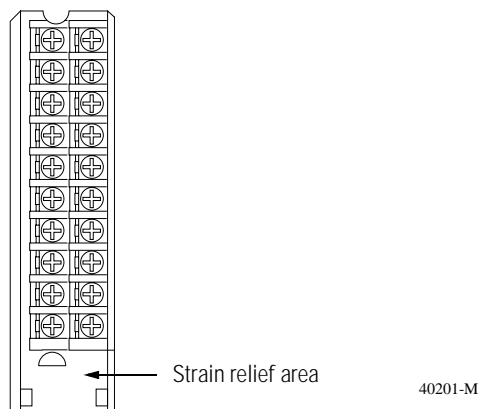

### Spring Clamp

1. Insert the screwdriver into the outer hole of the RTB.
2. Insert the wire into the open terminal and remove the screwdriver.

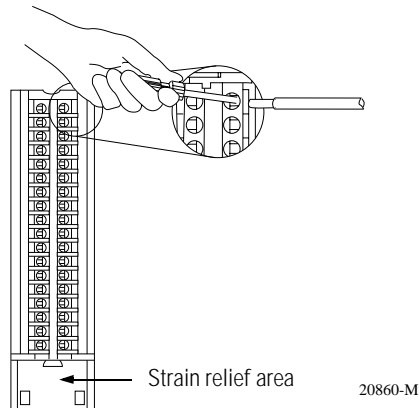

### Recommendations for Wiring Your RTB

Consider the following guidelines when wiring your RTB:

- Begin wiring the RTB at the bottom terminals and move up.
- Use a tie to secure the wires in the strain relief area of the RTB.
- The **jumper bar** part number is 97739201. Contact your local Rockwell Automation sales representative to order additional jumper bars, if necessary.
- Order and use an **extended-depth housing** (Cat. No.1756-TBE) for applications that require heavy gauge wiring. For more information, see page 5-8.

Table 5.A lists the page number of the specific wiring diagram for each ControlLogix I/O module.

**Table 5.A**  
**Wiring Connections**

Catalog Number:	Page for Wiring Connections:	RTB:
1756-IA16	7-2	20 pin
1756-IA16I	7-4	36 pin
1756-IA8D	7-6	20 pin
1756-IB16	7-8	20 pin
1756-IB16D	7-10	36 pin
1756-IB16I	7-12	36 pin
1756-IB32	7-14	36 pin
1756-IC16	7-16	20 pin
1756-IH16I	7-18	36 pin
1756-IM16I	7-20	36 pin
1756-IN16	7-22	20 pin
1756-IV16	7-24	20 pin
1756-IV32	7-26	36 pin
1756-OA16	7-28	20 pin
1756-OA16I	7-30	36 pin
1756-OA8	7-32	20 pin
1756-OA8D	7-34	20 pin
1756-OA8E	7-36	20 pin
1756-OB16D	7-38	36 pin
1756-OB16E	7-40	20 pin
1756-OB16I	7-42	36 pin
1756-OB32	7-44	36 pin
1756-OB8	7-46	20 pin
1756-OB8EI	7-48	36 pin
1756-OC8	7-50	36 pin
1756-OH8I	7-52	36 pin
1756-ON8	7-54	20 pin
1756-OV16E	7-56	20 pin
1756-OW16I	7-58	36 pin
1756-OX8I	7-60	36 pin

## Assembling The Removable Terminal Block and the Housing

Removable housing covers the wired RTB to protect wiring connections when the RTB is seated on the module.

1. Align the grooves at the bottom of each side of the housing with the side edges of the RTB.

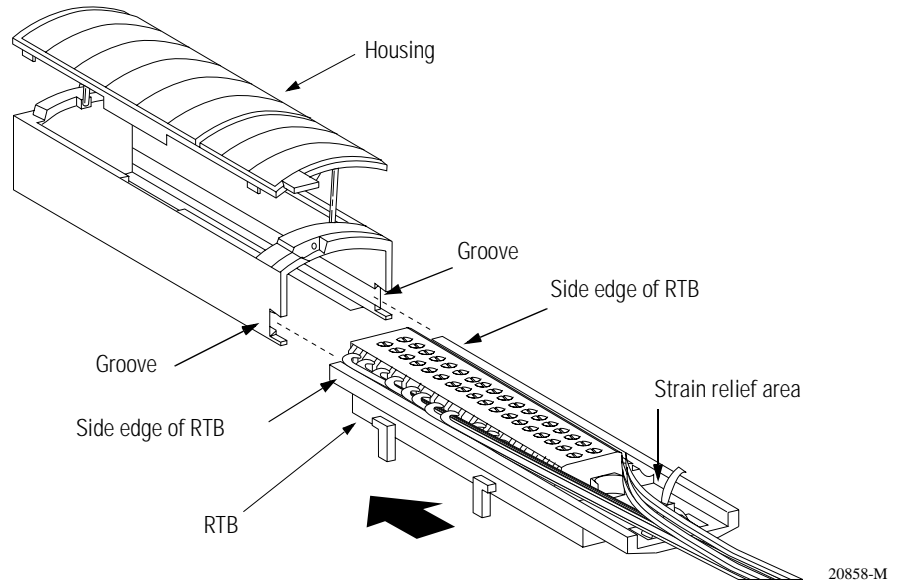

1756-TBCH RTB shown for reference

2. Slide the RTB into the housing until it snaps into place.

### **IMPORTANT**

If additional wire routing space is required for your application, use extended-depth housing 1756-TBE.

## Choosing the Extended-Depth Housing

There are two housing options you must consider when wiring your ControlLogix digital I/O module.

When you order an RTB for your I/O module, you receive a standard-depth housing with the RTB. If your application uses heavy gauge wiring, you can order an extended-depth housing. This housing does not come with an RTB.

You can use one of the following housings:

- **standard-depth housing** - 1756-TBNH, -TBSH, -TBCH, or -TBS6H, included with your RTB order
- **extended-depth housing** - 1756-TBE, must be ordered separately

The graphic below shows the difference, in terms of capacity, between the housing options.

**IMPORTANT**

The housings shown are used with a spring clamp RTB, but the capacity for each remains the same regardless of RTB type.

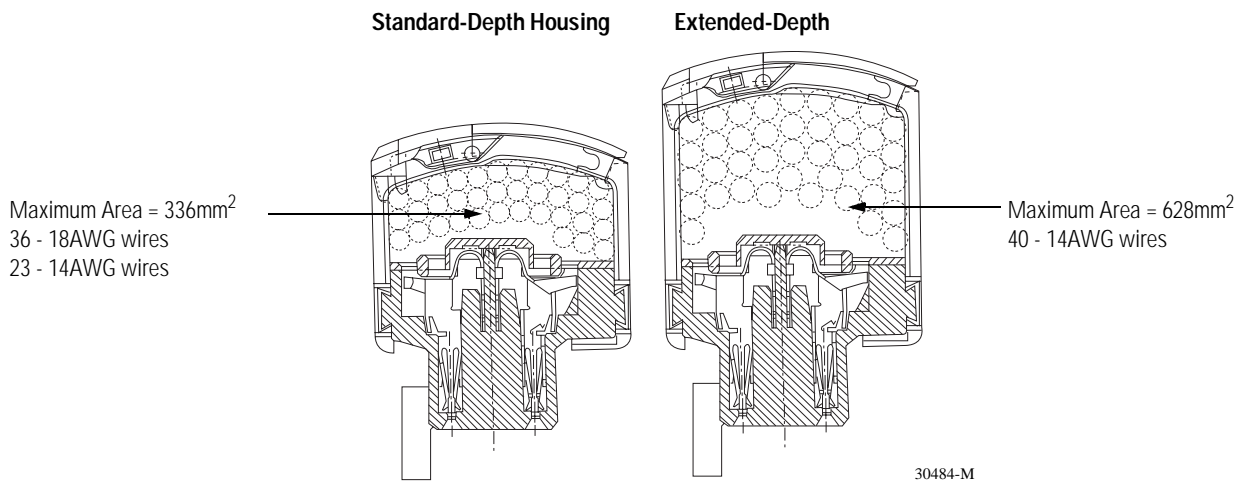

**IMPORTANT**

The housings maintain the following maximum areas:

- standard-depth housing maximum area = 336mm<sup>2</sup>
- extended-depth housing maximum area = 628mm<sup>2</sup>

## Suggestions for Using the Extended-Depth Housing

Consider the following recommendations when deciding to use an extended-depth housing on your I/O module. It is recommended you use the 1756-TBE when:

- using >36 18AWG wires
- using >23 14AWG wires

## Cabinet Size Considerations With the Extended-Depth Housing

When you use an extended-depth housing (1756-TBE), the I/O module depth is increased. The diagram below shows the difference, in terms of depth, between an I/O module using a standard-depth housing and one using an extended-depth housing.

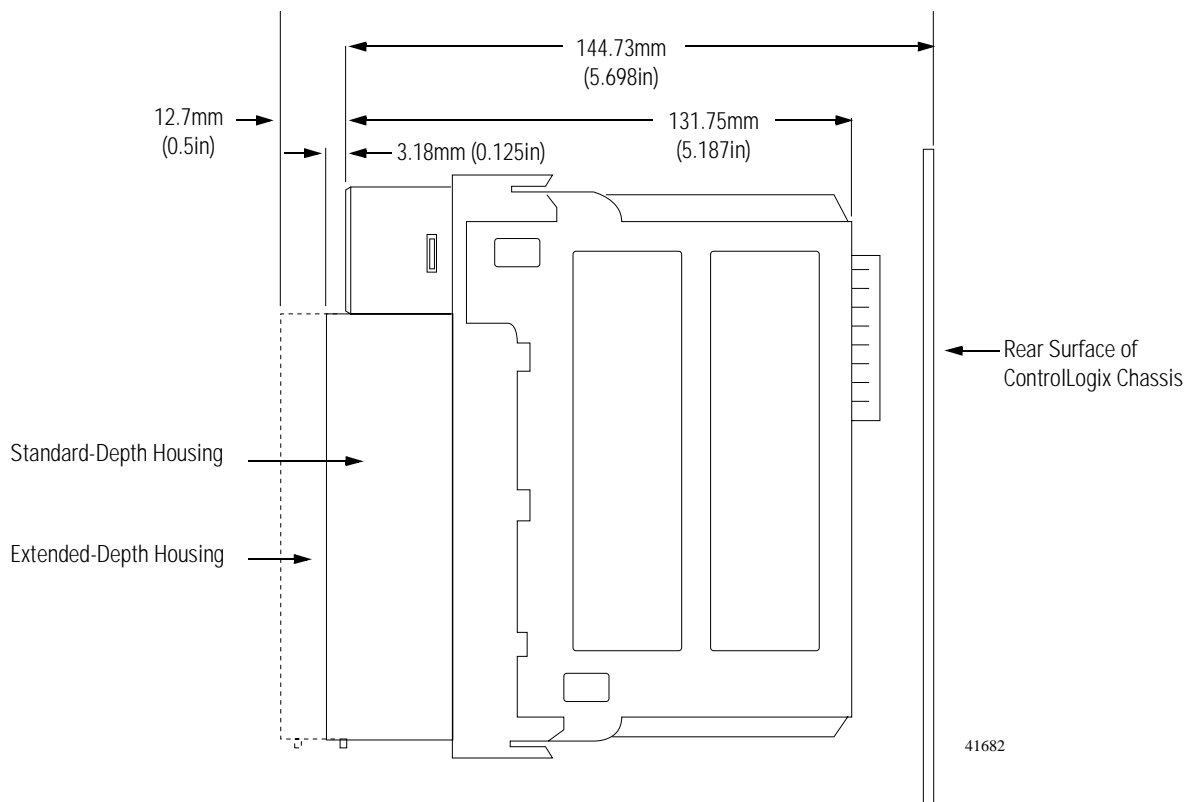

### IMPORTANT

The depth from front of the module to the back of the chassis is as follows:

- standard-depth housing = 147.91mm (5.823in)
- extended-depth housing = 157.43mm (6.198in)

## Installing the Removable Terminal Block

Install the RTB onto the module to connect wiring.

### ATTENTION



**Shock hazard exists.** If the RTB is installed onto the module while the field-side power is applied, the RTB will be electrically live. Do not touch the RTB's terminals. Failure to observe this caution may cause personal injury. The RTB is designed to support Removal and Insertion Under Power (RIUP). However, when you remove or insert an RTB with field-side power applied, **unintended machine motion or loss of process control can occur.** Exercise extreme caution when using this feature. It is recommended that field-side power be removed before installing the RTB onto the module.

Before installing the RTB, make certain:

- field-side wiring of the RTB has been completed.
- the RTB housing is snapped into place on the RTB.
- the RTB housing door is closed.
- the locking tab at the top of the module is unlocked.

1. Align the top, bottom and left side guides of the RTB with the guides on the module.

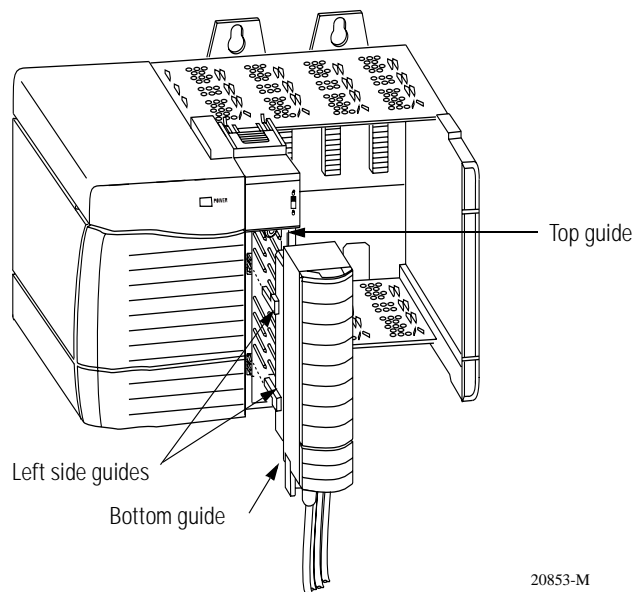

20853-M

2. Press quickly and evenly to seat the RTB on the module until the latches snap into place.

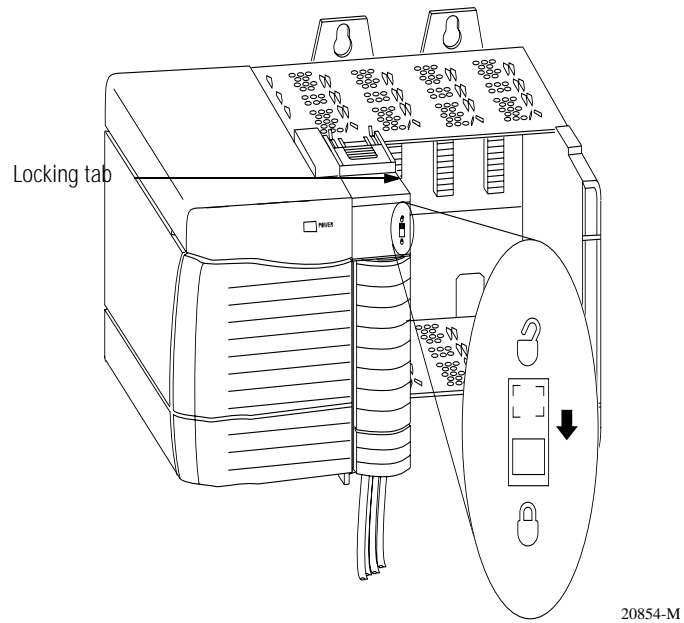

3. Slide the locking tab down to lock the RTB onto the module.

## Removing the Removable Terminal Block

If you need to remove the module from the chassis, you must first remove the RTB from the module.

### ATTENTION



**Shock hazard exists.** If the RTB is removed from the module while the field-side power is applied, the module will be electrically live. Do not touch the RTB's terminals. Failure to observe this caution may cause personal injury.

The RTB is designed to support Removal and Insertion Under Power (RIUP). However, when you remove or insert an RTB with field-side power applied, **unintended machine motion or loss of process control can occur.** Exercise extreme caution when using this feature. It is recommended that field-side power be removed before removing the module.

1. Unlock the locking tab at the top of the module.
2. Open the RTB door using the bottom tab.
3. Hold the spot marked PULL HERE and pull the RTB off the module.

### IMPORTANT

Do not wrap your fingers around the entire door. A shock hazard exists.

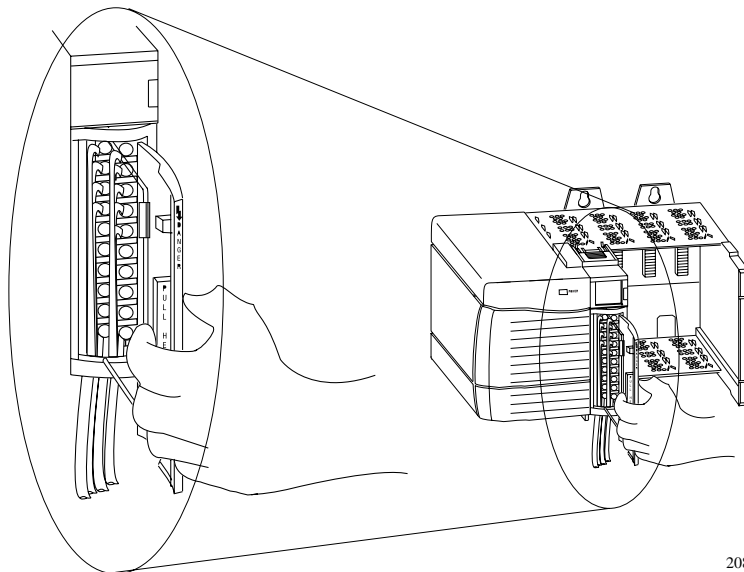

20855-M

## Removing the Module from the Chassis

1. Push in the top and bottom locking tabs.

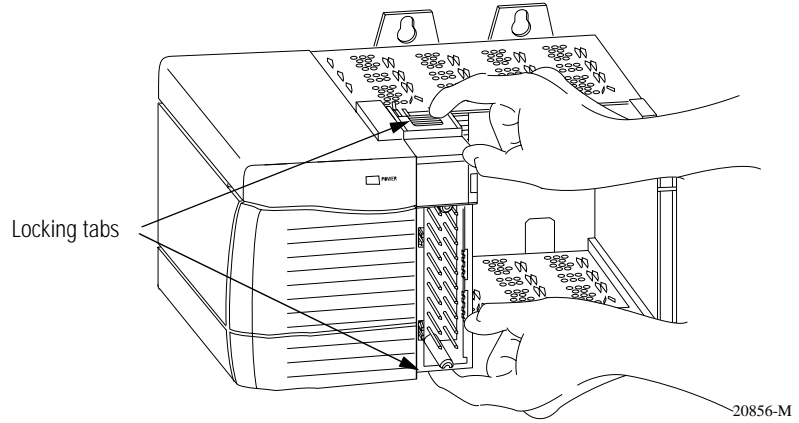

2. Pull module out of the chassis.

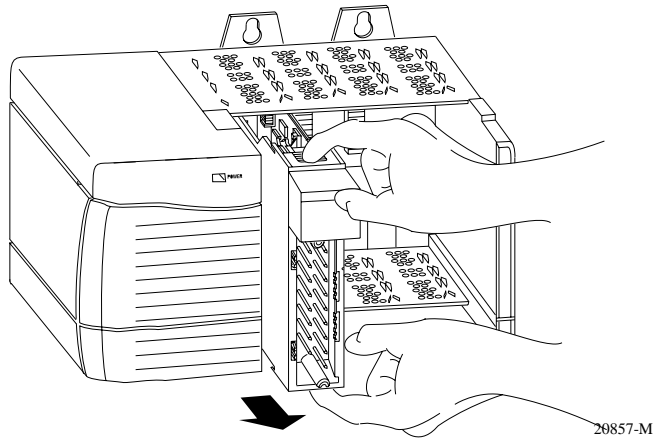

## Chapter Summary and What's Next

In this chapter you learned about:

- installing the module.
- keying the removable terminal block and the interface module.
- connecting wiring.
- assembling the removable terminal block and the housing.
- installing the removable terminal block or interface module onto the module.
- removing the removable terminal block from the module.
- removing the module from the chassis.

Move on to Chapter 6, Configuring Your ControlLogix Digital I/O Modules.

## Configuring Your ControlLogix Digital I/O Modules

**What This Chapter Contains** This chapter describes why you must configure your ControlLogix digital I/O modules and how to configure them for use in the ControlLogix system.

<b>For information about:</b>	<b>See page:</b>
Configuring Your I/O Module	6-2
Overview of the Configuration Process	6-2
Creating a New Module	6-4
Using the Default Configuration	6-10
Altering the Default Configuration	6-10
Configuring a Standard Input Module	6-12
Configuring a Standard Output Module	6-13
Configuring a Diagnostic Input Module	6-14
Configuring a Diagnostic Output Module	6-15
Editing Configuration	6-16
Reconfiguring Module Parameters in Remote Run Mode	6-17
Reconfiguring Module Parameters in Program Mode	6-18
Configuring I/O Modules in a Remote Chassis	6-19
Input Online Services	6-21
Output Online Services	6-22
Viewing and Changing Module Tags	6-23
Chapter Summary and What's Next	6-24

## Configuring Your I/O Module

You must configure your module upon installation. The module will not work until it has been configured.

---

**IMPORTANT**

This chapter focuses on configuring I/O modules in a local chassis. To configure I/O modules in a remote chassis, you must follow all the detailed procedures with two additional steps. An explanation of the additional steps is listed at the end of this chapter.

---

## RSLogix 5000 Configuration Software

Use RSLogix 5000 software to set configuration for your ControlLogix digital I/O module. You have the option of accepting default configuration for your module or writing point level configuration specific to your application.

Both options are explained in detail, including views of software screens, in this chapter.

## Overview of the Configuration Process

When you use the RSLogix 5000 software to configure a ControlLogix digital I/O module, you must perform the following steps:

1. Create a new module.
2. Accept the default configuration or change it to specific configuration for the module.
3. Edit configuration for a module when changes are needed.

The following diagram shows an overview of the configuration process.

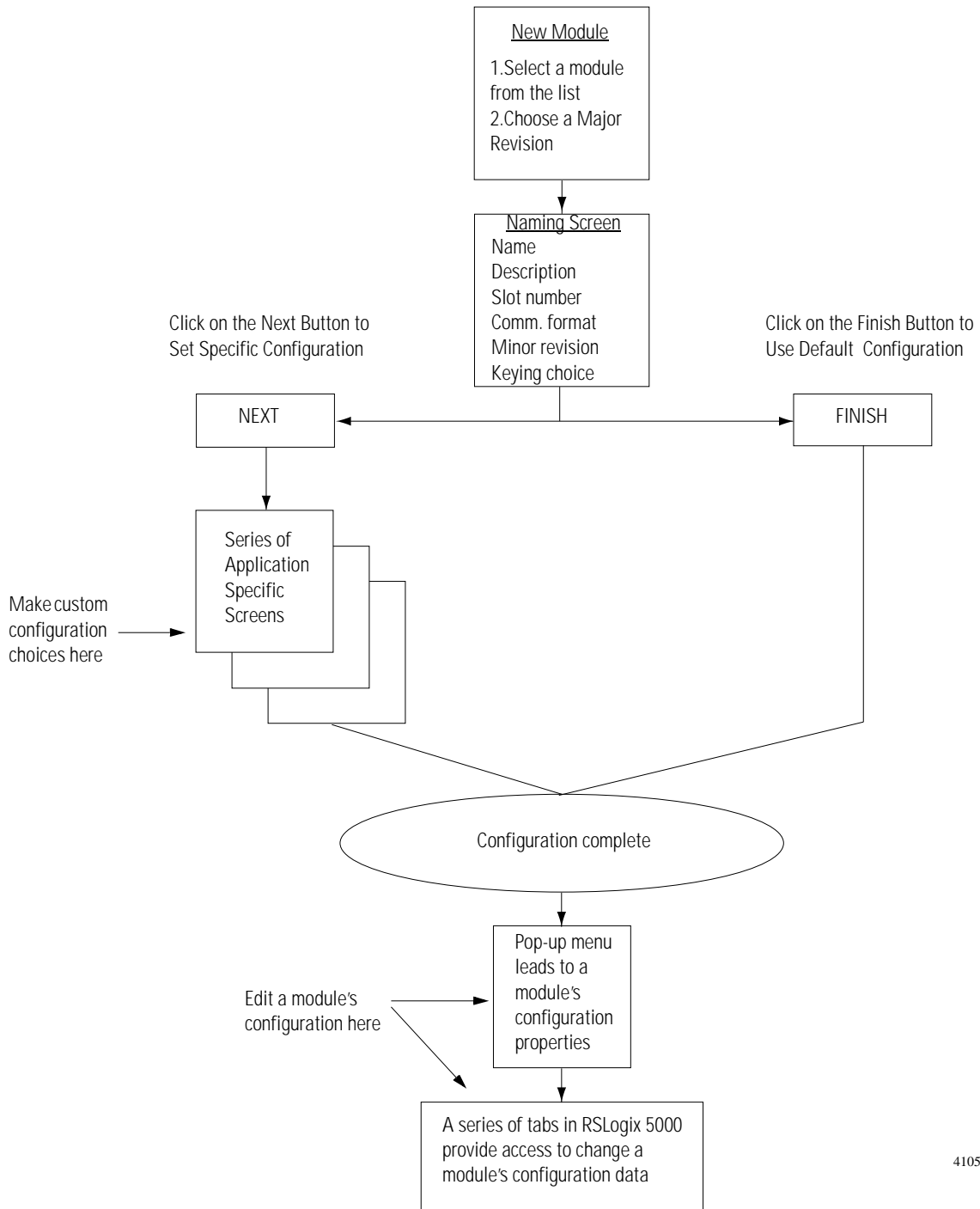

41058

## Creating a New Module

After you have started RSLogix 5000 and created a controller, you must create a new module. The wizard allows you to create a new module and write configuration. You can use default configuration or write specific configuration for your application.

**IMPORTANT**

You must be offline when you create a new module

If you are not offline, use this pull-down menu to go offline



When you are offline, you must select a new module.

1. Select I/O Configuration.
2. Click on the right mouse button to display the menu.
3. Select New Module

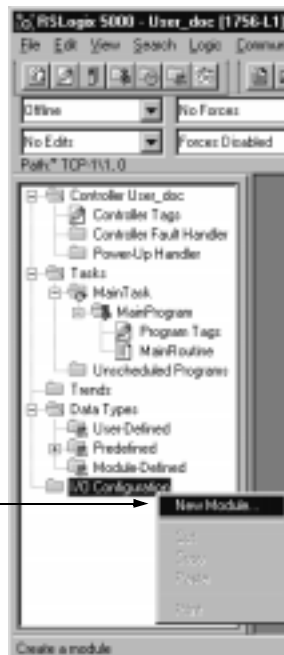

A screen appears with a list of possible new modules for your application.

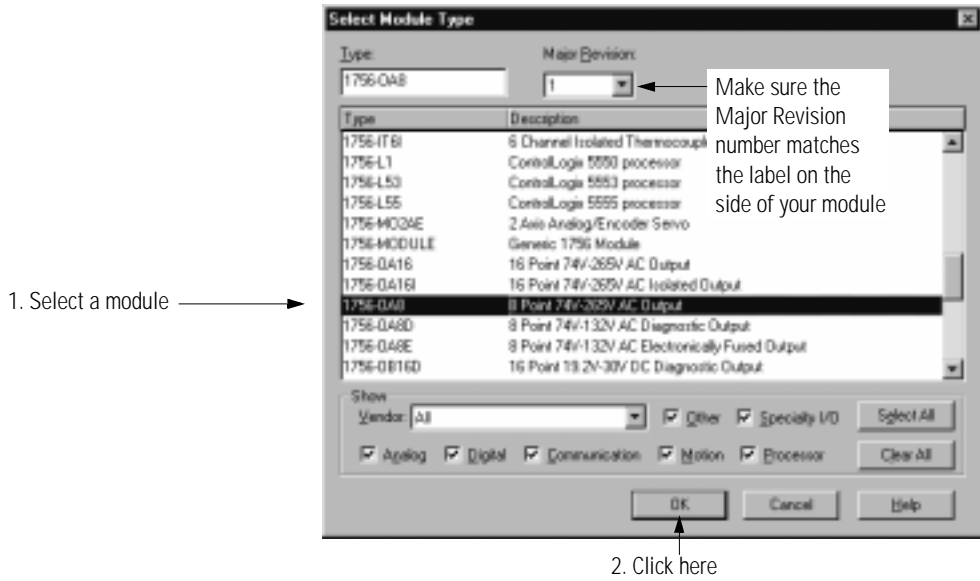

The new module creation wizard appears.

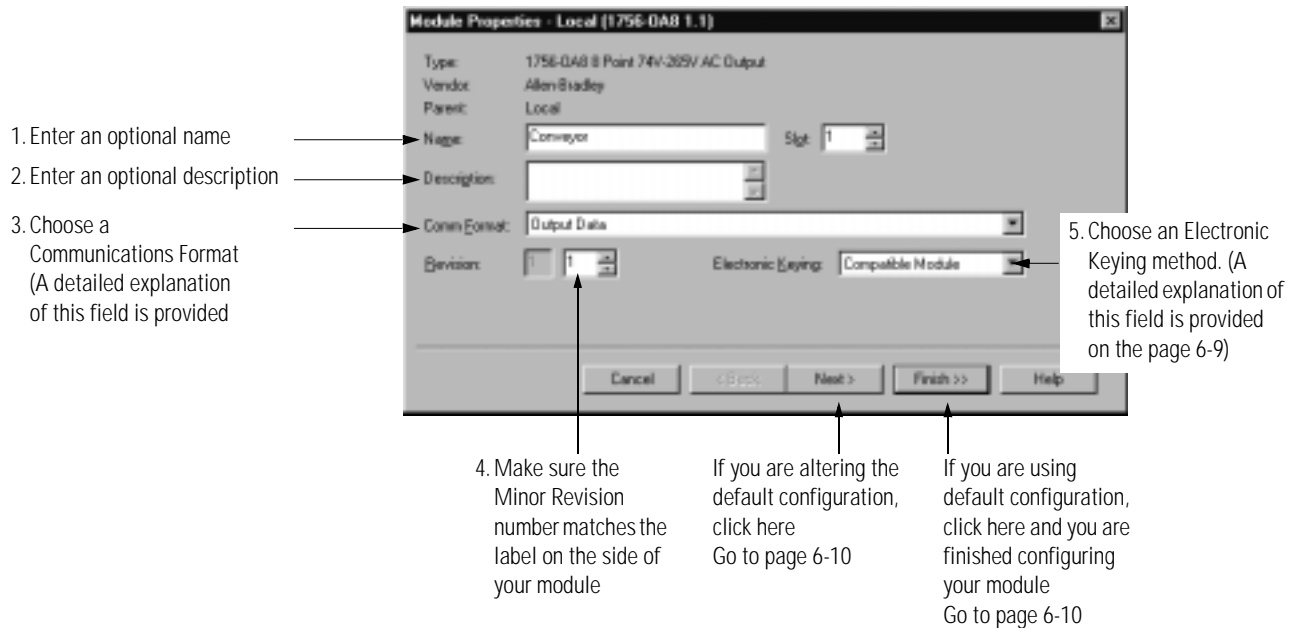

## Communications Format

The communications format determines what type of configuration options are made available, what type of data is transferred between the module and its owner controller, and what tags are generated when configuration is complete.

This feature also defines the connection between the controller writing the configuration and the module itself. The number and type of choices varies depending on which input module you are using and whether it is in a local or remote chassis.

### TIP



When you select a Listen-only Communications Format, only the General and Connection tabs appear when you view a module's properties in RSLogix 5000.

### *Input Module Formats*

The following are possible Communications Format choices for input modules:

- **input data** - module returns only general fault and input data
- **CST timestamped input data** - module returns input data with the value of the system clock (from its local chassis) when the input data changed
- **Full diagnostic input data** - module returns input data, the value of the system clock (from its local chassis) when the input data changed, and diagnostic data (diagnostic modules only)
- **Rack optimization** - the 1756-CNB module collects all digital input words in the remote chassis and sends them to the controller as a single rack image. This connection type limits the status and diagnostic information available

These additional Communications Format choices are used by controllers that want to listen to an input module but not own it. The choices have the same definition as those above:

- **Listen only - input data**
- **Listen only - CST timestamped input data**
- **Listen only - full diagnostic input data**
- **Listen only - rack optimization**

For example, the screen below shows the choices available when you are configuring a 1756-IA16I module in a local chassis.

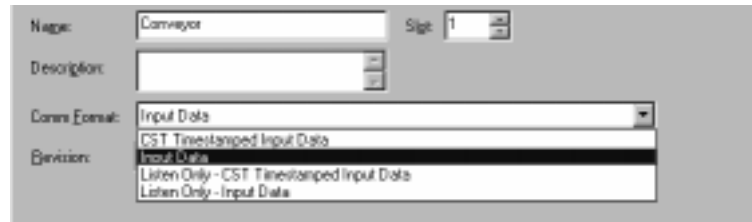

### IMPORTANT

Once the module is created, the communications format cannot be changed. The module must be deleted and recreated.

### *Output Module Formats*

The following are possible Communications Format choices for output modules:

As with input modules, the number and type of choices varies depending on which output module you are using and whether it is in a local or remote chassis.

The following are possible Communications Format choices for output modules:

- **output data** - owner controller sends the module only output data
- **CST timestamped fuse data - output data** - owner controller sends the module only output data. Module returns fuse blown status with the value of the system clock (from its local chassis) when the fuse was either blown or reset
- **Full diagnostic - output data** - owner controller sends the module only output data. Module returns diagnostic data and a timestamp of diagnostics
- **Scheduled output data** - owner controller sends the module output data and a CST timestamp value

- **CST timestamped fuse data - scheduled output data** - owner controller sends the module output data and a CST timestamp value. Module returns fuse blown status with the value of the system clock (from its local chassis) when the fuse was either blown or reset
- **Full diagnostics - scheduled output data** - owner controller sends the module output data and a CST timestamp value. Module returns diagnostic data and a timestamp of diagnostics
- **Rack optimization** - owner controller sends all digital output words to the remote chassis as a single rack image

These additional Communications Format choices are used by controllers that want to listen to an output module but not own it. The choices have the same definition as those above.

- **Listen only - output data**
- **Listen only - CST timestamped fuse data - output data**
- **Listen only - full diagnostics - output data**
- **Listen only - rack optimization**

For example, the screen below shows the choices available when you are configuring a 1756-OA8 module in a local chassis.

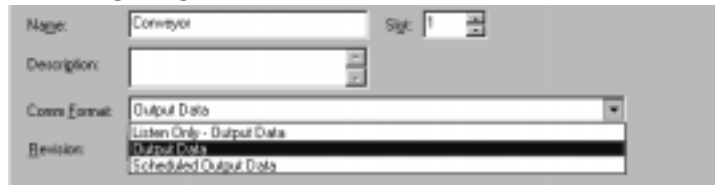

---

**IMPORTANT**

Once the module is created, the communications format cannot be changed. The module must be deleted and recreated.

---

The following table lists the Communications Formats available on each module:

**Table 6.A**  
**Communications Formats**

Module:	Available Communications Formats:
1756-IA16, -IA16I, IM16I, -IB16I, -IB16, -IB32, -IC16, -IH16I, -IN16, -IV16	Input data CST timestamped input data Rack optimization Listen only - input data Listen only - CST timestamped input data Listen only - rack optimization
1756-IA8D, -IB16D	Full diagnostics - input data Listen only - full diagnostics - input data
1756-OA16, -OA8E, -OB16E, -OB8EI, -OV16E	CST timestamped fuse data - output data CST timestamped fuse data - scheduled output data Listen only - CST timestamped fuse data - output data
1756-OA16I, -OA8, -OB16I, -OB32, -OB8, -OC8, -OH8I, -ON8, -OW16I, -OX8I	Output data Scheduled output data Rack optimization Listen only - output data Listen only - rack optimization
1756-OA8D, -OB16D	Full diagnostics - output data Full diagnostics - scheduled output data Listen only - full diagnostics - output data

## Electronic Keying

When you write configuration for a module you can choose how specific the keying must be when a module is inserted into a slot in the chassis.

For example, the screen below shows the choices available when you are configuring a 1756-OA8 module.



For a detailed explanation about electronic keying options, see page 4.

## Using the Default Configuration

If you use the default configuration and click on Finish, you are done.

## Altering the Default Configuration

If you want to alter or view the default configuration, click on Next. You will be taken through a series of wizard screens that enable you to alter or view the module.

Although each screen maintains importance during online monitoring, two of the screens that appear during this initial module configuration process are blank. They are shown here to maintain the graphical integrity of RSLogix 5000. To see these screens in use, see page 8-4.

After the naming page, this screen appears.

Adjust the Requested Packet Interval here  
 Inhibit the connection to the module here  
 If you want a Major Fault on the Controller to occur if there is connection failure with the I/O module, click here

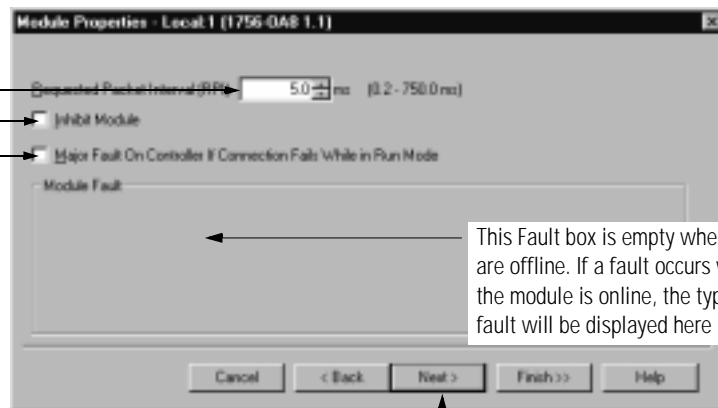

This Fault box is empty when you are offline. If a fault occurs while the module is online, the type of fault will be displayed here

Click here to move to the next page

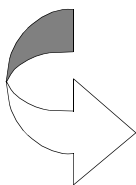

This screen is used during online monitoring but not initial configuration



Click here to move to the next page

The configuration page appears next. For example, this screen appears for the 1756-OA8 module. The choices available on the configuration screen will vary according to the module selected.

Set the state of the outputs in Program Mode

Communications Failure in Program Mode  
Choose a state for the outputs if communications fail in Program Mode

**IMPORTANT:** Outputs always go to Fault mode if communications fail in Run mode

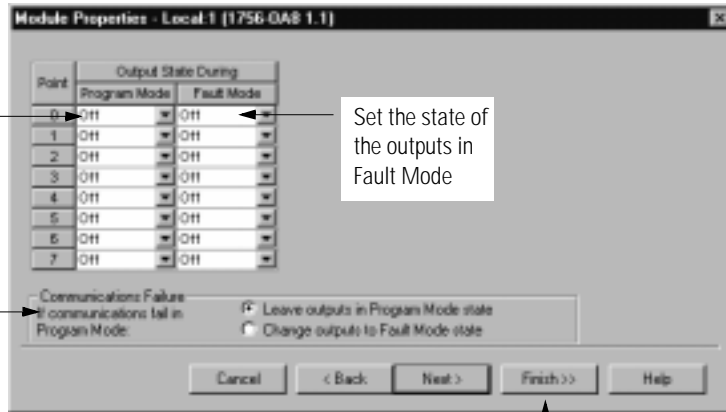

Set the state of the outputs in Fault Mode

Click here to accept the parameters you have configured for your module

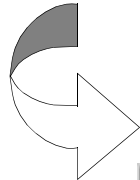

This screen appears last in the wizard series of screens. It is used during online monitoring but not initial configuration

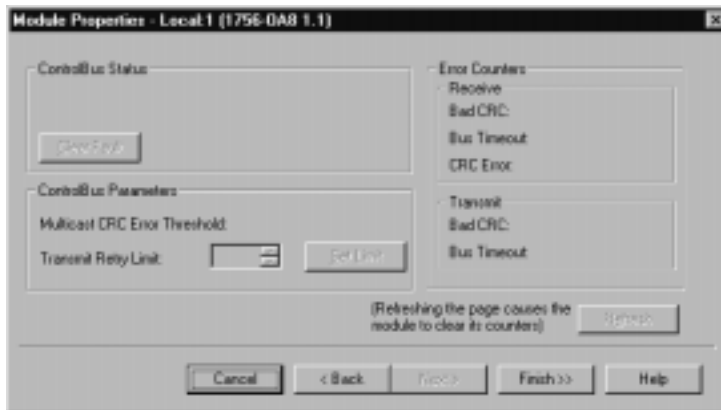

## Configuring a Standard Input Module

The following ControlLogix digital input modules are standard input modules:

- 1756-IA16
- 1756-IA16I
- 1756-IB16
- 1756-IB16I
- 1756-IB32
- 1756-IC16
- 1756-IH16I
- 1756-IM16I
- 1756-IN16
- 1756-IV16
- 1756-IV32

The configurable features for a standard input module are:

- Change of State
- Input Filter Times

Create a new module in RSLogix 5000 as described on page 6-4. Use the following page to configure your standard input module.

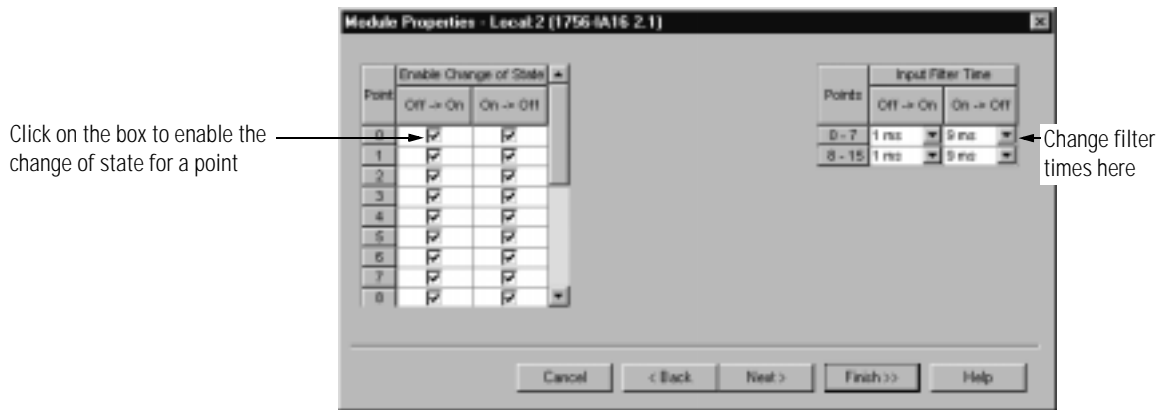

## Configuring a Standard Output Module

The following ControlLogix digital output modules are standard output modules:

- 1756-OA16
- 1756-OA16I
- 1756-OA8
- 1756-OA8E
- 1756-OB16E
- 1756-OB16I
- 1756-OB32
- 1756-OB8
- 1756-OB8EI
- 1756-OC8
- 1756-OH8I
- 1756-ON8
- 1756-OW16I
- 1756-OX8I

The configurable features for a standard output module are:

- Output State in Program Mode
- Output State in Fault Mode
- Transition from Program State to Fault State
- Field Power Loss Detection - 1756-OA8E only
- Diagnostic Latching - 1756-OA8E only

Create a new module in RSLogix 5000 as described on page 6-4. Use the following page to configure your standard output module.

Change the Program Mode value here

Change the Fault Mode value here

Enable Field Power Loss here

Choose the state of outputs after a Communications Failure here

Enable diagnostic latching here

Point	Output State During		Enable Diagnostics for		Enable Diag. Latching
	Program Mode	Fault Mode	Field Power Loss		
0	Off	Off	<input type="checkbox"/>	<input type="checkbox"/>	<input type="checkbox"/>
1	Off	Off	<input type="checkbox"/>	<input type="checkbox"/>	<input type="checkbox"/>
2	Off	Off	<input type="checkbox"/>	<input type="checkbox"/>	<input type="checkbox"/>
3	Off	Off	<input type="checkbox"/>	<input type="checkbox"/>	<input type="checkbox"/>
4	Off	Off	<input type="checkbox"/>	<input type="checkbox"/>	<input type="checkbox"/>
5	Off	Off	<input type="checkbox"/>	<input type="checkbox"/>	<input type="checkbox"/>
6	Off	Off	<input type="checkbox"/>	<input type="checkbox"/>	<input type="checkbox"/>
7	Off	Off	<input type="checkbox"/>	<input type="checkbox"/>	<input type="checkbox"/>

Communications Failure if communications fail in Program Mode:

Leave outputs in Program Mode state

Change outputs to Fault Mode state

Buttons: Cancel, < Back, Next >, Finish >>, Help

## Configuring a Diagnostic Input Module

The following ControlLogix digital input modules are diagnostic input modules:

- 1756-IA8D
- 1756-IB16D

The configurable features for a diagnostic input module are:

- Input Change of State
- Input Filter Times
- Open Wire Detection
- Field Power Loss Detection
- Diagnostic Latching
- Diagnostic Change of State

Create a new module in RSLogix 5000 as described on page 6-4. Use the following pages to configure your diagnostic input module.

Enable Change of State here

Enable Open Wire here

Enable Field Power Loss here

Enable Diagnostic Latching here

Enable Change of State for Diagnostic Transitions here

Change filter times here.

One diagnostic, Reset Latched Diagnostics, is not used when writing configuration but is typically accessed during online monitoring. For more information on how to reset Latched Diagnostics, see page 6-21.

## Configuring a Diagnostic Output Module

The following ControlLogix digital output modules are diagnostic output modules:

- 1756-OA8D
- 1756-OB16D

The configurable features for a diagnostic output module are:

- Output State in Program Mode
- Output State in Fault Mode
- Transition from Program State to Fault State
- Field Power Loss Detection - 1756-OA8D & 1756-OA8E only
- No Load Detection
- Diagnostic Latching
- Output Verify Detection

Create a new module in RSLogix 5000 as described on page 6-4. Use the following pages to configure your diagnostic output module.

Point	Output State During		Enable Diagnostics for			Enable Diag. Latching
	Program Mode	Fault Mode	Output Verify	No Load	Field Power Loss	
0	Off	Off	<input checked="" type="checkbox"/>	<input checked="" type="checkbox"/>	<input checked="" type="checkbox"/>	<input checked="" type="checkbox"/>
1	Off	Off	<input checked="" type="checkbox"/>	<input checked="" type="checkbox"/>	<input checked="" type="checkbox"/>	<input checked="" type="checkbox"/>
2	Off	Off	<input checked="" type="checkbox"/>	<input checked="" type="checkbox"/>	<input checked="" type="checkbox"/>	<input checked="" type="checkbox"/>
3	Off	Off	<input checked="" type="checkbox"/>	<input checked="" type="checkbox"/>	<input checked="" type="checkbox"/>	<input checked="" type="checkbox"/>
4	Off	Off	<input checked="" type="checkbox"/>	<input checked="" type="checkbox"/>	<input checked="" type="checkbox"/>	<input checked="" type="checkbox"/>
5	Off	Off	<input checked="" type="checkbox"/>	<input checked="" type="checkbox"/>	<input checked="" type="checkbox"/>	<input checked="" type="checkbox"/>
6	Off	Off	<input checked="" type="checkbox"/>	<input checked="" type="checkbox"/>	<input checked="" type="checkbox"/>	<input checked="" type="checkbox"/>
7	Off	Off	<input checked="" type="checkbox"/>	<input checked="" type="checkbox"/>	<input checked="" type="checkbox"/>	<input checked="" type="checkbox"/>

Communications Failure If communications fail in Program Mode:

Leave outputs in Program Mode state

Change outputs to Fault Mode state

Annotations:

- Set the Program Mode value here (points to Program Mode dropdown for Point 0)
- Set the Fault Mode value here (points to Fault Mode dropdown for Point 0)
- Enable Output Verify here (points to Output Verify checkbox for Point 0)
- Enable No Load here (points to No Load checkbox for Point 0)
- Choose the state of outputs after a communications failure here (points to radio buttons)
- Enable Field Power Loss here (points to Field Power Loss checkbox for Point 0)
- Enable Diagnostic Latching here (points to Enable Diag. Latching checkbox for Point 0)

## Editing Configuration

After you have set configuration for a module, you can review and change your choices. You can change configuration data and download it to the controller while online. This is called **dynamic reconfiguration**.

Your freedom to change some configurable features, though, depends on whether the controller is in Remote Run Mode or Program Mode.

**IMPORTANT**

Although you can change configuration while online, you must go offline to add or delete modules from the project.

The editing process begins on the main page of RSLogix 5000.

1. Select the module.
2. Click on the right mouse button to display the menu
3. Select Properties

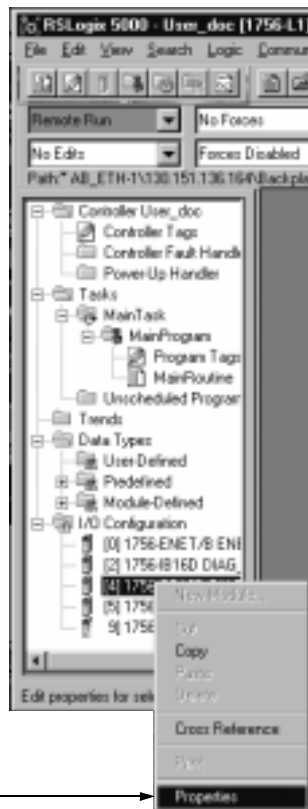

This screen appears.

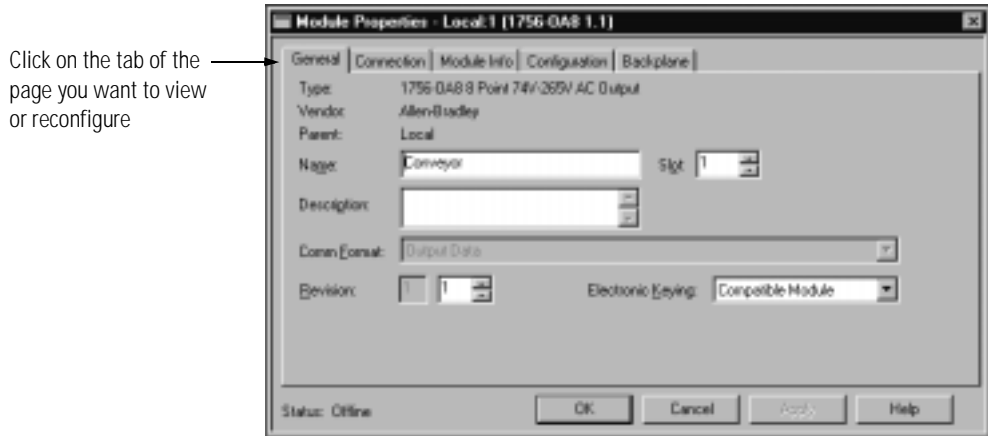

Click on the tab of the page you want to view or reconfigure

## Reconfiguring Module Parameters in Remote Run Mode

When the controller is in Remote Run Mode, you can change configurable features that are enabled by the software. If any feature is disabled (greyed out) in Remote Run Mode, change the controller to Program Mode and make the necessary changes.

For example, the following screen shows the configuration page for the 1756-OB16D module while it is in Remote Run Mode.

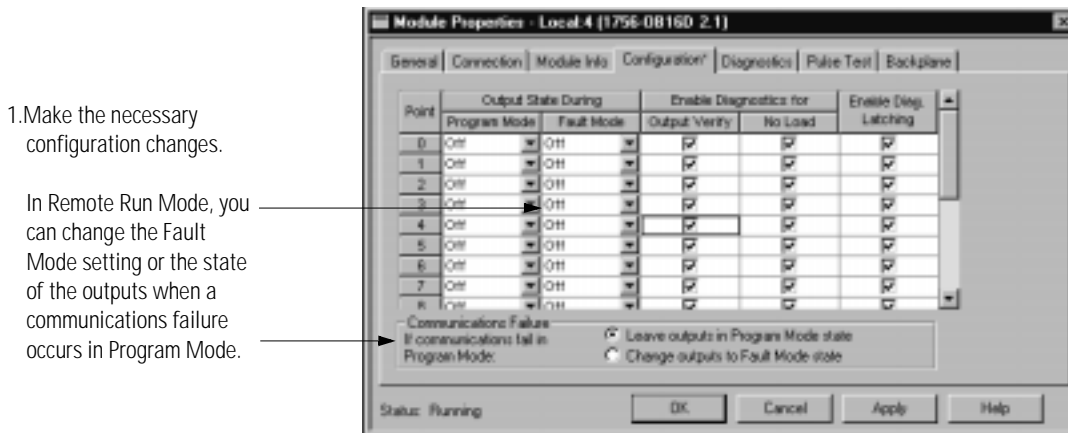

1. Make the necessary configuration changes.

In Remote Run Mode, you can change the Fault Mode setting or the state of the outputs when a communications failure occurs in Program Mode.

2. Click here to download the new data and close the screen

Click here to download the new data and keep the screen open

## Reconfiguring Module Parameters in Program Mode

Change the controller from Run Mode to Program Mode before changing configuration.

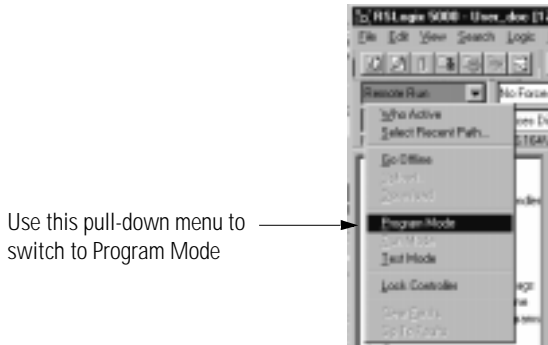

Make any necessary changes. For example, the RPI can only be changed in Program Mode and Remote Program Mode.

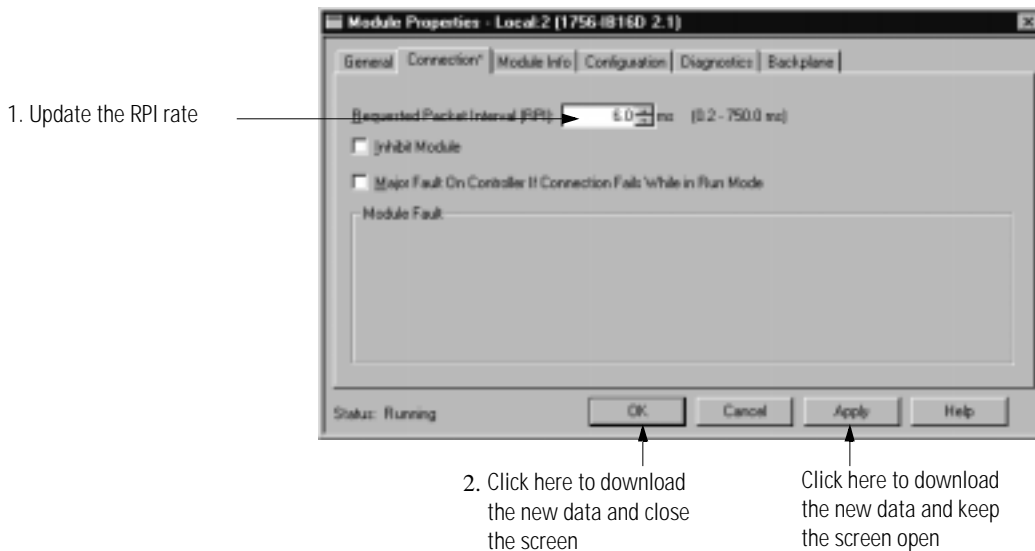

Before the RPI rate is updated online, RSLogix 5000 will verify your desired change.



The RPI has been changed and the new configuration data has been downloaded to the controller.

After making changes to your module's configuration in Program Mode, it is recommended that you change the module back to Run Mode.

## Configuring I/O Modules in a Remote Chassis

ControlLogix ControlNet Interface modules (1756-CNB or 1756-CNBR) are required to communicate with I/O modules in a remote chassis.

You must configure the communications module in the local chassis and the remote chassis before adding new I/O modules to the program.

1. Configure a communications module for the local chassis. This module handles communications between the controller chassis and the remote chassis.

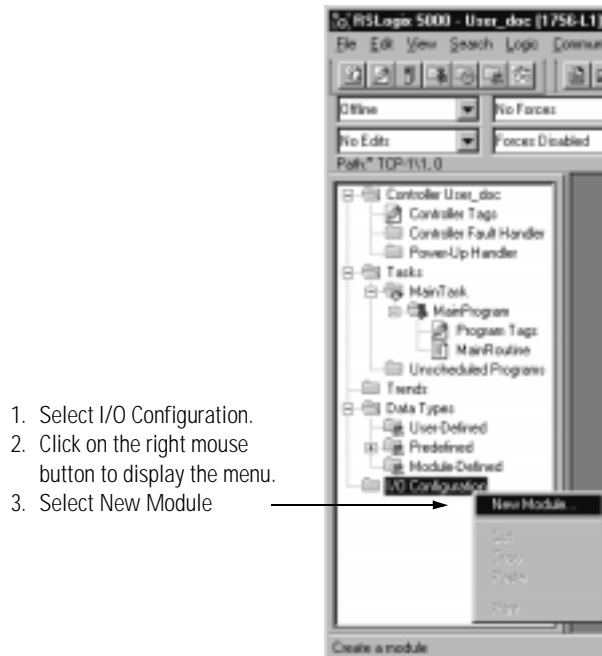

2. Choose a 1756-CNB or 1756-CNBR module and configure it.

For more information on the ControlLogix ControlNet Interface modules, see the ControlLogix ControlNet Interface Installation Instructions, publication 1756-5.32.

**3.** Configure a communications module for the remote chassis.

1. Select the local communications module
2. Click on the right mouse button and select New Module

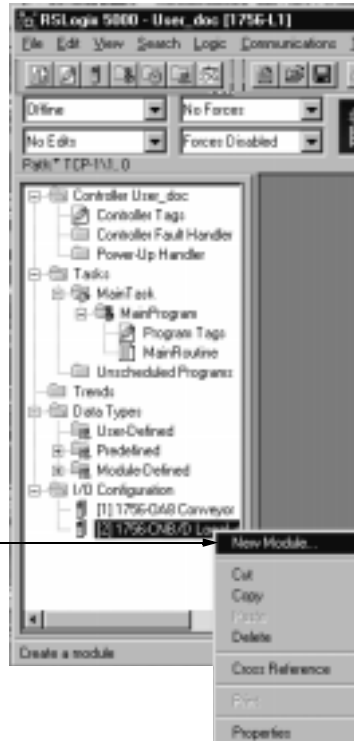

**4.** Choose a 1756-CNB or 1756-CNBR module and configure it.

**IMPORTANT:** Be aware of the two Communications Format choices available for 1756-CNB modules. For more information on the differences between Rack Optimization and Listen-Only Rack Optimization, see chapter 2.

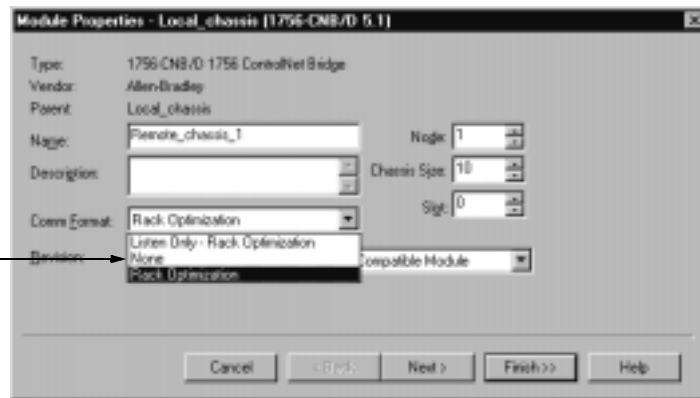

For more information on the ControlLogix ControlNet Interface modules, see the ControlLogix ControlNet Interface Installation Instructions, publication 1756-5.32.

Now you can configure the remote I/O modules by adding them to the remote communications module. Follow the same procedures as you do for configuring local I/O modules as detailed earlier in this chapter.

## Input Online Services

Diagnostic input modules have an additional pages of diagnostic services. The following diagnostic

- Reset Latched Diagnostics

is not used when writing configuration but are only accessed during online monitoring.

These screens are accessed through the module's properties.

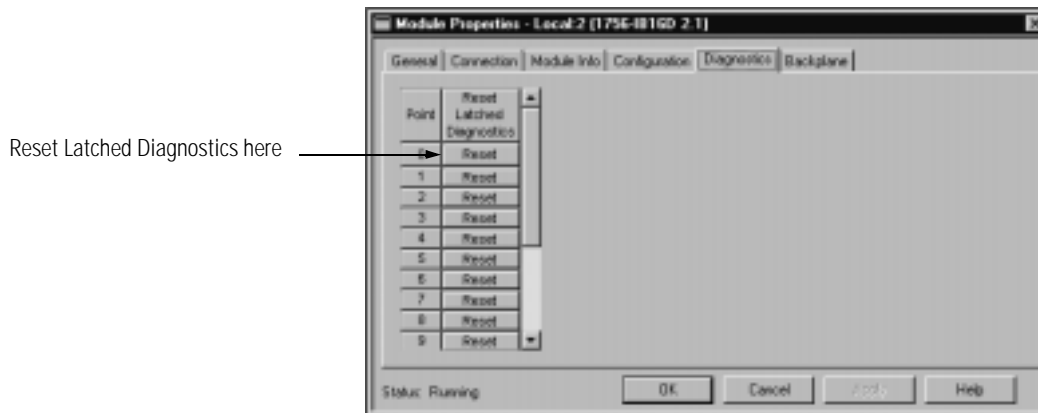

## Output Online Services

Diagnostic output modules have additional pages of diagnostic services. The following three diagnostics

- Electronic Fuse reset
- Reset Latched Diagnostics
- Pulse Test

are not used when writing configuration but are only accessed during online monitoring.

These screens are accessed through the module's properties.

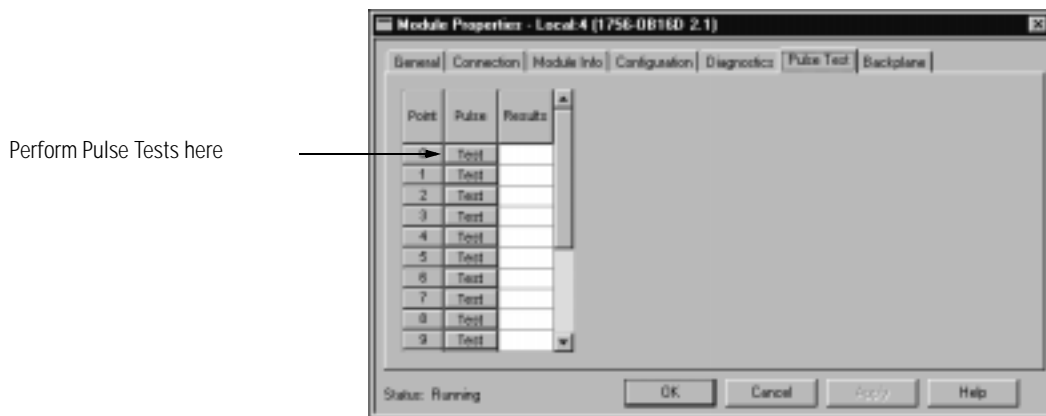
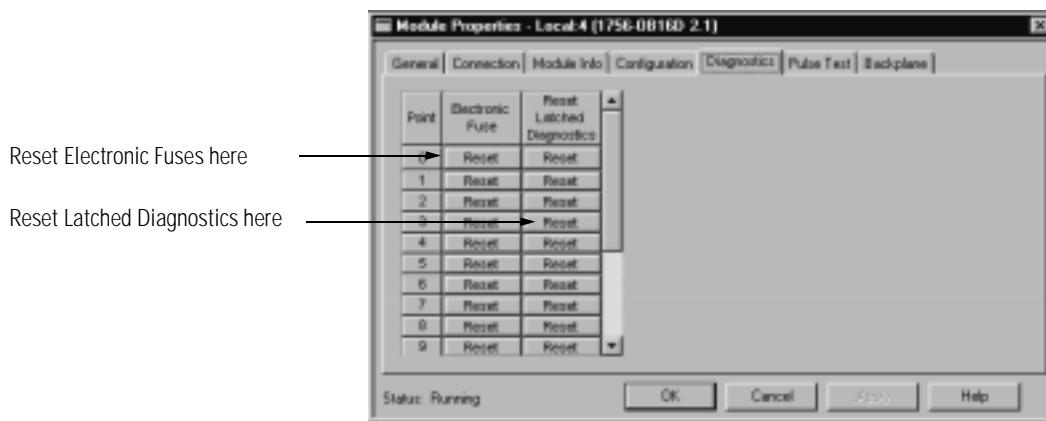

## Viewing and Changing Module Tags

When you create a module, a set of tags are created by the ControlLogix system that can be viewed in the Tag Editor of RSLogix 5000. Each configurable feature on your module has a distinct tag that can be used in the processor's ladder logic.

You can access a module's tags through RSLogix 5000 as shown below.

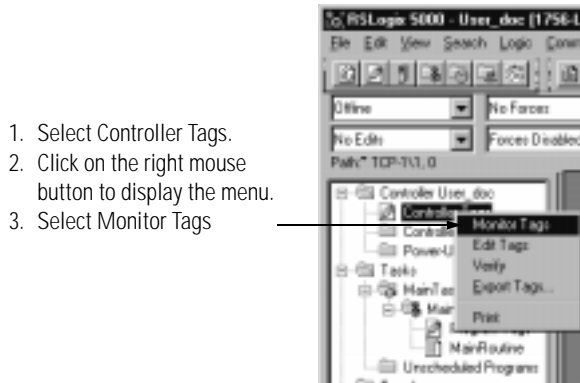

You can view the tags from here.



Because the process of viewing and changing a module's configuration tags is broader in scope than can be addressed in this chapter, you must turn to Appendix A for more information and sample tag collections.

## Chapter Summary and What's Next

In this chapter you learned about:

- configuring ControlLogix digital I/O modules
- configuration tags
- editing module configuration

Move on to Chapter 7, Module-Specific Information.

## Module-Specific Information

**What This Chapter Contains** This chapter provides module specific information for all ControlLogix digital modules. The information is separated by module and includes a list of:

- configurable functions
- wiring diagrams
- LED indicators
- simplified schematics
- surge currents (when applicable)

The following table lists where module-specific information can be found:

ControlLogix input Modules	
For module:	Refer to:
1756-IA16	7-2
1756-IA16I	7-4
1756-IA8D	7-6
1756-IB16	7-8
1756-IB16D	7-10
1756-IB16I	7-12
1756-IB32	7-14
1756-IC16	7-16
1756-IH16I	7-18
1756-IM16I	7-20
1756-IN16	7-22
1756-IV16	7-24
1756-IV32	7-26

ControlLogix output Modules	
For module:	Refer to:
1756-OA16	7-28
1756-OA16I	7-30
1756-OA8	7-32
1756-OA8D	7-34
1756-OA8E	7-36
1756-OB16D	7-38
1756-OB16E	7-40
1756-OB16I	7-42
1756-OB32	7-44
1756-OB8	7-46
1756-OB8EI	7-48
1756-OC8	7-50
1756-OH8I	7-52
1756-ON8	7-54
1756-OV16E	7-56
1756-OW16I	7-58
1756-OX8I	7-60

# 1756-IA16

## Configurable features

The following table lists the configurable features this module supports, the default value and the page of the feature's description:

Feature	Default value	Page of description
Change of State (COS)	OFF-ON: Enabled ON-OFF: Enabled	2-10
Software Configurable Filter Times	OFF-ON: 1ms ON-OFF: 9ms	3-11
Communications Format	Input data	6-6

## Wiring example

Use the following example to wire your module.

- NOTES:
1. All terminals with the same name are connected together on the module. For example, L2 can be connected to any terminal marked L2-0.
  2. Do not physically connect more than two wires to a single RTB terminal. When you daisy chain from a group to another RTB, always connect the daisy chain as shown.
  3. This wiring example shows a single voltage source.
  4. If separate power sources are used, do not exceed the specified isolation voltage.

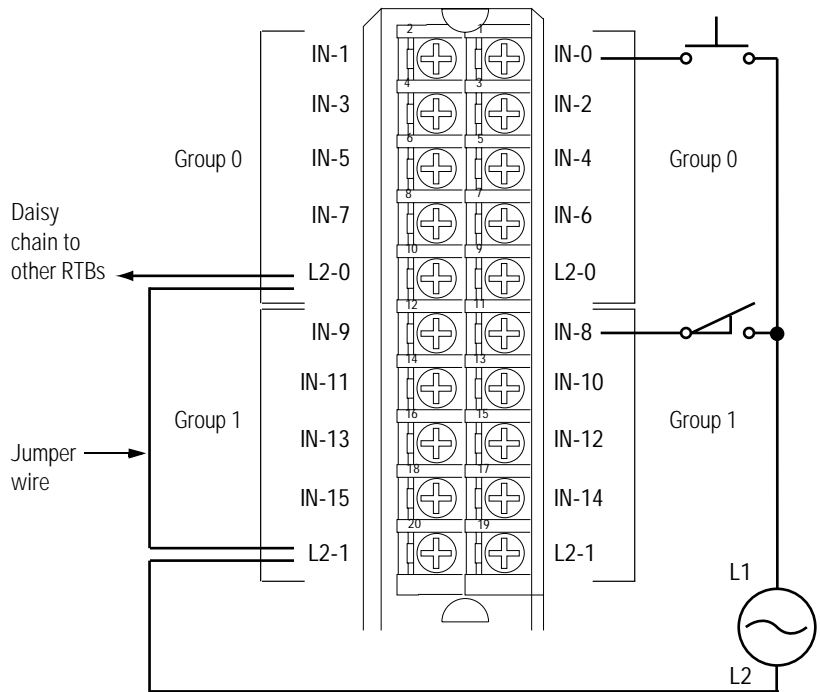

40176-M

Simplified schematic

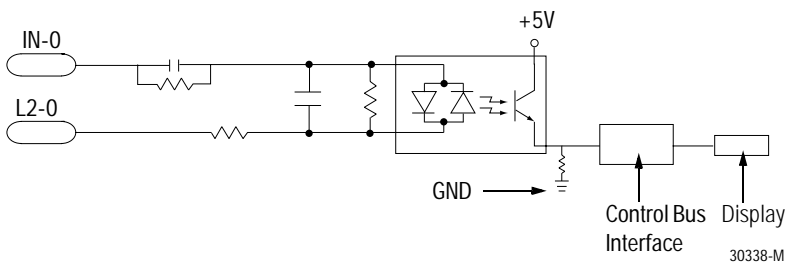



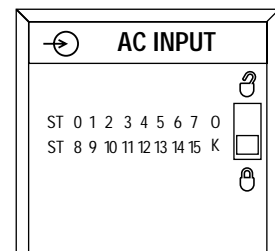

LED indicator



20945

## 1756-IA16 Specifications

Number of Inputs	16 (8 points/common)
Module Location	1756 ControlLogix Chassis
Backplane Current	105mA @ 5.1V dc & 2mA @ 24V dc (Total backplane power 0.58W)
Maximum Power Dissipation (Module)	5.8W @ 60°C
Thermal Dissipation	18.41 BTU/hr
On-State Voltage Range	74-132V ac, 47-63Hz
Nominal Input Voltage	120V ac
On-State Current	5mA @ 74V ac minimum 13mA @ 132V ac maximum
Maximum Off-State Voltage	20V
Maximum Off-State Current	2.5mA
Maximum Input Impedance @ 132V ac	10.15k $\Omega$ @ 60Hz
Input Delay Time Off to on Hardware delay On to off Hardware delay	Programmable filter: 1ms & 2ms 10ms maximum plus filter time Programmable filter: 9ms & 18ms 8ms maximum plus filter time
Diagnostic Functions Change of State Timestamp of Inputs	Software configurable +/- 200 $\mu$ s
Maximum Inrush Current	250mA
Change of State on Inputs	Software configurable (Within 200 $\mu$ s)
Cyclic Update Time	User selectable (100 $\mu$ s minimum/750ms maximum)
Isolation Voltage Group to group User to system	100% tested at 2546V dc for 1s (250V ac max. continuous voltage) 100% tested at 2546V dc for 1s (250V ac max. continuous voltage)
Module Keying (Backplane)	Software configurable
RTB Screw Torque (NEMA)	7-9 inch-pounds (0.8-1Nm)
RTB Keying	User defined mechanical keying
RTB and Housing	20 Position RTB (1756-TBNH or TBSH) <sup>1</sup>
Environmental Conditions Operating Temperature Storage Temperature Relative Humidity	0 to 60°C (32 to 140°F) -40 to 85°C (-40 to 185°F) 5 to 95% noncondensing
Conductors Wire Size Category	22-14 gauge (2mm <sup>2</sup> ) stranded <sup>1</sup> 3/64 inch (1.2mm) insulation maximum <sup>1,2,3</sup>
Screwdriver Blade Width for RTB	5/16 inch (8mm) maximum
Agency Certification (when product is marked)	 Listed Industrial Control Equipment  Certified Process Control Equipment Certified Class I, Division 2, Group A, B, C, D  Approved Class I, Division 2, Group A, B, C, D  Marked for all applicable directives  Marked for all applicable acts N223

<sup>1</sup> Maximum wire size will require extended housing - 1756-TBE.

<sup>2</sup> Use this conductor category information for planning conductor routing as described in the system level installation manual.

<sup>3</sup> Refer to publication 1770-4.1 "Industrial Automation Wiring and Grounding Guidelines".

# 1756-IA16I

## Configurable features

The following table lists the configurable features this module supports, the default value and the page of the feature's description:

Feature	Default value	Page of description
Change of State (COS)	OFF-ON: Enabled ON-OFF: Enabled	2-10
Software Configurable Filter Times	OFF-ON: 1ms ON-OFF: 9ms	3-11
Communications Format	Input data	6-6

## Wiring example

Use the following example to wire your module.

- NOTES:
1. All terminals with the same name are connected together on the module. For example, L2 can be connected to any terminal marked L2-15.
  2. Do not physically connect more than two wires to a single RTB terminal. When you use the second L2-15 terminal to daisy chain to other RTBs, always connect the daisy chain to the terminal directly connected to the supply wire as shown.
  3. The **jumper bar** part number is 97739201. Contact your local Rockwell Automation sales representative to order additional jumper bars, if necessary.
  4. If separate power sources are used, do not exceed the specified isolation voltage.

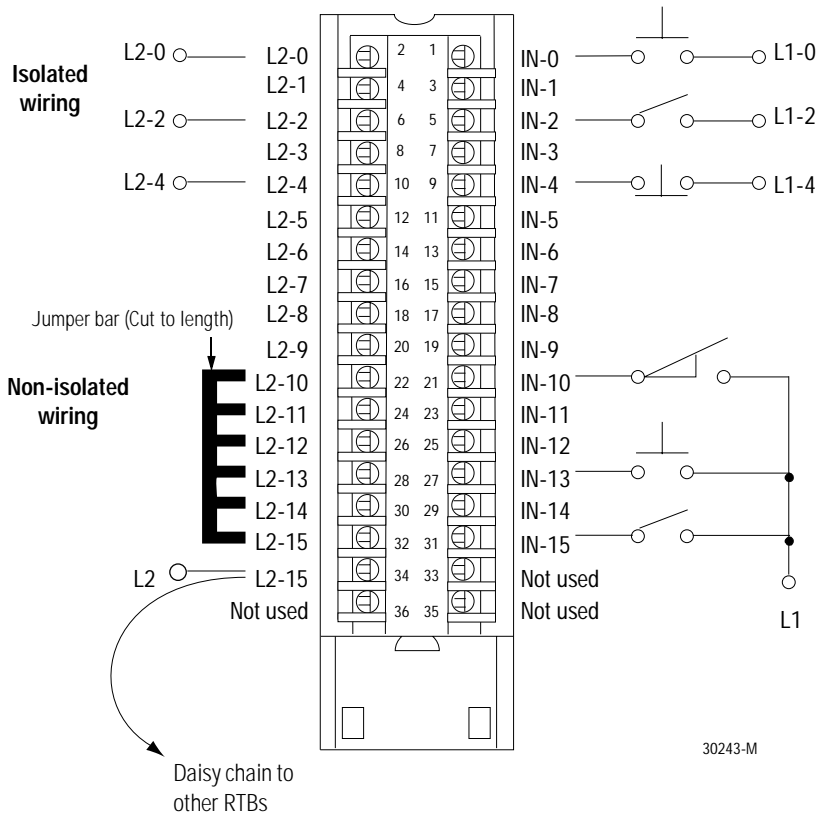

Simplified schematic

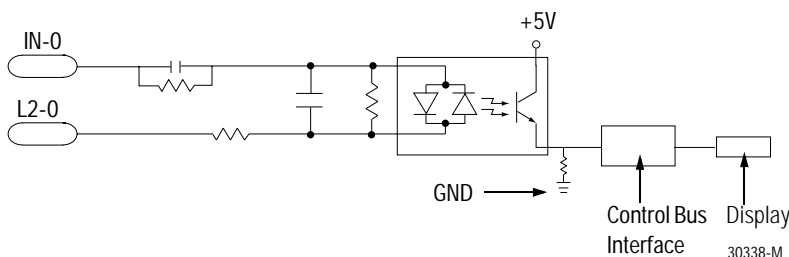

LED indicator

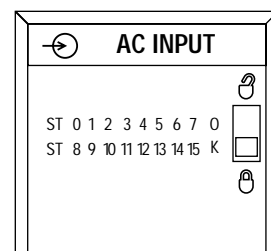

20945



# 1756-IA8D

## Configurable features

The following table lists the configurable features this module supports, the default value and the page of the feature's description:

Feature	Default value	Page of description
Change of State (COS)	OFF-ON: Enabled ON-OFF: Enabled	2-10
Software Configurable Filter Times	OFF-ON: 1ms ON-OFF: 9ms	3-11
Diagnostic Latch of Information	Enabled	4-11
Open Wire Detection	Enabled	4-15
Field Power Loss Detection	Enabled	4-16
Diagnostic Change of State for Output Modules	Enabled	4-25
Communications Format	Full diagnostics - input data	6-6

## Wiring example

Use the following example to wire your module.

- NOTES: 1. All terminals with the same name are connected together on the module. For example, L2 can be connected to any terminal marked L2-0.
- This wiring example shows a single voltage source.
  - Do not physically connect more than two wires to a single RTB terminal. When you daisy chain from a group to other RTBs, always connect the daisy chain as shown.
  - Resistors are not necessary if Wire Off diagnostic is not used.
  - If separate power sources are used, do not exceed the specified isolation voltage.

**To Determine Leakage Resistor**  
 (P/S = Field side power supply)  
 $R_{LEAK} \text{ Maximum} = (P/S \text{ Voltage} - 19V \text{ ac}) / 1.5 \text{ mA}$   
 $R_{LEAK} \text{ Minimum} = (P/S \text{ Voltage} - 20V \text{ ac}) / 2.5 \text{ mA}$

Recommended Values

P/S Voltage	$R_{LEAK}$ , 1/2W, 5%
100V ac +/- 10%	43kΩ
110V ac +/- 10%	47kΩ
115V ac +/- 10%	47kΩ
120V ac +/- 10%	51kΩ

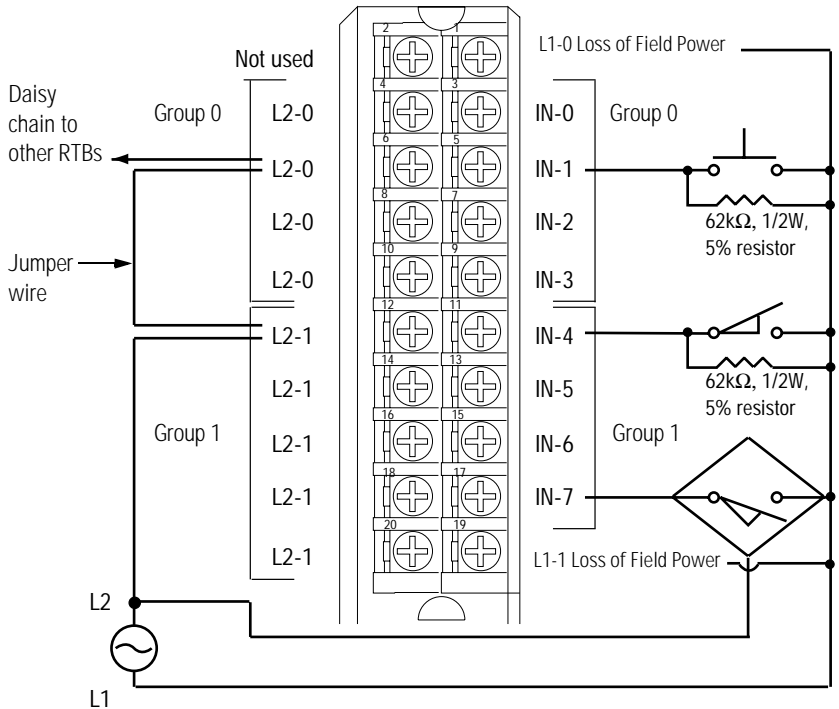

40202

### Simplified schematic

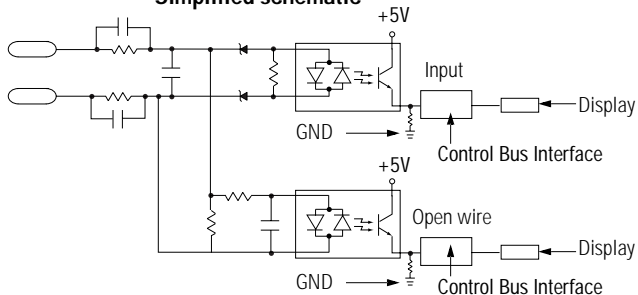



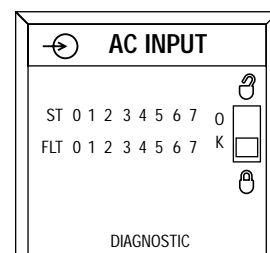

30340-M

### LED indicator



20927-M

## 1756-IA8D Specifications

Number of Inputs	8 (4 points/common)
Module Location	1756 ControlLogix Chassis
Backplane Current	100mA @ 5.1V dc & 3mA @ 24V dc (Total backplane power 0.58W)
Maximum Power Dissipation (Module)	4.5W @ 60°C
Thermal Dissipation	15.35 BTU/hr
On-State Voltage Range	79-132V ac, 47-63Hz
Nominal Input Voltage	120V ac
On-State Current	74V @ 5mA ac, 47-63Hz minimum 16mA @ 132V ac, 47-63Hz maximum
Maximum Off-State Voltage	20V
Maximum Off-State Current	2.5mA
Maximum Input Impedance @ 132V ac	8.25kΩ @ 60Hz
Input Delay Time OFF to ON Hardware Delay ON to OFF Hardware Delay	Programmable filter: 1ms & 2ms 10ms maximum plus filter time Programmable filter: 9ms & 18ms 8ms maximum plus filter time
Diagnostic Functions Open Wire Loss of Power Time Stamp of Diagnostics Change of State Time stamp of Inputs	Off state leakage current 1.5mA minimum Transition range 46 to 85V ac +/- 1ms Software configurable +/- 200μs
Maximum Inrush Current	250mA
Cyclic Update Time	User Selectable (200μs minimum/750ms maximum)
Isolation Voltage Group to group User to system	100% tested at 2546V dc for 1s (250V ac max. continuous voltage) 100% tested at 2546V dc for 1s (250V ac max. continuous voltage)
RTB Screw Torque (NEMA)	7-9 inch-pounds (0.8-1Nm)
Module Keying (Backplane)	Software configurable
RTB Keying	User defined mechanical keying
Field Wiring Arm and Housing	20 Position RTB (1756-TBNH or TBSH) <sup>1</sup>
Environmental Conditions Operating Temperature Storage Temperature Relative Humidity	0 to 60°C (32 to 140°F) -40 to 85°C (-40 to 185°F) 5 to 95% noncondensing
Conductors Wire Size Category	22-14 gauge (2mm <sup>2</sup> ) stranded <sup>1</sup> 3/64 inch (1.2mm) insulation maximum <sup>1,2,3</sup>
Screwdriver Width for RTB	5/16 inch (8mm) maximum
Agency Certification (when product or packaging is marked)	 Listed Industrial Control Equipment  Certified Process Control Equipment Certified Class I, Division 2, Group A, B, C, D  Approved Class I, Division 2, Group A, B, C, D  Marked for all applicable directives  Marked for all applicable acts N223

<sup>1</sup> Maximum wire size will require extended housing - 1756-TBE.

<sup>2</sup> Use this conductor category information for planning conductor routing as described in the system level installation manual.

<sup>3</sup> Refer to publication 1770-4.1 "Industrial Automation Wiring and Grounding Guidelines".

# 1756-IB16

## Configurable features

The following table lists the configurable features this module supports, the default value and the page of the feature's description:

Feature	Default value	Page of description
Change of State (COS)	OFF-ON: Enabled ON-OFF: Enabled	2-10
Software Configurable Filter Times	OFF-ON: 1ms ON-OFF: 1ms	3-11
Communications Format	Input data	6-6

## Wiring example

Use the following example to wire your module.

- NOTES:
1. All terminals with the same name are connected together on the module. For example, DC COM can be connected to either terminal marked GND-0.
  2. Do not physically connect more than two wires to a single RTB terminal. When you daisy chain from a group to another RTB, always connect the daisy chain as shown.
  3. This wiring example shows a single voltage source.
  4. If separate power sources are used, do not exceed the specified isolation voltage.

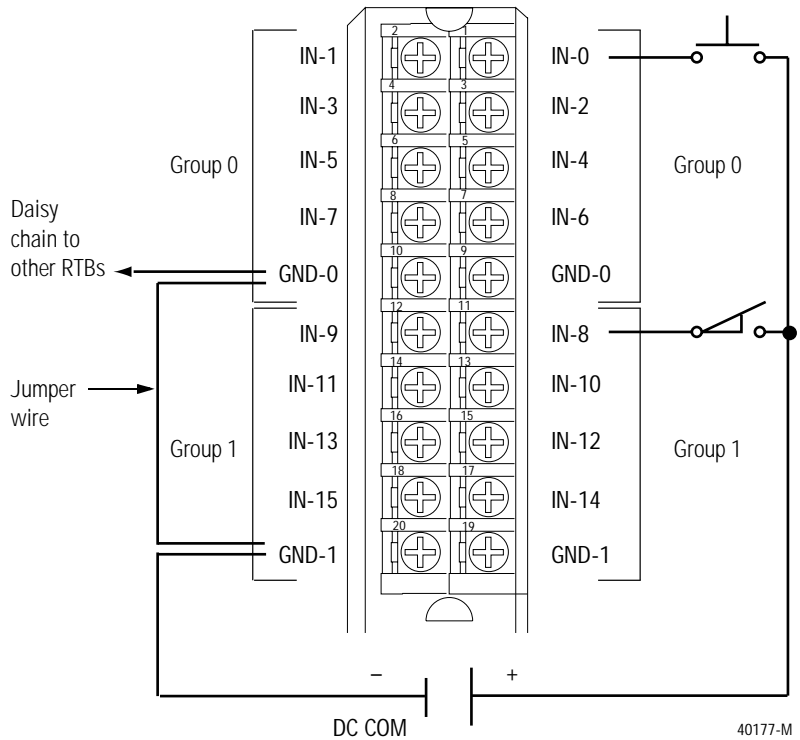

Simplified schematic

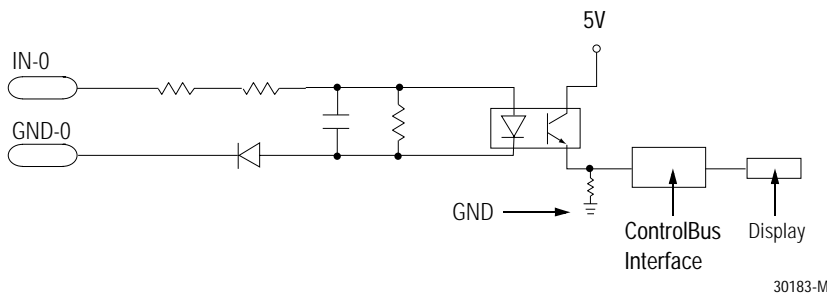

LED indicator

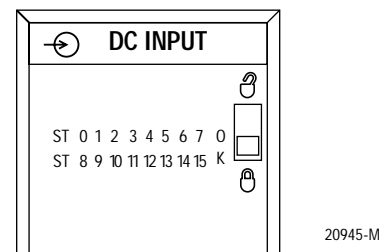



# 1756-IB16D

## Configurable features

The following table lists the configurable features this module supports, the default value and the page of the feature's description:

Feature	Default value	Page of description
Change of State (COS)	OFF-ON: Enabled ON-OFF: Enabled	2-10
Software Configurable Filter Times	OFF-ON: 1ms ON-OFF: 9ms	3-11
Diagnostic Latch of Information	Enabled	4-11
Open Wire Detection	Enabled	4-15
Diagnostic Change of State for Output Modules	Enabled	4-25
Communications Format	Full diagnostics - input data	6-6

## Wiring example

Use the following example to wire your module.

- NOTES:
1. All terminals with the same name are connected together on the module. For example, DC COM can be connected to any terminal marked GND-0.
  2. Do not physically connect more than two wires to a single RTB terminal. When you daisy chain from a group to other RTBs, away connect the daisy chain as shown.
  3. This wiring example shows a single voltage source.
  4. Resistors are not necessary if Wire Off diagnostic is not used.
  5. If separate power sources are used, do not exceed the specified isolation voltage.

**To Determine Leakage Resistor**

(P/S = Field side power supply)

$$R_{LEAK,Maximum} = (P/S \text{ Voltage} - 4.6V \text{ dc}) / 1.21mA$$

$$R_{LEAK,Minimum} = (P/S \text{ Voltage} - 5V \text{ dc}) / 1.5mA$$

**Recommended Values**

P/S Voltage	R <sub>LEAK</sub> , 1/4W, 2%
12V dc +/-5%	5.23kΩ
24V dc +/-5%	14.3kΩ

Daisy chain to other RTBs

Jumper wires

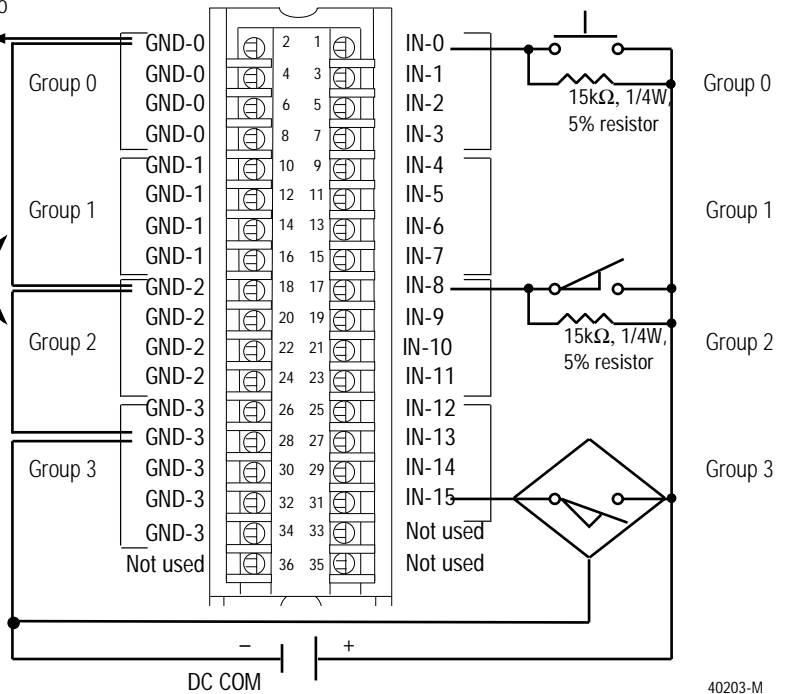

40203-M

**Simplified schematic**

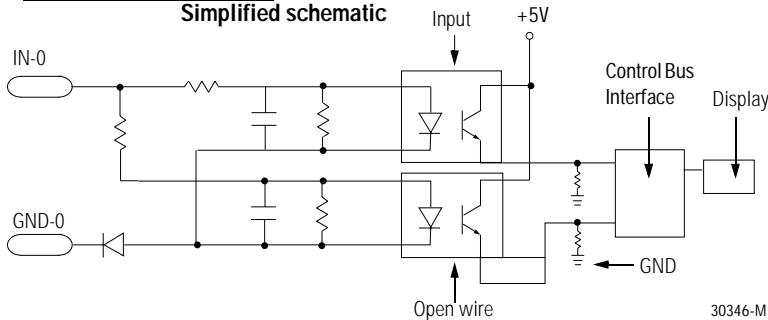



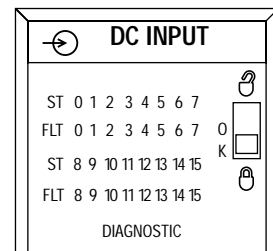

30346-M

**LED indicator**



40203-M

## 1756-IB16D Specifications

Number of Inputs	16 (4 points/common)
Module Location	1756 ControlLogix Chassis
Backplane Current	150mA @ 5.1V dc & 3mA @ 24V dc (Total backplane power 0.84W)
Max. Power Dissipation (Module)	5.8W @ 60°C
Thermal Dissipation	19.78 BTU/hr
On-State Voltage Range	10-30V dc
Nominal Input Voltage	24V dc
On-State Current	2mA @ 10V dc minimum 13mA @ 30V dc maximum
Maximum Off-State Voltage	5V dc
Minimum Off-State Current	1.5mA per point
Maximum Input Impedance @ 30V dc	2.31k $\Omega$
Input Delay Time OFF to ON Hardware ON to OFF Hardware delay	Programmable filter: 0ms, 1ms & 2ms 1ms maximum plus filter time Programmable filter: 0ms, 1ms, 9ms & 18ms 4ms maximum plus filter time
Diagnostic Functions Open wire Time stamp of diagnostics Change of state Timestamp on inputs	Off-state leakage current 1.2mA minimum +/- 1ms Software configurable +/- 200 $\mu$ s
Cyclic Update Time	User selectable (200 $\mu$ s minimum/750ms maximum)
Reverse Polarity Protection	Yes
Maximum Inrush Current	250mA
Isolation Voltage Group to group User to system	100% tested at 2546V dc for 1s (250V ac maximum continuous voltage) 100% tested at 2546V dc for 1s (250V ac maximum continuous voltage)
Module Keying (Backplane)	Software configurable
RTB Screw Torque (Cage clamp)	4.4 inch-pounds (0.4Nm) maximum
RTB Keying	User defined mechanical keying
RTB and Housing	36 Position RTB (1756-TBCH or TBS6H) <sup>1</sup>
Environmental Conditions Operating Temperature Storage Temperature Relative Humidity	0 to 60°C (32 to 140°F) -40 to 85°C (-40 to 185°F) 5 to 95% noncondensing
Conductors    Wire Size Category	22-14 gauge (2mm <sup>2</sup> ) stranded <sup>1</sup> 3/64 inch (1.2mm) insulation maximum 1, 2, 3
Screwdriver Blade Width for RTB	1/8 inch (3.2mm) maximum
Agency Certification (when product or packaging is marked)	 Listed Industrial Control Equipment  Certified Process Control Equipment Certified Class I, Division 2, Group A, B, C, D  Approved Class I, Division 2, Group A, B, C, D  Marked for all applicable directives  Marked for all applicable acts N223

<sup>1</sup> Maximum wire size will require extended housing - 1756-TBE.

<sup>2</sup> Use this conductor category information for planning conductor routing as described in the system level installation manual.

<sup>3</sup> Refer to publication 1770-4.1 "Industrial Automation Wiring and Grounding Guidelines".

# 1756-IB16I

## Configurable features

The following table lists the configurable features this module supports, the default value and the page of the feature's description:

Feature	Default value	Page of description
Change of State (COS)	OFF-ON: Enabled ON-OFF: Enabled	2-10
Software Configurable Filter Times	OFF-ON: 1ms ON-OFF: 1ms	3-11
Communications Format	Input data	6-6

## Wiring example

Use the following example to wire your module.

- NOTES:
1. All terminals with the same name are connected together on the module. For example, DC(-) can be connected to either terminal marked GND-15.
  2. Do not physically connect more than two wires to a single RTB terminal. When you use the second GND-15 terminal to daisy chain to other RTBs, always connect the daisy chain as shown.
  3. Each input can be wired in a sink or source configuration as shown.
  4. The **jumper bar** part number is 97739201. Contact your local Rockwell Automation sales representative to order additional jumper bars, if necessary.
  5. If separate power sources are used, do not exceed the specified isolation voltage.

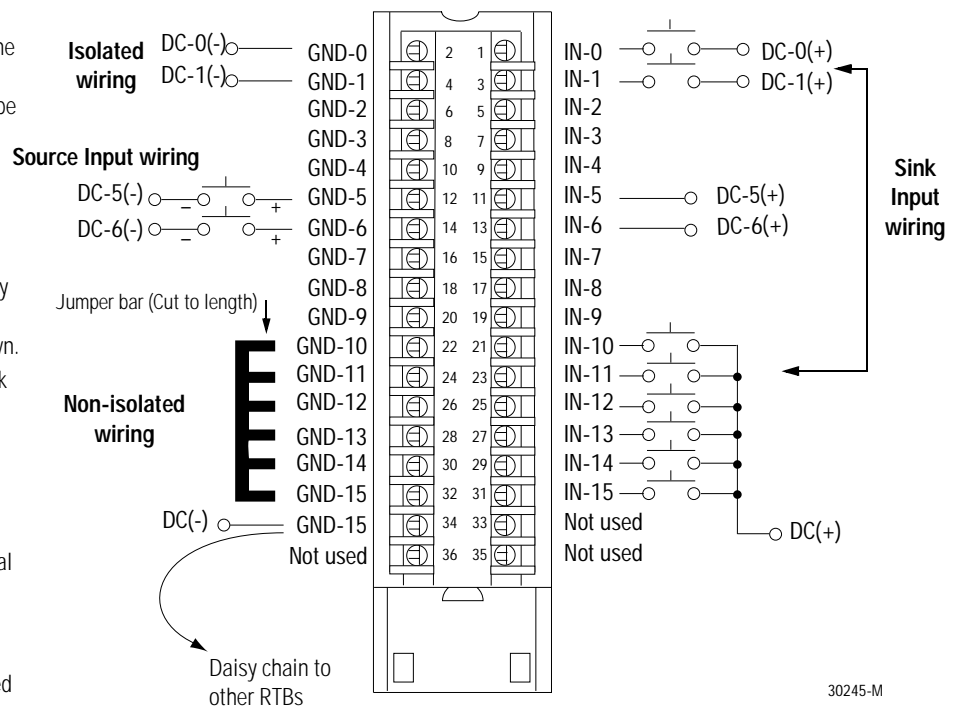

30245-M

### Simplified schematic

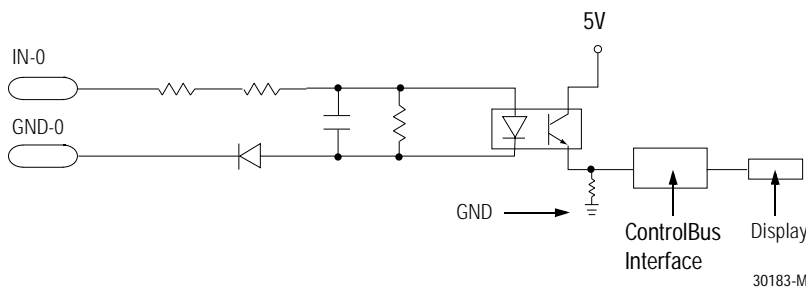



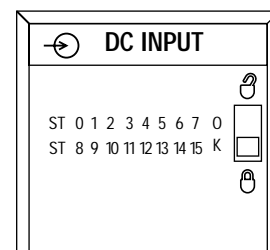

30183-M

### LED indicator



20945-M

## 1756-IB16I Specifications

Number of Inputs	16 (individually isolated)
Module Location	1756 ControlLogix Chassis
Backplane Current	100mA @ 5.1V dc & 3mA @ 24V dc (Total backplane power 0.58W)
Maximum Power Dissipation (Module)	5W @ 60°C
Thermal Dissipation	17.05 BTU/hr
On-State Voltage Range	10-30V dc
Nominal Input Voltage	24V dc
On-State Current	2mA @ 10V dc minimum 10mA @ 30 V dc maximum
Maximum Off-State Voltage	5V dc
Maximum Off-State Current	1.5mA
Max. Input Impedance @ 30V dc	3kΩ
Input Delay Time OFF to ON Hardware delay ON to OFF Hardware delay	Programmable filter: 0ms, 1ms or 2ms 1ms maximum plus filter time Programmable filter: 0ms, 1ms, 2ms, 9ms or 18ms 4ms maximum plus filter time
Diagnostic Functions Change of state Time stamp of inputs	Software configurable +/- 200μs
Maximum Inrush Current	250mA
Cyclic Update Time	User selectable (100μs minimum/750ms maximum)
Reverse Polarity Protection	Yes
Isolation Voltage Channel to channel User side to system side	100% tested at 2546V dc for 1 second (250V ac max. continuous voltage) 100% tested at 2546V dc for 1 second (250V ac max. continuous voltage)
Module Keying (Backplane)	Software configurable
RTB Screw Torque (Cage clamp)	4.4 inch-pounds (0.4Nm) maximum
RTB Keying	User defined mechanical keying
RTB and Housing	36 Position RTB (1756-TBCH or TBS6H) <sup>1</sup>
Environmental Conditions Operating Temperature Storage Temperature Relative Humidity	0 to 60°C (32 to 140°F) -40 to 85°C (-40 to 185°F) 5 to 95% noncondensing
Conductors    Wire Size Category	22–14 gauge (2mm <sup>2</sup> ) stranded <sup>1</sup> 3/64 inch (1.2mm) insulation maximum <sup>1, 2, 3</sup>
Screwdriver Blade Width for RTB	1/8 inch (3.2mm) maximum
Agency Certification (when product or packaging is marked)	 Listed Industrial Control Equipment  Certified Process Control Equipment Certified Class I, Division 2, Group A, B, C, D  Approved Class I, Division 2, Group A, B, C, D  Marked for all applicable directives  Marked for all applicable acts N223

<sup>1</sup> Maximum wire size will require extended housing - 1756-TBE.

<sup>2</sup> Use this conductor category information for planning conductor routing as described in the system level installation manual.

<sup>3</sup> Refer to publication 1770-4.1 "Industrial Automation Wiring and Grounding Guidelines".

# 1756-IB32

## Configurable features

The following table lists the configurable features this module supports, the default value and the page of the feature's description:

Feature	Default value	Page of description
Change of State (COS)	OFF-ON: Enabled ON-OFF: Enabled	2-10
Software Configurable Filter Times	OFF-ON: 1ms ON-OFF: 1ms	3-11
Communications Format	Input data	6-6



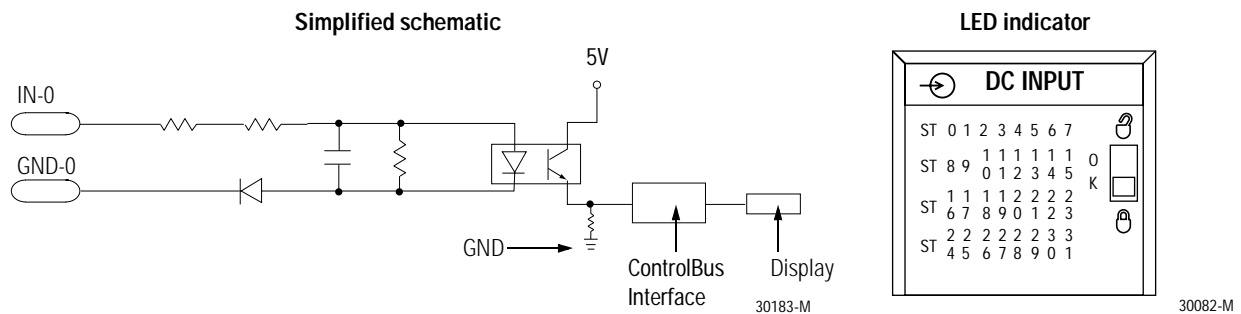
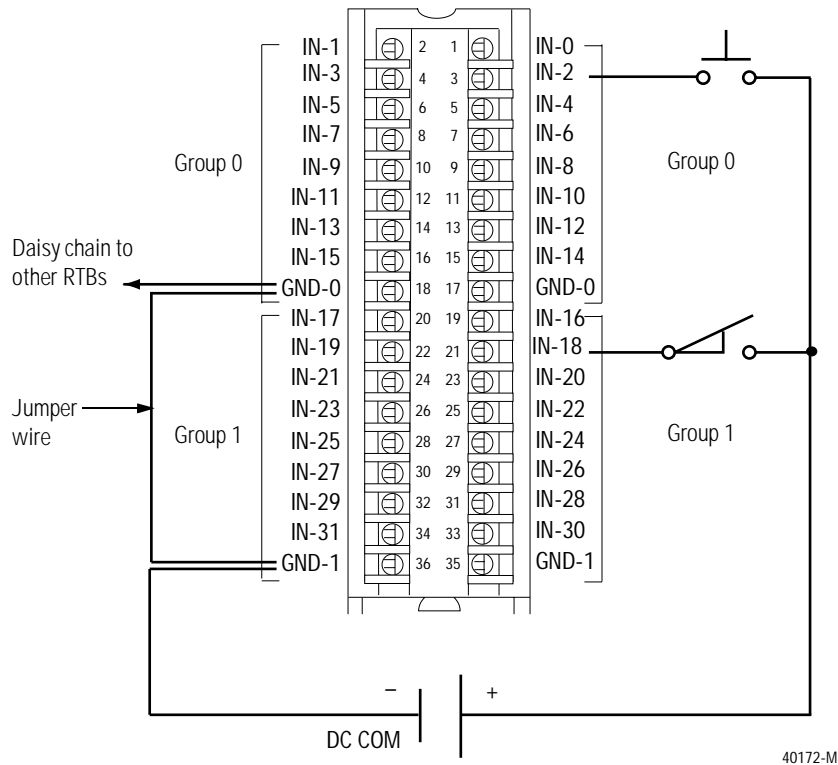

## Wiring example

Use the following example to wire your module.

- NOTES: 1. All terminals with the same name are connected together on the module. For example, DC COM can be connected to either terminal marked GND-1.
2. Do not physically connect more than two wires to a single RTB terminal. When you daisy chain to other RTBs, always connect the daisy chain as shown.
3. This wiring example shows a single voltage source.
4. If separate power sources are used, do not exceed the specified isolation voltage.



## 1756-IB32 Specifications

Number of Inputs	32 (16 points/common)
Module Location	1756 ControlLogix Chassis
Backplane Current	150mA @ 5.1V dc & 2mA @ 24V dc (Total backplane power 0.81W)
Maximum Power Dissipation (Module)	4.5W @ 60°C
Thermal Dissipation	16.37 BTU/hr @ 60°C
On-State Voltage Range	10-31.2V dc
Nominal Input Voltage	24V dc
ON-State Current @ 10V dc @ 31.2V dc	2 mA 5.5mA
Maximum Off-State Voltage	5V dc
Maximum Off-State Current	1.5mA
Maximum Input Impedance @ 31.2V dc	5.67k $\Omega$
Input Delay Time OFF to ON Hardware delay ON to OFF Hardware delay	Programmable filter: 0ms, 1ms or 2ms 1ms maximum plus filter time Programmable filter: 0ms, 1ms, 2ms, 9ms or 18ms 2ms maximum plus filter time
Diagnostic Functions Change of state Time stamp on inputs	Software configurable +/- 200 $\mu$ s
Maximum Inrush Current	250mA
Cyclic Update Time	User selectable (100 $\mu$ s minimum/750ms maximum)
Reverse Polarity Protection	Yes
Isolation Voltage Group to group User to system	100% tested at 2546V dc for 1s (250V ac max. continuous voltage) 100% tested at 2546V dc for 1s (250V ac max. continuous voltage)
RTB Screw Torque (Cage clamp)	4.4 inch-pounds (0.4Nm) maximum
Module Keying (Backplane)	Software configurable
RTB Keying	User defined mechanical keying
Field Wiring Arm and Housing	36 Position RTB (1756-TBCH or TBS6H) <sup>1</sup>
Environmental Conditions Operating Temperature Storage Temperature Relative Humidity	0 to 60°C (32 to 140°F) -40 to 85°C (-40 to 185°F) 5 to 95% noncondensing
Conductors Wire Size Category	22-14 gauge (2mm <sup>2</sup> ) stranded <sup>1</sup> 3/64 inch (1.2mm) insulation maximum <sup>1,2,3</sup>
Screwdriver Blade Width for RTB	1/8 inch (3.2mm) maximum
Agency Certification (when product or packaging is marked)	 Listed Industrial Control Equipment  Certified Process Control Equipment Certified Class I, Division 2, Group A, B, C, D  Approved Class I, Division 2, Group A, B, C, D  Marked for all applicable directives  Marked for all applicable acts N223

<sup>1</sup> Maximum wire size will require extended housing - 1756-TBE.

<sup>2</sup> Use this conductor category information for planning conductor routing as described in the system level installation manual.

<sup>3</sup> Refer to publication 1770-4.1 'Industrial Automation Wiring and Grounding Guidelines'.

# 1756-IC16

## Configurable features

The following table lists the configurable features this module supports, the default value and the page of the feature's description:

Feature	Default value	Page of description
Change of State (COS)	OFF-ON: Enabled ON-OFF: Enabled	2-10
Software Configurable Filter Times	OFF-ON: 1ms ON-OFF: 1ms	3-11
Communications Format	Input data	6-6

## Wiring example

Use the following example to wire your module.

- NOTES:
1. All terminals with the same name are connected together on the module. For example, DC COM can be connected to any terminal marked GND-1.
  2. Do not physically connect more than two wires to a single RTB terminal. When you daisy chain from a group to another RTB, always connect the daisy chain as shown.
  3. This wiring example shows a single voltage source.
  4. If separate power sources are used, do not exceed the specified isolation voltage.

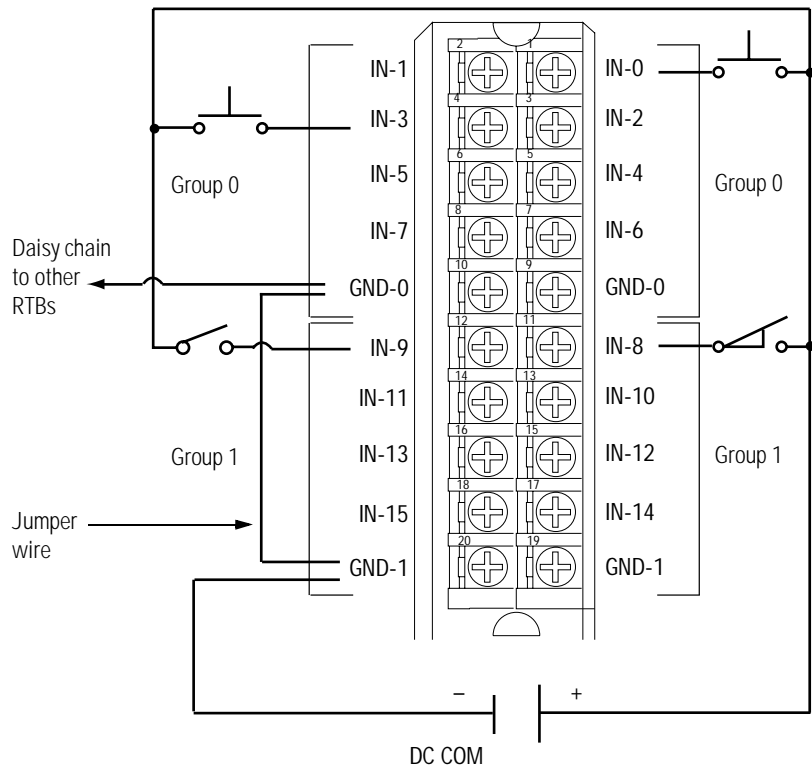



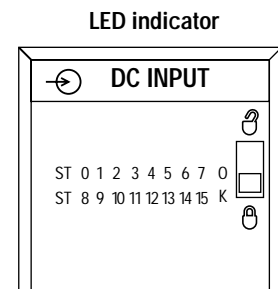
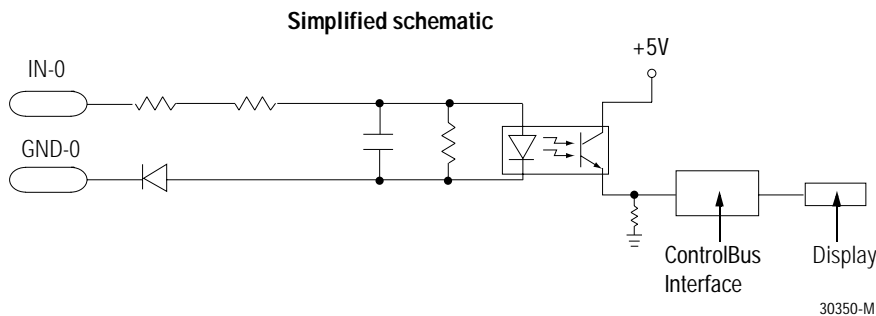

40179-M



30350-M

20945-M

## 1756-IC16 Specifications

Number of Inputs	16 (8 points/common)
Module Location	1756 ControlLogix Chassis
Backplane Current	100mA @ 5.1V dc & 3mA @ 24V dc (Total backplane power 0.58W)
Maximum Power Dissipation (Module)	5.2W @ 60°C
Thermal Dissipation	17.73 BTU/hr
On-State Voltage Range	30-55V dc @ 60°C all channels (Linear derating) 30-60V dc @ 55°C all channels (Linear derating)
Nominal Input Voltage	48V dc
On-State Current	2mA @ 30V dc minimum 7mA @ 60V dc maximum
Maximum Off-State Voltage	10V
Maximum Off-State Current	1.5mA
Maximum Input Impedance @ 60V dc	8.57k $\Omega$
Input Delay Time OFF to ON Hardware delay ON to OFF Hardware delay	Programmable filter: 0ms, 1ms, or 2ms 1ms maximum plus filter time Programmable filter: 0ms, 1ms, 2ms, 9ms, or 18ms 4ms maximum plus filter time
Diagnostic Functions Change of state Time stamp of inputs	Software configurable +/- 200 $\mu$ s
Cyclic Update Time	User selectable (200 $\mu$ s minimum/750ms maximum)
Reverse Polarity Protection	Yes
Maximum Inrush Current	250mA
Isolation Voltage Group to group User to system	100% tested at 2546V dc for 1s (250V ac max. continuous voltage) 100% tested at 2546V dc for 1s (250V ac max. continuous voltage)
Module Keying (Backplane)	Software configurable
RTB Screw Torque (NEMA)	7-9 inch-pounds (0.8-1Nm)
RTB Keying	User defined mechanical keying
RTB and Housing	20 Position RTB (1756-TBNH or TBSH) <sup>1</sup>
Environmental Conditions Operating Temperature Storage Temperature Relative Humidity	0 to 60°C (32 to 140°F) -40 to 85°C (-40 to 185°F) 5 to 95% noncondensing
Conductors     Wire Size  Category	22–14 gauge (2mm <sup>2</sup> ) stranded <sup>1</sup> 3/64 inch (1.2mm) insulation maximum 1 <sup>2, 3</sup>
Screwdriver Blade Width for RTB	5/16 inch (8mm) maximum
Agency Certification (when product or packaging is marked)	 Listed Industrial Control Equipment  Certified Process Control Equipment Certified Class I, Division 2, Group A, B, C, D  Approved Class I, Division 2, Group A, B, C, D  Marked for all applicable directives  Marked for all applicable acts N223

<sup>1</sup> Maximum wire size will require extended housing - 1756-TBE.

<sup>2</sup> Use this conductor category information for planning conductor routing as described in the system level installation manual.

<sup>3</sup> Refer to publication 1770-4.1 "Industrial Automation Wiring and Grounding Guidelines".

# 1756-IH16I

## Configurable features

The following table lists the configurable features this module supports, the default value and the page of the feature's description:

Feature	Default value	Page of description
Change of State (COS)	OFF-ON: Enabled ON-OFF: Enabled	2-10
Software Configurable Filter Times	OFF-ON: 1ms ON-OFF: 1ms	3-11
Communications Format	Input data	6-6

## Wiring example

Use the following example to wire your module.

- NOTES:
1. All terminals with the same name are connected together on the module. For example, DC(-) can be connected to either terminal marked GND-15.
  2. Do not physically connect more than two wires to a single RTB terminal. When you use the second GND-15 terminal to daisy chain to other RTBs, always connect the daisy chain to the terminal directly connected to the supply wire as shown.
  3. The **jumper bar** part number is 97739201. Contact your local Rockwell Automation sales representative to order additional jumper bars, if necessary.
  4. If separate power sources are used, do not exceed the specified isolation voltage.

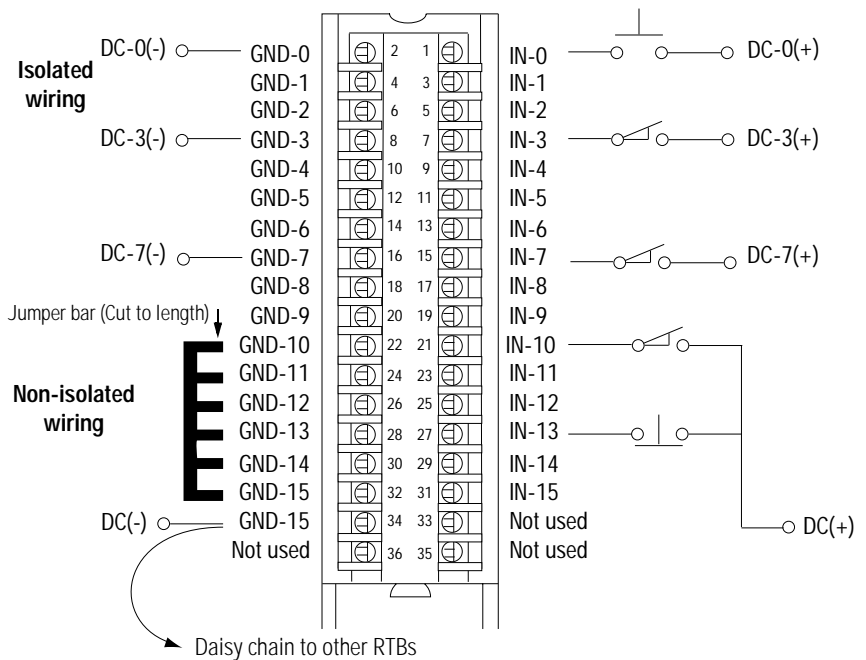



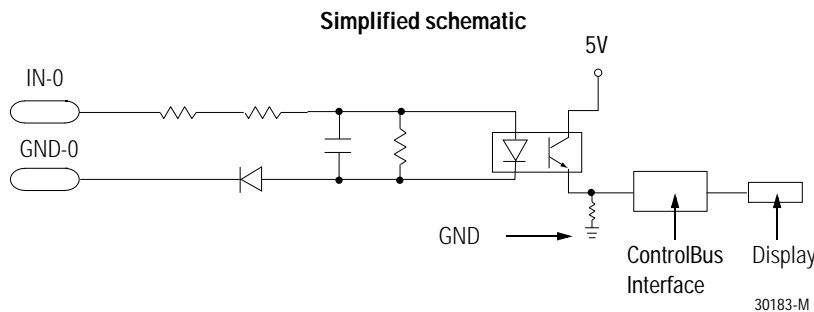

40167-M



30183-M

20945-M

## 1756-IH16I Specifications

Number of Inputs	16 (Individually isolated)
Module Location	1756 ControlLogix Chassis
Backplane Current	125mA @ 5.1V dc & 3mA @ 24V dc (Total backplane power 0.71W)
Max. Power Dissipation (Module)	5W @ 60°C
Thermal Dissipation	17.05 BTU/hr
On-State Voltage Range Derated as follows	90-146V dc 90-146V dc @ 50°C, 12 Channels ON @ same time 90-132V dc @ 55°C, 14 Channels ON @ same time 90-125V dc @ 60°C, 16 Channels ON @ same time 90-146V dc @ 30°C, 16 Channels ON @ same time
Nominal Input Voltage	125V dc
On-State Current	1mA @ 90V dc minimum 3mA @ 146V dc maximum
Maximum Off-State Voltage	20V dc
Maximum Off-State Current	0.8mA
Maximum Input Impedance @ 146V dc	48.67k $\Omega$
Input Delay Time OFF to ON Hardware delay ON to OFF Hardware delay	Programmable filter: 0ms, 1ms or 2ms 2ms maximum plus filter time Programmable filter: 0ms, 1ms, 2ms, 9ms or 18ms 6ms maximum plus filter time
Diagnostic Functions Change of state Time stamp of inputs	Software configurable +/- 200 $\mu$ s
Maximum Inrush Current	250mA
Cyclic Update Time	User selectable (200 $\mu$ s minimum/750ms maximum)
Reverse Polarity Protection	Yes
Isolation Voltage Channel to channel User to system	100% tested at 2546V dc for 1s (250V ac max. continuous voltage) 100% tested at 2546V dc for 1s (250V ac max. continuous voltage)
RTB Screw Torque (Cage clamp)	4.4 inch-pounds (0.4Nm) maximum
Module Keying (Backplane)	Software configurable
RTB Keying	User defined mechanical keying
RTB and Housing	36 Position RTB (1756-TBCH or TBS6H) <sup>1</sup>
Environmental Conditions Operating Temperature Storage Temperature Relative Humidity	0 to 60°C (32 to 140°F) -40 to 85°C (-40 to 185°F) 5 to 95% noncondensing
Conductors    Wire Size  Category	22–14 gauge (2mm <sup>2</sup> ) stranded <sup>1</sup> 3/64 inch (1.2mm) insulation maximum <sup>1,2,3</sup>
Screwdriver Blade Width for RTB	1/8 inch (3.2mm) maximum
Agency Certification (when product or packaging is marked)	 Listed Industrial Control Equipment  Certified Process Control Equipment Certified Class I, Division 2, Group A, B, C, D  Approved Class I, Division 2, Group A, B, C, D  Marked for all applicable directives  Marked for all applicable acts N223

<sup>1</sup> Maximum wire size will require extended housing - 1756-TBE.

<sup>2</sup> Use this conductor category information for planning conductor routing as described in the system level installation manual.

<sup>3</sup> Refer to publication 1770-4.1 'Industrial Automation Wiring and Grounding Guidelines'.

# 1756-IM16I

## Configurable features

The following table lists the configurable features this module supports, the default value and the page of the feature's description:

Feature	Default value	Page of description
Change of State (COS)	OFF-ON: Enabled ON-OFF: Enabled	2-10
Software Configurable Filter Times	OFF-ON: 1ms ON-OFF: 1ms	3-11
Communications Format	Input data	6-6

## Wiring example

Use the following example to wire your module.

- NOTES: **1.** All terminals with the same name are connected together on the module. For example, L2 can be connected to any terminal marked L2-15.
- 2.** Do not physically connect more than two wires to a single RTB terminal. When you use the second L2-15 terminal to daisy chain to other RTBs, always connect the daisy chain as shown.
- 3.** The **jumper bar** part number is 97739201. Contact your local Rockwell Automation sales representative to order additional jumper bars, if necessary.
- 4.** If separate power sources are used, do not exceed the specified isolation voltage.

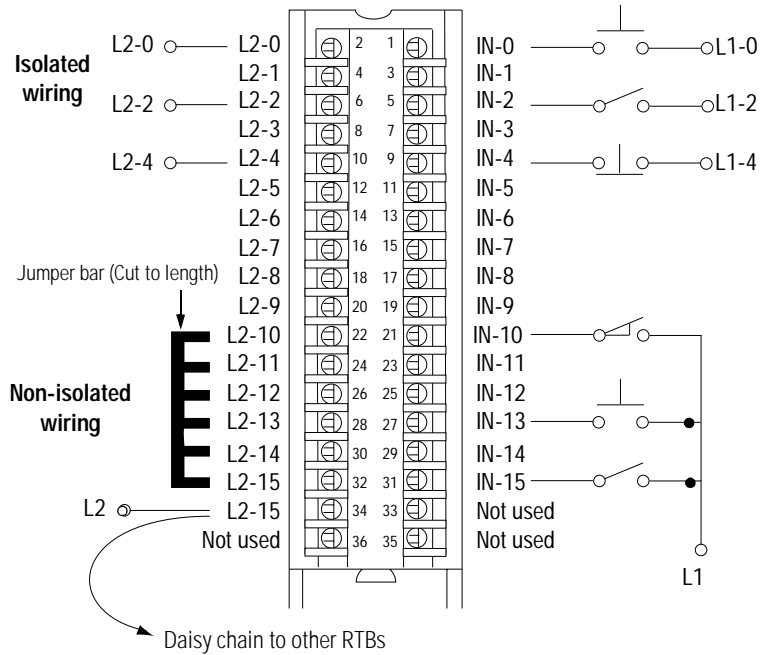

40168-M

### Simplified schematic

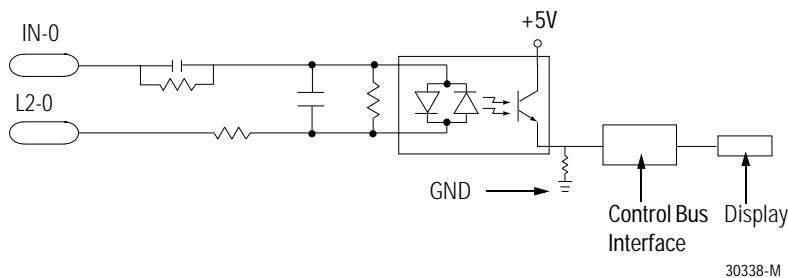

30338-M

### LED indicator

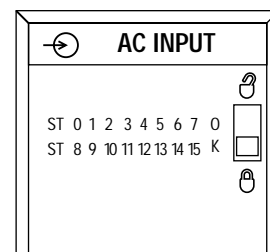

20941-M



# 1756-IN16

## Configurable features

The following table lists the configurable features this module supports, the default value and the page of the feature's description:

Feature	Default value	Page of description
Change of State (COS)	OFF-ON: Enabled ON-OFF: Enabled	2-10
Software Configurable Filter Times	OFF-ON: 1ms ON-OFF: 1ms	3-11
Communications Format	Input data	6-6

## Wiring example

Use the following example to wire your module.

- NOTES: 1. All terminals with the same name are connected together on the module. For example, L2 can be connected to any terminal marked L2-0.
2. Do not physically connect more than two wires to a single RTB terminal. When you daisy chain from a group to another RTB, always connect the daisy chain as shown.
3. This wiring example shows a single voltage source.
4. If separate power sources are used, do not exceed the specified isolation voltage.

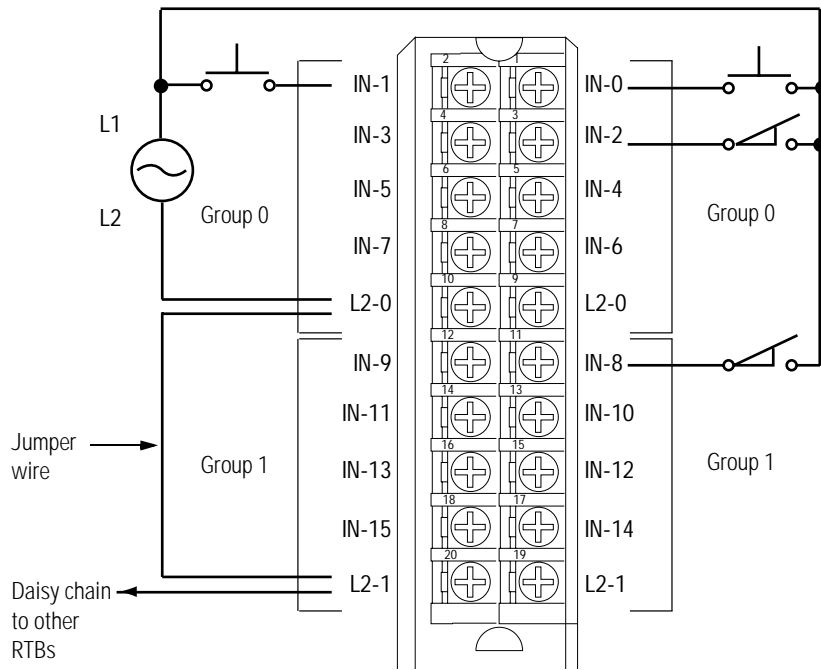



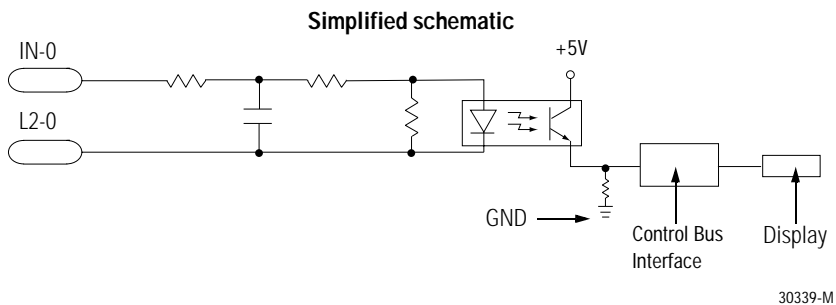

40180-M



30339-M

20941-M

## 1756-IN16 Specifications

Number of Inputs	16 (8 points/common)
Module Location	1756 ControlLogix Chassis
Backplane Current	100mA @ 5.1V dc & 2mA @ 24V dc (Total backplane power 0.56W)
Maximum Power Dissipation (Module)	5.1W @ 60°C
Thermal Dissipation	17.39 BTU/hr
On-State Voltage Range	10-30V ac, 47-63Hz
Nominal Input Voltage	24V ac
On-State Current	5mA @ 10V ac, 60Hz minimum 1.2mA @ 30V ac, 60Hz maximum
Maximum Off-State Voltage	5V
Maximum Off-State Current	2.75mA
Maximum Input Impedance @ 30V ac	2.5kΩ @ 60Hz
Input Delay Time Off to on Hardware delay On to off Hardware delay	Programmable filter: 0ms, 1ms or 2ms 10ms maximum plus filter time Programmable filter: 9ms or 18ms 10ms maximum plus filter time
Diagnostic Functions Change of state Time stamp of inputs	Software configurable +/- 200μs
Max. Inrush Current	250mA
Cyclic Update Time	User Selectable (200μs minimum/750ms maximum)
Isolation Voltage Group to group User to system	100% tested at 2546V dc for 1s (250V ac max. continuous voltage) 100% tested at 2546V dc for 1s (250V ac max. continuous voltage)
Module Keying (Backplane)	Software configurable
RTB Screw Torque (NEMA)	7-9 inch-pounds (0.8–1Nm)
RTB Keying	User defined mechanical keying
RTB and Housing	20 Position RTB (1756-TBNH or TBSH) <sup>1</sup>
Environmental Conditions Operating Temperature Storage Temperature Relative Humidity	0 to 60°C (32 to 140°F) -40 to 85°C (-40 to 185°F) 5 to 95% noncondensing
Conductors    Wire Size Category	22–14 gauge (2mm <sup>2</sup> ) stranded <sup>1</sup> 3/64 inch (1.2mm) insulation maximum <sup>1,2,3</sup>
Screwdriver Blade Width for RTB	5/16 inch (8mm) maximum
Agency Certification (when product or packaging is marked)	 Listed Industrial Control Equipment  Certified Process Control Equipment Certified Class I, Division 2, Group A, B, C, D  Approved Class I, Division 2, Group A, B, C, D  Marked for all applicable directives  Marked for all applicable acts N223

<sup>1</sup> Maximum wire size will require extended housing - 1756-TBE.

<sup>2</sup> Use this conductor category information for planning conductor routing as described in the system level installation manual.

<sup>3</sup> Refer to publication 1770-4.1 "Industrial Automation Wiring and Grounding Guidelines".

# 1756-IV16

## Configurable Features

The following table lists the configurable features this module supports, the default value and the page of the feature's description:

Feature	Default value	Page of description
Change of State (COS)	OFF-ON: Enabled ON-OFF: Enabled	2-10
Software Configurable Filter Times	OFF-ON: 1ms ON-OFF: 1ms	3-11
Communications Format	Input data	6-6

## Wiring example

Use the following example to wire your module.

- NOTES:
1. All terminals with the same name are connected together on the module. For example, DC (+) can be connected to either terminal marked DC-1+.
  2. Do not physically connect more than two wires to a single RTB terminal. When you daisy chain from a group to another RTB, always connect the daisy chain as shown.
  3. This wiring example shows a single voltage source.
  4. If separate power sources are used, do not exceed the specified isolation voltage.

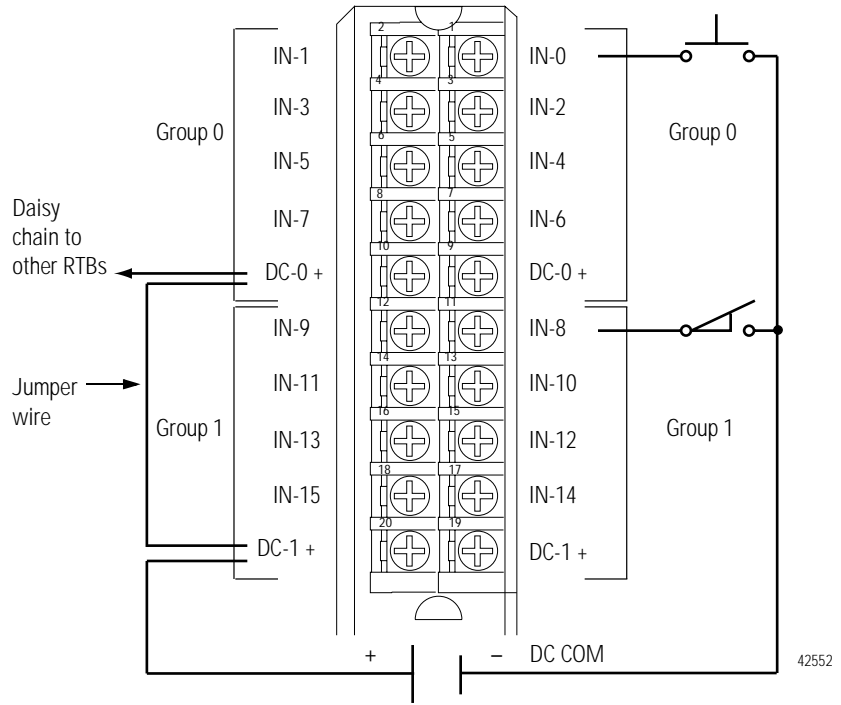



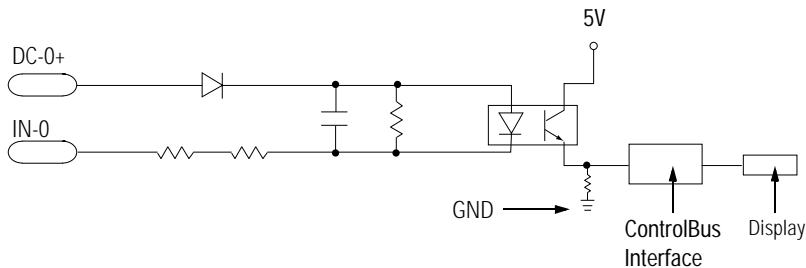

Simplified schematic

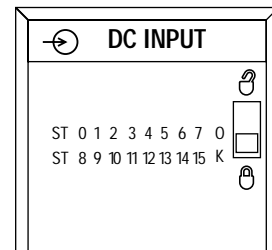

LED indicator



## 1756-IV16 Specifications

Number of Inputs	16 (8 points/common)
Module Location	1756 ControlLogix Chassis
Backplane Current	110mA @ 5.1V dc & 2mA @ 24V dc (Total backplane power 0.61W)
Maximum Power Dissipation (Module)	5.41W @ 60°C
Thermal Dissipation	18.47 BTU/hr
On-State Voltage Range	10-30V dc
Nominal Input Voltage	24V dc
On-State Current	2.0mA @ 10V dc minimum 10mA @ 30V dc maximum
Maximum Off-State Voltage	5V
Maximum Off-State Current	1.5mA
Maximum Input Impedance @ 30V dc	3.2kΩ
Input Delay Time OFF to ON Hardware delay ON to OFF Hardware delay	Programmable filter: 0ms, 1ms or 2ms 1ms maximum plus filter time Programmable filter: 0ms, 1ms, 2ms, 9ms or 18ms 2ms maximum plus filter time
Diagnostic Functions Change of State Timestamp of Inputs	Software configurable +/- 200μs
Maximum Inrush Current	250mA
Cyclic Update Time	User selectable (100μs minimum/750ms maximum)
Reverse Polarity Protection	Yes
Isolation Voltage Group to group User to system	100% tested at 2546V dc for 1s (250V ac max. continuous voltage) 100% tested at 2546V dc for 1s (250V ac max. continuous voltage)
RTB Screw Torque (NEMA clamp)	7-9 inch-pounds (0.8-1Nm)
Module Keying (Backplane)	Software configurable
RTB Keying	User defined mechanical keying
Field Wiring Arm	20 Position RTB (1756-TBNH or TBSH) <sup>1</sup>
Environmental Conditions Operating Temperature Storage Temperature Relative Humidity	0 to 60°C (32 to 140°F) -40 to 85°C (-40 to 185°F) 5 to 95% noncondensing
Conductors    Wire Size Category	22-14 gauge (2mm <sup>2</sup> ) stranded <sup>1</sup> 3/64 inch (1.2mm) insulation maximum <sup>1, 2, 3</sup>
Screwdriver Blade Width for RTB	5/16 inch (8mm) maximum
Agency Certification (when product is marked)	 Listed Industrial Control Equipment  Certified Process Control Equipment Certified Class I, Division 2, Group A, B, C, D  Approved Class I, Division 2, Group A, B, C, D  Marked for all applicable directives  Marked for all applicable acts N223

<sup>1</sup> Maximum wire size will require extended housing - 1756-TBE.

<sup>2</sup> Use this conductor category information for planning conductor routing as described in the system level installation manual.

<sup>3</sup> Refer to publication 1770-4.1 "Industrial Automation Wiring and Grounding Guidelines".

# 1756-IV32

## Configurable features

The following table lists the configurable features this module supports, the default value and the page of the feature's description:

Feature	Default value	Page of description
Change of State (COS)	OFF-ON: Enabled ON-OFF: Enabled	2-10
Software Configurable Filter Times	OFF-ON: 1ms ON-OFF: 1ms	3-11
Communications Format	Input data	6-6

## Wiring example

Use the following example to wire your module.

- NOTES:
1. All terminals with the same name are connected together on the module. For example, DC COM can be connected to either terminal marked GND-1.
  2. Do not physically connect more than two wires to a single RTB terminal. When you daisy chain to other RTBs, always connect the daisy chain as shown.
  3. This wiring example shows a single voltage source.
  4. If separate power sources are used, do not exceed the specified isolation voltage.

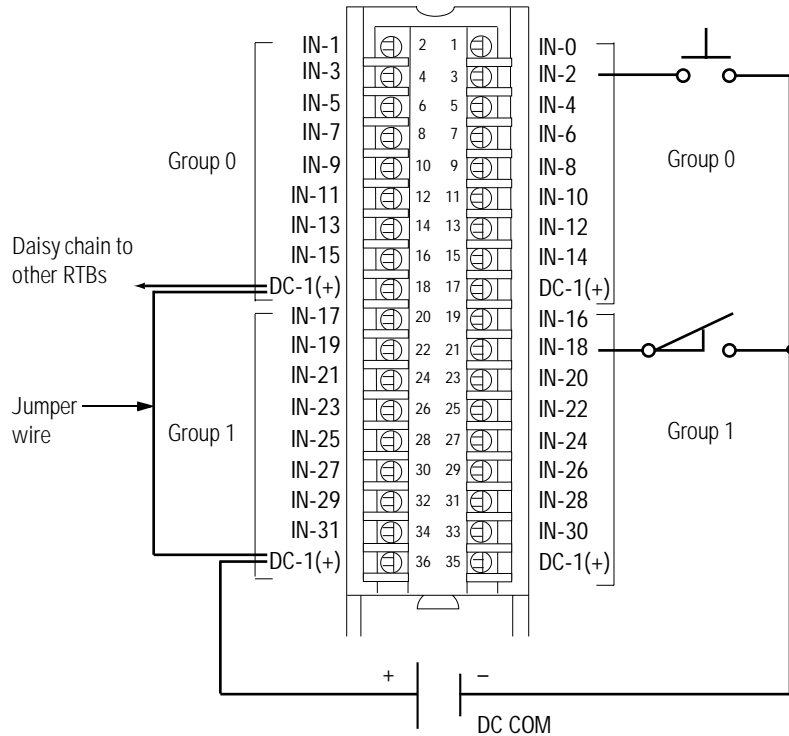



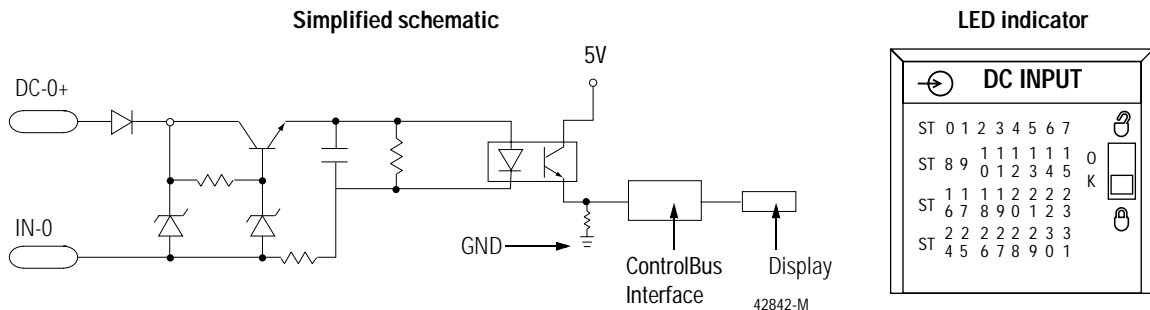

42573



30082-M

## 1756-IV32 Specifications

Number of Inputs	32 (16 points/common)
Module Location	1756 ControlLogix Chassis
Backplane Current	120mA @ 5.1V dc & 2mA @ 24V dc (Total backplane power 0.66W)
Maximum Power Dissipation (Module)	4.1W @ 60°C
Thermal Dissipation	14 BTU/hr @ 60°C
On-State Voltage Range	10-30V dc
Nominal Input Voltage	24V dc
ON-State Current @ 10V dc @ 30V dc	2mA 3.5mA
Maximum Off-State Voltage	5V dc
Maximum Off-State Current	1.5mA
Maximum Input Impedance @ 30V dc	8.6kΩ
Input Delay Time OFF to ON Hardware delay ON to OFF Hardware delay	Programmable filter: 0ms, 1ms or 2ms 1ms maximum plus filter time Programmable filter: 0ms, 1ms, 2ms, 9ms or 18ms 2ms maximum plus filter time
Diagnostic Functions Change of state Timestamp on inputs	Software configurable +/- 200μs
Short/Inrush Current	250mA peak (decaying to <37% in 22ms, without activation)
Cyclic Update Time	User selectable (100μs minimum/750ms maximum)
Reverse Polarity Protection	Yes
Isolation Voltage Group to group  User to system	100% tested at 2546V dc for 1s (250V ac max. continuous voltage between groups) 100% tested at 2546V dc for 1s
RTB Screw Torque (Cage clamp)	4.4 inch-pounds (0.4Nm) maximum
Module Keying (Backplane)	Software configurable
RTB Keying	User-defined mechanical keying
Field Wiring Arm and Housing	36 Position RTB (1756-TBCH or TBS6H) <sup>1</sup>
Environmental Conditions Operating Temperature Storage Temperature Relative Humidity	0 to 60°C (32 to 140°F) -40 to 85°C (-40 to 185°F) 5 to 95% noncondensing
Conductors    Wire Size  Category	22-14 gauge (2mm <sup>2</sup> ) stranded <sup>1</sup> 3/64 inch (1.2mm) insulation maximum <sup>1,2,3</sup>
Screwdriver Blade Width for RTB	1/8 inch (3.2mm) maximum
Agency Certification (when product or packaging is marked)	 Listed Industrial Control Equipment  Certified Process Control Equipment Certified Class I, Division 2, Group A, B, C, D  Approved Class I, Division 2, Group A, B, C, D  Marked for all applicable directives  Marked for all applicable acts N223

<sup>1</sup> Maximum wire size will require extended housing - 1756-TBE.

<sup>2</sup> Use this conductor category information for planning conductor routing as described in the system level installation manual.

<sup>3</sup> Refer to publication 1770-4.1 "Industrial Automation Wiring and Grounding Guidelines".

# 1756-OA16

## Configurable features

The following table lists the configurable features this module supports, the default value and the page of the feature's description:

Feature	Default value	Page of description
Communications Format	CST timestamped fuse data - output data	6-6
Program Mode	Off	6-11
Communications Failure in Program Mode	Disabled	6-11
Fault Mode	Off	6-11





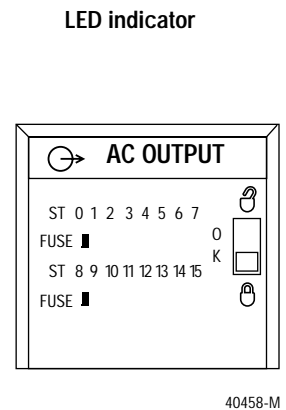
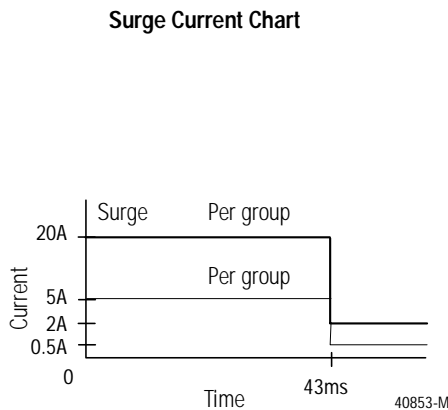
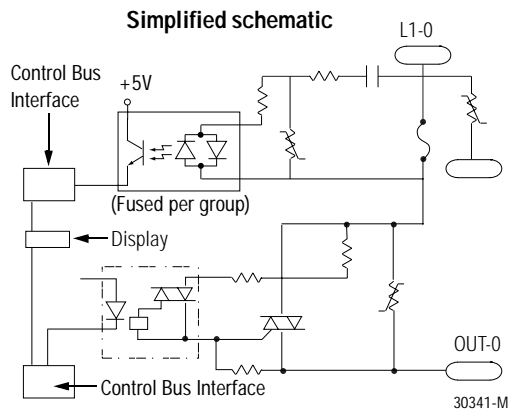
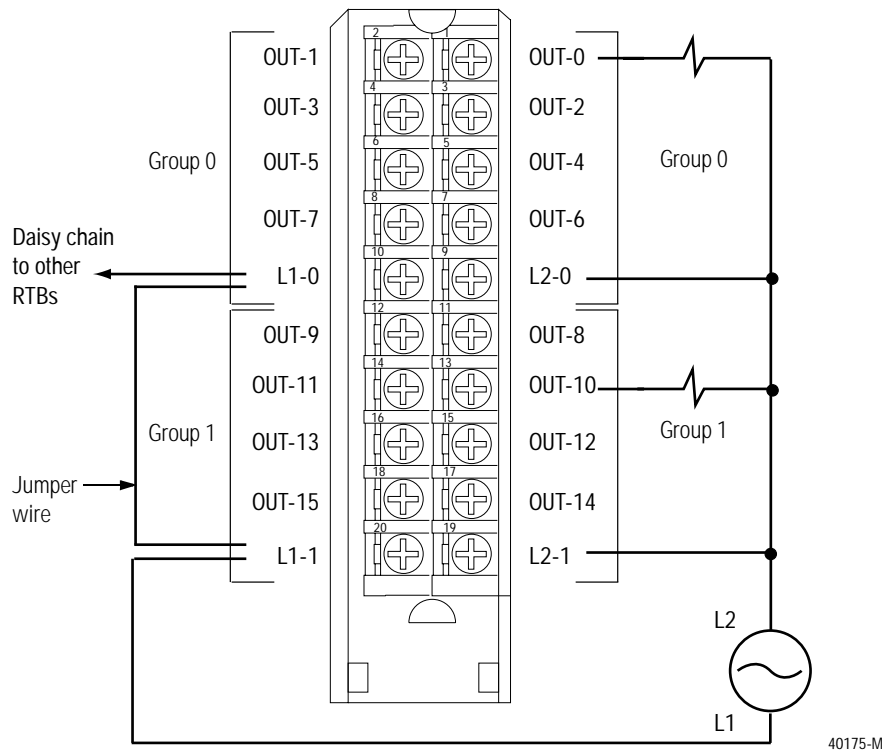

## Wiring example

Use the following example to wire your module.

- NOTES: **1.** Do not physically connect more than two wires to a single RTB terminal. When you daisy chain from a group to other RTBs, always connect the daisy chain as shown.
- 2.** This wiring example shows a single voltage source.
- 3.** If separate power sources are used, do not exceed the specified isolation voltage.



## 1756-OA16 Specifications

Number of Outputs	16 (8 points/common)
Module Location	1756 ControlLogix Chassis
Backplane Current	400mA @ 5.1V dc & 2mA @ 24V dc (Total backplane power 2.1W)
Max. Power Dissipation (Module)	6.5W @ 60°C
Thermal Dissipation	22.17 BTU/hr
Output Voltage Range	74-265V ac, 47-63Hz
Output Current Rating	
Per Point	0.5A maximum @ 60°C
Per Group	2A maximum @ 60°C
Per Module	4A maximum @ 60°C
Surge Current	
Per Point	5A for 43ms each, repeatable every 2s @ 60°C
Per Group	15A for 43ms each, repeatable every 2s @ 60°C
Minimum Load Current	10mA per point
Maximum On-State Voltage Drop	1.5V @ 0.5A 5.7V @ load current < 50mA
Max. Off-State Leakage Current	3mA per point
Commutating Voltage	4V/μs for loads>50mA 0.2V/μs for loads<50mA <sup>1</sup>
Output Delay Time	
OFF to ON	9.3ms @ 60Hz; 11ms @ 50Hz
ON to OFF	9.3ms @ 60Hz; 11ms @ 50Hz
Diagnostic Functions	
Fuse Blown	1 Fuse and indicator/group
Time stamp of diagnostics	+/- 1ms
Scheduled Outputs	Synchronization within 16.7s maximum, reference to the CST
Configurable Fault States per Point	Hold Last State, ON or OFF (OFF is the default)
Configurable States in Program Mode per Point	Hold Last State, ON or OFF (OFF is the default)
Maximum Inhibit Voltage	Zero crossing 60V peak
Fusing	Mechanically fused/group 3.15A @ 250V ac slow blow 1500A interruption current Littelfuse p/n H2153.15
Isolation Voltage	
Group to group	100% tested at 2546V dc for 1s (265V ac max. continuous voltage)
User to system	100% tested at 2546V dc for 1s (265V ac max. continuous voltage)
RTB Screw Torque (NEMA)	7-9 inch-pounds (0.8-1Nm)
Module Keying (Backplane)	Software configurable
RTB Keying	User defined mechanical keying
Field Wiring Arm and Housing	20 Position RTB (1756-TBNH or TBSH) <sup>2</sup>
Environmental Conditions	
Operating Temperature	0 to 60°C (32 to 140°F)
Storage Temperature	-40 to 85°C (-40 to 185°F)
Relative Humidity	5 to 95% noncondensing
Conductors	
Wire Size	22-14-gauge (2mm <sup>2</sup> ) stranded <sup>2</sup> 3/64 inch (1.2mm) insulation maximum
Category	1 <sup>3, 4</sup>
Screwdriver Blade Width for RTB	5/16 inch (8mm) maximum
Agency Certification (when product or packaging is marked)	 Listed Industrial Control Equipment  Certified Process Control Equipment  Certified Class I, Division 2, Group A, B, C, D  Approved Class I, Division 2, Group A, B, C, D  Marked for all applicable directives  Marked for all applicable acts N223

<sup>1</sup> The commutating dv/dt of the output voltage (OUTPUT to L2) should not exceed 0.2V/μs for loads under 50mA. The commutating dv/dt rating of the module for loads 50-500mA (OUTPUT TO L2) is 4V/μs maximum. If the commutating dv/dt rating of the TRIAC is exceeded, the TRIAC could latch on. If the commutating dv/dt rating is exceeded in the 10-50mA range, a resistor may be added across the output and L2. The purpose of this resistor is to increase the total output current to 50mA (I=V/R). At 50mA and above, the module has a higher commutating dv/dt rating. When adding a resistor for the output to L2, be sure it is rated for the power that it will dissipate (P=(V\*\*2)/R). If the commutating dv/dt rating is exceeded in the 50-500mA range, the L1 AC waveform could be at fault. Be sure the waveform is a good sinusoid, void if any anomalies such as distorted or flattened sections.

<sup>2</sup> Maximum wire size will require extended housing - 1756-TBE.

<sup>3</sup> Use this conductor category information for planning conductor routing as described in the system level installation manual.

<sup>4</sup> Refer to publication 1770-4.1 'Industrial Automation Wiring and Grounding Guidelines'.

# 1756-OA16I

## Configurable features

The following table lists the configurable features this module supports, the default value and the page of the feature's description:

Feature	Default value	Page of description
Communications Format	Output data	6-6
Program Mode	Off	6-11
Communications Failure in Program Mode	Disabled	6-11
Fault Mode	Off	6-11

## Wiring example

Use the following example to wire your module.

- NOTES:
1. All terminals with the same name are connected together on the module. For example, L1 can be connected to either terminal marked L1-15.
  2. Do not physically connect more than two wires to a single RTB terminal. When you use the second L1-15 terminal to daisy chain to other RTBs, always connect the daisy chain as shown.
  3. The **jumper bar** part number is 97739201. Contact your local Rockwell Automation sales representative to order additional jumper bars, if necessary.
  4. If separate power sources are used, do not exceed the specified isolation voltage.

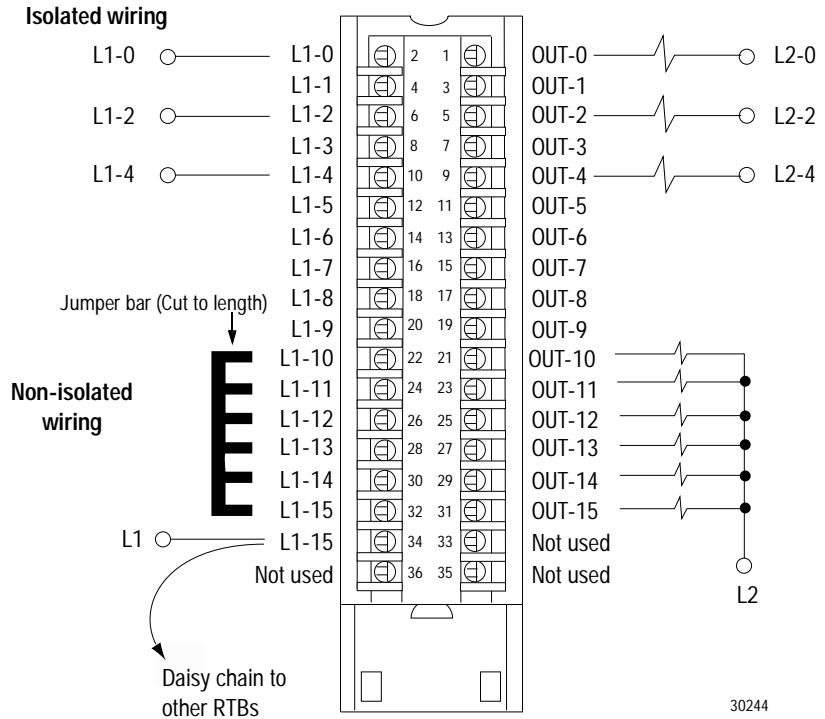

### Simplified schematic

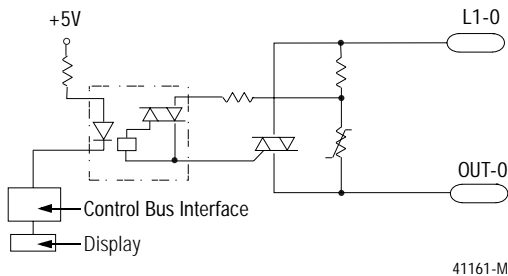



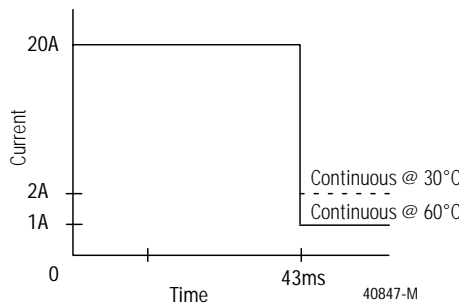

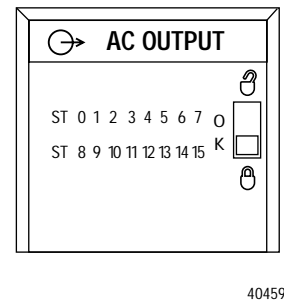

### Surge Current Chart



### LED indicator



## 1756-OA16I Specifications

Number of Outputs	16 (individually isolated)
Module Location	1756 ControlLogix Chassis
Backplane Current	300mA @ 5.1V dc & 2.5mA @ 24V dc (Total backplane power 1.60W)
Max. Power Dissipation (Module)	5.5W @ 60°C
Thermal Dissipation	18.76 BTU/hr
Output Voltage Range	74-265V ac, 47-63Hz
Output Current Rating Per Point Per Module	2A max. @ 30°C & 1A max. @ 60°C (Linear derating) 5A max. @ 30°C & 4A max. @ 60°C (Linear derating)
Surge Current per Point	20A for 43ms each, repeatable every 2s @ 60°C
Minimum Load Current	10mA per point
Maximum On-State Voltage Drop	1.5V peak @ 2A & 6V peak @ load current < 50mA
Maximum Off-State Leakage Current	3mA per point
Commutating Voltage	4V/μs for loads > 50mA 0.2V/μs for loads < 50mA <sup>1</sup>
Output Delay Time OFF to ON ON to OFF	9.3ms @ 60Hz; 11ms @ 50Hz 9.3ms @ 60Hz; 11ms @ 50Hz
Scheduled Outputs	Synchronization within 16.7 seconds maximum, reference to the CST
Configurable Fault States/ Point	Hold Last State, ON or OFF (OFF is the default)
Configurable States in Program Mode per Point	Hold Last State, ON or OFF (OFF is the default)
Maximum Inhibit Voltage	Zero crossing 60V peak
Fusing	Not protected - Fused IFM is recommended to protect outputs (See publication 1492-2.12)
Isolation Voltage Channel to channel User side to system side	100% tested at 2546V dc for 1 second (250V ac maximum continuous voltage) 100% tested at 2546V dc for 1 second (250V ac maximum continuous voltage)
RTB Screw Torque (Cage clamp)	4.4 inch-pounds (0.4Nm) maximum
Module Keying (Backplane)	Software configurable
RTB Keying	User defined mechanical keying
Field Wiring Arm and Housing	36 Position RTB (1756-TBCH or TBS6H) <sup>2</sup>
Environmental Conditions Operating Temperature Storage Temperature Relative Humidity	0 to 60°C (32 to 140°F) -40 to 85°C (-40 to 185°F) 5 to 95% noncondensing
Conductors Wire Size Category	22-14-gauge (2mm <sup>2</sup> ) stranded <sup>2</sup> 3/64 inch (1.2mm) insulation maximum 1 <sup>3, 4</sup>
Screwdriver Blade Width for RTB	1/8 inch (3.2mm) maximum
Agency Certification (when product or packaging is marked)	 Listed Industrial Control Equipment  Certified Process Control Equipment  Certified Class I, Division 2, Group A, B, C, D  Approved Class I, Division 2, Group A, B, C, D  Marked for all applicable directives  Marked for all applicable acts N223

<sup>1</sup> The commutating dv/dt of the output voltage (OUTPUT to L2) should not exceed 0.2V/μs for loads under 50mA. The commutating dv/dt rating of the module for loads 50-500mA (OUTPUT TO L2) is 4V/μs maximum. If the commutating dv/dt rating of the TRIAC is exceeded, the TRIAC could latch on. If the commutating dv/dt rating is exceeded in the 10-50mA range, a resistor may be added across the output and L2. The purpose of this resistor is to increase the total output current to 50mA (I=V/R). At 50mA and above, the module has a higher commutating dv/dt rating. When adding a resistor for the output to L2, be sure it is rated for the power that it will dissipate (P=(V\*\*2)/R). If the commutating dv/dt rating is exceeded in the 50-500mA range, the L1 AC waveform could be at fault. Be sure the waveform is a good sinusoid, void if any anomalies such as distorted or flattened sections.

<sup>2</sup> Maximum wire size will require extended housing - 1756-TBE.

<sup>3</sup> Use this conductor category information for planning conductor routing as described in the system level installation manual.

<sup>4</sup> Refer to publication 1770-4.1 "Industrial Automation Wiring and Grounding Guidelines".

# 1756-OA8

## Configurable features

The following table lists the configurable features this module supports, the default value and the page of the feature's description:

Feature	Default value	Page of description
Communications Format	Output data	6-6
Program Mode	Off	6-11
Communications Failure in Program Mode	Disabled	6-11
Fault Mode	Off	6-11





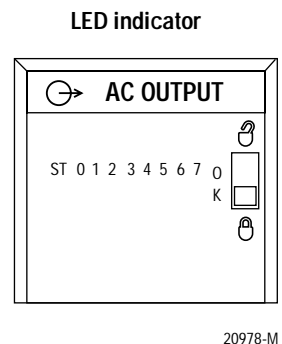
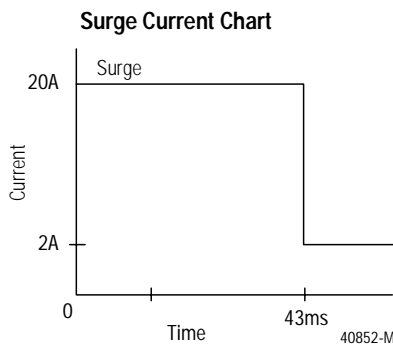
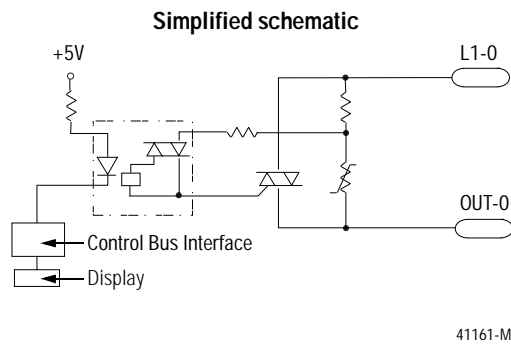
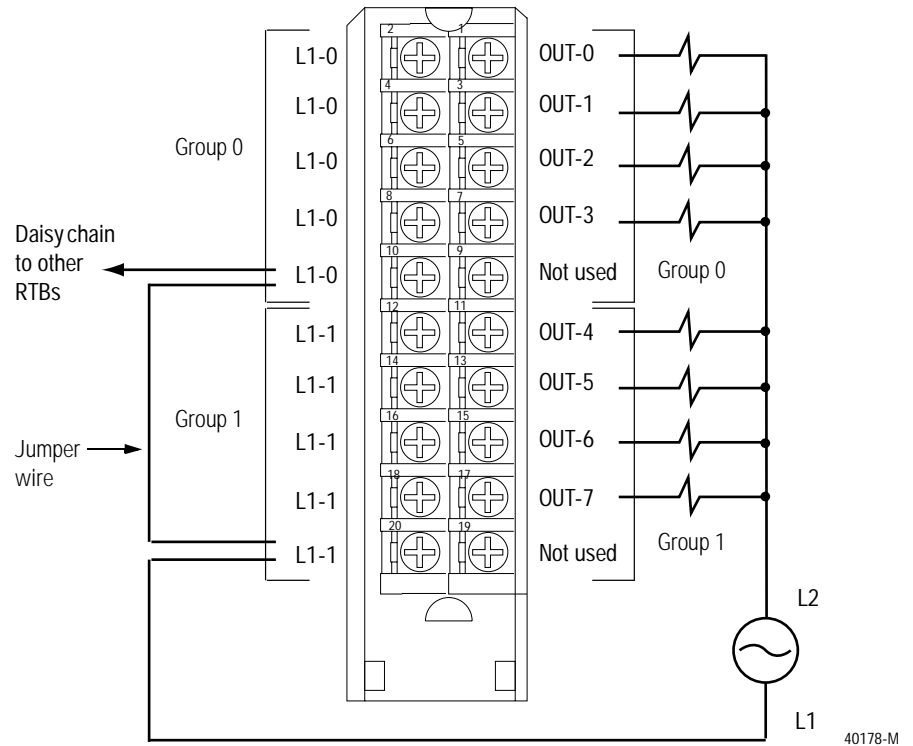

## Wiring example

Use the following example to wire your module.

- NOTES:
1. All terminals with the same name are connected together on the module. For example, L1 can be connected to any terminal marked L1-0.
  2. Do not physically connect more than two wires to a single RTB terminal. When you daisy chain from a group to another RTB, always connect the daisy chain as shown.
  3. This wiring example shows a single voltage source.
  4. If separate power sources are used, do not exceed the specified isolation voltage.



## 1756-OA8 Specifications

Number of Outputs	8 (4 points/common)
Module Location	1756 ControlLogix Chassis
Backplane Current	200mA @ 5.1V dc & 2mA @ 24V dc (Total backplane power 1.07W)
Maximum Power Dissipation	5.1W @ 60°C
Thermal Dissipation	17.39 BTU/hr
Output Voltage Range	74-265V ac, 47-63Hz
Output Current Rating Per Point Per Module	2A max. @ 60°C (Linear derating) 5A max. @ 30°C & 4A max. @ 60°C (Linear derating)
Surge Current per Point	20A for 43ms each, repeatable every 2s @ 60°C
Minimum Load Current	10mA per point
Maximum On-State Voltage Drop	1.5V peak @ 2A & 6V peak @ current<50mA
Max. Off-State Leakage Current	3mA per point
Commutating Voltage	4V/μs for loads>50mA 0.2V/μs for loads<50mA <sup>1</sup>
Output Delay Time OFF to ON ON to OFF	9.3ms @ 60Hz; 11ms @ 50Hz 9.3ms @ 60Hz; 11ms @ 50Hz
Scheduled Outputs	Synchronization within 16.7 seconds maximum, reference to the CST
Configurable Fault States/Point	Hold Last State, ON or OFF (OFF is the default)
Configurable States in Program Mode per Point	Hold Last State, ON or OFF (OFF is the default)
Maximum Inhibit Voltage	Zero crossing 60V peak
Fusing	Not protected - Fused IFM is recommended to protect outputs (See publication 1492-2.12)
Isolation Voltage Group to group User to system	100% tested at 2546V dc for 1s (265V ac max. continuous voltage) 100% tested at 2546V dc for 1s (265V ac max. continuous voltage)
RTB Screw Torque (NEMA)	7-9 inch-pounds (0.8–1Nm)
Module Keying (Backplane)	Software configurable
RTB Keying	User defined mechanical keying
Field Wiring Arm and Housing	20 Position RTB (1756-TBNH or TBSH) <sup>2</sup>
Environmental Conditions Operating Temperature Storage Temperature Relative Humidity	0 to 60°C (32 to 140°F) -40 to 85°C (-40 to 185°F) 5 to 95% noncondensing
Conductors Wire Size	22-14-gauge (2mm <sup>2</sup> ) stranded <sup>2</sup> 3/64 inch (1.2mm) insulation maximum
Category	1 <sup>3</sup> , 4
Screwdriver Blade Width for RTB	5/16 inch (8mm) maximum
Agency Certification (when product or packaging is marked)	 Listed Industrial Control Equipment  Certified Process Control Equipment  Certified Class I, Division 2, Group A, B, C, D  Approved Class I, Division 2, Group A, B, C, D  Marked for all applicable directives  Marked for all applicable acts

<sup>1</sup> The commutating dv/dt of the output voltage (OUTPUT to L2) should not exceed 0.2V/μs for loads under 50mA. The commutating dv/dt rating of the module for loads 50-500mA (OUTPUT TO L2) is 4V/μs maximum. If the commutating dv/dt rating of the TRIAC is exceeded, the TRIAC could latch on. If the commutating dv/dt rating is exceeded in the 10-50mA range, a resistor may be added across the output and L2. The purpose of this resistor is to increase the total output current to 50mA (I=V/R). At 50mA and above, the module has a higher commutating dv/dt rating. When adding a resistor for the output to L2, be sure it is rated for the power that it will dissipate (P=(V\*\*2)/R). If the commutating dv/dt rating is exceeded in the 50-500mA range, the L1 AC waveform could be at fault. Be sure the waveform is a good.

<sup>2</sup> Maximum wire size will require extended housing - 1756-TBE.

<sup>3</sup> Use this conductor category information for planning conductor routing as described in the system level installation manual.

<sup>4</sup> Refer to publication 1770-4.1 "Industrial Automation Wiring and Grounding Guidelines".

# 1756-OA8D

## Configurable features

The following table lists the configurable features this module supports, the default value and the page of the feature's description:

Feature	Default value	Page of description
Diagnostic Latch of Information	Enabled	4-11
No Load Detection	Enabled	4-21
Field Side Output Verification	Enabled	4-22
Pulse Test	Performed at user's request	4-22
Field Power Loss Detection	Enabled	4-24
Communications Format	CST timestamped fuse data - output data	6-6
Program Mode	Off	6-11
Communications Failure in Program Mode	Disabled	6-11
Fault Mode	Off	6-11

## Wiring example

Use the following example to wire your module.

- NOTES:
1. All terminals with the same name are connected together on the module. For example, L1 can be connected to any terminal marked L1-0.
  2. Do not physically connect more than two wires to a single RTB terminal. When you daisy chain from a group to another RTB, always connect the daisy chain as shown.
  3. This wiring example shows a single voltage source.
  4. If separate power sources are used, do not exceed the specified isolation voltage.

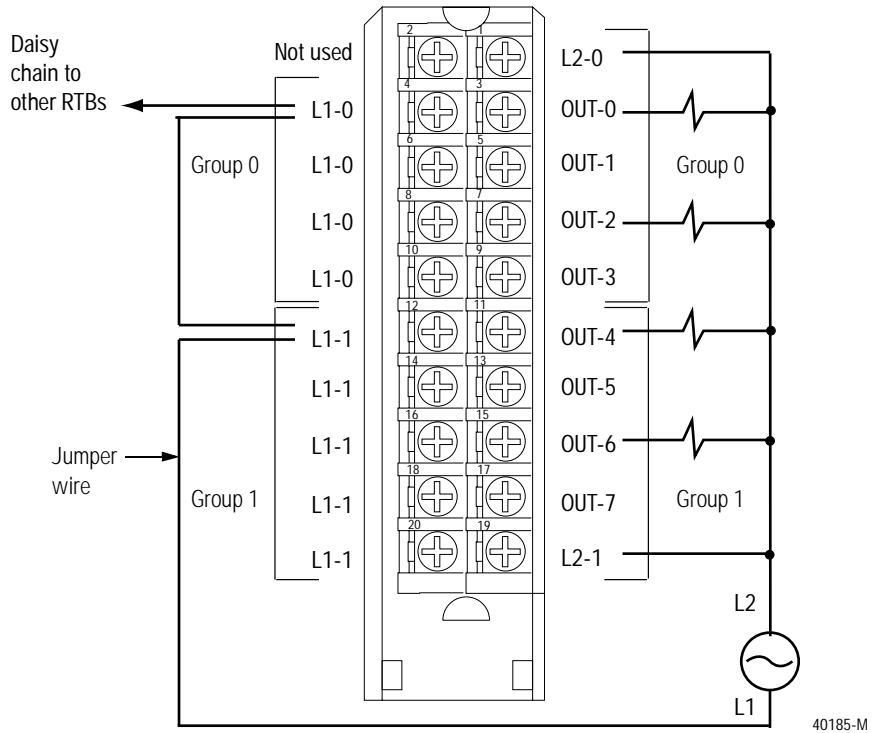

### Simplified schematic

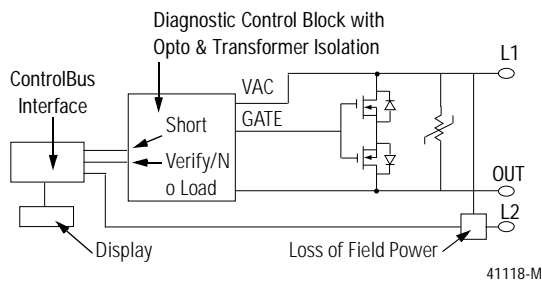



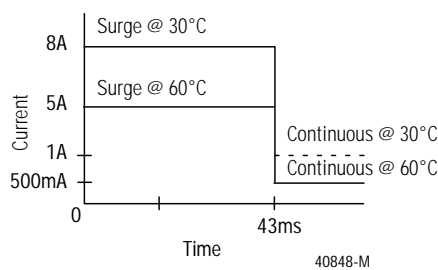

### Surge Current Chart

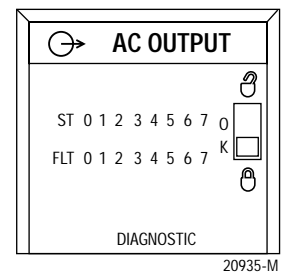

### LED indicator



## 1756-OA8D Specifications

Number of Outputs	8 (4 points/common)
Module Location	1756 ControlLogix Chassis
Backplane Current	175mA @ 5.1V dc & 250mA @ 24V dc (Total backplane power 6.89W)
Maximum Power Dissipation (Module)	5.3W @ 60°C
Thermal Dissipation	18 BTU/hr
Output Voltage Range	74-132V ac, 47-63Hz
Output Current Rating Per Point Per Module	1A max @ 30°C & 0.5A max. @ 60°C (Linear derating) 8A max @ 30°C & 4A max. @ 60°C (Linear derating)
Surge Current per Point	8A for 43ms each, repeatable every 2s @ 30°C 5A for 43ms each, repeatable every 1s @ 60°C
Minimum Load Current	10mA per point
Maximum On-State Voltage Drop	2.5V peak @ 0.5A & 3V peak @ 1A
Maximum Off-State Leakage Current	3mA per point
Output Delay Time OFF to ON ON to OFF	9.3ms @ 60Hz; 11ms @ 50Hz 9.3ms @ 60Hz; 11ms @ 50Hz
Scheduled Outputs	Synchronization within 16.7s maximum, reference to the CST
Configurable Fault States/Point	Hold Last State, ON or OFF (OFF is the default)
Configurable States in Program Mode per Point	Hold Last State, ON or OFF (OFF is the default)
Diagnostic Functions Short Trip NoLoad Output Verification Pulse Test  Field Power Loss (Zero Cross) Time stamp of diagnostics	12A for 500µs minimum Off state detection only On state detection only User selectable maximum width & user selectable maximum time delay from zero cross Detects at 25V peak minimum (Firmware phase locked loop) +/- 1ms
Maximum Inhibit Voltage	Zero crossing 25V peak
Fusing	Electronically fused per point
Isolation Voltage Group to group User to system	100% tested at 2546V dc for 1s (250V ac max. continuous voltage) 100% tested at 2546V dc for 1s (250V ac max. continuous voltage)
Module Keying (Backplane)	Software configurable
RTB Screw Torque (NEMA)	7-9 inch-pounds (0.8-1Nm)
RTB Keying	User defined mechanical keying
RTB and Housing	20 Position RTB (1756-TBNH or TBSH)
Environmental Conditions Operating Temperature Storage Temperature Relative Humidity	0 to 60°C (32 to 140°F) -40 to 85°C (-40 to 185°F) 5 to 95% noncondensing
Conductors Wire Size  Category	22-14-gauge (2mm <sup>2</sup> ) stranded <sup>1</sup> 3/64 inch (1.2mm) insulation maximum <sup>1,2,3</sup>
Screwdriver Width for RTB	5/16 inch (8mm) maximum
Agency Certification (when product or packaging is marked)	 Listed Industrial Control Equipment  Certified Process Control Equipment Certified Class I, Division 2, Group A, B, C, D  Approved Class I, Division 2, Group A, B, C, D  Marked for all applicable directives  Marked for all applicable acts N223

<sup>1</sup> Maximum wire size will require extended housing - 1756-TBE.

<sup>2</sup> Use this conductor category information for planning conductor routing as described in the system level installation manual.

<sup>3</sup> Refer to publication 1770-4.1 "Industrial Automation Wiring and Grounding Guidelines".

# 1756-OA8E

## Configurable features

The following table lists the configurable features this module supports, the default value and the page of the feature's description:

Feature	Default value	Page of description
Field Power Loss Detection	Enabled	3-17
Diagnostic Latch of Information	Enabled	3-17
Communications Format	CST timestamped fuse data - output data	6-6
Program Mode	Off	6-11
Communications Failure in Program Mode	Disabled	6-11
Fault Mode	Off	6-11

## Wiring example

Use the following example to wire your module.

- NOTES: 1. All terminals with the same name are connected together on the module. For example, L1 can be connected to any terminal marked L1-0.
2. Do not physically connect more than two wires to a single RTB terminal. When you daisy chain from a group to another RTB, always connect the daisy chain as shown.
3. This wiring example shows a single voltage source.
4. If separate power sources are used, do not exceed the specified isolation voltage.

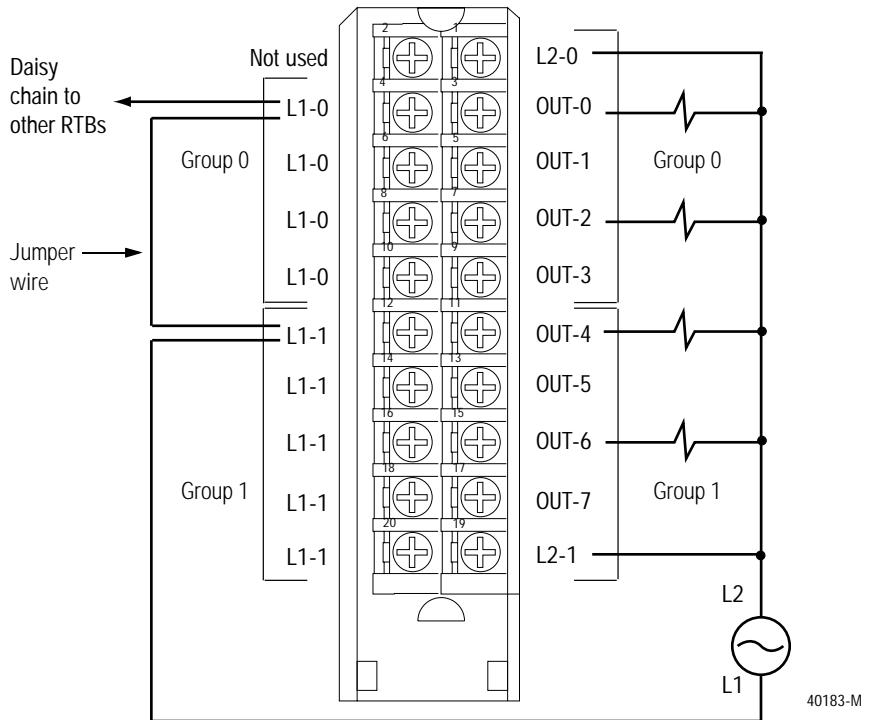

### Simplified schematic

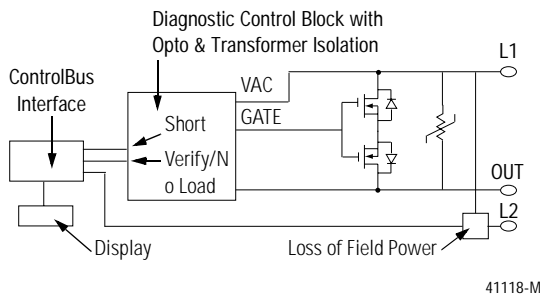



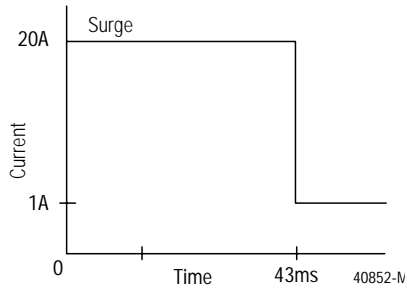

### Surge Current Chart

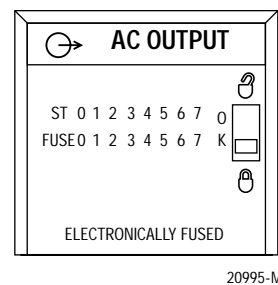

### LED indicator



## 1756-OA8E Specifications

Number of Outputs	8 (4 points/common)
Module Location	1756 ControlLogix Chassis
Backplane Current	200mA @ 5.1V dc & 250mA @ 24V dc (Total backplane power 7.02W)
Max. Power Dissipation (Module)	5.5W @ 60°C
Thermal Dissipation	18.76 BTU/hr
Output Voltage Range	74-132V ac, 47-63Hz
Output Current Rating Per Point Per Group Per Module	2A max. @ 60°C 4A max. @ 30°C & 2A max @ 60°C (Linear derating) 8A max. @ 30°C & 4A max @ 60°C (Linear derating)
Surge Current per Point	20A for 43ms each, repeatable every 2s @ 60°C
Minimum Load Current	10mA per point
Maximum On-State Voltage Drop	4V peak @ 2A
Max. Off-State Leakage Current	3mA per point
Output Delay Time OFF to ON ON to OFF	9.3ms @ 60Hz; 11ms @ 50Hz 9.3ms @ 60Hz; 11ms @ 50Hz
Diagnostic Functions Short Trip Field Power Loss (Zero Cross) Time stamp of Diagnostics	>20A for 100ms minimum Detects at 25V peak minimum (Firmware phase locked loop) +/- 1ms
Configurable Fault States/Point	Hold Last State, ON or OFF (OFF is the default)
Configurable States in Program Mode/Point	Hold Last State, ON or OFF (OFF is the default)
Scheduled Outputs	Synchronization within 16.7s maximum, reference to CST
Maximum Inhibit Voltage	Zero crossing 25V peak
Fusing	Electronically fused per point
Isolation Voltage Group to group User to system	100% tested at 2546V dc for 1s (250V ac max. continuous voltage) 100% tested at 2546V dc for 1s (250V ac max. continuous voltage)
RTB Screw Torque (NEMA)	7-9 inch-pounds (0.8-1Nm)
Module Keying (Backplane)	Software configurable
RTB Keying	User defined mechanical keying
RTB and Housing	20 Position RTB (1756-TBNH or TBSH) <sup>1</sup>
Environmental Conditions Operating Temperature Storage Temperature Relative Humidity	0 to 60°C (32 to 140°F) -40 to 85°C (-40 to 185°F) 5 to 95% noncondensing
Conductors Wire Size Category	22-14-gauge (2mm <sup>2</sup> ) stranded <sup>1</sup> 3/64 inch (1.2mm) insulation maximum <sup>1,2,3</sup>
Screwdriver Blade Width for RTB	5/16 inch (8mm) maximum
Agency Certification (when product or packaging is marked)	 Listed Industrial Control Equipment  Certified Process Control Equipment Certified Class I, Division 2, Group A, B, C, D  Approved Class I, Division 2, Group A, B, C, D  Marked for all applicable directives  Marked for all applicable acts N223

<sup>1</sup> Maximum wire size will require extended housing - 1756-TBE.

<sup>2</sup> Use this conductor category information for planning conductor routing as described in the system level installation manual.

<sup>3</sup> Refer to publication 1770-4.1 "Industrial Automation Wiring and Grounding Guidelines".

# 1756-OB16D

## Configurable features

The following table lists the configurable features this module supports, the default value and the page of the feature's description:

Feature	Default value	Page of description
Diagnostic Latch of Information	Enabled	4-11
No Load Detection	Enabled	4-21
Field Side Output Verification	Enabled	4-22
Pulse Test	Performed at user's request	4-22
Communications Format	CST timestamped fuse data - output data	6-6
Program Mode	Off	6-11
Communications Failure in Program Mode	Disabled	6-11
Fault Mode	Off	6-11



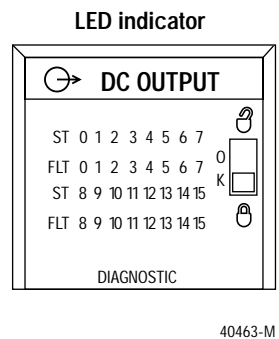
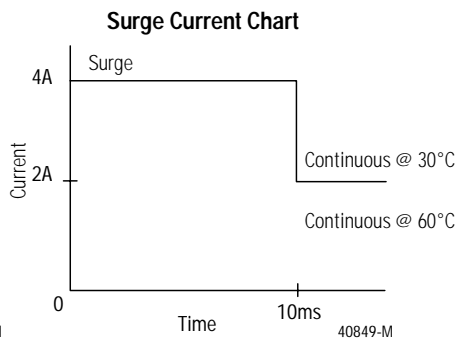
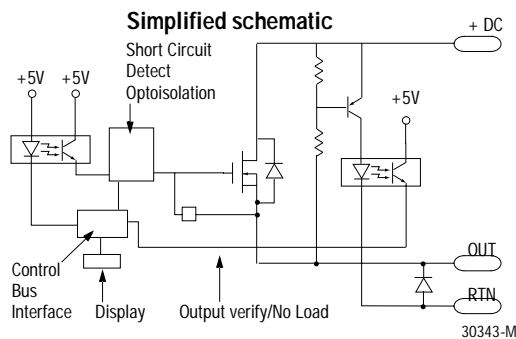
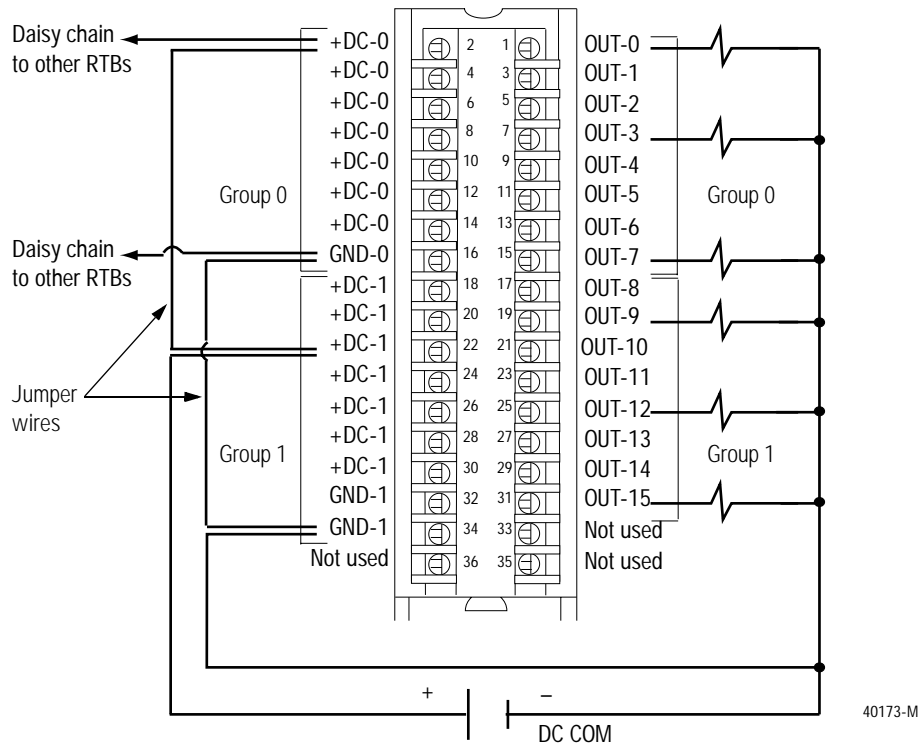

## Wiring example

Use the following example to wire your module.

- NOTES: 1. All terminals with the same name are connected together on the module. For example, DC COM can be connected to either terminal marked GND-1.
2. Do not physically connect more than two wires to a single RTB terminal. When you daisy chain from a group to another RTB, always connect the daisy chain as shown.
3. This wiring example shows a single voltage source.
4. If separate power sources are used, do not exceed the specified isolation voltage.



## 1756-OB16D Specifications

Number of Outputs	16 (8 points/common)
Module Location	1756 ControlLogix Chassis
Backplane Current	250mA @ 5.1V dc & 140mA @ 24V dc (Total backplane power 4.64W)
Max. Power Dissipation (Module)	3.3W @ 60°C
Thermal Dissipation	11.25 BTU/hr
Output Voltage Range	19.2-30V dc
Output Current Rating Per Point Per Module	2A max. @ 30°C & 1A max. @ 60°C (Linear derating) 8A max. @ 30°C & 4A max. @ 60°C (Linear derating)
Surge Current per Point	4A for 10ms each, repeatable every 1s
Minimum Load Current	3mA per point
Maximum On-State Voltage Drop	1.2V dc @ 2A
Max. Off-State Leakage Current	1mA per point
Output Delay Time OFF to ON ON to OFF	1ms maximum 5ms maximum
Diagnostic Functions: Short trip  No load Output verification Pulse test Time stamp of diagnostics	8A 180ms minimum 10A 120ms minimum OFF STATE detection only ON STATE detection only User selectable maximum pulse width +/- 1ms
Configurable Fault States/Point	Hold Last State, ON or OFF (OFF is the default)
Configurable States in Program Mode/Point	Hold Last State, ON or OFF (OFF is the default)
Scheduled Outputs	Synchronization within 16.7s maximum, reference to the CST
Fusing	Electronically fused per point
Reverse Polarity Protection	None - If module is wired incorrectly, outputs may be damaged.
Isolation Voltage Group to group User to system	100% tested at 2546V dc for 1s (250V ac max. continuous voltage) 100% tested at 2546V dc for 1s (250V ac max. continuous voltage)
RTB Screw Torque (Cage clamp)	4.4 inch-pounds (0.4Nm) maximum
Module Keying (Backplane)	Software configurable
RTB Keying	User defined mechanical keying
RTB and Housing	36 Position RTB (1756-TBCH or TBS6H) <sup>1</sup>
Environmental Conditions Operating Temperature Storage Temperature Relative Humidity	0 to 60°C (32 to 140°F) -40 to 85°C (-40 to 185°F) 5 to 95% noncondensing
Conductors Wire Size  Category	22-14-gauge (2mm <sup>2</sup> ) stranded <sup>1</sup> 3/64 inch (1.2mm) insulation maximum <sub>1,2,3</sub>
Screwdriver Blade Width for RTB	1/8 inch (3.2mm) maximum
Agency Certification (when product or packaging is marked)	 Listed Industrial Control Equipment  Certified Process Control Equipment Certified Class I, Division 2, Group A, B, C, D  Approved Class I, Division 2, Group A, B, C, D  Marked for all applicable directives  Marked for all applicable acts N223

<sup>1</sup> Maximum wire size will require extended housing - 1756-TBE.

<sup>2</sup> Use this conductor category information for planning conductor routing as described in the system level installation manual.

<sup>3</sup> Refer to publication 1770-4.1 'Industrial Automation Wiring and Grounding Guidelines'.

# 1756-OB16E

## Configurable features

The following table lists the configurable features this module supports, the default value and the page of the feature's description:

Feature	Default value	Page of description
Communications Format	CST timestamped fuse data - output data	6-6
Program Mode	Off	6-11
Communications Failure in Program Mode	Disabled	6-11
Fault Mode	Off	6-11

## Wiring example

Use the following example to wire your module.



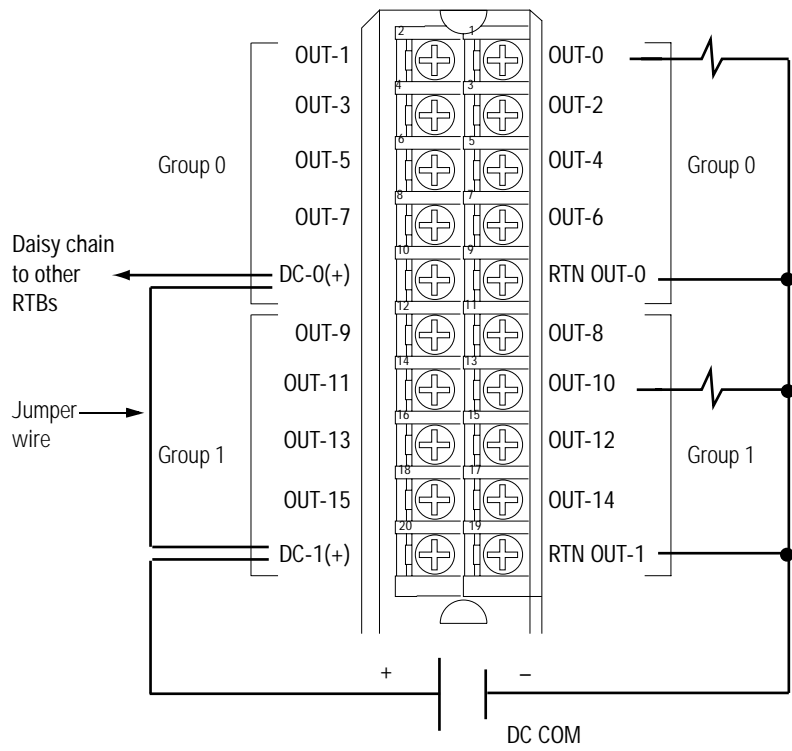

- NOTES: **1.** Do not physically connect more than two wires to a single RTB terminal. When you daisy chain from a group to another RTB, always connect the daisy chain as shown.
- 2.** This wiring example shows a single voltage source.
- 3.** If separate power sources are used, do not exceed the specified isolation voltage.

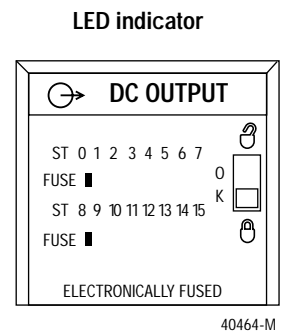
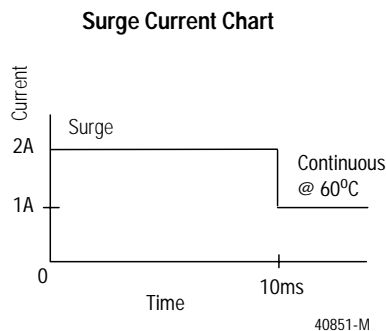
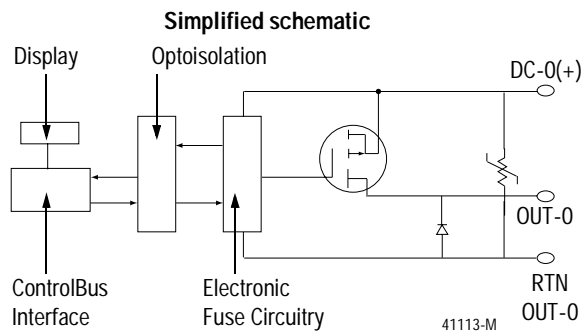

40174-M



## 1756-OB16E Specifications

Number of Outputs	16 (8 points/common)
Module Location	1756 ControlLogix Chassis
Backplane Current	250mA @ 5.1V dc & 2mA @ 24V dc (Total backplane power 1.32W)
Maximum Power Dissipation (Module)	4.1W @ 60°C
Thermal Dissipation	13.98 BTU/hr
Output Voltage Range	10-31.2V dc
Output Current Rating Per Point Per Module	1A maximum @ 60°C 8A maximum @ 60°C
Surge Current per Point	2A for 10ms each, repeatable every 2s @ 60°C
Minimum Load Current	3mA per output
Maximum On-State Voltage Drop	400mV dc @ 1A
Maximum Off-State Leakage Current	1mA per point
Output Delay Time OFF to ON ON to OFF	1ms maximum 1ms maximum
Diagnostic Functions: Short Trip  Time stamp of diagnostics	1.8A @ 24V dc (Output ON, then short) 4.1A @ 24V dc for 18ms (Output ON into short) +/- 1ms
Scheduled Outputs	Synchronization within 16.7 seconds maximum, reference to the CST
Configurable Fault States per Point	Hold Last State, ON or OFF (OFF is the default)
Configurable States in Program Mode per Point	Hold Last State, ON or OFF (OFF is the default)
Fusing	Electronically fused per group
Reverse Polarity Protection	None - If module is wired incorrectly, outputs may be damaged.
Isolation Voltage Group to group User to system	100% tested at 2546V dc for 1s (250V ac max. continuous voltage) 100% tested at 2546V dc for 1s (250V ac max. continuous voltage)
RTB Screw Torque (NEMA)	7-9 inch-pounds (0.8-1Nm)
Module Keying (Backplane)	Software configurable
RTB Keying	User defined mechanical keying
Field Wiring Arm and Housing	20 Position RTB (1756-TBNH or TBSH) <sup>1</sup>
Environmental Conditions Operating Temperature Storage Temperature Relative Humidity	0 to 60°C (32 to 140°F) -40 to 85°C (-40 to 185°F) 5 to 95% noncondensing
Conductors      Wire Size  Category	22-14-gauge (2mm <sup>2</sup> ) stranded <sup>1</sup> 3/64 inch (1.2mm) insulation maximum <sup>1,2,3</sup>
Screwdriver Blade Width for RTB	5/16 inch (8mm) maximum
Agency Certification (when product or packaging is marked)	 Listed Industrial Control Equipment  Certified Process Control Equipment Certified Class I, Division 2, Group A, B, C, D  Approved Class I, Division 2, Group A, B, C, D  Marked for all applicable directives  Marked for all applicable acts N223

<sup>1</sup> Maximum wire size will require extended housing - 1756-TBE.

<sup>2</sup> Use this conductor category information for planning conductor routing as described in the system level installation manual.

<sup>3</sup> Refer to publication 1770-4.1 "Industrial Automation Wiring and Grounding Guidelines".

# 1756-OB16I

## Configurable features

The following table lists the configurable features this module supports, the default value and the page of the feature's description:

Feature	Default value	Page of description
Communications Format	Output data	6-6
Program Mode	Off	6-11
Communications Failure in Program Mode	Disabled	6-11
Fault Mode	Off	6-11

## Wiring example

Use the following example to wire your module.

- NOTES:
1. All terminals with the same name are connected together on the module. For example, DC(+) can be connected to either terminal marked DC-15.
  2. Do not physically connect more than two wires to a single RTB terminal. When you use the second DC-15(+) terminal to daisy chain to other RTBs, always connect the daisy chain as shown.
  3. Outputs can be wired in a sink or source configuration as shown above.
  4. The **jumper bar** part number is 97739201. Contact your local Rockwell Automation sales representative to order additional jumper bars, if necessary.
  5. If separate power sources are used, do not exceed the specified isolation voltage.

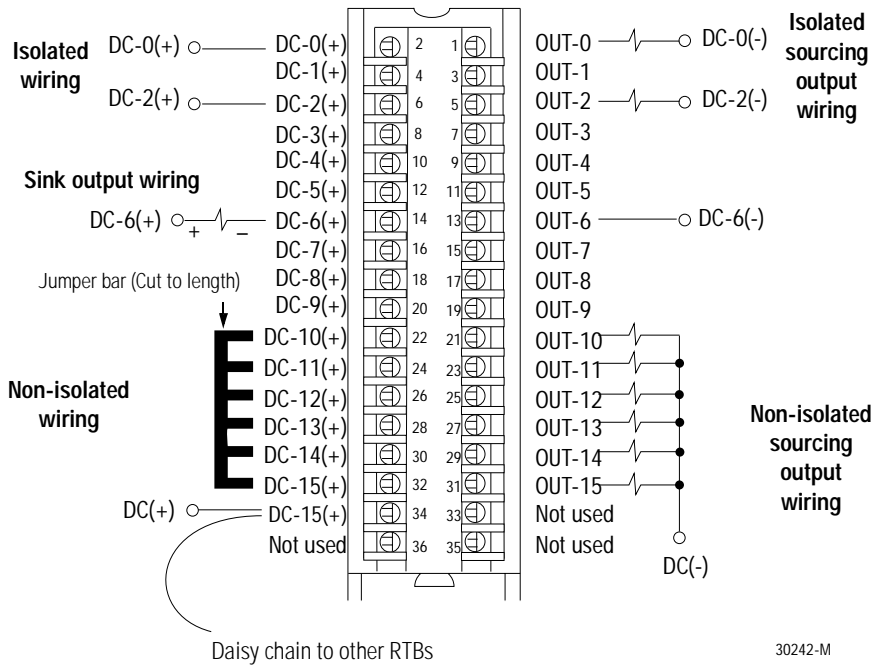

30242-M

Simplified schematic

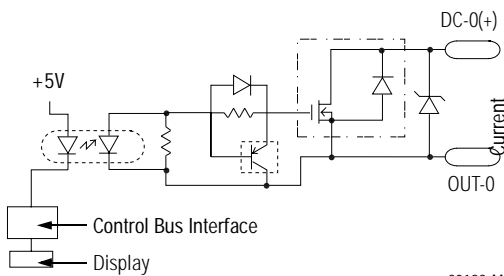

30182-M

Surge Current Chart

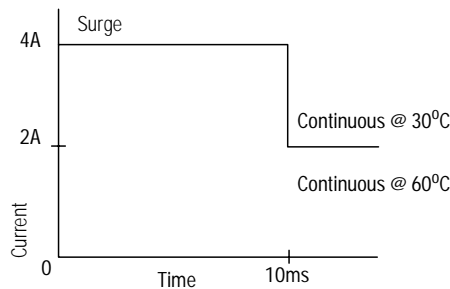





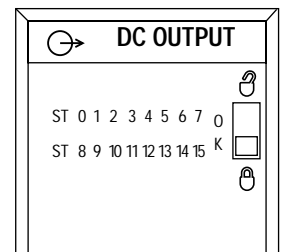

40849-M

LED indicator



40457-M

## 1756-OB16I Specifications

Number of Outputs	16 (individually isolated)
Module Location	1756 ControlLogix Chassis
Backplane Current	350mA @ 5.1V dc & 2.5mA @ 24V dc (1.8W Total backplane power)
Max. Power Dissipation (Module)	3.6W @ 60°C
Thermal Dissipation	12.28 BTU/hr
Output Voltage Range	10-30V dc
Output Current Rating Per Point Per Module	2A max. @ 30°C & 1A max. @ 60°C (Linear derating) 8A max. @ 30°C & 4A max. @ 60°C (Linear derating)
Surge Current/Point	4A for 10ms each, repeatable every 2s
Minimum Load Current	1mA per point
Max. On-State Voltage Drop	1.2V dc @ 2A
Max. Off-State Leakage Current	0.5mA per point
Output Delay Time OFF to ON ON to OFF	1ms max. 2ms max.
Scheduled Outputs	Synchronization within 16.7s max., reference to the CST
Configurable Fault States/ Point	Hold Last State, ON or OFF (OFF is the default)
Configurable States in Program Mode/Point	Hold Last State, ON or OFF (OFF is the default)
Fusing	Not protected - Fused IFM is recommended to protect outputs (See publication 1492-2.12)
Reverse Polarity Protection	None (If module is wired incorrectly, outputs may be damaged.)
Isolation Voltage Channel to channel User to system	100% tested at 2546V dc for 1s (250V ac max. continuous voltage) 100% tested at 2546V dc for 1s (250V ac max. continuous voltage)
Module Keying (Backplane)	Software configurable
RTB Screw Torque (Cage clamp)	4.4 inch-pounds (0.4Nm) max.
RTB Keying	User defined mechanical keying
RTB and Housing	36 Position RTB (1756-TBCH or TBS6H) <sup>1</sup>
Screwdriver Blade Width for RTB	1/8 inch (3.2mm) max.
Environmental Conditions Operating Temperature Storage Temperature Relative Humidity	0 to 60°C (32 to 140°F) -40 to 85°C (-40 to 185°F) 5 to 95% noncondensing
Conductors      Wire Size  Category	22–14-gauge (2mm <sup>2</sup> ) stranded <sup>1</sup> 3/64 inch (1.2mm) insulation max. 1 <sup>2, 3</sup>
Agency Certification (when product or packaging is marked)	 Listed Industrial Control Equipment  Certified Process Control Equipment  Certified Class I, Division 2, Group A, B, C, D  Approved Class I, Division 2, Group A, B, C, D  Marked for all applicable directives  Marked for all applicable acts N223

<sup>1</sup> Maximum wire size will require extended housing - 1756-TBE.

<sup>2</sup> Use this conductor category information for planning conductor routing as described in the system level installation manual.

<sup>3</sup> Refer to publication 1770-4.1 'Industrial Automation Wiring and Grounding Guidelines'.

# 1756-OB32

## Configurable features

The following table lists the configurable features this module supports, the default value and the page of the feature's description:

Feature	Default value	Page of description
Communications Format	Output data	6-6
Program Mode	Off	6-11
Communications Failure in Program Mode	Disabled	6-11
Fault Mode	Off	6-11



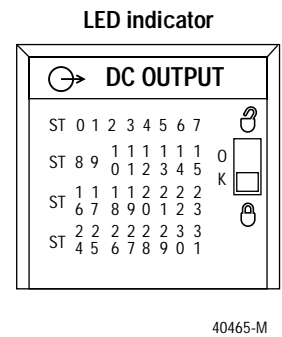
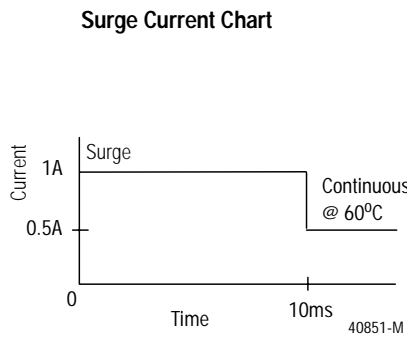
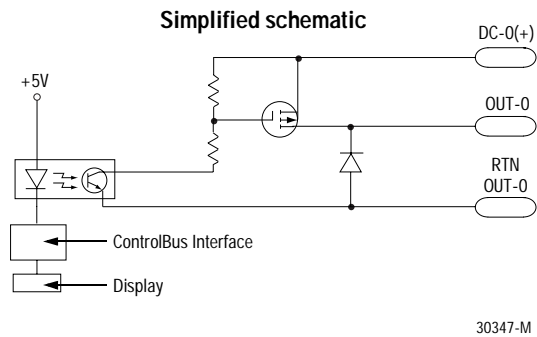
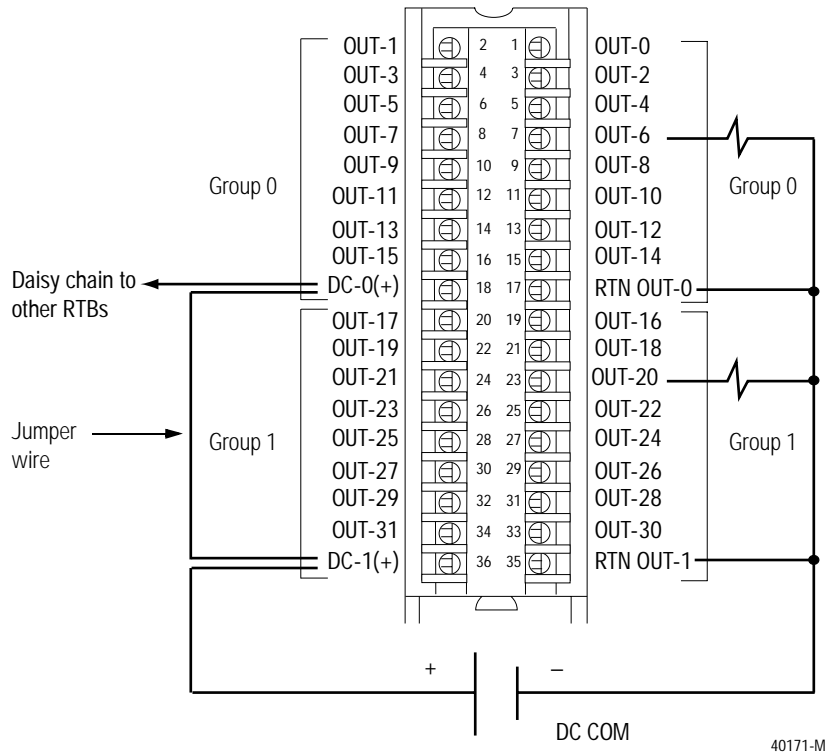

## Wiring example

Use the following example to wire your module.

- NOTES: **1.** Do not physically connect more than two wires to a single RTB terminal. When you daisy chain from a group to another RTB, always connect the daisy chain as shown.
- 2.** This wiring example uses a single voltage source.
- 3.** If separate power sources are used, do not exceed the specified isolation voltage.



## 1756-OB32 Specifications

Number of Outputs	32 (16 points/common)
Module Location	1756 ControlLogix Chassis
Backplane Current	300mA @ 5.1V dc & 2mA @ 24V dc (Total backplane power 1.58W)
Maximum Power Dissipation	4.8W @ 60°C
Thermal Dissipation	16.37 BTU/hr
Output Voltage Range	10-31.2V dc @ 50°C (Linear derating) 10-28V dc @ 60°C
Output Current Rating Per Point	0.5A maximum @ 50°C (Linear derating) 0.35A maximum @ 60°C
Per Module	16A maximum @ 50°C (Linear derating) 10A maximum @ 60°C
Surge Current per Point	1A for 10ms each, repeatable every 2s @ 60°C
Minimum Load Current	3mA per point
Maximum On-State Voltage Drop	200mV dc @ 0.5A
Maximum Off-State Leakage Current	0.5mA per point
Output Delay Time OFF to ON ON to OFF	1ms maximum 1ms maximum
Scheduled Outputs	Synchronization within 16.7s maximum, reference to the CST
Configurable Fault States/Point	Hold Last State, ON or OFF (OFF is the default)
Configurable States in Program Mode per Point	Hold Last State, ON or OFF (OFF is the default)
Fusing	Not protected - Fused IFM is recommended to protect outputs (See publication 1492-2.12)
Reverse Polarity Protection	None - If module is wired incorrectly, outputs may be damaged.
Isolation Voltage Group to group User to system	100% tested at 2546V dc for 1s (250V ac max. continuous voltage) 100% tested at 2546V dc for 1s (250V ac max. continuous voltage)
RTB Screw Torque (Cage clamp)	4.4 inch-pounds (0.4Nm) maximum
Module Keying (Backplane)	Software configurable
RTB Keying	User defined mechanical keying
Field Wiring Arm and Housing	36 Position RTB (1756-TBCH or TBS6H) <sup>1</sup>
Environmental Conditions Operating Temperature Storage Temperature Relative Humidity	0 to 60°C (32 to 140°F) -40 to 85°C (-40 to 185°F) 5 to 95% noncondensing
Conductors Wire Size	22-14 gauge (2mm <sup>2</sup> ) stranded <sup>1</sup> 3/64 inch (1.2mm) insulation maximum
Category	1 <sup>2, 3</sup>
Screwdriver Blade Width for RTB	1/8 inch (3.2mm) maximum
Agency Certification (when product or packaging is marked)	 Listed Industrial Control Equipment  Certified Process Control Equipment Certified Class I, Division 2, Group A, B, C, D  Approved Class I, Division 2, Group A, B, C, D  Marked for all applicable directives  Marked for all applicable acts N223

<sup>1</sup> Maximum wire size will require extended housing - 1756-TBE.

<sup>2</sup> Use this conductor category information for planning conductor routing as described in the system level installation manual.

<sup>3</sup> Refer to publication 1770-4.1 "Industrial Automation Wiring and Grounding Guidelines".

# 1756-OB8

## Configurable features

The following table lists the configurable features this module supports, the default value and the page of the feature's description:

Feature	Default value	Page of description
Communications Format	Output data	6-6
Program Mode	Off	6-11
Communications Failure in Program Mode	Disabled	6-11
Fault Mode	Off	6-11

## Wiring example

Use the following example to wire your module.

- NOTES: **1.** All terminals with the same name are connected on the module. For example, DC COM can be connected to either terminal marked RTN OUT-1.
- 2.** Do not physically connect more than two wires to a single RTB terminal. When you daisy chain from a group to another RTB, always connect the daisy chain as shown.
- 3.** This wiring example shows a single voltage source.
- 4.** If separate power sources are used, do not exceed the specified isolation voltage.

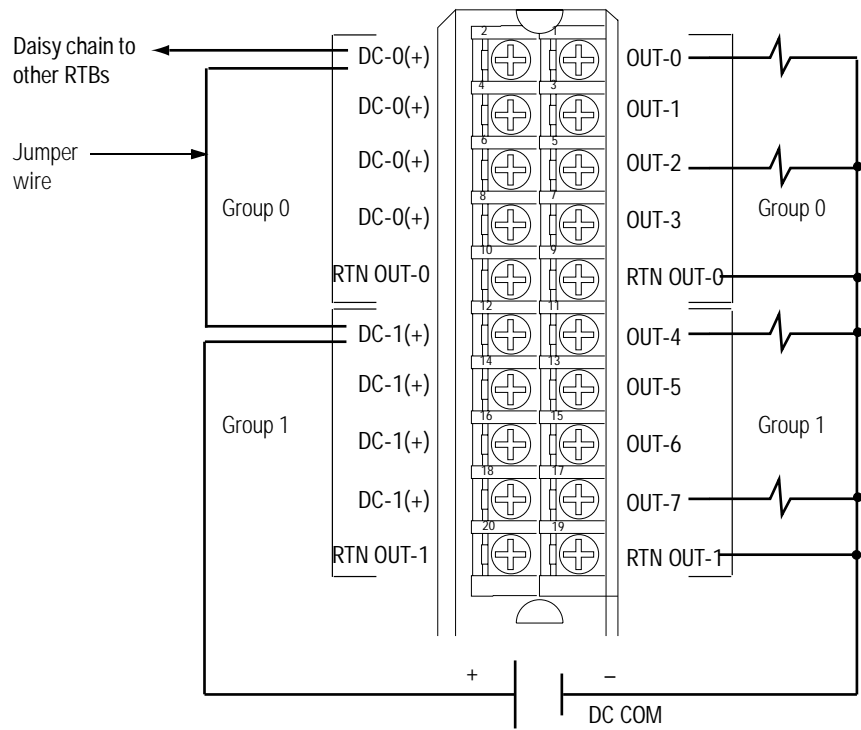

40181-M

Simplified schematic

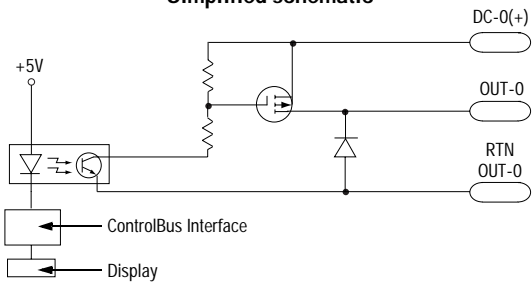

30347-M

Surge Current Chart

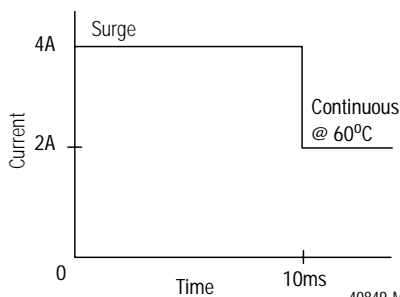



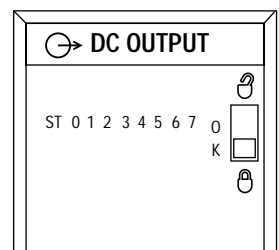

40849-M

LED indicator



40466-M

## 1756-OB8 Specifications

Number of Outputs	8 (4 points/common)
Module Location	1756 ControlLogix Chassis
Backplane Current	165mA @ 5.1V dc & 2mA @ 24V dc (Total backplane power 0.89W)
Maximum Power Dissipation (Module)	2.5W @ 60°C
Thermal Dissipation	8.53 BTU/hr
Output Voltage Range	10-30V dc
Output Current Rating Per Point Per Module	2A maximum @ 60°C 8A maximum @ 60°C
Surge Current per Point	4A for 10ms each, repeatable every 1s @ 60°C
Minimum Load Current	2mA per point
Maximum On-State Voltage Drop	2V dc @ 2A
Maximum Off-State Leakage Current	1mA per point
Output Delay Time OFF to ON ON to OFF	1ms maximum 2ms maximum
Scheduled Outputs	Synchronization within 16.7s maximum, reference to the CST
Configurable Fault States/Point	Hold Last State, ON or OFF (OFF is the default)
Configurable States in Program Mode/Point	Hold Last State, ON or OFF (OFF is the default)
Fusing	Not protected - Fused IFM is recommended to protect outputs (See publication 1492-2.12)
Reverse Polarity Protection	None - If module is wired incorrectly, outputs may be damaged.
Isolation Voltage Group to group User to system	100% tested at 2546V dc for 1s (250V ac max. continuous voltage) 100% tested at 2546V dc for 1s (250V ac max. continuous voltage)
Module Keying (Backplane)	Software configurable
RTB Screw Torque (NEMA)	7-9 inch-pounds (0.8-1Nm)
RTB Keying	User defined mechanical keying
RTB and Housing	20 Position RTB (1756-TBNH or TBSH) <sup>1</sup>
Environmental Conditions Operating Temperature Storage Temperature Relative Humidity	0 to 60°C (32 to 140°F) -40 to 85°C (-40 to 185°F) 5 to 95% noncondensing
Conductors Wire Size Category	22-14-gauge (2mm <sup>2</sup> ) stranded <sup>1</sup> 3/64 inch (1.2mm) insulation maximum <sup>1, 2, 3</sup>
Screwdriver Blade Width for RTB	5/16 inch (8mm) maximum
Agency Certification (when product or packaging is marked)	 Listed Industrial Control Equipment  Certified Process Control Equipment Certified Class I, Division 2, Group A, B, C, D  Approved Class I, Division 2, Group A, B, C, D  Marked for all applicable directives  Marked for all applicable acts N223

<sup>1</sup> Maximum wire size will require extended housing - 1756-TBE.

<sup>2</sup> Use this conductor category information for planning conductor routing as described in the system level installation manual.

<sup>3</sup> Refer to publication 1770-4.1 "Industrial Automation Wiring and Grounding Guidelines".

# 1756-OB8EI

## Configurable features

The following table lists the configurable features this module supports, the default value and the page of the feature's description:

Feature	Default value	Page of description
Communications Format	CST timestamped fuse data - output data	6-6
Program Mode	Off	6-11
Communications Failure in Program Mode	Disabled	6-11
Fault Mode	Off	6-11

## Wiring example

Use the following example to wire your module.

- NOTES:
1. All terminals with the same name are connected together on the module. For example, the load can be connected to either terminal marked OUT-0.
  2. Do not physically connect more than two wires to a single RTB terminal. When you daisy chain to other RTBs, always connect the daisy chain as shown.
  3. If separate power sources are used, do not exceed the specified isolation voltage.

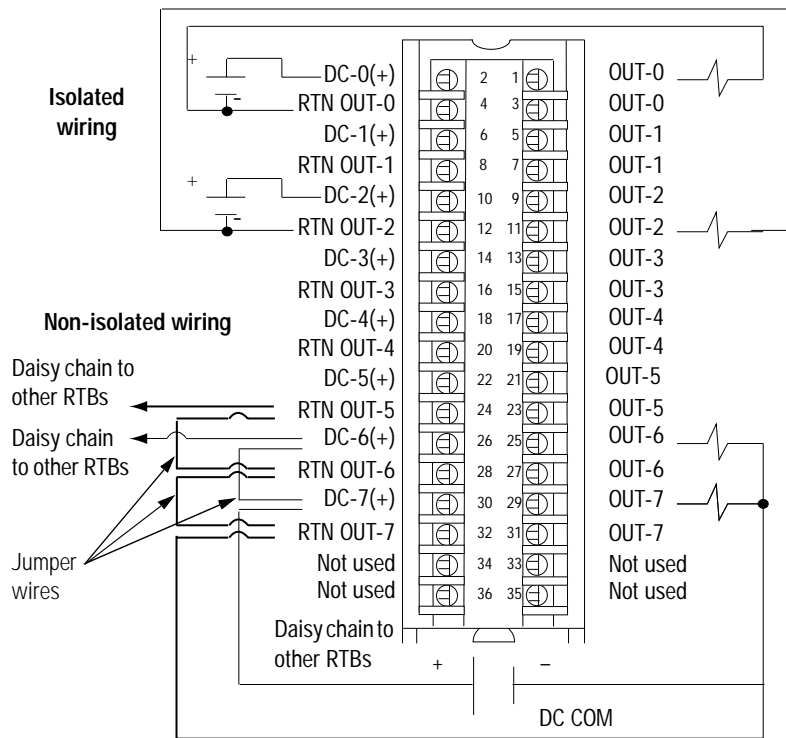

40169-M

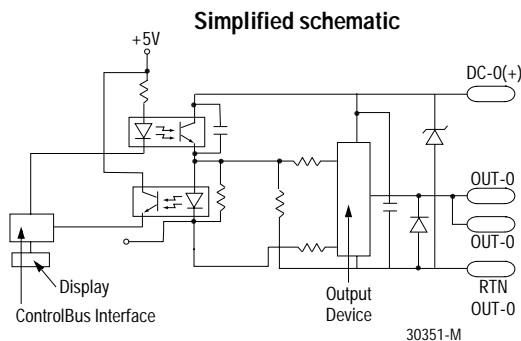

30351-M

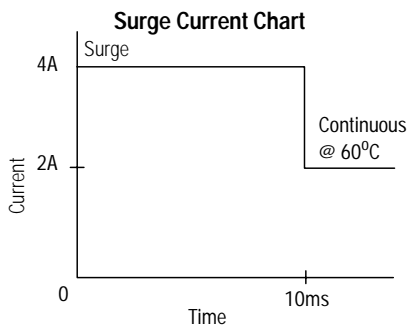



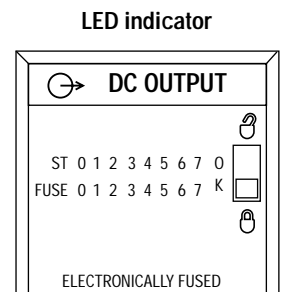

40849-M



40467-M

## 1756-OB8EI Specifications

Number of Outputs	8 (individually isolated)
Module Location	1756 ControlLogix Chassis
Backplane Current	250mA @ 5.1V dc & 2mA @ 24V dc (Total backplane power 1.30W)
Max. Power Dissipation (Module)	4.7W @ 60°C
Thermal Dissipation	16.03 BTU/hr
Output Voltage Range	10-30V dc
Output Current Rating Per Point Per Module	2A maximum @ 60°C 10A maximum @ 60°C & 16A maximum @ 55°C (Linear derating)
Surge Current per Point	4A for 10ms each, repeatable every 2s
Minimum Load Current	3mA per point
Maximum On-State Voltage Drop	1.2V dc @ 2A
Max. Off-State Leakage Current	1mA per point
Output Delay Time OFF to ON ON to OFF	1ms maximum 5ms maximum
Diagnostic Functions: Short trip  Time stamp of diagnostics	>4.5A for 500µs maximum (Output ON, then short) >4.5A for 1.5ms maximum (Output ON into short) +/- 1ms
Scheduled Outputs	Synchronization within 16.7s maximum, reference to the CST
Fusing	Electronically fused per point
Configurable Fault States/Point	Hold Last State, ON or OFF (OFF is the default)
Configurable States in Program Mode/Point	Hold Last State, ON or OFF (OFF is the default)
Reverse Polarity Protection	None - If module is wired incorrectly, outputs may be damaged.
Isolation Voltage Channel to channel User side to system side	100% tested at 2546V dc for 1 second (250V ac maximum continuous voltage) 100% tested at 2546V dc for 1 second (250V ac maximum continuous voltage)
Module Keying (Backplane)	Software configurable
RTB Screw Torque (Cage clamp)	4.4 inch-pounds (0.4Nm) maximum
RTB Keying	User defined mechanical keying
RTB and Housing	36 Position RTB (1756-TBCH or TBS6H) <sup>1</sup>
Environmental Conditions Operating Temperature Storage Temperature Relative Humidity	0 to 60°C (32 to 140°F) -40 to 85°C (-40 to 185°F) 5 to 95% noncondensing
Conductors Wire Size  Category	22-14-gauge (2mm <sup>2</sup> ) stranded <sup>1</sup> 3/64 inch (1.2mm) insulation maximum <sup>1,2,3</sup>
Screwdriver Blade Width for RTB	1/8 inch (3.2mm) maximum
Agency Certification (when product or packaging is marked)	 Listed Industrial Control Equipment  Certified Process Control Equipment Certified Class I, Division 2, Group A, B, C, D  Approved Class I, Division 2, Group A, B, C, D  Marked for all applicable directives  Marked for all applicable acts N223

<sup>1</sup> Maximum wire size will require extended housing - 1756-TBE.

<sup>2</sup> Use this conductor category information for planning conductor routing as described in the system level installation manual.

<sup>3</sup> Refer to publication 1770-4.1 "Industrial Automation Wiring and Grounding Guidelines".

# 1756-OC8

## Configurable features

The following table lists the configurable features this module supports, the default value and the page of the feature's description:

Feature	Default value	Page of description
Communications Format	Output data	6-6
Program Mode	Off	6-11
Communications Failure in Program Mode	Disabled	6-11
Fault Mode	Off	6-11



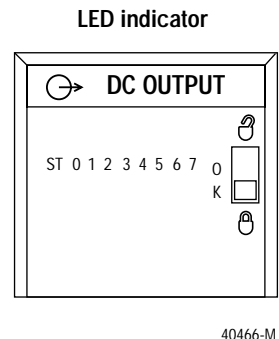
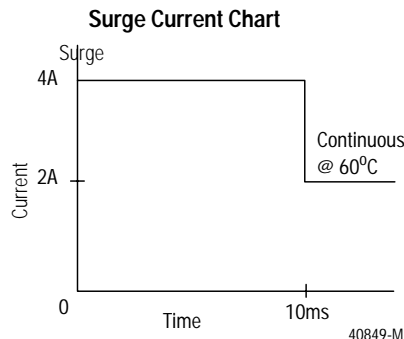
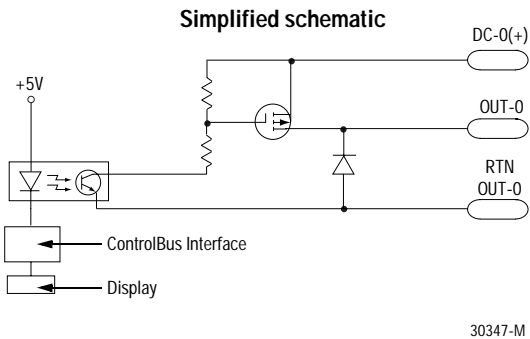
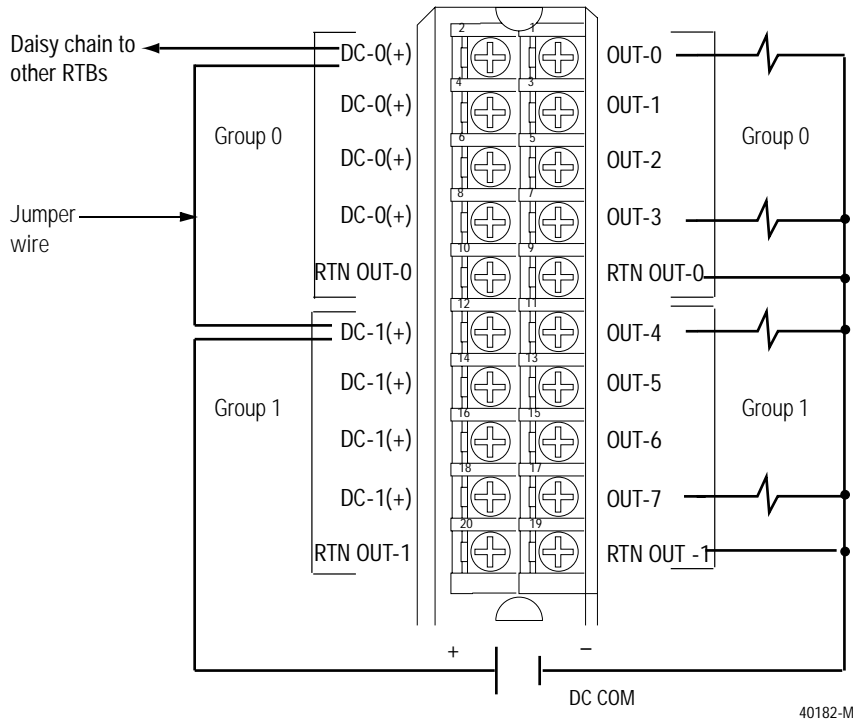

## Wiring example

Use the following example to wire your module.

- NOTES: **1.** All terminals with the same name are connected together on the module. For example, DC COM can be connected to either terminal marked RTN OUT-1.
- 2.** Do not physically connect more than two wires to a single RTB terminal. When you daisy chain from a group to another RTB, always connect the daisy chain as shown.
- 3.** This wiring example shows a single voltage source.
- 4.** If separate power sources are used, do not exceed the specified isolation voltage.



## 1756-OC8 Specifications

Number of Outputs	8 (4 points/common)
Module Location	1756 ControlLogix Chassis
Backplane Current	165mA @ 5.1V dc & 2mA @ 24V dc (Total backplane power 0.89W)
Maximum Power Dissipation (Module)	4.9W @ 60°C
Thermal Dissipation	16.71 BTU/hr
On State Voltage Range	30-60V dc
Output Current Rating Per Point Per Module	2A maximum @ 60°C 8A maximum @ 60°C
Surge Current per Point	4A for 10ms each, repeatable every 1s @ 60°C
Minimum Load Current	2mA per point
Maximum On-State Voltage Drop	2V dc @ 2A
Maximum Off-State Leakage Current	1mA per point
Output Delay Time OFF to ON ON to OFF	1ms maximum 2ms maximum
Scheduled Outputs	Synchronization within 16.7s maximum, reference to the CST
Configurable Fault States per Point	Hold Last State, ON or OFF (OFF is the default)
Configurable States in Program Mode per Point	Hold Last State, ON or OFF (OFF is the default)
Fusing	Not protected - Fused IFM is recommended to protect outputs (See publication 1492-2.12)
Reverse Polarity Protection	None - If the module is wired incorrectly, outputs may be damaged.
Isolation Voltage Group to group User to system	100% tested at 2546V dc for 1s (250V ac max. continuous voltage) 100% tested at 2546V dc for 1s (250V ac max. continuous voltage)
RTB Screw Torque (NEMA)	7-9 inch-pounds (0.8-1Nm)
Module Keying (Backplane)	Software configurable
RTB Keying	User defined mechanical keying
Field Wiring Arm and Housing	20 Position RTB (1756-TBNH or TBSH) <sup>1</sup>
Environmental Conditions Operating Temperature Storage Temperature Relative Humidity	0 to 60°C (32 to 140°F) -40 to 85°C (-40 to 185°F) 5 to 95% noncondensing
Conductors Wire Size Category	22-14-gauge (2mm <sup>2</sup> ) stranded <sup>1</sup> 3/64 inch (1.2mm) insulation maximum <sup>1, 2, 3</sup>
Screwdriver Blade Width for RTB	5/16 inch (8mm) maximum
Agency Certification (when product or packaging is marked)	 Listed Industrial Control Equipment  Certified Process Control Equipment Certified Class I, Division 2, Group A, B, C, D  Approved Class I, Division 2, Group A, B, C, D  Marked for all applicable directives  Marked for all applicable acts N223

<sup>1</sup> Maximum wire size will require extended housing - 1756-TBE.

<sup>2</sup> Use this conductor category information for planning conductor routing as described in the system level installation manual.

<sup>3</sup> Refer to publication 1770-4.1 "Industrial Automation Wiring and Grounding Guidelines".

# 1756-OH8I

## Configurable features

The following table lists the configurable features this module supports, the default value and the page of the feature's description:

Feature	Default value	Page of description
Communications Format	Output data	6-6
Program Mode	Off	6-11
Communications Failure in Program Mode	Disabled	6-11
Fault Mode	Off	6-11

## Wiring example

Use the following example to wire your module.

- NOTES: **1.** All terminals with the same name are connected together on the module. For example, the load can be connected to either terminal marked OUT-0.
- 2.** Do not physically connect more than two wires to a single RTB terminal. When you daisy chain to other RTBs, always connect the daisy chain as shown.
- 3.** If separate power sources are used, do not exceed the specified isolation voltage.

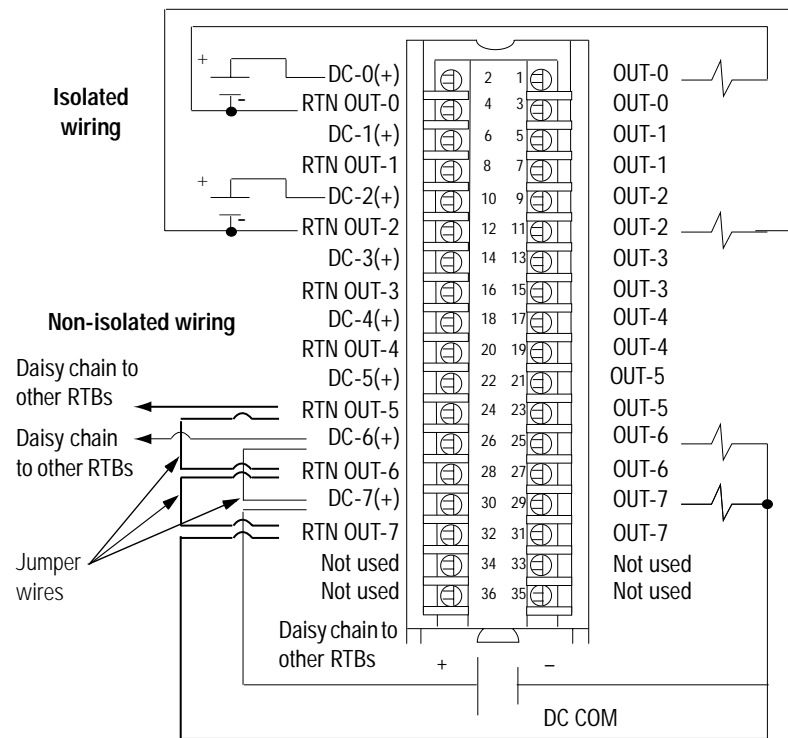

40169-M

Simplified schematic

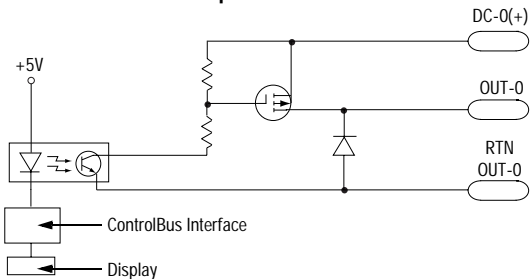

30347-M

Surge Current Chart

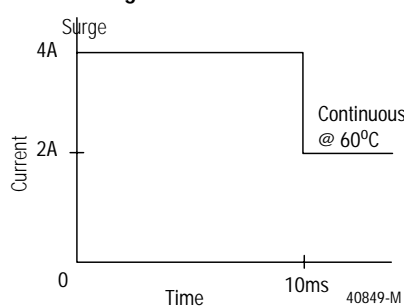



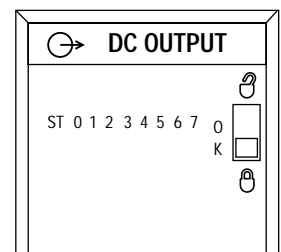

40849-M

LED indicator



40466-M

## 1756-OH8I Specifications

Number of Outputs	8 (individually isolated)
Module Location	1756 ControlLogix Chassis
Backplane Current	210mA @ 5.1V dc & 2mA @ 24V dc (Total backplane power 1.11W)
Maximum Power Dissipation (Module)	3.3W @ 60°C
Thermal Dissipation	11.25 BTU/hr
On State Voltage Range	90-146V dc
Output Current Rating Per Point Per Module	2A maximum @ 60°C 8A maximum @ 60°C
Surge Current per Point	4A for 10ms each, repeatable every 1s @ 60°C
Minimum Load Current	2mA per point
Maximum On-State Voltage Drop	2V dc @ 2A
Maximum Off-State Leakage Current	1mA per point
Output Delay Time OFF to ON ON to OFF	2ms maximum 2ms maximum
Scheduled Outputs	Synchronization within 16.7 seconds maximum, reference to the CST
Configurable Fault States/Point	Hold Last State, ON or OFF (OFF is the default)
Configurable States in Program Mode per Point	Hold Last State, ON or OFF (OFF is the default)
Fusing	Not protected - Fused IFM is recommended to protect outputs (See publication 1492-2.12)
Reverse Polarity Protection	None - If module is wired incorrectly, outputs may be damaged.
Isolation Voltage Channel to channel User to system	100% tested at 2546V dc for 1 second (250V ac maximum continuous voltage) 100% tested at 2546V dc for 1 second (250V ac maximum continuous voltage)
Module Keying (Backplane)	Software configurable
RTB Screw Torque (Cage clamp)	4.4 inch-pounds (0.4Nm) maximum
RTB Keying	User defined mechanical keying
RTB and Housing	36 Position RTB (1756-TBCH or TBS6H) <sup>1</sup>
Environmental Conditions Operating Temperature Storage Temperature Relative Humidity	0 to 60°C (32 to 140°F) -40 to 85°C (-40 to 185°F) 5 to 95% noncondensing
Conductors    Wire Size Category	22-14-gauge (2mm <sup>2</sup> ) stranded <sup>1</sup> 3/64 inch (1.2mm) insulation maximum <sup>1, 2, 3</sup>
Screwdriver Blade Width for RTB	1/8 inch (3.2mm) maximum
Agency Certification (when product is marked)	 Listed Industrial Control Equipment  Certified Process Control Equipment Certified Class I, Division 2, Group A, B, C, D  Approved Class I, Division 2, Group A, B, C, D  Marked for all applicable directives  Marked for all applicable acts N223

<sup>1</sup> Maximum wire size will require extended housing - 1756-TBE.

<sup>2</sup> Use this conductor category information for planning conductor routing as described in the system level installation manual.

<sup>3</sup> Refer to publication 1770-4.1 'Industrial Automation Wiring and Grounding Guidelines'.

# 1756-ON8

## Configurable features

The following table lists the configurable features this module supports, the default value and the page of the feature's description:

Feature	Default value	Page of description
Communications Format	Output data	6-6
Program Mode	Off	6-11
Communications Failure in Program Mode	Disabled	6-11
Fault Mode	Off	6-11

## Wiring example

Use the following example to wire your module.

- NOTES:
1. All terminals with the same name are connected together on the module. For example, L1 can be connected to any terminal marked L1-1.
  2. Do not physically connect more than two wires to a single RTB terminal. When you daisy chain from a group to another RTB, always connect the daisy chain as shown.
  3. This wiring example shows a single voltage source.
  4. If separate power sources are used, do not exceed the specified isolation voltage.

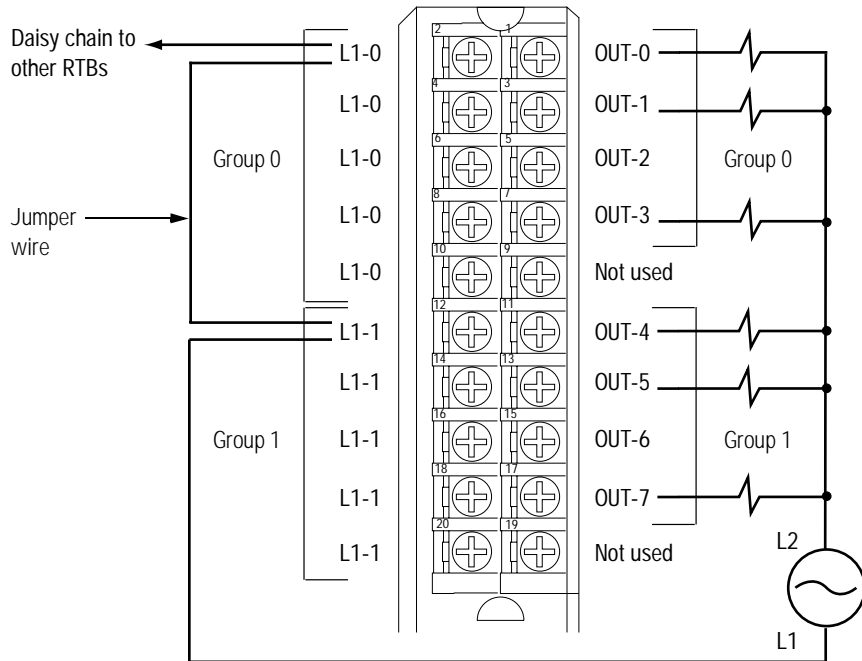

40184-M

Simplified schematic

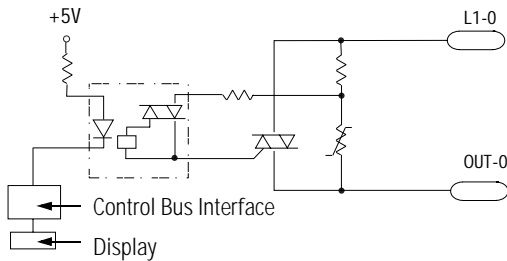

41161-M

Surge Current Chart

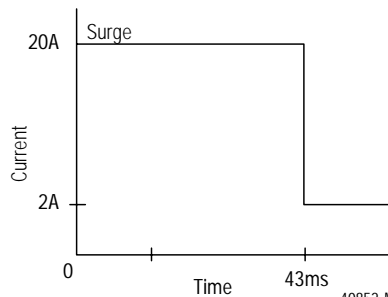



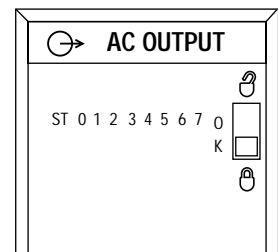

40852-M

LED indicator



20978-M

## 1756-ON8 Specifications

Number of Outputs	8 (4 points/common)
Module Location	1756 ControlLogix Chassis
Backplane Current	200mA @ 5.1V dc & 2mA @ 24V dc (Total backplane power 1.07)
Maximum Power Dissipation (Mod.)	5.1W @ 60°C
Thermal Dissipation	17.39 BTU/hr
Output Voltage Range	10-30V ac, current>50ma 47-63Hz 16-30V ac, current<50ma 47-63Hz
Output Current Rating Per Point Per Module	2A max. @ 60°C 5A max. @ 30°C; 4A max. @ 60°C (Linear derating)
Surge Current per Point	20A for 43ms each, repeatable every 2s @ 60°C
Min. Load Current	10mA per point
Max. On-State Voltage Drop	1.5V peak @ 2A & 6V peak @ load current<50mA
Max. Off-State Leakage Current	3mA per point
Commutating Voltage	4V/μs for loads>50mA 0.2V/μs for loads<50mA <sup>1</sup>
Output Delay Time OFF to ON ON to OFF	9.3ms @ 60Hz; 11ms @ 50Hz 9.3ms @ 60Hz; 11ms @ 50Hz
Scheduled Outputs	Synchronization within 16.7s maximum, reference to the CST
Configurable Fault States per Point	Hold Last State, ON or OFF (OFF is the default)
Configurable States in Program Mode per Point	Hold Last State, ON or OFF (OFF is the default)
Fusing	Not protected - Fused IFM is recommended to protect outputs (See publication 1492-2.12)
Isolation Voltage Group to group User to system	100% tested at 2546V dc for 1s (250V ac max. continuous voltage) 100% tested at 2546V dc for 1s (250V ac max. continuous voltage)
RTB Screw Torque (NEMA)	7-9 inch-pounds (0.8-1Nm)
Module Keying (Backplane)	Software configurable
RTB Keying	User defined mechanical keying
Field Wiring Arm and Housing	20 Position RTB (1756-TBNH or TBSH) <sup>2</sup>
Environmental Conditions Operating Temperature Storage Temperature Relative Humidity	0 to 60°C (32 to 140°F) -40 to 85°C (-40 to 185°F) 5 to 95% noncondensing
Conductors Wire Size Category	22-14-gauge (2mm <sup>2</sup> ) stranded <sup>2</sup> 3/64 inch (1.2mm) insulation maximum 1 <sup>3, 4</sup>
Screwdriver Blade Width for RTB	5/16 inch (8mm) maximum
Agency Certification (when product or packaging is marked)	 Listed Industrial Control Equipment  Certified Process Control Equipment Certified Class I, Division 2, Group A, B, C, D  Approved Class I, Division 2, Group A, B, C, D  Marked for all applicable directives  Marked for all applicable acts N223

<sup>1</sup> The commutating dv/dt of the output voltage (OUTPUT TO L2) should not exceed 0.2V/μs for loads under 50mA. The commutating dv/dt rating of the module for loads 50-500mA (OUTPUT TO L2) is 4V/μs maximum. If the commutating dv/dt rating of the TRIAC is exceeded, the TRIAC could latch on. If the commutating dv/dt rating is exceeded in the 10-50mA range, a resistor may be added across the output and L2. The purpose of this resistor is to increase the total output current to 50mA (I=V/R). At 50mA and above, the module has a higher commutating dv/dt rating. When adding a resistor for the output to L2, be sure it is rated for the power that it will dissipate (P=(V\*\*2)/R). If the commutating dv/dt rating is exceeded in the 50-500mA range, the L1 AC waveform could be at fault. Be sure the waveform is a good sinusoid, void if any anomalies such as distorted or flattened sections.

<sup>2</sup> Maximum wire size will require extended housing - 1756-TBE.

<sup>3</sup> Use this conductor category information for planning conductor routing as described in the system level installation manual.

<sup>4</sup> Refer to publication 1770-4.1 'Industrial Automation Wiring and Grounding Guidelines'.

# 1756-OV16E

## Configurable features

The following table lists the configurable features this module supports, the default value and the page of the feature's description:

Feature	Default value	Page of description
Communications Format	CST timestamped fuse data - output data	6-6
Program Mode	Off	6-11
Communications Failure in Program Mode	Disabled	6-11
Fault Mode	Off	6-11



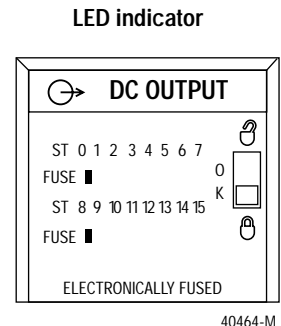
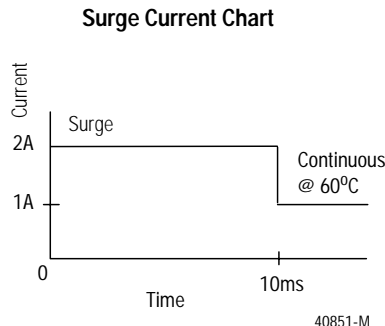
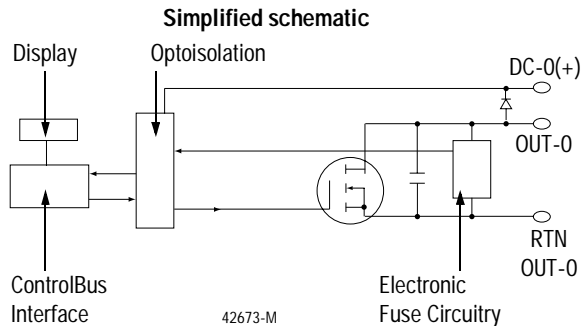
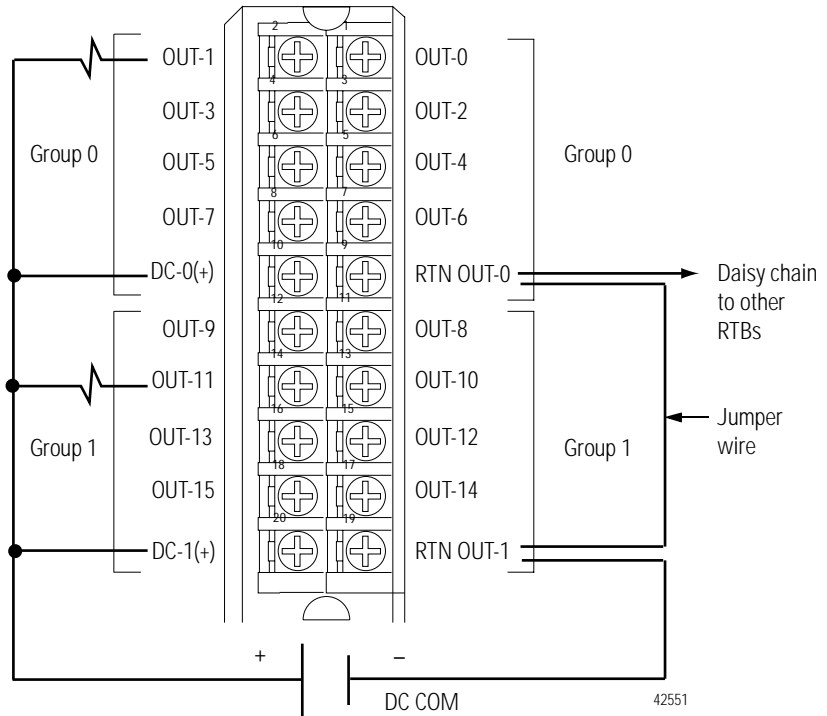

## Wiring example

Use the following example to wire your module.

- NOTES: 1. Do not physically connect more than two wires to a single RTB terminal. When you daisy chain from a group to another RTB, always connect the daisy chain as shown.
2. This wiring example shows a single voltage source.
3. If separate power sources are used, do not exceed the specified isolation voltage.
4. If separate power sources are used, do not exceed the specified isolation voltage.



## 1756-OV16E Specifications

Number of Outputs	16 (8 points/common)
Module Location	1756 ControlLogix Chassis
Backplane Current	210mA @ 5.1V dc & 2mA @ 24V dc (Total backplane power 1.12W)
Maximum Power Dissipation (Module)	6.72W @ 60°C
Thermal Dissipation	22.94 BTU/hr
Output Voltage Range	10-30.0V dc
Output Current Rating Per Point Per Module	1A maximum @ 60°C 8A maximum @ 60°C
Surge Current per Point	2A for 10ms each, repeatable every 2s @ 60°C
Minimum Load Current	2mA per output
Maximum On-State Voltage Drop	700mV dc @ 1A
Maximum Off-State Leakage Current	1mA per point
Output Delay Time OFF to ON ON to OFF	1ms maximum 1ms maximum
Diagnostic Functions: Short Trip  Timestamp of diagnostics	5A for 20mS @ 24V dc (Output ON, then shorted) 5A for 20mS @ 24V dc (Output turned ON into short) +/- 1ms
Scheduled Outputs	Synchronization within 16.7s maximum, reference to the CST
Configurable Fault States per Point	Hold Last State, ON or OFF (OFF is the default)
Configurable States in Program Mode per Point	Hold Last State, ON or OFF (OFF is the default)
Fusing	Electronically fused per group
Reverse Polarity Protection	None - If module is wired incorrectly, outputs may be damaged.
Isolation Voltage Group to group User to system	100% tested at 2546V dc for 1s (250V ac max. continuous voltage) 100% tested at 2546V dc for 1s (250V ac max. continuous voltage)
RTB Screw Torque (NEMA clamp)	7-9 inch-pounds (0.8-1Nm)
Module Keying (Backplane)	Software configurable
RTB Keying	User defined mechanical keying
Field Wiring Arm and Housing	20 Position RTB (1756-TBNH or TBSH) <sup>1</sup>
Environmental Conditions Operating Temperature Storage Temperature Relative Humidity	0 to 60°C (32 to 140°F) -40 to 85°C (-40 to 185°F) 5 to 95% noncondensing
Conductors Wire Size  Category	22-14-gauge (2mm <sup>2</sup> ) stranded <sup>1</sup> 3/64 inch (1.2mm) insulation maximum <sup>1,2,3</sup>
Screwdriver Blade Width for RTB	5/16 inch (8mm) maximum
Agency Certification (when product is marked)	 Listed Industrial Control Equipment  Certified Process Control Equipment Certified Class I, Division 2, Group A, B, C, D  Approved Class I, Division 2, Group A, B, C, D  Marked for all applicable directives  Marked for all applicable acts N223

<sup>1</sup> Maximum wire size will require extended housing - 1756-TBE.

<sup>2</sup> Use this conductor category information for planning conductor routing as described in the system level installation manual.

<sup>3</sup> Refer to publication 1770-4.1 "Industrial Automation Wiring and Grounding Guidelines".

# 1756-OW16I

## Configurable features

The following table lists the configurable features this module supports, the default value and the page of the feature's description:

Feature	Default value	Page of description
Communications Format	Output data	6-6
Program Mode	Off	6-11
Communications Failure in Program Mode	Disabled	6-11
Fault Mode	Off	6-11

## Wiring example

Use the following example to wire your module.

- NOTES:
1. All terminals with the same name are connected together on the module. For example, L1 can be connected to either terminal marked L1-15.
  2. Do not physically connect more than two wires to a single RTB terminal. When you use the second L1-15 terminal to daisy chain to other RTBs, always connect the daisy chain as shown.
  3. When using the **jumper bar** to daisy chain terminals together as shown, the **maximum current** you may apply to the module through a **single contact point** is **8A**.
  4. The **jumper bar** part number is 97739201. Contact your local Rockwell Automation sales representative to order additional jumper bars, if necessary.
  5. If separate power sources are used, do not exceed the specified isolation voltage.

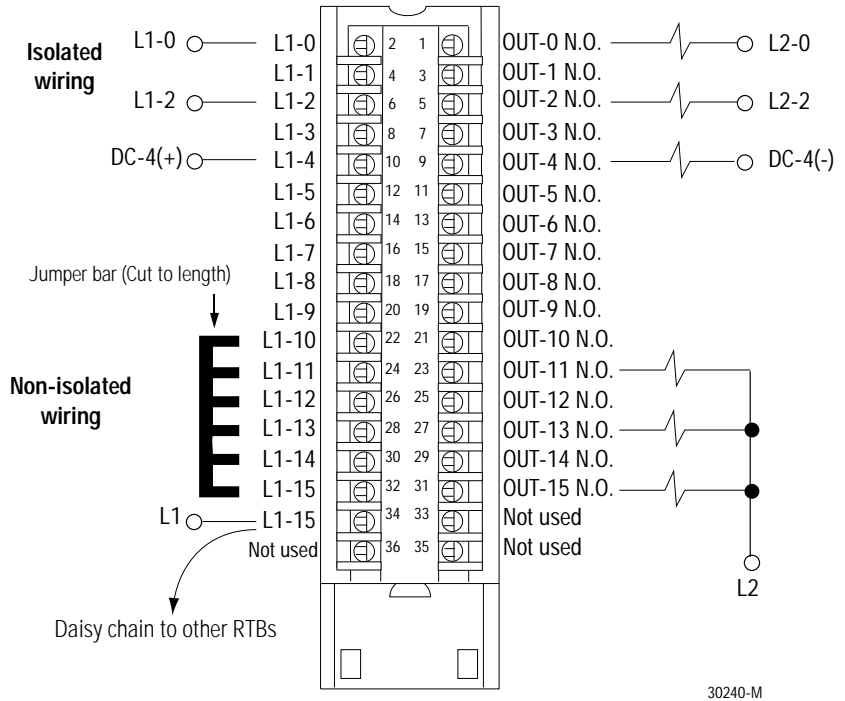

30240-M

### Simplified schematic

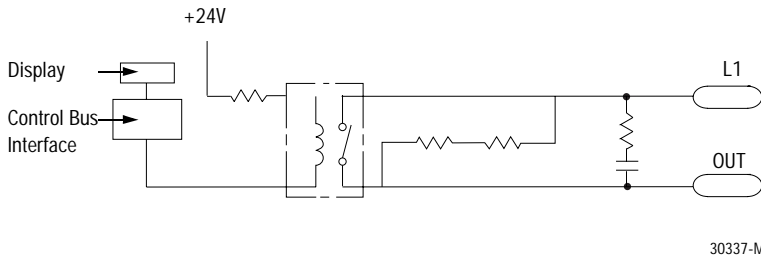

30337-M



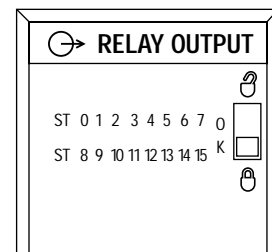

### LED indicator



40455-M

## 1756-OW16I Specifications

Specification:	Value:
Number of Outputs	16 N.O. (Contacts individually isolated)
Module Location	1756 ControlLogix Chassis
Backplane Current	150mA @ 5.1V dc & 150mA @ 24V dc (Total backplane power 4.37W)
Maximum Power Dissipation (Module)	4.5W @ 60°C
Thermal Dissipation	15.35 BTU/hr
Output Voltage Range	10-265V 47-63Hz/5-150V dc
Output Voltage Range (load dependent)	5-30V dc @ 2A resistive 48V dc @ 0.5A resistive 125V dc @ 0.25A resistive 125V ac @ 2A resistive 240V ac @ 2A resistive
Output Current Rating (at rating power)	<u>Resistive</u> 2A @ 5-30V dc 0.5A @ 48V dc 0.25V @ 125V dc 2A @ 125V ac 2A @ 240V ac <u>Inductive</u> 2A steady state @ 5-30V dc 0.5A steady state @ 48V dc 0.25A steady state @ 125V dc 2A steady state, 15A make @ 125V ac 2A steady state, 15A make @ 240 V ac
Maximum Off-State Leakage Current	1.5mA per point
Output Delay Time Off to On On to Off	10ms maximum 10ms maximum
Configurable Fault States Per Point	Hold Last State, ON or OFF (OFF is the default)
Configurable States in Program Mode per Point	Hold Last State, ON or OFF (OFF is the default)
Module Keying (Backplane)	Software configurable
RTB Keying	User defined mechanical keying
Conductors Wire Size	22-14-gauge (2mm <sup>2</sup> ) stranded <sup>1</sup> 3/64 inch (1.2mm) insulation maximum <sup>1,2,3</sup>
Category	

Specification:	Value:
UL Ratings	C300, R150 Pilot Duty
Minimum Load Current	10mA per point
Initial Contact Resistance	30mΩ
Switching Frequency	1 operation/3s (0.3Hz at rated load) maximum
Bounce Time	1.2ms (mean)
Expected Contact Life	300k cycles resistive/100k cycles inductive
Isolation Voltage Channel to channel User to system	100% tested at 2546V dc for 1s (265V ac maximum continuous voltage) 100% tested at 2546V dc for 1s (265V ac maximum continuous voltage)
Power Rating (steady state)	250W maximum for 125V ac resistive output 480W maximum for 240V ac resistive output 60W maximum for 30V dc resistive output 24W maximum for 48V dc resistive output 31W maximum for 125V dc resistive output 250VA maximum for 125V ac inductive output 480VA maximum for 240V ac inductive output 60VA maximum for 30V dc inductive output 24VA maximum for 48V dc inductive output 31VA maximum for 125V dc inductive output
Fusing	Not protected - Fused IFM is recommended to protect outputs (See publication 1492-2.12)
Environmental Conditions Operating Temperature Storage Temperature Relative Humidity	0 to 60°C (32 to 140°F) -40 to 85°C (-40 to 185°F) 5 to 95% noncondensing
Scheduled Outputs	Synchronization within 16.7s maximum, reference to the CST
RTB Screw Torque (Cage clamp)	4.4 inch-pounds (0.4Nm) maximum
Screwdriver Blade Width for RTB	1/8 inch (3.2mm) maximum
RTB and Housing	36 Position RTB (1756-TBCH or TBS6H) <sup>1</sup>
Agency Certification (when product or packaging is marked)	 Listed Industrial Control Equipment  Certified Process Control Equipment Certified Class I, Division 2, Group A, B, C, D  Approved Class I, Division 2, Group A, B, C, D  Marked for all applicable directives  Marked for all applicable acts N223

<sup>1</sup> Maximum wire size will require extended housing - 1756-TBE.

<sup>2</sup> Use this conductor category information for planning conductor routing as described in the system level installation manual.

<sup>3</sup> Refer to publication 1770-4.1, "Programmable Controller Wiring and Grounding Guidelines"

# 1756-OX8I

## Configurable features

The following table lists the configurable features this module supports, the default value and the page of the feature's description:

Feature	Default value	Page of description
Communications Format	Output data	6-6
Program Mode	Off	6-11
Communications Failure in Program Mode	Disabled	6-11
Fault Mode	Off	6-11

## Wiring example



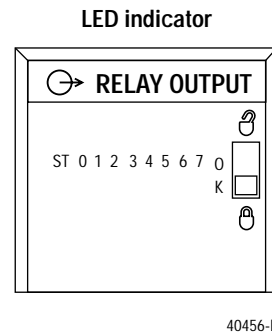
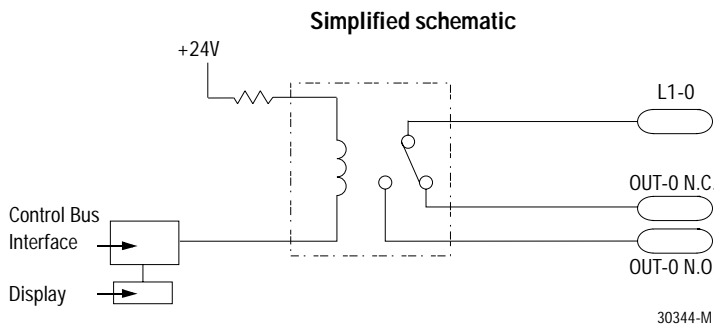
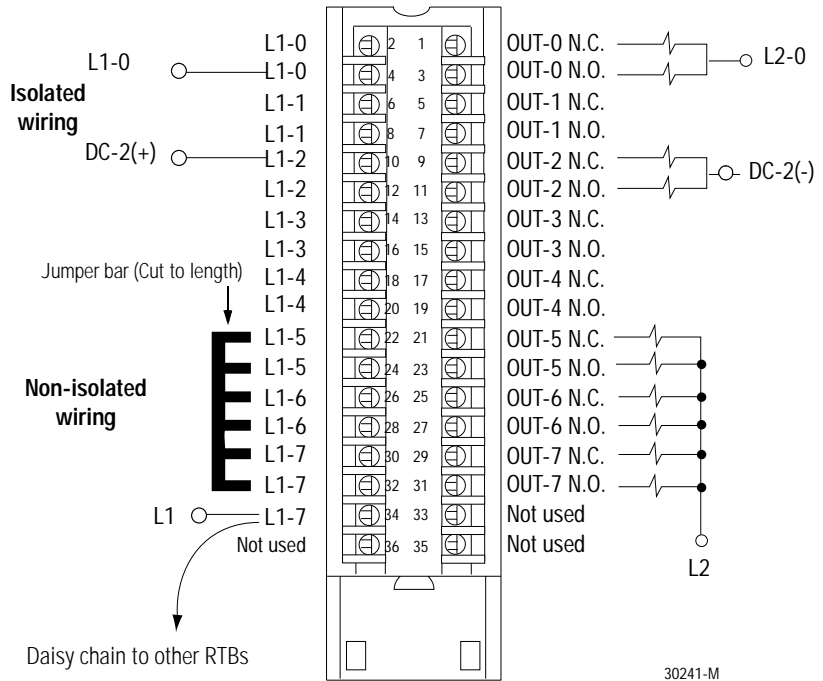

Use the following example to wire your module.

- NOTES:
1. All terminals with the same name are connected together on the module. For example, L1-0 can be connected to either terminal marked L1-0.
  2. Do not physically connect more than two wires to a single RTB terminal. When you use the third L1-7 terminal to daisy chain to other RTBs, always connect the daisy chain to the terminal directly connected to the supply wire, as shown.
  3. When using the **jumper bar** to daisy chain terminals together as shown, the **maximum current** you may apply to the module through a **single contact point is 8A**.
  4. The **jumper bar** part number is 97739201. Contact your local Rockwell Automation sales representative to order additional jumper bars, if necessary.
  5. If separate power sources are used, do not exceed the specified isolation voltage.



## 1756-OX8I Specifications

Specification:	Value:
Number of Outputs	8 N.O. & 8 N.C. (2 points/common)
Module Location	1756 ControlLogix Chassis
Backplane Current	100mA @ 5.1V dc & 100mA @ 24V dc (Total backplane power 2.91W)
Maximum Power Dissipation (Module)	3.1W @ 60°C
Thermal Dissipation	10.57 BTU/hr
Output Voltage Range	10-265V 47-63Hz/5-150V dc
Output Voltage Range (load dependent)	5-30V dc @ 2A resistive 48V dc @ 0.5A resistive 125V dc @ 0.25A resistive 125V ac @ 2A resistive 240V ac @ 2A resistive
Output Current Rating (at rating power)	<u>Resistive</u> 2A @ 5-30V dc 0.5A @ 48V dc 0.25A @ 125V dc 2A @ 125V ac 2A @ 240V ac <u>Inductive</u> 2A steady state @ 5-30V dc 0.5A steady state @ 48V dc 0.25A steady state @ 125V dc 2A steady state, 15A make @ 125V ac 2A steady state, 15A make @ 240 V ac
Maximum Off-State Leakage Current	0mA
Output Delay Time Off to on On to off	13ms maximum 13ms maximum
Configurable Fault States per Point	Hold Last State, ON or OFF (OFF is the default)
Configurable States in Program Mode per Point	Hold Last State, ON or OFF (OFF is the default)
Module Keying (Backplane)	Software configurable
RTB Keying	User defined mechanical keying
Conductors Wire Size  Category	22-14-gauge (2mm <sup>2</sup> ) stranded <sup>1</sup> 3/64 inch (1.2mm) insulation maximum <sup>2, 3</sup>

Specification:	Value:
UL Ratings	C300, R150 Pilot Duty
Minimum Load Current	10mA per point
Initial Contact Resistance	30mΩ
Switching Frequency	1 operation/3s (0.3Hz at rated load) maximum
Bounce Time	1.2ms (mean)
Expected Contact Life	300k cycles resistive/100k cycles inductive
Isolation Voltage Channel to channel  User to system	100% tested at 2546V dc for 1s (265V ac maximum continuous voltage) 100% tested at 2546V dc for 1s (265V ac maximum continuous voltage)
Power Rating (steady state)	250W maximum for 125V ac resistive output 480W maximum for 240V ac resistive output 60W maximum for 30V dc resistive output 24W maximum for 48V dc resistive output 31W maximum for 125V dc resistive output 250VA maximum for 125V ac inductive output 480VA maximum for 240V ac inductive output 60VA maximum for 30V dc inductive output 24VA maximum for 48V dc inductive output 31VA maximum for 125V dc inductive output
Fusing	None - Fused IFM is recommended to protect outputs (See pub. 1492-2.12)
Environmental Conditions Operating Temperature Storage Temperature Relative Humidity	0 to 60°C (32 to 140°F) -40 to 85°C (-40 to 185°F) 5 to 95% noncondensing
Scheduled Outputs	Synchronization within 16.7s maximum, reference to the CST
RTB Screw Torque (Cage clamp)	4.4 inch-pounds (0.4Nm) maximum
Screwdriver Blade Width for RTB	1/8 inch (3.2mm) maximum
RTB and Housing	36 Position RTB (1756-TBCH or TBS6H) <sup>1</sup>
Agency Certification (when product or packaging is marked)	 Listed Industrial Control Equipment  Certified Process Control Equipment Certified Class I, Division 2, Group A, B, C, D  Approved Class I, Division 2, Group A, B, C, D  Marked for all applicable directives  Marked for all applicable acts N223

<sup>1</sup> Maximum wire size will require extended housing - 1756-TBE.

<sup>2</sup> Use this conductor category information for planning conductor routing as described in the system level installation manual.

<sup>3</sup> Refer to publication 1770-4.1, "Programmable Controller Wiring and Grounding Guidelines"

## **Chapter Summary and What's Next**

In this chapter you learned about module specific information. Move on to Chapter 8, Troubleshooting Your Module.

## Troubleshooting Your Module

**What This Chapter Contains** This chapter describes the indicators on the ControlLogix digital modules and how to use them to troubleshoot the module. The following table describes what this chapter contains and its location.

For information about:	See page:
Using Indicators to Troubleshoot Your Module	8-1
Using RSLogix 5000 to Troubleshoot Your Module	8-4
Chapter Summary and What's Next	8-6

### Using Indicators to Troubleshoot Your Module

Each ControlLogix I/O module has indicators which show individual I/O state (yellow), fault, or fuse status (red). A bi-colored LED indicates module status with an "OK" (red/green). LED indicators are located on the front of the module.

### LED indicators for input modules

**Table 8.A**  
Status Indicators for Input Modules

LED indicators:	This display:	Means:	Take this action:
OK	Green light	The inputs are being multicast and in normal operating state.	None
OK	Flashing green light	The module has passed internal diagnostics but is not multicasting inputs or it is inhibited.	None
OK	Flashing red light	Previously established communication has timed out.	Check controller and chassis communication.
OK	Red light	The module must be replaced.	Replace the module.
I/O State	Yellow	The input is active.	None
I/O Fault	Red	A fault has occurred for this point.	Check this point at the controller.

The following LED indicators are used with input modules:

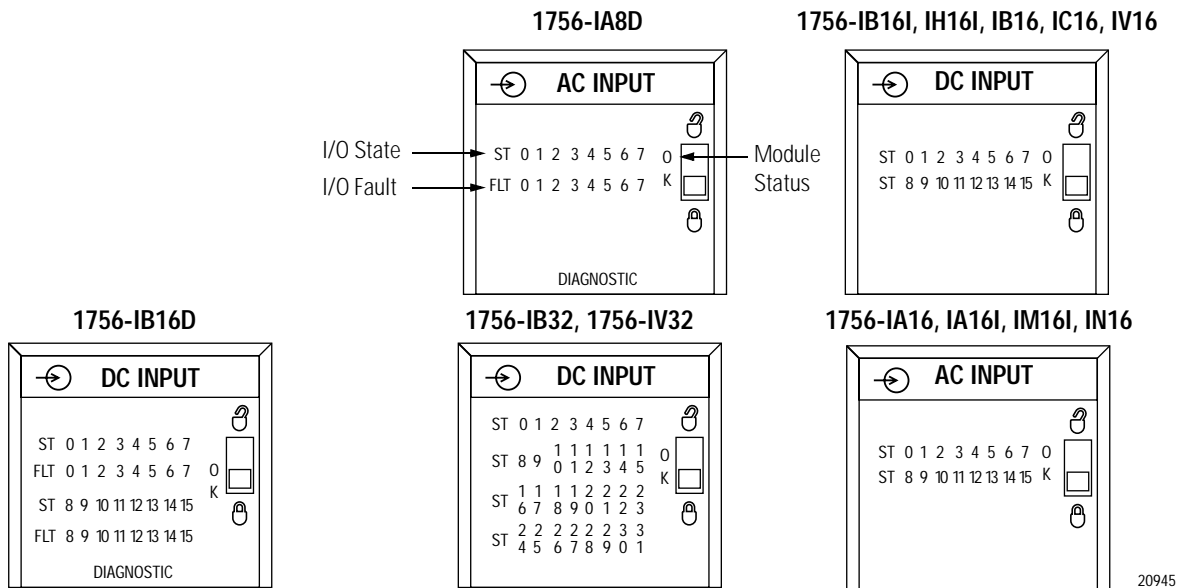

20945

### LED indicators for output modules

**Table 8.B**  
Status Indicators for Output Modules

LED indicators	This display:	Means:	Take this action:
OK	Steady green light	The outputs are actively being controlled by a system processor.	None
OK	Flashing green light	The module has passed internal diagnostics but is not actively controlled or it is inhibited.	None
OK	Flashing red light	Previously established communication has timed out.	Check controller and chassis communication.
OK	Steady red light	The module must be replaced.	Replace the module.
I/O State	Yellow	The output is active.	None
I/O Fuse	Red	A short overload fault has occurred for a point in this group.	Check wiring for short overload. Check the module properties in RSLogix 5000 and reset the fuse.
I/O Fault	Red	A fault has occurred for this point.	Check this point at the controller.

The following LED indicators are used with output modules.

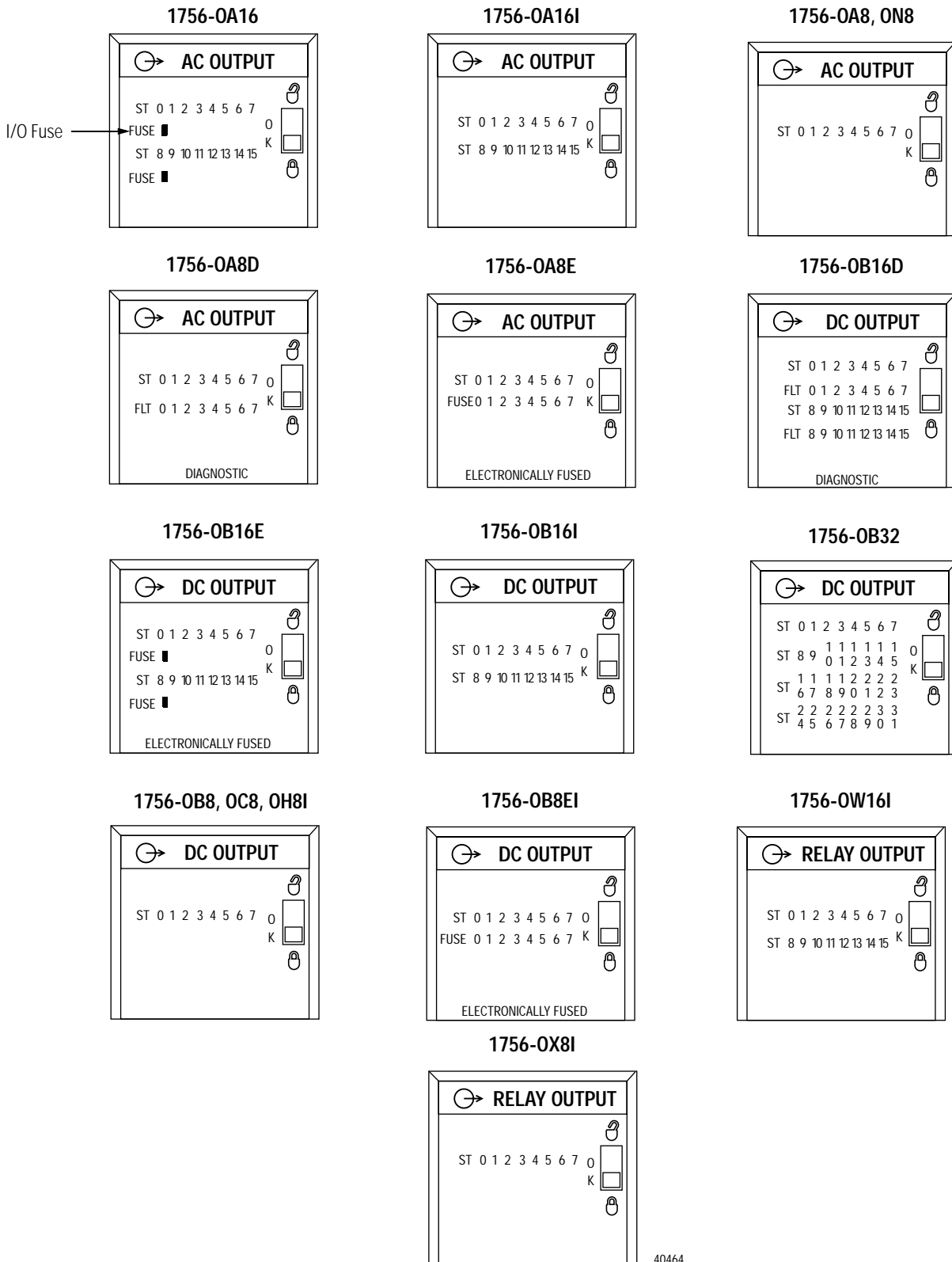

40464

## Using RSLogix 5000 to Troubleshoot Your Module

In addition to the LED display on the module, RSLogix 5000 will alert you to fault and other conditions. You will be alerted in one of three ways:

- Warning signal on the main screen next to the module-This occurs when the connection to the module is broken
- Message in a screen's status line
- Notification in the Tag Editor - General module faults are also reported in the Tag Editor. Diagnostic faults are **only** reported in the Tag Editor
- Status on the Module Info page

The screens below display fault notification in RSLogix 5000.

### Warning signal on main screen

 Warning icon when a communications fault occurs or if the module is inhibited

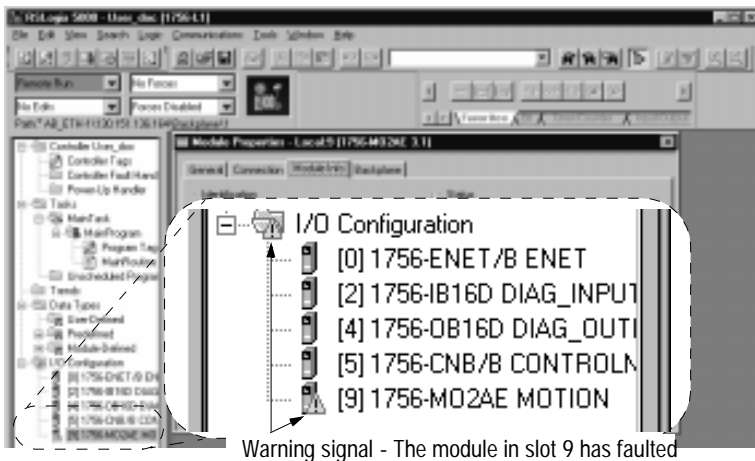

### Fault message in status line

Status line provides information on the module's fault and on the connection to the module

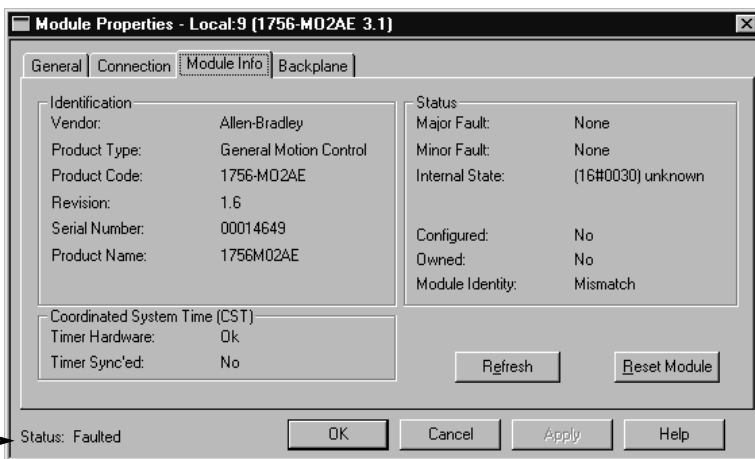

### Notification in Tag Editor

A fault has occurred for any point that lists the number 1 in the Fault line

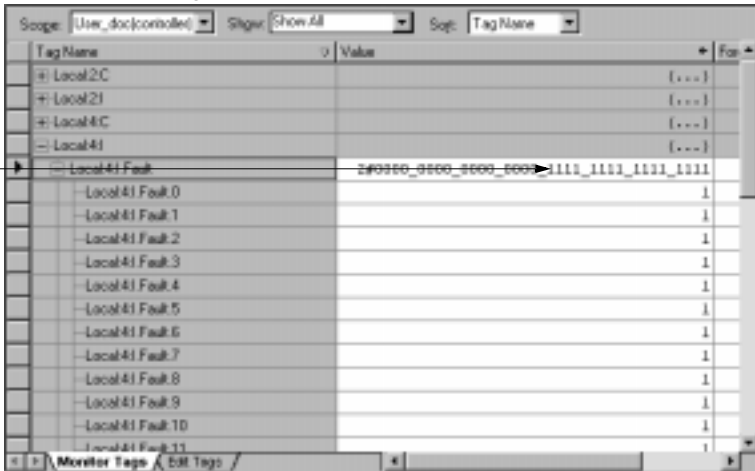

### Determining Fault Type

When you are monitoring a module's configuration properties in RSLogix 5000 and receive a Communications fault message, the Connection page lists the type of fault.

The fault type is listed here

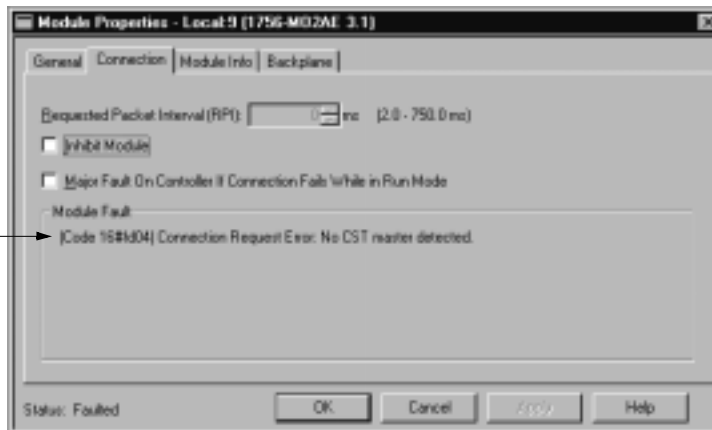

For a detailed listing of the possible faults, their causes and suggested solutions, see Module Faults in the online help.

## **Chapter Summary and What's Next**

In this chapter you learned about troubleshooting the module.

Move on to Appendix A, Using Software Configuration Tags.

## Using Software Configuration Tags

---

**IMPORTANT**

Although this appendix presents the option of changing a module's configuration through the Tag Editor of RSLogix 5000, we suggest that you use the module's properties tabs to change configuration when possible.

---

When you create a module, module-defined data types and tags are created. These Tags allow you to access the Input and Output Data and Configuration of Data of the module via the controller's ladder logic.

The types of tags created vary for each module. There is also variation among the tags for any particular module, depending on which communications format you chose when creating a module.

For example, the 1756-IA16I module has four choices of Communications Formats: Input Data, CST Timestamped Input Data, Listen-Only Input Data, Listen-Only CST Timestamped Input Data. If you choose CST Timestamped Input Data, several more tags are created than if you choose Input Data.

The following screens show the difference between viewing change of state for a point on the 1756-IA16I module through the module's properties tabs and the Data Monitor in the Tag Editor.

**Module Properties**  
Change of state

Point	Enable Change of State		Enable Diagnostics for		Enable Diag. Latching
	Off -> On	On -> Off	Open Wire		
0	<input checked="" type="checkbox"/>	<input checked="" type="checkbox"/>	<input checked="" type="checkbox"/>	<input checked="" type="checkbox"/>	
1	<input checked="" type="checkbox"/>	<input checked="" type="checkbox"/>	<input checked="" type="checkbox"/>	<input checked="" type="checkbox"/>	
2	<input checked="" type="checkbox"/>	<input checked="" type="checkbox"/>	<input checked="" type="checkbox"/>	<input checked="" type="checkbox"/>	
3	<input checked="" type="checkbox"/>	<input checked="" type="checkbox"/>	<input checked="" type="checkbox"/>	<input checked="" type="checkbox"/>	
4	<input checked="" type="checkbox"/>	<input checked="" type="checkbox"/>	<input checked="" type="checkbox"/>	<input checked="" type="checkbox"/>	
5	<input checked="" type="checkbox"/>	<input checked="" type="checkbox"/>	<input checked="" type="checkbox"/>	<input checked="" type="checkbox"/>	
6	<input checked="" type="checkbox"/>	<input checked="" type="checkbox"/>	<input checked="" type="checkbox"/>	<input checked="" type="checkbox"/>	
7	<input checked="" type="checkbox"/>	<input checked="" type="checkbox"/>	<input checked="" type="checkbox"/>	<input checked="" type="checkbox"/>	
8	<input checked="" type="checkbox"/>	<input checked="" type="checkbox"/>	<input checked="" type="checkbox"/>	<input checked="" type="checkbox"/>	

Enable Change of State for Diagnostic Transitions

Status: Offline    OK    Cancel    Apply    Help

**Data Monitor**  
Change of state

Tag Name	Value	Style	Type
Local:2.C	{...}		AB 1756_
Local:2.C.DiagCDSDisable	0	Decimal	BOOL
Local:2.C.FilterOnOE_0_7	1	Decimal	SINT
Local:2.C.FilterOnOE_0_7	1	Decimal	SINT
Local:2.C.FilterOnOE_8_15	1	Decimal	SINT
Local:2.C.FilterOnOE_8_15	1	Decimal	SINT
Local:2.C.DOSOnOIE.n	2#000_0000_0000_00...	Binary	DINT
Local:2.C.DOSOnOIE.n.0	1	Decimal	BOOL
Local:2.C.DOSOnOIE.n.1	1	Decimal	BOOL
Local:2.C.DOSOnOIE.n.2	1	Decimal	BOOL
Local:2.C.DOSOnOIE.n.3	1	Decimal	BOOL
Local:2.C.DOSOnOIE.n.4	1	Decimal	BOOL
Local:2.C.DOSOnOIE.n.5	1	Decimal	BOOL
Local:2.C.DOSOnOIE.n.6	1	Decimal	BOOL
Local:2.C.DOSOnOIE.n.7	1	Decimal	BOOL

Both screens show the same feature on the module.

## Module Tag Names and Definitions

The set of tags associated with any module depends on the type of module and the Communications Format chosen during configuration.

### Standard Input Module Tags

Tables A.1 and A.2 list and define all tags that may be used for ControlLogix standard digital input modules. Input modules have two types of tags:

- configuration
- input data.

#### **IMPORTANT**

The table below lists all possible standard input module tags. In each application, though, the series of tags varies, depending on how the module is configured.

#### *Configuration Tags*

**Table A.1**  
**Standard Input Module Configuration Tags**

Name (as listed in the Tag Editor):	Configuration or I/O Data:	Definition:
<b>COSOnOffEn</b> (1bit per point)	Configuration	<b>Change of State ON to OFF</b> – Triggers an event in the controller for ON to OFF transition of input point and causes the input module to update the data table as soon as possible. The CST timestamp is also updated. <b>0=disable, 1=enable</b>
<b>COS OffOnEn</b> (1 bit per point)	Configuration	<b>Change of State OFF to ON</b> – Triggers an event in the controller for OFF to ON transition of input point and causes the input module to update the data table as soon as possible. The CST timestamp is also updated. <b>0=disable, 1=enable</b>
<b>FilterOnOff_0_7 etc.</b> (1 byte per group)	Configuration	Filter Times ON to OFF – Filter time for digital filter in digital input modules for ON to OFF transition. Operates on groups of 8 points. <b>Valid DC filter times=0, 1, 2, 9, 18ms</b> <b>Valid AC filter times=1, 2ms</b>
<b>FilterOffOn_0_7 etc.</b> (1 byte per group)	Configuration	<b>Filter Times OFF to ON</b> – Filter time for digital filter in digital input modules for OFF to ON transition. Operates on groups of 8 points. <b>Valid DC filter times=0, 1, 2ms</b> <b>Valid AC filter times=1, 2ms</b>

*Input Data Tags*

**Table A.2**  
**Standard Input Module Input Data Tags**

<b>Name (as listed in the Tag Editor):</b>	<b>Configuration or I/O Data:</b>	<b>Definition:</b>
<b>CSTTimestamp</b> (8 bytes)	Input data	<b>Coordinated System Time Timestamp</b> – Timestamp can be configured to indicate the time that data changed (see COSOffOnEn, COSOnOffEn, COSStatus, DiagCOSDisable) and/or the time that a diagnostic fault occurred (see OpenWireEn, FieldPwrLossEn).
<b>Data</b> (1 bit per point)	Input data	Off/On status for the input point. <b>0=Off, 1=On</b>
<b>Fault</b> (1 bit per point)	Input data	This is an ordered status of faults which indicates that a point is faulted and input data for that point may be incorrect. Check other diagnostic faults, if they are available, for further diagnosis of the root cause. If communication to the input module is lost, then all points for the module will be faulted. <b>0=no fault, 1=fault (OpenWire or FieldPwrLoss or Comm Fault)</b>

**Standard Output Module Tags**

Tables A.3 to A.5 list and define all tags that may be used for ControlLogix standard digital output modules. Output modules have three types of tags

- configuration
- input data
- output data.

**IMPORTANT**

The table below lists all possible standard output module tags. In each application, though, the series of tags varies, depending on how the module is configured.

*Configuration Tags*

**Table A.3**  
**Standard Output Module Configuration Tags**

<b>Name (as listed in the Tag Editor):</b>	<b>Configuration or I/O Data:</b>	<b>Definition:</b>
<b>FaultMode</b> (1 bit per point)	Configuration	<b>Fault Mode</b> – Used in conjunction with FaultValue to configure the state of outputs when a communications fault occurs. See FaultValue. <b>0=Use FaultValue (OFF or ON), 1=Hold Last State</b>
<b>FaultValue</b> (1 bit per point)	Configuration	<b>Fault Value</b> – Used in conjunction with FaultMode to configure the state of outputs when a communications fault occurs. See FaultMode. <b>0=OFF, 1=ON</b>

**Table A.3**  
**Standard Output Module Configuration Tags**

<b>Name (as listed in the Tag Editor):</b>	<b>Configuration or I/O Data:</b>	<b>Definition:</b>
<b>ProgMode</b> (1 bit per point)	Configuration	<b>Program Mode</b> – Used in conjunction with ProgValue to configure the state of outputs when the controller is in Program Mode. See ProgValue. <b>0=Use ProgValue (OFF or ON), 1=Hold Last State</b>
<b>ProgValue</b> (1 bit per point)	Configuration	<b>Program Value</b> – Used in conjunction with ProgMode to configure the state of outputs when the controller is in Program Mode. See ProgMode. <b>0=Off, 1=On</b>
<b>ProgToFaultEn</b> (1 byte per module)	Configuration	<b>Program to Fault Transition</b> – Diagnostic enables the transitioning of outputs to FaultMode if a communications failure occurs in Program Mode. Otherwise outputs will remain in ProgramMode. See ProgMode, ProgValue, FaultMode, FaultValue. 0=outputs stay in ProgramMode if comm failure 1=outputs got to FaultMode if comm failure

*Input Data Tags*

**Table A.4**  
**Standard Output Module Input Data Tags**

<b>Name (as listed in the Tag Editor):</b>	<b>Configuration or I/O Data:</b>	<b>Definition:</b>
<b>CSTimestamp</b> (8 bytes)	Input data	<b>Coordinated System Time Timestamp</b> – Timestamp of diagnostic input data including fusing (see BlownFuse, NoLoad, OutputVerifyFault, FieldPwrLoss), which is updated whenever a diagnostic fault occurs or goes away.
<b>Data</b> (1 bit per point)	Input data	<b>Data</b> – Off/On status for the output point ECHOED back from the output module. This is used to verify proper communication only. No field side verification is done. For field side verification, see OutputVerifyFault. <b>0=Off, 1=On</b>
<b>Fault</b> (1 bit per point)	Input data	This is an ordered status of faults which indicates that a point is faulted and I/O data for that point may be incorrect. Check other diagnostic faults, if they are available, for further diagnosis of the root cause. If communication to the input module is lost, then all points for the module will be faulted. <b>0=no fault, 1=fault (FuseBlown, NoLoad, OutputVerifyFault, FieldPwrLoss, or CommFault)</b>
<b>FuseBlown.</b> (1 bit per point)	Input Data	Fuse is Blown – An electronic or mechanical fuse has detected a short or overload condition for an output point. All FuseBlown conditions are latched and must be reset by the User. 0=no fault, 1=fault

*Output Data Tag*

**Table A.5  
Standard Output Module Output Data Tags**

<b>Name (as listed in the Tag Editor):</b>	<b>Configuration or I/O Data:</b>	<b>Definition:</b>
<b>CSTTimestamp</b> (8 bytes)	Output data	<b>Coordinated System Time Timestamp</b> – Timestamp to be used with Scheduled Outputs and Coordinated System Time (CST). Used to synchronize outputs across the system by indicating the time (CST Timestamp) at which the output module is to apply its outputs.
<b>Data</b> (1 bit per point)	Output data	Off/On status for the output point. originating from the controller <b>0=Off, 1=On</b>

**Diagnostic Input Module Tags**

Tables A.6 and A.7 list and define all tags that may be used for ControlLogix diagnostic digital input modules. Input modules have two types of tags

- configuration
- input data.

**IMPORTANT**

The table below lists all possible diagnostic input module tags. In each application, though, the series of tags varies, depending on how the module is configured.

*Configuration Tags*

**Table A.6  
Diagnostic Input Module Configuration Tags**

<b>Name (as listed in the Tag Editor):</b>	<b>Configuration or I/O Data:</b>	<b>Definition:</b>
<b>COSOnOffEn</b> (1bit per point)	Configuration	<b>Change of State ON to OFF</b> – Triggers an event in the controller for ON to OFF transition of input point and causes the input module to update the data table as soon as possible. The CST timestamp is also updated. <b>0=disable, 1=enable</b>
<b>COS OffOnEn</b> (1 bit per point)	Configuration	<b>Change of State OFF to ON</b> – Triggers an event in the controller for OFF to ON transition of input point and causes the input module to update the data table as soon as possible. The CST timestamp is also updated. <b>0=disable, 1=enable</b>
<b>DiagCOSDisable</b> (per module)	Configuration	<b>Diagnostic Change of State</b> – Triggers the module to transmit diagnostic status data with an updated timestamp as soon as the diagnostic data changes state

**Table A.6**  
**Diagnostic Input Module Configuration Tags**

<b>Name (as listed in the Tag Editor):</b>	<b>Configuration or I/O Data:</b>	<b>Definition:</b>
<b>FaultLatchEn</b> (1 bit per point)	Configuration	<b>Fault is Latched</b> – If enabled for a point, any OpenWire or FieldPwrLoss will stay latched in the faulted state even if the fault no longer exists until the User clears the fault. <b>0=disable, 1=enable latching</b>
<b>FieldPwrLossEn</b> (1 bit per point)	Configuration	<b>Field Power Loss</b> – Enables Field Power Loss diagnostic. <b>0=disable, 1=enable</b>
<b>FilterOnOff_0_7 etc.</b> (1 byte per group)	Configuration	Filter Times ON to OFF – Filter time for digital filter in digital input modules for ON to OFF transition. Operates on groups of 8 points. <b>Valid DC filter times=0, 1, 2, 9, 18ms</b> <b>Valid AC filter times=1, 2ms</b>
<b>FilterOffOn_0_7 etc.</b> (1 byte per group)	Configuration	<b>Filter Times OFF to ON</b> – Filter time for digital filter in digital input modules for OFF to ON transition. Operates on groups of 8 points. <b>Valid DC filter times=0, 1, 2ms</b> <b>Valid AC filter times=1, 2ms</b>
<b>OpenWireEn</b> (1 bit per point)	Configuration	<b>Open Wire</b> – Enables Open Wire diagnostic. <b>0=disable, 1=enable</b>

*Input Data Tags*

**Table A.7**  
**Diagnostic Input Module Input Data Tags**

<b>Name (as listed in the Tag Editor):</b>	<b>Configuration or I/O Data:</b>	<b>Definition:</b>
<b>CSTTimestamp</b> (8 bytes)	Input data	<b>Coordinated System Time Timestamp</b> – Timestamp can be configured to indicate the time that data changed (see COSOffOnEn, COSOnOffEn, COSStatus, DiagCOSDisable) and/or the time that a diagnostic fault occurred (see OpenWireEn, FieldPwrLossEn).
<b>Data</b> (1 bit per point)	Input data	Off/On status for the input point. <b>0=Off, 1=On</b>
<b>Fault</b> (1 bit per point)	Input data	This is an ordered status of faults which indicates that a point is faulted and input data for that point may be incorrect. Check other diagnostic faults, if they are available, for further diagnosis of the root cause. If communication to the input module is lost or inhibited, then all points for the module will be faulted by the processor. <b>0=no fault, 1=fault (OpenWire or FieldPwrLoss or Comm Fault)</b>
<b>FieldPwrLoss</b> (1 bit per point)	Input Data	<b>Field Power Loss</b> – AC input diagnostic detects that field power has failed or is disconnected from the module. Open Wire will also be detected. <b>0=no fault, 1=fault</b>
<b>OpenWire</b> (1 bit per point)	Input data	<b>Open Wire</b> – Diagnostic which detects that a wire has been disconnected from the input point. If a group of points all show this fault, then possibly the return (L1 or GND) is missing from the module. Also see FieldPwrLoss. <b>0=no fault, 1=fault</b>

## Diagnostic Output Module Tags

Tables A.8 to A.10 list and define all tags that may be used for ControlLogix diagnostic digital output modules. Output modules have three types of tags

- configuration
- input data
- output data.

**IMPORTANT**

The table below lists all possible diagnostic output module tags. In each application, though, the series of tags varies, depending on how the module is configured.

*Configuration Tags*

**Table A.8  
Diagnostic Output Module Configuration Tags**

Name (as listed in the Tag Editor):	Configuration or I/O Data:	Definition:
<b>FaultLatchEn</b> (1 bit per point)	Configuration	<b>Fault is Latched</b> – If enabled for a point, any NoLoad, OutputVerifyFault or FieldPwrLoss will stay latched in the faulted state even if the fault no longer exists until the User clears the fault. This does not affect FuseBlown; it is always latched. <b>0=disable, 1=enable latching</b>
<b>FaultMode</b> (1 bit per point)	Configuration	<b>Fault Mode</b> – Used in conjunction with FaultValue to configure the state of outputs when a communications fault occurs. See FaultValue. <b>0=Use FaultValue (OFF or ON), 1=Hold Last State</b>
<b>FaultValue</b> (1 bit per point)	Configuration	<b>Fault Value</b> – Used in conjunction with FaultMode to configure the state of outputs when a communications fault occurs. See FaultMode. <b>0=OFF, 1=ON</b>
<b>FieldPwrLossEn</b> (1 bit per point)	Configuration	<b>Field Power Loss</b> – Enables Field Power Loss diagnostic. <b>0=disable, 1=enable</b>
<b>NoLoadEn</b> (1 bit per point)	Configuration	<b>No Load</b> – Enables No Load diagnostic. <b>0=disable, 1=enable</b>
<b>OutputVerifyEn</b> (1 bit per point)	Configuration	<b>Output Verify</b> – Enables Output Verify diagnostic. <b>0=disable, 1=enable</b>

**Table A.8**  
**Diagnostic Output Module Configuration Tags**

<b>Name (as listed in the Tag Editor):</b>	<b>Configuration or I/O Data:</b>	<b>Definition:</b>
<b>ProgMode</b> (1 bit per point)	Configuration	<b>Program Mode</b> – Used in conjunction with ProgValue to configure the state of outputs when the controller is in Program Mode. See ProgValue. <b>0=Use ProgValue (OFF or ON), 1=Hold Last State</b>
<b>ProgValue</b> (1 bit per point)	Configuration	<b>Program Value</b> – Used in conjunction with ProgMode to configure the state of outputs when the controller is in Program Mode. See ProgMode. <b>0=Off, 1=On</b>
<b>ProgToFaultEn</b> (1 byte per module)	Configuration	<b>Program to Fault Transition</b> – Diagnostic enables the transitioning of outputs to FaultMode if a communications failure occurs in Program Mode. Otherwise outputs will remain in ProgramMode. See ProgMode, ProgValue, FaultMode, FaultValue. 0=outputs stay in ProgramMode if comm failure 1=outputs got to FaultMode if comm failure

*Input Data Tags*

**Table A.9**  
**Diagnostic Output Module Input Data Tags**

<b>Name (as listed in the Tag Editor):</b>	<b>Configuration or I/O Data:</b>	<b>Definition:</b>
<b>CSTimestamp</b> (8 bytes)	Input data	<b>Coordinated System Time Timestamp</b> – Timestamp of diagnostic input data including fusing (see BlownFuse, NoLoad, OutputVerifyFault, FieldPwrLoss), which is updated whenever a diagnostic fault occurs or goes away.
<b>Data</b> (1 bit per point)	Input data	<b>Data</b> – Off/On status for the output point ECHOED back from the output module. This is used to verify proper communication only. No field side verification is done. For field side verification, see OutputVerifyFault. <b>0=Off, 1=On</b>
<b>Fault</b> (1 bit per point)	Input data	This is an ordered status of faults which indicates that a point is faulted and I/O data for that point may be incorrect. Check other diagnostic faults, if they are available, for further diagnosis of the root cause. If communication to the input module is lost or inhibited, then all points for the module will be faulted by the processor. <b>0=no fault, 1=fault (FuseBlown, NoLoad, OutputVerifyFault, FieldPwrLoss, or CommFault)</b>
<b>FieldPwrLoss</b> (1 bit per point)	Input Data	<b>Field Power Loss</b> – AC output diagnostic detects that field power has failed or is disconnected from the module. No Load will also be detected. <b>0=no fault, 1=fault</b>

**Table A.9**  
**Diagnostic Output Module Input Data Tags**

<b>Name (as listed in the Tag Editor):</b>	<b>Configuration or I/O Data:</b>	<b>Definition:</b>
<b>FuseBlown.</b> (1 bit per point)	Input Data	<b>Fuse is Blown</b> – An electronic or mechanical fuse has detected a short circuit condition for an output point. All FuseBlown conditions are latched and must be reset by the User. <b>0=no fault, 1=fault</b>
<b>NoLoad</b> (1 bit per group)	Input data	<b>No Load</b> – Diagnostic which indicates the absence of a load (e.g. the wire is disconnected from the module). This diagnostic only operates in the OFF state. <b>0=no fault, 1=fault</b>
<b>OutputVerifyFault</b> (1 bit per point)	Input data	<b>Output Verify</b> – Diagnostic which indicates that the output has been commanded to the ON state but the output has not been verified to be ON. <b>0=no fault, 1=fault (output is not ON)</b>

*Output Data Tag*

**Table A.10**  
**Diagnostic Output Module Output Data Tags**

<b>Name (as listed in the Tag Editor):</b>	<b>Configuration or I/O Data:</b>	<b>Definition:</b>
<b>CSTTimestamp</b> (8 bytes)	Output data	<b>Coordinated System Time Timestamp</b> – Timestamp to be used with Scheduled Outputs and Coordinated System Time (CST). Used to synchronize outputs across the system by indicating the time (CST Timestamp) at which the output module is to apply its outputs.
<b>Data</b> (1 bit per point)	Output data	Off/On status for the output point. originating from the controller <b>0=Off, 1=On</b>

## Accessing the Tags

When you access tags, you have two options. You can:

- monitor tags - option allows you to view tags and change their values
- edit tags - option allows you to add or delete tags but not change values

1. Select Controller Tags
2. Click on the right mouse button to display the menu
3. Select Monitor Tags



You can view tags here.

Click on the slot number of the module you want to see

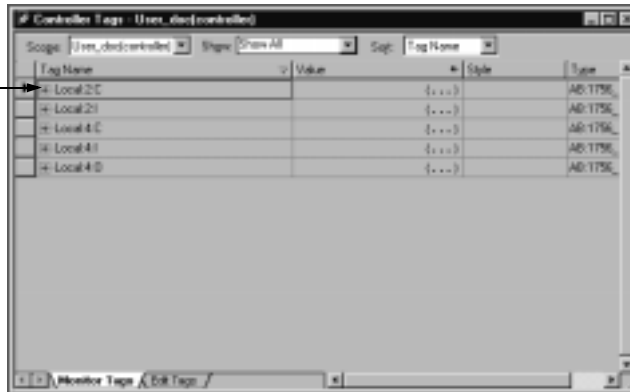

Configuration information is listed for each point on the module located at Local 2:C

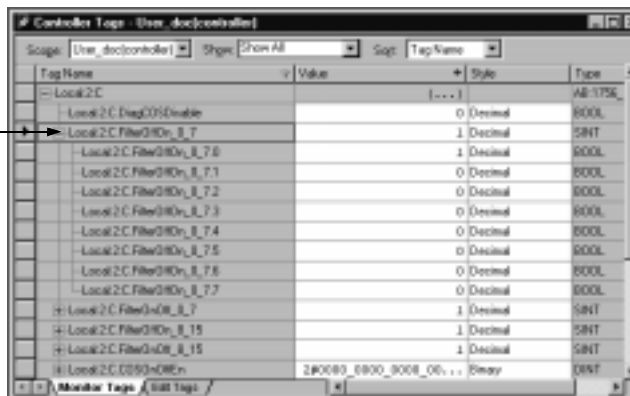

## Changing Configuration Through the Tags

Some configurable features are changed on a module-wide basis and some on a point-by-point basis.

### IMPORTANT

Although you can change the value for any point in the tags, the module's configuration is not updated until you download the information, see page A-14.

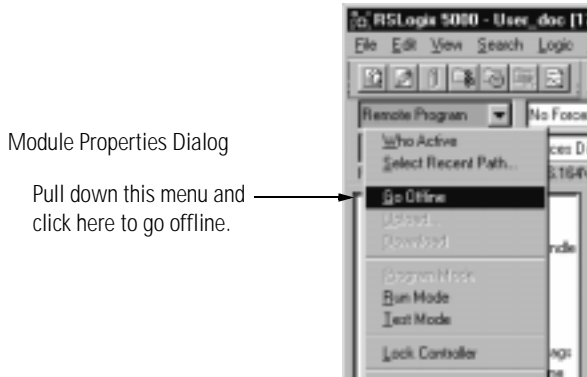

Once you are offline, you can make configuration changes.

## Module-wide Configurable Features

For features, such as Program to Fault enable, that are configured on a module-wide basis, highlight the value and type in the new value.

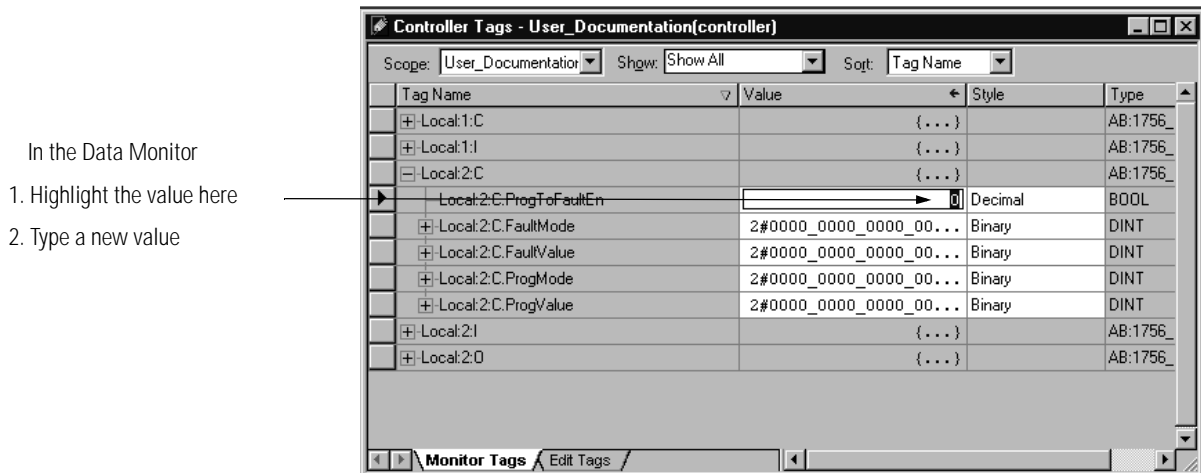

RSLogix 5000 will not allow you to enter invalid values for any feature. If you enter an invalid value, the software prompts you to reenter the value. You cannot proceed until a valid value is entered.

## Point-by-Point Configurable Features

For features, such as No Load enable, that are configured on a point-by-point basis, there are two ways to change the configuration.

- Pull-down Menu

or

- Highlight Value

### *Pull-down Menu*

1. Click on the far left side of the Value column and a pull-down menu appears

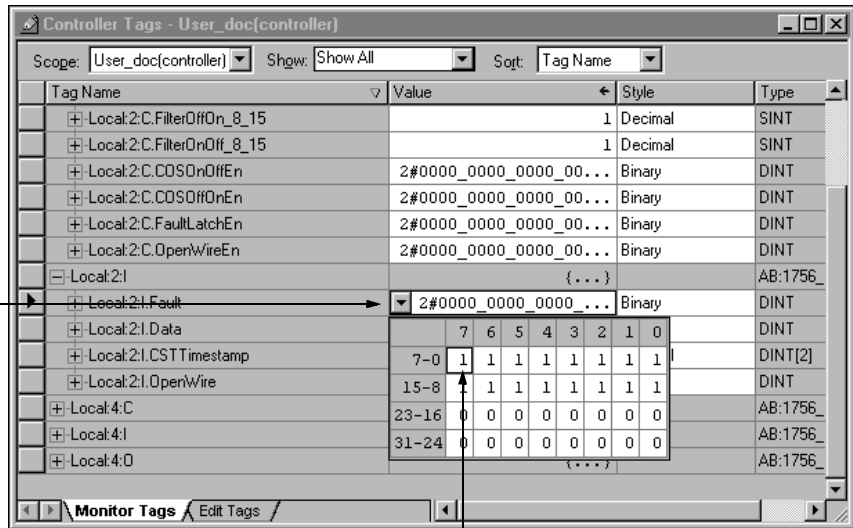

2. Highlight the point that needs to be changed and type a valid new value

NOTE: RSLogix 5000 will not allow you to enter invalid values for point-by-point features

### Highlight Value

1. Highlight the value of the feature you want to change. Note that this series of values is listed in descending order of point number. Make sure you have highlighted the point you want to change.

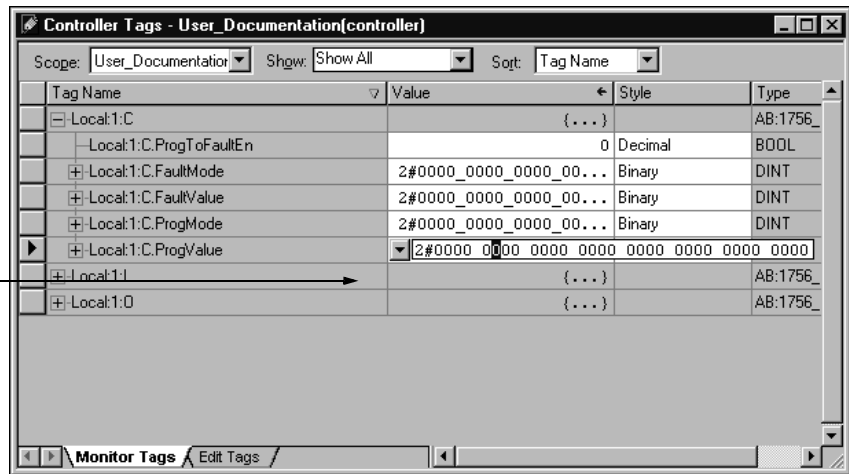

2. Type in the valid new value.

## Downloading New Configuration Data From the Tag Editor

After you change the configuration data for a module, the change does not actually take affect until you download the new information.

- Pull down this menu and click here to download the new data

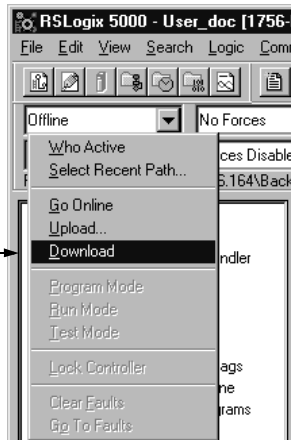

RSLogix 5000 verifies the download process with this pop-up screen.

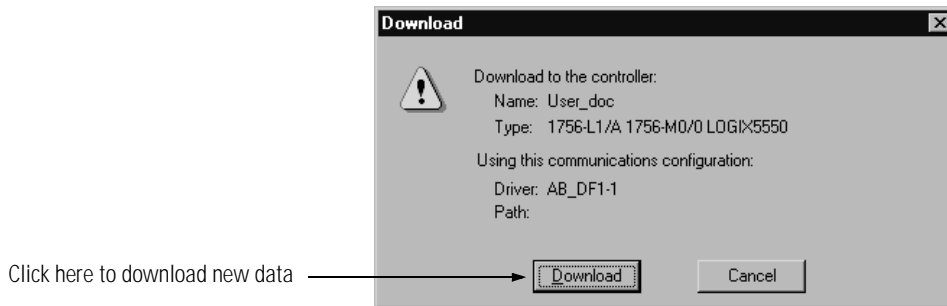

This completes the download process.

## Sample Series of Tags

### 1756-IA16I

The set of tags associated with a 1756-IA16I module that was configured using **CST Timestamped Input Data** for its Communications Format is shown below.

The configurable features for this configuration are as follows:

- Filter Times
- Change of State

When you access the tags for this module as described on page A-11, you see the screen below.

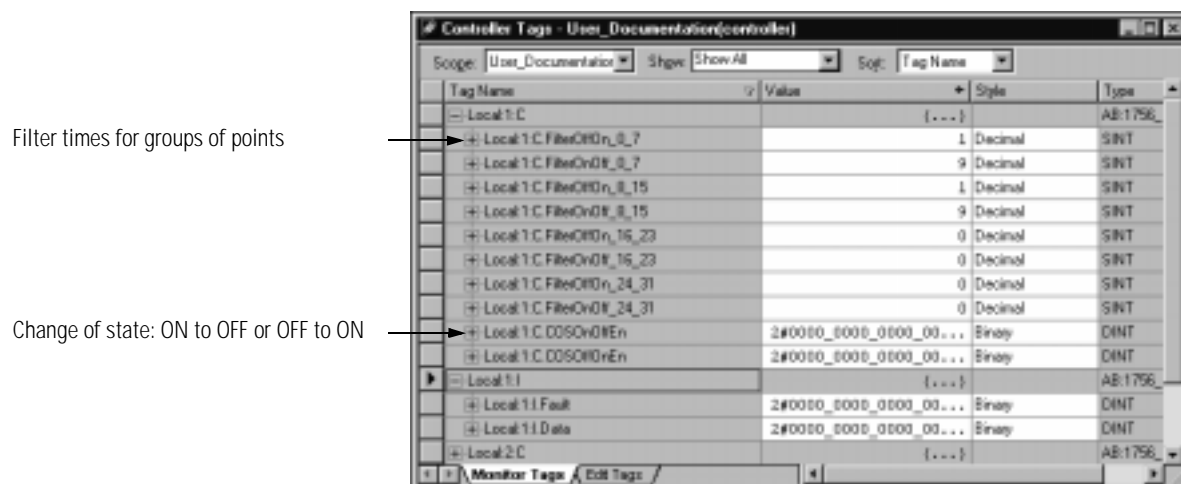

1756-OA8D

The set of tags associated with a 1756-OA8D module that was configured using **Full Diagnostics Output Data** for its Communications Format is shown below.

The configurable features for this configuration are as follows.

- Fault Mode and Value
- Program Mode and Value
- Diagnostic Latch
- No Load
- Output Verify
- Field Power Loss

When you access the tags for this module as described on page A-11, you see the screen below.

Labels on the left side of the screenshot:

- Fault mode and value
- Program mode and value
- Diagnostic latch enable
- No load enabled
- Output verify enable
- Field power loss enable

Tag Name	Value	Style	Type
Local 2.C	{...}		AB:1756
Local 2.C.ProgToFaultEn	0	Decimal	BOOL
Local 2.C.FaultMode	2#0000_0000_0000_00...	Binary	DINT
Local 2.C.FaultValue	2#0000_0000_0000_00...	Binary	DINT
Local 2.C.ProgMode	2#0000_0000_0000_00...	Binary	DINT
Local 2.C.ProgValue	2#0000_0000_0000_00...	Binary	DINT
Local 2.C.FaultLatchEn	2#0000_0000_0000_00...	Binary	DINT
Local 2.C.NoLoadEn	2#0000_0000_0000_00...	Binary	DINT
Local 2.C.OutputVerifyEn	2#0000_0000_0000_00...	Binary	DINT
Local 2.C.FieldPwrLossEn	2#0000_0000_0000_00...	Binary	DINT
Local 2.I	{...}		AB:1756
Local 2.I.Fault	2#0000_0000_0000_00...	Binary	DINT
Local 2.I.Data	2#0000_0000_0000_00...	Binary	DINT
Local 2.I.CSTTimeStamp	{...}	Decimal	DINT[2]
Local 2.I.FuseBlow	2#0000_0000_0000_00...	Binary	DINT
Local 2.I.NoLoad	2#0000_0000_0000_00...	Binary	DINT
Local 2.I.OutputVerifyFault	2#0000_0000_0000_00...	Binary	DINT
Local 2.I.FieldPwrLoss	2#0000_0000_0000_00...	Binary	DINT
Local 2.O	{...}		AB:1756
Local 2.O.Data	2#0000_0000_0000_00...	Binary	DINT

## Using Ladder Logic

You can use ladder logic to perform run time services on your module. For example, page 6-22 shows how to reset an electronic fuse on the 1756-OA8D module using RSLogix 5000. This appendix provides an example of how to reset the same fuse **without using RSLogix 5000**.

In addition to performing run time services, you can use ladder logic to change configuration. Chapter 6 explained how to use the RSLogix 5000 software to set configuration parameters in your ControlLogix analog I/O module. Some of those parameters may also be changed through ladder logic.

## Using Message Instructions

In ladder logic, you can use Message instructions to send occasional services to any ControlLogix I/O module. Message instructions send an explicit service to the module, causing specific behavior to occur, for example, unlatching a high alarm.

Message instructions maintain the following characteristics:

- messages use unscheduled portions of system communications bandwidth
- one service is performed per instruction
- performing module services does not impede module functionality, such as sampling inputs or applying new outputs

## Processing Real-Time Control and Module Services

Services sent via message instructions are not as time critical as the module behavior defined during configuration and maintained by a real-time connection. Therefore, the module processes messaging services only after the needs of the I/O connection have been met.

For example, you may want to unlatch all process alarms on the module, but real-time control of your process is still occurring using the input value from that same channel. Because the input value is critical to your application, the module prioritizes the sampling of inputs ahead of the unlatch service request.

This prioritization allows input channels to be sampled at the same frequency and the process alarms to be unlatched in the time between sampling and producing the real-time input data.

## One Service Performed Per Instruction

Message instructions will only cause a module service to be performed once per execution. For example, if a message instruction sends a service to the module to unlatch the high high alarm on a particular channel, that channel's high high alarm will unlatch, but may be set on a subsequent channel sample. The message instruction must then be reexecuted to unlatch the alarm a second time.

## Creating a New Tag

This ladder logic is written in the Main Routine section of RSLogix 5000.

Double-click here to enter the Main Routine

After adding a message instruction to a rung, you must create a tag for the message instruction

1 Right-click on the question mark (?) to see this pull-down menu.  
2 Click here to Create a Tag.

MainRoutine

Fill in the following information when the New Tag pop-up screen appears:

**IMPORTANT**

We suggest you name the tag to indicate what module service the message instruction is sending. For example, the message instruction below is used to reset an electronic fuse, and the tag is named to reflect this.

Name the tag here.

Enter an optional description here.

Choose the **Base** Tag Type here.

Choose the **Message** Data Type here.

Choose the **Controller** Scope here.

**IMPORTANT:** Message tags can only be created with the Controller Scope.

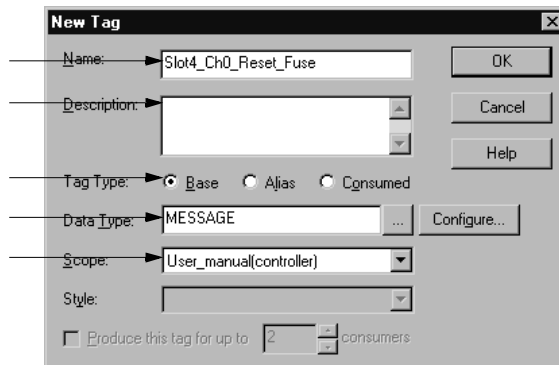

### Enter Message Configuration

After creating a new tag, you must enter message configuration.

Click here to see the message configuration pop-up screens

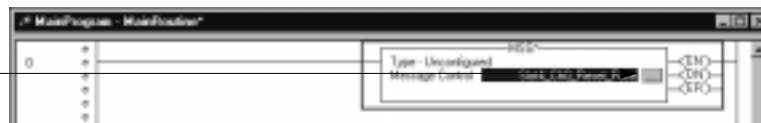

Enter message configuration on the following screens:

- Configuration pop-up screen
- Communications pop-up screen

A description of the purpose and set-up of each screen follows.

### *Configuration Pop-Up Screen*

This pop-up screen provides information on what module service to perform and where to perform it. For example, you must use this screen to reset an electronic fuse (module service) on channel 0 of a 1756-OA8D module (where to perform service).

Message Type is CIP Generic

Service Code is 4d

Object Type is 1e

Object ID is 1

Object Attribute is  
left blank

The screenshot shows the 'Message Configuration - Slot4\_Ch0\_Reset\_Fuse' dialog box. The 'Configuration' tab is selected. The fields are as follows:

- Message Type: CIP Generic
- Service Code: 4d (Hex)
- Object Type: 1e (Hex)
- Object ID: 1
- Object Attribute: (Hex)
- Source: Slot4\_Ch0\_Reset\_Fuse
- Num. Of Elements: 1 (Bytes)
- Destination: Local 4:C
- Buttons: Enable, Enable Waiting, Start, Done, Done Length: 0, Timed Out (checked), OK, Cancel, Apply, Help

Table B.2 contains information that must be entered on the configuration pop-up screen to perform I/O module services:

**Table B.1  
Module Services and Configuration Pop-Up Screen Information**

Service:	Description:	Service Code	Object Type	Object ID	Object Attribute	Source	Number of Elements (bytes)	Destination:	Modules:
Retrieve CST information	Obtain module's CST status and check if module is synchronized with the CST.	1	77	1	N/A	N/A	0	CST_Information SINT [20]	All
Retrieve Device Information (WHO)	Obtain module's general status such as ownership, health and identity.	1	1	1	N/A	N/A	0	WHO_Information SINT[48]	All
Reset the Module	Reset module to "out of the box condition" and go through a power-up.	5	1	1	N/A	N/A	0	N/A	All
Reset Latched Diagnostic	Clear any latched faults except Fuse Blown	4b	1d = input modules 1e = output modules	1	N/A	Enable_32_Points DINT	4	N/A	1756-OA8 D, OB16D, OA8E, IA8D, IB16D only
Reset Electronic Fuse	Reset blown fuse status for a point	4d	1e = output module	1	N/A	Enable_32_Points DINT	4	Results_32_Points DINT	1756-OA8 D, OB16D
Pulse Test	Performs a pulse test on the point. Only test one point at a time.	4c	1e = output module	1	N/A	Pulse_Test_Parameters SINT[10]	10	N/A	1756-OA8 D, OB16D

Some services require multiple parameters/tags in the source and destination fields (e.g. Pulse Test).

These services use copy instructions to move the multiple tags to/from the message instruction source/destination tags. Table 2 lists the copy instruction parameters need for these services.

**Table B.2**  
**Copy Instruction Parameters for Module Services**

Source/Destination Tag in MSG Instruction:	Description:	Copy Instruction (COP) - This instruction moves data to/from generic source/destination buffers		
		Source	Destination	Length (bytes)
Pulse_Test_Parameters SINT[10]	Determines which point to perform the pulse test on. Each bit corresponds to a point. Only test one point at a time.	Enable_32_points DINT	Pulse_Test_Parameters [0]	4
	Determines maximum pulse width of the pulse test in ms. Pulse test inverts state of the output up to the maximum specified time. Units are in 100µs increments. Default tag value = 2ms (i.e. 20).	Pulse_Width INT	Pulse_Test_Parameters[ 4]	2
	For AC modules only, this specifies how long to delay after the zero cross before performing the pulse test. Optimum time to perform pulse test is at its peak AC voltage. Units are in 100µs increments. Default tag value = 4ms (i.e. 40).	Zero_Cross_Delay INT	Pulse_Test_Parameters[ 6]	2
	Specifies how long to wait after the pulse is completed before declaring a fault. Output verify delay parameter is needed to account for the hardware propagation delay. Units are in 100µs increments. Default tag value = 2ms (i.e. 20).	Output_Verify_Delay INT	Pulse_Test_Parameters[ 8]	2
CST_Information SINT[20]	Current CST Time from Module	CST_Information[0]	Current_Time DINT[2]	8
	Status of CST in Module Bit0: 0=timer OK, 1=timer fault Bit1: 0=no ramping, 1=ramping (ramping indicates that once time is synchronized, it will correct errors by slowly ramping to the master's time) Bit2: 0=not time master, 1=time master (e.g. controller) Bit3: 0=time not synced, 1=time synced with master	CST_Information[8]	CST_Status INT	2
	Size of timer in bits	CST_Information[10]	CST_Timer_Size INT	2
	Unused	CST_Information[12]	CST_reserved	8

**Table B.2**  
**Copy Instruction Parameters for Module Services**

Source/Destination Tag in MSG Instruction:	Description:	Copy Instruction (COP) - This instruction moves data to/from generic source/destination buffers		
		Source	Destination	Length (bytes)
WHO_Information SINT[47]	Device manufacturer's vendor ID (e.g. 1=AB)	WHO_Information[0]	WHO_vendor INT	2
	Device's product type (e.g. 7=Digital I/O)	WHO_Information[2]	WHO_product_type INT	2
	Device's catalog code which maps to its catalog number	WHO_Information[4]	WHO_catalog_code INT	2
	Device's major revision	WHO_Information[6]	WHO_major_revision SINT	1
	Device's minor revision	WHO_Information[7]	WHO_minor_revision SINT	1
	Device's internal status Bit0: 0=unowned, 1=owned Bit2: 0=unconfigured, 1=configured Bits7-4: forms a 4-bit number indicating Device Specific Status For Digital I/O: 0 = Self-Test 1 = Flash update in progress 2 = Communications fault 3 = Not owned 4 = Unused 5 = Internal fault (module needs to be flash updated) 6 = Run Mode 7 = Program Mode (N/A for input modules) Bit8: 0=no fault, 1=Minor recoverable fault (e.g. backplane error detected) Bit9: 0=no fault, 1=Minor non-recoverable fault Bit10: 0=no fault, 1=Major recoverable fault Bit11: 0=no fault, 1=Major non-recoverable fault (e.g. module needs to be reflashed) Bits15-12: unused	WHO_Information[8]	WHO_status INT	2
	Device's serial number	WHO_Information[10]	WHO_serial_number DINT	4
	Number of characters in the text string.	WHO_Information[14]	WHO_string_length SINT	1
	Device's ASCII text string describing the module.	WHO_Information[15]	WHO_ascii_string	32

Table 3 lists tags used in the Source and Destination fields of the Message Instructions.

**Table B.3**  
**Source and Destination Field Tags**

Source Tag:	Description:
Enable_32_Points DINT	Parameter used to determine which points are enabled for the service e.g. If bit 0 = 1 for Reset Fuse, then point 0 has its electronic fuse reset.
Results_32_Points DINT	Pass (0)/ Fail (1) result for the service i.e. If bit 0 = 1 for the results of the Reset Fuse, then the Reset Fuse failed for point 0.

### *Communications Pop-Up Screen*

This pop-up screen provides information on the path of the message instruction. For example, the slot number of a 1756-OA8D module distinguishes exactly which module a message is designated for.

#### **IMPORTANT**

Use the Browse button to see a list of the I/O modules in the system. You choose a path when you choose a module from the list.

You must name an I/O module during initial module configuration to choose a path for your message instruction.

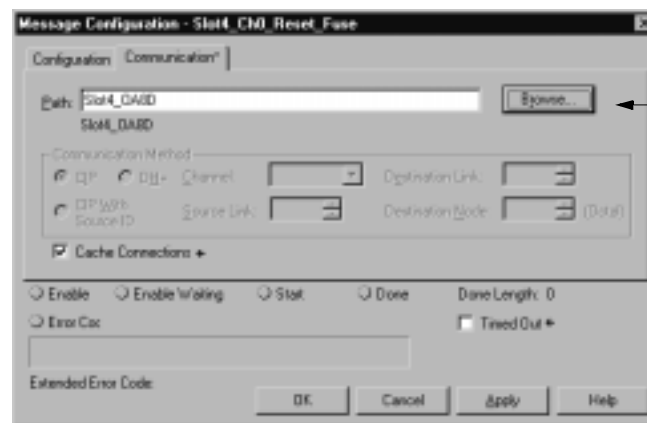

Use this Browse button to see a list such as the one displayed below.



## Using Timestamped Inputs and Scheduled Outputs

This example demonstrates the use of timestamped inputs and scheduled outputs for digital I/O. The CST can be utilized to synchronize the output turning OFF to ON based upon the time that the input transitioned OFF to ON. The program can be extended to include synchronizing multiple output modules by sending the same timestamp to all output modules.

For this example, the output will follow the state of the input 0, but it will be delayed by exactly 10ms. The advantage of using CST (over timers) is that the synchronization is being performed at the I/O module which eliminates any jitter due to controller or communication delays.

Your control becomes much more deterministic even under changing loads. For this synchronization to work properly, the 10ms delay must be long enough to account for any controller, backplane, and network delays. The input and output modules must reside in the same rack as a Time Master (i.e. Controller) Timestamp units are  $\mu$ secs.

Rungs 0 and 1 are used to detect the transition from PROGRAM to RUN mode. This is used to turn ON "init" which causes the program to initialize its tags

Rung 2 only executes once and initializes the LastTimestamp. LastTimestamp is used to detect a Change of State on the input point by checking to see if the timestamp of the input data has changed

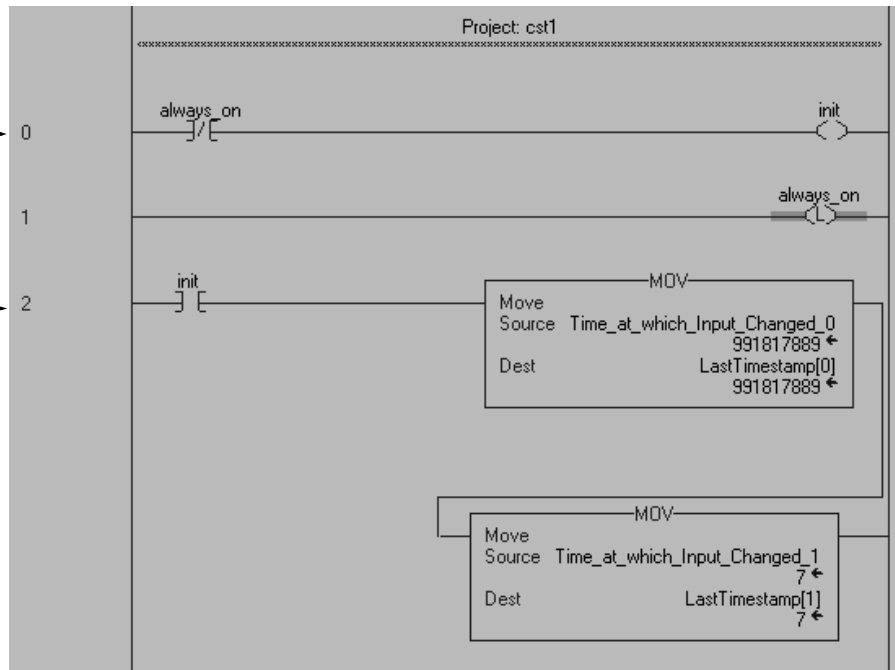

Rung 3 is the main rung which checks for Change of State on the input point by comparing the current input timestamp (i.e. Time\_at\_which\_Input\_Changed) with the last timestamp (i.e. LastTimestamp).

The input point (i.e. point 0) must have Change of State enabled or the timestamp will not update when the point transitions (e.g. OFF-ON). Once Change of State has been detected, 10ms is ADDED to the input timestamp and sent to the output module's timestamp.

This will cause the output module to apply its output exactly 10ms (i.e. 10,000 $\mu$ s) after the input changed state.

The MOVE instructions update "LastTimestamp[]" in preparation for the next change of state.

### IMPORTANT

Timestamps are 8 bytes in size, two DINTs, but only the lower 4 bytes of the output timestamp (i.e. Time\_at\_which\_Output\_Will\_Change) are used to schedule the outputs into the future (to a max of 16.7s or 16,700,000 $\mu$ s)

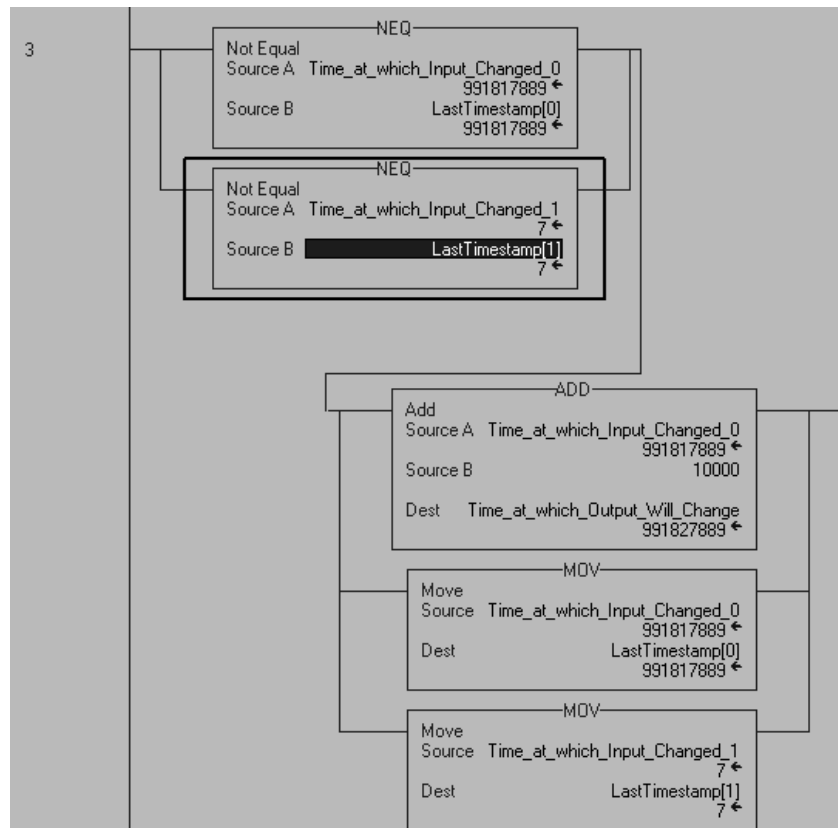

Rung 4 is the standard XIC-OTE rung which controls the output point based upon the input point.

The only difference is that the output module is configured for Scheduled Outputs. The outputs will not get applied until the scheduled time has occurred.



The following screen shows examples of the tags used in the ladder logic as they appear in the tag editor.

These tags were created for this ladder logic.

P	Tag Name	Alias For	Base Tag	Type	Style	Description
	always_on			BOOL	Decim	
	init			BOOL	Decim	
	[-] LastTimestamp			DINT[2]	Decim	
	[-] LastTimestamp[0]			DINT	Decim	
	[-] LastTimestamp[1]			DINT	Decim	
	[+] Local:0:C			AB:175		
	[+] Local:0:I			AB:175		
	[+] Local:1:C			AB:175		
	[+] Local:1:I			AB:175		
	[+] Local:1:O			AB:175		
	[ ] Time_at_which_Input_Changed_0	Local:0:I.CSTTimestamp[0]	Local:0:I.C	DINT	Decim	
	[ ] Time_at_which_Input_Changed_1	Local:0:I.CSTTimestamp[1]	Local:0:I.C	DINT	Decim	
	[ ] Time_at_which_Output_Will_Change	Local:1:O.CSTTimestamp[0]	Local:1:O	DINT	Decim	

## Resetting a Fuse, Performing the Pulse Test and Resetting Latched Diagnostics

### IMPORTANT

Version 8 of the RSLogix CD contains a sample program for the Pulse Test.

The following ladder logic program shows how to reset the electronic fuse of a faulted point and perform a pulse test through ladder logic.

Rungs 0 and 1 are used to perform a reset fuse service on Bits 0 and 1, respectively, of a 1756-OA8D module in slot 4.

Rung 2 performs a pulse test service to slot 4.

Rung 3 moves the results of the pulse test to a data storage location. (The actual results appear in the message instruction tags under the tag name EXERR)

Rung 4 performs a reset latched diagnostics service to slot 4. This example shows an output module.

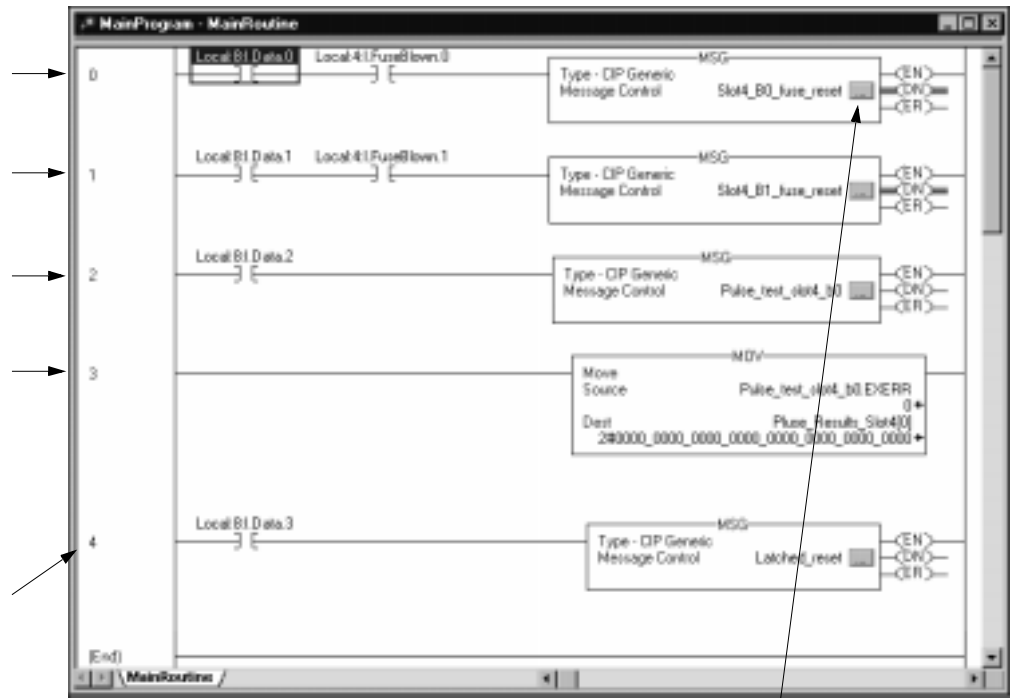

Click on the box in each rung to see the configuration and communication information pop-up associated with it. Examples of these pop-ups can be found on the following pages

The following screen shows examples of the tags used in the ladder logic as they appear in the tag editor.

These tags were created for this ladder logic.

#	Tag Name	Alias For	Base Tag	Type	Style	Description
1	Slot4_B0_fuse_reset			MESSAGE		
2	Slot4_B1_fuse_reset			MESSAGE		
3	reset_slot4_30			DINT	Binary	
4	reset_slot4_30			DINT	Decimal	
5	Pulse_test_slot4_30			MESSAGE		
6	pulse_slot4_30			DINT[R]	Binary	
7	pulse_results_slot4			DINT[F]	Decimal	
8	Pulse_Results_Slot4			DINT[F]	Binary	
9	Local:9I			AB:1756_DI_DC_...		
10	Local:9C			AB:1756_DI_DC_...		
11	Local:9I			AB:1756_DI_Time...		
12	Local:9C			AB:1756_DI_C:0		
13	Local:7D			AB:1756_DO:0 B		

## Performing a WHO to Retrieve Module Identification and Status

This ladder logic example shows how to retrieve module identification and status through a WHO service. In this application, a message instruction retrieves the following module identification information:

- Product type
- Product code
- Major revision
- Minor revision
- Status
- Vendor
- Serial number
- String length
- Ascii string

A full explanation of each module identification category above is provided after the ladder logic application.

**IMPORTANT**

This example uses a user-defined WHO data structure and a series of Copy instructions (following the Message instruction in the screen capture below) to make the module identification information more easily understood.

The user-defined data structure appears below.

The user-defined WHO data structure displays module identification information in an easily understood format.

For example, major revision displays that the module's major revision is 2.

Tag Name	Value	Force Mask	Style	Type	De
Local 3:C	(...)	(...)		AB:1756_DIC:0	
Local 3:I	(...)	(...)		AB:1756_DI:0	
WHO	(...)	(...)		WHO_Information...	
WHO_vendor	16#1001		Hex	INT	
WHO_product_type	7		Decimal	INT	
WHO_product_code	2		Decimal	INT	
WHO_major_revision	2		Decimal	SINT	
WHO_minor_revision	5		Decimal	SINT	
WHO_status	2#0300_0000		Binary	INT	
WHO_serial_number	16#e000_3ba2		Hex	DINT	
WHO_string_length	32		Decimal	SINT	
WHO_ascii_string	(...)	(...)	Hex	SINT[32]	
WHO_information	(...)	(...)	Hex	SINT[48]	
who_msg	(...)	(...)		MESSAGE	

You do not have to create the user-defined data structure. If you choose not to create this structure, you can use the Ascii string and String length to retrieve and understand module identification through some interface excluding RSLogix 5000 software.

The screen below shows the example WHO ladder logic application.

**Rung 0** constantly polls the module for WHO status. To conserve bandwidth, only poll for status when necessary.

**Rung 1** extracts the product type and catalog code.

**Rung 2** extracts the module's major and minor revisions.

**Rung 3** extracts the module's status information.

**Rung 4** extracts the vendor ID and serial number.

**Rung 5** extracts the module's ASCII text string and the length of the text string in bytes.

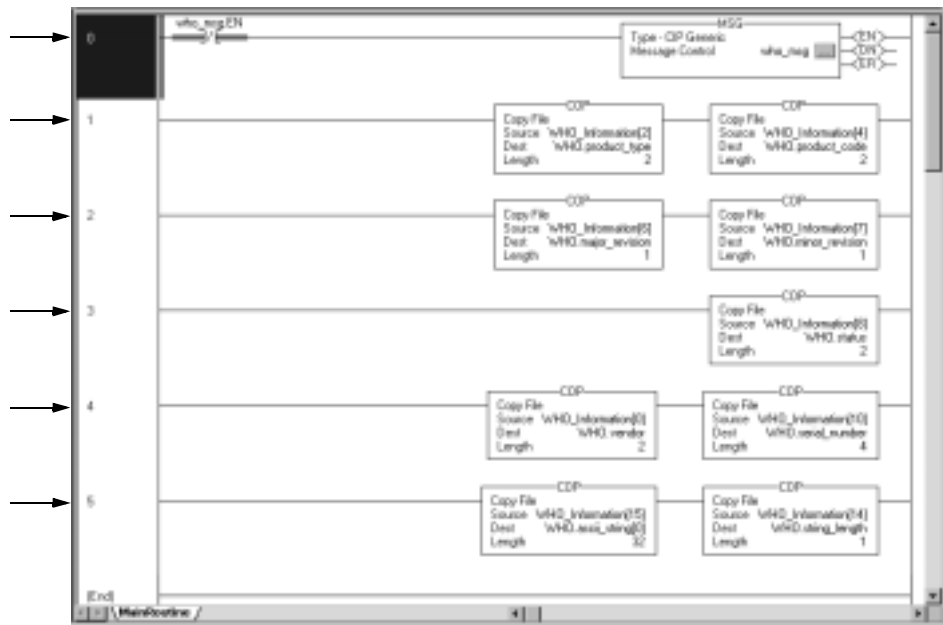

Use Table 4 to understand the values returned for each rung.

**Table B.4**  
Rung Values for Example WHO Ladder Logic Application

Rung:	Destination (Module Identification Retrieved):	Description:
Rung 1	Product Type Catalog Code	Module's product type, 7 = Digital I/O 10 = Analog I/O Module's catalog number.
Rung 2	Major Revision Minor Revision	Module's major revision Module's minor revision

**Table B.4**  
**Rung Values for Example WHO Ladder Logic Application**

Rung:	Destination (Module Identification Retrieved):	Description:
Rung 3	Status	Module's status. Multiple bits listed. Bit 0: 0 = Unowned, 1 = Owned Bit 1: Reserved Bit 2: 0 = Unconfigured, 1 = Configured Bit 3: Reserved Bits 7-4: Forms a 4-bit number indicating Device Specific Status. 0 = Self-Test 1 = Flash update in progress 2 = Communications fault 3 = Not owned (outputs in prog. mode) 4 = unused 5 = Internal fault (need flash update) 6 = Run mode 7 = Program mode (output mods only) Bit 8: 0 = No fault, 1 = Minor recoverable fault Bit 9: 0 = No fault, 1 = Minor unrecoverable fault Bit 10: 0 = No fault, 1 = Major recoverable fault Bit 11: 0 = No fault, 1 = Major unrecoverable fault Bits 15-12: Unused
Rung 4	Vendor ID Serial Number	Module manufacturer vendor, 1 = Allen-Bradley Module serial number
Rung 5	Length of ASCII Text String ASCII Text String	Number of characters in module's text string Module's ASCII text string description

## Using Tags in Ladder Logic

When using tags in ControlLogix digital I/O ladder logic applications, you must remember the following:

- Ladder logic tags represent the module on a **point per bit basis**. For example, point 0 = bit 0 on the module
- If you are **performing a service** through the tags, a value of 0 prevents the action from occurring, and a value of 1 causes the action to occur. For example, if you want to reset the electronic fuse on a particular bit, enter 1 in the tags.
- If you are checking the **response of a service** through the tags, a value of 0 means the bit passed the service, and a value of 1 means the bit failed the service. For example, if you perform a pulse test and the response displays a 0 for a particular bit, the bit passed the test.

## Power Supply Sizing Chart

Use the following chart to check the power your ControlLogix chassis is using.

Table C.1  
Power Supply Sizing Chart

Slot Number	Module Catalog Number	Current @ 5.1V DC (mA)		Power @ 5.1V DC (Watts)	Current @ 24 VDC (mA)		Power @ 24 VDC (Watts)	Current @ 3.3V DC (mA)		Power @ 3.3V DC (Watts)			
0			x 5.1V =			x 24V =			x 3.3V =				
1			x 5.1V =			x 24V =			x 3.3V =				
2			x 5.1V =			x 24V =			x 3.3V =				
3			x 5.1V =			x 24V =			x 3.3V =				
4			x 5.1V =			x 24V =			x 3.3V =				
5			x 5.1V =			x 24V =			x 3.3V =				
6			x 5.1V =			x 24V =			x 3.3V =				
7			x 5.1V =			x 24V =			x 3.3V =				
8			x 5.1V =			x 24V =			x 3.3V =				
9			x 5.1V =			x 24V =			x 3.3V =				
10			x 5.1V =			x 24V =			x 3.3V =				
11			x 5.1V =			x 24V =			x 3.3V =				
12			x 5.1V =			x 24V =			x 3.3V =				
13			x 5.1V =			x 24V =			x 3.3V =				
14			x 5.1V =			x 24V =			x 3.3V =				
15			x 5.1V =			x 24V =			x 3.3V =				
16			x 5.1V =			x 24V =			x 3.3V =				
	TOTALS		mA		W (1)		mA		W (2)		mA		W (3)
		This number cannot exceed:				This number cannot exceed 2800mA			This number cannot exceed 4000mA				
		<ul style="list-style-type: none"> <li>10000mA for 1756-PA72/PB72</li> <li>13000mA for 1756-PA75/PB75</li> </ul>			These three wattage values (1, 2, 3), added together, cannot exceed: <ul style="list-style-type: none"> <li>70W @ 40°C - For 1756-PA72/PB72, Series A 55W @ 60°C - For 1756-PA72/PB72, Series A</li> <li>75W @ 40°/60°C - For 1756-PA72/PB72, Series B and 1756-PA75/PB75, Series A</li> </ul>								

We recommend that you copy this worksheet for use in checking the power supply of each ControlLogix chassis used.

**Notes:**

## Driving Motor Starters with ControlLogix Digital I/O Modules

Use this appendix to choose a ControlLogix digital I/O module to drive Bulletin 500 Series motor starters in your application. The tables below list the number of motor starters (5 sizes are listed for each module) that a particular digital I/O module can drive.

**IMPORTANT**

When using the tables, remember that the supply voltage for each module must not drop below the minimum state motor starter supply voltage.

**Table D.1**  
Maximum Allowed 2-3 Pole Motor Starters (120V ac/60Hz)

Catalog Number	Size 0-1 Motor Starter	Size 2 Motor Starter	Size 3 Motor Starter	Size 4 Motor Starter	Size 5 Motor Starter
1756-OA16I	16	15 @ 30°C 12 @ 60°C	13 @ 30°C 10 @ 60°C	8 @ 30°C 6 @ 60°C	5 @ 30°C 4 @ 60°C
1756-OA16	16	14 (Only 7 per group)	4 (Only 2 per group)	None	None
1756-OA8	8	8	8	8 @ 30°C 6 @ 60°C	5 @ 30°C 4 @ 60°C
1756-OA8D	8	8	8	None	None
1756-OA8E	8	8	8	6 (Only 3 per group)	6 @ 30°C (Only 3 per group) 4 @ 60°C (Only 2 per group)

**Table D.2**  
**Maximum Allowed 2-3 Pole Motor Starters (230V ac/60Hz)**

Catalog Number	Size 0-1 Motor Starter	Size 2 Motor Starter	Size 3 Motor Starter	Size 4 Motor Starter	Size 5 Motor Starter
1756-OA16I	16	16	16	16 @ 30°C 13 @ 60°C	11 @ 30°C 9 @ 60°C
1756-OA16	16	16	16	4 (Only 2 per group)	2 (Only 1 per group)
1756-OA8	8	8	8	8	8

**Table D.3**  
**Maximum Allowed 2-3 Pole Motor Starter (24V ac/60Hz)**

Catalog Number	Size 0-1 Motor Starter	Size 2 Motor Starter	Size 3 Motor Starter	Size 4 Motor Starter	Size 5 Motor Starter
1756-ON8	4 @ 30°C 3 @ 60°C	4 @ 30°C 3 @ 60°C	None	None	None

## Determining the Maximum Number of Motor Starters

To determine the maximum number of motor starters that can be used by a particular 1756 catalog number refer to the following example:

1. Choose your motor starter:

Allen-Bradley Bulletin 500 Size 3 120V ac/60Hz/ 2-3 Poles,  
 Inrush 1225VA, Sealed=45VA

2. Determine the number of Motor starters required for your application:

12 size 3 motor starters

**3.** Choose a ControlLogix digital output module:1756-OA16I/A**Output voltage** = 74 – 265V ac**Output steady state current per point** = 2A maximum @ 30°C  
& 1A maximum @ 60°C (Linear derating)**Output steady state current per module** = 5A maximum @  
30°C

&amp; 4A maximum @ 60°C (Linear derating)

**Output surge current per point** = 20A maximum for  
43mS repeatable every 2S @ 60°C**4.** Determine the maximum environmental operating temperature:

50°C

**5.** Confirm the voltage Range is within the Motor starter range:

Motor Starter uses 120V ac

1756-OA16I/A operates in a 74 – 120V ac voltage range

**6.** Confirm the inrush current per point:Inrush of motor starter – Line voltage = Inrush current = 1225VA/  
120V ac = 10.2Amps InrushThe 1756-OA16I allows 20A Inrush current from above  
specification at @ 60°C**7.** Confirm the steady state point current of the module can drive  
the motor starter:Sealed/Line voltage = Steady state current = 45VA/120V ac  
= 0.375A @ 50°COutput point current can drive: 2A - (.033mA X 10°C)  
= 2A - 0.33A = 1.67A @ 50°C

Above 30°C, output point derates to .033mA/°C (point derating)

The 1756-OA16I/A output point current (1.67A) can drive the  
motor starter (0.375A) @ 50°C

- 8.** Confirm the 1756-OA16I/A total module current can drive 12 size 3 motor starters @ 50°C:

$$\begin{aligned} \text{Motor starter steady state current X 11 motor starters} &= .375 \times 12 \\ &= 4.5\text{A @ } 50^\circ\text{C} \end{aligned}$$

$$\begin{aligned} \text{The output total module current can drive: } &5\text{A} - (.033\text{mA} \times \\ &10^\circ\text{C}) = 5\text{A} - 0.33\text{A} = 4.67\text{A @ } 50^\circ\text{C} \end{aligned}$$

Above 30°C total output current derates to .033mA/°C  
(Module derating)

The 1756-OA16I/A total output current (4.67A) can drive the 12 motor starters (4.5A) @ 50°C

## Numerics

**1756-IA16**  
Module-specific information 7-2

**1756-IA16I**  
Module-specific information 7-4

**1756-IA8D**  
Module-specific information 7-6

**1756-IB16**  
Module-specific information 7-8

**1756-IB16D**  
Module-specific information 7-10

**1756-IB16I**  
Module-specific information 7-12

**1756-IB32**  
Module-specific information 7-14

**1756-IC16**  
Module-specific information 7-16

**1756-IH16I**  
Module-specific information 7-18

**1756-IM16I**  
Module-specific information 7-20

**1756-IN16**  
Module-specific information 7-22

**1756-IV16**  
Module-specific information 7-24

**1756-IV32**  
Module-specific information 7-26

**1756-OA16**  
Module-specific information 7-28

**1756-OA16I**  
Module-specific information 7-30

**1756-OA8**  
Module-specific information 7-32

**1756-OA8D**  
Module-specific information 7-34

**1756-OA8E**  
Module-specific information 7-36

**1756-OB16D**  
Module-specific information 7-38

**1756-OB16E**  
Module-specific information 7-40

**1756-OB16I**  
Module-specific information 7-42

**1756-OB32**  
Module-specific information 7-44

**1756-OB8**  
Module-specific information 7-46

**1756-OB8EI**  
Module-specific information 7-48

**1756-OC8**  
Module-specific information 7-50

**1756-OH8I**  
Module-specific information 7-52

**1756-ON8**  
Module-specific information 7-54

**1756-OV16E**  
Module-specific information 7-56

**1756-OW16I**  
Module-specific information 7-58

**1756-OX8I**  
Module-specific information 7-60

## A

**Accessing Module Tags** A-11

**Agency Certification**

Class I Division 2, UL, CSA, FM and CE 1-1, 3-10, 3-11,  
4-10, 4-11

## B

**Bidirectional Connections** 2-6, 2-8

## C

**Cage Clamp RTB** 5-4

**CE Certification** 1-1, 3-11, 4-11

**Change of State**

Diagnostic change of state 4-16

**Change of State (COS)** P-2, 2-10, 3-11, 4-14, 4-16,  
6-12, A-2

Diagnostic modules 4-16, 4-25

**Class I Division 2 Certification** 1-1, 3-10, 4-10

**Communications**

Producer/consumer model 2-9, 2-14

**Communications Format** P-2, 6-3, 6-6

Choosing in RSLogix 5000 6-5, 6-7

CST timestamped fuse data - output data 6-7

CST timestamped fuse data - scheduled output data 6-8

CST timestamped input data 6-6

Full diagnostic - output data 6-7

Full diagnostic input data 6-6

Full diagnostics - scheduled output data 6-8

Input module formats 6-6

Listen-only 6-6, 6-8

Listing for all I/O modules 6-9

Output module formats 6-7

Rack optimization P-3, 6-6, 6-8

Scheduled output data 6-7

Usage tip 6-6

**Compatible Match**

Electronic keying 3-5, 4-5

**Configuration**

Accessing module tags 6-23, A-11  
Altering the default configuration 6-10  
Changing through module tags A-12  
Configuring a diagnostic input module 6-14  
Configuring a diagnostic output module 6-15  
Configuring a nondiagnostic input module 6-12  
Configuring a nondiagnostic output module 6-13  
Configuring modules in remote chassis 6-19  
Creating a new module 6-4  
Downloading new data A-14  
Downloading new data from the tag editor A-14  
Dynamic reconfiguration 6-16  
Editing configuration in RSLogix 5000 6-16  
Local vs. remote chassis 6-2  
Message configuration with ladder logic B-4  
Overview of the process 6-2  
Reconfiguring in program mode 6-18  
Reconfiguring in remote run mode 6-17  
Using module tags A-3, A-4, A-6, A-8  
Using RSLogix 5000 6-2  
Using the default configuration 6-10

**Configuring a ControlLogix System**

Using RSLogix 5000 2-2  
Using RSNetWorx 2-2

**Connections P-2, 2-6**

Connector pins on the module 1-4  
ControlBus P-2, 1-4  
Differences between direct and rack connections 2-9  
Direct connection P-2, 2-6  
Listen-only connection P-2  
Listen-only rack optimization 2-7  
Number allowed 2-6, 2-7, 2-8  
Rack connection 2-7  
Rack optimization 2-7, 2-8, 6-6

**ControlBus Connector P-2, 1-4****Controller**

Logix5550 Controller P-1, 2-2

**ControlNet**

Direct connections 2-6  
Input modules in remote chassis 2-11  
Network Update Time (NUT) P-3  
Output modules in remote chassis 2-15  
Rack connection P-3, 2-7  
Rack optimization P-3, 2-7  
Tip on conserving bandwidth 2-11

**Coordinated System Time (CST) P-2**

CSA Certification 1-1, 3-11, 4-11

**CST Timestamped Fuse Data - Output Data  
Communications Format 6-7****CST Timestamped Fuse Data - Scheduled Output Data  
Communications Format 6-8****CST Timestamped Input Data Communications Format  
6-6****D****Data Exchange**

Producer/consumer model 1-1, 2-9, 2-14, 3-9, 4-9

**Data Transmissions**

Adjusting the RPI 6-18  
Choosing an input module communications format 6-6  
Choosing an output module communications format 6-7  
COS 2-10, 3-11, 4-14, 4-16  
Diagnostic change of state 4-16  
Diagnostic output modules 4-25  
RPI P-3, 2-10, 3-11, 4-14, 4-16, 4-25  
Using COS on nondiagnostic input modules 6-12  
Using timestamped inputs and scheduled outputs B-10

**Default Configuration 6-10****Diagnostic Change of State 4-16, 4-25****Diagnostic Latching 3-17, 4-11****Diagnostic Timestamp 4-11****Direct Connection P-2, 2-6****Disable Keying**

Electronic keying 3-6, 4-6

**Downloading Configuration Data**

From the tag editor A-14

**Dynamic Reconfiguration 6-16****E****Electronic Keying P-2, 3-4, 4-4, 6-9**

Choosing in RSLogix 5000 6-5, 6-9  
Compatible match P-2, 3-5, 4-5  
Disable keying P-2, 3-6, 4-6  
Exact match P-2, 3-4, 4-4  
Usage tip 3-5, 4-5

**Electrostatic Discharge**

Preventing 1-6

**Exact Match**

Electronic keying 3-4, 4-4

**Extended-Depth Housing**

Cabinet-size considerations 5-9  
Using 5-8, 5-9

**F****Fault Reporting**

- Determining fault type with RSLogix 5000 8-5
- Diagnostic input modules 4-25
- Diagnostic modules 4-3, 4-12
- Diagnostic output modules 4-17, 4-27
- Standard input modules 3-18
- Standard modules 3-3
- Standard output modules 3-19

**Field Power Loss Detection**

- 1756-IA8D module 4-16
- 1756-OA8E module 3-17

**Field Power Loss Word**

- Diagnostic input modules 4-25, 4-26
- Diagnostic output modules 4-27, 4-28
- Standard output modules 3-19, 3-20

**Filter Times**

- Software configurable 3-11, 4-14

**FM Certification** 1-1, 3-11, 4-11**Full Diagnostic - Output Data Communications Format** 6-7**Full Diagnostic Input Data Communications Format** 6-6**Full Diagnostics - Scheduled Output Data Communications Format** 6-8**Fuse Blown Word**

- Diagnostic output modules 4-27, 4-28
- Standard output modules 3-19, 3-20

**Fusing**

- Diagnostic output modules 4-20, 4-24
- Nondiagnostic output modules 3-14
- Recommended fuses for diagnostic output modules 4-20
- Recommended fuses for standard output modules 3-15
- Resetting a fuse in ladder logic B-13
- Resetting electronic fuse in RSLogix 5000 6-22

**H****Housing**

- Choosing the extended-depth housing 5-8

**I****Inhibit**

- Choosing in RSLogix 5000 6-10
- Preventing communication P-2

**Input Module Filters**

- Configuring in RSLogix 5000 3-11, 4-14, 6-12, 6-14

**Input Online Services** 6-21**Installing the ControlLogix I/O Module** 5-1**Interface Module (IFM)** P-2, 1-2**Internal Module Operations** 2-4**J****Jumper Bar** 5-5

- Using with 1756-IA16I module 7-4
- Using with the 1756-IB16I module 7-12
- Using with the 1756-IH16I module 7-18
- Using with the 1756-IM16I module 7-20
- Using with the 1756-OA16I module 7-30
- Using with the 1756-OB16I module 7-42
- Using with the 1756-OW16I module 7-58
- Using with the 1756-OX8I module 7-60

**K****Keying** 5-2

- Electronic 3-4, 4-4
- Mechanical keying 1-4

**L****Ladder Logic**

- Creating new tag B-3
- Message configuration B-4
- message instruction B-3
- Message instructions B-1
- Message number of elements B-6
- Message object attributes B-6
- Message object ID B-6
- Message object types B-6
- Message service codes B-6
- Module services B-2
- Performing the pulse test B-13
- Resetting a fuse B-13
- Resetting latched diagnostics B-13

**Latched Diagnostics**

- resetting with ladder logic B-13

**Latching**

- Diagnostic latching 3-17, 4-11

**Leakage Resistor**

- Determining on 1756-IA8D module 7-6
- Determining on 1756-IB16D module 7-10

**LED Status Indicators** 3-10, 4-10

- Input modules 8-1
- Output modules 8-2

**Listen-Only Communications Formats**

- Input modules 6-6
- Output modules 6-8

**Listen-Only Connections** P-2, 2-17**Listen-Only Rack Connection** 2-7**Listen-Only Rack Optimization** 2-7

**Local Chassis**

- General I/O module operation 2-2
- Using input modules 2-10
- Using output modules 2-14

**Locking Tab 1-4****Logix5550 Controller P-1, 2-2**

- Bidirectional connections 2-6, 2-8

**Loss of Field Power 3-13, 4-18****Loss of Field Power Detection**

- Diagnostic output modules 4-24

**M****Major Revision P-3, 3-4, 4-4, 6-3**

- Choosing in RSLogix 5000 6-5
- Considerations for timestamping 3-9, 4-9

**Marking Diagnostic Data Changes 4-11****Mechanical Keying 1-4****Message Instructions**

- In ladder logic B-1

**Minor Revision P-3, 3-4, 4-4, 6-3**

- Choosing in RSLogix 5000 6-5

**Module Compatibility**

- Diagnostic input modules 4-1
- Diagnostic output modules 4-2
- Nondiagnostic input modules 3-1
- Nondiagnostic output modules 3-2

**Module Fault Word**

- Diagnostic input modules 4-25, 4-26
- Diagnostic output modules 4-27, 4-28
- Standard input modules 3-18
- Standard output modules 3-19, 3-20

**Module Identification Information 1-5, B-14**

- ASCII text string 1-5
- Catalog code 1-5
- Major revision 1-5
- Minor revision 1-5
- Product type 1-5
- Retrieving 3-3, 4-3
- Serial number 1-5
- Status 1-5
- Vendor ID 1-5
- WHO service 1-5

**Module Services**

- In ladder logic B-2

**Module Status**

- Retrieving 1-5, B-14

**Module Tags**

- Accessing in RSLogix 5000 6-23, A-11

Changing configuration A-12

Diagnostic input modules A-6

Diagnostic output modules A-8

Sample series (input module) A-15

Sample series (output module) A-16

Standard input modules A-3

Standard output modules A-4

**Module-Specific Information**

1756-IA16 7-2

1756-IA16I 7-4

1756-IA8D 7-6

1756-IB16 7-8

1756-IB16D 7-10

1756-IB16I 7-12

1756-IB32 7-14

1756-IC16 7-16

1756-IH16I 7-18

1756-IM16I 7-20

1756-IN16 7-22

1756-IV16 7-24

1756-IV32 7-26

1756-OA16 7-28

1756-OA16I 7-30

1756-OA8 7-32

1756-OA8D 7-34

1756-OA8E 7-36

1756-OB16D 7-38

1756-OB16E 7-40

1756-OB16I 7-42

1756-OB32 7-44

1756-OB8 7-46

1756-OB8EI 7-48

1756-OC8 7-50

1756-OH8I 7-52

1756-ON8 7-54

1756-OV16E 7-56

1756-OW16I 7-58

1756-OX8I 7-60

**Multiple Owners**

- Of input modules 2-18

**N****NEMA Clamp RTB 5-4****Network Update Time (NUT) P-3****No Load Detection**

- Diagnostic output modules 4-21

**No Load Word**

- Diagnostic output modules 4-27, 4-28

**O****Online Services**

- Input modules 6-21
- Output modules 6-22

**Open Wire Detection** 4-15**Open Wire Word**

- Diagnostic input modules 4-25, 4-26

**Output Data Echo** 2-14, 2-17, 3-13, 4-18**Output Fault State**

- Configurable in RSLogix 5000 3-12

**Output Fault States**

- Configuring in RSLogix 5000 4-17

**Output Online Services** 6-22**Output Verification**

- Diagnostic output modules 4-22

**Output Verify Word**

- Diagnostic output modules 4-27, 4-28

**Owner Controller**

- Logix5550 Controller P-1, 2-2

**Ownership** 2-2

- Direct connections 2-6
- Listen-only 2-17
- Listen-only rack optimization 2-7
- Multiple owners P-3
- Multiple owners of input modules 2-18
- Owner controller P-3
- Owner-controller-I/O module relationship 2-2
- Rack connection P-3, 2-7
- Rack optimization 2-7, 2-8
- Remote connections P-3, 2-11, 2-15

**P****Point Level Fault Reporting**

- Diagnostic modules 4-12

**Preventing Electrostatic Discharge** 1-6**Producer/Consumer**

- Communications 1-1
- Network model 1-1, 2-9, 2-14, 3-9, 4-9

**Product Identification**

- Catalog number 3-4, 4-4
- Major revision P-3, 3-4, 4-4
- Minor revision P-3, 3-4, 4-4
- Product type 3-4, 4-4
- Vendor 3-4, 4-4

**Program Mode** P-3

- Reconfiguring the module 6-18

**Pulse Test**

- Diagnostic output modules 4-22
- Performing with ladder logic B-13
- Usage tips 4-22

**R****Rack Connection** 2-7, 2-8

- Usage recommendations 2-8

**Rack Connections** P-3, 2-7**Rack Optimization** P-3, 2-7, 2-8, 6-6**Rack Optimization Communications Format** 6-8**Remote Chassis**

- Configuring remote I/O modules 6-19
- General I/O module operation 2-3
- Using input modules 2-11
  - Scenarios for data transfer 2-13
- Using output modules 2-15
  - Scenarios for data transfer 2-16

**Remote Connections** P-3**Remote Run Mode**

- Reconfiguring the module 6-17

**Removable Terminal Block (RTB)** P-3, 1-2, 1-4, 5-2

- Installing 5-10
- Mechanically keying the RTB 5-2
- Removing 5-12
- Using with the housing 5-7
- Wiring the RTB 5-4

**Removal and Insertion Under Power (RIUP)** P-3, 1-1, 1-6, 3-3, 4-3, 5-1**Requested Packet Interval (RPI)** P-3, 2-10, 3-11, 4-14, 4-16, 4-25

- Adjusting in RSLogix 5000 6-10, 6-18

**Retrieving Module Identification Information** 1-5, B-14**Retrieving Module Status** 1-5, B-14**RSLogix 5000**

- Configuring I/O modules 2-2, 3-3, 4-3, 6-2
- Filter times 3-11, 4-14
- I/O modules in remote chassis 2-3
- Using software configuration tags A-1
- Using to troubleshoot 8-4
- Using with RSNetWorx 2-2

**RSNetWorx**

- I/O modules in remote chassis 2-3
- Transferring data to networked I/O modules and establishing a NUT 2-2
- Using with RSLogix 5000 2-2

## S

### Scheduled Output Data Communications Format 6-7

### Scheduled Outputs 3-7, 4-7

Choosing in RSLogix 5000 6-7

Usage tips 3-8, 4-8

Used with timestamping 3-8, 4-8

Used with timestamping in ladder logic B-10

### Software Configuration Tags A-1

#### Specifications

1756-IA16 module 7-3

1756-IA16I module 7-5

1756-IA8D module 7-7

1756-IB16 module 7-9

1756-IB16D module 7-11

1756-IB16I module 7-13

1756-IB32 module 7-15, 7-27

1756-IC16 module 7-17

1756-IH16I module 7-19

1756-IM16I module 7-21

1756-IN16 module 7-23

1756-IV16 module 7-25

1756-OA16 module 7-29

1756-OA16I module 7-31

1756-OA8 module 7-33

1756-OA8D module 7-35

1756-OA8E module 7-37

1756-OB16D module 7-39

1756-OB16E module 7-41, 7-57

1756-OB16I module 7-43

1756-OB32 module 7-45

1756-OB8 module 7-47

1756-OB8EI module 7-49

1756-OC8 module 7-51

1756-OH8I module 7-53

1756-ON8 module 7-55

1756-OV16E module 7-57

1756-OW16I module 7-59

1756-OX8I module 7-61

### Spring Clamp RTB 5-5

### Standard-Depth Housing 5-8

### Status Indicators 1-4

Input modules 8-2

Output modules 8-3

### Status Reporting

Diagnostic input modules 4-25

Diagnostic output modules 4-27

Standard input modules 3-18

Standard output modules 3-19

## System Time

Adjusting the RPI 6-10

Choosing a timestamped input communications format 6-6

Choosing a timestamped output communications format 6-7

Diagnostic timestamp 4-11

Schedule outputs 3-7, 4-7

Timestamping inputs 3-7, 4-7

Using scheduled outputs with timestamping 3-8, 4-8

Using timestamping P-3, 1-1

## T

### Tag Editor

Downloading new configuration A-14

### Timestamping 6-6, 6-7

Considering module major revision 3-9, 4-9

Diagnostic Timestamp 4-11

For a sequence of events 3-7, 4-7

Marking input data change with relative time reference P-3, 3-7, 4-7

System timestamp 1-1

Tip for using change of state 3-7, 4-7

Used with scheduled outputs 3-8, 4-8, 6-8, B-10

### Tips

Conserving ControlNet bandwidth 2-11

Electronic keying options 3-5, 4-5

Scheduled outputs 3-8, 4-8

Using change of state in timestamping 3-7, 4-7

Using listen-only communications format 6-6

Using pulse test 4-22

### Troubleshooting

Fault status 3-10, 4-10

Fuse status 3-10, 4-10

I/O status 3-10, 4-10

Module status 3-10, 4-10

Module status indicators 1-4, 3-10, 4-10, 8-1, 8-2

Using RSLogix 5000 8-4

### Types of ControlLogix I/O Modules 1-2

## U

### UL Certification 1-1, 3-11, 4-11

## W

### Warnings

Preventing electrostatic discharge 1-6

Removal and insertion under power (RIUP) 1-6

**Wiring Connections**

- Choosing the extended-depth housing 5-8
- Field wiring options 3-14, 4-19
- Isolated and non-isolated modules 3-12, 4-14
- Recommendations for wiring RTB 5-5
- Using the cage clamp RTB 5-4
- Using the interface module (IFM) P-2, 1-2
- Using the NEMA clamp RTB 5-4
- Using the removable terminal block (RTB) P-3, 1-2, 5-2, 5-4
- Using the spring clamp RTB 5-4

**Wiring Example**

- 1756-IA16 module 7-2
- 1756-IA16I module 7-4, 7-30
- 1756-IA8D module 7-6
- 1756-IB16 module 7-8, 7-24
- 1756-IB16D module 7-10
- 1756-IB16I module 7-12
- 1756-IB32 module 7-14, 7-26
- 1756-IC16 module 7-16
- 1756-IH16I module 7-18
- 1756-IM16I module 7-20
- 1756-IN16 module 7-22
- 1756-IV16 module 7-24
- 1756-OA16 module 7-28
- 1756-OA16I module 7-30
- 1756-OA8 module 7-32
- 1756-OA8D module 7-34
- 1756-OA8E module 7-36
- 1756-OB16D module 7-38
- 1756-OB16E module 7-40, 7-56
- 1756-OB16I module 7-42
- 1756-OB32 module 7-44
- 1756-OB8 module 7-46
- 1756-OB8EI module 7-48
- 1756-OC8 module 7-50
- 1756-OH8I module 7-52
- 1756-ON8 module 7-54
- 1756-OV16E module 7-56
- 1756-OW16I module 7-58
- 1756-OX8I module 7-60

## Notes:



# Allen-Bradley Publication Problem Report

If you find a problem with our documentation, please complete and return this form.

Pub. Title/Type ControlLogix Digital I/O Modules User Manual

Cat. No. 1756-Series Pub. No. 1756-UM058C-EN-P Pub. Date March 2001 Part No. 957345-93

Check Problem(s) Type:	Describe Problem(s)	Internal Use Only
<input type="checkbox"/> Technical Accuracy	<input type="checkbox"/> text <input type="checkbox"/> illustration	
<input type="checkbox"/> Completeness What information is missing?	<input type="checkbox"/> procedure/step <input type="checkbox"/> illustration <input type="checkbox"/> definition	<input type="checkbox"/> info in manual (accessibility)
	<input type="checkbox"/> example <input type="checkbox"/> guideline <input type="checkbox"/> feature	<input type="checkbox"/> info not in manual
	<input type="checkbox"/> explanation <input type="checkbox"/> other	
<input type="checkbox"/> Clarity What is unclear?		
<input type="checkbox"/> Sequence What is not in the right order?		
<input type="checkbox"/> Other Comments Use back for more comments.		

Your Name \_\_\_\_\_ Location/Phone \_\_\_\_\_

Return to: Marketing Communications, Allen-Bradley., 1 Allen-Bradley Drive, Mayfield Hts., OH 44124-6118 Phone:(440) 646-3176  
 FAX:(440) 646-4320

Other Comments

PLEASE FOLD HERE

PLEASE REMOVE

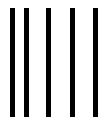

NO POSTAGE  
NECESSARY  
IF MAILED  
IN THE  
UNITED STATES

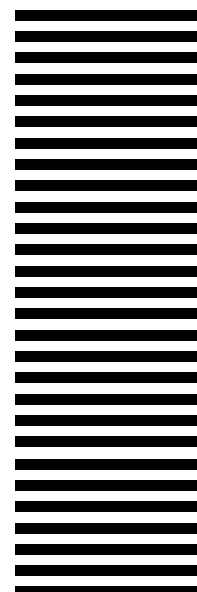

**BUSINESS REPLY MAIL**

FIRST-CLASS MAIL PERMIT NO. 18235 CLEVELAND OH

POSTAGE WILL BE PAID BY THE ADDRESSEE



**Rockwell  
Automation**

**1 ALLEN-BRADLEY DR  
MAYFIELD HEIGHTS OH 44124-9705**





[www.rockwellautomation.com](http://www.rockwellautomation.com)

---

**Power, Control and Information Solutions Headquarters**

Americas: Rockwell Automation, 1201 South Second Street, Milwaukee, WI 53204-2496 USA, Tel: (1) 414.382.2000, Fax: (1) 414.382.4444

Europe/Middle East/Africa: Rockwell Automation, Vorstlaan/Boulevard du Souverain 36, 1170 Brussels, Belgium, Tel: (32) 2 663 0600, Fax: (32) 2 663 0640

Asia Pacific: Rockwell Automation, Level 14, Core F, Cyberport 3, 100 Cyberport Road, Hong Kong, Tel: (852) 2887 4788, Fax: (852) 2508 1846

Publication 1756-UM058C-EN-P - March 2001

Supersedes Publication 1756-6.5.8 - July 1999

PN 957345-93

© 2001 Rockwell International Corporation. Printed in the U.S.A.