



Imo Industries Inc.

INSTRUCTION MANUAL

SERIES 3E ROTOR SIZES 143, 143J AND 162

WARNING

**READ CA-1 AND THIS INSTRUCTION MANUAL BEFORE
INSTALLATION, OPERATION OR MAINTENANCE**

INSTRUCTIONS 3E-C (R-2)

MANUFACTURING FACILITIES

IMO Industries Inc.
IMO Pump Division
P.O. Box 5020, Airport Road
Monroe, NC 28111-5020
USA
Phone: 704-289-6511

IMO Industries Inc.
IMO Pump Division
Industrial Park Road
Columbia, Kentucky 42728
USA

January, 1991

The instructions given herein cover generally the operation and maintenance of subject equipment. Should any questions arise which may not be answered specifically by these instructions, they should be referred to IMO Pump Division for further detailed information and technical assistance. 704-289-6511, Ext. 343, 349 or 358.

This manual cannot possibly cover every situation connected with the operation, adjustment, inspection, test, overhaul and maintenance of the equipment furnished. Every effort is made to prepare the text of the manual so that engineering and design data is transformed into the most easily understood wording. IMO Pump Division, in furnishing this equipment and this manual, must presume that the operating and maintenance personnel assigned thereto have sufficient technical knowledge and experience to apply sound safety and operational practices which may not be otherwise covered herein.

In applications where IMO Pump Division furnished equipment is to be integrated with a process or other machinery, these instructions should be thoroughly reviewed to determine the proper integration of the equipment into the overall plant operational procedures. On critical or dangerous equipment, provide suitable safety and emergency systems to protect personnel and property from injury due to pump malfunction. If pump handles flammable, toxic, corrosive or explosive fluids, provide for safety in the event of pump leakage or malfunction.

If the installation, operation, and maintenance instructions are not correctly and strictly followed and observed, serious damage to the pump could result. IMO Pump Division cannot accept responsibility for unsatisfactory performance or damage resulting from failure to comply with instructions.

A

FOREWORD

This instruction manual covers the 3E Series IMO pumps. Specific models covered by this manual are identified in Table 1. The model of each particular pump is identified on the pump end cover. Refer to Figure 1 for definitions of model designators. Refer to assembly drawing corresponding to your pump model, Figures 4 through 14, as you use this instruction manual.

**Table 1
3E SERIES PUMP MODELS**

ROTORS 143J, 143 AND 162					
PUMP MODEL	FIGURE NUMBER	PUMP MODEL	FIGURE NUMBER	PUMP MODEL	FIGURE NUMBER
C3EBC	14	C3EPF	8	D3EHFS	7
C3EBCX	4	C3EX	12	D3EHTFS	7
C3EBF	6	C3EXC	8	D3EICS	11
C3EHC	4	C3EXFT	6	D3EPFS	9
C3EHF	6	D3EBCS	5	D3EXS	13
C3EHJF	6	D3EBFS	7	D3EXFS	7
C3EIC	10	D3EBTCS	5	D3EXS	5
C3ENC (Inset)	4	D3EBTFS	7		
C3ENVC (Inset)	4	D3EHCS	5		

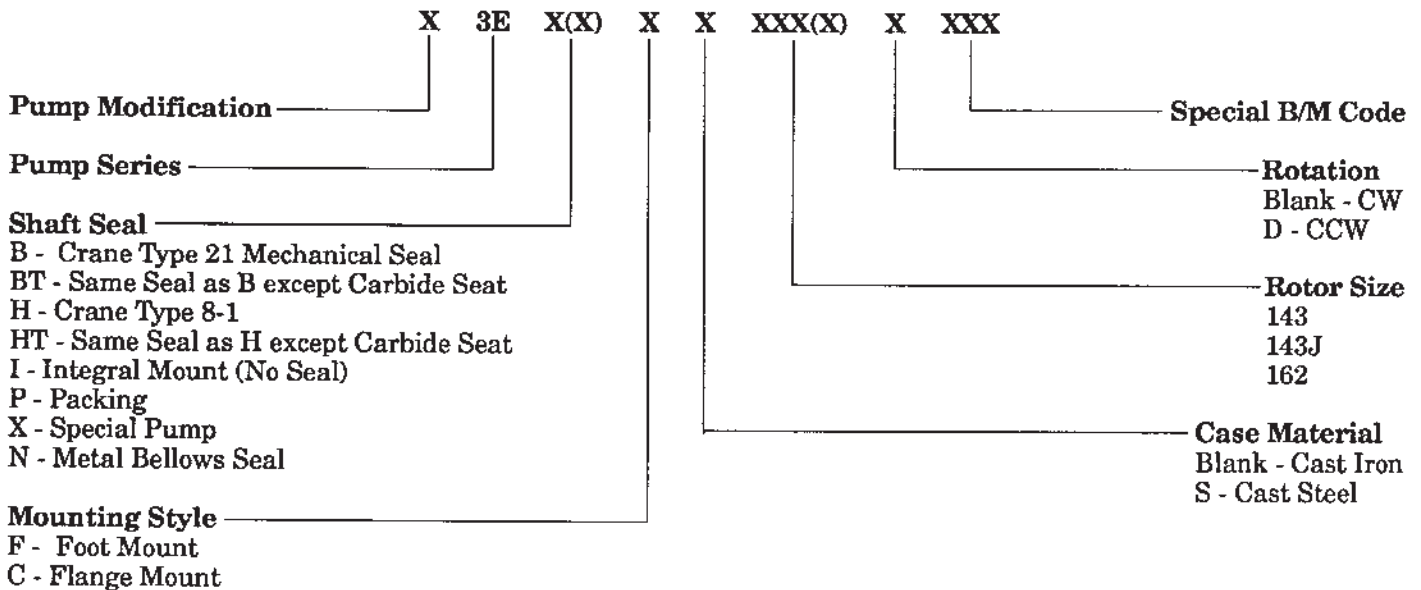

Figure 1. Definitions of Model Designators
STRUCTURAL LIMITS

Operating conditions, such as speed, fluid viscosity, inlet pressure, discharge pressure, temperature, filtration, duty cycle, mounting, drive type, etc. are interrelated. Due to these variable conditions, the specific application may be different from that of the structural limitations. This equipment must not be operated without verification that operating requirements are within published capabilities as shown in the appropriate pump data (available from local IMO Pump Division offices and representatives listed in CA-1 manual). *Under no circumstances are the following structural limitations to be exceeded.*

MAXIMUM SPEED: Contact the IMO Pump Division for Rating Tables. For No. 6 fuel oil, crude oil and other fluids known to contain fine abrasives, pump speed should not exceed 1800 RPM.

VISCOSITY: 2.0 cst (33 SSU) minimum
 3000 SSU maximum for type B mechanical seal. 25,000 SSU maximum for type H mechanical seal.
 Type B mechanical seal is not recommended for use when using No. 6 fuel oil regardless of specified operating viscosity range.

TEMPERATURE: Type B Mechanical Seal Pump - 0° to 180°F
 Type H Mechanical Seal, Integral Mount, and Packing Pumps - 0° to 250°F

SUCTION: 25 PSIG Maximum

DISCHARGE PRESSURE: 150 PSIG Maximum

DRIVE: Direct Only

FILTRATION: Light fluids - 60 mesh
 Heavy fluids - 1/16 to 1/8 - inch

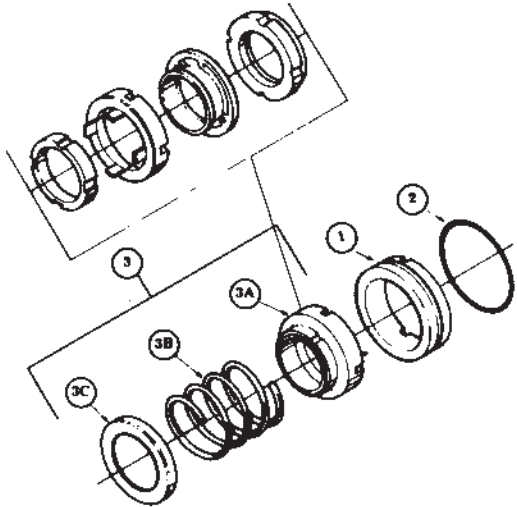

- 1. SEAT
- 2. O-RING
- 3. ROTATING ASSEMBLY
- 3A. WASHER BELLOWS ASSEMBLY
- 3B. SPRING
- 3C. SPRING HOLDER

FIGURE 2. Crane Type 21 Mechanical Seal

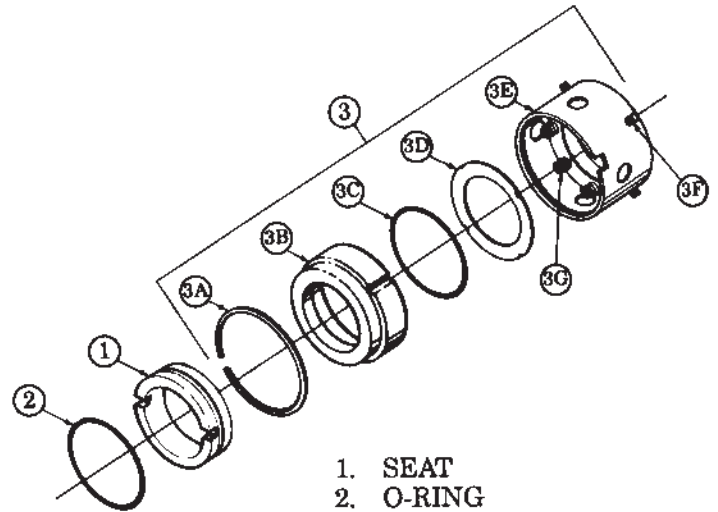

- 1. SEAT
- 2. O-RING
- 3. ROTATING ASSEMBLY
- 3A. SNAP RING
- 3B. WASHER
- 3C. O-RING
- 3D. DISC
- 3E. RETAINER
- 3F. SET SCREW
- 3G. SPRING

FIGURE 3. Crane Type 8-1 Mechanical Seal

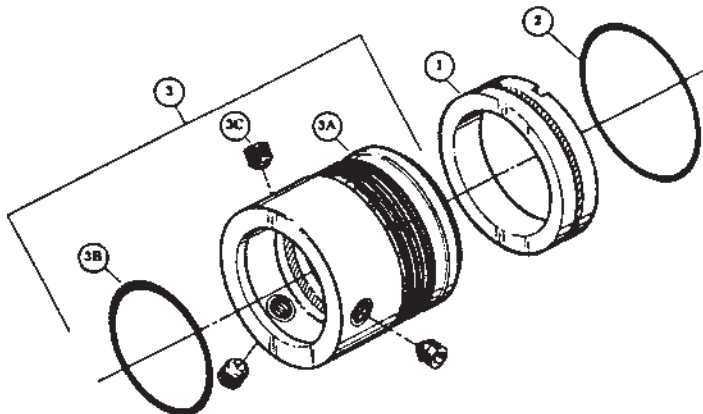

- 1. SEAT
- 2. O-RING
- 3. ROTATING ASSEMBLY
- 3A. BELLOWS ASSEMBLY
- 3B. BELLOWS ASSEMBLY O-RING
- 3F. SETSCREW

FIGURE 3A. Show Metal Bellows Mechanical Seal Assembly Figure

MAINTENANCE

General. To perform maintenance on the Series 3E pumps, the following initial conditions shall be completed prior to the maintenance action: Close the inlet and outlet valves and tag "Out of Service." De-energize pump drive motor controller and tag "Out of Service." Vent all pressure from pump housing. Remove pump from driver and remove coupling from pump. Remove coupling key (013).

SERVICING MECHANICAL SEAL AND BEARING (Figures 4 through 7 and 14)

Removal of Seal and Bearing: Complete **General** steps, then remove retainer bolts (006) and retainer (012). Grasp power rotor (007) and pull the assembled power rotor (007) from pump. Disassemble power rotor as follows:

- (a) Remove retaining ring (015) from groove of power rotor. (Figure 14 only remove outer ring 015). Support sleeve subassembly (092 or 093) and press power rotor (007) from bearing (011) and sleeve subassembly (092 or 093). Remove bearing (011) from sleeve subassembly (092 or 093). Remove mechanical seal seat (1, Figures 2 and 3) with O-ring (2, Figures 2, 3 or 4) from sleeve subassembly (092 or 093) and remove O-ring from seat, if required. Remove O-ring (093 or 094) from groove of sleeve (092 or 093). (Figure 14 only remove inner retaining ring (015) from power rotor).
- (b) Remove rotating assembly (3, Figures 2 and 3) of mechanical seal (016) from power rotor (007) as outlined below.
 - (1) **Crane Type 21 (Figure 2).** Slide rotating assembly 3 from power rotor (007).
 - (2) **Crane Type 8-1 and Typical Metal Bellows (Figure 3 and 3A).** Loosen setscrews (3F) and slide rotating assembly (3) from rotor (007).

NOTE

Idler stop (009) and sleeve (025) are factory assembled on power rotor (007) and should not be removed.

Installation of Seal and Bearing: Clean and inspect each part for burrs or nicks. Remove all burrs. Particular attention must be given to the keyway and retaining ring groove of power rotor (007) and sleeve (025) to ensure all sharp edges are removed. Sharp edges on sleeve (025) may cut or shave mechanical seal when it is placed into the installed position. Wipe all parts with lubricating oil (SAE-30) prior to installing.

- (a) With power rotor (007) and mechanical seal rotating assembly (3, Figures 2 and 3 and 3A) coated with lubricating oil, install the rotating assembly (3, Figures 2 and 3 and 3A) on power rotor (007) as follows:
 - (1) **Crane Type 21 (Figure 2).** Slide rotating assembly (3) on sleeve (025) until rotating assembly (3) is positioned next to idler stop (009).
 - (2) **Crane Type 8-1 (Figure 3).** Slide rotating assembly (3) on sleeve (025) until rotating assembly (3) is positioned next to idler stop (009). Tighten setscrews (3F).
- (b) Slide mechanical seal O-ring (2, Figures 2 and 3 and 3A) in O-ring groove of mechanical seal seat (1, Figures 2 and 3). Align seat (1, Figures 2 and 3) slot with spring pin (095) located in sleeve subassembly (092 or 093) and slide assembled seat in sleeve subassembly. Apply lubricating oil on running faces of mechanical seal seat (1, Figures 2 and 3). Install O-ring (093 or 094) in groove of sleeve (092 or 093). Install assembled sleeve subassembly (092 or 093) on power rotor (007) with seal seat contacting installed rotating assembly. Install one retaining ring (015) into groove on power rotor (007) furthest from shaft coupling end.
- (c) Support power rotor (007) and press ball bearing (011) on power rotor (007) shaft, pressing only on bearing inner race until bearing just passes retaining ring (015) groove in power rotor. Install retaining ring (015) in groove of power rotor (007), ensuring that ball bearing (011) is contacting retaining ring (015) and ball bearing is bottomed out against the sleeve subassembly (092 or 093).

- (d) Install assembled power rotor, centering each part as it enters cover (004). NOTE: Sleeve subassembly (092 or 093) drain port is to be aligned with drain port in cover (004).
- (e) Rotate power rotor to ensure freedom of rotation.
- (f) Install retainer (012) on cover (004) using bolts (006). Tighten bolts (006) to a torque value of 40 lbs. inch (± 5 lbs. inch).
- (g) Install key (013) and coupling hub on power rotor (007). Install pump on driver and check alignment as described in CA-1 manual. Prime pump to expel all air prior to starting.

SERVICING PACKING (Figures 8 and 9)

Removal of Packing: Complete **General** steps, then remove bolts (030). Slide packing gland (031) off power rotor (007). Using a "packing puller" or sharp pointed brass or copper rod, remove four rings of packing (029).

Installation of Packing: Clean and inspect power rotor for nicks and burrs. Using a buffer wheel, remove all burrs. Wipe all parts with lubricating oil (SAE-30) prior to installation.

- (a) Install four rings of packing (029) in cover (004) packing bore. Set each packing (029) ring individually and firmly in place with joints of rings staggered.
- (b) Install Packing gland (031) using bolts (030). Tighten bolts (030) only enough to position gland (031) next to packing (029). Packing gland bolts (030) should be tightened, when pump is running, to allow for approximately eight drops per minute of seepage. NOTE: Packing should not be set so tight that it will score sleeve (072).
- (c) Pull power rotor in the axial direction until power rotor contacts cover (004). Power rotor must remain in the "pulled out" position when pump is attached to driver.

DISASSEMBLY AND ASSEMBLY PROCEDURES (Figures 4 through 7 and 14)

Disassemble pump by first completing steps outlined in Removal of Mechanical Seal and Bearing. Continue to disassemble pump as follows:

- (a) Remove bolts or capscrews (027) and cover (004) from case (001). Remove O-ring (026) from either case (001) or cover (004).
- (b) Remove bolts (003) and cover (002) from case (001). Clean Loctite gasket eliminator from cover (002) and flange of case (001).
- (c) Remove idlers (008) from idler bores.
- (d) **Steel Case Pump Only (Figures 5 or 7).** Remove housing (075) with O-ring (076) from case (001). Remove O-ring (076) from groove of housing (075).

Prior to assembly of pump, check each part and remove any burrs by buffing. Wipe all parts with lubricating oil (SAE-30) prior to assembly. Rotate power rotor frequently during assembly to ensure freedom of rotation. Assemble pump as follows:

- (a) **Steel Case Pump Only (Figure 5 or 7).** Install O-ring (076) in groove of housing (075) and install housing (075) in case (001), ensuring that anti-rotation groove in housing (075) is aligned with anti-rotation boss in case (001).
- (b) Install idlers (008) in idler bores.
- (c) Wipe all traces of oil from mating flange of cover (002) and flange of case (001). Apply a thin coat of Loctite gasket eliminator No. 504 to cover (002) and flange of case (001). Install cover (002) to case (001) using bolts (003). Torque bolts (003) to a torque value of 170 lbs. inch (± 5 lbs. inch).

- (d) Install O-ring (026) over cover (004) flange. Install cover (004) with drain port down to case (001) using bolts or capscrews (027). Torque bolts or capscrews (027) to a torque value of 170 lbs. inch (± 5 lbs. inch).

NOTE

Cover (004), aligned with drain in sleeve subassembly (092), is equipped with a drain port that prevents fluid being pumped from contaminating ball bearing (011) if mechanical seal failure occurs. Install cover (004) on pump so that drain opening will be down when pump is installed.

NOTE

When pumping clean lubricating oil, the seal drain port in cover (004) may be installed in any attitude.

- (e) Complete assembly of pump by following steps outlined in Installation of Seal and Bearing.

DISASSEMBLY AND ASSEMBLY PROCEDURES (Figures 8 through 13)

Prepare pump for disassembly following **General** steps.

(Figures 8 and 9). Disassemble pump by first completing steps outlined in Removal of Packing.

(Figure 12). Remove adapter (028) and gasket (018) from flange of case (001). **NOTE:** Adapter (028) is retained by special mounting of pump.

Complete disassembly of Figures 9 through 13 pumps as follows:

- (a) Remove bolts or capscrews (027) and cover (004) from case (001). Remove O-ring (026) from either cover (004) or case (001). **(Figures 10 through 13)** Clean Loctite compound from heads of capscrews (027).

NOTE

(Figure 9). Cover (004) is factory assembled with parts (040, 041 and 042) and is not to be disassembled.

(Figure 11 and 13). Cover (004) is factory assembled with parts (040, 041, 042 and 043) and is not to be disassembled.

- (b) Grasp power rotor (007) and pull power rotor (007) and idlers (008) from pump. **DO NOT** permit idlers to fall as they are removed from pump.

NOTE

(Figures 8 and 9). Power rotor (007) is factory assembled with parts (070, 071, 072, 073 and 074) and is not to be disassembled.

NOTE

(Figures 10 through 13). Idler stop (009) and piston (024) are factory assembled on power rotor (007) and should not be removed.

- (c) Remove bolts (003) and cover (002). Clean Loctite gasket eliminator No. 504 from cover (002) and flange of pump case (001).
- (d) **Steel Case Pump Only (Figures 9, 11 or 13).** Remove housing (075) from case (001). Remove O-ring (076) from groove of housing (075).

Prior to assembly of pump, check each part and remove any burrs by buffing. Wipe all parts with lubricating oil (SAE-30) prior to assembly. Rotate power rotor (007) frequently during assembly to ensure freedom of rotation. Assemble pump as follows:

- (a) **Steel Case Pump Only (Figure 9, 11 or 13).** Install O-ring (076) in groove of housing (075) and install housing (752) in case (001), ensuring that anti-rotation groove in housing (075) is aligned with anti-rotation boss in case (001).
- (b) Wipe all traces of oil from mating flange of cover (002) and pump case (001) and apply a thin coat of Loctite gasket eliminator No. 504 to both cover (002) and case (001) using bolts (003). Torque bolts (003) to 170 lbs. inch (± 5 lbs. inch).
- (c) Mesh idlers (008) with power rotor (007) and install assembly into pump rotor bores.
- (d) Install O-ring (026) on cover (004) flange.
- (e) **(Figures 10 through 13).** Apply Loctite gasket eliminator No. 510 under heads of capscrews (027).
- (f) Install cover (004) on case (001) using bolts or capscrews (027). Torque bolts or capscrews (027) to 170 lbs. inch (± 5 lbs. inch).
- (g) **(Figure 12).** Install gasket (018) and adapter (028) on flange of pump case (001). NOTE: Adapter (028) is retained by special mounting of pump.
- (h) **(Figures 8 and 9).** Complete assembly of pump by following procedures outlined in Installation of Packing.
- (i) Pull power rotor (007) in the axial direction until power rotor contacts cover (004). Power rotor must remain in the "pulled out" position when the pump is attached to driver.
- (j) Install key (013) and coupling hub on power rotor (007). Install pump on driver and check alignment as described in CA-1 manual. Prime pump to expel all air prior to starting.

**TABLE 2
LIST OF MATERIAL FOR FIGURES 4 THROUGH 14**

001		Case	028	Adapter
002	(2)	Cover	029	Packing
003		Bolt (4)	030	Bolt (2)
004	(2) (4)	Cover	031	Gland
005		O-ring	040	Cover (Part of Item 004)
006		Bolt (4)	041	Bushing (Part of Item 004)
007	(2) (5)	Power Rotor Assembly	042	Washer (Part of Item 004)
008	(2)	Idler (2)	043	Roll Pin (Part of Item 004)
009	(2)	Idler Stop (Part of Item 007)	070	Power Rotor (Part of Item 007)
011	(1)	Ball Bearing	071	Piston (Part of Item 007)
012		Retainer	072	Sleeve (Part of Item 007)
013		Key	073	Check Valve (Part of Item 007)
015	(1)	Retaining Ring (2) Figure 14 only	074	Spring Washer (Part of Item 007)
016	(1)	Seal	075 (2)	Housing
018		Gasket	076	O-ring
024	(2)	Piston (Part of Item 007)	092 or 093	Sleeve Sub-Assembly
025	(2)	Sleeve (Part of Item 007)	093 or 094	O-ring
026	(1)	O-ring	095	Spring Pin (Part of Item 092)
027	(3)	Capscrew (4)		

Quantities are one (1) except when noted in parentheses after part description.

- (1) Minor Repair Kit items (iron and steel case pumps).
- (2) Major Repair Kit items (steel case pumps only). Items marked (1) also included in Major Repair Kit.
- (3) Part description is bolt (4) for Figures 6 and 7 pumps.
- (4) Cover (004) assembly includes items 004, 040, and 042 for Figure 9 pumps; items 004, 040, 041, 042 and 043 for Figures 11 and 12 pumps.
- (5) Power rotor (007) assembly includes items 007, 009 and 025 for Figures 4, 5, 6 and 7 pumps; items 007, 070, 071, 072, 073 and 074 for Figures 8 and 9 pumps; items 007, 009 and 024 for Figures 10, 11, 12 and 13 pumps. Power rotor (007) assembly is factory assembled and is furnished as part of Major Repair Kit (steel case pumps only).

REPAIR KITS

Minor Repair Kits are available for iron and steel case pumps. Major Repair Kits are available for steel case pumps only. Major Repair Kits are not available for iron case pumps because major repairs are not considered economical. If extensive repair is required to an iron case pump, the pump should be discarded and a new pump purchased. Repair parts are available in kit form only.

ORDERING INSTRUCTIONS

- (1) Give the number of this instruction book.
- (2) Give the model number of pump for which kit is desired.
- (3) Identify the kit (Minor or Major) required.

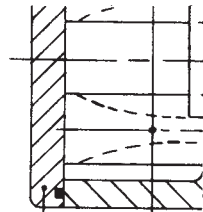
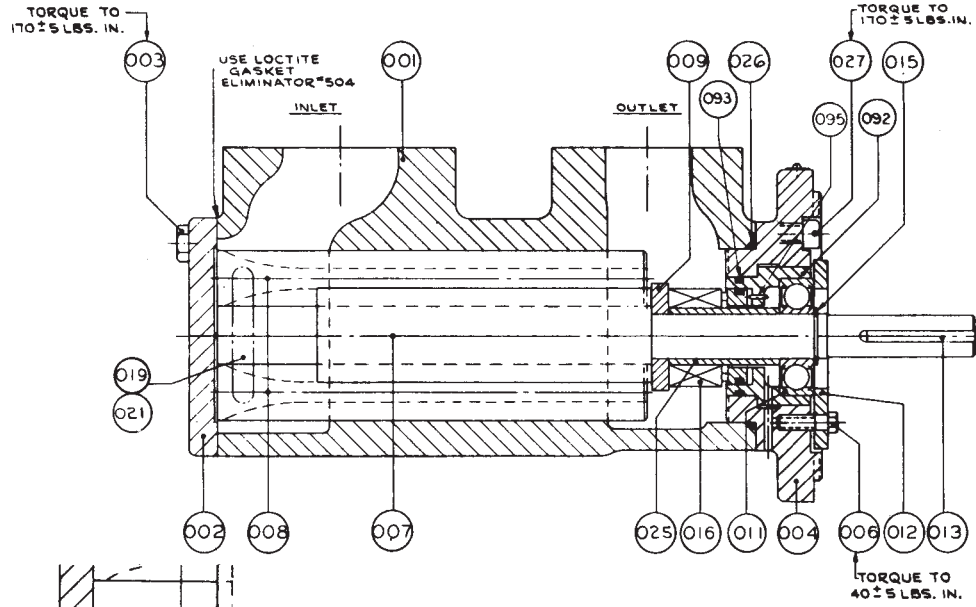

Inset for Type N pumps.
 (High suction pressure).
 Part 005 on Parts list.

FIGURE 4. Assembly Drawing SC-6127 - Inset SC-6150

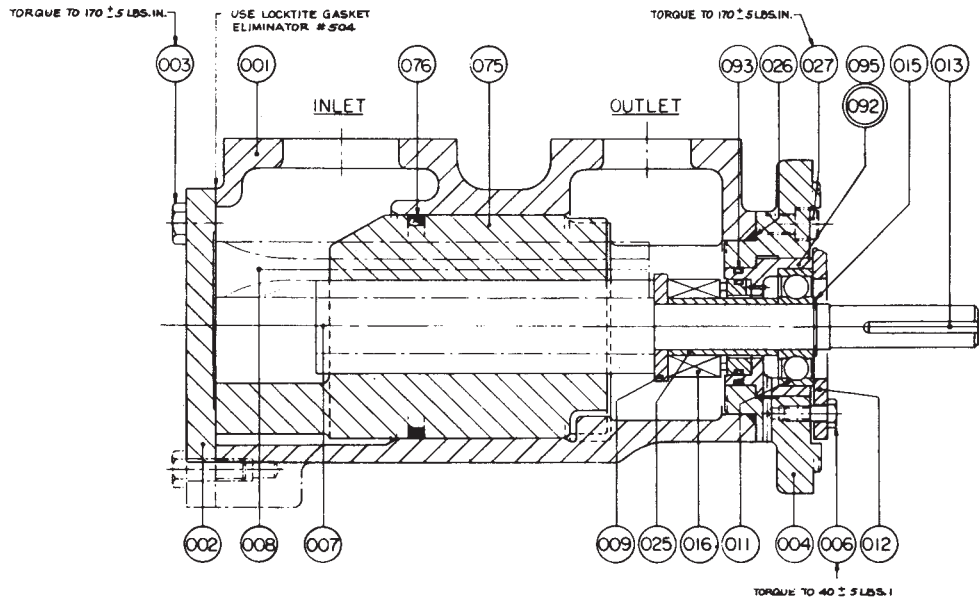

FIGURE 5. Assembly Drawing SC-6145

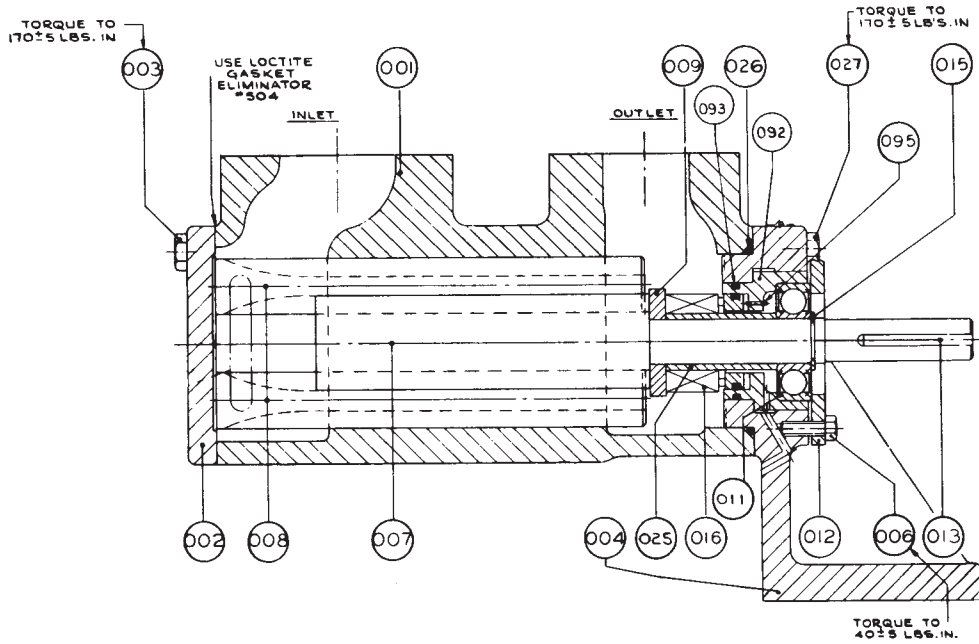

FIGURE 6. Assembly Drawing SC-6128

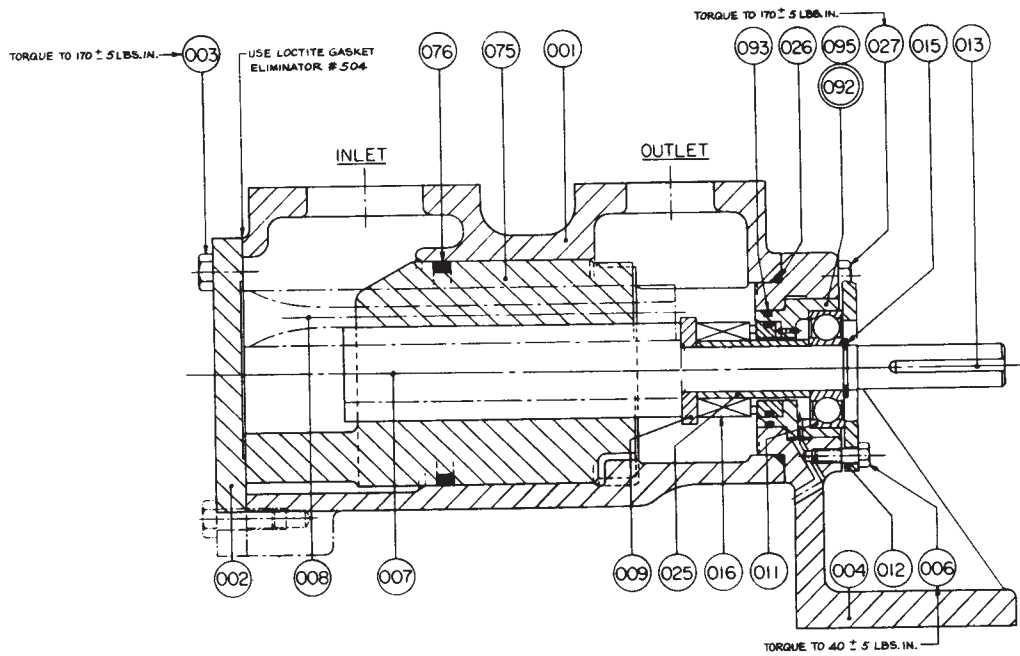

FIGURE 7. Assembly Drawing SC-6146

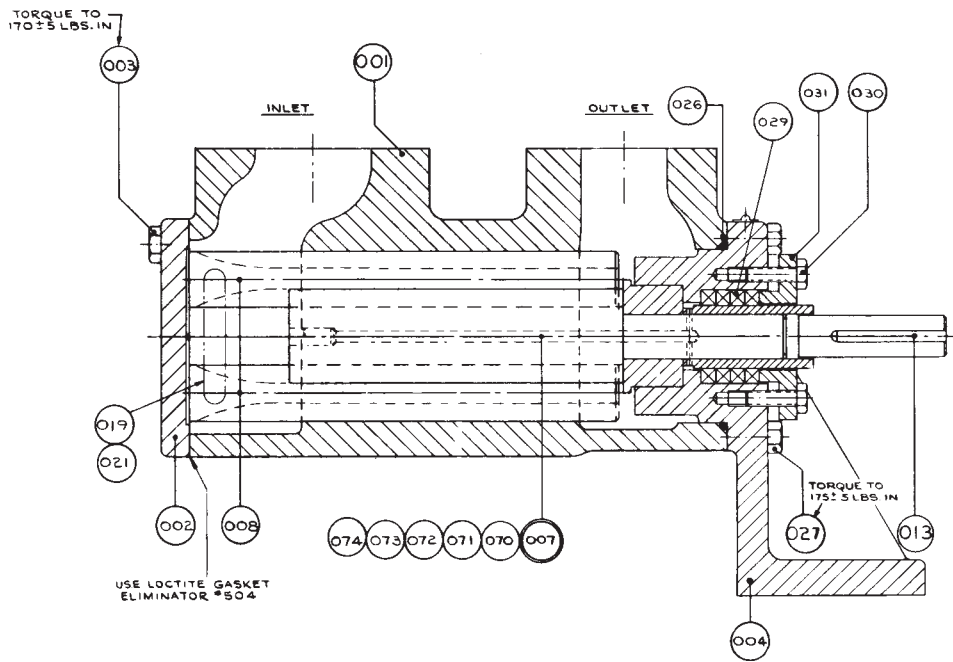

FIGURE 8. Assembly Drawing SC-6126

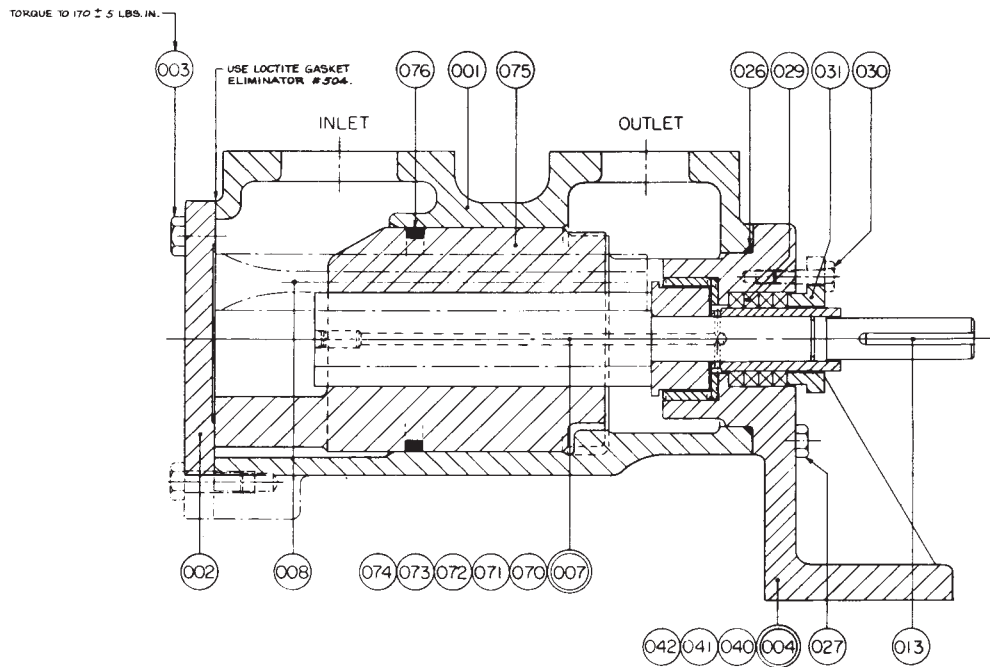

FIGURE 9. Assembly Drawing SC-6144

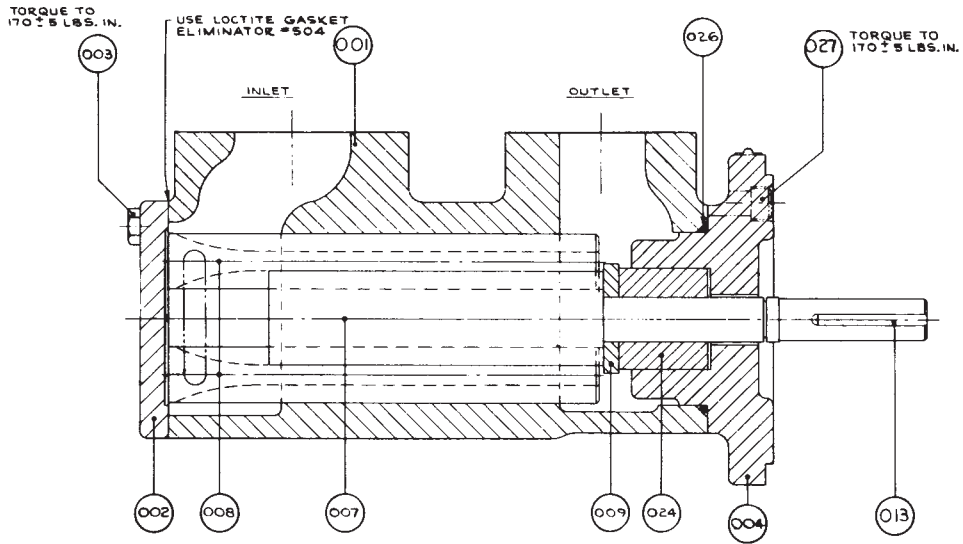

FIGURE 10. Assembly Drawing SC-6125

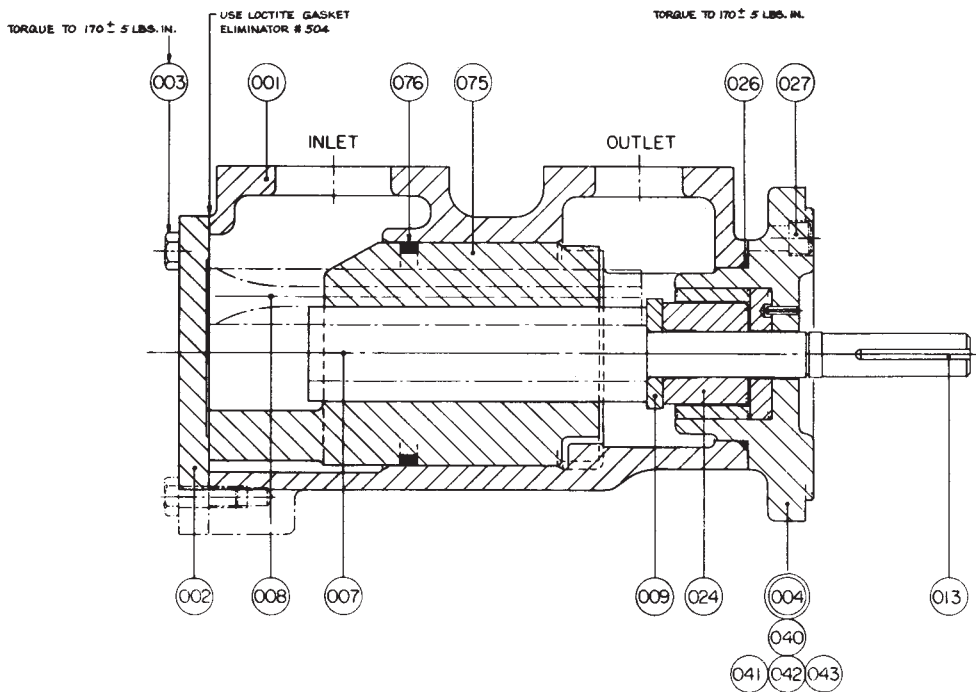
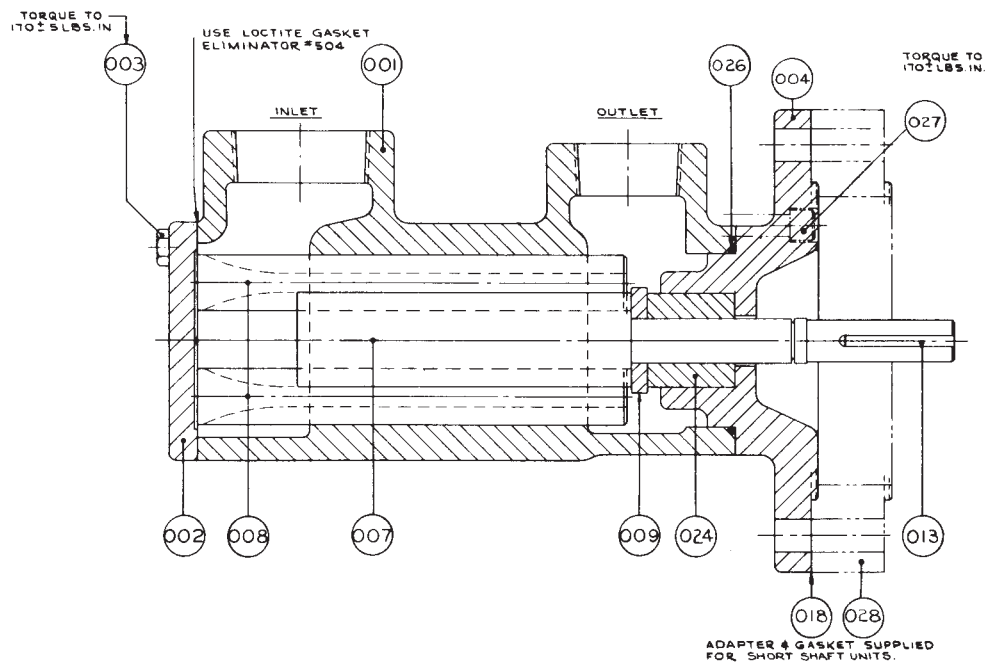

FIGURE 11. Assembly Drawing SC-6143



PUMP TYPES

(Standard Shaft Ext.)

C3EX-143J-501
C3EX-143JD-503

(Short Shaft Ext. w/Adapter)

C3EX-143J-500
C3EX-143JD-502

FIGURE 12. Assembly Drawing SC-6129

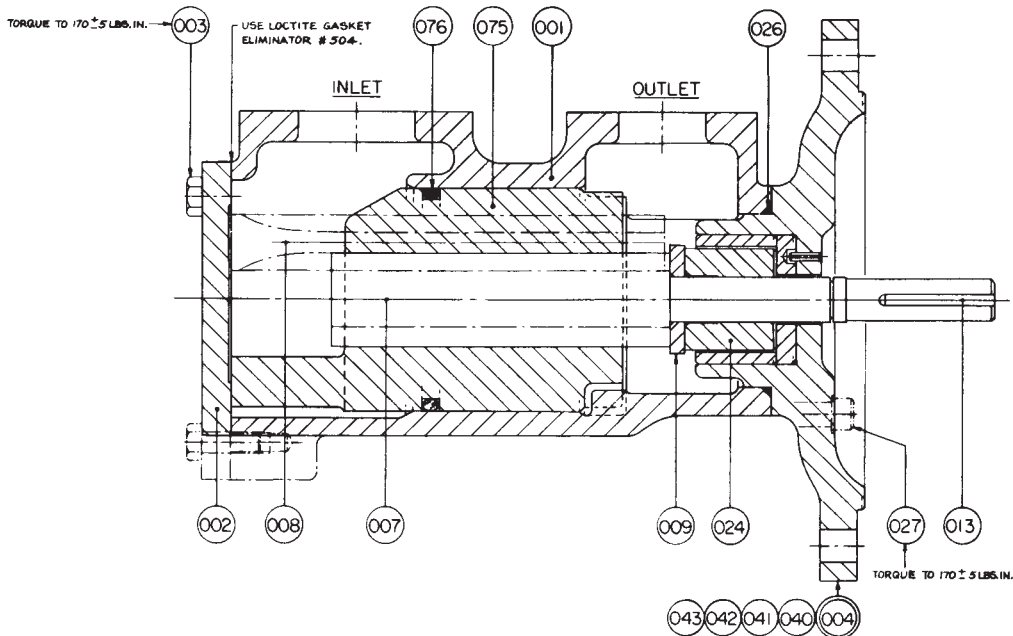

PUMP TYPES

D3EXS-162-522
D3EXS-162D-523
D3EXS-143-502
D3EXS-143D-503

FIGURE 13. Assembly Drawing SC-6147

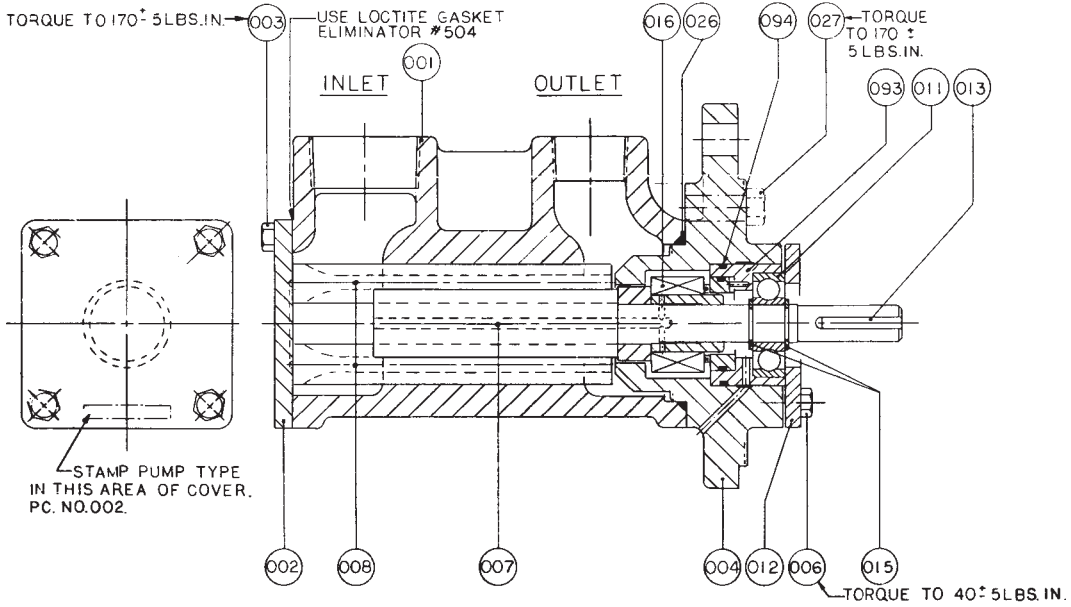

FIGURE 14. Assembly Drawing SC-6149