

DVC6000 Series FIELDVUE® Digital Valve Controllers

Using This Guide

1

Installation

2

Basic Setup and Calibration

3

Specifications and Related Documents

4

Loop Schematics and Nameplates

5



Note

This guide provides installation, and initial setup and calibration information for DVC6000 Series digital valve controllers. See the FIELDVUE® DVC6000 Series Digital Valve Controller Instruction Manual - Form 5647, available from your Emerson Process Management™ sales office, for additional information, or visit our website at www.FIELDVUE.com.

Note: This guide applies to:

DVC6000 Series				375 Field Communicator
Device Revision	Firmware Revision	Hardware Revision	Instrument Level	Device Description Revision
2	7	1	AC, HC, AD, and PD	1

For details see page 1-1



DVC6000 Series

Fast-Key Sequence for Instrument Level HC, AD, PD, and ODV

Function/Variable	Fast-Key Sequence	Coordinates ⁽¹⁾	Function/Variable	Fast-Key Sequence	Coordinates ⁽¹⁾
Actuator Style	1-2-6-4	4-D	Drive Signal Alert Enable	1-2-3-1-2-1	10-C
Alert Conditions	2-1	2-E	End Point Control Enable ⁽³⁾	1-2-2-2-5-1	6-C
Alert Record Full Enable	1-2-3-6-2	8-F	Failure Group Enable	1-2-3-6-5-1	10-G
	1-2-3-7-2			1-2-3-7-5-1	
Alert Record Not Empty Alert Enable	1-2-3-6-1	8-F	Feedback Connection	1-2-6-5	4-D
	1-2-3-7-1		Firmware Revision	3-7-6	4-H
Analog Input	3-1	2-F	Flash ROM Shutdown	1-2-3-1-3-5	11-C
Analog Input Calibration	1-3-2-3	4-E	Hardware Revision	3-7-7	4-H
Analog Input Range Hi	1-2-5-3-1	6-H	HART Tag	1-2-5-1-1	6-F
Analog Input Range Lo	1-2-5-3-2	6-H		3-7-1	4-H
Analog Input Units	1-2-5-2-3	6-G	HART Universal Revision	3-7-9	4-I
Auto Travel Calibration	1-3-1-1	4-E	Input Characterization	1-2-2-3	4-C
Autocalibration in Progress Enable	1-2-4-2-2	8-H	Instrument Date and Time	1-2-4-1-2	8-G
	3-6-1			5-G	1-2-5-8
Auxiliary Input	1-2-3-3-1-2	10-C	Instrument Level	3-7-8	4-H
Auxiliary Terminal Alert Enable	1-2-3-3-1-1	10-C	Instrument Mode	Hot Key-1	1-A
Auxiliary Terminal Mode	1-2-3-3-1-3	10-D		1-2-1-1	4-B
		1-2-5-7	5-F	Instrument Serial Number	1-2-5-1-6
Burst Command	1-2-1-4-2	5-A	Instrument Time Invalid Enable	1-2-4-1-1	8-G
Burst Enable	1-2-1-4-1	5-A	Integral Dead Zone	1-2-4-4-4	8-I
Calibration in Progress Enab	1-2-4-2-1	8-G		1-2-2-1-2-1	9-A
Calibration Location	1-2-5-9-2	6-H	Integral Limit	1-2-4-4-3	8-I
Clear Record	1-2-3-6-4	8-G		1-2-2-1-2-2	9-B
	1-2-3-7-4		Integrator Saturated Hi Enable	1-2-4-4-1	8-I
Command 3 (Trending) Pressure	1-2-1-4-3	5-B	Integrator Saturated Lo Enable	1-2-4-4-2	8-I
Control Mode	Hot Key-2	1-A	Lag Time ⁽⁵⁾	1-2-2-5-3	6-C
	1-2-1-2	4-B	Last Calibration Status	1-2-5-9-1	6-H
Critical NVM Shutdown	1-2-3-1-3-4	11-C	Lead/Lag ⁽³⁾	1-2-2-5-3	6-C
Cycle Count	1-2-3-5-1-2	10-F	Manual Travel Calibration	1-3-1-2	4-E
	3-6-5	4-H	Manufacturer	3-7-3	4-H
Cycle Count Alert Enable	1-2-3-5-1-1	10-F		1-2-6-1	4-D
Cycle Count Alert Point	1-2-3-5-1-3	10-F	Maximum Supply Pressure	1-2-5-6	5-F
Date	1-2-5-1-4	6-F	Message	1-2-5-1-2	6-F
Dead Band (Cycle Count / Travel Accum)	1-2-3-5-2-1	10-F	Miscellaneous Group Enable	1-2-3-6-5-3	10-G
Define Custom Characteristic	1-2-2-4	4-C		1-2-3-7-5-3	
Descriptor	1-2-5-1-3	6-F	Model	3-7-4	4-H
Device Description Information	3-8	2-G	Multi-Drop Alert Enable	1-2-4-3-2	8-H
Device ID	3-7-2	4-H	No Free Time Shutdown	1-2-3-1-3-6	11-C
Device Revision	3-7-5	4-H	Non-Critical NVM Alert Enable	1-2-3-1-3-3	11-B
Diagnostic Data Available Enable	1-2-4-2-4	8-H	Number of Power Ups	2-3-4	4-F
Diagnostic in Progress Enable	1-2-4-2-3	8-H		3-6-9	5-H
Display Record	1-2-3-6-3	8-F	Offline/Failed Alert Enable	1-2-3-1-3-1	11-B
	1-2-3-7-3		Partial Stroke Test	2-5	2-F
Drive Current Shutdown	1-2-3-1-1	9-D	Partial Stroke Test Enable ⁽³⁾	1-2-7-1	3-D
Drive Signal	3-4	2-F	Partial Stroke Test Pressure Limit ⁽³⁾	1-2-3-6-1	8-F
	1-2-3-1-2-2	10-C	Partial Stroke Test Start Point ⁽³⁾	1-2-2-2-5-2	8-C

NOTE: *Italicized Fast-Key Sequence* indicates fast-key sequence is only applicable for instrument level ODV.
1. Coordinates are to help locate the item on the foldout menu tree.
3. Instrument level ODV only.
5. Instrument level HC, AD, and PD only.

continued on facing page

Unfold this sheet to see the 375 Field Communicator Menu Tree for Instrument Level HC, AD, PD, and ODV

DVC6000 Series

375 Field Communicator Menu Tree for FIELDVUE® DVC6000 Instrument Level HC, AD, PD, and ODV



Hot Key

- 1 Instrument Mode
- 2 Control Mode
- 3 Protection
- 4 Stabilize/Optimize

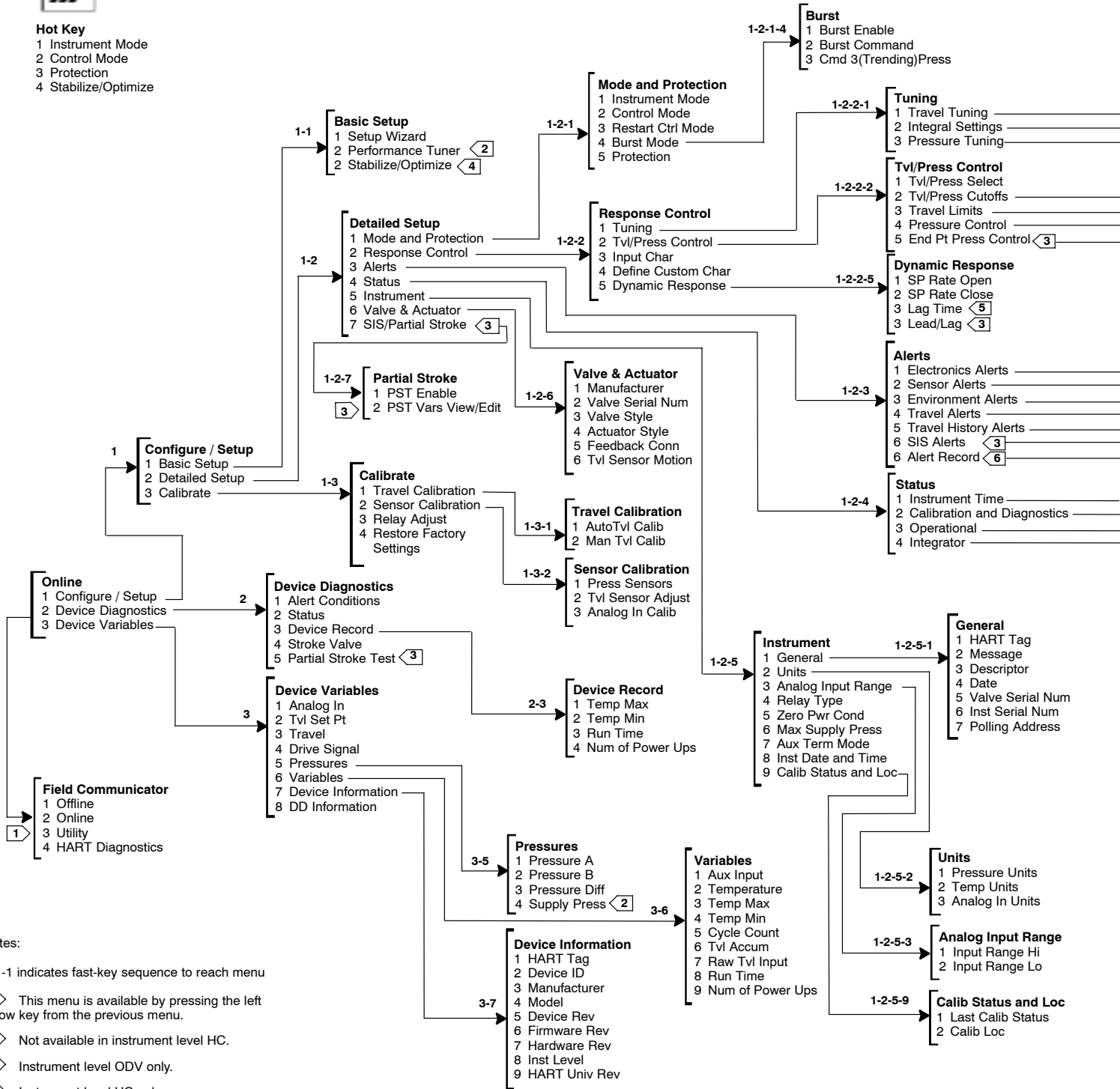

Notes:

1-1-1 indicates fast-key sequence to reach menu

- 1 This menu is available by pressing the left arrow key from the previous menu.
- 2 Not available in instrument level HC.
- 3 Instrument level ODV only.
- 4 Instrument level HC only.
- 5 Instrument level HC, AD, and PD only.
- 6 Fast key sequence for Alert Record with instrument level ODV is 1-2-3-7.

1

2

3

4

5

6

DVC6000 Series

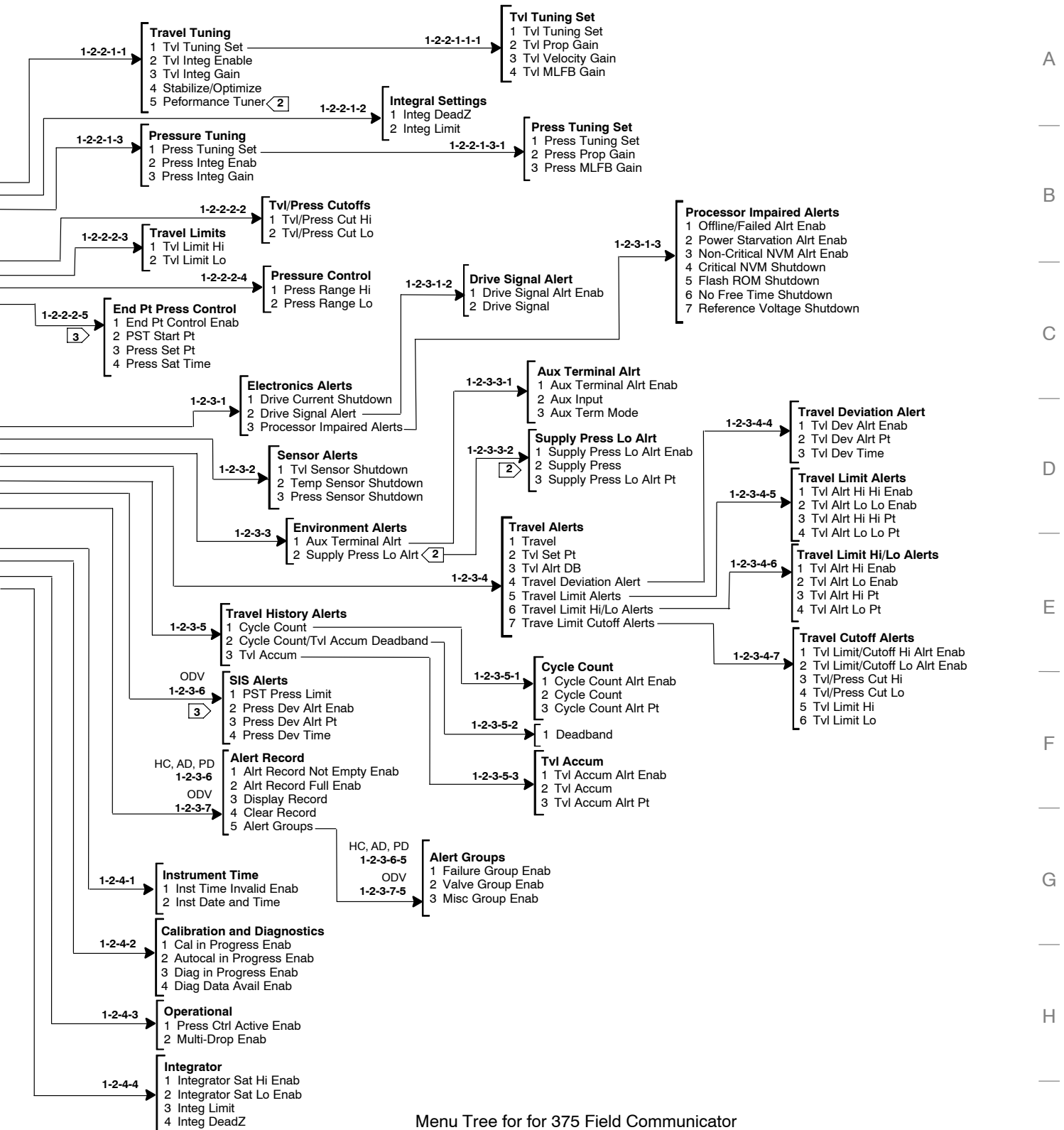

Menu Tree for for 375 Field Communicator
 Device Description Revision 1

DVC6000 Series

Fast-Key Sequence for Instrument Level HC, AD, PD, and ODV (continued)

Function/Variable	Fast-Key Sequence	Coordinates ⁽¹⁾	Function/Variable	Fast-Key Sequence	Coordinates ⁽¹⁾
Partial Stroke Test Variables View/Edit ⁽³⁾	1-2-7-2	3-D	Temperature Sensor Shutdown	1-2-3-2-2	9-D
Performance Tuner ⁽²⁾	1-1-2	2-B	Temperature Units	1-2-5-2-2	6-G
	1-2-2-1-1-5	8-A	Travel	3-3	2-F
Polling Address	1-2-5-1-7	6-F		1-2-3-4-1	10-E
Power Starvation Alert Enable	1-2-3-1-3-2	11-B	Travel / Pressure Cutoff Hi	1-2-3-4-7-3	12-F
Pressure A	3-5-1	4-G		1-2-2-2-2-1	9-B
Pressure B	3-5-2	4-G	Travel / Pressure Cutoff Lo	1-2-3-4-7-4	12-F
Pressure Control Active Enable	1-2-4-3-1	8-H		1-2-2-2-2-2	9-B
Pressure Deviation Alert Enable ⁽³⁾	1-2-3-6-2	8-F	Travel / Pressure Select	1-2-2-2-1	6-B
Pressure Deviation Alert Point ⁽³⁾	1-2-3-6-3	8-F	Travel Accumulator	3-6-6	5-H
Pressure Deviation Time ⁽³⁾	1-2-3-6-4	8-F		1-2-3-5-3-2	10-F
Pressure Differential	3-5-3	4-G	Travel Accumulator Alert Enable	1-2-3-5-3-1	10-F
Pressure Integral Control Enable	1-2-2-1-3-2	8-B	Travel Accumulator Alert Point	1-2-3-5-3-3	10-F
Pressure Integral Gain	1-2-2-1-3-3	8-B	Travel Alert Dead Band	1-2-3-4-3	10-E
Pressure MLFB Gain	1-2-2-1-3-1-3	10-B	Travel Alert Hi Enable	1-2-3-4-6-1	12-E
Pressure Proportional Gain	1-2-2-1-3-1-2	10-B	Travel Alert Hi Hi Enable	1-2-3-4-5-1	12-D
Pressure Range Hi	1-2-2-2-4-1	9-C	Travel Alert Hi Hi Point	1-2-3-4-5-3	12-D
Pressure Range Lo	1-2-2-2-4-2	9-C	Travel Alert Hi Point	1-2-3-4-6-3	12-E
Pressure Sat Time ⁽³⁾	1-2-2-2-5-4	8-C	Travel Alert Lo Enable	1-2-3-4-6-2	12-E
Pressure Sensor Shutdown ⁽²⁾	1-2-3-2-3	9-D	Travel Alert Lo Lo Enable	1-2-3-4-5-2	12-D
Pressure Sensors—Calibration	1-3-2-1	4-E	Travel Alert Lo Lo Point	1-2-3-4-5-4	12-D
Pressure Set Point ⁽³⁾	1-2-2-2-5-3	8-C	Travel Alert Lo Point	1-2-3-4-6-4	12-E
Pressure Tuning Set	1-2-2-1-3-1-1	10-B	Travel Deviation Alert Enable	1-2-3-4-4-1	12-D
Pressure Units	1-2-5-2-1	6-G	Travel Deviation Alert Point	1-2-3-4-4-2	12-D
Protection	Hot Key-3	1-A	Travel Deviation Time	1-2-3-4-4-3	12-D
	1-2-1-5	4-B	Travel Integral Control Enable	1-2-2-1-1-2	8-A
Raw Travel Input	3-6-7	5-H	Travel Integral Gain	1-2-2-1-1-3	8-A
Reference Voltage Shutdown	1-2-3-1-3-7	11-C	Travel Limit / Cutoff Hi Alert Enable	1-2-3-4-7-1	12-E
Relay Adjust	1-3-3	3-E	Travel Limit / Cutoff Lo Alert Enable	1-2-3-4-7-2	12-E
Relay Type	1-2-5-4	5-F	Travel Limit Hi	1-2-3-4-7-5	12-F
Restart Control Mode	1-2-1-3	4-B		1-2-2-2-3-1	8-B
Restore Factory Settings	1-3-4	3-E	Travel Limit Lo	1-2-3-4-7-6	12-F
Run Time	2-3-3	4-F		1-2-2-2-3-2	8-B
	3-6-8	5-H	Travel MLFB Gain	1-2-2-1-1-1-4	10-A
Set Point Rate Close	1-2-2-5-2	6-C	Travel Proportional Gain	1-2-2-1-1-1-2	10-A
Set Point Rate Open	1-2-2-5-1	6-C	Travel Sensor Adjust	1-3-2-2	4-E
Setup Wizard	1-1-1	2-B	Travel Sensor Motion	1-2-6-6	4-D
Stabilize/Optimize	Hot Key-4	1-A	Travel Sensor Shutdown	1-2-3-2-1	9-D
	1-1-2 ⁽⁴⁾	2-B	Travel Set Point	1-2-3-4-2	10-E
	1-2-2-1-1-4	8-A		3-2	2-F
Status	2-2	2-E	Travel Tuning Set	1-2-2-1-1-1-1	10-A
Stroke Valve	2-4	2-F	Travel Velocity Gain	1-2-2-1-1-1-3	10-A
Supply Pressure ⁽²⁾	3-5-4	4-G	Valve Group Enable	1-2-3-6-5-2	10-G
	1-2-3-3-2-2	10-D		1-2-3-7-5-2	
Supply Pressure Lo Alert Enable	1-2-3-3-2-1	10-D	Valve Serial Number	1-2-5-1-5	6-F
Supply Pressure Lo Alert Point	1-2-3-3-2-3	10-D		1-2-6-2	4-D
Temperature	3-6-2	5-G	Valve Style	1-2-6-3	4-D
Temperature Maximum	3-6-3	5-G	Zero Power Condition	1-2-5-5	5-F
	2-3-1	4-F			
Temperature Minimum	3-6-4	5-H			
	2-3-2	4-F			

NOTE: *Italicized Fast-Key Sequence* indicates fast-key sequence is applicable only for instrument level ODV.

1. Coordinates are to help locate the item on the foldout menu tree.

2. Not available in instrument level HC.

3. Instrument level ODV only.

4. Instrument level HC only.

5. Instrument level HC, AD, and PD only.

DVC6000 Series

Fast-Key Sequence for Instrument Level AC

Function/Variable	Fast-Key Sequence	Coordinates ⁽¹⁾	Function/Variable	Fast-Key Sequence	Coordinates ⁽¹⁾
Actuator Style	1-1-2-2-4	5-C	Pressure Proportional Gain	1-1-2-3-2-2	6-D
Analog Input Calibration	1-3-1	3-F		1-2-3-4-1-2	6-G
Analog Input Range Hi	1-2-2-2	4-E	Pressure Range Hi	1-2-3-5-1	5-G
Analog Input Range Lo	1-2-2-3	4-E	Pressure Range Lo	1-2-3-5-2	5-G
Analog Input Units	1-2-2-1	4-E	Pressure Tuning Set	1-1-2-3-2-1	6-D
Auto Travel Calibration	1-1-2-3-4	5-D		1-2-3-4-1-1	6-G
	1-3-2	3-F	Pressure Units	1-1-2-2-2	5-C
	1-1-1-3	5-D		1-2-2-4	4-E
Calibration Location	1-3-5	3-F	Protection	Hot Key-2	1-B
Date	1-2-1-4	4-D	Relay Adjust	1-1-1-2	4-B
Descriptor	1-2-1-3	4-D		1-1-2-3-3	5-D
Device Description Revision	2-2	2-F		1-3-6	3-G
Device Identification	2-1-6	3-G	Relay Type	1-2-4	3-D
Device Revision	2-1-2	3-G	Restore Factory Settings	1-3-4	3-F
Feedback Connection	1-1-2-2-5	5-C	Setup Wizard	1-1-1-1	4-B
Firmware Revision	2-1-3	3-G	Travel Integral Gain	1-2-3-2-3	5-E
Hardware Revision	2-1-4	3-G	Travel Integral Enable	1-2-3-2-2	5-E
HART Tag	1-2-1-1	4-D	Travel MLFB Gain	1-1-2-3-1-4	6-D
HART Universal Revision	2-1-1	3-G		1-2-3-2-1-4	6-E
Input Characterization	1-2-3-6	4-F	Travel / Pressure Select	1-1-2-2-1	5-C
Instrument Level	2-1-5	3-G		1-2-3-1	4-F
Instrument Mode	Hot Key-1	1-B	Travel Proportional Gain	1-1-2-3-1-2	6-D
	1-1-2-1	4-C		1-2-3-2-1-2	6-E
Instrument Serial Number	1-2-1-6	4-E	Travel Sensor Adjust	1-3-7	3-G
Integral Dead Zone	1-2-3-3-1	5-F	Travel Sensor Motion	1-1-2-2-6	5-C
Integral Limit	1-2-3-3-2	5-F	Travel Tuning Set	1-1-2-3-1-1	6-D
Manual Travel Calibration	1-3-3	3-F		1-2-3-2-1-1	6-E
Maximum Supply Pressure	1-1-2-2-3	5-C	Travel Velocity Gain	1-1-2-3-1-3	6-D
Message	1-2-1-2	4-D		1-2-3-2-1-3	6-E
Polling Address	1-2-1-7	4-E	Valve Serial Number	1-2-1-5	4-D
Pressure Integral Control Enable	1-2-3-4-2	5-F	Valve Style	1-1-2-2-7	5-C
Pressure Integral Gain	1-2-3-4-3	5-F	Zero Power Condition	1-1-2-2-8	5-C
Pressure MLFB Gain	1-1-2-3-2-3	6-D			
	1-2-3-4-1-3	6-G			

1. Coordinates are to help locate the item on the menu tree on the facing page.

375 Field Communicator Menu Tree for FIELDVUE® DVC6000 AC Level

A

B

C

D

E

F

G

H

I



Hot Key

- 1 Instrument Mode
- 2 Protection

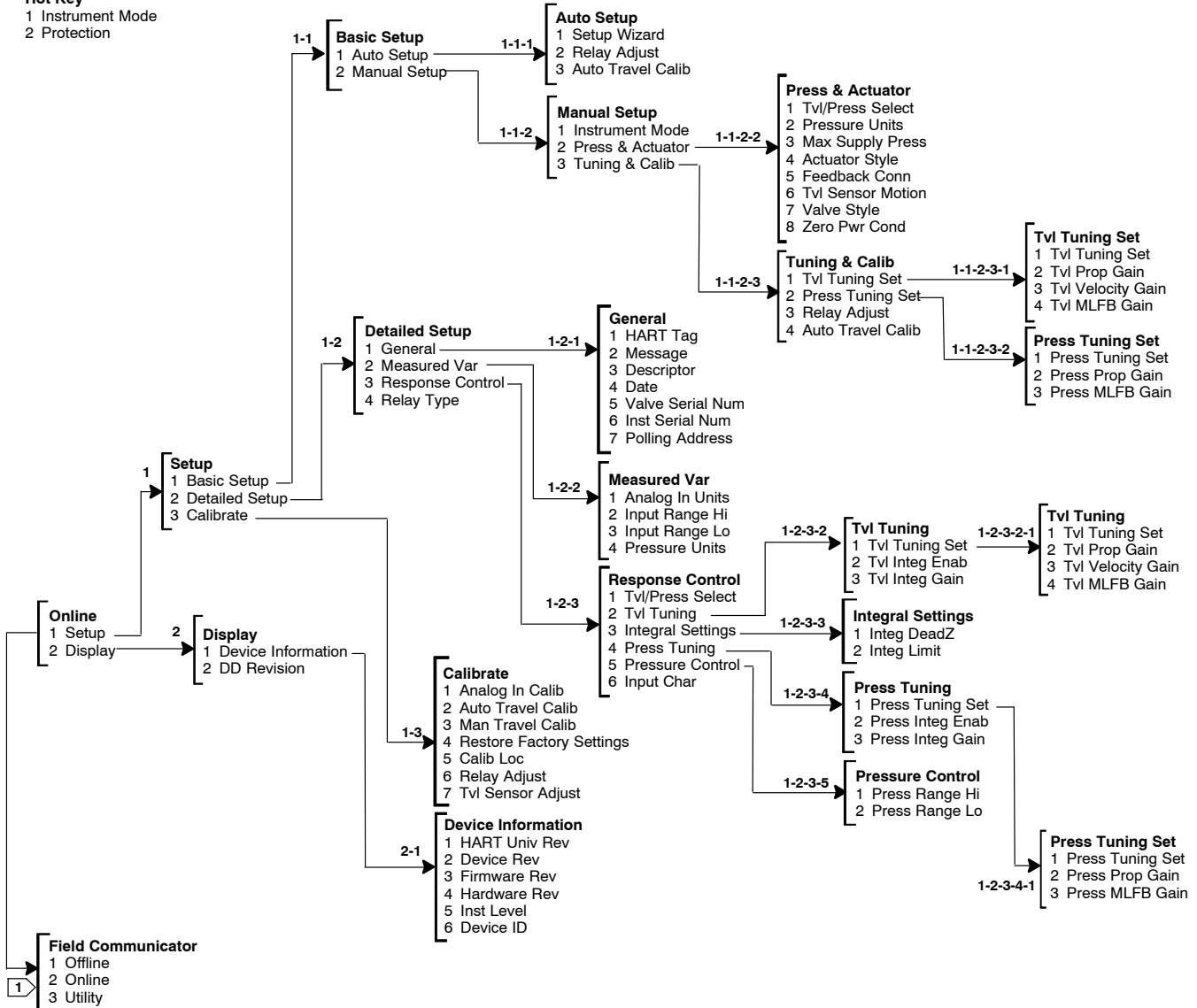

Notes:

1-1-1 indicates fast-key sequence to reach menu

1 This menu is available by pressing the left arrow key from the previous menu.

Menu Tree for 375 Field Communicator
Device Description Revision 1

DVC6000 Series



THE FIELDVUE® DVC6000 SERIES DIGITAL VALVE CONTROLLER IS A CORE COMPONENT OF THE PLANTWEB® DIGITAL PLANT ARCHITECTURE. THE DIGITAL VALVE CONTROLLER POWERS PLANTWEB BY CAPTURING AND DELIVERING VALVE DIAGNOSTIC DATA. COUPLED WITH AMS™ VALVELINK® SOFTWARE, THE DVC6000 PROVIDES USERS WITH AN ACCURATE PICTURE OF VALVE PERFORMANCE, INCLUDING ACTUAL STEM POSITION, INSTRUMENT INPUT SIGNAL AND PNEUMATIC PRESSURE TO THE ACTUATOR. USING THIS INFORMATION, THE DIGITAL VALVE CONTROLLER DIAGNOSES NOT ONLY ITSELF, BUT ALSO THE VALVE AND ACTUATOR TO WHICH IT IS MOUNTED.

FIELDVUE® DVC6000 Series Digital Valve Controller



Figure 1-1. Type DVC6010 Digital Valve Controller Mounted on a Sliding-Stem Valve Actuator



Figure 1-2. Rotary Control Valve with Type DVC6020 Digital Valve Controller

to a pneumatic output pressure, the DVC6000 Series digital valve controllers communicate via HART protocol.

DVC6000 Series digital valve controllers are designed to directly replace standard pneumatic and electro-pneumatic valve mounted positioners.



Note

Do not install, operate, or maintain a DVC6000 Series digital valve controller without first • being fully trained and qualified in valve, actuator and accessory installation, operation and maintenance, and • carefully reading and understanding the contents of this manual. If you have any questions regarding these instructions, contact your Emerson Process Management sales office before proceeding.

Use of this Guide

This guide describes how to install, setup, and calibrate DVC6000 Series digital valve controllers. Additional information for installing, operating, and maintaining the DVC6000 Series digital valve controllers can be found in the related documents listed on page 4-6. Refer to table 1-1 for details on the capabilities of each diagnostic tier.

This guide describes instrument setup and calibration using a 375 Field Communicator. For information on using the 375 Field Communicator, see the Product Manual for the Field Communicator available from Emerson Process Management. An abbreviated description of Field Communicator operation is also contained in the FIELDVUE instrument instruction manual.

You can also setup and calibrate the instrument using a personal computer and AMS™ ValveLink® Software or AMS Suite: Intelligent Device Manager. For information on using AMS ValveLink Software or AMS Device Manager with a FIELDVUE instrument, refer to the appropriate documentation or online help.

Product Description

DVC6000 Series digital valve controllers (figures 1-1 and 1-2) are communicating, microprocessor-based current-to-pneumatic instruments. In addition to the traditional function of converting an input current signal

DVC6000 Series

Table 1-1. Instrument Level Capabilities

CAPABILITY	DIAGNOSTIC LEVEL				
	AC	HC	AD	PD	ODV
Auto Calibration	X	X	X	X	X
Burst Communication		X	X	X	X
Custom Characterization	X	X	X	X	X
Alerts		X	X	X	X
Step Response, Drive Signal Test & Dynamic Error Band			X	X	X
Advanced Diagnostics (Valve Signature)			X	X	X
Performance Tuner			X	X	X
Travel Control – Pressure Fallback			X	X	X
Performance Diagnostics				X	X
Solenoid Valve Testing				X	X
Lead/Lag Input Filter ⁽¹⁾					X

1. Refer to brochure part # D351146X012/D351146X412 for information on Fisher[®] optimized digital valves for compressor antisurge applications.

1

Displaying the Field Communicator Device Description Revision Number

Device Description (DD) revision identifies the version of the Fisher[®] Device Description that resides in the Field Communicator. The device description defines how the Field Communicator interacts with the user and instrument. You can display the DD revision from the Offline or Online menu.

Offline Menu—To see the Field Communicator device description revision number from the Offline menu, select *Utility, Simulation, Fisher Controls,* and *DVC6000.*

Online Menu—To see the Field Communicator device description revision number from the Online menu, connect the Field Communicator to an instrument connected to a source supplying a 4 to 20 mA signal. From the Online menu, select *Device Variables* and *DD Information.*

Displaying the FIELDVUE[®] Instrument Firmware Revision Number

To view the instrument firmware revision, connect the Field Communicator to an instrument connected to a source supplying a 4 to 20 mA signal. From the Online menu, select *Device Variables, Device Information,* and *Firmware Rev.*



Note

Neither Emerson, Emerson Process Management, nor any of their affiliated entities assumes responsibility for the selection, use, and maintenance of any product. Responsibility for the selection, use, and maintenance of any product remains with the purchaser and end-user.

Installation

The DVC6000 can be used with either air or natural gas as the supply medium. If using natural gas as the pneumatic supply medium, natural gas will be used in the pneumatic output connections of the DVC6000 to any connected equipment. In normal operation the unit will vent the supply medium into the surrounding atmosphere unless it is remotely vented. When using natural gas as the supply medium, in a non-hazardous location in a confined area, remote venting of the unit is required. Failure to do so could result in personal injury, property damage, and area re-classification. For hazardous locations remote venting of the unit may be required, depending upon the area classification, and as specified by the requirements of local, regional, and federal codes, rules and regulations. Failure to do so when necessary could result in personal injury, property damage, and area re-classification.



Note

The DVC6000 is suitable for use with natural gas, however, CSA, FM, ATEX, and IECEx gas approvals are pending. Contact your Emerson Process Management sales office for information on pending approvals.

WARNING

Avoid personal injury or property damage from sudden release of process pressure or bursting of parts. Before proceeding with any installation procedures:

- Always wear protective clothing, gloves, and eyewear to prevent personal injury.
- Personal injury or property damage may result from fire or explosion if natural gas is used as the supply medium and preventive measures are not taken. Preventive measures may include: Remote

venting of the unit, re-evaluating the hazardous area classification, ensuring adequate ventilation, and the removal of any ignition sources. For information on remote venting of this controller, refer to page 2-12.

- **Disconnect any operating lines providing air pressure, electric power, or a control signal to the actuator. Be sure the actuator cannot suddenly open or close the valve.**

- **Use bypass valves or completely shut off the process to isolate the valve from process pressure. Relieve process pressure from both sides of the valve.**

- **Vent the pneumatic actuator loading pressure and relieve any actuator spring precompression.**

- **Use lock-out procedures to be sure that the above measures stay in effect while you work on the equipment.**

- **Check with your process or safety engineer for any additional measures that must be taken to protect against process media.**

WARNING

To avoid static discharge from the plastic cover, do not rub or clean the cover with solvents. To do so could result in an explosion. Clean with a mild detergent and water only.

WARNING

This unit vents the supply medium into the surrounding atmosphere. When installing this unit in a non-hazardous (non-classified) location in a confined area, with natural gas as the supply medium, you must remotely vent this unit to a safe location. Failure to do so could result in personal injury or property damage from fire or explosion, and area re-classification.

When installing this unit in a hazardous (classified) location remote venting of the unit may be required, depending upon the area classification, and as specified by the requirements of local, regional, and federal codes, rules and regulations. Failure to do so when necessary could result in personal injury or property damage from fire or explosion, and area re-classification.

Vent line piping should comply with local and regional codes and should be as short as possible with adequate inside diameter and few bends to reduce case pressure buildup.

In addition to remote venting of the unit, ensure that all caps and covers are correctly installed. Failure to do so could result in personal injury or property damage from fire or explosion, and area re-classification.

Special Instructions for Safe Use and Installations in Hazardous Locations

Certain nameplates may carry more than one approval, and each approval may have unique installation requirements and/or conditions of safe use. Special instructions are listed by agency/approval.

After reading and understanding these special conditions of use, proceed with standard installation procedures.

WARNING

Failure to follow these conditions of safe use could result in personal injury or property damage from fire or explosion, or area re-classification.

CSA

Special Conditions of Safe Use

No special conditions for safe use.

Refer to table 4-3 for approval information, figure 5-1 for the CSA loop schematic, and figure 5-2 for the CSA nameplate.

FM

Special Conditions of Safe Use

No special conditions for safe use.

Refer to table 4-3 for approval information, figure 5-3 for the FM loop schematic, and figure 5-4 for the FM nameplate.

ATEX Intrinsic Safety, Dust

Special Conditions for Safe Use

1. This apparatus can only be connected to an intrinsically safe certified equipment and this combination must be compatible as regards the intrinsically safe rules.

2. The electrical parameters of this equipment must not exceed any following values:

$U_0 \leq 30 \text{ V}$; $I_0 \leq 226 \text{ mA}$; $P_0 \leq 1.4 \text{ W}$

3. Operating ambient temperature: -52°C or -40°C to $+80^\circ\text{C}$

Refer to table 4-4 for additional approval information, and figure 5-5 for the the ATEX Intrinsic Safety, Dust nameplate.

ATEX Flameproof, Dust

Special Conditions for Safe Use

Operating ambient temperature: -52°C or -40°C to $+85^\circ\text{C}$

Refer to table 4-4 for additional approval information, and figure 5-6 for the ATEX Flameproof, Dust nameplate.

ATEX Type n, Dust

Special Conditions for Safe Use

Operating ambient temperature: -52°C or -40°C to $+80^{\circ}\text{C}$

Refer to table 4-4 for additional approval information, and figure 5-7 for the ATEX Type n, Dust nameplate.

IECEx Intrinsic Safety, Type n, Flameproof

Conditions of Certification

Ex ia / Ex d / Ex n

1. **Warning:** Electrostatic charge hazard. Do not rub or clean with solvents. To do so could result in an explosion.

EX d / Ex n

2. Do not open while energized.

Refer to table 4-4 for additional approval information, and figure 5-8 for the IECEx nameplate.

NEPSI Intrinsic Safety, Dust and Flameproof, Dust

Notes for Safe Use of the Certified Product

DVC6000 Series digital valve controllers (designated as controller hereafter) have been proved to be in conformity with the requirements specified in the national standards GB3836.1-2000, GB3836.2-2000, GB3836.4-2000, and GB12476.1-2000 through inspections conducted by National Supervision and Inspection Centre for Explosion Protection and Safety of Instrumentation (NEPSI). The Ex markings for the products are Ex d II CT5 (acetylene not included), DIPA21T5 or Ex ia II CT5, DIPA21T5 respectively and their Ex certificate numbers are GYJ04504 and GYJ04505. When using the product, the user should pay attention to the items stated below:

1. The specific product types of approved DVC6000 Series digital valve controllers this time are DVC6010, DVC6020 and DVC6030.
2. The enclosure of the controller provides a grounding terminal, and the user should install a reliable grounding wire connected to it when mounting and using the controller.
3. The controller's cable entrance (1/2 NPT) must be fitted with a cable entry device which is Ex-approved through inspection of explosion protection, in conformity with relevant standards of GB3836 and has a corresponding rating of explosion protection.
4. The maximum operating ambient temperature range of the controller is -40°C to $+80^{\circ}\text{C}$.

5. The principle of "Opening equipment's cover is allowed only after the power is off" must be abided by when using and maintaining the controller in the field.

6. The values for intrinsically safe parameters of the controller (Intrinsically safe type) are as follow:
 $U_i = 30\text{V}$, $I_i = 226\text{mA}$, $P_i = 1.4\text{W}$, $C_i = 5\text{nF}$,
 $L_i = 0.55\text{mH}$

7. While the controller forms an intrinsically safe explosion protection system together with a corresponding associated equipment safety barrier, the following requirements must be met:

$$U_o \leq U_i, I_o \leq I_i, P_o \leq P_i, C_o \geq C_i + C_c, \\ L_o \geq L_i + L_c$$

Note

Where C_c and L_c represent distributing capacitance and inductance of the connecting cable respectively.

8. The safety barrier must be placed at safety location, and the instruction manuals of both the product and fitted safety barrier must be followed while conducting system wiring and using the product; The connecting cable should be a shield cable with the area of core section being greater than 0.5mm^2 and its shield (or insulation screen) being grounded at a safe location and insulated from the product enclosure; The cable should be routed so that the electro-magnetic interference can be eliminated as much as possible and that the cable distributing parameters of capacitance and inductance can be controlled within $0.06\mu\text{F}/1\text{mH}$.

9. The user must not be allowed to replace the internal electric components of the product and change the condition of system wiring at will and on his own.

10. The user must follow the relevant rules specified by the product instruction manual, the "15th Section of Electric Equipment Used in Explosive Gaseous Environment: Electric Installation in Hazardous Locations (except for coal mine)" of GB3836.15-2000 standard, the "Design Code for Electric Power Installation in Explosive and Fire-hazardous Environment" of GB50058-1992 standard, and the "Safety Regulations against dust explosion" of GB15577-1995 standard while performing installation, operation, and maintenance for the product.

Refer to table 4-6 for additional approval information, and figure 5-9 for the NEPSI approvals nameplate.

INMETRO

Special Conditions of Safe Use

Refer to table 4-7 for approval information.

Contact your Emerson Process Management sales office for additional safe use information.

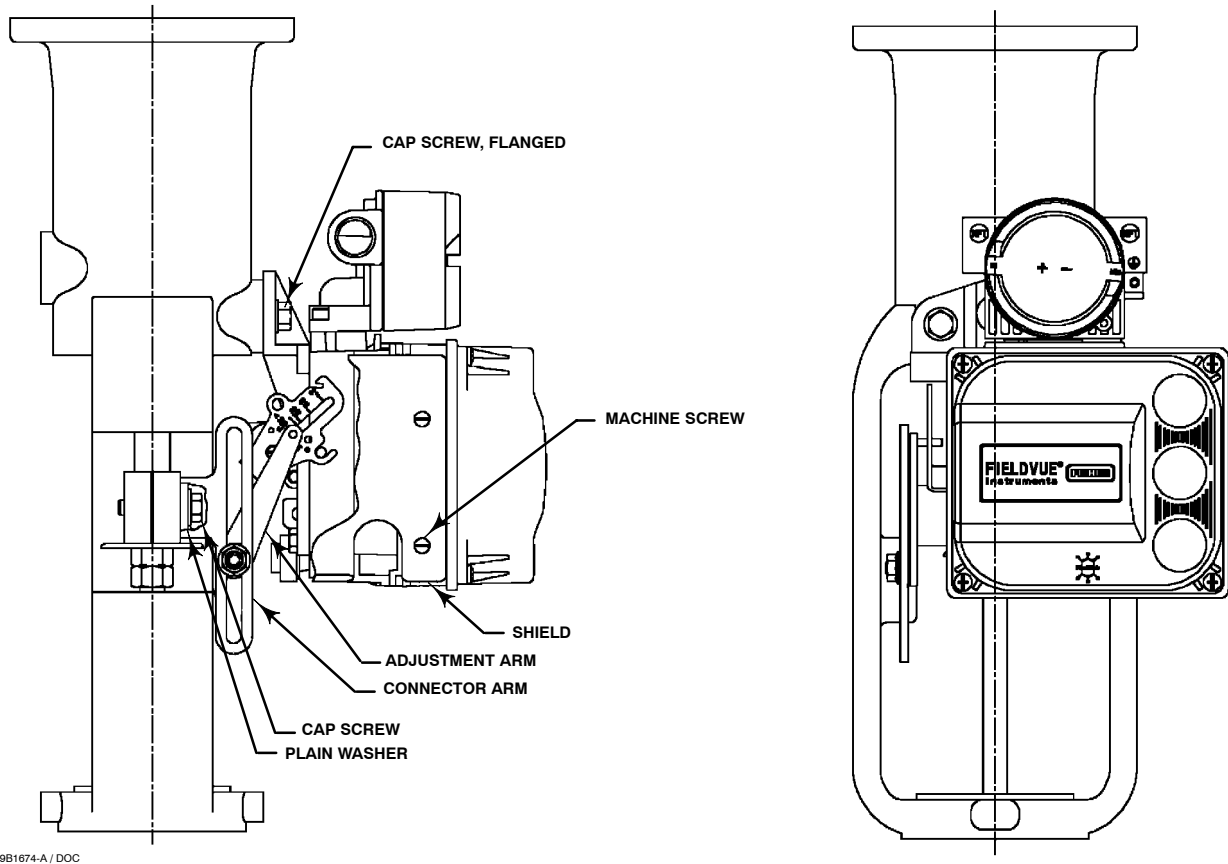

29B1674-A / DOC

Figure 2-1. DVC6010 Digital Valve Controller Mounted on Sliding-Stem Actuators with up to 2 Inches Travel

Mounting Standard DVC6000 Series Digital Valve Controllers

If ordered as part of a control valve assembly, the factory mounts the digital valve controller on the actuator, makes pneumatic connections to the actuator, sets up, and calibrates the instrument. If you purchased the digital valve controller separately, you will need a mounting kit to mount the digital valve controller on the actuator. See the instructions that come with the mounting kit for detailed information on mounting the digital valve controller to a specific actuator model.

Guidelines for Mounting DVC6010 on Sliding-Stem Actuators Up to 102 mm (4 Inches) of Travel

WARNING

Observe the Installation **WARNING** at the beginning of this section.

The Type DVC6010 digital valve controller mounts on sliding-stem actuators with up to 102 mm (4-inch) travel. Figure 2-1 shows a typical mounting on an actuator with up to 51 mm (2-inch) travel. Figure 2-2 shows a typical mounting on actuators with 51 to 102 mm (2- to 4-inch) travel. For actuators with greater than 102 mm (4-inch) travel, see the guidelines for mounting a DVC6020 digital valve controller.



Note

Do not use the stainless steel DVC6010S in high vibration service where the mounting bracket uses standoffs (spacers) to mount to the actuator.

Refer to the following guidelines when mounting on sliding-stem actuators with up to 4 inches of travel.

1. Attach the connector arm to the valve stem connector.

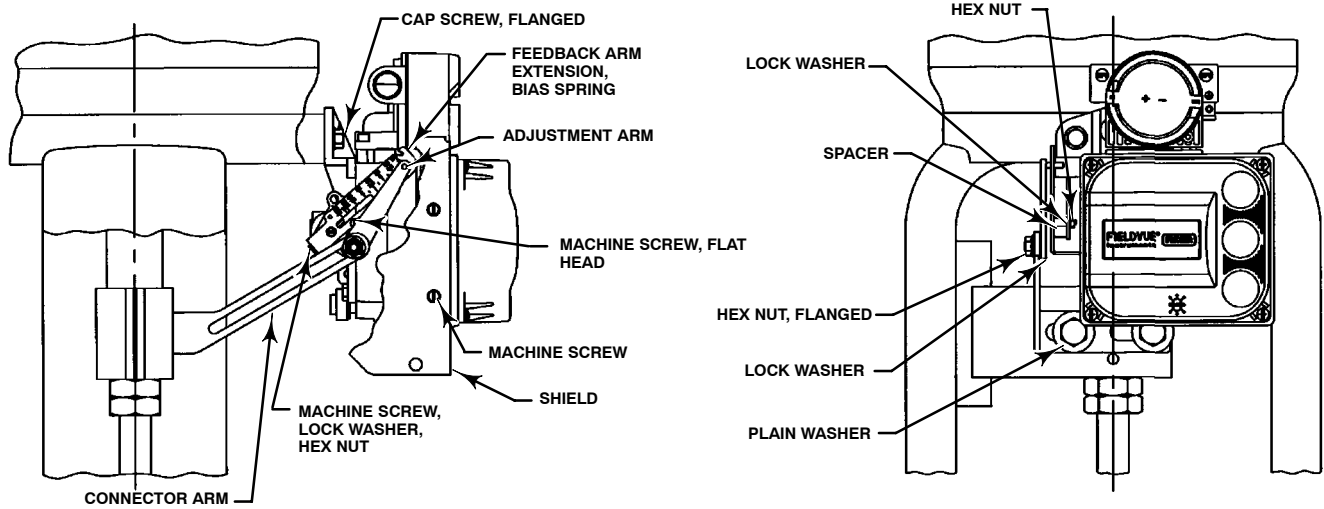
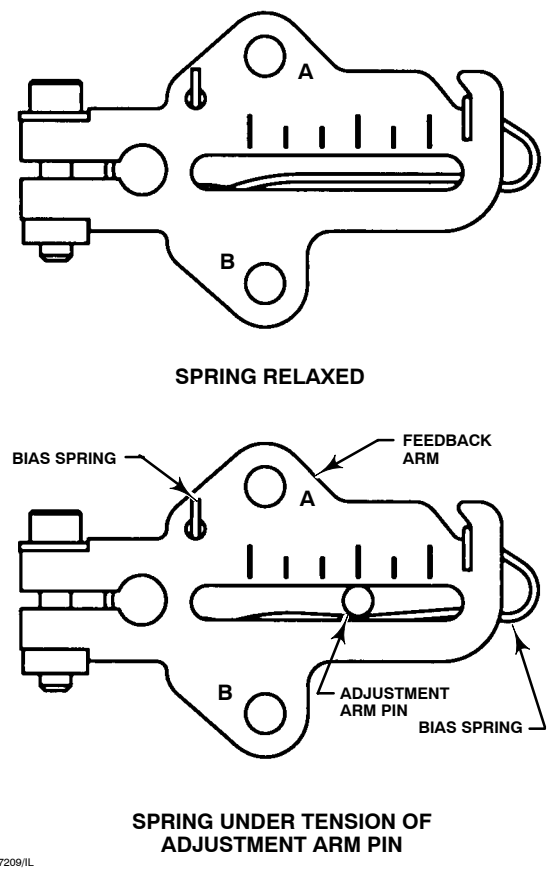

Figure 2-2. DVC6010 Digital Valve Controller Mounted on Sliding-Stem Actuators with 2 to 4 Inches Travel

2. Attach the mounting bracket to the digital valve controller housing.
3. If valve travel exceeds 2 inches, a feedback arm extension is attached to the existing 2-inch feedback arm. Remove the existing bias spring from the 2-inch feedback arm. Attach the feedback arm extension to the feedback arm as shown in figure 2-2.
4. Mount the digital valve controller on the actuator as described in the mounting kit instructions.
5. Set the position of the feedback arm on the digital valve controller to the no air position by inserting the alignment pin through the hole on the feedback arm as follows:

- **For air-to-open actuators** (i.e., the actuator stem retracts into the actuator casing or cylinder as air pressure to the casing or lower cylinder increases), insert the alignment pin into the hole marked "A". For this style actuator, the feedback arm rotates counterclockwise, from A to B, as air pressure to the casing or lower cylinder increases.

- **For air-to-close actuators** (i.e., the actuator stem extends from the actuator casing or cylinder as air pressure to the casing or upper cylinder increases), insert the alignment pin into the hole marked "B". For this style actuator, the feedback arm rotates clockwise, from B to A, as air pressure to the casing or upper cylinder increases.



A7209/IL

Figure 2-3. Locating Adjustment Arm Pin in Feedback Arm

DVC6000 Series



Note

When performing the following steps, ensure there is enough clearance between the adjustment arm and the feedback arm to prevent interference with the bias spring.

2

6. Apply lubricant to the pin of the adjustment arm. As shown in figure 2-3, place the pin into the slot of the feedback arm or feedback arm extension so that the bias spring loads the pin against the side of the arm with the valve travel markings.

7. Install the external lock washer on the adjustment arm. Position the adjustment arm in the slot of the connector arm and loosely install the flanged hex nut.

8. Slide the adjustment arm pin in the slot of the connector arm until the pin is in line with the desired valve travel marking. Tighten the flanged hex nut.

9. Remove the alignment pin and store it in the module base next to the I/P assembly.

10. After calibrating the instrument, attach the shield with two machine screws.

Guidelines for Mounting DVC6020 Sliding-Stem Actuators and Rotary Actuators



WARNING

Observe the Installation WARNING at the beginning of this section.

Type DVC6020 digital valve controllers use a cam (designed for linear response) and roller as the feedback mechanism. Figure 2-4 shows the DVC6020 mounted on rotary actuators.



Note

All cams supplied with FIELDVUE mounting kits are characterized to provide a linear response.



Note

Do not use the stainless steel DVC6020S in high vibration service where the mounting bracket uses standoffs (spacers) to mount to the actuator.

As shown in figure 2-4, two feedback arms are available for the digital valve controller. Installations on Fisher Type 1051 size 33 and Type 1052 size 20 and 33 actuators use the short feedback arm [54 mm (2.13 inches) from roller to pivot point]. Most other use the long feedback arm. Make sure the correct feedback arm is installed on the digital valve controller before beginning the mounting procedure.

Refer to figure 2-4 for parts locations. Refer to the following guidelines when mounting on rotary actuators:

1. If a cam is not already installed on the actuator, install the cam as described in the instructions included with the mounting kit.
2. If a mounting plate is required, fasten the mounting plate to the actuator.
3. For applications that require remote venting, a pipe-away bracket kit is available. Follow the instructions included with the kit to replace the existing mounting bracket on the digital valve controller with the pipe-away bracket and to transfer the feedback parts from the existing mounting bracket to the pipe-away bracket.
4. Mount the DVC6020 on the actuator as follows:

- If required, a mounting adaptor is included in the mounting kit. Attach the adaptor to the actuator as shown in figure 2-4. Then attach the digital valve controller assembly to the adaptor. The roller on the digital valve controller feedback arm will contact the actuator cam as it is being attached.

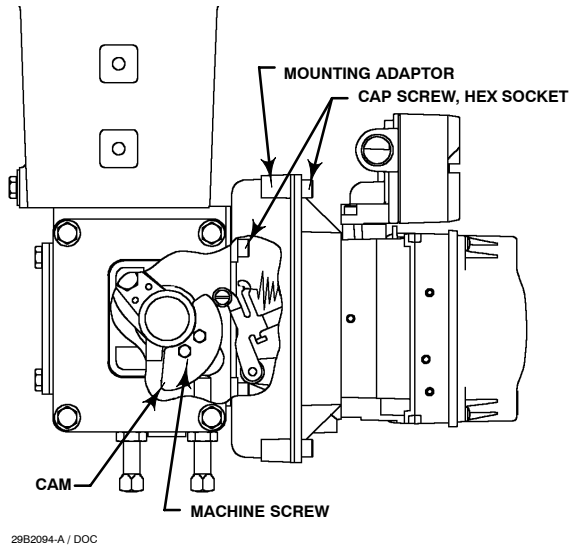

**TYPICAL MOUNTING WITH SHORT FEEDBACK ARM
(FISHER TYPE 1052 SIZE 33 ACTUATOR SHOWN)**

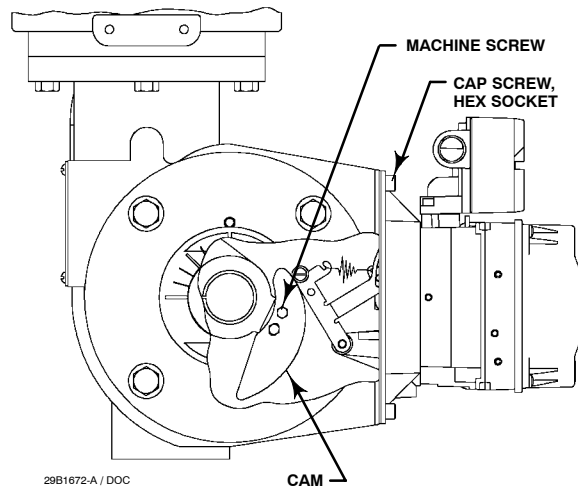

**TYPICAL MOUNTING WITH LONG FEEDBACK ARM
(FISHER TYPE 1061 SIZE 30-68 ACTUATOR SHOWN)**

Figure 2-4. DVC6020 Digital Valve Controller Mounted on Rotary Actuators

- If no mounting adaptor is required, attach the digital valve controller assembly to the actuator or mounting plate. The roller on the digital valve controller feedback arm will contact the actuator cam as it is being attached.

Guidelines for Mounting DVC6030 on Quarter-Turn Actuators

WARNING

Observe the Installation WARNING at the beginning of this section.

Figure 2-5 shows the Type DVC6030 digital valve controller mounted on a quarter-turn actuator. Refer to figure 2-5 for parts locations. Refer to the following guidelines when mounting on quarter-turn actuators:



Note

Due to NAMUR mounting limitations, do not use the stainless steel DVC6030S in high vibration service.

1. If necessary, remove the existing hub from the actuator shaft.
 2. If a positioner plate is required, attach the positioner plate to the actuator as described in the mounting kit instructions.
 3. If required, attach the spacer to the actuator shaft.
- Refer to figures 2-6 and 2-7. The travel indicator assembly can have a starting position of 7:30 or 10:30. Determine the desired starting position then proceed with the next step. Considering the top of the digital valve controller as the 12 o'clock position, in the next step attach the travel indicator, so that the pin is positioned as follows:

- **If increasing pressure from the digital valve controller output A rotates the potentiometer shaft clockwise (as viewed from the back of the instrument), mount the travel indicator assembly so that the arrow is in the 10:30 position, as shown in figure 2-6.**

DVC6000 Series

2

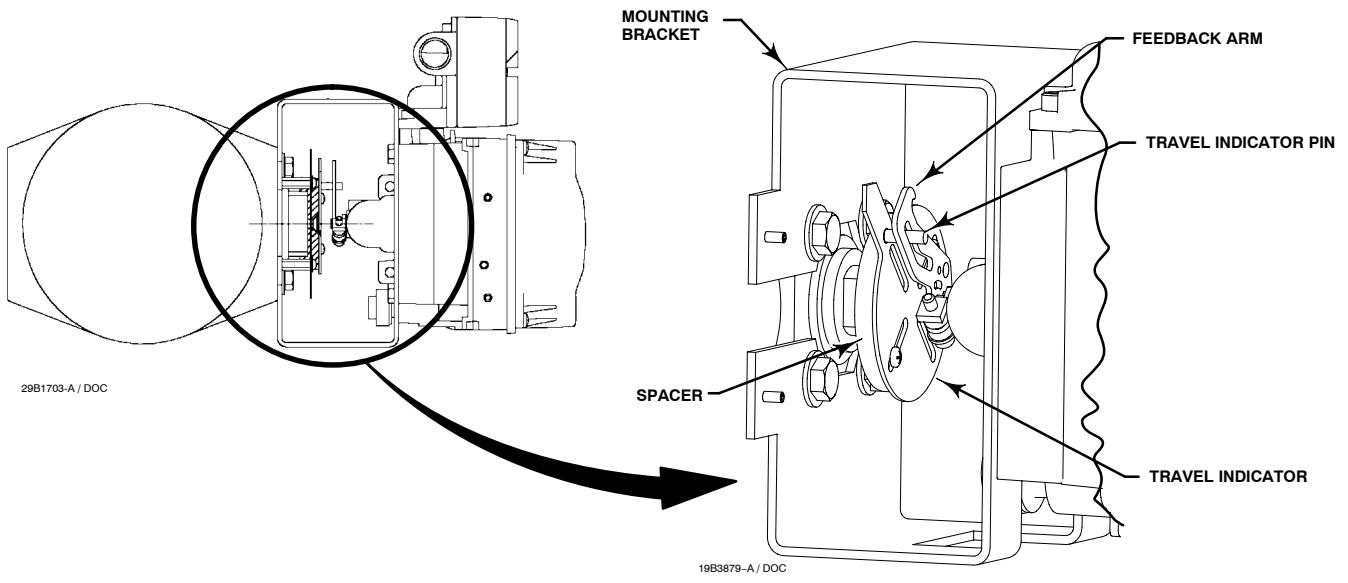

Figure 2-5. Mounting a DVC6030 Digital Valve Controller on a Rotary Actuator (Type 1032 Size 425A Shown)

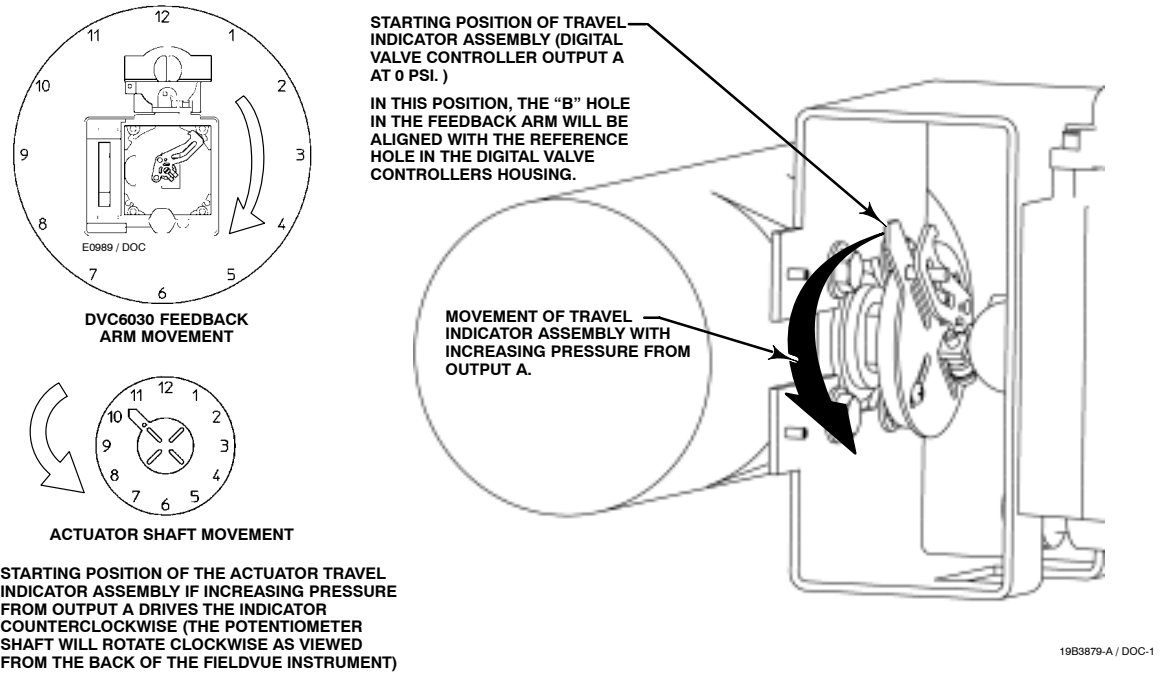

Figure 2-6. Explanation of Travel Indicator Starting Position and Movement, if **Clockwise** Orientation is Selected for "Travel Sensor Motion" in AMS™ ValveLink® Software or the 375 Field Communicator

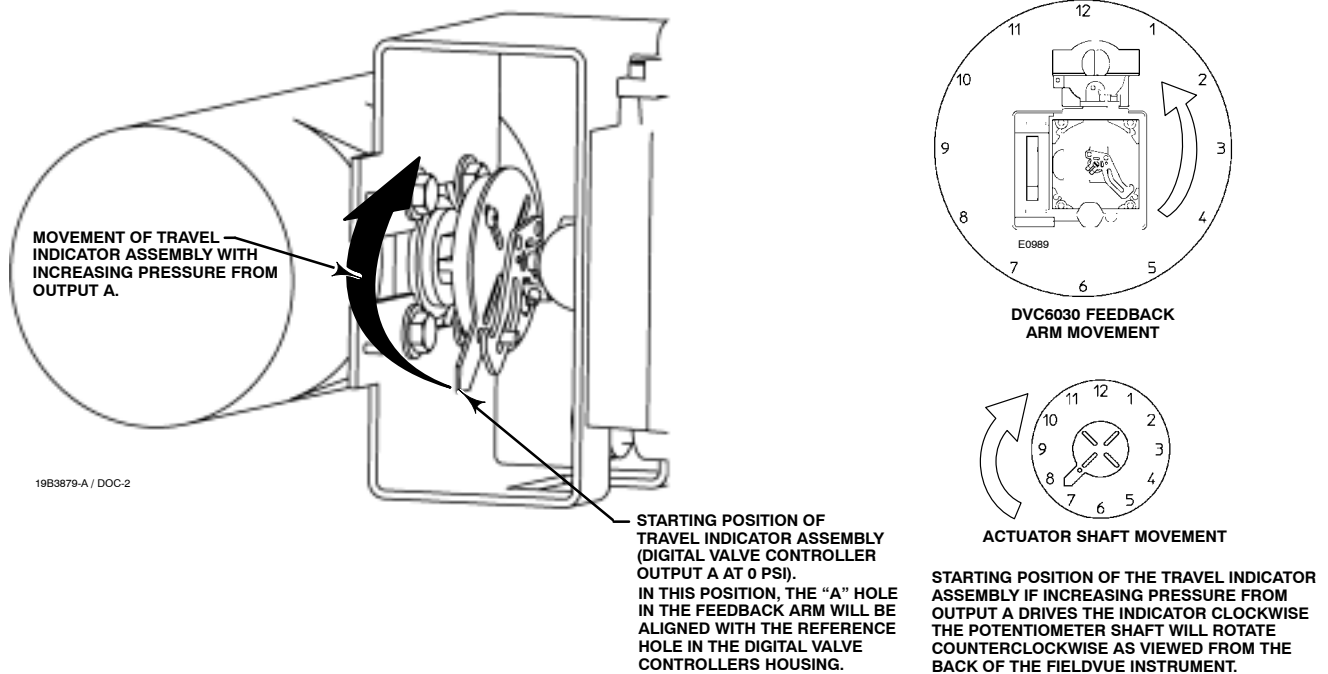

Figure 2-7. Explanation of Travel Indicator Starting Position and Movement if **Counterclockwise** Orientation is Selected for "Travel Sensor Motion" in AMS™ ValveLink® Software or the 375 Field Communicator

- If increasing pressure from the digital valve controller output A rotates the potentiometer shaft **counterclockwise** (as viewed from the back of the instrument), mount the travel indicator assembly so that the arrow is in the 7:30 position, as shown in figure 2-7.

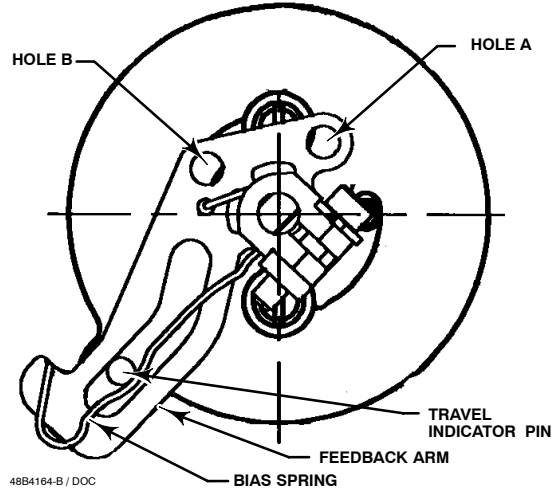

Figure 2-8. Positioning Travel Indicator Pin in the Feedback Arm (Viewed as if Looking from the DVC6030 toward the Actuator)



Note

AMS ValveLink Software and the 375 Field Communicator use the convention of clockwise (figure 2-6) and counterclockwise (figure 2-7) when viewing the potentiometer shaft from the back of the FIELDVUE instrument.

4. Attach the travel indicator to the shaft connector or spacer as described in the mounting kit instructions.
5. Attach the mounting bracket to the digital valve controller.
6. Position the digital valve controller so that the pin on the travel indicator, engages the slot in the

feedback arm and that the bias spring loads the pin as shown in figure 2-8. Attach the digital valve controller to the actuator or positioner plate.

7. If a travel indicator scale is included in the mounting kit, attach the scale as described in the mounting kit instructions.

DVC6000 Series

2

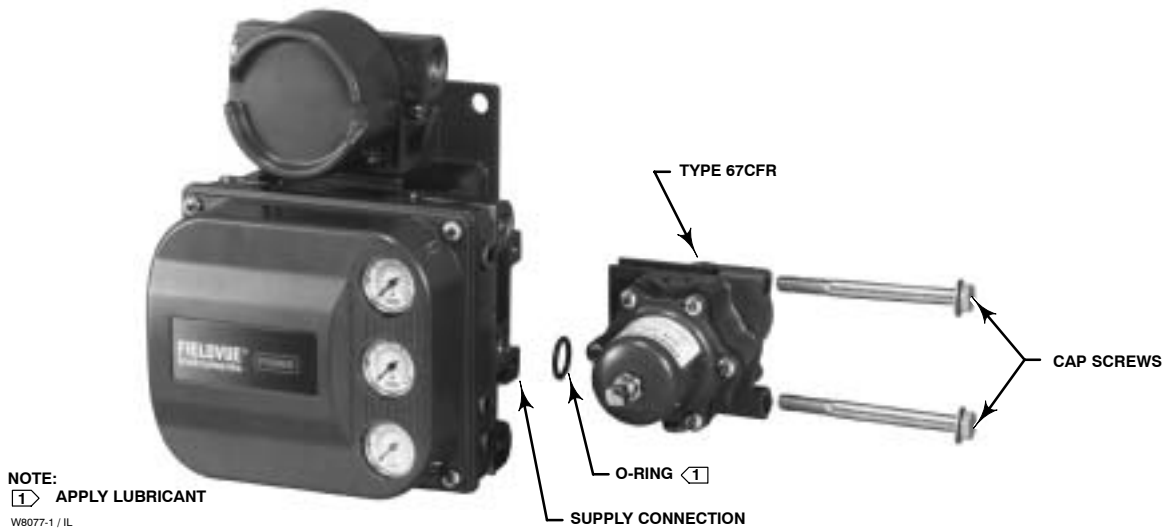

Figure 2-9. Mounting the Type 67CFR Regulator on a DVC6000 Series Digital Valve Controller

Mounting for Remote Mount DVC6000 Instruments

Refer to the DVC6000 Series Digital Valve Controller instruction manual, Form 5647.

then attach this assembly to the actuator casing. Thread a 1/4-inch socket-head pipe plug into the unused outlet on the filter regulator. No O-ring is required.

Mounting the 67CFR Filter Regulator

A Type 67CFR filter regulator, when used with the DVC6000 Series digital valve controllers, can be mounted three ways.

Integral-Mounted Regulator

Refer to figure 2-9. Lubricate an O-ring and insert it in the recess around the SUPPLY connection on the digital valve controller. Attach the Type 67CFR filter regulator to the side of the digital valve controller. Thread a 1/4-inch socket-head pipe plug into the unused outlet on the filter regulator. This is the standard method of mounting the filter regulator.

Yoke-Mounted Regulator

Mount the filter regulator with 2 cap screws to the pre-drilled and tapped holes in the actuator yoke. Thread a 1/4-inch socket-head pipe plug into the unused outlet on the filter regulator. No O-ring is required.

Casing-Mounted Regulator

Use the separate Type 67CFR filter regulator casing mounting bracket provided with the filter regulator. Attach the mounting bracket to the Type 67CFR and

Pressure Connections



WARNING

Observe the Installation WARNING at the beginning of this section.

Pressure connections are shown in figure 2-10. All pressure connections on the digital valve controller are 1/4 NPT internal connections. Use 10 mm (3/8-inch) tubing for all pressure connections. If remote venting is required, refer to the vent subsection.



Note

Make pressure connections to the digital valve controller using tubing with at least 10 mm (0.375 inch) diameter.

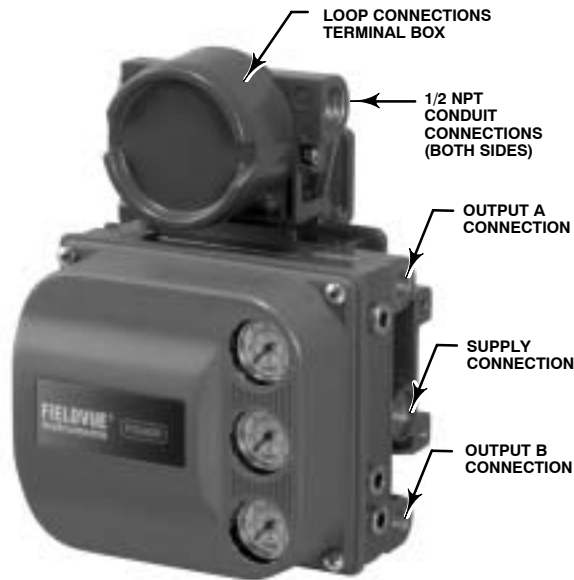

W7963-1 / IL

VALVE-MOUNTED INSTRUMENT

Figure 2-10. DVC6000 Series Digital Valve Controller Connections

Supply Connections

WARNING

To avoid personal injury and property damage resulting from bursting of parts, do not exceed maximum supply pressure.

WARNING

Severe personal injury or property damage may occur from an uncontrolled process if the instrument supply medium is not clean, dry, oil-free, and noncorrosive. While use and regular maintenance of a filter that removes particles larger than 40 microns in diameter will suffice in most applications, check with an Emerson Process Management field office and industry instrument air quality standards for use with corrosive air or if you are unsure about the amount of air filtration or filter maintenance.

Supply pressure must be clean, dry air that meets the requirements of ISA Standard 7.0.01. A maximum 40 micrometer particle size in the air system is acceptable. Further filtration down to 5 micrometer particle size is recommended. Lubricant content is not to exceed 1 ppm weight (w/w) or volume (v/v) basis. Condensation in the air supply should be minimized. Alternatively, natural gas may be used as the supply pressure medium. Gas must be clean, dry, oil-free, and noncorrosive. H₂S content should not exceed 20 ppm.

If you are using a Type 67CFR filter regulator, connect the supply line to the 1/4-inch NPT IN connection and attach tubing from the output connection on the filter regulator to the SUPPLY connection on the instrument. If you are using an integral mounted Type 67CFR filter regulator, connect the supply to the IN connection on the regulator.

Output Connection

A factory mounted digital valve controller has its output piped to the supply connection on the actuator. If mounting the digital valve controller in the field, connect the 1/4 NPT digital valve controller output connection to the pneumatic actuator input connection.

DVC6000 Series

2



Figure 2-11. DVC6010 Digital Valve Controller Mounted on Type 585C Piston Actuator

Single-Acting Actuators

When using a single-acting direct digital valve controller (relay type A or C) on a single-acting actuator, connect OUTPUT A to the actuator pneumatic input.

When using a single-acting reverse digital valve controller (relay type B) on a single-acting actuator, connect OUTPUT B to the actuator diaphragm casing.

Double-Acting Actuators

DVC6000 digital valve controllers on double-acting actuators always use relay type A. With no input current, OUTPUT A is at 0 pressure and OUTPUT B is at full supply pressure when the relay is properly adjusted.

To have the actuator stem extend from the cylinder with increasing input signal, connect OUTPUT A to the upper actuator cylinder connection. Connect OUTPUT B to the lower cylinder connection. Figure 2-11 shows the digital valve controller connected to a double-acting piston actuator.

To have the actuator stem retract into the cylinder with increasing input signal, connect OUTPUT A to the lower actuator cylinder connection. Connect OUTPUT B to the upper cylinder connection.

Vent

WARNING

Personal injury or property damage can occur from cover failure due to overpressure. Ensure that the housing vent opening is open and free of debris to prevent pressure buildup under the cover.

WARNING

This unit vents the supply medium into the surrounding atmosphere. When installing this unit in a non-hazardous (non-classified) location in a confined area, with natural gas as the supply medium, you must remotely vent this unit to a safe location. Failure to do so could result in personal injury or property damage from fire or explosion, and area re-classification.

When installing this unit in a hazardous (classified) location remote venting of the unit may be required, depending upon the area classification, and as specified by the requirements of local, regional, and federal codes, rules and regulations. Failure to do so when necessary could result in personal injury or property damage from fire or explosion, and area re-classification.

Vent line piping should comply with local and regional codes and should be as short as possible with adequate inside diameter and few bends to reduce case pressure buildup.

In addition to remote venting of the unit, ensure that all caps and covers are correctly installed. Failure to do so could result in personal injury or property damage from fire or explosion, and area re-classification.

The relay output constantly bleeds a small amount of supply medium into the area under the cover. The vent

openings at the back of the housing should be left open to prevent pressure buildup under the cover. If a remote vent is required, the vent lines must be as short as possible with a minimum number of bends and elbows.

Wiring and Electrical Connections

WARNING

Observe the Installation WARNING at the beginning of this section.

To avoid personal injury resulting from electrical shock, do not exceed maximum input voltage specified in table 4-1 of this quick start guide, or on the product nameplate. If the input voltage specified differs, do not exceed the lowest specified maximum input voltage.

Personal injury or property damage caused by fire or explosion may occur if this connection is attempted in a potentially explosive atmosphere or in an area that has been classified as hazardous. Confirm that area classification and atmosphere conditions permit the safe removal of the terminal box cover before proceeding.

WARNING

Select wiring and/or cable glands that are rated for the environment of use (such as hazardous area, ingress protection and temperature). Failure to use properly rated wiring and/or cable glands can result in personal injury or property damage from fire or explosion.

4 to 20 mA Loop Connections

The digital valve controller is normally powered by a control system output card. The use of shielded cable

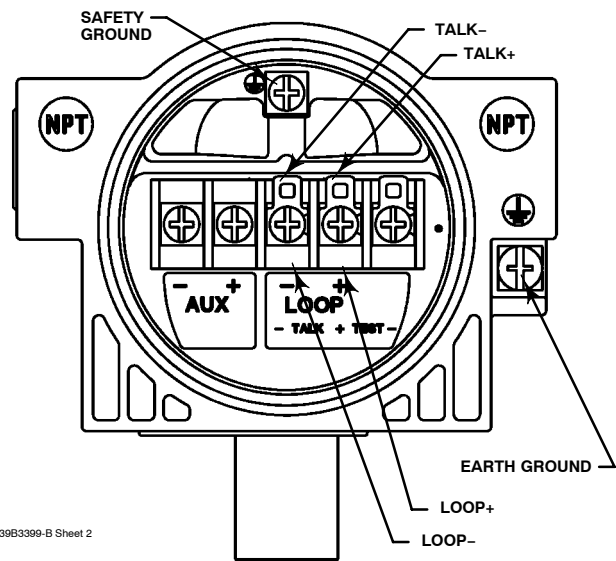

Figure 2-12. DVC6000 Series Digital Valve Controller Loop Connections Terminal Box

will ensure proper operation in electrically noisy environments.



Note

Connect the digital valve controller to a 4 to 20 mA current source for operation in the point-to-point wiring mode. In the point-to-point wiring mode, the digital valve controller will not operate when connected to a voltage source.

Wire the digital valve controller as follows, refer to figure 2-12:

1. Remove the loop connections terminal box cap (see figure 2-10).
2. Route the field wiring into the terminal box. When applicable, install conduit using local and national electrical codes which apply to the application.
3. Connect the control system output card positive wire "current output" to the LOOP + screw terminal in the terminal box. Connect the control system output card negative (or return) wire to the LOOP – screw terminal in the terminal box.
4. As shown in figure 2-12, two ground terminals are available for connecting a safety ground, earth ground, or drain wire. The safety ground is electrically identical to the earth ground. Make connections to these terminals following national and local codes and plant standards.

DVC6000 Series

5. Replace and hand tighten the terminal box cap. When the loop is ready for startup, apply power to the control system output card.

WARNING

Personal injury or property damage, caused by fire or explosion, can result from the discharge of static electricity. Connect a 14 AWG (2.08 mm²) ground strap between the digital valve controller and earth ground when flammable or hazardous gases are present. Refer to national and local codes and standards for grounding requirements.

To avoid static discharge from the plastic cover, do not rub or clean the cover with solvents. Clean with a mild detergent and water only.

2

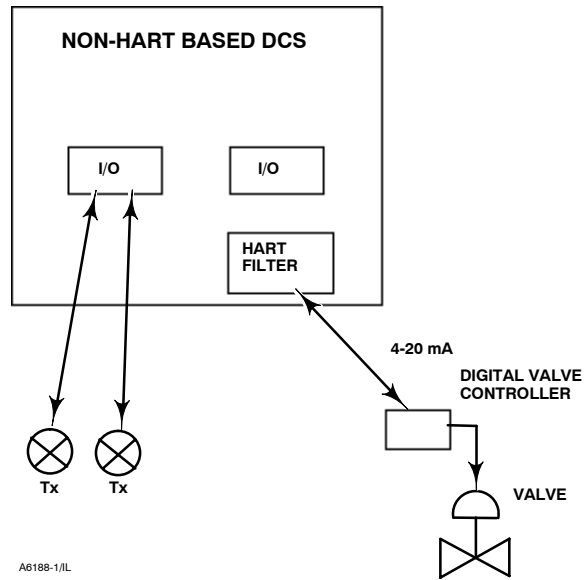

Figure 2-13. HART[®] Filter Application

HART[®] Filter

Depending on the control system you are using, a HART filter may be needed to allow HART communication. The HART filter is an active device that is inserted in field wiring from the HART loop. The filter is normally installed near the field wiring terminals of the control system I/O (see figure 2-13). Its purpose

is to effectively isolate the control system output from modulated HART communication signals and raise the impedance of the control system to allow HART communication. For more information on the description and use of the HART filter, refer to the appropriate separate HART filter instruction manual.

To determine if your system requires a filter contact your Emerson Process Management sales office.

✓ Installation Check List

Mounting

- Is the instrument correctly mounted on the actuator? If not, refer to appropriate mounting procedure and see installation instructions provided with the mounting kit.
- Is the feedback linkage properly connected? If not, see installation instructions provided with the mounting kit.

2

Pneumatic Connections and Air Supply

- Is the regulator correctly mounted? If not, perform one of the regulator mounting procedures on page 2-10.
- Is the air supply connected and at proper pressure? If not, connect supply as described on page 2-11. Also see specifications on page 4-1.
- Is the instrument output connected to the actuator? If not, connect instrument output as described on page 2-11.

Wiring and Electrical Connections

- If necessary, is the conduit properly installed? If not, refer to local and national electrical codes.
- Is the loop wiring properly connected to the LOOP + and – terminals in the terminal box? If not, connect loop wiring as described on page 2-13.
- If necessary, is the HART filter installed on your system? To determine if a HART filter is necessary, contact your Emerson Process Management sales office. For HART filter installation information, refer to the appropriate HART instruction manual.

You are ready to perform Basic Setup and Calibration in the next section.

3

From the DVC6000 Online menu, select Configure / Setup

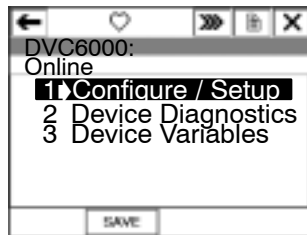

From the Configure / Setup menu, select Basic Setup.

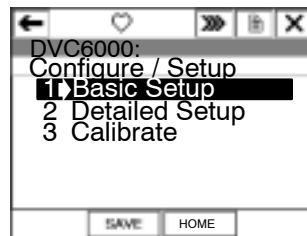

From the Basic Setup menu, select Setup Wizard and follow the on-line instructions



INSTRUMENT LEVEL HC, AD, and PD

Figure 3-2. Accessing the Setup Wizard on the 375 Field Communicator

Connect a 4–20 mA current source to the instrument. Connect the Field Communicator to the instrument and turn it on. For information on connecting the Field Communicator, see Connecting the 375 Field Communicator to the Digital Valve Controller .

Typical Actuators

The Setup Wizard determines the required setup information based upon the actuator manufacturer and model specified. Turn on the Field Communicator and start the Setup Wizard by proceeding through the menu sequence shown in figure 3-2 or enter the fast-key sequence 1-1-1 on the keypad. Follow the prompts on the Field Communicator display to setup the instrument. If the actuator on which the instrument is mounted is not listed by the Setup Wizard, specify OTHER as the actuator manufacturer or actuator type and refer to Non-Typical Actuators.

WARNING

During calibration the valve will move full stroke. To avoid personal injury and property damage caused by the release of pressure or process fluid, provide some temporary means of control for the process.

After completing the setup information, travel is automatically calibrated. Follow the prompts on the Field Communicator display. The calibration procedure uses the valve and actuator stops as the 0% and 100% calibration points. For additional information, refer to Auto Calibrate Travel in this section.

When travel calibration is complete, you are asked if you wish to adjust the relay (double-acting only). Select yes to adjust the relay. For additional information, refer to Relay Adjustment in this section.

Non-Typical Actuators

If the actuator on which the instrument is mounted is not listed by the Setup Wizard, specify OTHER as the actuator manufacturer or actuator type. You are then prompted for setup parameters such as:

- **Actuator Style** (spring & diaphragm, piston double-acting without spring, piston single-acting with spring, piston double-acting with spring)

- **Valve Style** (rotary or sliding-stem)

- **On Loss of Instrument Signal, Valve (opens or closes)** This identifies whether the valve is fully open or fully closed when the input is 0%. If you are unsure how to set this parameter, disconnect the current source to the instrument. (With double-acting and single-acting direct digital valve controllers, disconnecting the current source is the same as setting the output A pressure to zero. For single-acting reverse digital valve controllers, disconnecting the current source is the same as setting the output B pressure to supply.)

- **Feedback Connection** (Rotary - All, SStem - Standard, SStem - Roller). For rotary valves, enter Rotary - All. For sliding-stem valves, if the feedback linkage consists of a connector arm, adjustment arm, and feedback arm (similar to figure 3-5), enter SStem - Standard. If the feedback linkage consists of a roller that follows a cam (similar to figure 3-3), enter SStem - Roller.

- **Travel Sensor Motion** The Setup Wizard asks if it can move the valve to determine travel sensor motion. If you answer Yes, the instrument will stroke

Basic Setup and Calibration

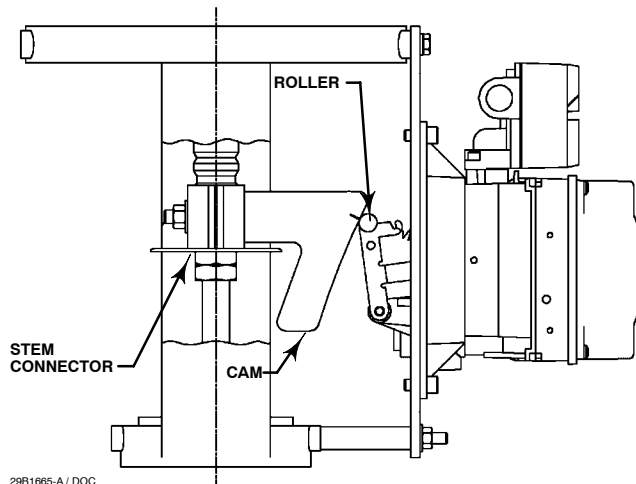

Figure 3-3. Feedback Connection for Typical Long-Stroke Sliding-Stem Actuator (4 to 24-inches travel)

the valve the full travel span to determine travel sensor motion. If you answer No, then you must specify the rotation for increasing air pressure: clockwise or counterclockwise. Determine rotation by viewing the end of the travel sensor shaft.

Table 3-1. DVC6000 Series Factory Default Settings

Setup Parameter	Default Setting
Analog Input Units	mA
Analog In Range High	20.0 mA
Analog In Range Low	4.0 mA
Control Mode	Analog
Restart Control Mode	Resume Last
Self-Test Shutdown	All Failures Disabled
Set Point Filter Time	Filter Off
Input Characteristic	Linear
Travel Limit High	125%
Travel Limit Low	-25%
Travel Cutoff High	99.5%
Travel Cutoff Low	0.5%
Minimum Opening Time	0 secs
Minimum Closing Time	0 secs
Polling Address	0
Aux Terminal Mode	Aux Input Alert
Command 3 Pressure	
Double-acting actuators	differential output pressure
Single-acting actuators	actuator pressure

WARNING

If you answer YES to the prompt for permission to move the valve, the instrument will move the valve through a significant portion of its travel range. To avoid personal injury and property damage caused by the release of pressure or process fluid, provide some temporary means of control for the process.

For instruments with Relay Type A or C. If increasing air pressure at output A causes the shaft to turn clockwise, enter Clockwise. If it causes the shaft to turn counterclockwise, enter Cntrclockwise.

For instruments with Relay Type B. If decreasing air pressure at output B causes the shaft to turn clockwise, enter Clockwise. If it causes the shaft to turn counterclockwise, enter Cntrclockwise.



Note

Relay adjustment may be required before the Setup Wizard can determine travel sensor motion. Follow the prompts on the Field Communicator display if relay adjustment is necessary.

- **Volume Booster** The Setup Wizard asks if a volume booster or quick release is present.

DVC6000 Series

• **Tuning Set** There are twelve tuning sets from which to choose. Each tuning set provides preselected values for the digital valve controller gain and rate settings. Typically, tuning set B provides the slowest response and M provides the fastest response. For smaller actuators, use tuning set C or D. For larger actuators, use tuning set F or G.

WARNING

3

Changes to the tuning set may cause the valve/actuator assembly to stroke. To avoid personal injury and property damage caused by moving parts, keep hands, tools, and other objects away from the valve/actuator assembly.

In addition, you can select User Adjusted or Expert, which allows you to modify tuning of the digital valve controller. With User Adjusted you can specify the proportional gain. An algorithm in the Field Communicator calculates the other gains. With Expert you can specify not only the proportional gain but the velocity and minor loop feedback gain as well.



Note

Use Expert tuning only if standard tuning has not achieved the desired results.

Stabilize/Optimize or Performance Tuner may be used to achieve the desired results more rapidly than Expert tuning.

The tuning sets suggested by the Setup Wizard are only recommended starting points. After you finish setting up and calibrating the instrument, run the Performance Tuner or use Stabilize/Optimize Tuning to obtain optimum tuning.

Factory Defaults

During basic setup, the Setup Wizard will ask you if you want to use factory defaults. If you select YES, the Setup Wizard sets the setup parameters to the

values listed in table 3-1. (Yes is recommended for initial setup). If you select NO, the setup parameters listed in the table remain at their previous settings.

Relay Adjustment

The double-acting relay can be adjusted as part of the Setup Wizard. The following is a brief description of relay adjustment. For additional information, see the Calibration section in the DVC6000 instruction manual.



Note

Relay B and C are not user-adjustable.

Double-Acting Relay (Relay A)

The double-acting relay is designated by Relay A. For double-acting actuators, the valve must be near mid-travel to properly adjust the relay. The Field Communicator will automatically position the valve when *Relay Adjust* is selected.

Rotate the adjustment disc, shown in figure 3-4, until the value displayed on the Field Communicator is between 50 and 70% of supply pressure. This adjustment is very sensitive. Be sure to allow the pressure reading to stabilize before making another adjustment (stabilization may take up to 30 seconds or more for larger actuators).

If the low bleed relay option has been ordered stabilization may take approximately two minutes longer than the standard relay.

Relay A may also be adjusted for use in single-acting-direct applications. Rotate the adjustment disc as shown in figure 3-4 for single-acting direct operation.

Single-Acting Direct Relay (Relay C)

The single-acting direct relay is designated Relay C, and requires no adjustment.

Single-Acting Reverse Relay (Relay B)

The single-acting reverse relay is designated Relay B. Relay B is calibrated at the factory and requires no further adjustment.

Basic Setup and Calibration

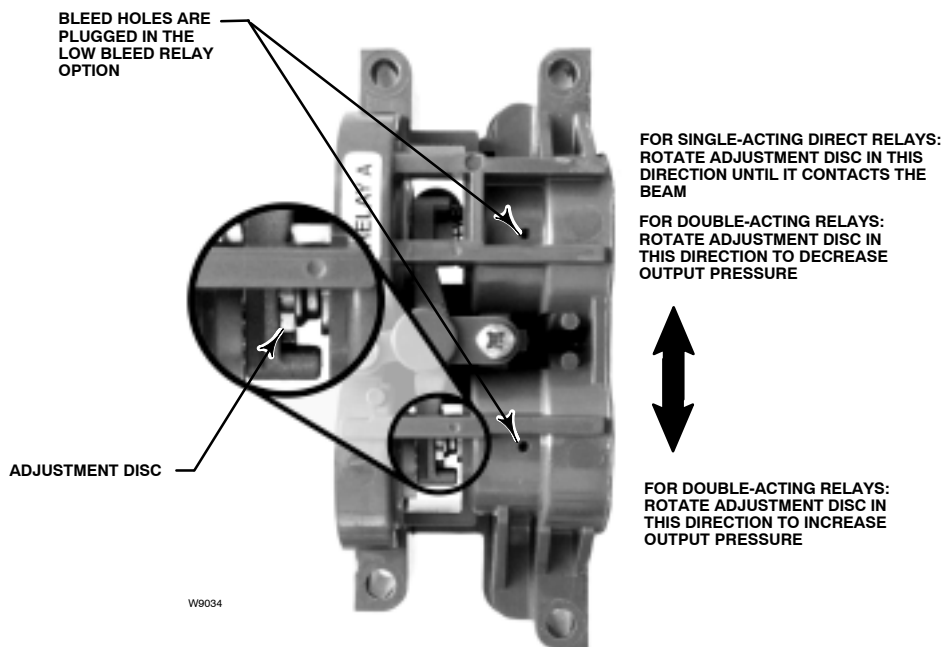

Figure 3-4. Relay A Adjustment (Shroud Removed for Clarity)

Auto Calibrate Travel

WARNING

During calibration the valve will move full stroke. To avoid personal injury and property damage caused by the release of pressure or process fluid, provide some temporary means of control for the process.

The instrument is calibrated during the Setup Wizard. Follow the prompts on the Field Communicator display to automatically calibrate instrument travel. The calibration procedure uses the valve and actuator stops as the 0% and 100% calibration points.

For additional calibration information, refer to the DVC6000 instruction manual.

1. If the Feedback Connection is Sliding-Stem Standard, the Field Communicator prompts you to select the method of crossover adjustment: manual, last value, or default. Manual adjustment is recommended for initial travel calibration.
2. When prompted by the Field Communicator, make the crossover adjustment by adjusting the current source until the feedback arm is 90° to the actuator stem, as shown in figure 3-5.
3. The remainder of the auto-calibration procedure is automatic. After completing auto travel calibration, the

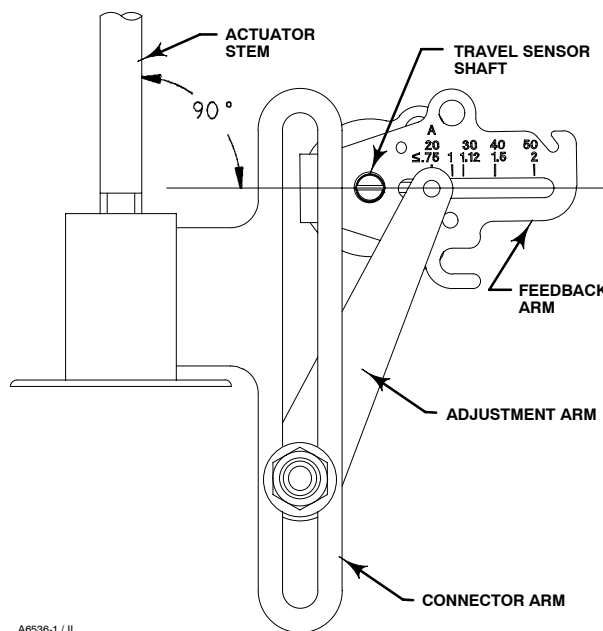

Figure 3-5. Crossover Point

Field Communicator prompts you to place the instrument In Service and verify that the travel properly tracks the current source.

If the unit does not calibrate, refer to table 3-2 for error messages and possible remedies.

DVC6000 Series

Table 3-2. Auto Calibrate Travel Error Messages

Error Message	Possible Problem and Remedy
Input current must exceed 3.8 mA for calibration.	The analog input signal to the instrument must be greater than 3.8 mA. Adjust the current output from the control system or the current source to provide at least 4.0 mA.
Place Out Of Service and ensure Calibrate Protection is disabled before calib.	The Instrument Mode must be <i>Out of Service</i> and the Protection must be <i>None</i> before the instrument can be calibrated.
Calibration Aborted. An end point was not reached.	The problem may be one or the other of the following: 1. The tuning set selected is too low and the valve does not reach an end point in the allotted time. Press the Hot Key, select <i>Stabilize/Optimize</i> then <i>Increase Response</i> (selects next higher tuning set). 2. The tuning set selected is too high, valve operation is unstable and does not stay at an end point for the allotted time. Press the Hot Key, select <i>Stabilize/Optimize</i> then <i>Decrease Response</i> (selects next lower tuning set).
Invalid travel value. Check mounting and feedback arm adjustments, and inst supply press. Then, repeat Auto Calib.	Verify proper mounting by referring to the appropriate mounting instructions. Verify instrument supply pressure by referring to the specifications in the appropriate actuator instruction manual. Making the crossover adjustment with the valve positioned at either end of its travel will also cause this message to appear.
Aborting due to response code or device status.	The instrument may have been taken out of service by a primary master. Put the instrument into service with the primary master or cycle the power off and on.

3

If after completing setup and calibration the valve cycles or overshoots (unstable), or is unresponsive (sluggish), you can improve operation by selecting either *Performance Tuner* or *Stabilize/Optimize* from the *Basic Setup* menu.

Stabilizing or Optimizing or (1-1-2) Valve Response



Note

Stabilize/Optimize is only available through the Basic Setup menu for instrument level HC.

Using the Performance Tuner (1-1-2)



Note

The Performance Tuner is not available for instrument level AC or HC.

The Performance Tuner is used to optimize digital valve controller tuning. It can be used on most sliding-stem and rotary designs, including Fisher and other manufacturers' products. Moreover, because the Performance Tuner can detect internal instabilities before they become apparent in the travel response, it can generally optimize tuning more effectively than manual tuning. Typically, the Performance Tuner

takes 3 to 5 minutes to tune an instrument, although tuning instruments mounted on larger actuators may take longer.

Access the Performance Tuner by selecting *Performance Tuner* from the *Basic Setup* menu. Follow the prompts on the Field Communicator display to optimize digital valve controller tuning.

If after completing setup and calibration the valve seems slightly unstable or unresponsive, you can improve operation by pressing the Hot Key and selecting *Stabilize/Optimize*, or select *Stabilize/Optimize* from the *Basic Setup* menu.

Stabilize/Optimize permits you to adjust valve response by changing the digital valve controller tuning.

If the valve is unstable, select *Decrease Response* to stabilize valve operation. This selects the next lower tuning set (e.g., F to E). If the valve response is sluggish, select *Increase Response* to make the valve more responsive. This selects the next higher tuning set (e.g., F to G).

If after selecting *Decrease Response* or *Increase Response* the valve travel overshoot is excessive you can adjust the damping by selecting *Decrease Damping* or *Increase Damping*. By selecting *Decrease Damping* or *Increase Damping* the tuning set will become Expert, and allow you to select a damping value that is not represented in a predefined tuning set. Select *Decrease Damping* to select a damping value that allows more overshoot. Select *Increase Damping* to select a damping value that will decrease the overshoot.

✓ Basic Setup and Calibration Check List

- Is basic setup complete? If not, perform Basic Setup procedure on page 3-1.

- Does the final control element correctly respond to a setpoint change and is it stable? If not, perform Stabilizing or Optimizing Valve Response on page 3-6.

Final control element is ready to be placed on line.

Specifications and Related Documents

Table 4-1. Specifications

<p>Available Configurations</p> <p>Valve-Mounted Instrument <i>DVC6010:</i> Sliding stem applications <i>DVC6020:</i> Rotary and long-stroke sliding-stem applications <i>DVC6030:</i> Quarter-turn rotary applications</p> <p>Remote-Mounted Instrument⁽¹⁾ <i>DVC6005:</i> Base unit for 2-inch pipestand or wall mounting <i>DVC6015:</i> Feedback unit for sliding-stem applications <i>DVC6025:</i> Feedback unit for rotary or long-stroke sliding-stem applications <i>DVC6035:</i> Feedback unit for quarter-turn rotary applications</p> <p>DVC6000 Series digital valve controllers can be mounted on Fisher and other manufacturers rotary and sliding-stem actuators.</p> <p>Input Signal</p> <p>Point-to-Point: <i>Analog Input Signal:</i> 4 to 20 mA DC, nominal Minimum Voltage Available at instrument terminals must be 10.5 volts DC for analog control, 11 volts DC for HART communication (see instrument instruction manual for details) <i>Minimum Control Current:</i> 4.0 mA <i>Minimum Current w/o Microprocessor Restart:</i> 3.5 mA <i>Maximum Voltage:</i> 30 volts DC <i>Overcurrent Protection:</i> Input circuitry limits current to prevent internal damage. <i>Reverse Polarity Protection:</i> No damage occurs from reversal of loop current.</p> <p>Multi-drop: <i>Instrument Power:</i> 11 to 30 volts DC at approximately 8 mA <i>Reverse Polarity Protection:</i> No damage occurs from reversal of loop current.</p> <p>Output Signal</p> <p>Pneumatic signal as required by the actuator, up to full supply pressure. Minimum Span: 0.4 bar (6 psig) Maximum Span: 9.5 bar (140 psig) Action: Double, Single direct, and Single reverse</p> <p>Supply Pressure⁽²⁾</p> <p>Recommended: 0.3 bar (5 psi) higher than maximum actuator requirements, up to maximum supply pressure Maximum: 10.0 bar (145 psig) or maximum pressure rating of the actuator, whichever is lower</p>	<p>Medium: Air or Natural Gas⁽³⁾</p> <p><i>Air Quality:</i> Supply pressure must be clean, dry air that meets the requirements of ISA Standard 7.0.01. A maximum 40 micrometer particle size in the air system is acceptable. Further filtration down to 5 micrometer particle size is recommended. Lubricant content is not to exceed 1 ppm weight (w/w) or volume (v/v) basis. Condensation in the air supply should be minimized</p> <p><i>Natural Gas:</i> Natural gas must be clean, dry, oil-free, and noncorrosive. H₂S content should not exceed 20 ppm.</p> <p>Steady-State Air Consumption⁽⁴⁾</p> <p>Standard Relay: <i>At 1.4 bar (20 psig) supply pressure:</i> Less than 0.38 normal m³/hr (14 scfh) <i>At 5.5 bar (80 psig) supply pressure:</i> Less than 1.3 normal m³/hr (49 scfh) Low Bleed Relay⁽⁵⁾: <i>At 1.4 bar (20 psig) supply pressure:</i> Average value 0.056 normal m³/hr (2.1 scfh) <i>At 5.5 bar (80 psig) supply pressure:</i> Average value 0.184 normal m³/hr (6.9 scfh)</p> <p>Maximum Output Capacity⁽⁴⁾</p> <p><i>At 1.4 bar (20 psig) supply pressure:</i> 10.0 normal m³/hr (375 scfh) <i>At 5.5 bar (80 psig) supply pressure:</i> 29.5 normal m³/hr (1100 scfh)</p> <p>Failure Modes</p> <p>Refer to figure 4-1</p> <p>Independent Linearity⁽⁶⁾</p> <p>±0.50% of output span</p> <p>Electromagnetic Interference (EMI)</p> <p>Tested per IEC 61326-1 (Edition 1.1). Meets emission levels for Class A equipment (industrial locations) and Class B equipment (domestic locations). Meets immunity requirements for industrial locations (Table A.1 in the IEC specification document). Immunity performance is shown in table 4-2.</p> <p><i>Lightning and Surge Protection</i>—The degree of immunity to lightning is specified as Surge immunity in table 4-2. For additional surge protection commercially available transient protection devices can be used.</p>
---	---

–continued–

DVC6000 Series

Table 4-1. Specifications (continued)

Vibration Resistance

Tested per ISA-S75.13 Section 5.3.5. A resonant frequency search is performed on all three axes. The instrument is subjected to the ISA specified 1/2 hour endurance test at each major resonance, plus an additional two million cycles.

Input Impedance

The input impedance of the DVC6000 active electronic circuit is not purely resistive. For comparison to resistive load specifications, an equivalent impedance of 550 ohms may be used. This value corresponds to 11V @ 20 mA.

Operating Ambient Temperature Limits⁽²⁾

- 40 to 80°C (-40 to 176°F) for most approved valve-mounted instruments
- 60 to 125°C (-76 to 257°F) for remote-mounted feedback unit.
- 52 to 80°C (-62 to 176°F) for valve-mounted instruments utilizing the Extreme Temperature option (fluorosilicone elastomers)

Humidity Limits

0 to 100% condensing relative humidity with minimal zero or span shifts

Electrical Classification

Hazardous Area:



Explosion proof, Division 2,
Dust-Ignition proof, Intrinsic Safety



Explosion proof, Non-incendive,
Dust-Ignition proof, Intrinsic Safety

ATEX Flameproof, Type n, Intrinsic Safety

IECEX Flameproof, Type n, Intrinsic Safety



Flameproof, Intrinsic Safety



Flameproof, Intrinsic Safety

Refer to Special Instructions for Safe Use and Installation in Hazardous Locations in Section 2, tables 4-3, 4-4, 4-5, 4-6, and 4-7 and figures 5-1,

5-2, 5-3, 5-4, 5-5, 5-6, 5-7, 5-8, and 5-9 for specific approval information.

Pollution Degree 2, Overvoltage Category III per ANSI/ISA-82.02.01 (IEC 61010-1 Mod).

Electrical Housing: Meets NEMA 4X, CSA Type 4X, IEC 60529 IP66

Other Classifications/Certifications

TIIS Japan

KISCO Korea Industrial Safety Corp.



Russian GOST-R

Russian – Federal Service of
FSETAN Technological, Ecological and Nuclear
Inspectorate

Contact your Emerson Process Management sales office for classification/certification specific information

IEC 61010 Compliance Requirements (Valve-Mounted Instruments only)

Power Source: The loop current must be derived from a Separated Extra-Low Voltage (SELV) power source.

Environmental Conditions: Installation Category I

Connections

Supply Pressure: 1/4 NPT internal and integral pad for mounting 67CFR regulator

Output Pressure: 1/4 NPT internal

Tubing: 3/8-inch metal, recommended

Vent (pipe-away): 3/8 NPT internal

Electrical: 1/2 NPT internal conduit connection
optional—M20 internal conduit connection, spring clamp terminal connection⁽⁷⁾

Stem Travel

DVC6010, DVC6015: 0 to 102 mm (4-inches)
maximum travel span

0 to 9.5 mm (0.375 inches) minimum travel span

DVC6020, DVC6025: 0 to 606 mm (23.875 inches)
maximum travel span

Shaft Rotation (DVC6020, DVC6025, DVC6030, and DVC6035)

0 to 50 degrees minimum

0 to 90 degrees maximum

–continued–

Specifications and Related Documents

Table 4-1. Specifications (continued)

<p>Mounting⁽⁸⁾</p> <p>Designed for direct actuator mounting or remote pipestand or wall mounting. Mounting the instrument vertically, with the vent at the bottom of the assembly, or horizontally, with the vent pointing down, is recommended to allow drainage of moisture that may be introduced via the instrument air supply.</p> <p>Weight</p> <p>Valve-Mounted Instruments Aluminum: 3.5 kg (7.7 lbs) Stainless Steel: 7.7 kg (17 lbs)</p> <p>Remote-Mounted Instruments <i>DVC6005 Base Unit:</i> 4.1 kg (9 lbs) <i>DVC6015 Feedback Unit:</i> 1.3 kg (2.9 lbs) <i>DVC6025 Feedback Unit:</i> 1.4 kg (3.1 lbs) <i>DVC6035 Feedback Unit:</i> 0.9 kg (2.0 lbs)</p>	<p>Options</p> <ul style="list-style-type: none"> ■ Supply and output pressure gauges or ■ Tire valves, ■ Integral mounted filter regulator, ■ Stainless steel housing, module base and terminal box (valve-mounted instruments only) ■ Low bleed relay ■ In-line 10 micron air filter ■ Safety Instrumented System (SIS) Solutions ■ Safety Related Nuclear Applications <p>Declaration of SEP</p> <p>Fisher Controls International LLC declares this product to be in compliance with Article 3 paragraph 3 of the Pressure Equipment Directive (PED) 97 / 23 / EC. It was designed and manufactured in accordance with Sound Engineering Practice (SEP) and cannot bear the CE marking related to PED compliance.</p> <p>However, the product <i>may</i> bear the CE marking to indicate compliance with <i>other</i> applicable European Community Directives.</p>
---	--

4

NOTE: Specialized instrument terms are defined in ISA Standard 51.1 – Process Instrument Terminology.

1. 3-conductor shielded cable, 22 AWG minimum wire size, is required for connection between base unit and feedback unit. Pneumatic tubing between base unit output connection and actuator has been tested to 15 meters (50 feet) maximum without performance degradation.
2. The pressure/temperature limits in this quick start guide and any applicable code or standard should not be exceeded.
3. Suitable for use with natural gas as the supply medium. CSA FM, ATEX, and IECEx gas certifications pending. Contact you Emerson Process Management sales office for information on pending approvals.
4. Values at 1.4 bar (20 psig) based on a single-acting direct relay; values at 5.5 bar (80 psig) based on double-acting relay.
5. The low bleed relay is offered as standard relay for DVC6000 SIS tier, used for On/Off applications.
6. Typical value. Not applicable for travels less than 19 mm (0.75 inch) or for shaft rotation less than 60 degrees. Also not applicable for DVC6020 digital valve controllers in long-stroke applications.
7. ATEX/IEC approvals only.
8. Do not use the DVC6010S or DVC6020S in high vibration service where the mounting bracket uses standoffs (spacers) to mount to the actuator. Due to NAMUR mounting limitations, do not use the DVC6030S in high vibration service.

Table 4-2. Immunity Performance

PORT	PHENOMENON	BASIC STANDARD	TEST LEVEL	PERFORMANCE CRITERIA ⁽¹⁾	
				Point-to-Point Mode	Multi-drop Mode
Enclosure	Electrostatic discharge (ESD)	IEC 61000-4-2	4 kV contact 8 kV air	A ⁽²⁾	A
	Radiated EM field	IEC 61000-4-3	80 to 1000 MHz @ 10V/m with 1 kHz AM at 80%	A	A
	Rated power frequency magnetic field	IEC 61000-4-8	60 A/m at 50 Hz	A	A
I/O signal/control	Burst	IEC 61000-4-4	1 kV	A ⁽²⁾	A
	Surge	IEC 61000-4-5	1 kV (line to ground only, each)	A ⁽²⁾	A
	Conducted RF	IEC 61000-4-6	150 kHz to 80 MHz at 3 Vrms	A	A

1. A = No degradation during testing. B = Temporary degradation during testing, but is self-recovering.
 2. Excluding auxiliary switch function, which meets Performance Criteria B.

DVC6000 Series

Table 4-3. Hazardous Area Classifications—North America (CSA and FM)

CERTIFICATION BODY	CERTIFICATION OBTAINED	ENTITY RATING	TEMPERATURE CODE	ENCLOSURE RATING
CSA	(Intrinsic Safety) Class/Division Class I,II,III Division 1 GP A,B,C,D,E,F,G per drawing 29B3428	$V_{max} = 30$ VDC $I_{max} = 226$ mA $C_i = 5$ nF $L_i = 0.55$ mH	T5($T_{amb} \leq 80^\circ\text{C}$)	4X
	(Explosion Proof) Class/Division Class I Division 1 GP B,C,D	---	T6($T_{amb} \leq 80^\circ\text{C}$)	4X
	Class I Division 2 GP A,B,C,D Class II Division 1 GP E,F,G Class III Division 1	---	T6($T_{amb} \leq 80^\circ\text{C}$)	4X
FM	(Intrinsic Safety) Class/Division Class I,II,III Division 1 GP A,B,C,D,E,F,G per drawing 29B3427	$V_{max} = 30$ VDC $I_{max} = 226$ mA $P_i = 1.4$ W $C_i = 5$ nF $L_i = 0.55$ mH	T5($T_{amb} \leq 80^\circ\text{C}$)	4X
	(Explosion Proof) Class/Division Class I Division 1 GP B,C,D	---	T6($T_{amb} \leq 80^\circ\text{C}$)	4X
	Class I Division 2 GP A,B,C,D Class II,III Division 1 GP E,F,G Class II,III Division 2 GP F,G	---	T6($T_{amb} \leq 80^\circ\text{C}$)	4X

Table 4-4. Hazardous Area Classifications—ATEX

CERTIFICATE	CERTIFICATION OBTAINED	ENTITY RATING	TEMPERATURE CODE	ENCLOSURE RATING
ATEX	Ⓔ II 1 G & D Gas EEx ia IIC T5/T6 —Intrinsic Safety Dust T85°C ($T_{amb} \leq 80^\circ\text{C}$)	$U_i = 30$ VDC $I_i = 226$ mA $P_i = 1.4$ W $C_i = 5$ nF $L_i = 0.55$ mH	T5($T_{amb} \leq 80^\circ\text{C}$) T6 ($T_{amb} \leq 75^\circ\text{C}$)	IP66
	Ⓔ II 2 G & D Gas EEx d IIB+H2 T5/T6 —Flameproof Dust T90°C ($T_{amb} \leq 85^\circ\text{C}$)	---	T5($T_{amb} \leq 85^\circ\text{C}$) T6 ($T_{amb} \leq 75^\circ\text{C}$)	IP66
	Ⓔ II 3 G & D Gas EEx nCL IIC T5/T6 —Type n Dust T85°C ($T_{amb} \leq 80^\circ\text{C}$)	---	T5($T_{amb} \leq 80^\circ\text{C}$) T6 ($T_{amb} \leq 75^\circ\text{C}$)	IP66

Table 4-5. Hazardous Area Classifications—IECEX

CERTIFICATE	CERTIFICATION OBTAINED	ENTITY RATING	TEMPERATURE CODE	ENCLOSURE RATING
IECEX	Gas Ex ia IIC T5/T6 —Intrinsic Safety	$U_i = 30$ VDC $I_i = 226$ mA $P_i = 1.4$ W $C_i = 5$ nF $L_i = 0.55$ mH	T5($T_{amb} \leq 80^\circ\text{C}$) T6 ($T_{amb} \leq 75^\circ\text{C}$)	IP66
	Gas Ex d IIB+H2 T5/T6 —Flameproof	---	T5($T_{amb} \leq 80^\circ\text{C}$) T6 ($T_{amb} \leq 75^\circ\text{C}$)	IP66
	Gas0 Ex nC IIC T5/T6 —Type n	---	T5($T_{amb} \leq 80^\circ\text{C}$) T6 ($T_{amb} \leq 75^\circ\text{C}$)	IP66

Specifications and Related Documents

Table 4-6. Hazardous Area Classifications—NEPSI

CERTIFICATE	CERTIFICATION OBTAINED	ENTITY RATING	TEMPERATURE CODE	ENCLOSURE RATING
NEPSI	Gas Ex ia IIC T5/T6 —Intrinsic Safety Dust DIP A21 T5	$U_i = 30\text{ V}$ $I_i = 226\text{ mA}$ $C_i = 5\text{ nF}$ $L_i = 0.55\text{ mH}$ $P_i = 1.4\text{ W}$	T5($T_{\text{amb}} \leq 80^\circ\text{C}$) T6 ($T_{\text{amb}} \leq 75^\circ\text{C}$)	IP66
	Gas Ex d IIC T5/T6 ⁽¹⁾ —Flameproof Dust DIP A21 T5	---	T5($T_{\text{amb}} \leq 80^\circ\text{C}$) T6 ($T_{\text{amb}} \leq 75^\circ\text{C}$)	IP66

Table 4-7. Hazardous Area Classifications—INMETRO

CERTIFICATE	CERTIFICATION OBTAINED	ENTITY RATING	TEMPERATURE CODE	ENCLOSURE RATING
INMETRO	BR-Ex ia IIC T5	$U_i = 30\text{ V}$ $I_i = 180\text{ mA}$ $C_i = 5\text{ nF}$ $L_i = 0.55\text{ mH}$ $P_i = 1.4\text{ W}$	T5($T_{\text{amb}} \leq 80^\circ\text{C}$)	
	BR-Ex d IIB+H2 T6	---	T6 ($T_{\text{amb}} \leq 75^\circ\text{C}$)	

4

DVC6000 Series



RELAY TYPE	LOSS OF POWER	LOSS OF PNEUMATIC SUPPLY
Single Acting Direct (Relay C)	Instrument goes to zero air output at port A.	Failure direction per actuator fail mode.
Double Acting (Relay A)	Instrument goes to full supply air output at port B. A goes to zero air output.	Failure direction cannot be determined.
Single Acting Reverse (Relay B)	Instrument goes to full supply air output at port B.	Failure direction per actuator fail mode.

Figure 4-1. DVC6000 Digital Valve Controller Failure Modes

4

Related Documents

This section lists other documents containing information related to DVC6000 Series digital valve controllers. These documents include:

- DVC6000 Series FIELDVUE® Digital Valve Controller (Bulletin 62.1:DVC6000)
- DVC6000 Series FIELDVUE® Digital Valve Controllers Instruction Manual, Form 5647
- Supplement to HART® Based FIELDVUE® Digital Valve Controller Instruction Manuals—FIELDVUE® Digital Valve Controller Split Ranging – Form 5808
- Supplement to HART® Based FIELDVUE® Instrument Instruction Manuals—Using FIELDVUE® Instruments with the Smart HART® Loop Interface and Monitor (HIM) – Form 5809
- Supplement to HART® Based FIELDVUE® Instrument Instruction Manuals— Audio Monitor for HART® Communications – Form 5811
- Supplement to HART® Based FIELDVUE® Instrument Instruction Manuals— HART® Field Communication Protocol – Form 5812
- Supplement to HART® Based FIELDVUE® Instrument Instruction Manuals— Using the HART® Tri-Loop™ HART® -to-Analog Signal Converter with FIELDVUE® Digital Valve Controllers – Form 5813
- Supplement to DVC5000 and DVC6000 FIELDVUE® Digital Valve Controller Instruction Manuals— Hot Swap Procedure – Form 5810
- Supplement to DVC6000 FIELDVUE® Digital Valve Controllers Instruction Manual— Lock-in-Last Strategy – Form 5805
- Supplement to DVC6000 Series FIELDVUE® Digital Valve Controllers Instruction Manual— Model 275 HART® Communicator Menu Trees for Firmware 7 Digital Valve Controllers – Form 5819
- FIELDVUE® HF300 Series HART® Filters Instruction Manual - Form 5715
- Type 2530H1 HART® Interchange Multiplexer Instruction Manual - Form 5407
- AMS™ ValveLink® Software Help or Documentation

All documents are available from your Emerson Process Management sales office. Also visit our website at www.FIELDVUE.com.

Educational Services

For information on available courses for DVC6000 Series digital valve controllers, as well as a variety of other products, contact:

Emerson Process Management
 Educational Services, Registration
 P.O. Box 190; 301 S. 1st Ave.
 Marshalltown, IA 50158-2823
 Phone: 800-338-8158 or
 Phone: 641-754-3771
 FAX: 641-754-3431
 e-mail: education@emersonprocess.com

Loop Schematics and Nameplates

This section includes loop schematics required for wiring of intrinsically safe installations. It also contains the approvals nameplates. If you have any questions, contact your Emerson Process Management sales office.

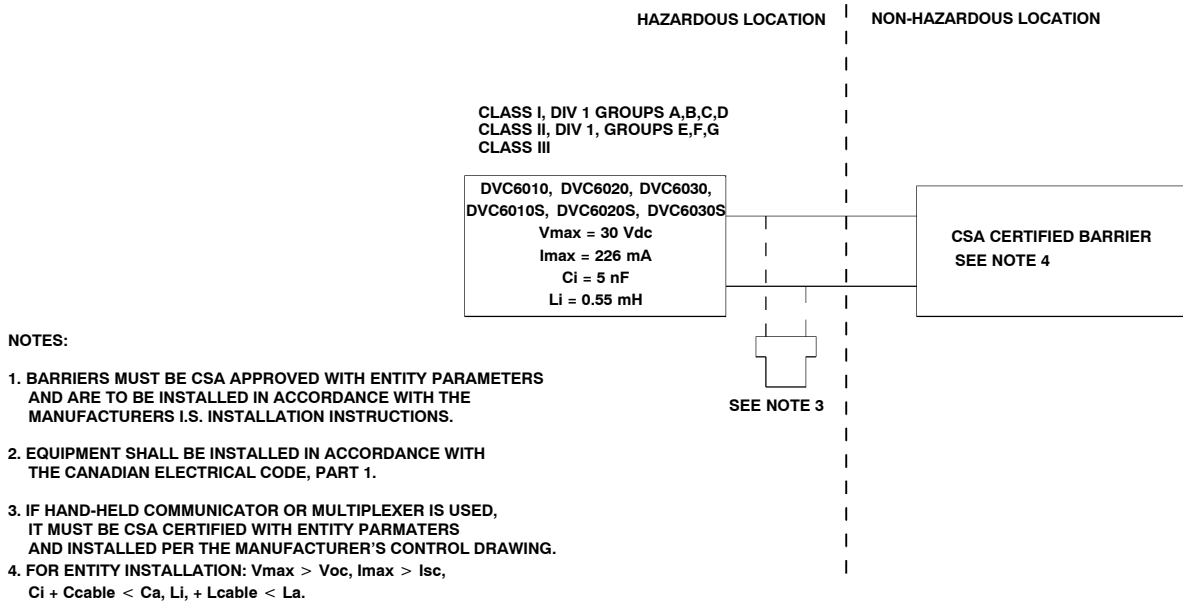

29B3428-C / DOC

Figure 5-1. CSA Schematic for Type DVC6000 and DVC6000S

<p>AMB TEMP: <input type="text"/> TO 80°C MAX VOLTAGE: 30 VDC --- CL I, DIV 1, GP BCD, T6; CL II, DIV 1.2, GP EFG, T6; CAUTION: KEEP COVER TIGHT WHILE CIRCUITS ARE ALIVE/ATTENTION: GARDER LE COUVERCLE BIEN FERME TANT QUE LES CIRCUITS SONT SOUS TENSION.</p>	<p>CL I, DIV 2, GP ABCD, T6; Ex ia INTRINSICALLY SAFE/SECURITE INTRINSEQUE; CL I,II,III, DIV 1, GROUPS PER DWG 29B3428, T5; WARNING: SUBSTITUTION OF COMPONENTS MAY IMPAIR INTRINSIC SAFETY /AVERTISSEMENT: LA SUBSTITUTION DE COMPOSANTS PEUT COMPROMETTRE LA SECURITE INTRINSEQUE. TYPE 4X, IP66, SEAL NOT REQUIRED; REFER TO MANUAL FOR MAX SUPPLY PRESSURE.</p>		
<p>SERIAL NO <input style="width: 150px;" type="text"/></p>	<p>INPUT DC --- <input style="width: 150px;" type="text"/></p>	<p>TYPE <input style="width: 100px;" type="text"/></p>	<p>GE05621</p>

TYPE DVC6010, DVC6020, DVC6030, DVC6010S, DVC6020S, DVC6030S

Figure 5-2. CSA Nameplate

DVC6000 Series

5

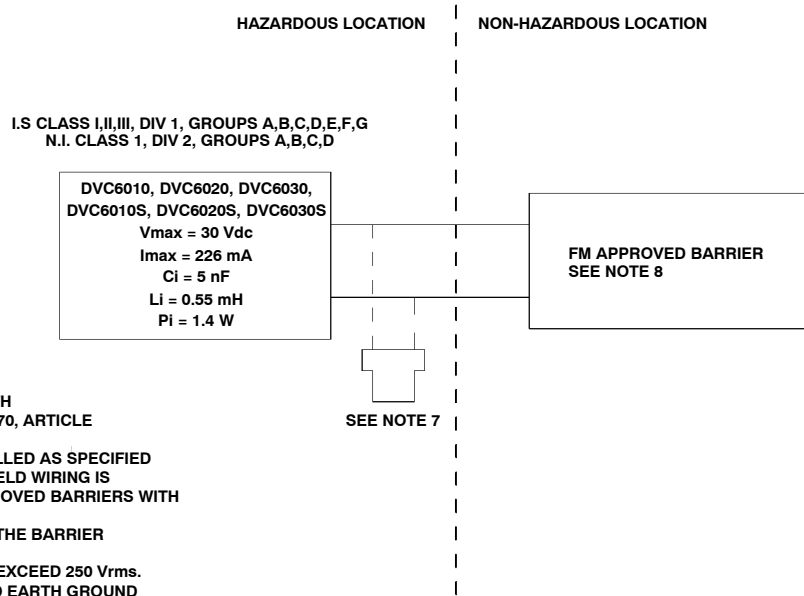



NOTES:

1. THE INSTALLATION MUST IN ACCORDANCE WITH THE NATIONAL ELECTRIC CODE (NEC), NFPA 70, ARTICLE 504 AND ANSI/ISA RP12.6.
2. CLASS 1, DIV 2 APPLICATIONS MUST BE INSTALLED AS SPECIFIED IN NEC ARTICLE 501-4(B). EQUIPMENT AND FIELD WIRING IS NON-INCENDIVE WHEN CONNECTED TO APPROVED BARRIERS WITH ENTITY PARAMETERS.
3. LOOPS MUST BE CONNECTED ACCORDING TO THE BARRIER MANUFACTURER'S INSTRUCTIONS.
4. MAXIMUM SAFE AREA VOLTAGE SHOULD NOT EXCEED 250 Vrms.
5. RESISTANCE BETWEEN BARRIER GROUND AND EARTH GROUND MUST BE LESS THAN ONE OHM.
6. NORMAL OPERATING CONDITIONS 30 Vdc 20 mADC.
7. IF HAND-HELD COMMUNICATOR OR MULTIPLEXER IS USED, IT MUST BE FM APPROVED AND INSTALLED PER THE MANUFACTURER'S CONTROL DRAWING.
8. FOR ENTITY INSTALLATION (I.S. AND N.I.):
 $V_{max} > V_{oc}, \text{ or } V_t$ $C_i + C_{cable} < C_a$
 $I_{max} > I_{sc}, \text{ or } I_t$ $L_i + L_{cable} < L_a$
 $P_i > P_o, \text{ or } P_t$

29B3427-B / DOC

Figure 5-3. FM Schematic for Type DVC6000 and DVC6000S

<p>AMB TEMP: <input type="text"/> TO 80°C MAX VOLTAGE: 30 VDC --- NEMA 4X, FACTORY SEALED USE FIELD WIRING SUITABLE FOR AT LEAST 90°C. REFER TO INSTRUCTION MANUAL FOR MAX SUPPLY PRESSURE.</p>	<p>XP CL I, DIV 1, GP BCD, T6; DI CL II, DIV 1, GP EFG, T6; S CL II, DIV 2, GP FG, T6; CAUTION: KEEP COVER TIGHT WHILE CIRCUITS ARE ALIVE. NI CL 1, DIV 2, GP ABCD, T6; IS CL I,II,III, DIV 1, GROUPS PER DWG 29B3427, T5; WARNING: SUBSTITUTION OF COMPONENTS MAY IMPAIR INTRINSIC SAFETY.</p>	  
<p>SERIAL NO <input style="width: 150px;" type="text"/></p>	<p>INPUT DC --- <input style="width: 150px;" type="text"/></p>	<p>TYPE <input style="width: 150px;" type="text"/></p>

TYPE DVC6010, DVC6020, DVC6030, DVC6010S, DVC6020S, DVC6030S

Figure 5-4. FM Nameplate

Loop Schematics and Nameplates

FISHER		LCIE 02 ATEX 6002X; EEx ia IIC T5(Tamb ≤ 80°C),T6(Tamb ≤ 75°C); IP66; Uj=30V, Ii=226mA, Pi=1.4W, Ci=5nF, Li=0.55mH; MAX ENCLOSURE SURFACE TEMP/TEMP MAX SURFACE BOITIER: T 85°C(Tamb ≤ 80°C). DISCONNECT POWER BEFORE OPENING/NE PAS OUVRIR SOUS TENSION. REFER TO MANUAL FOR MAX SUPPLY PRESSURE/ VOIR LE MANUEL POUR LA PRESSION ALIM MAX.		1180		II 1 G & D		GE05615	
AMB TEMP: <input type="text"/> TO 80°C		MAX VOLTAGE/TENSION: 30 VDC		HART FIELD COMMUNICATIONS PROTOCOL					
SERIAL NO SERIE NO <input type="text"/>		INPUT ENTREE DC <input type="text"/>		TYPE <input type="text"/>					

TYPE DVC6010, DVC6020, DVC6030, DVC6010S, DVC6020S, DVC6030S

Figure 5-5. ATEX Nameplate; Intrinsic Safety, Dust-Tight

FISHER		LCIE 02 ATEX 6001X; EEx d IIB+H2 T5(Tamb ≤ 85°C),T6(Tamb ≤ 75°C); IP66; MAX ENCLOSURE SURFACE TEMP/TEMP MAX SURFACE BOITIER: T 90°C(Tamb ≤ 85°C). DISCONNECT POWER BEFORE OPENING/NE PAS OUVRIR SOUS TENSION. REFER TO MANUAL FOR MAX SUPPLY PRESSURE/ VOIR LE MANUEL POUR LA PRESSION ALIM MAX.		1180		II 2 G & D		GE05613	
AMB TEMP: <input type="text"/> TO 85°C		MAX VOLTAGE/TENSION: 30 VDC		HART FIELD COMMUNICATIONS PROTOCOL		FOUNDATION			
SERIAL NO SERIE NO <input type="text"/>		INPUT ENTREE DC <input type="text"/>		TYPE <input type="text"/>					

TYPE DVC6010, DVC6020, DVC6030, DVC6010S, DVC6020S, DVC6030S

Figure 5-6. ATEX Nameplate; Flameproof, Dust-Tight

FISHER		LCIE 02 ATEX 6003X; EEx nCL IIC T5(Tamb ≤ 80°C); IP66; MAX ENCLOSURE SURFACE TEMP/TEMP MAX SURFACE BOITIER: T 85°C(Tamb ≤ 80°C). DISCONNECT POWER BEFORE OPENING/NE PAS OUVRIR SOUS TENSION. REFER TO MANUAL FOR MAX SUPPLY PRESSURE/ VOIR LE MANUEL POUR LA PRESSION ALIM MAX.		1180		II 3 G & D		GE05620	
AMB TEMP: <input type="text"/> TO 80°C		MAX VOLTAGE/TENSION: 30 VDC		HART FIELD COMMUNICATIONS PROTOCOL		FOUNDATION			
SERIAL NO SERIE NO <input type="text"/>		INPUT ENTREE DC <input type="text"/>		TYPE <input type="text"/>					

TYPE DVC6010, DVC6020, DVC6030, DVC6010S, DVC6020S, DVC6030S

Figure 5-7. ATEX Nameplate; Type n, Dust-Tight

DVC6000 Series

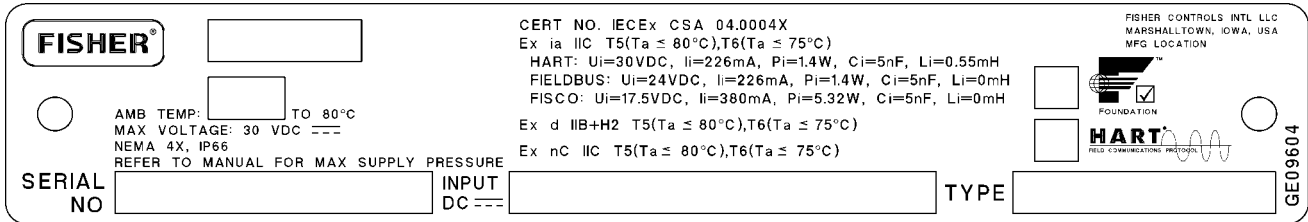

TYPE DVC6010, DVC6020, DVC6030, DVC6010S, DVC6020S, DVC6030S

Figure 5-8. IECEx Nameplate; Intrinsic Safety, Type n, Flameproof

5

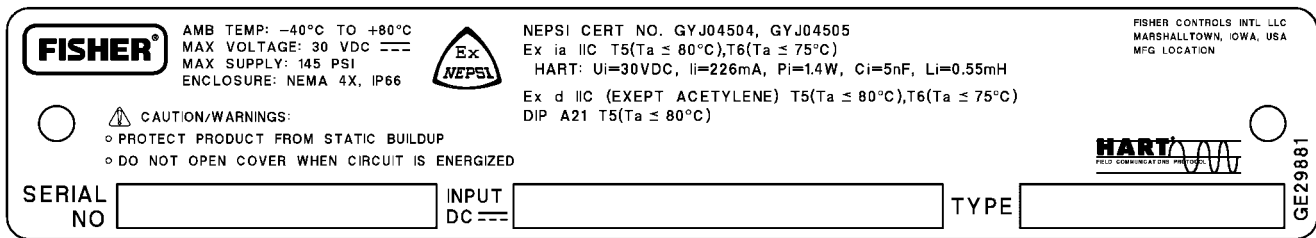

TYPE DVC6010, DVC6020, AND DVC6030

Figure 5-9. NEPSI Nameplate; Intrinsic Safety, Flameproof

Loop Schematics and Nameplates

DVC6000 Series

5



DVC6010 DIGITAL VALVE CONTROLLER
MOUNTED ON A SLIDING STEM
CONTROL VALVE / ACTUATOR



W8373

DVC6005 BASE UNIT AND DVC6025 FEEDBACK UNIT MOUNTED
ON A ROTARY CONTROL VALVE / ACTUATOR



W8115

DVC6020 DIGITAL VALVE
CONTROLLER MOUNTED ON A
ROTARY CONTROL VALVE / ACTUATOR



FIELDVUE, ValveLink, PlantWeb and Fisher are marks owned by Fisher Controls International LLC, a member of the Emerson Process Management business division of Emerson Electric Co. Emerson Process Management, Emerson and the Emerson logo are trademarks and service marks of Emerson Electric Co. AMS and Tri-Loop are marks owned by one of the Emerson Process Management group of companies. HART is a mark owned by the HART Communication Foundation. All other marks are the property of their respective owners. This product may be covered under one or more of the following patents (5,163,463; 5,265,637; 5,381,817; 5,434,774; 5,439,021; 5,451,923; 5,502,999; 5,532,925; 5,533,544; 5,549,137; 5,558,115; 5,573,032; 5,687,098) or under pending patents.

The contents of this publication are presented for informational purposes only, and while every effort has been made to ensure their accuracy, they are not to be construed as warranties or guarantees, express or implied, regarding the products or services described herein or their use or applicability. We reserve the right to modify or improve the designs or specifications of such products at any time without notice.

Neither Emerson, Emerson Process Management, nor any of their affiliated entities assumes responsibility for the selection, use and maintenance of any product. Responsibility for the selection, use and maintenance of any product remains with the purchaser and end-user.

Emerson Process Management

Marshalltown, Iowa 50158 USA

Cernay 68700 France

Sao Paulo 05424 Brazil

Singapore 128461

www.Fisher.com

