

DVC2000 Series

FIELDVUE[®] DVC2000 Series Digital Valve Controllers

Introduction	1
Installation	2
Basic Setup and Calibration	3
Advanced Setup and Calibration	4
Maintenance	5
Replaceable Parts	6

Appendices

Specifications	A
Principle of Operation	B
Model 375 Field Communicator Basics	C
Loop Schematics/Nameplates	D

Glossary

Glossary

Index

Index

This manual applies to:

<i>DVC2000 Series</i>			<i>Model 375 Field Communicator</i>	<i>Model 275 HART[®] Communicator</i>	
<i>Device Revision</i>	<i>Firmware Revision</i>	<i>Hardware Revision</i>	<i>Device Description Revision</i>	<i>Device Description Revision</i>	<i>Memory Module (Mb)</i>
1	1 & 2	1	1	1	4, 8 & 12



DVC2000 Series

Model 375 Field Communicator Fast-Key Sequence (DVC2000 Series Instrument Level AC)

Function/Variable	Fast-Key Sequence	Coordinates ⁽¹⁾	Function/Variable	Fast-Key Sequence	Coordinates ⁽¹⁾
Analog Input Calibration	1-3-1	3-E	Integral Gain	1-2-3-6-2	5-F
Analog Input Units	1-2-2-1	4-E	Integral Settings	1-2-3-6	5-F
Auto Calibrate Travel	1-3-2	3-E	LUI Language	1-2-1-8	4-E
Auto Setup	1-1-1	3-B	LUI Pressure Units	1-2-2-5	4-E
Auto Tuner	1-1-1-3	3-B	Manual Calibrate Travel	1-3-3	3-E
Basic Setup	1-1	2-B	Manual Setup	1-1-2	3-C
Calibrate	1-3	3-E	Measured Variable	1-2-2	4-E
Damping Factor	1-1-1-4-2	4-B	Main Electronics Revision	2-1-5	3-F
Date	1-2-1-4	4-D	Maximum Supply Pressure	1-1-2-2-3	4-C
Descriptor	1-2-1-3	4-D	Message	1-2-1-2	4-D
Detailed Setup	1-2	3-D	Polling Address	1-2-1-7	4-E
Device Description Revision	2-2	2-E	Pressure Units	1-2-2-4	4-E
Device Identification	2-1-9	3-F	Protection	Hot Key	1-A
Device Information	2-1	3-F	Secondary Electronics Revision	2-1-6	3-F
Device Revision	2-1-2	3-F	Sensor Serial Number	2-1-7	3-F
Display	2	2-E	Setup Wizard	1-1-1-1	3-B
Enable Integral Control	1-2-3-6-1	5-F	Switch 1 Closed ⁽²⁾	1-2-4-2	4-G
Expert Tuning Gains	1-1-1-4-3	5-B	Switch 1 Trip Point ⁽²⁾	1-2-4-1	4-G
Firmware Date	2-1-4	3-F	Switch 2 Closed ⁽²⁾	1-2-4-4	4-G
Firmware Revision	2-1-3	3-F	Switch 2 Trip Point ⁽²⁾	1-2-4-3	4-G
HART Tag	1-2-1-1	4-D	Transmitter Action ⁽²⁾	1-2-4-5	4-G
HART Universal Revision	2-1-1	3-F	Transmitter Calibration ⁽²⁾	1-3-4	3-E
Input Characterization	1-2-3-4	4-F	Travel Cutoff High	1-2-3-5-1	5-F
Input Range High	1-2-2-2	4-E	Travel Cutoff Low	1-2-3-5-2	5-F
Input Range Low	1-2-2-3	4-E	Tuning	Hot Key	1-A
Instrument Level	2-1-8	3-F	Tuning Set	1-1-1-4-1	4-B
Instrument Mode	Hot Key	1-A	Valve Serial Number	1-2-1-5	4-D
Instrument Serial Number	1-2-1-6	4-E	Zero Control Signal	1-1-2-2-4	4-C
Integral Dead Zone	1-2-3-6-3	5-F			

- Coordinates are to help locate the item on the menu structure on the following page.
- Available only if the instrument has a transmitter and limit switches installed.

**(Unfold this sheet to see
the Local Interface
Flow Chart)**

DVC2000 Series

Local Interface Flow Chart

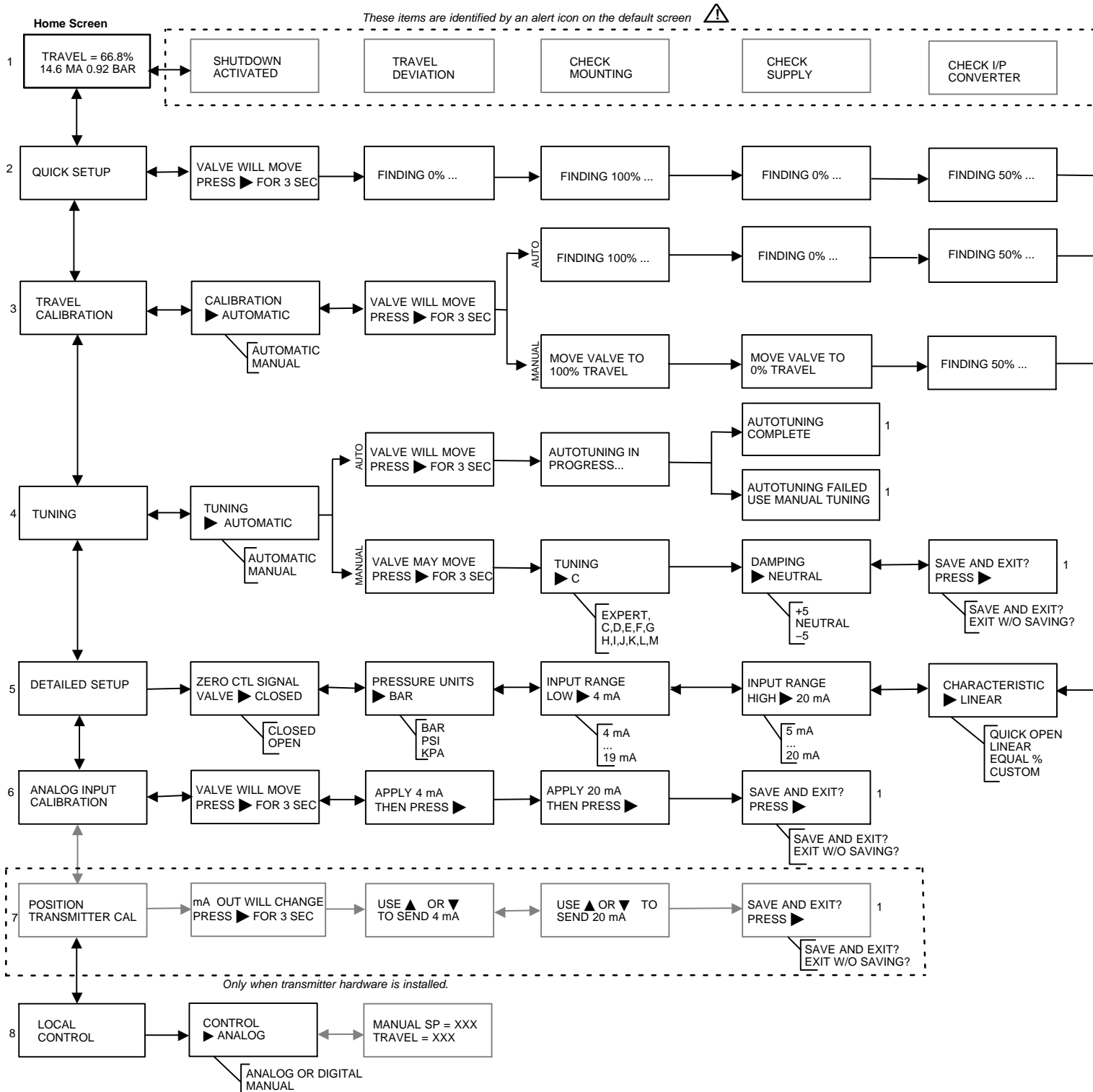

DVC2000 Series

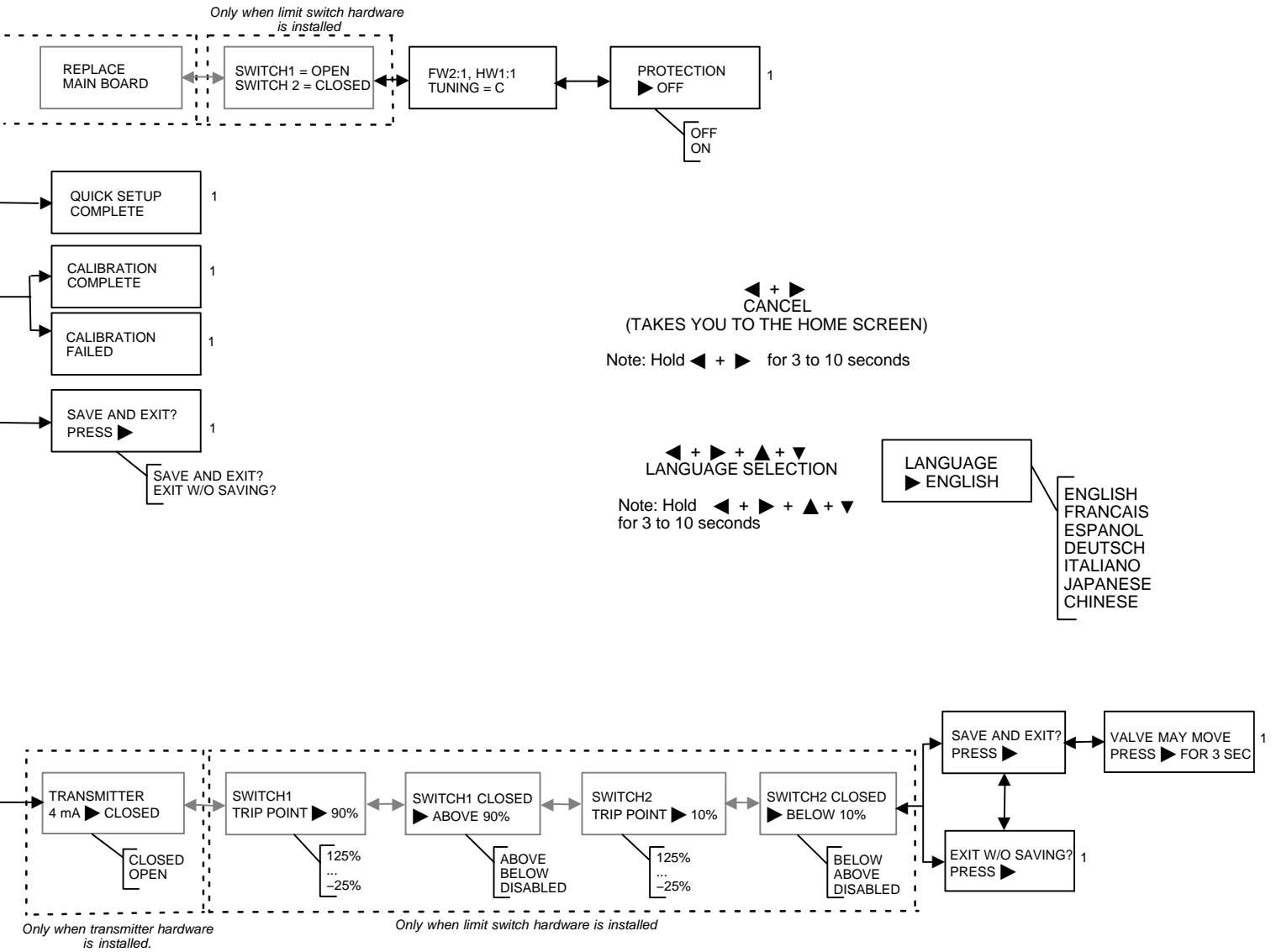

DVC2000 Series

Model 375 Field Communicator Menu Structure for FIELDVUE® DVC2000 Instrument Level AC

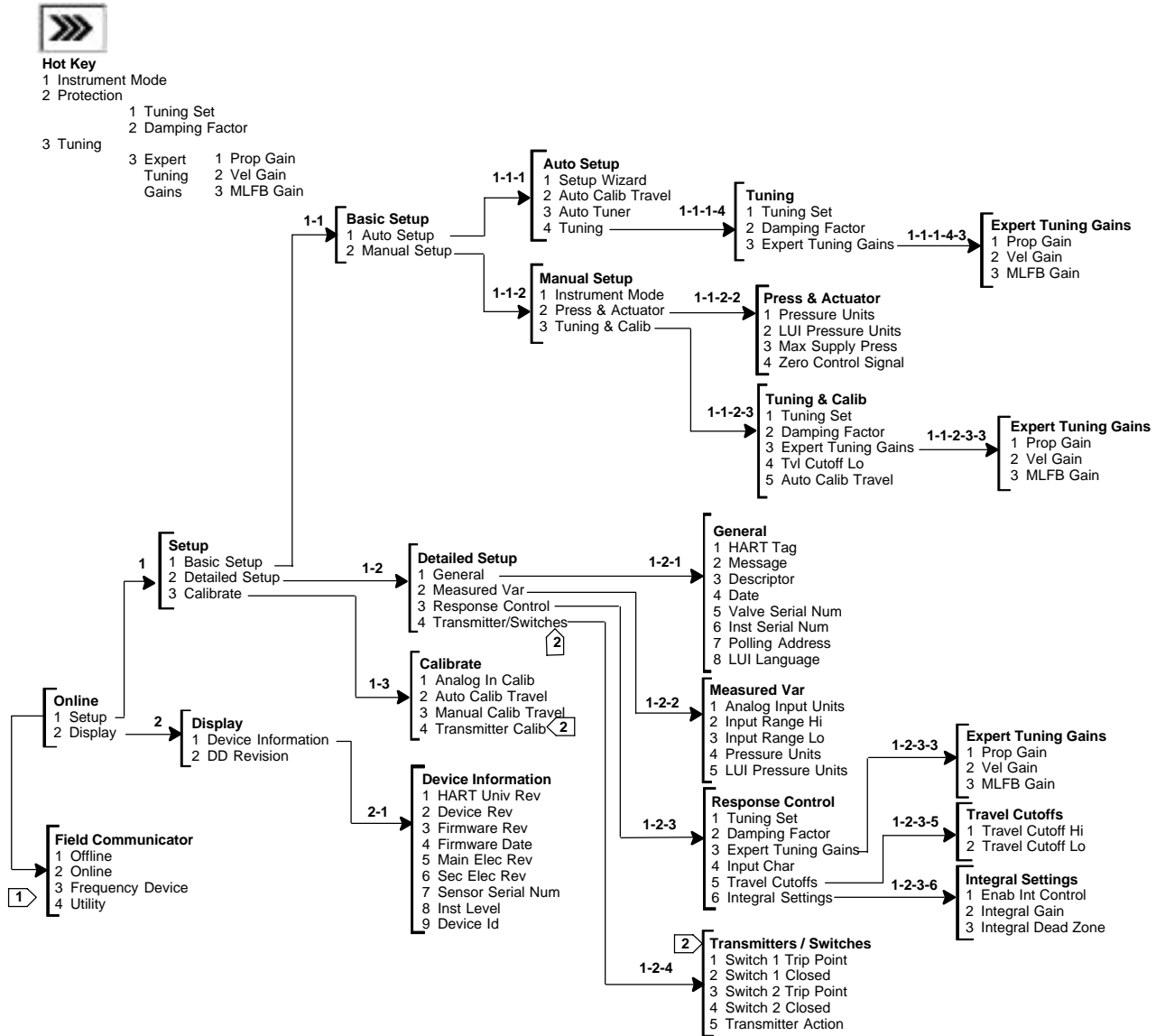

Notes:

① This menu is available by pressing the left arrow key from the previous menu.

② Available only if the instrument has a transmitter and limit switches installed.

A
—
B
—
C
—
D
—
E
—
F
—
G
—
H
—
I

DVC2000 Series

Model 375 Field Communicator Fast-Key Sequence (DVC2000 Series Instrument Level HC, AD and PD)

Function/Variable	Fast-Key Sequence	Coordinates ⁽¹⁾	Function/Variable	Fast-Key Sequence	Coordinates ⁽¹⁾
Actuator Style	1-2-5-2	4-E	Minimum Closing Time	1-2-6-8-2	5-E
Alert Record	1-2-7-6	4-G	NVM Fail	1-2-8-5	4-H
Analog Input	2	1-E	Operational Status	7-3	2-F
Analog Input Calibration	1-4-1	2-E	Polling Address	1-2-3-7	4-D
Analog Input Range High	1-2-4-2	4-D	Pressure	6	1-E
Analog Input Range Low	1-2-4-3	4-E	Pressure Calibration	1-4-4	2-E
Analog Input Units	1-2-4-1	4-D	Pressure Sensor Failure	1-2-8-7	4-H
Auto Calibrate Travel	1-4-2	2-E	Pressure Units	1-2-4-4	4-E
Auto Setup	1-1-1	2-B	Protection	Hot Key	1-A
Auto Tuner	1-1-1-3	3-B	Reference Voltage Failure	1-2-8-3	4-H
Basic Setup	1-1	2-B	Response Control	1-2-6	4-F
Burst	1-2-1-5	4-C	Restart	1-2-1-4	3-C
Calibrate	1-4	2-E	Restart Control Mode	1-2-1-3	3-C
Control Mode	1-2-1-2	3-C	Secondary Electronics Revision	1-3-2-6	2-H
Custom Characteristic Table	1-2-6-5	4-F	Self Test Shutdown	1-2-8	3-D
Cycle Count	1-2-7-4-4	5-H	Sensor Serial Number	1-3-2-7	2-H
Cycle Count Alert	1-2-7-4	5-H	Set Point Filter Time	1-2-6-6	4-F
Cycle Count Alert Enable	1-2-7-4-1	5-H	Setup Wizard	1-1-1-1	3-B
Cycle Count Alert Point	1-2-7-4-2	5-H	Stroke Valve	1-5	1-D
Cycle Count Deadband	1-2-7-4-3	5-H	Switch 1 Closed ⁽²⁾	1-2-9-2	4-I
Damping Factor	1-1-2-3-2	4-C	Switch 1 Trip Point ⁽²⁾	1-2-9-1	4-I
Date	1-2-3-4	4-D	Switch 2 Closed ⁽²⁾	1-2-9-4	4-I
Descriptor	1-2-3-3	4-D	Switch 2 Trip Point ⁽²⁾	1-2-9-3	4-I
Device Description Revision	1-3-3	2-D	Temperature	1-3-1-1	2-G
Device Identification	1-3-2-9	2-I	Temperature Comp Fail	1-2-8-2	4-H
Device Information	1-3-2	2-D	Temperature Sensor Failure	1-2-8-6	4-H
Device Revision	1-3-2-2	2-H	Temperature Units	1-2-4-6	4-E
Drive Alert Enable	1-2-7-5-1	5-I	Transmitter Action ⁽²⁾	1-2-9-5	4-I
Drive Current Fail	1-2-8-4	4-H	Transmitter Calibration ⁽²⁾	1-4-6	2-E
Drive Signal	5	1-E	Travel	3	1-E
Enable Integral Control	1-2-6-9-1	5-F	Travel Accumulator	1-2-7-3-4	5-H
Expert Tuning Gains	1-1-1-4-3	5-B	Travel Accumulator Alert Enable	1-2-7-3-1	5-H
Failure Alerts	7-2	2-F	Travel Accumulator Alert Point	1-2-7-3-2	5-H
Failure Group Enable	1-2-7-6-4-2	6-I	Travel Accumulator Dead Band	1-2-7-3-3	5-H
Firmware Date	1-3-2-4	2-H	Travel Alert Deadband	1-2-7-1-7	6-G
Firmware Revision	1-3-2-3	2-H	Travel Alert High Point	1-2-7-1-3	6-G
Flash Rom Failure	1-2-8-1	4-H	Travel Alert High High Point	1-2-7-1-5	6-G
HART Tag	1-2-3-1	4-C	Travel Alert Low Point	1-2-7-1-4	6-G
HART Universal Revision	1-3-2-1	2-H	Travel Alert Low Low Point	1-2-7-1-6	6-G
Input Characterization	1-2-6-4	4-F	Travel Cutoff Low	1-2-6-7-4	5-E
Instrument Level	1-3-2-8	2-H	Travel Cutoff High	1-2-6-7-3	5-E
Instrument Mode	Hot Key	1-A	Travel Deviation Alert Enable	1-2-7-2-1	5-G
Instrument Serial Number	1-2-3-6	4-D	Travel Deviation Alert Point	1-2-7-2-2	5-G
Instrument Status	7	1-E	Travel Deviation Time	1-2-7-2-3	5-G
Integral Dead Zone	1-2-6-9-3	5-F	Travel High / Low Enable	1-2-7-1-1	6-G
Integral Gain	1-2-6-9-2	5-F	Travel High High / Low Low Enable	1-2-7-1-2	6-G
Integral Settings	1-2-6-9	5-F	Travel Limit High	1-2-6-7-1	5-E
Limit Switch Stat Enable	1-2-7-6-4-3	6-I	Travel Limit Low	1-2-6-7-2	5-E
LUI Language	1-2-3-8	4-D	Travel Sensor Failure	1-2-8-8	4-H
LUI Pressure Units	1-2-4-5	4-E	Travel Setpoint	4	1-E
Main Electronics Revision	1-3-2-5	2-H	Tuning	Hot Key	1-A
Manual Calibrate Travel	1-4-3	2-E	Tuning Set	1-1-2-3-1	4-C
Manual Setup	1-1-2	3-B	Valve Group Enable	1-2-7-6-4-1	6-I
Maximum Supply Pressure	1-2-5-1	4-B	Valve Style	1-2-5-3	4-E
Message	1-2-3-2	4-D	Valve Serial Number	1-2-3-5	4-D
Minimum Opening Time	1-2-6-8-1	5-E	Zero Control Signal	1-2-5-4	4-E

1. Coordinates are to help locate the item on the menu structure on the following page.
 2. Available only if the instrument has a transmitter and limit switches installed.

DVC2000 Series

Model 375 Field Communicator Menu Structure for FIELDVUE® DVC2000 Instrument Levels HC, AD and PD



Hot Key

- 1 Instrument Mode
- 2 Protection

3 Tuning

- 1 Tuning Set
- 2 Damping Factor
- 3 Expert Tuning Gains
 - 1 Prop Gain
 - 2 Vel Gain
 - 3 MLFB Gain

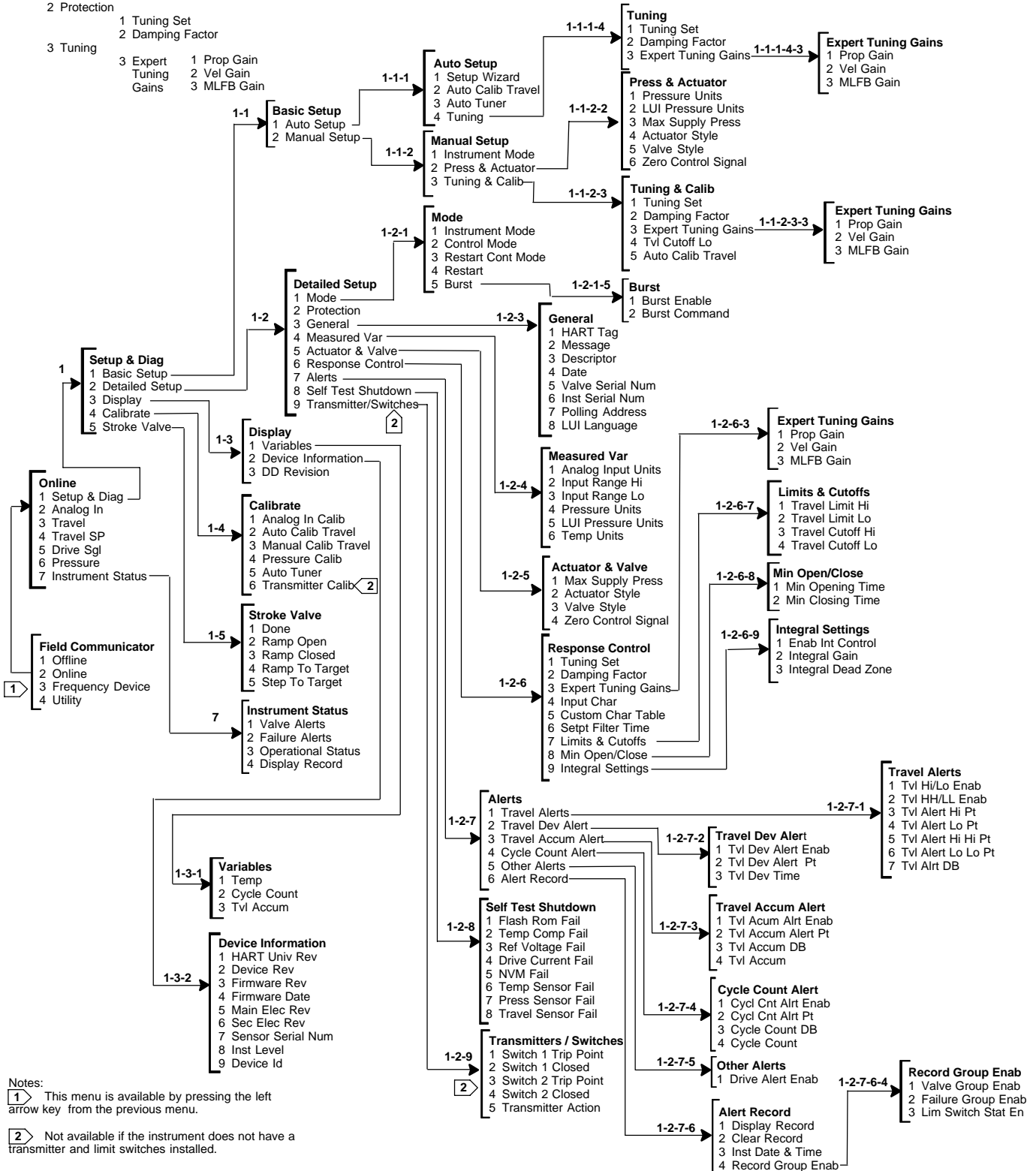

A

B

C

D

E

F

G

H

I

Notes:

1 This menu is available by pressing the left arrow key from the previous menu.

2 Not available if the instrument does not have a transmitter and limit switches installed.

1

2

3

4

5

6

DVC2000 Series



W8861



THE FIELDVUE[®] DVC2000 SERIES DIGITAL VALVE CONTROLLER IS A CORE COMPONENT OF THE PLANTWEB DIGITAL PLANT ARCHITECTURE. THE DIGITAL VALVE CONTROLLER POWERS PLANTWEB BY CAPTURING AND DELIVERING VALVE DIAGNOSTIC DATA. COUPLED WITH AMS VALVELINK[®] SOFTWARE, THE DVC2000 PROVIDES USERS WITH AN ACCURATE PICTURE OF VALVE PERFORMANCE, INCLUDING ACTUAL STEM POSITION, INSTRUMENT INPUT SIGNAL AND PNEUMATIC PRESSURE TO THE ACTUATOR. USING THIS INFORMATION, THE DIGITAL VALVE CONTROLLER DIAGNOSES NOT ONLY ITSELF, BUT ALSO THE VALVE AND ACTUATOR TO WHICH IT IS MOUNTED.

FIELDVUE[®] DVC2000 Series Digital Valve Controller, and
Design GX Control Valve and Actuator

Section 1 Introduction

1

Instrument Description	1-2
Terminology	1-2
Scope of Manual	1-2
Specifications	1-3
Related Documents	1-3
Educational Services	1-3

DVC2000 Series

Instrument Description

DVC2000 Series digital valve controllers are communicating, microprocessor-based current-to-pneumatic valve positioners (see figure 1-1). They are designed to replace standard pneumatic and electro-pneumatic valve positioners.

1

In addition to the traditional function of converting an input current signal (4–20mA) to a pneumatic output pressure, the DVC2000 Series digital valve controllers communicate via a local display panel and/or via the HART® protocol. An option is available which provides isolated circuitry for two (2) integrated limit switches (for open/close valve indication) and a valve position transmitter (for separate valve position feedback).



W8755

Figure 1-1. Type DVC2000 Series Digital Valve Controller

Terminology

Instrument Level— There are four (4) levels of functionality available: AC, HC, AD and PD.

AC— This level provides the capability to setup and calibrate the positioner through the LCD or the 375 Field Communicator.

HC— This level provides additional capability for advanced configuration of the positioner (such as travel limits/cutoffs, custom characterization, and minimum open/closing time). Also, information is available through the HART protocol for diagnostic alerts such as travel deviation, cycle count, and travel accumulation.

AD— This level provides advanced diagnostic capabilities for performance testing. When used with AMS ValveLink Software, instrument health can be evaluated with tests such as Valve Signature, step response and dynamic error band. The software program provides detailed analysis with graphics.

PD— This level provides automated, non-intrusive testing of the operating performance of the control valve assembly. When used with AMS ValveLink® Software, tests to isolate component degradation can be run on the valve assembly without affecting the process.

Local Interface— All DVC2000 Series digital valve controllers come standard with a Liquid Crystal Display (LCD) and four (4) pushbuttons. The local interface provides the capability to setup and calibrate the positioner and view basic diagnostic messages.

Magnet Assembly— This is the feedback component that is mounted directly to the valve stem. It supplies a magnetic field that is sensed by the digital valve controller.

Option Boards— The DVC2000 Series digital valve controller is available with two (2) limit switches and a valve position transmitter. The option boards include the additional circuitry and terminations that are required to support these output signals.

Pole Piece— Inserted into the DVC2000 housing and protruding through the back of the instrument is a two-pronged fork that houses the magnetic sensor for position feedback.

Scope of Manual

This instruction manual includes specifications, installation, initial setup, configuration, operation, troubleshooting, and maintenance information for DVC2000 Series digital valve controllers.

This manual describes using the Model 375 Field Communicator to setup and calibrate the instrument. To accomplish these functions, as well as diagnostic and performance tests with AMS ValveLink Software, refer to the AMS ValveLink Software help.

No person may install, operate, or maintain a DVC2000 Series digital valve controller without first ● being fully trained and qualified in valve, actuator and accessory installation, operation and maintenance, and ● carefully reading and understanding the contents of this manual. If you have any questions regarding these instructions, contact your Fisher® sales office before proceeding.



Note

Neither Emerson™, Emerson Process Management, Fisher, nor any of their affiliated entities assumes responsibility for the selection, use and maintenance of any product. Responsibility for the selection, use and maintenance of any product remains with the purchaser and end-user.

Specifications

Specifications for the DVC2000 Series digital valve controller are shown in Appendix A, Specifications. Specifications for the Field Communicator can be found in the 375 Field Communicators User's Manual.



WARNING

This product is intended for a specific range of application specifications. Incorrect configuration of a positioning instrument could result in the malfunction of the product, property damage, or personal injury.

Related Documents

Other documents containing information related to the DVC2000 Series digital valve controller include:

- FIELDVUE® DVC2000 Series Digital Valve Controller (Bulletin 62.1:DVC2000)
- FIELDVUE® DVC2000 Series Digital Valve Controllers Quick Start Guide – Form 5789
- Using the FIELDVUE® Instruments with the Smart HART® Loop Interface and Monitor (HIM) (PS Sheet 62.1:FIELDVUE(L))

These documents are available from your Fisher sales office. Also visit our website at www.FIELDVUE.com.

Educational Services

For information on available courses for the DVC2000 Series digital valve controller, as well as a variety of other products, contact:

Emerson Process Management
Educational Services, Registration
P.O. Box 190; 301 S. 1st Ave.
Marshalltown, IA 50158-2823
Phone: 800-338-8158 or
Phone: 641-754-3771
FAX: 641-754-3431
e-mail: education@emersonprocess.com

Section 2 Installation

Valve and Actuator Mounting 2-2

 Air-to-Open Sliding Stem (Linear) Actuators (e.g. Fisher Type 667) 2-3

 Air-to-Close Sliding Stem (Linear) Actuators (e.g. Fisher Type 657) 2-4

 Air-to-Open Fisher Type GX Actuators 2-5

 Air-to-Close Fisher Type GX Actuators 2-6

 Guidelines for Mounting on Quarter-Turn (Rotary) Actuators 2-6

Electrical and Pneumatic Connections 2-8

 Supply Connections 2-8

 Electrical Connections 2-9

 Limit Switches 2-9

 Position Transmitter 2-9

 Vent 2-10

 Communication Connections 2-10

DVC2000 Series

Valve / Actuator Mounting

2



Note

The DVC2000 is not designed to correct for significant stem rotation on sliding stem actuators.



WARNING

Avoid personal injury or property damage from sudden release of process pressure or bursting of parts. Before mounting the DVC2000 Series digital valve controller:

- Always wear protective clothing and eyewear when performing any installation procedures to avoid personal injury.
- Disconnect any operating lines providing air pressure, electric power, or a control signal to the actuator. Be sure the actuator cannot suddenly open or close the control valve.
- Use bypass valves or completely shut off the process to isolate the control valve from process pressure. Relieve process pressure from both sides of the control valve. Drain the process media from both sides of the control valve.
- Vent the pneumatic actuator loading pressure and relieve any actuator spring precompression.
- Use lock-out procedures to be sure that the above measures stay in effect while you work on the equipment.
- Check with your process or safety engineer for any additional measures that must be taken to protect against process media.

If ordered as a part of a control valve assembly, the factory will mount the digital valve controller on the actuator and calibrate the instrument. If you purchased the digital valve controller separately, you will need a mounting kit to mount the digital valve controller on the

actuator. The following procedures are general guidelines you should consider when mounting the digital valve controller. See the instructions that come with the mounting kit for detailed information on mounting the digital valve controller to a specific actuator model.

The DVC2000 housing is available in four different configurations, depending on the actuator mounting method and threaded connection style. Figure 2-1 shows the available configurations.

The feedback system for the Type DVC2000 Series digital valve controller utilizes a magnetic field for true linkage-less, non-contacting position measurement. In order to prevent inadvertent stem movement while the instrument is in operation, magnetic tools (such as a magnetic-tipped screwdriver) should not be used.

CAUTION

The magnet material has been specifically chosen to provide a long-term stable magnetic field. However, as with any magnet, care must be taken when handling the magnet assembly. Another high powered magnet placed in close proximity (less than 25 mm) can cause permanent damage. Potential sources of damaging equipment: transformers, DC motors, stacking magnet arrays, magnetic tipped screwdrivers.



Note

As a general rule, do not use less than 50% of the magnet array for full travel measurement. Performance will decrease gradually as the array is increasingly subranged.

The linear magnet arrays have a valid travel range indicated by arrows molded into the piece. This means that the hall sensor (on the back of the DVC2000 housing) has to remain within this range throughout the entire valve travel. See figure 2-2.

The linear magnet arrays are symmetrical. Either end may be up.

HOUSINGS FOR LINEAR AND ROTARY ACTUATORS

CONNECTIONS AVAILABLE:
 • M20 CONDUIT AND G1/4 PNEUMATIC
 • 1/2-INCH NPT CONDUIT AND 1/4-INCH NPT PNEUMATIC

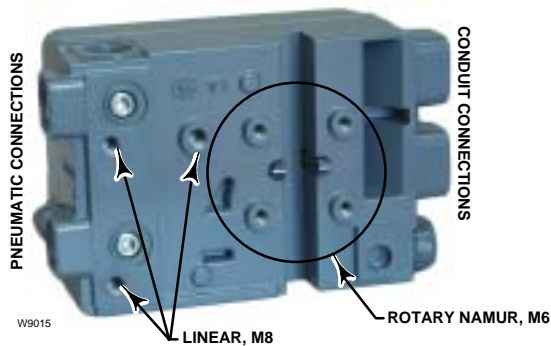

HOUSINGS FOR FISHER TYPE GX ACTUATORS

CONNECTIONS AVAILABLE:
 • M20 CONDUIT AND G1/4 PNEUMATIC
 • 1/2-INCH NPT CONDUIT AND 1/4-INCH NPT PNEUMATIC

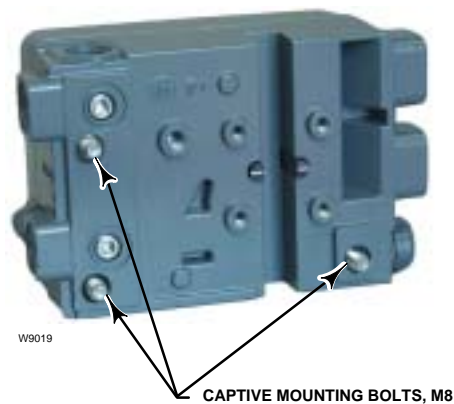

2

Figure 2-1. DVC2000 Housing Variations

There are a variety of mounting brackets and kits that are used to mount the DVC2000 to different actuators. However, despite subtle differences in fasteners, brackets, and connecting linkages, the procedures for mounting can be categorized as follows:

- Air-to-open sliding stem (linear) actuators.
- Air-to-close sliding stem (linear) actuators.
- Air-to-open Fisher GX actuator.
- Air-to-close Fisher GX actuator.
- Rotary actuators with travel up to 90 degrees.

See figure 2-3 for the different travel feedback magnet pieces.

Air-to-Open Sliding Stem (Linear) Actuators (e.g. Fisher Type 667)

WARNING

Refer to the Installation WARNING at the beginning of this section.

1. Attach the mounting bracket to the actuator.

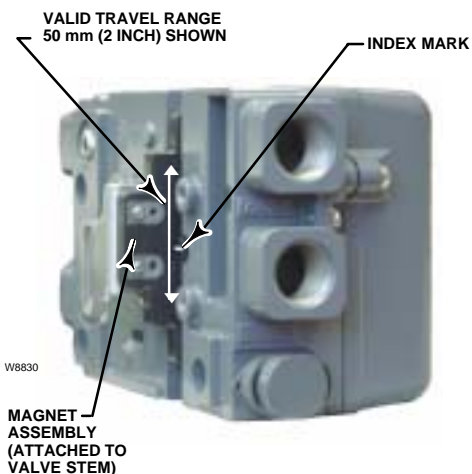

Figure 2-2. Travel Range

2. Loosely attach the feedback pieces and magnet assembly to the valve stem connector. Do not tighten the fasteners because fine adjustment is required.

CAUTION

Do not install a magnet array that is shorter than the physical travel of the actuator. Loss of control will result from the magnet array moving outside the range of the index mark in the feedback slot of the DVC2000 housing.

DVC2000 Series

2

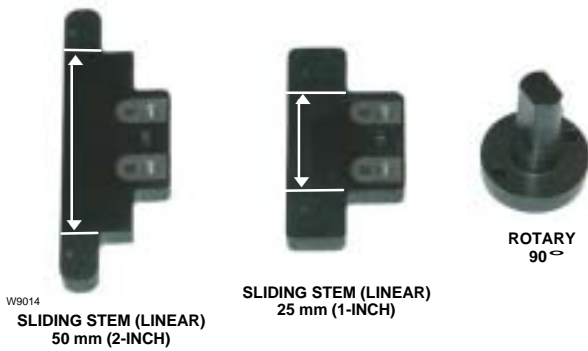

NOTE: VALID TRAVEL RANGE INDICATED BY WHITE ARROWS

Figure 2-3. Magnet Assemblies

3. Using the alignment tool (supplied with the mounting kit), position the feedback array inside the retaining slot.
4. Find the mark on the **lower** travel scale that corresponds with the actual valve travel. See figure 2-4.
5. Vertically align the magnet array such that the nominal valve travel is lined up with the **lower** extreme of the valid travel range on the feedback array
6. Tighten the bolts and remove the alignment tool.
7. Mount the digital valve controller to the mounting bracket, using the mounting bolts. See figure 2-6.
8. Check for clearance between the magnet assembly and the DVC2000 feedback slot. The magnet assembly should be positioned such that the index mark in the feedback slot of the DVC2000 housing is between the valid range on the magnet assembly throughout the range of travel. See figure 2-2.
9. Install tubing between the actuator casing and the pneumatic positioner output connection that has the arrow pointing away from the opening. See figure 2-7.

Air-to-Close Sliding Stem (Linear) Actuators (e.g. Fisher Type 657)

WARNING

Refer to the Installation WARNING at the beginning of this section.

1. Attach the mounting bracket to the actuator.
2. Loosely attach the feedback pieces and magnet assembly to the valve stem connector. Do not tighten the fasteners because fine adjustment is required.

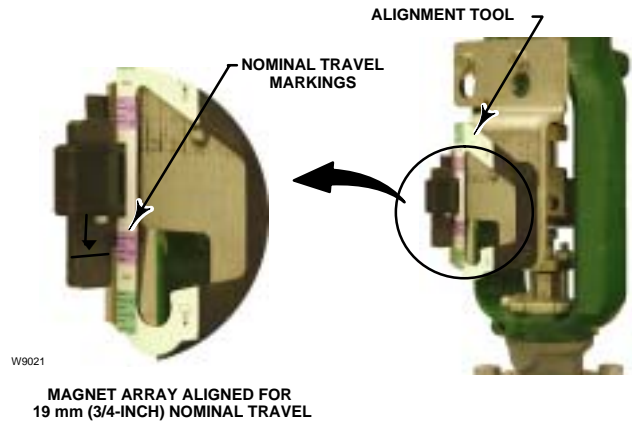

Figure 2-4. Air-to-Open Magnet Array Alignment

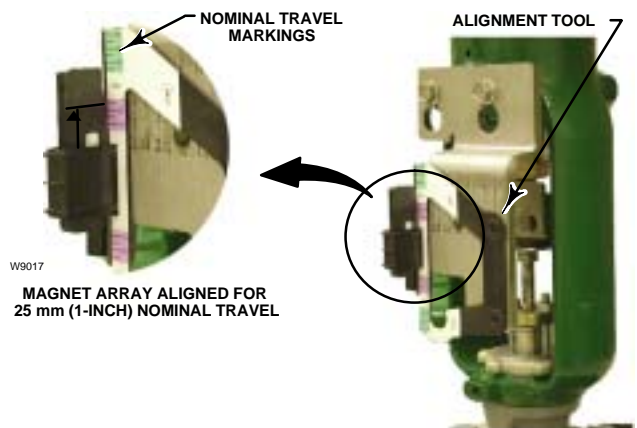

Figure 2-5. Air-to-Close Magnet Array Alignment

CAUTION

Do not install a magnet array that is shorter than the physical travel of the actuator. Loss of control will result from the magnet array moving outside the range of the index mark in the feedback slot of the DVC2000 housing.

3. Using the alignment tool (supplied with the mounting kit), position the feedback array inside the retaining slot.
4. Find the mark on the **upper** travel scale that corresponds with the actual valve travel. See figure 2-5.

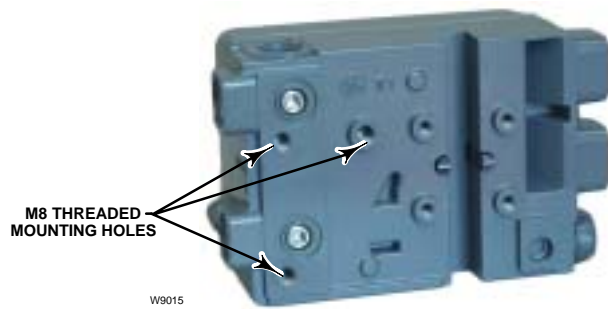

Figure 2-6. Mounting Holes for Linear Actuators

5. Vertically align the magnet array such that the nominal valve travel is lined up with the **upper** extreme of the valid travel range on the feedback array.
6. Tighten the bolts and remove the alignment tool.
7. Mount the digital valve controller to the mounting bracket, using the mounting bolts. See figure 2-6.
8. Check for clearance between the magnet assembly and the DVC2000 feedback slot. The magnet assembly should be positioned such that the index mark in the feedback slot of the DVC2000 housing is between the valid range on the magnet assembly throughout the range of travel. See figure 2-2.
9. Install tubing between the actuator casing and the pneumatic positioner output connection that has the arrow pointing away from the opening. See figure 2-7.

Air-to-Open Fisher Type GX Actuators

WARNING

Refer to the Installation WARNING at the beginning of this section.

The DVC2000 digital valve controller mounts directly on the Fisher Type GX actuator without the need for a mounting bracket.

1. Loosely attach the feedback pieces and magnet assembly to the valve stem connector. Do not tighten the fasteners because fine adjustment is required.

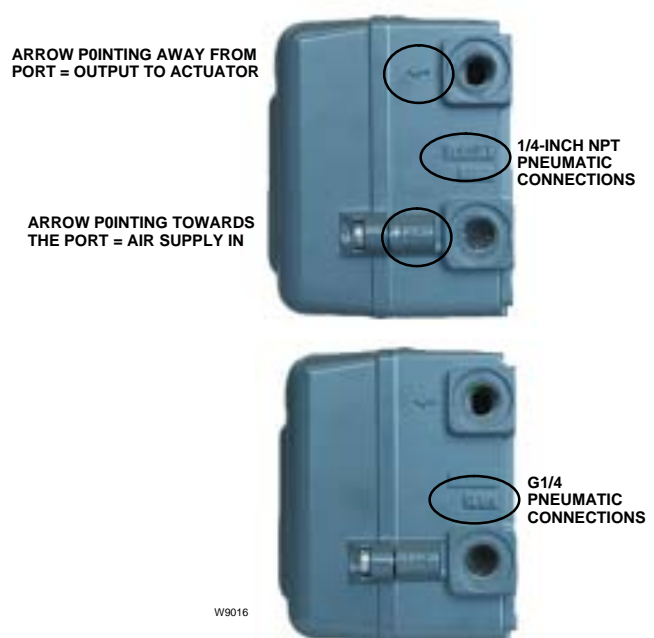

Figure 2-7. Conduit and Pneumatic Thread Variations

CAUTION

Do not install a magnet array that is shorter than the physical travel of the actuator. Loss of control will result from the magnet array moving outside the range of the index mark in the feedback slot of the DVC2000 housing.

2. Using the alignment tool (supplied with the mounting kit), position the feedback array inside the retaining slot.
3. Find the mark on the **lower** travel scale that corresponds with the actual valve travel. See figure 2-8.
4. Vertically align the magnet array such that the nominal valve travel is lined up with the **lower** extreme of the valid travel range on the feedback array.
5. Tighten the bolts and remove the alignment tool.
6. Remove the top plug (R1/8) from the back of the DVC2000 housing. This pneumatic output port on the DVC2000 lines up with the integral GX actuator pneumatic port. See figure 2-10.
7. Install the plug (either G1/4 or 1/4NPT, included in the mounting kit) to the external output pneumatic port.
8. Remove the digital valve controller's cover.

DVC2000 Series

2

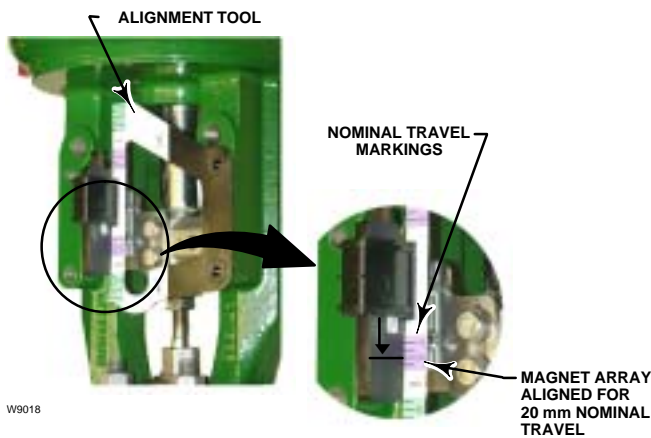

Figure 2-8. Air-to-Open Fisher GX Magnet Array Alignment

9. Using a 6 mm hex wrench, attach the digital valve controller to the GX actuator mounting pad on the side that has the open pneumatic port. Be sure to place the O-ring between the digital valve controller's pneumatic output and the actuator mounting pad. Pneumatic tubing is not required because the air passages are internal to the actuator.

10. Check for clearance between the magnet assembly and the DVC2000 feedback slot. The magnet assembly should be positioned such that the index mark in the feedback slot of the DVC2000 housing is between the valid range on the magnet assembly throughout the range of travel. See figure 2-2.

Air-to-Close Fisher Type GX Actuators

WARNING

Refer to the Installation WARNING at the beginning of this section.

The DVC2000 digital valve controller mounts directly on the Fisher Type GX actuator without the need for a mounting bracket.

1. Loosely attach the feedback pieces and magnet assembly to the valve stem connector. Do not tighten the fasteners because fine adjustment is required.

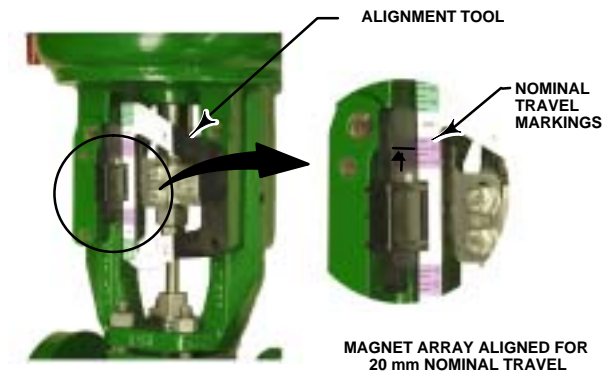

Figure 2-9. Air-to-Close Fisher GX Magnet Array Alignment

CAUTION

Do not install a magnet array that is shorter than the physical travel of the actuator. Loss of control will result from the magnet array moving outside the range of the index mark in the feedback slot of the DVC2000 housing.

2. Using the alignment tool (supplied with the mounting kit), position the feedback array inside the retaining slot.

3. Find the mark on the upper travel scale that corresponds with the actual valve travel. See figure 2-9.

4. Vertically align the magnet array such that the nominal valve travel is lined up with the upper extreme of the valid travel range on the feedback array.

5. Tighten the bolts and remove the alignment tool.

6. Remove the digital valve controller's cover.

7. Using a 6 mm hex wrench, attach the digital valve controller to the GX actuator mounting pad.



Note

The O-ring and G1/4 or 1/4NPT plugs (supplied in the mounting kit) are not used with this actuator construction.

8. Check for clearance between the magnet assembly and the DVC2000 feedback slot. The magnet assembly should be positioned such that the index mark on the pole pieces (back of the positioner housing) is between the valid range on the magnet assembly throughout the range of travel. See figure 2-2.

9. Install tubing between the actuator casing and the pneumatic positioner output connection that has the arrow pointing away from the opening. See figure 2-7.



Note

When field converting a GX actuator from fail-open to fail-closed (or vice-versa), you will need to change the plugs for the pneumatic passages in the DVC2000 housing.

- To convert to fail-closed, remove the R1/8 pneumatic plug on the back of the DVC2000 housing and install an O-ring. Plug the external pneumatic output with a 1/4NPT or G1/4 plug (depending on the housing version). Refer to figure 2-10.

- To convert to fail-open, remove the external pneumatic plug (1/4NPT or G1/4 plug depending on the housing version). Install an R1/8 plug on the back of the DVC2000 housing. Install tubing between the pneumatic output connection of the DVC2000 to the pneumatic output connection of the DVC2000 to the pneumatic port on top of the actuator casing.

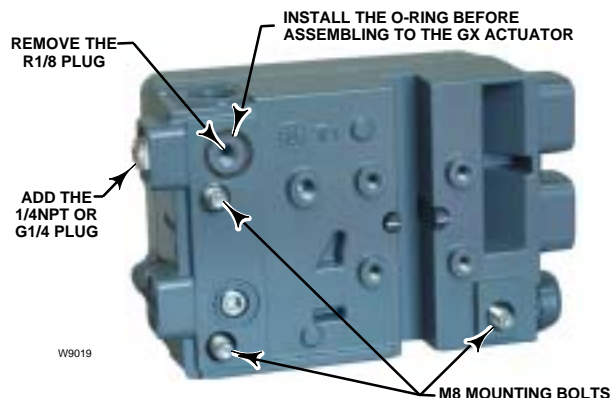

2

Figure 2-10. Modifications for Fisher GX Actuator – Air-to-Open Construction Only



Figure 2-11. For Rotary Actuators (with Typical Mounting Bracket Shown)

Guidelines for Mounting on Quarter-Turn (Rotary) Actuators

WARNING

Refer to the Installation WARNING at the beginning of this section.

The DVC2000 digital valve controller can be mounted to any quarter-turn (rotary) actuator, as well as those that comply with the NAMUR guidelines. A mounting bracket and associated hardware are required. Refer to figure 2-11.

1. Attach the magnet assembly to the actuator shaft. At mid-travel, the flats on the magnet assembly must be parallel to the channel on the back of the DVC2000 housing, as shown in figure 2-12.

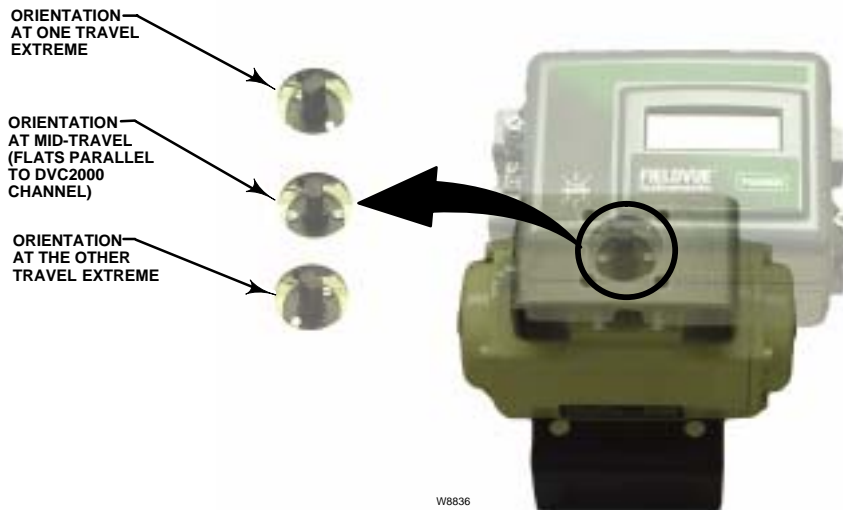

Figure 2-12. Magnetic Assembly Orientation on Quarter-Turn Actuators

2. Install the mounting bracket on the actuator.
3. Attach the digital valve controller to the mounting bracket using the 4 mounting bolts, as shown in figure 2-13.
4. Check for clearance between the magnet assembly and the positioner feedback slot.
5. Install tubing between the actuator casing and the pneumatic positioner output connection that has the arrow pointing away from the opening. See figure 2-7.

Electrical and Pneumatic Connections

WARNING

Refer to the Installation WARNING at the beginning of this section.

The electrical and pneumatic connections on the digital valve controller are available with the following combinations:

- 1/4-inch NPT supply and output with 1/2-inch NPT conduit connections
- G1/4 supply and output with M20 conduit connections

Supply Connections

WARNING

Severe personal injury or property damage may occur from process instability if the instrument air supply is not clean, dry and oil-free. While use and regular maintenance of a filter that removes particles larger than 40 microns in diameter will suffice in most applications, check with a Fisher field office and Industry Instrument air quality standards for use with corrosive air or if you are unsure about the proper amount or method of air filtration or filter maintenance.

Supply pressure must be clean, dry air or noncorrosive and nonflammable gas that meets the requirements of ANSI/ISA Standard 7.0.01.

A Fisher Type 67CFR filter regulator, or equivalent, may be used to filter and regulate supply air. If pressure regulation is not required, a Fisher Type P594 filter may be used.

Connect the nearest suitable supply source to the connection with the arrow pointing towards the opening (see figure 2-7).

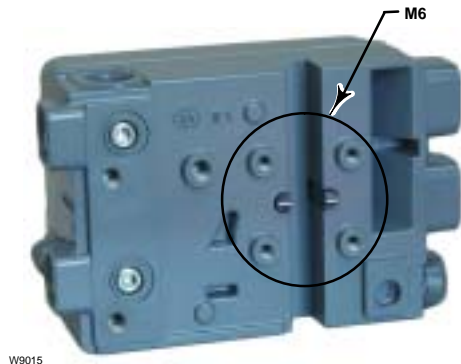

Figure 2-13. DVC2000 Rotary Mounting Holes

Electrical Connections

The digital valve controller is normally powered by a control system output card. The use of shielded cable will ensure proper operation in electrically noisy environments. Wire size requirements are 14 AWG maximum, 26 AWG minimum.

Be sure to follow the appropriate I.S. circuit guidelines when installing field wiring to the loop terminals as well as the limit switch and transmitter terminals.

Wire the digital valve controller as follows:

1. Remove the main instrument cover.
2. Route the field wiring into the terminal box through the conduit connection. When applicable, install conduit using local and national electrical codes that apply to the application.
3. Connect the control system output card positive wire “current output” to the +11 terminal. Connect the control system output card negative (or return) wire “current output” to the -12 terminal.
4. Two ground terminals are available for connecting a safety ground, earth ground, or drain wire. These ground terminals are electrically identical. Make connections to these terminals following national and local codes and plant standards.
5. Replace the cover if the local interface is not being used for configuration or calibration.

Options Boards

All three options circuits (transmitter, switch 1 and switch 2) control current from an external power source similar to the operation of a 2-wire transmitter.

Limit Switches

On units that are supplied with integral limit switches, additional terminals provide the field wiring connection point. The limit switches are isolated from each other and from the digital valve controller’s primary feedback. If only one switch is to be used, you must use channel 1. Although electrically isolated per Intrinsically Safe requirements, channel 2 derives its power from channel 1. Therefore channel 2 cannot be used alone.

Wire the limit switches as follows:

1. Remove the main instrument cover.
2. Route the field wiring into the terminal box through the conduit connection. When applicable, install conduit using local and national electrical codes that apply to the application.
3. Connect the control system input card positive wire “switch input” to the +41 terminal. Connect the control system input card negative wire “switch input” to the -42 terminal. Refer to figure 2-14.
4. If a second switch is to be used, connect the control system input card positive wire “switch input” to the +51 terminal. Connect the control system input card negative wire “switch input” to the -52 terminal.
5. Proceed to the Basic Setup section to configure the switch action.
6. Replace the cover if the local interface is not being used for configuration or calibration.

Position Transmitter

On units that are supplied with an integral valve position transmitter, additional terminals provide the field wiring connection point. The position transmitter circuit in the DVC2000 derives its operating power from the 4–20 mA control system input in the same manner as a 2-wire transmitter. In addition, the transmitter function gets position information (through an opto-isolator) from the digital valve controller so the 4–20 mA position control loop must also be powered in order for the position transmitter to provide an output representing the valve position.



Note

In an Intrinsically Safe installation with the options in use, the wire pairs must be shielded. Additionally, to prevent cross-wiring, the individual wires must not be exposed beyond the terminal barrier walls.

DVC2000 Series

2

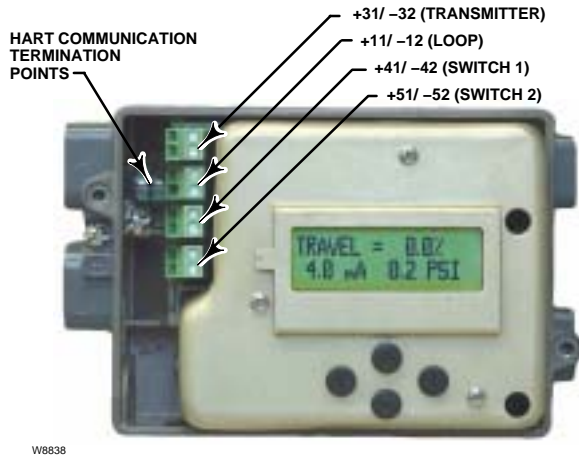

W8838

Figure 2-14. Loop, Transmitter, and Limit Switch Terminals

Wire the position transmitter as follows:

1. Remove the main instrument cover.
2. Route the field wiring into the terminal box through the conduit connection. When applicable, install conduit using local and national electrical codes that apply to the application.
3. Connect the control system input card positive wire “current input” to the +31 terminal. Connect the control

system input card negative wire “current input” to the -32 terminal. Refer to figure 2-14.

4. Replace the cover if the local interface is not being used for configuration or calibration.

Vent

By design, the instrument exhausts supply air into the area under the cover. The vent should be left open to prevent pressure buildup under the cover and to drain any moisture that may accumulate in the housing. The control valve assembly should be installed such that the primary vent provides gravitational draining.

If a remote vent is required, the vent line must be as short as possible with a minimum number of bends and elbows.

Communications Connections

A HART communicating device, such as a Model 375 Field Communicator or a personal computer running AMS ValveLink Software communicating through a HART modem, interfaces with the DVC2000 Series digital valve controller. You can connect at any point on the 4–20 mA loop. Alternatively, convenient termination points are located on the termination board (figure 2-14). The instrument must be powered before digital communication will commence.

Section 3 Basic Setup and Calibration with Local Interface

Status Information	3-2
Basic Setup	3-3
Selecting the Language	3-3
Quick Setup	3-4
Travel Calibration	3-5
Tuning	3-6
Detailed Setup	3-7
Analog Input Calibration	3-9
Position Transmitter Calibration	3-10
Local Control	3-11
Diagnostic Messages, Codes & Details	3-12
SWITCH 1 ???	
SWITCH 2 ???	
Shutdown Activated	
Travel Deviation	
Replace Main Board	
Check Mounting	
Check Supply	
Check I/P Converter	
Device Locked by HART®	

DVC2000 Series

The local operator interface is available on all DVC2000 Series digital valve controllers. The interface consists of a liquid crystal display, four pushbuttons, and a switch for position transmitter configuration. There are seven languages supported, namely English, French, German, Italian, Spanish, Chinese and Japanese. To configure the language, follow the procedure outlined in the Basic Setup section. The instrument must be powered with at least 8.5 volts and 3.5 mA to operate the local interface. Certain procedures require up to 20 mA of current.

3

CAUTION

When accessing the terminals or pushbuttons, proper means of electrostatic discharge protection is required. Failure to provide appropriate protection can cause the valve to move, resulting in valve/actuator instability.

Status Information

The first (home) screen on the LCD that is displayed after applying power to the instrument contains basic

status information. On an instrument that is calibrated and operating properly, the flow chart in figure 3-1 shows the available information by pressing the right (▶) arrow key.

TRAVEL=##.##%—Current valve travel in percent of calibrated travel.

##.# MA—Current input signal applied to the instrument in mA.

##.## BAR—Current pressure output to the actuator in the configured units (BAR, PSI or MPA).

SWITCH1—Current status of the optional limit switch wired to terminals +41 and -42.

SWITCH2—Current status of the optional limit switch wired to terminals +51 and -52.

FW#—Version of firmware running in the device.

HW#—Version of electronics hardware installed. The first number (# : #) represents the main board, the second number (# : #) represents the secondary electronics.

TUNING = X—Current tuning set parameters configured in the device.

PROTECTION—Indicates whether the local interface is protected or not. With protection ON, the instrument can not be configured or calibrated with the local pushbuttons.

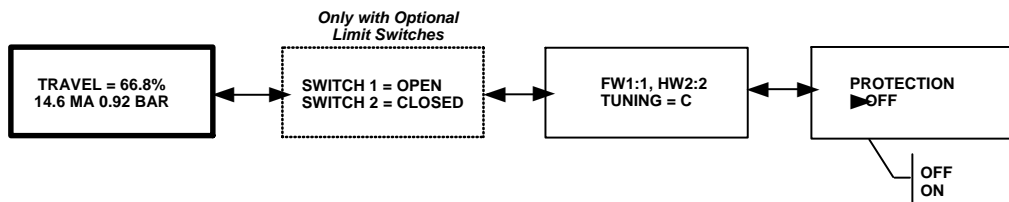

Figure 3-1. Home Screen on the LCD

Basic Setup and Calibration

Basic Setup

WARNING

Changes to the instrument setup may cause changes in the output pressure or valve travel. Depending on the application, these changes may upset process variables, which may result in personal injury or property damage.

When the DVC2000 Series digital valve controller is ordered as part of a control valve assembly, the factory mounts the digital valve controller and sets up the instrument as specified on the order. When mounting to a valve in the field, the instrument needs to be setup to match the instrument to the valve and actuator.

Before beginning basic setup, be sure the instrument is correctly mounted and powered electrically and pneumatically, as described in the Installation section, Section 2.

Selecting the Language

The instrument can be configured to display any of seven different languages including English, French, German, Italian, Spanish, Chinese and Japanese (see figure 3-2). To access the language selection screen, press the four arrow keys simultaneously for three (3) seconds.

Use the UP or DOWN (▲ or ▼) arrow keys to select the appropriate language. Press the RIGHT (▶) arrow key to confirm your selection.

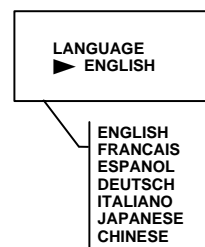

Figure 3-2. Accessing the Language Screen

DVC2000 Series

Quick Setup

When installing the DVC2000 Series digital valve controller on an actuator for the first time, the quick setup procedure will calibrate and tune the instrument automatically. Table 3-1 lists the values that are preconfigured at the factory.

Table 3-1. DVC2000 Factory Default Settings Accessible from the Local Interface

Setup Parameter	Default Setting
Zero Control Signal	Valve Closed
Pressure Units	BAR or PSIG
Input Range Low	4 mA
Input Range High	20 mA
Characteristic	Linear
Transmitter (optional feature)	4 mA = Valve Closed
Switch 1 Trip Point (optional feature)	90%
Switch 1 Closed (optional feature)	Disabled
Switch 2 Trip Point (optional feature)	10%
Switch 2 Closed (optional feature)	Disabled

WARNING

3

During calibration the valve will move full stroke. Changes to the tuning set may also cause the valve/actuator assembly to stroke. To avoid personal injury and property damage caused by the release of pressure or process fluid, provide some temporary means of control for the process.

Refer to the DETAILED SETUP procedure for further explanation of the parameters.

To access the QUICK SETUP routine from the home screen, press the DOWN (▼) arrow key and then the RIGHT (▶) arrow key. A warning will advise you that this procedure will cause the valve to move. Another RIGHT (▶) button press will begin the calibration process. Pressing the LEFT (◀) arrow key will bring you back to the main menu.

This procedure will automatically calibrate the instrument and apply tuning parameters specifically fit for the size of the actuator.

To abort the procedure at any time, press the RIGHT (▶) and LEFT (◀) arrow keys together for 3 seconds.

When the procedure is complete, press the RIGHT (▶) arrow key to return to the status screen. If the RIGHT (▶) button is not pressed within 30 seconds, the device will revert back to the status screen automatically.



Note

If optional limits switches are being used, power must be applied to the switch circuits throughout the quick setup routine.

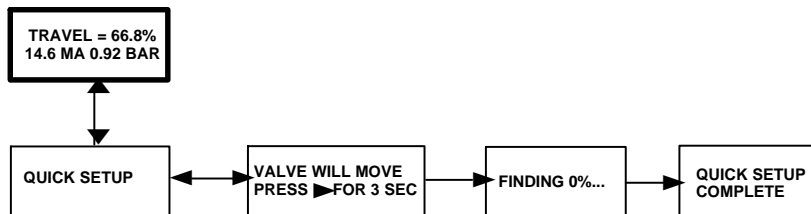

Figure 3-3. Quick Setup

Basic Setup and Calibration

Travel Calibration

WARNING

During calibration the valve will move full stroke. To avoid personal injury and property damage caused by the release of pressure or process fluid, provide some temporary means of control for the process.

values, the TRAVEL CALIBRATION routine is available. To access this procedure from the home screen, press the DOWN (▼) arrow key two times and then the RIGHT (▶) arrow key once. From there follow the prompts as illustrated in figure 3-4.



Note

If the valve is manually calibrated to travel less than the physical travel stops allow, manual tuning (page 3-6) may be required to optimize the valve response.

3



Note

If optional limits switches are being used, power must be applied to the switch circuits throughout the automatic or manual calibration routine.

Automatic calibration will provide status information as the procedure is running. Manual calibration will require you to first adjust the input current to move the valve and then to press the RIGHT (▶) arrow key. After manual calibration is complete, you will have the choice to save the calibration or exit the procedure without saving. If you exit without saving, the last saved calibration data will be restored.

To manually calibrate the instrument or automatically calibrate the instrument without changing the tuning

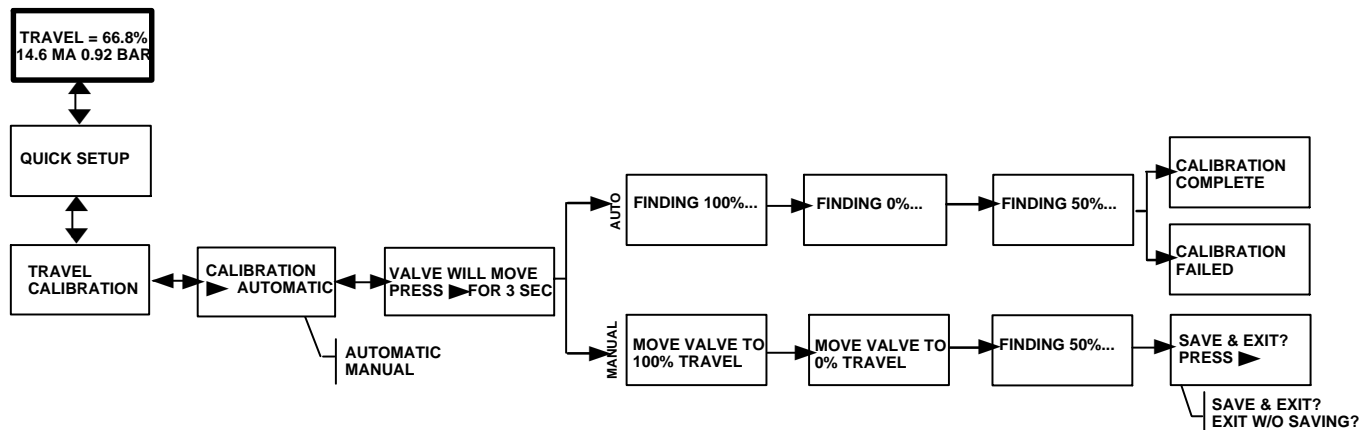

Figure 3-4. Travel Calibration

DVC2000 Series

Tuning

WARNING

Changes to the tuning set may cause the valve/actuator assembly to stroke. To avoid personal injury and property damage caused by the release of pressure or process fluid, provide some temporary means of control for the process.

3

To manually tune the instrument or automatically tune the instrument without changing the calibration values, the TUNING routine is available. To access this procedure from the home screen, press the DOWN (▼) arrow key three times and then the RIGHT (▶) arrow key once.

From there follow the prompts as illustrated in figure 3-5 below.

Automatic tuning will provide status information as the procedure is running. Manual tuning will require you to input values. This procedure is only recommended when the automatic tuning procedure results in failure.

A typical starting point for most small actuators is “C”. Using the UP (▲) and DOWN (▼) arrow keys will apply the values immediately. You can then change the input current to observe the response. When you are satisfied with the response, press the RIGHT (▶) arrow key to fine tune the instrument. The UP (▲) and DOWN (▼) arrow keys will apply more or less damping to fine tune the overshoot after a step input change.

After manual tuning is complete, you will have the choice to save the tuning data or exit the procedure without saving. If you exit without saving, the last saved tuning data will be restored.

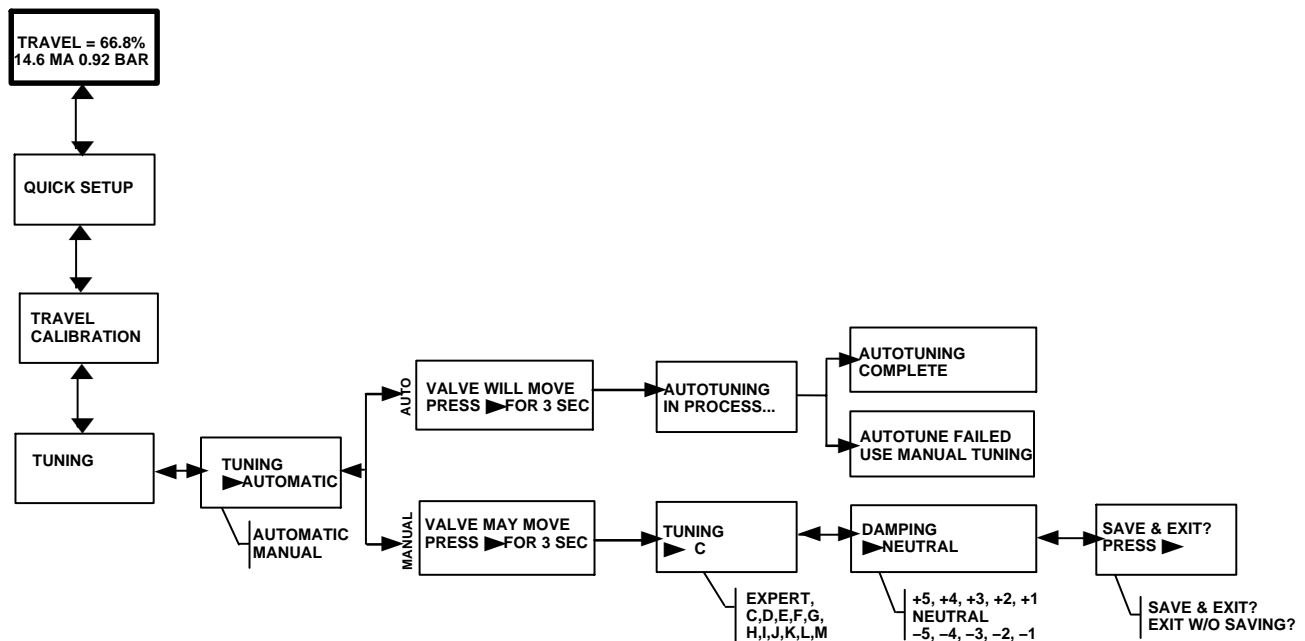

Figure 3-5. Tuning

Basic Setup and Calibration

Detailed Setup

If the factory default configuration values need to be changed, the DETAILED SETUP procedure provides access. See figure 3-6 for the flowchart showing the sequence of screens. To access this procedure from the home screen, press the DOWN (▼) arrow key four times. The RIGHT (▶) arrow key brings you into the configuration items. Once you are in a particular configuration item, use the UP (▲) and DOWN (▼) arrow keys to select the appropriate choice.

To exit this procedure, press the RIGHT (▶) arrow key and view the remaining configuration items until you reach the exit screen. If you exit without saving, the last saved configuration data will be restored.

Below is an explanation of the configuration items.

Zero Control Signal—Identifies whether the valve is fully OPEN or fully CLOSED when the input is 0%. If you are unsure how to set this parameter, disconnect the current source to the instrument. The resulting valve travel is the Zero Control Signal. This corresponds to setting the output pressure to zero.

Pressure Units—Defines the pressure units in either PSI, BAR, or KPA.

Input Range Low—This will correspond to 0% travel if the Zero Control Signal is configured as closed. If the Zero Control Signal is configured as open, this will correspond to 100% travel.

Input Range High—This will correspond to 100% travel if the Zero Control Signal is configured as closed. If the Zero Control Signal is configured as open, this will correspond to 0% travel.

Characteristic—Defines the relationship between the travel target and the ranged set point. Ranged set point is the input to the characterization function. If the Zero Control Signal is closed, then a set point of 0% corresponds to a ranged input of 0%. If the Zero Control Signal is open, a set point of 0% corresponds to a ranged input of 100%. Travel target is the output from the characterization function.

3



Note

Travel cutoffs are enabled by default on all units.

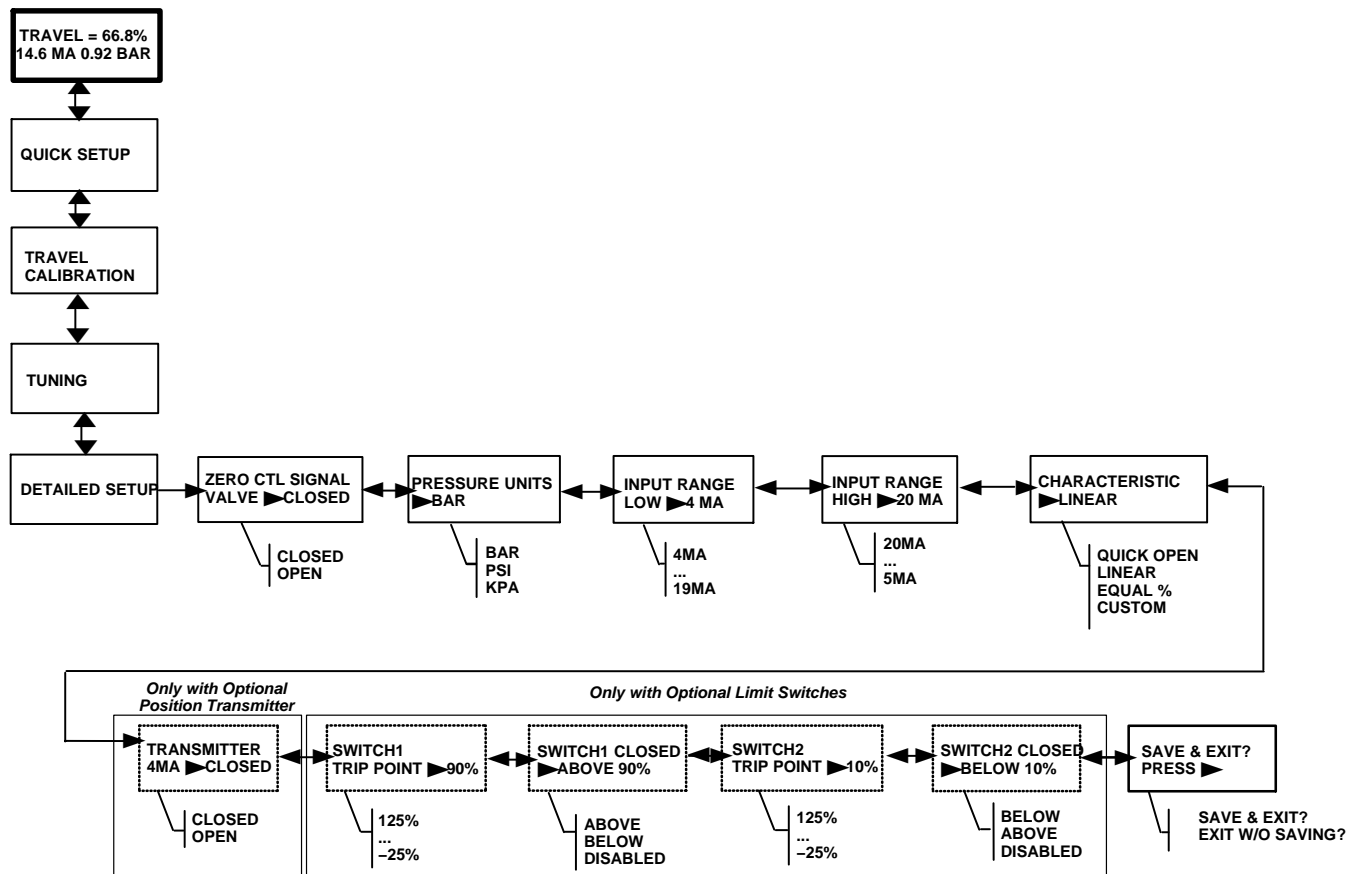

Figure 3-6. Detailed Setup Flow Chart

DVC2000 Series

The factory default characteristic is LINEAR. You can also use a QUICK OPEN, EQUAL %, or CUSTOM function. However, the custom function is initially configured linear, unless you use a HART based host to reconfigure the custom points. Custom configuration can be selected, but the curve can not be modified with the local interface.

Transmitter—This configures the relationship between the valve travel and the position transmitter output signal. If you select CLOSED, the transmitter will send 4 mA when the valve is closed. If you select OPEN, the transmitter will send 4 mA when the valve is open.

3

A switch is located on the options board to configure the transmitter fail signal (high+ or low-). High+ will result in a current output of > 22.5 mA upon transmitter failure. Low- will result in a current output of < 3.6 mA. Refer to figure 3-7 for location and configuration.

Switch #1 Trip Point—Defines the threshold for the limit switch wired to terminals +41 and -42 in percent of calibrated travel.

Switch #1 Closed—Configures the action of the limit switch wired to terminals +41 and -42. Selecting ABOVE configures the switch to be closed when the travel is above the trip point. Selecting BELOW configures the switch to be closed when the travel is below the trip point. Selecting DISABLED removes the icons and status from the display.

Switch #2 Trip Point—Defines the threshold for the limit switch wired to terminals +51 and -52 in percent of calibrated travel.

Switch #2 Closed—Configures the action of the limit switch wired to terminals +51 and -52. Selecting ABOVE

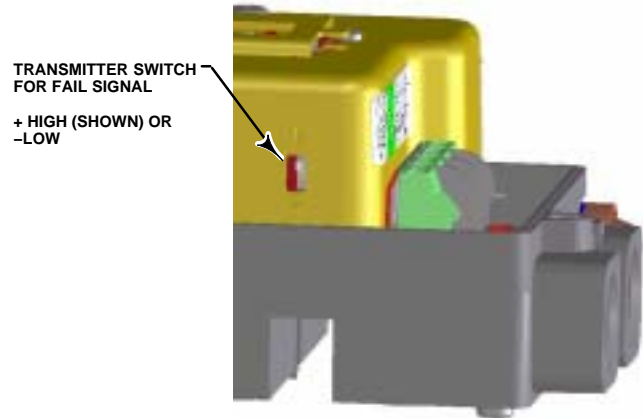

Figure 3-7. XMTR Switch

configures the switch to be closed when the travel is above the trip point. Selecting BELOW configures the switch to be closed when the travel is below the trip point. Selecting DISABLED removes the icons and status from the display.



Note

Switch #2 is only operational if power is applied to switch #1 also. Switch #2 cannot be used alone.

Basic Setup and Calibration

Analog Input Calibration

WARNING

During calibration you will be asked to move the valve full stroke. To avoid personal injury and property damage caused by the release of pressure or process fluid, provide some temporary means of control for the process.

The DVC2000 Series digital valve controller is shipped from the factory with the analog input already calibrated. You do not normally need to perform this procedure. However, if you suspect that this needs

adjustment, follow the procedure below, and refer to figure 3-8.

Connect a variable current source to the instrument +11 and -12 terminals. From the home screen, press the DOWN (▼) arrow key five times and then press the RIGHT (▶) arrow key. Acknowledge the warning if you are sure that you want to proceed.

1. Adjust the variable current source to 4 mA.
2. Press the RIGHT (▶) arrow key
3. Adjust the variable current source to 20 mA.
4. Press the RIGHT (▶) arrow key.

If you want to keep this calibration, select SAVE AND EXIT. If you exit without saving, the last saved configuration data will be restored.

3

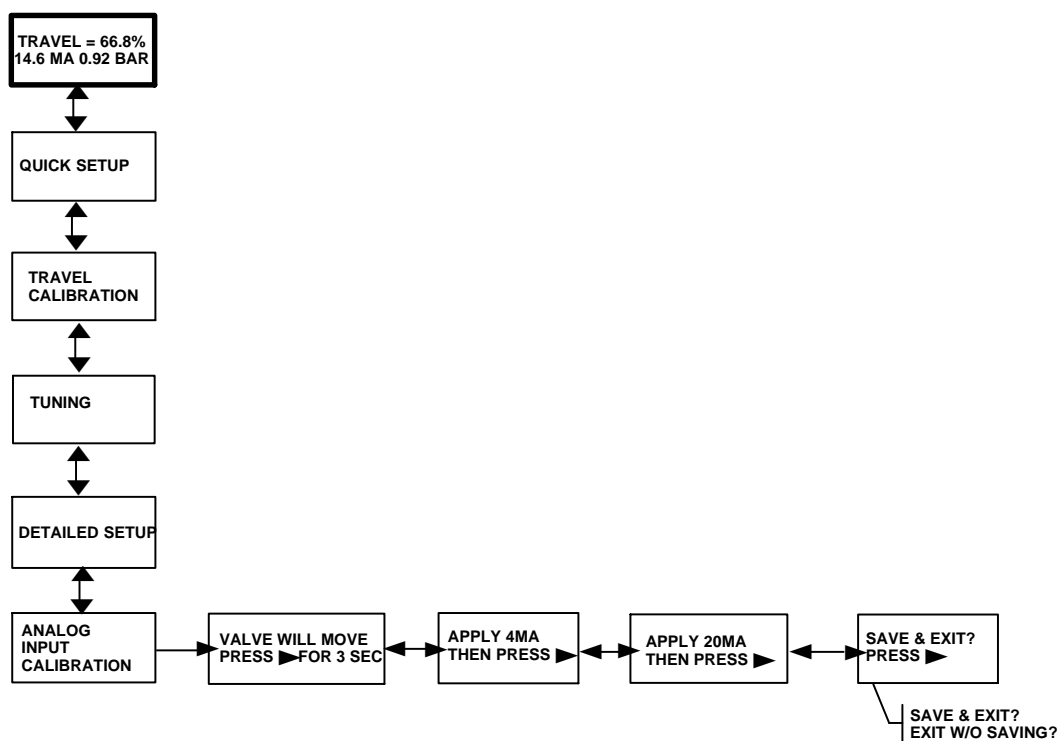

Figure 3-8. Analog Input Calibration

DVC2000 Series

Position Transmitter Calibration



Note

This procedure will not move the control valve. The instrument will simulate an output for calibration purposes only.

3

This procedure is only available on units that have the optional position transmitter hardware installed. The DVC2000 Series digital valve controller is shipped from the factory with the position transmitter already calibrated. You do not normally need to perform this procedure. However, if you suspect that this needs

adjustment, follow the procedure below and refer to figure 3-9.

Connect a current meter in series with the transmitter output terminals (+31 & -32) and a voltage source (such as the DCS analog input channel). From the home screen, press the DOWN (▼) arrow key six times and then press the RIGHT (▶) arrow key.

1. Use the UP (▲) and DOWN (▼) arrow keys to manipulate the output current read by the current meter. When 4 mA is read by the meter, press the RIGHT (▶) arrow key.

2. Again, use the UP (▲) and DOWN (▼) arrow keys to manipulate the output current read by the current meter. When 20 mA is read by the meter, press the RIGHT (▶) arrow key.

If you want to keep this calibration, select SAVE AND EXIT. If you exit without saving, the last saved configuration data will be restored.

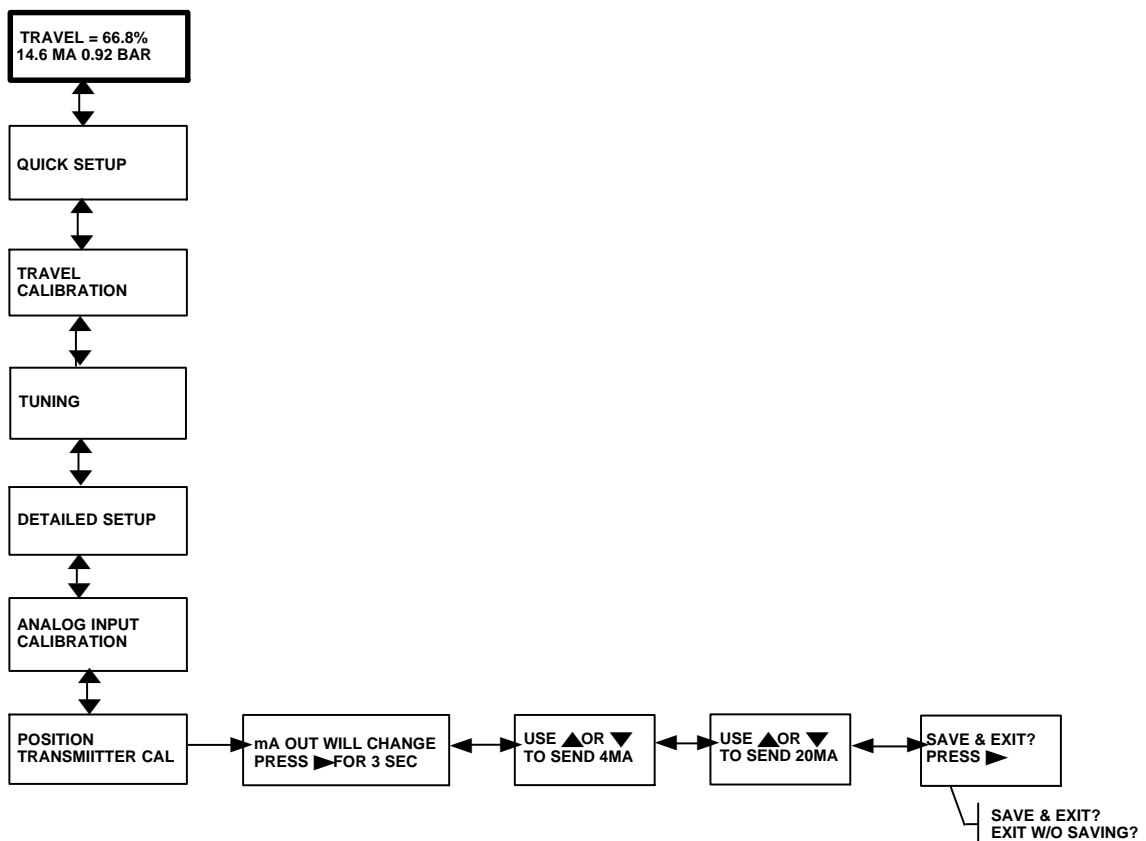

Figure 3-9. Position Transmitter Calibration

Basic Setup and Calibration

Local Control

This procedure allows the user to manually control the position of the valve (see figure 3-10). To enter this procedure from the home screen, press the DOWN (▼) arrow key seven times and then press the RIGHT (▶) arrow key.

If you select ANALOG, you will return to the home screen and the digital valve controller will respond to the loop current. If you select MANUAL, you will move to the screen that shows the travel setpoint and the actual valve travel. The UP (▲) and DOWN (▼) arrow keys will allow you to change the setpoint and therefore move the valve manually. To exit the manual mode, use the LEFT (◀) arrow key to return to the choice list. Select ANALOG.



Note

When placing the instrument back into ANALOG, the valve will step back to the position commanded by the input current.

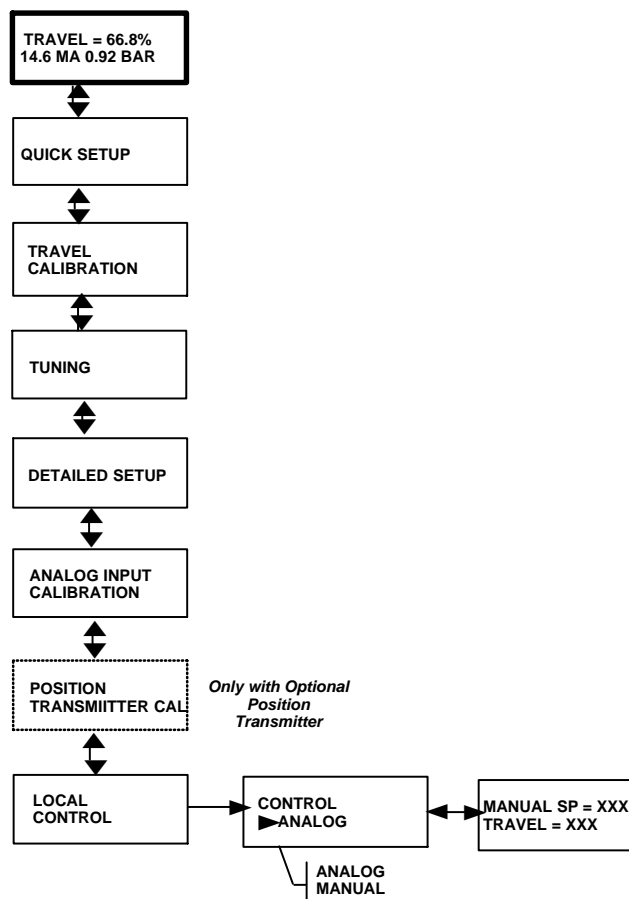



Figure 3-10. Local Control

Diagnostic Messages, Codes and Details

The DVC2000 series digital valve controller is constantly diagnosing itself for abnormal conditions while powered-up. The following messages will appear on the local user interface if a fault condition exists (identified on the default screen by the alert symbol ).

SWITCH 1 ???

3

SWITCH 2 ???—The alert symbol in conjunction with the above text indicates that limit switch circuit 1 is not powered, or at least one of the switches is enabled. In order for either of the switches to work, switch circuit 1 must be powered. Switch 2 cannot be used alone. To eliminate the alert symbol, you can either apply 5 to 30 VDC to switch circuit 1 or disable both switches (refer to the Installation section).

Once switch circuit 1 is powered properly, question marks (???) will indicate that the corresponding switch is disabled.

Shutdown Activated— This screen appears if the positioner has shut down and no air is being delivered to the actuator. Therefore, the valve is at its fail-safe position. An example of a source of this error is corrupt firmware code upon start-up. The factory default setting for this error is disabled. Therefore, this alert will only be enabled by actively configuring it with a HART based host (eg. Field Communicator, AMS ValveLink Software).

Travel Deviation— This error message indicates that there is a difference between the input signal (after characterization) and the actuator travel reading from the position feedback element. The default setting is 7% for 5 seconds. These settings can be configured

through a HART communicating host on any HC tier or higher. Possible sources of this error are insufficient air supply or excessive valve friction.

Replace Main Board— A problem with the electronics has been detected. Sources of this error may include hardware or firmware problems. If this error is detected, the instrument may be operational, but performance will be degraded.

Check Mounting— The valve position feedback reading is valid, but it is outside the operating range. Sources of this error include loose or bent mounting brackets or a misaligned magnet array. This error does not identify faulty components, but rather faulty installation or alignment. This alert is also called a Travel Sensor Failure.

Check Supply— The valve is not able to reach its target position due to insufficient supply pressure. This error will most likely occur in conjunction with the Travel Deviation error.

Check I/P Converter— A problem relating to the I/P converter has been detected. Sources of this error include:

- Electronics problems indicated by the drive current read back being out of range
- Low supply pressure indicated by an active drive signal alert
- A stuck valve resulting in integrator wind-up.

Device Locked by HART— Another HART host (e.g. AMS ValveLink Software, AMS Suite™: Intelligent Device Manager, or the 375 Field Communicator) is communicating with the DVC2000. Typically this means that the instrument is “out of service”.

Section 4 Advanced Setup and Calibration via HART Communication

Detailed Setup	4-3
Setting Modes	4-3
Instrument Mode	4-3
Control Mode	4-4
Restart Control Mode	4-4
Burst Mode	4-4
Restarting the Instrument	4-4
Protection	4-4
General Information	4-6
HART Tag	
Message	
Descriptor	
Date	
Valve Serial Number	
Instrument Serial Number	
Polling Address	
Measured Variable Units and Ranges	4-6
Analog Input Units	
Analog Input Range High and Low	
Pressure Units	
Temperature Units	
Actuator and Valve Information	4-6
Maximum Supply Pressure	
Actuator Style	
Valve Style	
Zero Control Signal	
Setting Response	4-7
Tuning Set	
Input Characteristic	
Set Point Filter Time	
Minimum Opening and Closing Time	
Setting Travel Limits and Cutoffs	4-8
Travel Limit High	
Travel Limit Low	
Travel Cutoff High	
Travel Cutoff Low	
Setting Alerts	4-9

DVC2000 Series

Self-Test Failures for Instrument Shutdown	4-9
Tuning	4-10
Automatic	4-10
Manual	4-10
Calibration	4-10
Automatic Travel	4-10
Manual Travel	4-10
Analog Calibration Adjust	4-10
Digital Calibration Adjust	4-11
Analog Input Calibration	4-11
Pressure Sensor	4-12
Output Pressure Sensor	4-12

Advanced Setup and Calibration

Detailed Setup

The DVC2000 Series digital valve controller has the capability to communicate via the HART protocol. This section describes the advanced features that can be accessed with the Model 375 Field communicator.

Setting Modes



To view or change the mode, select the *Setup & Diag* Menu, *Detailed Setup*, and *Mode*. Follow the prompts on the Field Communicator display to view or change information in the following fields: *Instrument Mode*, *Control Mode*, *Restart Ctrl Mode* (Restart Control Mode), *Restart*, and *Burst*.

Instrument Mode



You can change the instrument mode by selecting *Instrument Mode* from the *Mode* menu, or press the Hot Key and select *Instrument Mode*.

Instrument Mode allows you to either take the instrument Out Of Service or place it In Service. Taking the instrument Out Of Service allows you to perform instrument calibration and also allows you to change setup variables that affect control, provided the calibration/configuration protection is properly set. See Setting Protection.



Note

Some changes that require the instrument to be taken Out Of Service will not take effect until the instrument is placed back In Service or the instrument is restarted.

Table 4-1. Factory Default Detailed Setup Parameters

Setup Parameter	Default Setting ⁽¹⁾
Control Mode	Analog
Restart Control Mode	Resume Last
Burst Mode Enabled	No
Burst Mode Command	3
HART Tag	As specified on order
Message	Blank
Descriptor	Blank
Date	Factory Calibration Date
Valve Serial Number	Blank
Polling Address	0
Max Supply Pressure	100 ⁽²⁾
Zero Control Signal	Open ⁽²⁾
Analog Input Units	mA
Analog In Range High	20 mA
Analog In Range Low	4.0 mA
Travel Range High	100%
Travel Range Low	0%
Pressure Units	PSI ⁽²⁾
Temperature Units	F
Input Characteristic	Linear
Set Point Filter Time	Filter Off
Travel Limit High	125%
Travel Limit Low	-25%
Travel Cutoff High	99.5%
Travel Cutoff Low	0.5%
Minimum Opening Time	0 secs
Minimum Closing Time	0 secs
Integral Gain	1 repeat/minute
Integral Deadband	0.5%
Travel Hi/Lo Alert Enabled	No
Travel Hi Hi/Lo Lo Alert Enabled	No
Travel Alert High Point	125%
Travel Alert Low Point	-25%
Travel Alert High-High Point	125%
Travel Alert Low-Low Point	-25%
Travel Alert Deadband	1%
Travel Deviation Alert Enable	Yes
Travel Deviation Alert Point	7%
Travel Deviation Time	5 secs
Cycle Counter Alert Enable	No
Cycle Counter Alert Point	2,147,483,646
Cycle Counter Deadband	3%
Cycle Counter	0
Travel Accumulator Alert Enable	No
Travel Accumulator Alert Point	2,147,483,646%
Travel Accumulator Deadband	3%
Travel Accumulator	0
Drive Alert Enable	No
Flash ROM Fail	No
No Free Time	No
Ref Voltage Fail	No
Drive Current Fail	No
Critical NVM Fail	No
Temperature Sensor Fail	No
Pressure Sensor Fail	No
Travel Sensor Fail	No

1. The settings listed are for standard factory configuration. DVC2000 Series instruments can also be ordered with custom configuration settings. For the default custom settings, refer to the order requisition.
2. If the instrument is shipped mounted on an actuator, these values depend upon the actuator on which the instrument is mounted.

DVC2000 Series

Control Mode

You can change the control mode by selecting *Control Mode* from the *Mode* menu, or press the Hot Key and select *Control Mode*.

Control Mode lets you define where the instrument reads its set point. Follow the prompts on the Field Communicator display to choose one of the following control modes: Analog or Digital.

Choose Analog if the instrument is to receive its set point over the 4–20 mA loop. Normally the instrument control mode is Analog.

Choose Digital if the instrument is to receive its set point digitally, via the HART communications link.

A third mode, Test, is also displayed. Normally the instrument should not be in the Test mode. The Field Communicator automatically switches to this mode whenever it needs to stroke the valve, for example during calibration or stroke valve. However, if you abort from a procedure where the instrument is in the Test mode, it may remain in this mode. To take the instrument out of the Test mode, select *Control Mode* then select either Analog or Digital.

Restart Control Mode

Restart Control Mode (*Restart Ctrl Mode*) lets you choose which operating mode you want the instrument to be in after a restart. Follow the prompts on the Field Communicator display to define the restart control mode as Resume Last, Analog, or Digital.

Burst Mode

Enabling burst mode provides continuous communication from the digital valve controller. Burst mode applies only to the transmission of burst mode data (analog input, travel target, pressure, and travel) and does not affect the way other data is accessed.

Access to information in the instrument is normally obtained through the poll/response of HART communication. The Model 375 Field Communicator or the control system may request any of the information that is normally available, even while the instrument is in burst mode. Between each burst mode transmission sent by the instrument, a short pause allows the Field Communicator or control system to initiate a request. The instrument receives the request, processes the response message, and then continues “bursting” the burst mode data.

There are four burst mode commands. Command 3 is recommended for use with the Rosemount® Model 333 HART Tri-Loop® HART-to-analog signal converter. The other three are not used at this time.

Command 3 provides the following variables:

- Primary variable—analog input in % or mA,
- Secondary variable—travel target (valve set point) in % of ranged travel,
- Tertiary variable—output pressure in psig, bar, or kPa.
- Quaternary variable—travel in % of ranged travel.

To enable burst mode, from the *Online* menu, select *Setup & Diag, Detailed Setup, Mode, Burst, and Burst Enable*. To send a burst mode command, select *Setup & Diag, Detailed Setup, Mode, Burst, and Burst Command*. Burst mode must be enabled before you can change the burst mode command.

Restarting the Instrument

Restart resets the instrument in the same manner as when power to the instrument is interrupted. When Restart is issued, all of the newly entered configuration variables become active. Otherwise, they may not take effect until the instrument is placed In Service.

Setting Protection

Some setup parameters may require changing the protection with the Field Communicator.

Two levels of protection are available:

- *Config & Calib*—Both setup and calibration are protected. Prohibits changing calibration and protected setup parameters.
- *None*—Neither setup nor calibration is protected. Allows changing calibration and setup parameters.

Table 4-2 lists configurable parameters in the instrument and the requirements for modifying these parameters, in terms of instrument mode and protection.

To change an instrument's protection, press the Hot key  on the Field Communicator display window and select *Protection* or select *Protection* from the *Detailed Setup* menu. Select the desired level of protection. Follow the prompts on the Field Communicator display to set the protection level.

Advanced Setup and Calibration

Table 4-2. Conditions for Modifying DVC2000 Series Digital Valve Controller Parameters

Parameters	In Service/ Config Protected	In Service/ Config Unprotected	Out of Service/ Config Protected	Out of Service/ Config Unprotected
Control Mode	---	---	✓	✓
Restart Ctrl Mode	---	---	---	✓
Burst Mode Enable	✓	✓	✓	✓
Burst Mode Command Protection	---	---	---	✓
	✓	✓	✓	✓
HART Tag	---	✓	---	✓
Message	---	✓	---	✓
Descriptor	---	✓	---	✓
Date	---	✓	---	✓
Valve Serial Num	---	✓	---	✓
Inst Serial Num	---	---	---	✓
Polling Address	---	---	---	✓
Max Supply Pressure	---	---	---	✓
Zero Ctrl Signal	---	---	---	✓
Analog In Units	---	---	---	✓
Input Range High	---	---	---	✓
Input Range Low	---	---	---	✓
Pressure Units	---	---	---	✓
Temp Units	✓	✓	✓	✓
Tuning Set	---	✓	---	✓
Prop Gain	---	✓	---	✓
Velocity Gain	---	✓	---	✓
MLFB Gain	---	✓	---	✓
Input Char	---	---	---	✓
Define Custom Char	---	---	---	✓
Set Pt Filter Time	---	---	---	✓
Tvl Limit High	---	---	---	✓
Tvl Limit Low	---	---	---	✓
Tvl Cutoff High	---	---	---	✓
Tvl Cutoff Low	---	---	---	✓
Min Opening Time	---	---	---	✓
Min Closing Time	---	---	---	✓
Integral Gain	---	✓	---	✓
Integral Deadband	---	✓	---	✓
Tvl Hi/Lo Enab	✓	✓	✓	✓
Tvl HH/LL Enab	✓	✓	✓	✓
Tvl Alert Hi Pt	✓	✓	✓	✓
Tvl Alert Lo Pt	✓	✓	✓	✓
Tvl Alert HiHi Pt	✓	✓	✓	✓
Tvl Alert LoLo Pt	✓	✓	✓	✓
Tvl Alrt DB	✓	✓	✓	✓
Tvl Dev Alrt Enab	✓	✓	✓	✓
Tvl Dev Alrt Pt	✓	✓	✓	✓
Tvl Dev Time	✓	✓	✓	✓
Cycl Cnt Alrt Enab	✓	✓	✓	✓
Cycl Count Alrt Pt	✓	✓	✓	✓
Cycl Count DB	✓	✓	✓	✓
Cycl Count	✓	✓	✓	✓
Tvl Acum Alrt Enab	✓	✓	✓	✓
Tvl Acum Alrt Pt	✓	✓	✓	✓
Tvl Acum DB	✓	✓	✓	✓
Tvl Acum	✓	✓	✓	✓
Drive Alrt Enab	✓	✓	✓	✓

✓—indicates parameter may be modified for instrument mode and protection shown.

–Continued–

DVC2000 Series

Table 4-2. Conditions for Modifying DVC2000 Series Digital Valve Controller Parameters (Continued)

Parameters	In Service/ Config Protected	In Service/ Config Unprotected	Out of Service/ Config Protected	Out of Service/ Config Unprotected
Flash ROM Fail	---	---	---	✓
No Free Time	---	---	---	✓
Ref Voltage Fail	---	---	---	✓
Drive Current Fail	---	---	---	✓
Critical NVM Fail	---	---	---	✓
Temp Sensor Fail	---	---	---	✓
Press Sensor Fail	---	---	---	✓
Tvl Sensor Fail	---	---	---	✓

✓—indicates parameter may be modified for instrument mode and protection shown.

General Information

Select *Setup & Diag*, *Detailed Setup*, and *General*. Follow the prompts on the Field Communicator display to enter or view information in the following fields: *HART Tag*, *Message*, *Descriptor*, *Date*, *Valve Serial Num* (Valve Serial Number), *Inst Serial Num* (Instrument Serial Number), and *Polling Address*.

- *HART Tag*—Enter an up to 8 character HART tag for the instrument. The HART tag is the easiest way to distinguish between instruments in a multi-instrument environment. Use the HART tag to label instruments electronically according to the requirements of your application. The tag you assign is automatically displayed when the Field Communicator establishes contact with the digital valve controller at power-up.

- *Message*—Enter any message with up to 32 characters. Message provides the most specific user-defined means for identifying individual instruments in multi-instrument environments.

- *Descriptor*—Enter a descriptor for the application with up to 16 characters. The descriptor provides a longer user-defined electronic label to assist with more specific instrument identification than is available with the HART tag.

- *Date*—Enter a date with the format MM/DD/YY. Date is a user-defined variable that provides a place to save the date of the last revision of configuration or calibration information.

- *Valve Serial Num*—Enter the serial number for the valve in the application with up to 12 characters.

- *Inst Serial Num*—Enter the serial number on the instrument nameplate, up to 12 characters.

- *Polling Address*—If the digital valve controller is used in point-to-point operation, the Polling Address is 0. When several devices are connected in the same loop, such as for split ranging, each device must be assigned a unique polling address. The Polling Address is set to a value between 0 and 15. To

change the polling address the instrument must be Out Of Service.

For the Field Communicator to be able to communicate with a device whose polling address is not 0, it must be configured to automatically search for all or specific connected devices. For information on configuring the Field Communicator for automatic polling, see the Model 375 Field Communicator Basics section, Appendix C.

Measured Variable Units and Ranges

To define the measured variable units and ranges, select *Setup & Diag*, *Detailed Setup*, and *Measured Var*. Follow the prompts on the Field Communicator display to enter or view information in the following fields: *Analog In Units* (Analog Input Units), *Analog In Range Hi* (Analog Input Range High), *Analog In Range Lo* (Analog Input Range Low) *Pressure Units*, and *Temp Units* (Temperature Units).

- *Analog Input Units*—Permits defining the Analog Input Units in mA or percent of 4–20 mA range.

- *Analog In Range Hi*—Permits setting the Input Range High value. Input Range High should correspond to Travel Range High, if the Zero Control Signal is configured as closed. If the Zero Control Signal is configured as open, Input Range High corresponds to Travel Range Low. See figure 4-1.

- *Analog In Range Lo*—Permits setting the Input Range Low value. Input Range Low should correspond to Travel Range Low, if the Zero Control Signal is configured as closed. If the Zero Control Signal is configured as open, Input Range Low corresponds to Travel Range High. See figure 4-1.

- *Pressure Units*—Defines the output and supply pressure units in either psi, bar, or kPa.

- *Temp Units*—Degrees Fahrenheit or Celsius. The temperature measured is from a sensor mounted on the digital valve controller's printed wiring board.

Actuator and Valve Information

Select *Setup & Diag*, *Detailed Setup*, and *Actuator & Valve*. Follow the prompts on the Field Communicator

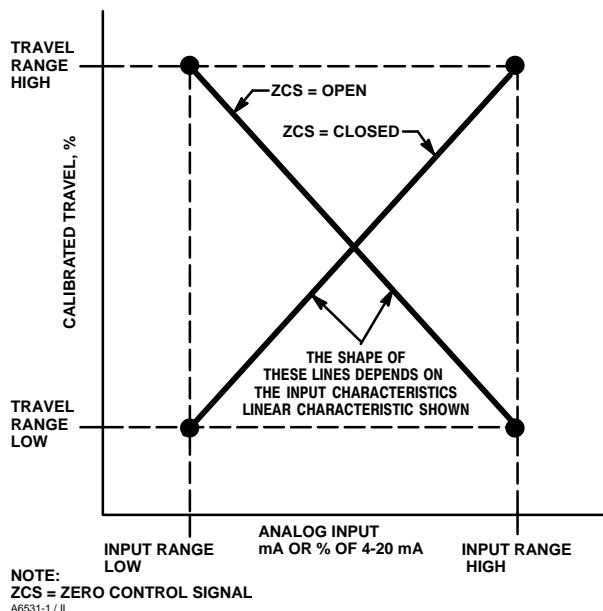

Figure 4-1. Calibrated Travel to Analog Input Relationship

display to enter or view information in the following fields: *Max Supply Press* (Maximum Supply Pressure), *Actuator Style*, *Valve Style*, and *Zero Ctrl Signal* (Zero Control Signal).

- *Max Supply Press*—Enter the maximum supply pressure in psi, bar, or kPa, depending on what was selected for pressure units.
- *Actuator Style*—Enter the actuator style, spring and diaphragm, piston double-acting without spring, piston single-acting with spring, or piston double-acting with spring.
- *Valve Style*—Enter the valve style, rotary or sliding-stem
- *Zero Ctrl Signal*—Identifies whether the valve is fully open or fully closed when the input is 0%. If you are unsure how to set this parameter, disconnect the current source to the instrument. The resulting valve travel is the Zero Control Signal. (With direct acting digital valve controllers, disconnecting the current source is the same as setting the output pressure to zero.)

Setting Response

Select *Setup & Diag*, *Detailed Setup*, and *Response Control*. Follow the prompts on the Field Communicator display to configure the following response control parameters: *Tuning Set*, *Input Char* (Input Characteristic), *Set Pt Filter Time* (Set Point Filter Time).

WARNING

Changes to the tuning set may cause the valve/actuator assembly to stroke. To avoid personal injury and property damage caused by the release of pressure or process fluid, provide some temporary means of control for the process.

- *Tuning Set*—There is a choice of tuning sets to choose from. Each tuning set provides a preselected value for the digital valve controller gain settings. Tuning set C provides the slowest response and M provides the fastest response.

- *Input Char*—Defines the relationship between the travel target and ranged set point. Ranged set point is the input to the characterization function. If the zero control signal equals closed, then a set point of 0% corresponds to a ranged input of 0%. If the zero control signal equals open, a set point of 0% corresponds to a ranged input of 100%. Travel target is the output from the characterization function.

To select an input characterization, choose *Select Input Char* from the *Input Char* menu. You can select from the three fixed input characteristics shown in figure 4-2 or you can select a custom characteristic. Figure 4-2 shows the relationship between the travel target and ranged set point for the fixed input characteristics, assuming the Zero Control Signal is configured as closed.

You can specify 21 points on a custom characteristic curve. Each point defines a travel target, in % of ranged travel, for a corresponding set point, in % of ranged set point. Set point values range from -6.25% to 106.25%. Before modification, the custom characteristic is linear.

To define a custom input characteristic, from the *Input Char* menu select *Define Custom Char*. Select the point you wish to define (1 to 21), then enter the desired set point value. Press Enter then enter the desired travel target for the corresponding set point. When finished, select point 0 to return to the *Input Char* menu.

With input characterization you can modify the overall characteristic of the valve and instrument combination. Selecting an equal percentage, quick opening, or custom (other than the default of linear) input characteristic modifies the overall valve and instrument characteristic. However, if you select the linear input characteristic, the overall valve and instrument characteristic is the characteristic of the valve, which is determined by the valve trim (i.e., the plug or cage).

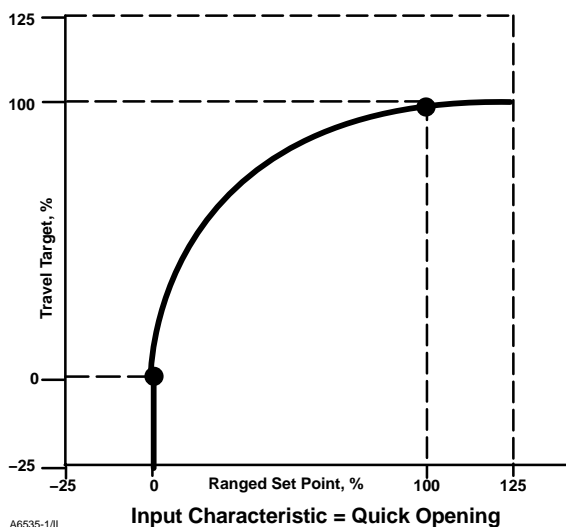
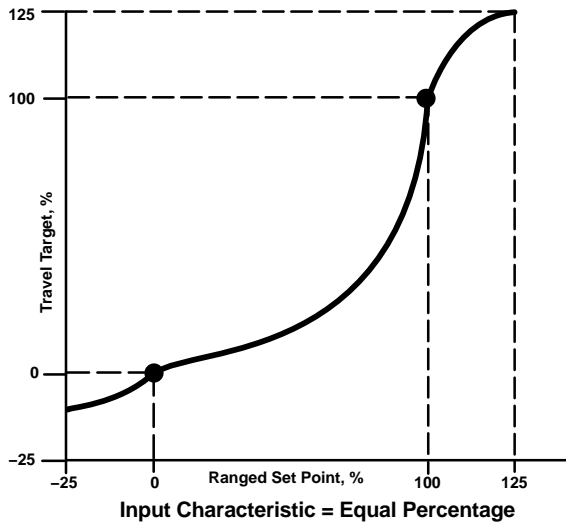
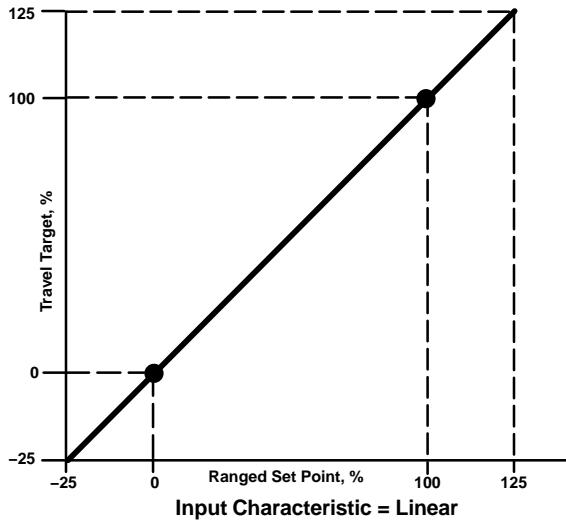

A8535-1/IL

Figure 4-2. Travel Target Versus Ranged Set Point, for Various Input Characteristics (Zero Control Signal = Closed)

- **Set Point Filter Time**—Time constant for the set point filter, in seconds. The set point filter slows the response of the digital valve controller and is typically used with noisy or fast processes. The filter provides improved closed loop process control. To disable the filter, set the time constant to 0 seconds.

- **Min Opening Time**—Minimum Opening Time is configured in seconds and defines the minimum time for the travel to increase the entire ranged travel. This rate is applied to any travel increases. A value of 0.0 seconds deactivates this feature and allows the valve to stroke open as fast as possible.

- **Min Closing Time**—Minimum Closing Time is configured in seconds and defines the minimum time for the travel to decrease the entire ranged travel. This rate is applied to any travel decreases. A value of 0.0 seconds deactivates this feature and allows the valve to stroke closed as fast as possible.

- **Integral Gain**—By setting this value to 0, the positioner integrator is disabled. Any other value will provide reset action to improve static performance.

- **Integral Deadband**—When the travel target and actual target deviate by less than this amount, the integrator is automatically disabled. This prevents the positioner integrator from fighting with the process controller integrator which may result in valve oscillation.

Setting Travel Limits and Cutoffs

Select *Setup & Diag*, *Detailed Setup*, *Response Control*, and *Limits & Cutoffs*. Follow the prompts on the Field Communicator display to set the *Tvl Limit High* (Travel Limit High), *Tvl Limit Low* (Travel Limit Low), *Tvl Cutoff High* (Travel Cutoff High), and *Tvl Cutoff Low* (Travel Cutoff Low).

- **Tvl Limit High**—Travel Limit High defines the high limit for the travel in percent (%) of ranged travel. It is the maximum allowable travel (in percent of ranged travel) for the valve. During operation, the travel target will not exceed this limit. When a Travel Limit High is set, the Travel Cutoff High is deactivated, since only one of these parameters can be active. Travel Limit High is deactivated by setting it to 125.0%.

- **Tvl Limit Low**—Travel Limit Low defines the low limit for the travel in percent (%) of ranged travel. It is the minimum allowable travel (in percent of ranged travel) for the valve. During operation, the travel target will not exceed this limit. When a Travel Limit Low is set, the Travel Cutoff Low is deactivated, since only one of these parameters can be active. Travel Limit Low is deactivated by setting it to -25.0%.

- **Tvl Cutoff High**—Travel Cutoff High defines the high cutoff point for the travel in percent (%) of ranged travel. Above this cutoff, the travel target is set to 123.0% of the ranged travel. When a Travel Cutoff High is set, the Travel Limit High is deactivated, since only one of these parameters can be active. Travel Cutoff High is deactivated by setting it to 125.0%.

- **Tvl Cutoff Low**—Travel Cutoff Low defines the low cutoff point for the travel. Travel Cutoff Low can be used to ensure proper seat load is applied to the valve. When below the travel cutoff low, the output is set to zero or to full supply pressure, depending upon the zero control signal. A Travel Cutoff Low of 0.5% is recommended to help ensure maximum shutoff seat loading.

When a Travel Cutoff Low is set, the Travel Limit Low is deactivated, since only one of these parameters can be active. Travel Cutoff Low is deactivated by setting it to -25.0%.

Setting Alerts

The alert record can store up to 20 alerts from any of the enabled alert groups: Valve Alerts, Failure Alerts, or Miscellaneous Alerts. Starting from a cleared database, the first 20 alerts that become active will be stored in memory.

Select *Setup & Diag*, *Detailed Setup*, *Alerts*, and *Alert Record*. Follow the prompts on the Field Communicator display to *Display Record*, *Clear Record*, set the *Inst Date & Time* (Instrument Date and Time), and enable *Record Groups*.

- **Display Record**—Displays all recorded alerts and the date and time the alerts were recorded.

- **Clear Record**—Clears the alert record. To clear the alert record, all alerts in enabled groups must be inactive.

- **Inst Date & Time**—Permits setting the instrument clock. When alerts are stored in the alert record, the date and time (obtained from the instrument clock) that they were stored is also stored in the record. The instrument clock uses a 24-hour format. Enter the date and time in the form: MM/DD/YYYY HH:MM:SS, where MM is two digits for the month (1 through 12), DD is two digits for the day (1 through 31), and YYYY is four digits for the year (1980 through 2040), HH is two digits for the hour (00 to 23), MM is two digits for the minutes (00 to 59), and SS is two digits for the seconds (00 through 59).

- **Record Group Enab**—Permits enabling one or more alert groups. Table B-2 lists the alerts included in

each of the groups. When any alert from an enabled group becomes active, active alerts in all enabled groups are stored.

Self Test Failures for Instrument Shutdown

Select *Setup & Diag*, *Detailed Setup*, and *Self Test Shutdown*. Follow the prompts on the Field Communicator display to determine the self test shutdown criteria from the following selections: *Done*, *Flash ROM Fail* (Flash Read Only Memory Failure), *No Free Time*, *Ref Voltage Fail* (Reference Voltage Failure), *Drive Current Fail*, *Critical NVM Fail* (Critical Non-Volatile Memory Failure), *Temp Sensor Fail* (Temperature Sensor Failure), *Press Sensor Fail* (Pressure Sensor Failure), or *Tvl Sensor Fail* (Travel Sensor Failure). Upon shutdown, the instrument attempts to drive its output pressure to the zero current condition and no longer executes its control function. In addition, the appropriate failure statuses are set. Once the problem that caused the shutdown has been fixed, the instrument can be restarted by cycling the power or selecting Restart from the *Mode* menu of the Field Communicator. Also see the DVC2000 Series Digital Valve Controller Instrument Status section on page B-5 for further details about failures.

- **Done**—Select this if you are done modifying the self test shutdown criteria.

- **Flash ROM Fail**—When enabled, the instrument shuts down whenever there is a failure associated with flash ROM (read only memory).

- **No Free Time**—When enabled, the instrument shuts down whenever there is a failure associated with No Free Time.

- **Ref Voltage Fail**—When enabled, the instrument shuts down whenever there is a failure associated with the internal voltage reference.

- **Drive Current Fail**—When enabled, the instrument shuts down whenever the drive current does not read as expected.

- **Critical NVM Fail**—When enabled, the instrument shuts down whenever there is a failure associated with critical NVM (non-volatile memory).

- **Temp Sensor Fail**—When enabled, the instrument shuts down whenever there is a failure associated with the internal temperature sensor.

- **Press Sensor Fail**—When enabled, the instrument shuts down whenever there is a failure associated with the pressure sensor.

DVC2000 Series

- *Tvl Sensor Fail*—When enabled, the instrument shuts down whenever there is a failure associated with the travel sensor.

Tuning



WARNING

Changes to the tuning set may cause the valve/actuator assembly to stroke. To avoid personal injury and property damage caused by the release of pressure or process fluid, provide some temporary means of control for the process.

4

Automatic

The auto tuner is used to optimize digital valve controller tuning. It can be used on most sliding-stem and rotary designs, including Fisher and other manufacturers' products. Moreover, because the auto tuner can detect internal instabilities before they become apparent in the travel response, it can generally optimize tuning more effectively than manual tuning.

Access the auto tuner by selecting *Auto Tuner* from the *Calibrate* menu. Follow the prompts on the Field Communicator display to optimize digital valve controller tuning.

Manual

If the auto tuner does not provide the desired responsiveness, you can manually tune the DVC2000. Refer to Setting Response, page 4-7.

Calibration



WARNING

During calibration the valve will move full stroke. To avoid personal injury and property damage caused by the release of pressure or process fluid, provide some temporary means of control for the process.



Note

If optional limit switches are being used, power must be applied to the switch circuits throughout the calibration routine.



Auto Calibrate Travel

Select *Auto Calib Travel* from the *Calibrate* menu, then follow the prompts on the Field Communicator display to automatically calibrate travel.

1. The auto calibration procedure is automatic. It is completed when the *Calibrate* menu appears.

During calibration, the instrument seeks the high and low end points and the minor loop feedback (MLFB) and output bias. By searching for the end points, the instrument establishes the limits of physical travel, i.e., the actual travel 0 and 100% positions. This also determines how far the relay beam swings to calibrate the sensitivity of the beam position sensor.

Adjusting the minor loop feedback bias is done around mid travel. The valve position is briefly moved back and forth to determine the relay beam position at quiescence. Essentially, it establishes the zero point for the Minor Loop Feedback circuit. The back and forth motion is performed to account for hysteresis.

Adjusting the output bias aligns the travel set point with the actual travel by computing the drive signal required to produce 0% error. This is done while the valve is at 50% travel, making very small adjustments.

2. Place the instrument In Service and verify that the travel properly tracks the current source.



Manual Calibrate Travel

Two procedures are available to manually calibrate travel:

- Analog Adjust
- Digital Adjust



Analog Calibration Adjust

From the *Calibrate* menu, select *Man Calib Travel* and *Analog Adjust*. Connect a variable current source to

Advanced Setup and Calibration

the instrument LOOP + and LOOP – terminals. The current source should be capable of generating 4 to 20 mA. Follow the prompts on the Field Communicator display to calibrate the instrument's travel in percent.



Note

0% Travel = Valve Closed
100% Travel = Valve Open

1. Adjust the input current until the valve is near mid-travel. Press OK.



Note

In steps 2 through 4, the accuracy of the current source adjustment affects the position accuracy.

2. Adjust the current source until the valve is at 0% travel, then press OK.
3. Adjust the current source until the valve is at 100% travel, then press OK.
4. Adjust the current source until the valve is at 50% travel, then press OK.
5. Place the instrument In Service and verify that the travel properly tracks the current source.



Digital Calibration Adjust

From the *Calibrate* menu, select *Man Calib Travel* and *Digital Adjust*. Connect a variable current source to the instrument LOOP + and LOOP – terminals. The current source should be set between 4 and 20 mA. Follow the prompts on the Field Communicator display to calibrate the instrument's travel in percent.



Note

0% Travel = Valve Closed
100% Travel = Valve Open

1. From the adjustment menu, select the direction and size of change required to set the travel at 0%.

If another adjustment is required, repeat step 1. Otherwise, select Done and go to step 2.

2. From the adjustment menu, select the direction and size of change required to set the travel to 100%.

If another adjustment is required, repeat step 2. Otherwise, select Done and go to step 3.

3. From the adjustment menu, select the direction and size of change required to set the travel to 50%.

If another adjustment is required, repeat step 3. Otherwise, select Done and go to step 4.

4. Place the instrument In Service and verify that the travel properly tracks the current source.

4

Analog Input Calibration



To calibrate the analog input sensor, connect a variable current source to the instrument LOOP+ and LOOP– terminals. The current source should be capable of generating an output of 4 to 20 mA. Select *Analog In Calib* from the *Calibrate* menu, then follow the prompts on the Field Communicator display to calibrate the analog input sensor.

1. Set the current source to the target value shown on the display. The target value is the Input Range Low value. Press OK.

2. The following message appears:

Use Increase and Decrease selections until the displayed current matches the target.

Press OK when you have read this message.

3. The value of the Analog Input appears on the display. Press OK to display the adjustment menu.

4. From the adjustment menu, select the direction and size of adjustment to the displayed value. Selecting large, medium, and small adjustments causes changes of approximately 0.4 mA, 0.04 mA, and 0.004 mA, respectively. If the displayed value does not match the current source, press OK, then repeat this step (step 4) to further adjust the displayed value. When the displayed value matches the current source, select Done and go to step 5.

5. Set the current source to the target value shown on the display. The target value is the Input Range High value. Press OK.

DVC2000 Series

6. The following message appears:

Use Increase and Decrease selections until the displayed current matches the target.

Press OK when you have read this message.

7. The value of the Analog Input appears on the display. Press OK to display the adjustment menu.

8. From the adjustment menu, select the direction and size of adjustment to the displayed value. Selecting large, medium, and small adjustments causes changes of approximately 0.4 mA, 0.04 mA, and 0.004 mA, respectively. If the displayed value does not match the current source, press OK, then repeat this step (step 8) to further adjust the displayed value. When the displayed value matches the current source, select Done and go to step 9.

9. Place the instrument In Service and verify that the analog input displayed matches the current source.

1. Adjust the supply pressure regulator to the maximum instrument supply pressure. Press OK.

2. The instrument reduces the output pressure to 0. The following message appears.

Use the Increase and Decrease selections until the displayed pressure matches the output x pressure.

Press OK when you have read the message.

3. The value of the output pressure appears on the display. Press OK to display the adjustment menu.

4. From the adjustment menu, select the direction and size of adjustment to the displayed value. Selecting large, medium, and small adjustments causes changes of approximately 3.0 psi/0.207 bar/20.7 kPa, 0.30 psi/0.0207 bar/2.07 kPa, and 0.03 psi/0.00207 bar/0.207 kPa, respectively. If the displayed value does not match the output pressure, press OK, then repeat this step (step 4) to further adjust the displayed value. When the displayed value matches the output pressure, select Done and go to step 5.

5. The instrument sets the output pressure to full supply. The following message appears.

Use the Increase and Decrease selections until the displayed pressure matches the output x pressure.

Press OK when you have read the message.

6. The value of the output pressure appears on the display. Press OK to display the adjustment menu.

7. From the adjustment menu, select the direction and size of adjustment to the displayed value. Selecting large, medium, and small adjustments causes changes of approximately 3.0 psi/0.207 bar/20.7 kPa, 0.30 psi/0.0207 bar/2.07 kPa, and 0.03 psi/0.00207 bar/0.207 kPa, respectively. If the displayed value does not match the output pressure, press OK, then repeat this step (step 7) to further adjust the displayed value. When the displayed value matches the output pressure, select Done and go to step 8.

8. Place the instrument In Service and verify that the displayed pressure matches the measured output pressure.

4

Pressure Sensor Calibration



Note

The pressure sensor is calibrated at the factory and should not require calibration.

Output Pressure Sensor Calibration

To calibrate the output pressure sensor, connect an external reference gauge to the output being calibrated. The gauge should be capable of measuring maximum instrument supply pressure. From the *Calibrate* menu, select *Pressure Calib*. Follow the prompts on the Field Communicator display to calibrate the instrument's output pressure sensor.

Section 5 Maintenance

Replacing the Instrument	5-2
Replacing the Magnetic Feedback Assembly	5-2
Component Replacement	5-3
Replacing the Main Electronics	5-3
Replacing the Secondary Electronics	5-4
Replacing the I/P Converter	5-5
Replacing the Pneumatic Relay	5-6



DVC2000 Series

The DVC2000 Series digital valve controller has the capability to provide predictive maintenance information through the use of AMS ValveLink Software. This software allows you to pinpoint instrument and valve problems without disrupting the process. For information on using AMS ValveLink Software, see the AMS ValveLink Software User Guide.

WARNING

Avoid personal injury or property damage from sudden release of process pressure or bursting of parts. Before performing any maintenance procedures on the the DVC2000 Series digital valve controller:

- Always wear protective clothing and eyewear when performing any maintenance procedures to avoid personal injury.
- Disconnect any operating lines providing air pressure, electric power, or a control signal to the actuator. Be sure the actuator cannot suddenly open or close the control valve.
- Use bypass valves or completely shut off the process to isolate the control valve from process pressure. Relieve process pressure from both sides of the control valve. Drain the process media from both sides of the control valve.
- Vent the pneumatic actuator loading pressure and relieve any actuator spring precompression.
- Use lock-out procedures to be sure that the above measures stay in effect while you work on the equipment.
- Check with your process or safety engineer for any additional measures that must be taken to protect against process media.

Replacing the Instrument

To replace an instrument that has been previously mounted to a control valve, perform the following basic steps:

Instrument Removal

1. Make sure that the valve is isolated from the process.
2. Remove the instrument cover (refer to figure 5-1).
3. Disconnect the field wiring from the terminal board.
4. Shut off the instrument air supply and disconnect the tubing to the supply port.
5. Disconnect the tubing from the output port.
6. Remove the bolts connecting the DVC2000 housing to the mounting bracket.



Note

The magnet assembly may remain on the valve stem (or shaft).

When replacing the instrument, be sure to follow the mounting procedure outlined in Section 2. Once the instrument is mounted, perform the Quick Setup routine outlined in Section 3. If changes need to be made to the default settings, use the Detailed Setup routine to make the appropriate modifications.

Replacing the Magnetic Feedback Assembly

To remove the magnet assembly from the actuator stem, perform the following basic steps.

1. Make sure that the valve is isolated from the process.
2. Remove the instrument cover.
3. Disconnect the field wiring from the terminal board.
4. Shut off the instrument air supply.
5. Remove the DVC2000 from the actuator.
6. Remove the screws holding the magnet assembly to the connector arm.

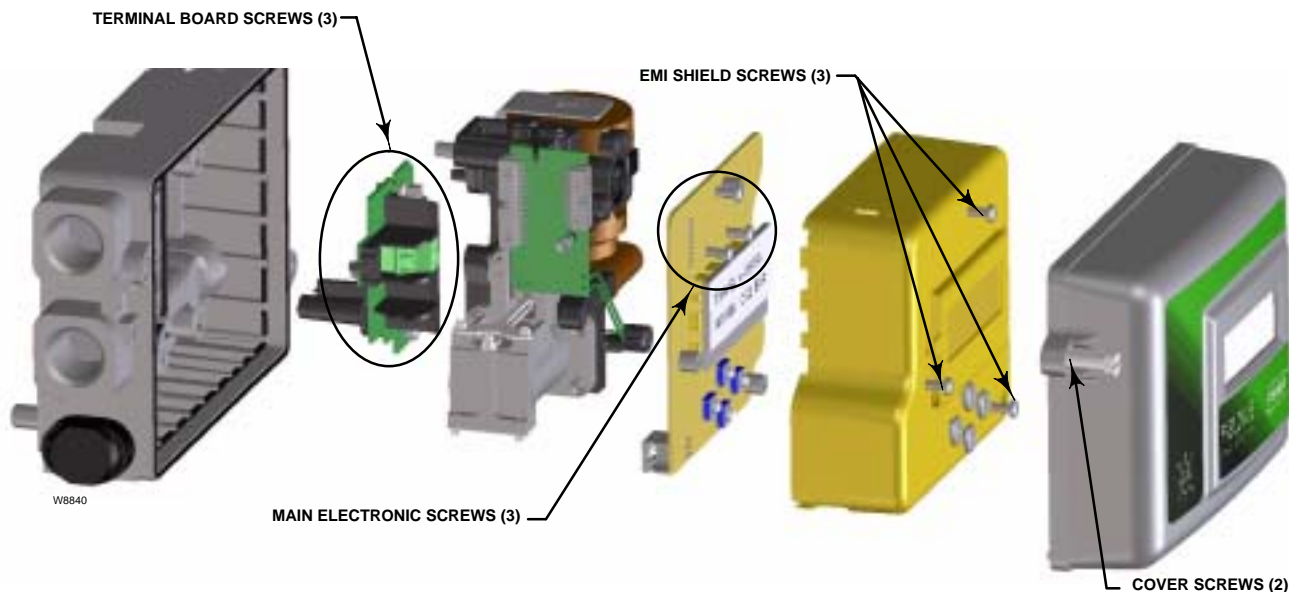

Figure 5-1. DVC2000 Exploded View

When replacing the instrument, be sure to follow the mounting procedure outlined in Section 2. Once the instrument is mounted, perform the Quick Setup routine outlined in Section 3. If changes need to be made to the default settings, use the Detailed Setup routine to make the appropriate modifications.



Note

After replacing the main electronics board, recalibrate and configure the digital valve controller to maintain accuracy specifications.

Component Replacements

When replacing any of the components of the DVC2000, the maintenance should be performed in an instrument shop whenever possible. Make sure that the electrical wiring and pneumatic tubing is disconnected prior to disassembling the instrument.

CAUTION

When replacing components, proper means of electrostatic discharge protection is required. Failure to use a grounding strap, or other means of electrostatic discharge protection can result in damage to the electronics.

Removal

1. Remove the main cover.
2. Remove three screws that hold the EMI shield and remove the shield (refer to figure 5-1).
3. Remove the three screws holding the electronics board to the mounting frame (refer to figure 5-1).
4. Pull the main electronics straight off of the mounting frame. The board is electrically connected to an interconnecting board with a rigid connector.

Installation

When installing a new board, follow the reverse procedure as outlined above and recalibrate the instrument. Take care to align the rigid connector properly, and install the pressure sensor O-ring before installing the three fasteners.

Replacing the Main Electronics

The main electronics contains the liquid crystal display, pushbuttons, and microprocessor with firmware. Calibration and configuration data is stored on the main electronics board.

DVC2000 Series

Replacing the Secondary Electronics

The secondary electronics contains the wiring terminations and the feedback sensor circuitry. Additionally, any optional electronics (limit switches and position transmitter) reside on the secondary electronics.



Note

After secondary electronics replacement, calibrate the digital valve controller to maintain accuracy specifications.

5

Removal

1. Remove the main cover.
2. Remove three screws that hold the EMI shield and remove the shield (refer to figure 5-1).
3. Remove the three screws holding the electronics board to the mounting frame (refer to figure 5-1).
4. Pull the main electronics straight off of the mounting frame. The board is electrically connected to an interconnecting board with a rigid connector.
5. Remove the two screws holding the mounting frame to the instrument housing (refer to figure 5-3).
6. Pull the mounting frame straight out. The interconnecting board is electrically connected to the termination board with a rigid connector.
7. Remove the small board from the I/P converter pins.
8. Remove the interconnect board from the mounting frame.
9. Remove the three screws holding the terminal board to the housing (refer to figure 5-1).
10. Pull the terminal board straight out of the housing.

Assembly

1. Replace the short conductive gasket (key 24) if necessary.
2. Place the O-ring seal (key 32) into the groove where the feedback sensor extends out through the housing.

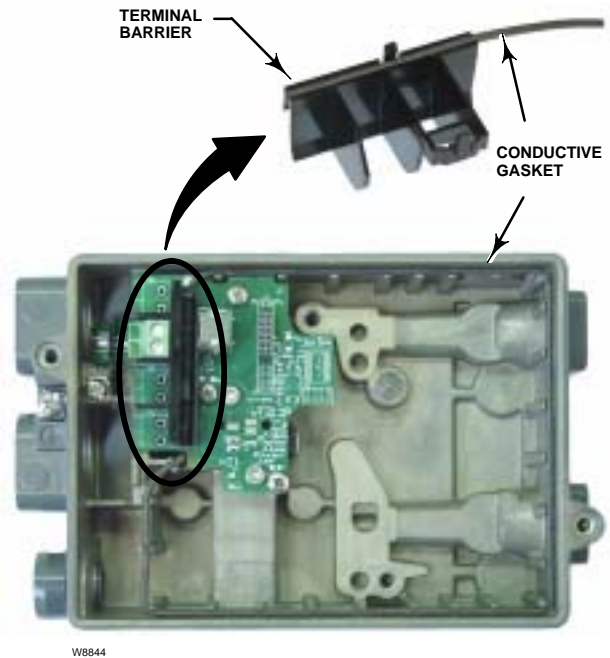

Figure 5-2. Installation of Conductive Gasket



Note

The proper placement of this O-ring is critical to maintaining proper ingress protection.

3. Place the termination/sensor board in the housing, taking care not to pinch the O-ring seal.
4. Tighten the 3 fasteners (keys 11 and 15).
5. Place the long conductive gasket (key 29) in the terminal barrier (key 36) as shown in figure 5-2.
6. Snap the terminal barrier to the terminal board assembly and place the conductive gasket along the perimeter of the DVC2000 housing.
7. Install the I/P and Interconnect boards to the Mounting Frame. Do not tighten the self-tapping screws on the interconnect board (key 42) at this point. The two wires must be inserted into the plastic wire retainer on the mounting frame (Intrinsically Safe units).
8. Install the Mounting Frame to the housing, making sure that the O-rings (keys 45 and 51) are in place.
9. Install the Main Electronics to the mounting frame, making sure that the pressure sensor seal (key 16) is in place.

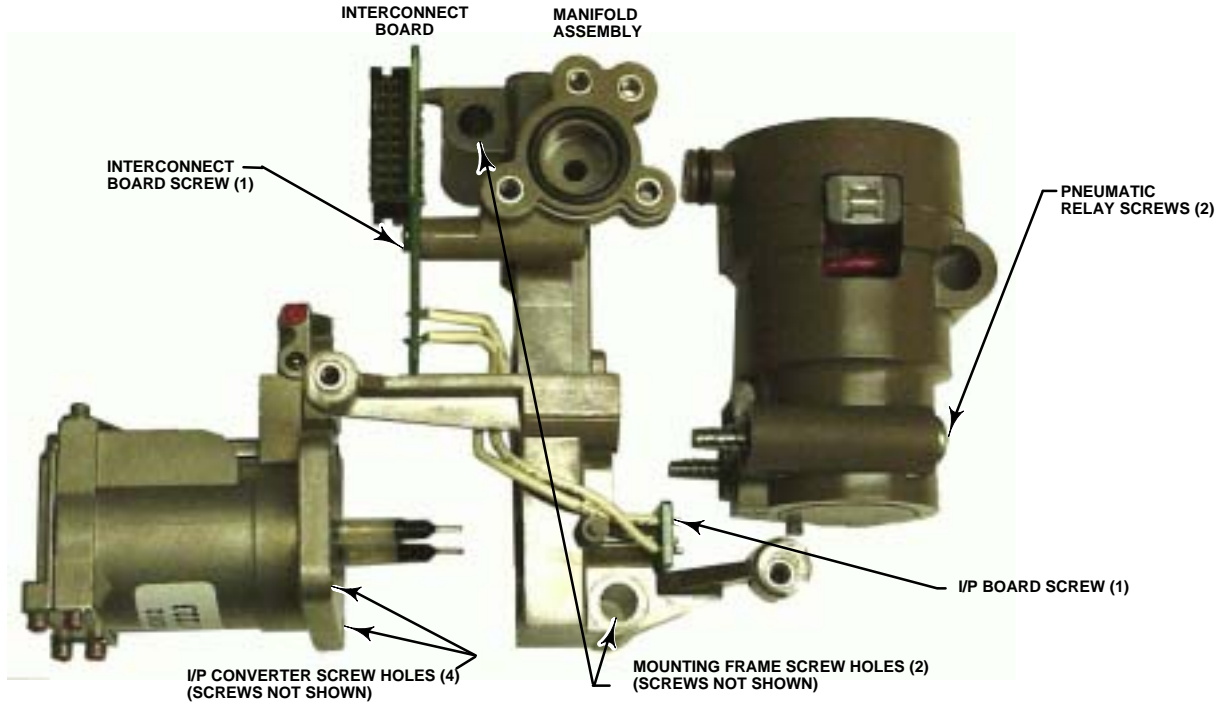

W9103

Figure 5-3. Mounting Frame Assembly

10. Tighten the self-tapping screw (key 42) on the Interconnect Board.
11. Install the Primary Shield (key 37) with three screws.
12. Recalibrate the instrument and install the cover.

Replacing the I/P Converter

The I/P converter is fastened to the mounting frame. On the I/P mounting surface is a replaceable screen with O-ring seal.



Note

After I/P converter replacement, calibrate the digital valve controller to maintain accuracy specifications.

Removal

1. Remove the main cover.
2. Remove three screws that hold the EMI shield and remove the shield (refer to figure 5-1).

3. Remove the three screws holding the electronics board to the mounting frame.
4. Pull the main electronics straight off of the mounting frame. The board is electrically connected to an interconnecting board with a rigid connector.
5. Remove the two screws holding the mounting frame to the instrument housing (refer to figure 5-3 for location of screws).
6. Pull the manifold assembly straight out. The interconnecting board is electrically connected to the termination board with a rigid connector.
7. Remove the interconnect board from the mounting frame.
8. Remove the four screws holding the I/P converter to the mounting frame (refer to figure 5-3 for location of screws).
9. Pull the I/P converter straight out taking care to capture the two o-rings (one has a screen).

Assembly

When installing a new I/P converter, follow the reverse procedure as outlined above and recalibrate the instrument.

1. Install the I/P converter, making sure the screen O-ring is installed on the I/P supply port (the circular port on the mounting frame), and that the two manifold O-rings are in place.

DVC2000 Series

2. Install the interconnect board on the mounting frame. Do not tighten the self-tapping screw on the interconnect board (key 42) at this time.
3. Replace the manifold assembly.
4. Install the Mounting Frame to the housing, making sure that the o-rings (keys 45 and 51) are in place.
5. Install the Main Electronics to the mounting frame, making sure that the pressure sensor seal (key 16) is in place.
6. Tighten the self-tapping screw (key 42) on the Interconnect Board.
7. Install the Primary Shield (key 37) with three screws.
8. Recalibrate the instrument and install the cover.

5

Replacing the Pneumatic Relay

The pneumatic relay is fastened to the mounting frame. There are two versions, 0 to 3.4 bar (0 to 49 psig), indicated by a white label, and 3.5 to 7 bar (50 to 100 psig), indicated by a green label.



Note

After pneumatic relay replacement, calibrate the digital valve controller to maintain accuracy specifications.

Removal

1. Remove the main cover.
2. Remove three screws that hold the EMI shield and remove the shield (refer to figure 5-1).
3. Remove the three screws holding the electronics board to the mounting frame.
4. Pull the main electronics straight off of the mounting frame. The board is electrically connected to an interconnecting board with a rigid connector.
5. Remove the two screws holding the mounting frame to the instrument housing (refer to figure 5-3).
6. Pull the mounting frame straight out. The interconnecting board is electrically connected to the termination board with a rigid connector.
7. Remove the two screws holding the pneumatic relay to the mounting frame.
8. Pull the pneumatic relay straight out.

Assembly

When installing a new pneumatic relay, follow the reverse procedure as outlined above and recalibrate the instrument.

Section 6 Replaceable Parts

Parts Ordering	6-2
Parts Kits	6-2
Parts List	6-2

DVC2000 Series

Parts Ordering

Whenever corresponding with your Fisher sales office about this equipment, always mention the controller serial number. When ordering replacement parts, refer to the 11-character part number of each required part as found in the following parts list. Parts which do not show part numbers cannot be ordered.



Note

Use only genuine Fisher replacement parts. Components that are not supplied by Fisher should not, under any circumstances, be used in any Fisher instrument. Use of components not supplied by Fisher will void your warranty, might adversely affect the performance of the valve, and might jeopardize worker and workplace safety.

6

The DVC2000 Series digital valve controller is designed with all metric fasteners and threaded connections. However, optional inch connections are available for the two conduit entrance points (1/2-inch NPT) and the supply/output pneumatic ports (1/4-inch NPT). Even with this option, all other fasteners and threaded connections are metric.



Note

Neither Emerson, Emerson Process Management, Fisher, nor any of their affiliated entities assumes responsibility for the selection, use and maintenance of any product. Responsibility for the selection, use and maintenance of any product remains with the purchaser and end-user.

Parts Kits

Description	Part Number
Terminal Board Kit (positioner only)	GE08906X012
Terminal Board Kit (positioner, transmitter, limit switches)	GE08907X012
Main Board Kit (base AC tier)	GE08908X012
I/P Converter Kit	GE08909X012

Description	Part Number
Low Pressure Relay Kit (white label) (0 – 3.4 bar, 0 – 49 psig)	GE08910X012
High Pressure Relay Kit (green label) (3.5 – 7.0 bar, 50 – 100 psig)	GE08911X012
Mounting Frame Kit	GE08912X012
Main Cover Assembly (see figure 6-1, key 13)	GE12427X012
EMI Shield Kit	GE08913X012
25 mm (1-inch) Feedback Array	GE09169X012
50 mm (2-inch) Feedback Array	GE09170X012
Rotary Feedback Kit	GE09171X012
Elastomer Kit – includes all accessible elastomers for one complete DVC2000 unit	GE08917X012
Small Hardware Kit –includes all fasteners and plugs (except mounting hardware) for one complete DVC2000 unit	GE08918X012

Parts List (refer to figures 6-1, 6-2 and 6-3)



Note

The parts contained in the Parts List are not available as individual components. All parts are included in the Parts Kits.

Key Description

Terminal Board Assembly⁽¹⁾

4	Feedback Sensor & Termination Boards , with Options
11	Fasteners
15	Fastener
24	Conductive Gasket (PWB)
29	Conductive Gasket (Shield)
30	Fastener
32	O-ring seal
36	Terminal Barrier
42	Fasteners
43	Interconnect and I/P Boards

1. All parts included in the Terminal Board Kits

Replaceable Parts

Key Description

Main Board Assembly (Base AC Tier)⁽²⁾

15 Fasteners
16 Pressure Sensor Seal
35 Main Board with LCD and Pushbuttons

I/P Converter Assembly⁽³⁾

25 Fasteners
26 O-Ring
41 I/P Converter
231 Screen O-Ring

Relay Assembly⁽⁴⁾

2 Relay
45 O-Rings

Key Description

Mounting Frame Assembly⁽⁵⁾

3 Mounting Frame
16 Pressure Sensor Seal
19 Fasteners
45 O-Ring
51 O-Ring

EMI Shield Assembly⁽⁶⁾

11 Fasteners (3 req'd)
29 Conductive Gasket (Shield)
37 Primary Shield

6

2. All parts included in the Main Board Kit
3. All parts included in the I/P Converter Kit
4. All parts included in the Low Pressure or High Pressure Relay Kits
5. All parts included in the Mounting Frame Kit
6. All parts included in the EMI Shield Kit

DVC2000 Series

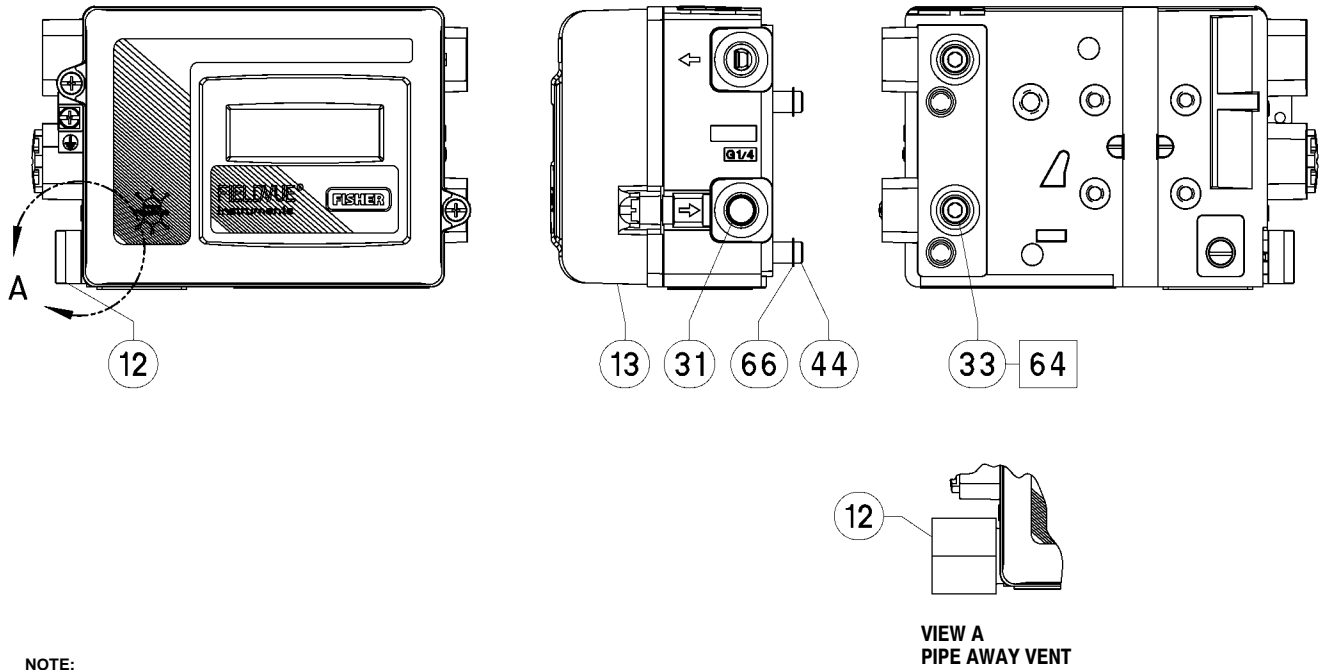

6

NOTE:
 1. APPLY LUBRICANT KEY 65 TO ALL O-RINGS
 UNLESS OTHERWISE SPECIFIED
 □ APPLY LUBRICANT/SEALANT

10C3558-A, SHEET 1 OF 3

Figure 6-1. Type DVC2000 Digital Valve Controller Assembly, Housing A

Replaceable Parts

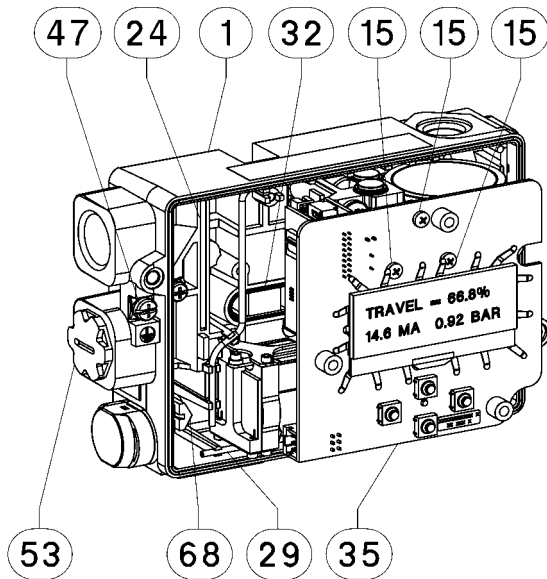
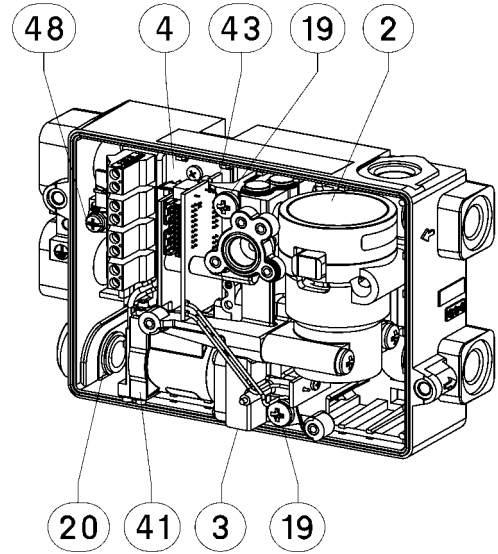
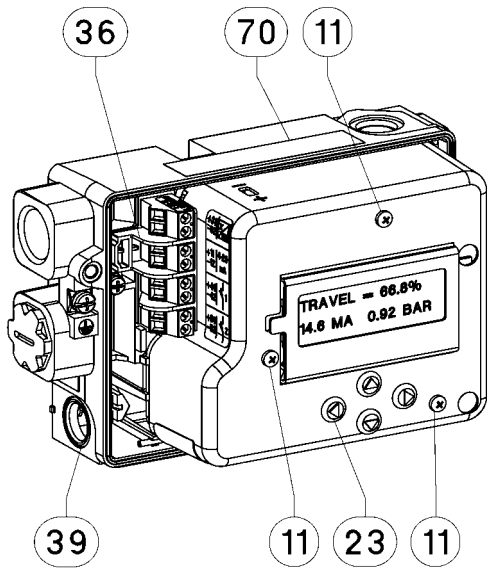

6

NOTE:
 1. APPLY LUBRICANT KEY 65 TO ALL O-RINGS
 UNLESS OTHERWISE SPECIFIED
 APPLY LUBRICANT/SEALANT

10C3558-A, SHEET 2 OF 3

Figure 6-2. Type DVC2000 Digital Valve Controller Assembly, Housing A

DVC2000 Series

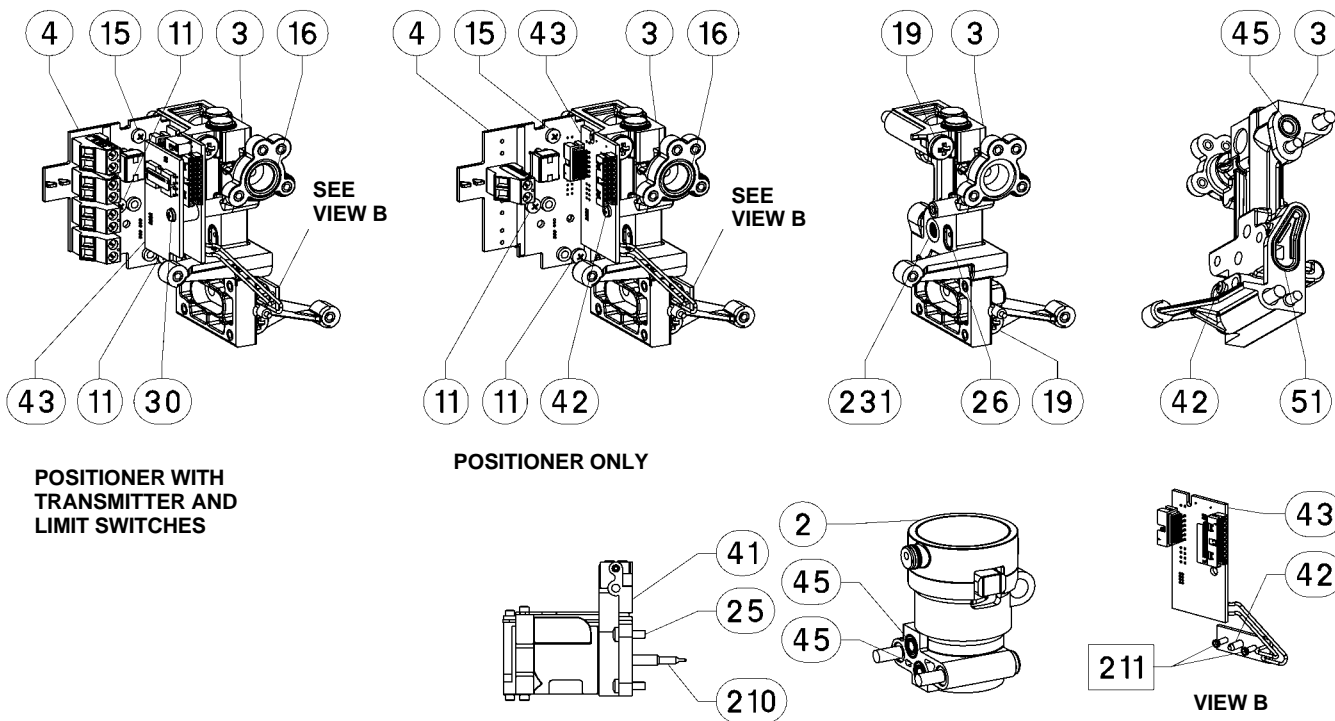

NOTE:
 1. APPLY LUBRICANT KEY 65 TO ALL O-RINGS
 UNLESS OTHERWISE SPECIFIED
 APPLY LUBRICANT/SEALANT

10C3558-A, SHEET 2 OF 3

Figure 6-3. Type DVC2000 Digital Valve Controller Assembly, Housing A

Appendix A Specifications

Specifications A-2

DVC2000 Series

Specifications

Available Configurations

- Integral mounting to the Design GX Control Valve and Actuator System
- Sliding stem applications
- Quarter-turn rotary applications

DVC2000 Series positioners can also be mounted on other actuators that comply with IEC 60534-6-1, IEC 60534-6-2, VDI/VDE 3845 and NAMUR mounting standards.

Input Signal

Analog Input Signal: 4–20mA dc, nominal; split ranging available.

Minimum Voltage: Voltage available at instrument terminals must be 8.5 volts for analog control, 9.0 volts for HART communication.

Maximum Voltage: 30 volts dc

Minimum Control Current: 4.0 mA (below 3.5 mA may cause microprocessor restart)

Overcurrent Protection: Input circuitry limits current to prevent internal damage.

Reverse Polarity Protection: No damage occurs from reversal of loop current.

Output Signal

Pneumatic signal as required by the actuator, up to 95% of supply pressure

Minimum Span: 0.5 bar (7 psig)

Maximum Span: 7 bar (101 psig)

Action: Single Acting, direct

Supply Pressure⁽¹⁾

Recommended: 0.5 bar (7 psig) greater than the maximum actuator requirements

Maximum: 7 bar (101 psig)

Declaration of SEP

Fisher Controls International LLC declares this product to be in compliance with Article 3 paragraph 3 of the Pressure Equipment Directive (PED) 97 / 23 / EC. It was designed and manufactured in accordance with Sound Engineering Practice (SEP) and cannot bear the CE marking related to PED compliance.

However, the product *may* bear the CE marking to indicate compliance with *other* applicable EC Directives.

Temperature Limits⁽¹⁾

–40 to 85°C (–40 to 185°F). LCD may not be readable below –20°C (–4 °F).

See the Hazardous Area Classification bulletins for specific ambient temperature limits of units approved for operation in hazardous areas.

Air Consumption⁽²⁾

Supply pressure:

At 1.5 bar (22 psig)⁽³⁾: 0.06 normal m³/h (2.3 scfh)

At 4 bar (58 psig)⁽⁴⁾: 0.12 normal m³/h (4.4 scfh)

Air Capacity⁽²⁾

Supply pressure:

At 1.5 bar (22 psig)⁽³⁾: 4.48 normal m³/h (167 scfh)

At 4 bar (58 psig)⁽⁴⁾: 9.06 normal m³/h (338 scfh)

Independent Linearity

±0.5% of output span

Electromagnetic Interference (EMI)

Tested per IEC 61326-1 (Edition 1.1). Complies with European EMC Directive. Meets emission limits for class A equipment (industrial locations) and class B equipment (domestic locations). Meets immunity requirements for industrial locations (Table A.1 in the IEC specification document). Immunity performance is shown in table A-1.

Electrical Classification

Hazardous Area:



Intrinsically Safe and Non-incendive



Intrinsically Safe and Non-incendive

ATEX Intrinsically Safe

IECEX Intrinsically Safe

Refer to tables A-2 and A-3, figures A-1, A-2, A-3, A-4, A-5, A-6 and A-7, and Hazardous Area Classification Bulletins 9.2:001 series for additional information.

Electrical Housing: Designed to meet IP66⁽⁵⁾

–continued–

Specifications (continued)

Connections

Standard

Supply and Output Pressure: G1/4 female

Electrical: M20 female

Optional

Supply and Output Pressure: 1/4-inch NPT female

Electrical: 1/2-inch NPT female

Materials of Construction

Housing and Cover: ASTM B85 A03600 low copper aluminum alloy

Elastomers: nitrile, fluorosilicone

Stem Travel

Minimum: 8 mm (0.3125 inch)

Maximum: 50 mm (2-inches)

Shaft Rotation

Minimum: 45°

Maximum: 90°

Mounting

Designed for direct actuator mounting. For weatherproof housing capability, the vent must be positioned at the lowest point of the instrument.

Weight

1.5 kg (3.3 lbs)

Options

■ *Airset:* Type 67CFR with filter

■ *Language:* German, French, Italian, Spanish, Chinese, Japanese, English

■ Pipe-away vent

■ *Limit Switches:* Two isolated switches, configurable throughout calibrated travel range

Supply Voltage: 5–30 VDC

OFF State: 0.5 to 1.0 mA

ON State: 3.5 to 4.5 mA (above 5V)

Reference Accuracy: 2% of travel span⁽⁶⁾

■ *Transmitter:* 4–20 mA output, isolated

Supply Voltage: 8–30 VDC

Fault Indication: offrange high or low

Reference Accuracy: 1% of travel span⁽⁶⁾

1. The pressure/temperature limits in this document and any applicable standard or code limitation should not be exceeded. Note: Temperature limits vary based on hazardous area approval.
2. Normal m³/hour – Normal cubic meters per hour at 0°C and 1.01325 bar, absolute. Scfh – Standard cubic feet per hour at 60°F and 14.7 psia.
3. Low pressure relay: 0 to 3.4 bar (0 to 50 psig).
4. High pressure relay: 3.5 to 7.0 bar (51 to 102 psig).
5. Approval pending. Contact your Fisher Sales office for information on pending approvals.
6. Typical values when calibrated at temperature.



Table A-1. Immunity Performance

Port	Phenomenon	Basic Standard	Performance Criteria ⁽¹⁾
Enclosure	Electrostatic discharge (ESD)	IEC 61000-4-2	B
	Radiated EM field	IEC 61000-4-3	A
	Rated power frequency magnetic field	IEC 61000-4-8	A
I/O signal/control	Burst (fast transients)	IEC 61000-4-4	A
	Surge	IEC 61000-4-5	B
	Conducted RF	IEC 61000-4-6	A

Performance criteria is + / - 1% effect.
 1. A = No degradation during testing. B = Temporary degradation during testing, but is self-recovering.

DVC2000 Series

Table A-2. Hazardous Area Classifications for North America

CERTIFICATION BODY	CERTIFICATION OBTAINED	ENTITY RATINGS	TEMPERATURE CODE	ENCLOSURE RATING
CSA	(Intrinsic Safety) Zone •Ex ia IIC T4/T5 Class/Division •Class I Division 1 GP A,B,C,D per drawing GE12444	(Main Circuit) $V_{max} = 30 \text{ Vdc}$ $I_{max} = 130 \text{ mA}$ $P_i = 1.0 \text{ W}$ $C_i = 5 \text{ nF}$ $L_i = 0.55 \text{ mH}$	T4($T_{amb} < 80\text{C}$) T5($T_{amb} < 40\text{C}$)	---
	Class I Division 2 GP A,B,C,D	---	T5($T_{amb} < 80\text{C}$)	---
FM	(Intrinsic Safety) Class/Division •Class I Division 1 GP A,B,C,D per drawing GE10683	(Main Circuit) $V_{max} = 30 \text{ Vdc}$ $I_{max} = 130 \text{ mA}$ $P_i = 1.0 \text{ W}$ $C_i = 5 \text{ nF}$ $L_i = 0.55 \text{ mH}$	T4($T_{amb} < 80\text{C}$) T5($T_{amb} < 40\text{C}$)	---
	Class I Division 2 GP A,B,C,D	---	T5($T_{amb} < 80\text{C}$)	---

Table A-3. Hazardous Area Classifications for Europe and Asia-Pacific

CERTIFICATION BODY	CERTIFICATION OBTAINED	ENTITY RATINGS	TEMPERATURE CODE	ENCLOSURE RATING
ATEX (LCIE)	(Intrinsic Safety) Ⓢ II 1 G Gas •EEx ia IIC T4/T5	(Main Circuit) $V_{max} = 30 \text{ Vdc}$ $I_{max} = 130 \text{ mA}$ $P_i = 1.0 \text{ W}$ $C_i = 5 \text{ nF}$ $L_i = 0.55 \text{ mH}$	T4($T_{amb} < 80\text{C}$) T5($T_{amb} < 40\text{C}$)	---
IECEX (CSA)	(Intrinsic Safety) Gas •Ex ia IIC T4/T5	(Main Circuit) $V_{max} = 30 \text{ Vdc}$ $I_{max} = 130 \text{ mA}$ $P_i = 1.0 \text{ W}$ $C_i = 5 \text{ nF}$ $L_i = 0.55 \text{ mH}$	T4($T_{amb} < 80\text{C}$) T5($T_{amb} < 40\text{C}$)	---

A

Appendix B Principle of Operation

DVC2000 Operation	B-2
Troubleshooting	B-3
Checking Available Voltage	B-3
Viewing Variables	B-4
Viewing Device Information	B-5

DVC2000 Series

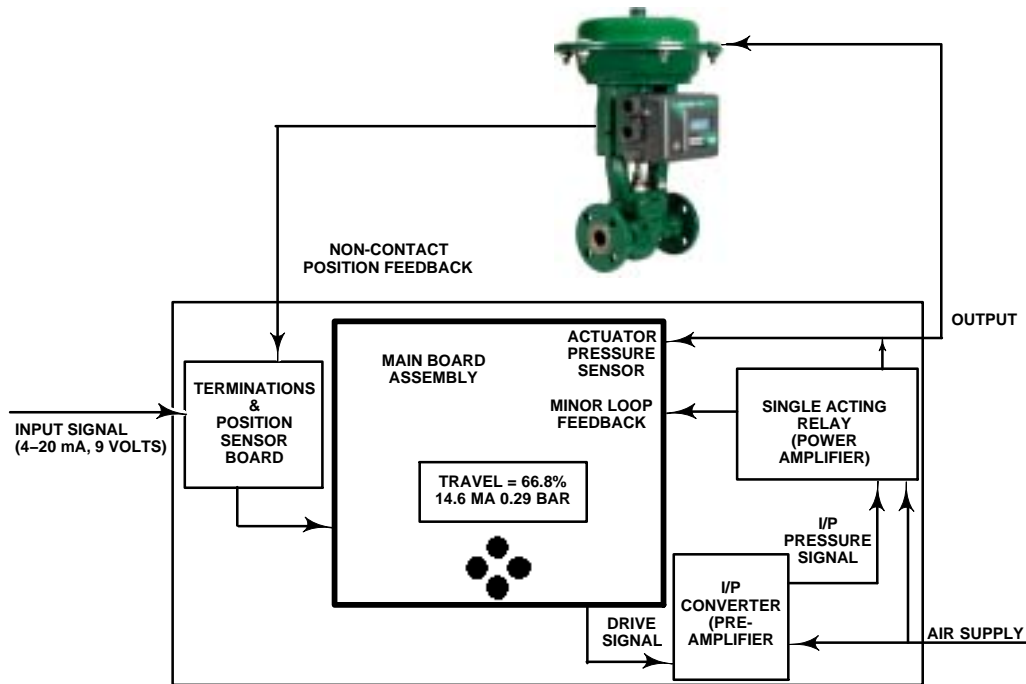

Figure B-1. DVC2000 Series Digital Valve Controller Block Diagram

DVC2000 Operation

The DVC2000 series digital valve controller uses a traditional 4–20mA input signal and converts it into a pneumatic output pressure that is delivered to the control valve actuator. Accurate control of the position of the valve is enabled by valve stem position feedback. The way in which the DVC2000 accomplishes this is through a two-stage positioner design. Refer to figure B-1 for a block diagram of the positioner operation.

A traditional 4–20 mA signal provides the set point and power to the instrument. At the same time, the HART protocol provides instrument and process data through digital communications. The instrument receives this set point and positions the valve where it needs to be.

- The **input signal** provides electrical power and the set point simultaneously. It is routed into the terminal board through a twisted pair of wires. The terminal board contains the termination points for the loop signal (+11/–12). If the options board is installed, an additional options board set includes additional terminals for the transmitter output (+31/–32), switch #1 output (+41/–42), and switch #2 output (+51/–52).

- The input signal is then directed to the main electronics board assembly where the microprocessor runs a digital control algorithm resulting in a **drive signal** to the I/P converter.

- The I/P converter assembly is connected to supply pressure and converts the drive signal into a **pressure signal**. The I/P converter is the pre-amplifier stage in the two-stage positioner design. This component enables high static gain for responsiveness to small changes in the input signal.

- The I/P output is sent to the pneumatic relay assembly. The relay is also connected to supply pressure and amplifies the small pressure signal from the I/P converter into a larger **pneumatic output signal** used by the actuator. The pneumatic relay is the power amplifier stage in the two-stage positioner design. This component enables superior dynamic performance with minimal steady-state air consumption.

- A sensor on the printed wiring board measures the motion of the small valve inside the pneumatic relay. This measurement is used for minor loop feedback to the control algorithm resulting in stable, robust tuning.

- The change in relay output pressure to the actuator causes the valve to move.

- Valve position is sensed through the non-contact, linkage-less feedback sensor. There are no moving linkages and the DVC2000 is physically separated from the valve stem through the use of a magnetic Hall effect sensor. A magnetic array is mounted to the

valve stem and the sensor is embedded in the DVC2000 housing. The sensor is electrically connected to the printed wiring board to provide a travel feedback signal used in the control algorithm.

The valve continues to move until the correct position is attained.

Troubleshooting

What is a healthy unit?

In order to troubleshoot the DVC2000 series digital valve controller, it is critical to understand how a healthy unit is supposed to behave. Below is a list of behaviors you should see if the instrument is performing well.

- LCD correctly displaying characters
- Pushbuttons allow navigation
- Valve travels full stroke
- No diagnostics messages
- No alerts or alarms
- Hall sensor within the valid range of travel on the magnet array
- Slight audible air venting
- Minimal overshoot
- Quick response
- Functionality matches the tier level

What are the observable symptoms?

The next thing to do is to identify the symptoms of the unhealthy unit. Are there any obvious discrepancies that can be identified? Work through the following items to help gather information about the faulty behavior and identify the core problem(s).

1. Check the relay pressure range.

There are two available relays for the DVC2000:

- Low pressure: 0–3.4 bar (0–49 psi) — white label
- High pressure: 3.5–7 bar (50–100 psi) — green label

The supply pressure feeding the instrument must fall within the rated pressure range of the installed relay for proper operation.

2. Check the instrument protection (LCD via pushbuttons and Configure/Calibrate via HART)
3. Check for local device diagnostic messages
4. Check the alerts via HART
5. Check the feedback setup

Is the pole piece on the DVC2000 housing within the valid travel range of the feedback array?

6. Observe the stem movement and pressure delivery

Determine the logical causes.

With the discrepancies identified, logic can now be applied to isolate the component that is in need of repair or replacement. There are seven main categories of problems:

1. Wiring and Terminations
2. Air Supply
3. Electronics
4. Firmware
5. Pneumatics
6. Travel feedback
7. Mounting

Repair or replace the faulty components.

By isolating the problem to one of these categories, component replacement or repair becomes simple and straightforward. Refer to section 5 for component replacement instructions.

B

Checking Voltage Available



Personal injury or property damage caused by fire or explosion may occur if this test is attempted in any area which contains a potentially explosive atmosphere or has been classified as hazardous.

To check the Voltage Available at the instrument, perform the following:

1. Disconnect the field wiring from the control system and connect equipment as shown in figure B-2 to the control system terminals.”

DVC2000 Series

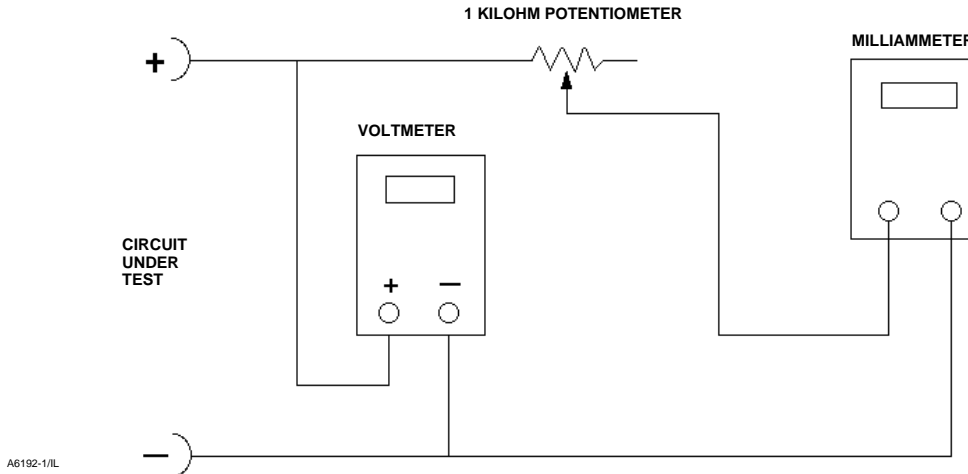

Figure B-2. Voltage Test Schematic

2. Set the control system to provide maximum output current.
3. Set the resistance of the 1 kilOhm potentiometer shown in figure B-2 to zero.
4. Record the current shown on the milliammeter.
5. Adjust the resistance of the 1 kilOhm potentiometer until the voltage read on the voltmeter is 9.0 Volts.
6. Record the current shown on the milliammeter.
7. If the current recorded in step 6 is the same as that recorded in step 4 (± 0.08 mA), the voltage available is adequate.

B

Travel shows the value of the DVC2000 Series digital valve controller travel in % (percent) of ranged travel. Travel always represents how far the valve is open.

Valve SP shows the requested valve position in % of ranged travel.

Drive Sgl shows the value of the instrument drive signal in % (percent) of maximum drive.

Pressure shows the value of the instrument output pressure in psi, bar, or kPa.

Additional Instrument Variables



Viewing Variables



Note

These variables are not available for instrument level AC.



Note

These variables are not available for instrument level AC.

Analog Input, Travel, Valve Set Point, Drive Signal and Output Pressure

The following variables are displayed on the Online menu:

Analog In shows the value of the instrument analog input in mA (milliamperes) or % (percent) of ranged input.

The *Variables* menu is available to view additional variables, such as the status of the auxiliary input, the instrument internal temperature, cycle count, travel accumulation and device free time. To view one of these variables, from the *Online* menu select *Setup & Diag, Display, and Variables*. If a value for a variable does not appear on the display, select the variable and a detailed display of that variable with its value will appear. A variable's value does not appear on the menu if the value becomes too large to fit in the allocated space on the display, or if the variable requires special processing, such as Free Time.

Principle of Operation

- *Temp*—The internal temperature of the instrument is displayed in either degrees Fahrenheit or Celsius.

- *Cycl Count*—Cycle Counter displays the number of times the valve travel has cycled. Only changes in direction of the travel after the travel has exceeded the deadband are counted as a cycle. Once a new cycle has occurred, a new deadband around the last travel is set. The value of the Cycle Counter can be reset from the *Cycle Count Alert* menu.

- *Tvl Acum*—Travel Accumulator contains the total change in travel, in percent of ranged travel. The accumulator only increments when travel exceeds the deadband. Then the greatest amount of change in one direction from the original reference point (after the deadband has been exceeded) will be added to the Travel Accumulator. The value of the Travel Accumulator can be reset from the *Travel Accum Alert* menu.

- *Free Time*—Free Time is the percent of time that the firmware is idle. A typical value is 25%. The actual value depends on the number of functions in the instrument that are enabled and also on the amount of communication currently in progress.

Viewing Device Information



The *Device Information* menu is available to view information about the instrument. From the *Online* menu, select *Setup & Diag*, *Display*, and *Device Information*. Follow the prompts on the Field Communicator display to view information in the following fields: *HART Univ Rev* (HART Universal Revision), *Device Rev* (Device Revision), *Firmware Rev* (Firmware Revision), *Hardware Rev* (Hardware Revision), *Inst Level* (Instrument Level), and *Device ID*.

- *HART Univ Rev*—HART Universal Revision is the revision number of the HART Universal Commands which are used as the communications protocol for the instrument.

- *Device Rev*—Device Revision is the revision number of the software for communication between the Field Communicator and the instrument.

- *Firmware Rev*—Firmware Revision is the revision number of the Fisher firmware in the instrument.

Table B-1. Functions Available for Instrument Level

Instrument Level	Functions Available
AC	Communicates via the LCD or with Model 375 Field Communicator. Provides basic setup and calibration.
HC	Communicates via the LCD, the Model 375 Field Communicator and AMS ValveLink Software. Provides basic setup, calibration, travel cutoffs and limits, minimum opening and closing times, input characterization (linear, equal percentage, quick opening, and custom) and the following alerts: travel deviation; travel alert high, low, high high, and low low; drive signal; auxiliary terminal; cycle counter; and travel accumulation.
AD	Includes all functions listed above plus (with ValveLink software) all offline diagnostic tests (dynamic error band, drive signal, step response, and valve signature) plus online trending
PD	Includes all functions listed above plus online valve signature test (friction analysis)

- *Hardware Rev*—Hardware Revision is the revision number of the electrical circuitry within the instrument printed wiring board.

- *Inst Level*—Indicates the instrument level
AC—Auto Calibrate
HC—HART Communicating
AD—Advanced Diagnostics
PD—Performance Diagnostics

Table B-1 lists the functions available for each instrument level.

- *Device ID*—Each instrument has a unique Device Identifier. The device ID provides additional security to prevent this instrument from accepting commands meant for other instruments.

B

Viewing Instrument Status



Note

Instrument Status is not available for instrument level AC.

To view the instrument status, from the *Online* menu select *Instrument Status*. The following describes the various displays for the Instrument Status menu.

- *Done*—Select this when you are done viewing the instrument status.



Note

Alerts are not available with instrument level AC.

● **Valve Alerts**—If a valve alert is active, it will appear when the Valve Alerts menu item is selected. If more than one alert is active, they will appear on the display one at a time in the order listed below.

1. Alert Record has Entries
2. Alert Record is full
3. Instrument Time is Invalid
4. Tvl Accumulation Alert
5. Cycle Counter Alert
6. Non-critical NVM Alert
7. Power Starvation Alert
8. Drive Signal Alert
9. Tvl Lim/Cutoff Low
10. Tvl Lim/Cutoff High
11. Tvl Deviation Alrt
12. Tvl Alert Hi Hi
13. Tvl Alert Hi
14. Tvl Alert Lo Lo
15. Tvl Alert Lo

B

● **Failure Alerts**—If a self-test failure has occurred, it will appear when the Failure Alerts menu item is selected. If there are multiple failures, they will appear on the display one at a time in the order listed below.

1. *Offline/Failed*—This failure indicates a failure, enabled from the Self Test Shutdown menu, caused an instrument shutdown. Press Enter to see which of the specific failures caused the Offline/Failed indication.

2. *Travel Sensor Fail*—This failure indicates the sensed travel is outside the range of -25.0 to 125.0% of calibrated travel. If this failure is indicated, check the instrument mounting.

3. *Pressure Sensor Fail*—This failure indicates the actuator pressure is outside the range of -24.0 to 125.0% of the calibrated pressure for more than 60 seconds. If this failure is indicated, check the instrument supply pressure. If the failure persists, ensure the printed wiring board assembly is properly mounted onto the mounting frame, and the pressure sensor O-rings are properly installed. If the failure does not clear after restarting the instrument, replace the printed wiring board assembly.

4. *Temperature Sensor Fail*—This failure is indicated when the instrument temperature sensor fails, or the sensor reading is outside of the range of -40 to 85°C (-40 to 185°F). The temperature reading is used internally for temperature compensation of inputs. If this failure is indicated, restart the instrument and see if it clears. If it does not clear, replace the printed wiring board assembly.

5. *Critical NVM Fail*—This failure is indicated when the Non-Volatile Memory integrity test fails. Configuration data is stored in NVM. If this failure is indicated, restart the instrument and see if it clears. If it does not clear, replace the printed wiring board Assembly.

6. *Drive Current Fail*—This failure is indicated when the drive current does not read as expected. If this failure occurs, check the connection between the I/P converter and the printed wiring board assembly. Try removing the I/P converter and re-installing it. If the failure does not clear, replace the I/P converter or the printed wiring board assembly.

Principle of Operation

Table B-2. Alerts Included in Alert Groups for Alert Record

Alert Group	Alerts Include in Group
Valve Alerts	Travel Alert Lo Travel Alert Hi Travel Alert Lo Lo Travel Alert Hi Hi Travel deviation Drive signal
Failure Alerts	No free time Flash ROM fail Drive current fail Ref Voltage fail NVM fail Temperature sensor fail Pressure sensor fail Travel sensor fail

7. *Ref Voltage Fail*—This failure is indicated whenever there is a failure associated with the internal voltage reference. If this failure is indicated, restart the instrument and see if it clears. If it does not clear, replace the printed wiring board assembly.

8. *No Free Time*—This failure is indicated if the instrument is unable to complete all of the configured tasks. This will not occur with a properly functioning instrument.

9. *Flash ROM Fail*—This failure indicates the Read Only Memory integrity test failed. If this failure is indicated, restart the instrument and see if it clears. If

it does not clear, replace the printed wiring board assembly.

● **Alert Record**—The instrument contains an alert record that can store up to 20 alerts from any of the enabled alert groups: Valve Alerts or Failure Alerts. See the Advanced Setup section for information on enabling alert groups. Table B-2 lists the alerts included in each of the groups. The alert record also includes the date and time (from the instrument clock) the alerts occurred.

● **Operational Status**—This menu item indicates the status of the Operational items listed below. The status of more than one operational may be indicated. If more than one Operational status is set, they will appear on the display one at a time in the order listed below.

1. Out of Service
2. Auto Calibration in Progress
3. Input Char Selected
4. Custom Char Selected
5. Diagnostic in Progress
6. Calibration in Progress
7. Set Point Filter Active

Appendix C Model 375 Field Communicator Basics

Display	C-2
Using the Keypad	C-2
On/Off Key	C-2
Navigation Keys	C-2
Enter Key	C-2
Tab Key	C-2
Alphanumeric Keys	C-2
Backlight Adjustment Key	C-4
Function Key	C-3
Multifunction LED	C-3
Using the Touch Screen	C-3
Using the Soft Input Panel Keyboard	C-2
Menu Structure	C-4
Offline Operation	C-4
Saving Setup and Calibration Data	C-4
Polling	C-5
System Information	C-5
Reviewing Instrument Device Descriptions	C-5
Simulation	C-5
Online Operation	C-6
Displaying the Field Communicator Device Description Revision	C-6



DVC2000 Series



Figure C-1. Model 375 Field Communicator



Note

The Model 375 Field Communicator device description revision (DD) determines how the Field Communicator interfaces with the instrument. For information on displaying the device description revision, see page C-6.

This section discusses the display, keypad, and menu structure for the Field Communicator, shown in figure C-1. It includes information for displaying the Field Communicator device description revision number. For information on connecting the Field Communicator to the instrument, see the Installation section, Section 2. For more information on the Field Communicator, such as specifications and servicing, see the User's Manual for the Field Communicator 00375-0047-0001, included with the Field Communicator. This manual also is available from Rosemount Inc., Measurement Division.

Display

The Field Communicator communicates information to you through a 1/4 VGA (240 by 320 pixels) monochrome touch screen. It has a viewing area of approximately 9 cm by 12 cm.

Using the Keypad

On/Off Key

The on/off key is used to turn the Field Communicator on and off.

From the Main Menu, select HART Application to run the HART application. On startup, the HART Application automatically polls for devices.

If a HART-compatible device is found, the Field Communicator displays the Online menu. For more information on Online and Offline operation, see Menu Structure in this section.

The on/off key is disabled while any applications are open, making it necessary for you to exit the 375 Main Menu before using the on/off key. This feature helps to avoid situations where the Field Communicator could be unintentionally turned off while a device's output is fixed or when configuration data has not been sent to a device.

Navigation Keys

Four arrow navigation keys allow you to move through the menu structure of the application. Press the right arrow () navigation key to navigate further into the menu.

Enter Key

The enter key allows you perform the highlighted item, or to complete an editing action. For example, if you highlight the Cancel button, and then push the enter key, you will cancel out of that particular window. The enter key does not navigate you through the menu structure.

Tab Key

The tab key allows you to move between selectable controls.

Alphanumeric Keys

Figure C-2 shows the alphanumeric keypad. Data entry, and other options, using letters, number and

Model 375 Field Communicator Basics



Figure C-2. Model 375 Field Communicator Alphanumeric and Shift Keys

other characters can be performed using this keypad. The 375 Field Communicator will automatically determine the mode depending upon the input necessary for the particular field.

To enter text when in alphanumeric mode, press the desired keypad button in quick repetition to scroll through the options to attain the appropriate letter or number.

For example, to enter the letter “Z”, press the 9 key quickly four times.

The alphanumeric keys are also used for the Fast Key sequence. The Fast Key sequence is a sequence of numerical button presses, corresponding to the menu options that lead you to a given task.

Backlight Adjustment Key



The backlight adjustment key has four settings allowing you to adjust the intensity of the display. Higher intensities will shorten the battery life.

Function Key



The function key allows you to enable the alternate functionality of select keys. The grey characters on the keys indicate the alternate functionality. When enabled, the orange multifunction LED light will appear and an indication button can be found on the soft input panel (SIP). Press the key again to disable the function key.

Multifunction LED

The multifunction LED indicates when the 375 Field Communicator is in various states. Green signifies that

the Field Communicator is on, while flashing green indicates that it is in power saving mode. Green and orange indicate that the function key is enabled, and a green and orange flash indicates that the on/off button has been pressed long enough for the Field Communicator to power up.

Using the Touch Screen

The touch screen display allows you to select and enter text by touching the window.

Tap the window once to select a menu item or to activate a control. Double-tap to access the various options associated with the menu item.

CAUTION

The touch screen should be contacted by blunt items only. The preferred item is the stylus that is included with the 375 Field Communicator. The use of a sharp instrument can cause damage to the touch screen interface.

Use the back arrow button(←) to return to the previous menu. Use the terminate key (ⓧ) in the upper right corner of the touch screen to end the application.

C

Using the Soft Input Panel (SIP) Keyboard

As you move between menus, different dynamic buttons appear on the display. For example, in menus providing access to on-line help, the HELP button may appear on the display. In menus providing access to the Home menu, the HOME button may appear on the display. In many cases the SEND label appears indicating that you must select the button on the display to send the information you have entered on the keypad to the FIELDVUE instrument's memory. Online menu options include:

DVC2000 Series

- **Hot Key** 

Tap the Hot Key from any Online window to display the Hot Key menu. This menu allows you to quickly:

- Change the instrument mode
- Change the control mode
- Change the instrument protection
- Change tuning to improve response

The Hot Key can also be accessed by enabling the function key, and pressing the 3 key on the alphanumeric key pad.

For details on instrument mode, control mode, protection, tuning sets, and other configuration parameters, see the Advanced Setup and Calibration section, Section 4.

- **SCRATCHPAD**  is a text editor that allows you to create, open, edit and save simple text (.txt) documents.
- **HELP**—gives you information regarding the display selection.
- **SEND**—sends the information you have entered to the instrument.
- **HOME**—takes you back to the Online menu.
- **EXIT**—takes you back to the menu from which you had requested the value of a variable that can only be read.
- **ABORT**—cancels your entry and takes you back to the menu from which you had selected the current variable or routine. Values are not changed.
- **OK**—takes you to the next menu or instruction screen.
- **ENTER**—sends the information you have selected to the instrument or flags the value that is to be sent to the instrument. If it is flagged to be sent, the SEND dynamic label appears as a function key selection.
- **ESC**—cancels your entry and takes you back to the menu from which you had selected the current variable or routine. Values are not changed.
- **SAVE**—saves information to the internal flash or the configuration expansion module.

Menu Structure

The Field Communicator is generally used in two environments: offline (when not connected to an instrument) and online (connected to an instrument).

Offline Operation

Selecting HART Application when not connected to a FIELDVUE instrument causes the Field Communicator to display the message “No device found at address 0. Poll?” Selecting “Yes” or “No” will bring you to the HART Application menu. Three choices are available from this screen: *Offline*, *Online* and *Utility*. The Offline menu allows you to create offline configurations, as well as view and change device configurations stored on the 375 Field Communicator. The Utility menu allows you to set the polling option, change the number of ignored status messages, view the available Device Descriptions, perform a simulation, and view HART diagnostics.

Saving Setup and Calibration Data

You can upload setup and calibration data from the DVC2000 Series digital valve controller and save it in the Field Communicator Internal Flash or a Configuration Expansion Module. From the *Offline* menu you can then download this data to multiple devices so that they all contain the same setup and calibration data. You can also edit the saved data.

You upload setup and calibration data from the *Online* menu. This requires that the Field Communicator be connected to a digital valve controller powered by a 4 to 20 mA source. To save data from any *Online* menu select the SAVE key. Follow the prompts on the Field Communicator to save the data to the Internal Flash or the Configuration EM and name the saved data. Once the data is saved, the SAVE key disappears until you change the data in the instrument.

Downloading the saved data requires that you first mark the configurable variables you wish to download (the default is all variables unmarked). To do this, from the *Offline* menu select *Saved Configuration*. Depending on the location of the saved data, select either *Internal Flash Contents* or *Configuration EM Contents*. Select the name for the saved data. From the *Saved Configuration* menu select *Edit*.

From the *Edit* menu you can mark all configurable variables for download, unmark all configurable variables so none are downloaded, edit each variable individually, or save your configuration to the internal flash or the optional configuration expansion module. The following briefly describes each item on the menu. For more information, see the User’s Manual for the 375 Field Communicator – 00375-0047-001.

- **Mark All**—flags all configurable variables to be sent to a HART-compatible device. Configurable

Model 375 Field Communicator Basics

variables are those that appear when you edit variables in the configuration using the *Edit Individually* option.

- *Unmark All*—removes flags from all configurable variables in the configuration. Unmarked configurable variables are not sent to a connected HART-compatible device.

- *Edit Individually*—opens the Edit Individually menu to permit editing configurable variables in the saved data. For information on editing configurable variables, refer to the Field Communicator product manual.

- *Save As...*—saves your new configuration to the Internal Flash, or the Configuration EM. For more information on the Save As option, see the Field Communicator product manual.

Once the configurable variables are marked for download, return to the Saved Configuration menu and select *Save*. Follow the prompts on the Field Communicator to download the saved data to the instrument.

Polling

When several devices are connected in the same loop, such as for split ranging, each device must be assigned a unique polling address. Use the Polling options to configure the Field Communicator to automatically search for all or specific connected devices.

To enter a polling option, select *Utility* from the HART Application menu. Select *Configure HART Application*, and then select *Polling*. Tap ENTER to select the highlighted option.

The Polling options are:

1. **Never Poll**—connects to a device at address 0, and if not found will not poll for devices at addresses 1 through 15.
2. **Ask Before Polling**—connects to a device at address 0, and if not found asks if you want to poll for devices at addresses 1 through 15.
3. **Always Poll**—connects to a device at address 0, and if not found will automatically poll for devices at addresses 1 through 15.
4. **Digital Poll**—automatically polls for devices at address 0 through 15 and lists devices found by tag.
5. **Poll Using Tag**—asks for a device HART tag and then polls for that device.
6. **Poll Using Long Tag**—allows you to enter the long tag of the device. (Only supported in HART Universal revision 6 devices.)

To find individual device addresses, use the Digital Poll option to find each connected device in the loop and list them by tag.

For more information on setting the polling address, see the Advanced Setup and Calibration section, Section 4.

System Information

To access the Field Communicator system information, select *Settings* from the 375 Main Menu.

About 375 includes software information about your 375 Field Communicator.

Licensing can be viewed when you turn on the 375 Field Communicator and in the License settings menu. The license setting allows you to view the license on the System Card.

Memory settings consists of System Card, Internal Flash size, and Ram size, as well as the Expansion Module if installed. It allows you to view the total memory storage and available free space.

Reviewing Instrument Device Descriptions

The Field Communicator memory module contains device descriptions for specific HART-compatible devices. These descriptions make up the application software that the communicator needs to recognize particular devices.

To review the device descriptions programmed into your Field Communicator, select *Utility* from the HART Application menu, then select *Available Device Descriptions*. The manufacturers with device descriptions installed on the Field Communicator are listed.

Select the desired manufacturer to see the list of the currently installed device models, or types, provided by the selected manufacturer.

Select the desired instrument model or type to see the available device revisions that support that instrument.

Simulation

The Field Communicator provides a simulation mode that allows you to simulate an online connection to a HART-compatible device. The simulation mode is a training tool that enables you to become familiar with the various menus associated with a device without having the Field Communicator connected to the device.

To simulate an online connection, select *Utility* from the main menu. Select *Simulation* then select *Fisher Controls*. Select *DVC2000* to see the menu structure for the DVC2000 Series digital valve controller. Refer to the appropriate sections of this manual for information on the various menus.

C

DVC2000 Series

Online Operation

The Online menu is the first to be displayed when connecting to a HART compatible device. It contains important information about the connected device.

Displaying the Field Communicator Device Description Revision

Device Description (DD) Revision is the revision number of the Fisher Device Description that resides in the Field Communicator. It defines how the Field Communicator is to interact with the user and instrument.

Field Communicators with device description revision 1 are used with DVC2000 Series instruments with firmware revision 2. You can display the device description revision when the Field Communicator is Offline or Online:

Offline—To see the Field Communicator device description revision number, from the main menu, select *Utility, Simulation, Fisher Controls,* and *DVC2000.*

Online—To see the Field Communicator device description revision number, connect the Field Communicator to an instrument connected to a source supplying a 4 to 20 mA signal. From the *Online* menu, select *Setup & Diag, Display, 375 DD Rev.*

Loop Schematics/Nameplates

Appendix D Loop Schematics/Nameplates

This section includes loop schematics required for wiring of intrinsically safe installations. It also contains the approvals nameplates. If you have any questions, contact your Fisher sales office.

- 1 EQUIPMENT SHALL BE INSTALLED IN ACCORDANCE WITH THE CANADIAN ELECTRICAL CODE (CEC) PART I.
- 2 BARRIERS MUST BE CSA APPROVED WITH ENTITY PARAMETERS AND ARE TO BE INSTALLED IN ACCORDANCE WITH THE MANUFACTURER'S IS INSTALLATION INSTRUCTIONS.
- 3 THE ENTITY CONCEPT ALLOWS INTERCONNECTION OF INTRINSICALLY SAFE APPARATUS TO ASSOCIATED APPARATUS, NOT SPECIFICALLY EXAMINED IN SUCH COMBINATION. THE CRITERIA FOR INTERCONNECTION IS THAT THE VOLTAGE (V_{max}) AND THE CURRENT (I_{max}) OF THE INTRINSICALLY SAFE APPARATUS MUST BE EQUAL TO OR GREATER THAN THE VOLTAGE (V_{oc}) AND CURRENT (I_{sc}) DEFINED BY THE ASSOCIATED APPARATUS. IN ADDITION, THE SUM OF THE MAXIMUM UNPROTECTED CAPACITANCE (C_i) AND INDUCTANCE (L_i) OF EACH INTRINSICALLY SAFE APPARATUS, AND THE INTERCONNECTING WIRING, MUST BE LESS THAN THE ALLOWABLE CAPACITANCE (C_o) AND INDUCTANCE (L_o) DEFINED BY THE ASSOCIATED APPARATUS. IF THESE CRITERIA ARE MET, THEN THE COMBINATION MAY BE CONNECTED.
 FORMULAS - $V_{max} > V_{oc}$, $I_{max} > I_{sc}$, $C_i + C_{cable} < C_o$, $L_i + L_{cable} < L_o$

4 ENTITY PARAMETERS FOR EACH IS CIRCUIT ARE AS FOLLOWS:

CIRCUIT	V_{max} (V)	I_{max} (A)	C_i	L_i	P_{max}
XMTR	28Vdc	100mA	5nF	0mH	1W
MAIN	30Vdc	130mA	5nF	0.55mH	1W
LS1	16Vdc	76mA	5nF	0mH	1W
LS2	16Vdc	76mA	5nF	0mH	1W

5 WHERE MULTIPLE IS CIRCUITS ARE USED:

- EACH IS CIRCUIT MUST USE SHIELDED TWISTED PAIR CABLE.
- IS CIRCUITS MUST ENTER ENCLOSURE VIA CONDUIT ENTRIES AS SPECIFIED IN DETAIL 1.
- CABLE INSULATION AND SHIELD MUST EXTEND TO WITHIN PARTITIONED AREA (SEE DETAIL 1).
- XMTR, LS1, AND LS2 CIRCUITS ARE OPTIONAL.

6 IF HAND-HELD COMMUNICATOR OR MULTIPLEXER IS USED, IT MUST BE CSA CERTIFIED WITH ENTITY PARAMETERS AND INSTALLED PER THE MANUFACTURER'S CONTROL DRAWING.

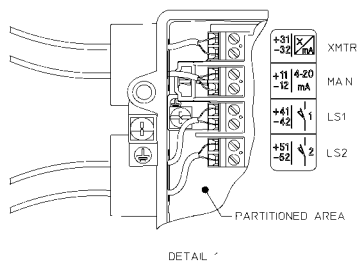
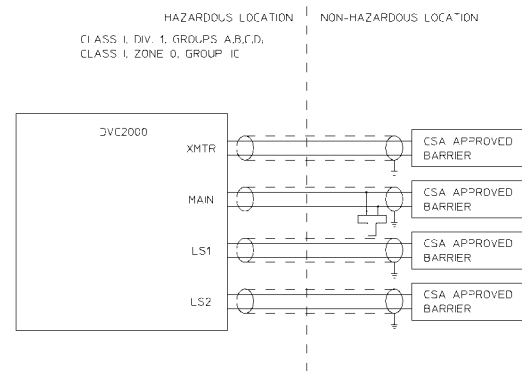

GE12444

Figure A-1. CSA Loop Schematic

D

DVC2000 Series

1. INSTALLATION MUST BE IN ACCORDANCE WITH THE NATIONAL ELECTRICAL CODE (NEC) AND ANSI/ISA RP12.6.
2. BARRIERS MUST BE CONNECTED PER MANUFACTURER'S INSTALLATION INSTRUCTIONS.
3. THE ENTITY CONCEPT ALLOWS INTERCONNECTION OF INTRINSICALLY SAFE APPARATUS TO ASSOCIATED APPARATUS, NOT SPECIFICALLY EXAMINED IN SUCH COMBINATION. THE CRITERIA FOR INTERCONNECTION IS THAT THE VOLTAGE (V_{max}) AND THE CURRENT (I_{max}) OF THE INTRINSICALLY SAFE APPARATUS MUST BE EQUAL TO OR GREATER THAN THE VOLTAGE (V_{oc}) AND CURRENT (I_{sc}) DEFINED BY THE ASSOCIATED APPARATUS. IN ADDITION, THE SUM OF THE MAXIMUM UNPROTECTED CAPACITANCE (C_i) AND INDUCTANCE (L_i) OF EACH INTRINSICALLY SAFE APPARATUS, AND THE INTERCONNECTING WIRING, MUST BE LESS THAN THE ALLOWABLE CAPACITANCE (C_o) AND INDUCTANCE (L_o) DEFINED BY THE ASSOCIATED APPARATUS. IF THESE CRITERIA ARE MET, THEN THE COMBINATION MAY BE CONNECTED.
 FORMULAS: $V_{max} > V_{oc}$ or $V_i + C_{cable} < C_o$, $I_i > I_{sc}$ or $I_i + L_{cable} < L_o$
4. ENTITY PARAMETERS FOR EACH I.S. CIRCUIT ARE AS FOLLOWS:

CIRCUIT	V_{max} (V)	I_{max} (I)	C_i	L_i	P_{max}
XMTR	28Vdc	100mA	5nF	0mH	1W
MAIN	30Vdc	130mA	5nF	0.55mH	1W
LS1	16Vdc	76mA	5nF	0mH	1W
LS2	16Vdc	76mA	5nF	0mH	1W
5. WHERE MULTIPLE I.S. CIRCUITS ARE USED:
 - EACH I.S. CIRCUIT MUST USE SHIELDED TWISTED PAIR CABLE.
 - I.S. CIRCUITS MUST ENTER ENCLOSURE VIA CONDUIT ENTRIES AS SPECIFIED IN DETAIL 1.
 - CABLE INSULATION AND SHIELD MUST EXTEND TO WITHIN PARTITIONED AREA (SEE DETAIL 1).
 - XMTR, LS1, AND LS2 CIRCUITS ARE OPTIONAL.
6. CLASS I, DIV 2 APPLICATIONS MUST BE INSTALLED AS SPECIFIED IN NEC ARTICLE 501-4(B). EQUIPMENT AND FIELD WIRING IS NON-INCENDIVE WHEN CONNECTED TO APPROVED BARRIERS WITH ENTITY PARAMETERS.
7. MAXIMUM SAFE AREA VOLTAGE SHOULD NOT EXCEED 250 Vrms.
8. RESISTANCE BETWEEN BARRIER GROUND AND EARTH GROUND MUST BE LESS THAN ONE OHM.
9. IF HAND-HELD COMMUNICATOR OR MULTIPLEXER IS USED, IT MUST BE FM APPROVED WITH ENTITY PARAMETERS AND INSTALLED PER THE MANUFACTURER'S CONTROL DRAWING.

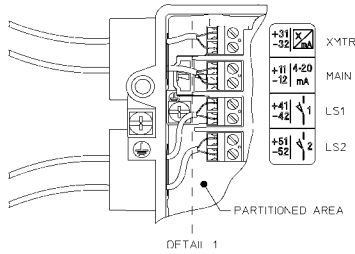
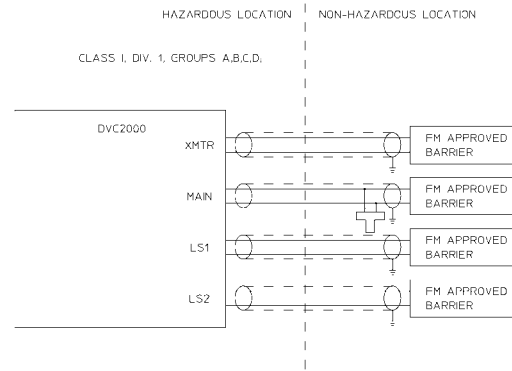

GE10683

Figure A-2. FM Loop Schematic

TYPE DVC2000

FISHER[®]

SN

MAX CURRENT: 30mA --- MAX VOLTAGE: 30VDC ---
 MAX SUPPLY: 100psi --- AMBIENT TEMP: -40°..80°C

FISHER CONTROLS INTL LLC
 MARSHALLTOWN, IOWA, USA
 MFG LOCATION:

CSA
 CL I DIV 2 GP ABCD T5
 Ex ia INTRINSICALLY SAFE
 CL I DIV 1 GP ABCD PER DWG GE12444
 Ex ia IIC T4(Tamb ≤ 80°C), T5(Tamb ≤ 40°C)
 PER DWG GE12444

FM
 NI: CL 1 DIV 2 GP ABCD T5
 IS: CL 1 DIV 1 GP ABCD PER DWG GE10683

WARNING:
 SUBSTITUTION OF COMPONENTS MAY IMPAIR INTRINSIC SAFETY AND/OR SUITABILITY FOR DIVISION 2.
 DO NOT DISCONNECT EQUIPMENT UNLESS POWER HAS BEEN SWITCHED OFF.

REFER TO MANUAL FOR ADDITIONAL WARNINGS AND LIMITS GE13850

Figure A-3. CSA and FM Approvals Nameplate; Intrinsically Safe, Class I Division 2, Zone 0

Loop Schematics/Nameplates

1 INSTALLATION MUST BE IN ACCORDANCE WITH THE NATIONAL WIRING PRACTICES OF THE COUNTRY IN USE.

2 BARRIERS MUST BE CONNECTED PER MANUFACTURER'S INSTALLATION INSTRUCTIONS.

3 INTRINSICALLY SAFE APPARATUS MAY BE CONNECTED TO ASSOCIATED APPARATUS NOT SPECIFICALLY EXAMINED IN SUCH COMBINATION. THE CRITERIA FOR INTERCONNECTION IS THAT THE VOLTAGE (U) AND THE CURRENT (I) OF THE INTRINSICALLY SAFE APPARATUS MUST BE EQUAL TO OR GREATER THAN THE VOLTAGE (U₀) AND CURRENT (I₀) DEFINED BY THE ASSOCIATED APPARATUS. IN ADDITION, THE SUM OF THE MAXIMUM UNPROTECTED CAPACITANCE (C) AND INDUCTANCE (L) OF EACH INTRINSICALLY SAFE APPARATUS, AND THE INTERCONNECTING WIRING, MUST BE LESS THAN THE ALLOWABLE CAPACITANCE (C₀) AND INDUCTANCE (L₀) DEFINED BY THE ASSOCIATED APPARATUS. IF THESE CRITERIA ARE MET, THEN THE COMBINATION MAY BE CONNECTED.

FORMULAS

$$U_i > U_0$$

$$I_i > I_0$$

$$C_i + C_{cable} < C_0$$

$$L_i + L_{cable} < L_0$$

$$P_i > P_0$$

4 ENTITY PARAMETERS FOR EACH I.S. CIRCUIT ARE AS FOLLOWS:

CIRCUIT	U _i	I _i	C _i	L _i	P _i
XMTR	28Vdc	100mA	5nF	0mH	1W
MAIN	30Vdc	130mA	5nF	0.55mH	1W
LS1	16Vdc	76mA	5nF	0mH	1W
LS2	16Vdc	76mA	5nF	0mH	1W

5 WHERE MULTIPLE I.S. CIRCUITS ARE USED:

- EACH I.S. CIRCUIT MUST USE SHIELDED TWISTED PAIR CABLE.
- I.S. CIRCUITS MUST ENTER ENCLOSURE VIA CONDUIT ENTRIES AS SPECIFIED IN DETAIL 1.
- CABLE INSULATION AND SHIELD MUST EXTEND TO WITHIN PARTITIONED AREA (SEE DETAIL 1).
- XMTR, LS1, AND LS2 CIRCUITS ARE OPTIONAL.

6 RESISTANCE BETWEEN BARRIER GROUND AND EARTH GROUND MUST BE LESS THAN ONE OHM.

7 IF HAND-HELD COMMUNICATOR OR MULTIPLEXER IS USED, IT MUST BE APPROVED WITH ENTITY PARAMETERS AND INSTALLED PER THE MANUFACTURER'S CONTROL DRAWING.

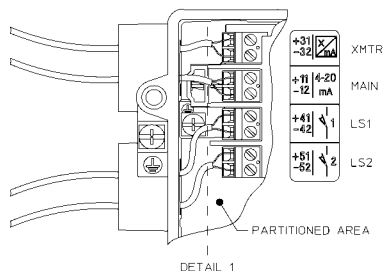
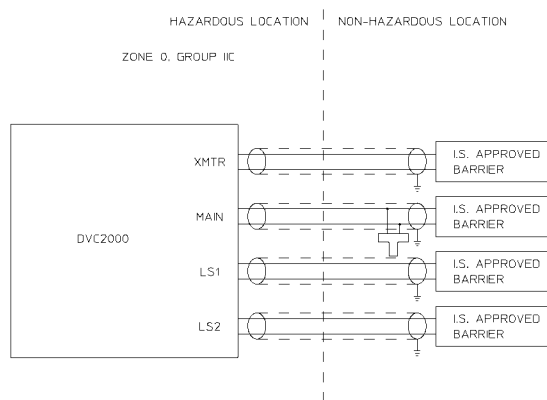

GE14685

Figure A-4. ATEX (LCIE) Loop Schematic

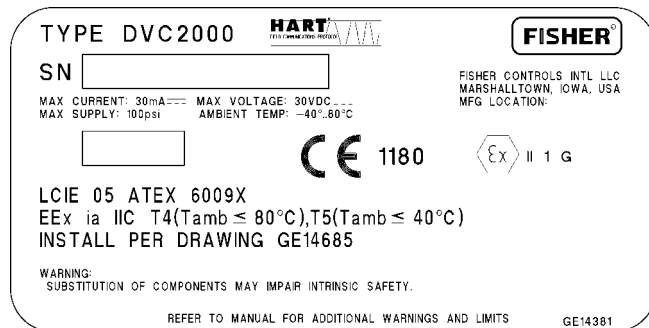

SPECIAL CONDITIONS FOR SAFE USE:
 •THE EQUIPMENT IS AN INTRINSICALLY SAFE EQUIPMENT. IT CAN BE MOUNTED IN A HAZARDOUS AREA.
 •THE TERMINAL BLOCKS CAN BE ONLY CONNECTED TO CERTIFIED INTRINSICALLY SAFE EQUIPMENTS AND
 •THESE COMBINATIONS MUST BE COMPATIBLE AS REGARD INTRINSIC SAFETY RULES.
 •THE EQUIPMENT SHALL BE CONNECTED IN ACCORDANCE WITH THE MANUFACTURE'S INSTALLATION INSTRUCTIONS (SEE DRAWING GE14685)

TEMPERATURE CLASSIFICATION:
 T4 at Ta ≤ 80 °C
 T5 at Ta ≤ 40 °C

Figure A-5. ATEX (LCIE) Nameplate; Intrinsically Safe

D

DVC2000 Series

- 1 INSTALLATION MUST BE IN ACCORDANCE WITH THE NATIONAL WIRING PRACTICES OF THE COUNTRY IN USE.
- 2 BARRIERS MUST BE CONNECTED PER MANUFACTURER'S INSTALLATION INSTRUCTIONS.
- 3 INTRINSICALLY SAFE APPARATUS MAY BE CONNECTED TO ASSOCIATED APPARATUS NOT SPECIFICALLY EXAMINED IN SUCH COMBINATION. THE CRITERIA FOR INTERCONNECTION IS THAT THE VOLTAGE (U_i) AND THE CURRENT (I_i) OF THE INTRINSICALLY SAFE APPARATUS MUST BE EQUAL TO OR GREATER THAN THE VOLTAGE (U_o) AND CURRENT (I_o) DEFINED BY THE ASSOCIATED APPARATUS. IN ADDITION, THE SUM OF THE MAXIMUM UNPROTECTED CAPACITANCE (C_i) AND INDUCTANCE (L_i) OF EACH INTRINSICALLY SAFE APPARATUS, AND THE INTERCONNECTING WIRING, MUST BE LESS THAN THE ALLOWABLE CAPACITANCE (C_o) AND INDUCTANCE (L_o) DEFINED BY THE ASSOCIATED APPARATUS. IF THESE CRITERIA ARE MET, THEN THE COMBINATION MAY BE CONNECTED.
 FORMULAS
 $U_i > U_o$
 $I_i > I_o$
 $C_i + C_{cable} < C_o$
 $L_i + L_{cable} < L_o$
 $P_i > P_o$
- 4 ENTITY PARAMETERS FOR EACH I.S. CIRCUIT ARE AS FOLLOWS:

CIRCUIT	U_i	I_i	C_i	L_i	P_i
XMTR	28Vdc	100mA	5nF	0mH	1W
MAIN	30Vdc	130mA	5nF	0.55mH	1W
LS1	16Vdc	76mA	5nF	0mH	1W
LS2	16Vdc	76mA	5nF	0mH	1W
- 5 WHERE MULTIPLE I.S. CIRCUITS ARE USED:
 - EACH I.S. CIRCUIT MUST USE SHIELDED TWISTED PAIR CABLE.
 - I.S. CIRCUITS MUST ENTER ENCLOSURE VIA CONDUIT ENTRIES AS SPECIFIED IN DETAIL 1.
 - CABLE INSULATION AND SHIELD MUST EXTEND TO WITHIN PARTITIONED AREA (SEE DETAIL 1).
 - XMTR, LS1, AND LS2 CIRCUITS ARE OPTIONAL.
- 6 RESISTANCE BETWEEN BARRIER GROUND AND EARTH GROUND MUST BE LESS THAN ONE OHM.
- 7 IF HAND-HELD COMMUNICATOR OR MULTIPLEXER IS USED, IT MUST BE APPROVED WITH ENTITY PARAMETERS AND INSTALLED PER THE MANUFACTURER'S CONTROL DRAWING.

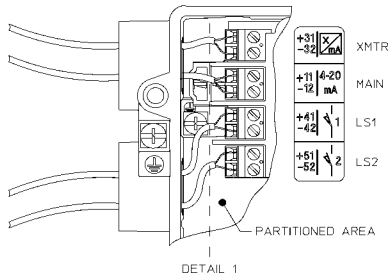
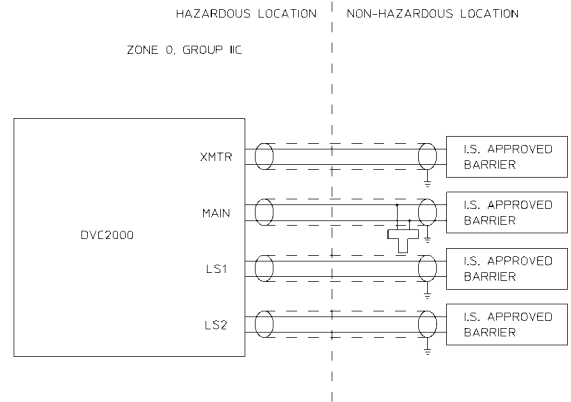

GE14581

Figure A-6. IECEX Loop Schematic

TYPE DVC2000

SN

MAX CURRENT: 30mA MAX VOLTAGE: 30VDC
 MAX SUPPLY: 100psi AMBIENT TEMP: -40°.80°C

FISHER CONTROLS INTL LLC
 MARSHALLTOWN, IOWA, USA
 MFG LOCATION:

IECEX CSA 05.0006X
Ex ia IIC T4(Tamb ≤ 80°C), T5(Tamb ≤ 40°C)
INSTALL PER DRAWING GE14581

WARNING:
 SUBSTITUTION OF COMPONENTS MAY IMPAIR INTRINSIC SAFETY.

REFER TO MANUAL FOR ADDITIONAL WARNINGS AND LIMITS

GE14380

CONDITIONS OF CERTIFICATION:
 THE EQUIPMENT SHALL BE CONNECTED IN ACCORDANCE WITH THE MANUFACTURER'S INSTALLATION INSTRUCTIONS TO INTRINSIC SAFETY BARRIERS THAT SATISFY THE FOLLOWING PARAMETERS FOR EACH SET OF TERMINALS.

- MAIN 4-20 mA:** $U_i = 30\text{ V}$, $I_i = 130\text{ mA}$, $P_i = 1\text{ W}$, $L_i = 0.55\text{ mH}$, $C_i = 5\text{ nF}$
XMTR CIRCUIT: $U_i = 28\text{ V}$, $I_i = 100\text{ mA}$, $P_i = 1\text{ W}$, $L_i = 0\text{ mH}$, $C_i = 5\text{ nF}$
LIMIT SWITCH 1 (LS1): $U_i = 16\text{ V}$, $I_i = 76\text{ mA}$, $P_i = 1\text{ W}$, $L_i = 0\text{ mH}$, $C_i = 5\text{ nF}$
LIMIT SWITCH 2 (LS2): $U_i = 16\text{ V}$, $I_i = 76\text{ mA}$, $P_i = 1\text{ W}$, $L_i = 0\text{ mH}$, $C_i = 5\text{ nF}$

Figure A-7. IECEX Nameplate; Intrinsicly Safe

Glossary

Alert Point

An adjustable value that, when exceeded, activates an alert.

Algorithm

A set of logical steps to solve a problem or accomplish a task. A computer program contains one or more algorithms.

Alphanumeric

Consisting of letters and numbers.

Analog Input Units

Units in which the analog input is displayed and maintained in the instrument.

ANSI (acronym)

The acronym ANSI stands for the American National Standards Institute

ANSI Class

Valve pressure/temperature rating.

Bench Set

Pressure, supplied to an actuator, required to drive the actuator through rated valve travel. Expressed in pounds per square inch.

Byte

A unit of binary digits (bits). A byte consists of eight bits.

Calibration Location

Where the instrument was last calibrated; either in the factory or in the field.

Configuration

Stored instructions and operating parameters for a FIELDVUE Instrument.

Control Loop

An arrangement of physical and electronic components for process control. The electronic components of the loop continuously measure one or more aspects of the process, then alter those aspects as necessary to achieve a desired process condition. A simple control loop measures only one variable. More sophisticated control loops measure many variables and maintain specified relationships among those variables.

Control Mode

Defines where the instrument reads its set point. The following control modes are available for a FIELDVUE Instrument:

Analog The instrument receives its travel set point over the 4–20 mA loop.

Digital The instrument receives its set point digitally, via the HART communications link.

Test This is not a user-selectable mode. The HART Communicator or AMS ValveLink Software places the instrument in this mode whenever it needs to move the valve, such as for calibration or diagnostic tests.

Control Mode, Restart

Determines the instrument control mode after a restart. See Control Mode for the available restart control modes.

Controller

A device that operates automatically to regulate a controlled variable.

Current-to-Pressure (I/P) Converter

An electronic component or device that converts a milliamp signal to a proportional pneumatic pressure output signal.

DVC2000 Series

Cycle Counter

The capability of a FIELDVUE instrument to record the number of times the travel changes direction. The change in direction must occur after the deadband has been exceeded before it can be counted as a cycle.

Cycle Counter Alert

Checks the difference between the Cycle Counter and the Cycle Counter Alert Point. Cycle Counter Alert is active when the cycle counter value exceeds the Cycle Counter Alert Point. It clears after you reset the Cycle Counter to a value less than the alert point.

Cycle Counter Alert Point

An adjustable value which, when exceeded, activates the Cycle Counter Alert. Valid entries are 0 to 4 billion cycles.

Cycle Counter Deadband

Region around the travel reference point, in percent of ranged travel, established at the last increment of the Cycle Counter. The deadband must be exceeded before a change in travel can be counted as a cycle. Valid entries are 0% to 100%. Typical value is between 2% and 5%.

Deviation

Usually, the difference between set point and process variable. More generally, any departure from a desired or expected value or pattern.

Device ID

Unique identifier embedded in the instrument at the factory.

Device Revision

Revision number of the interface software that permits communication between the HART Communicator and the instrument.

Drive Signal

The signal to the I/P converter from the printed wiring board. It is the percentage of the total microprocessor effort needed to drive the valve fully open.

Drive Signal Alert

Checks the drive signal and calibrated travel. If one of the following conditions exists for more than 20 seconds, the Drive Signal Alert is active. If none of the conditions exist, the alert is cleared.
If Zero Control Signal = Closed

The alert is active when:

drive signal <10% and calibrated travel >3%
drive signal >90% and calibrated travel <97%

If Zero Control Signal = Open

The alert is active when:

drive signal <10% and calibrated travel <97%
drive signal >90% and calibrated travel >3%

Equal Percentage

A valve flow characteristic where equal increments of valve stem travel produce equal percentage changes in existing flow. One of the input characteristics available for a FIELDVUE Instrument. See also, Linear and Quick Opening.

Feedback Signal

Indicates to the instrument the actual position of the valve. The travel sensor provides the feedback signal to the instrument printed wiring board assembly.

Firmware Revision

The revision number of the instrument firmware. Firmware is a program that is entered into the instrument at time of manufacture and cannot be changed by the user.

Free Time

Percent of time that the microprocessor is idle. A typical value is 25%. The actual value depends on the number of functions in the instrument that are enabled and on the amount of communication currently in progress.

Full Ranged Travel

Current, in mA, that corresponds with the point where ranged travel is maximum, i.e., limited by the mechanical travel stops.

Gain

The ratio of output change to input change.

Hardware Revision

Revision number of the Fisher Controls instrument hardware. The physical components of the instrument are defined as the hardware.

HART (acronym)

The acronym HART stands for Highway Addressable Remote Transducer.

HART Tag

An eight-character name that identifies the physical instrument.

HART Universal Revision

Revision number of the HART Universal Commands which are the communications protocol for the instrument.

Input Characteristic

The relationship between the ranged travel and ranged input. Possible values include: linear, equal percentage, and quick opening.

Input Current

The current signal from the control system that serves as the analog input to the instrument. See also Input Signal.

Input Range

The analog input signal range that corresponds to the travel range.

Input Signal

The current signal from the control system. The input signal can be displayed in milliamperes or in percent of ranged input.

Instrument Level

Determines the functions available for the instrument. See table B-1, page B-5.

Instrument Mode

Determines if the instrument responds to its analog input signal. There are two instrument modes:

In Service: For a fully functioning instrument, the instrument output changes in response to analog input changes. Typically changes to setup or calibration cannot be made when the instrument mode is In Service.

Out of Service: The instrument output does not change in response to analog input changes when the instrument mode is Out of Service. Some setup parameters can be changed only when the instrument mode is Out of Service.

Instrument Protection

Determines if commands from a HART device can calibrate and/or configure certain parameters in the instrument. There are two types of instrument protection:

Configuration and Calibration: Prohibits changing protected setup parameters; prohibits calibration.

None: Permits both configuration and calibration. The instrument is "unprotected."

Instrument Serial Number

The serial number assigned to the printed wiring board by the factory but can be changed during setup. The instrument serial number should match the serial number on the instrument nameplate.

Leak Class

Defines the allowable leakage by a valve when it is closed. Leak class numbers are listed in two standards: ANSI/FCI 70-2-1991 and IEC 534-4.

Linear

A valve flow characteristic where changes in flow rate are directly proportional to changes in valve stem travel. One of the input characteristics available for a FIELDVUE Instrument. See also, Equal Percentage and Quick Opening.

Linearity, dynamic

Linearity (independent) is the maximum deviation from a straight line best fit to the opening and closing curves and a line representing the average value of those curves.

Memory

A type of semiconductor used for storing programs or data. FIELDVUE instruments use three types of memory: Random Access Memory (RAM), Read Only Memory (ROM), and Non-Volatile Memory (NVM). See also these listings in this glossary.

Menu

A list of programs, commands, or other activities that you select by using the arrow keys to highlight the item then pressing ENTER, or by entering the numeric value of the menu item.

Minimum Closing Time

Minimum time, in seconds, for the travel to decrease through the entire ranged travel. This rate is applied to any travel decrease. Valid entries are 0 to 400 seconds. Deactivate by entering a value of 0 seconds.

Minimum Opening Time

Minimum time, in seconds, for the travel to increase through the entire ranged travel. This rate is applied to any travel increase. Because of friction, actual valve travel may not respond in exactly the same time frame. Valid entries are 0 to 400 seconds. Deactivate by entering a value of 0 seconds.

Non-Volatile Memory (NVM)

A type of semiconductor memory that retains its contents even though power is disconnected. NVM contents can be changed during configuration unlike ROM which can be changed only at time of instrument manufacture. NVM stores configuration restart data.

Parallel

Simultaneous: said of data transmission on two or more channels at the same time.

Polling Address

Address of the instrument. If the digital valve controller is used in a point-to-point configuration, set the polling address to 0. If it is used in a multidrop configuration, or split range application, set the polling address to a value from 0 to 15.

Pressure Sensor

A FIELDVUE instrument internal device that senses pneumatic pressure. DVC2000 Series digital valve controllers have one actuator pressure sensor.

Primary Master

Masters are communicating devices. A primary master is a communicating device permanently wired to a field instrument. Typically, a HART-compatible control system or a computer running AMS ValveLink Software is the primary master.

In contrast, a secondary master is not often permanently wired to a field instrument. The Model 375 Field Communicator or a computer running AMS ValveLink Software communicating through a HART modem could be considered a secondary master.

Note: If one type of master takes an instrument Out Of Service, the same type must put it In Service. For example, if a device set up as a primary master takes an instrument Out Of Service, a device set up as a primary master must be used to place the instrument In Service.

Quick Opening

A valve flow characteristic where most of the change in flow rate takes place for small amounts of stem travel from the closed position. The flow characteristic curve is basically linear through the first 40 percent of stem travel. One of the input characteristics available for a FIELDVUE Instrument. See also, Equal Percentage and Linear.

Random Access Memory (RAM)

A type of semiconductor memory that is normally used by the microprocessor during normal operation that permits rapid retrieval and storage of programs and data. See also Read Only Memory (ROM) and Non-Volatile Memory (NVM).

Rate

Amount of change in output proportional to the rate of change in input.

Read-Only Memory (ROM)

A memory in which information is stored at the time of instrument manufacture. You can examine but not change ROM contents.

Seat Load

Force exerted on the valve seat, typically expressed in pounds force per lineal inch of port circumference. Seat load is determined by shutoff requirements.

Set Point Filter Time

The time constant, in seconds, for the first-order input filter.

Software

Microprocessor or computer programs and routines that reside in alterable memory (usually RAM), as opposed to firmware, which consists of programs and routines that are programmed into memory (usually ROM) when the instrument is manufactured. Software can be manipulated during normal operation, firmware cannot.

Stroking Time

The time, in seconds, required to move the valve from its fully open position to fully closed, or vice versa.

Temperature Sensor

A device within the FIELDVUE instrument that measures the instrument's internal temperature.

Travel

Movement of the valve stem or shaft which changes the amount the valve is open or closed.

Travel Accumulator

The capability of a FIELDVUE instrument to record total change in travel. The value of the Travel Accumulator increments when the magnitude of the change exceeds the Travel Accumulator Deadband. To reset the Travel Accumulator, set it to zero.

Travel Accumulator Alert

Checks the difference between the Travel Accumulator value and the Travel Accumulator Alert Point. The Travel Accumulator Alert is active when the Travel Accumulator value exceeds the Travel Accumulator Alert Point. It clears after you reset the Travel Accumulator to a value less than the alert point.

Travel Accumulator Alert Point

An adjustable value which, when exceeded, activates the Travel Accumulator Alert. Valid entries are 0% to 4 billion %.

Travel Accumulator Deadband

Region around the travel reference point established at the last increment of the accumulator. This region must be exceeded before a change in travel can be accumulated. Valid entries are 0% to 100%.

Travel Alert

Checks the ranged travel against the travel high and low alert points. The travel alert is active if either the high or low point is exceeded. Once a high or low point is exceeded, the ranged travel must clear that point by the Travel Alert Deadband before the alert clears. Four travel alerts are available: Travel Alert Hi, Travel Alert Lo, Travel Alert Hi Hi, and Travel Alert Lo Lo.

Travel Alert Deadband

Travel, in percent of ranged travel, required to clear a travel alert, once it is active. Valid entries are -25% to 125%.

Travel Alert High Point

Value of the travel, in percent of ranged travel, which, when exceeded, sets the Travel Alert Hi alert. Valid entries are -25% to 125%.

Travel Alert High High Point

Value of the travel, in percent of ranged travel, which, when exceeded, sets the Travel Alert Hi Hi alert. Valid entries are -25% to 125%.

Travel Alert Low Point

Value of the travel, in percent of ranged travel, which, when exceeded, sets the Travel Alert Lo alert. Valid entries are -25% to 125%.

Travel Alert Low Low Point

Value of the travel, in percent of ranged travel, which, when exceeded, sets the Travel Alert Lo Lo alert. Valid entries are -25% to 125%.

Travel Cutoff

Defines the cutoff point for the travel, in percent of ranged travel. There are two travel cutoffs: high and low. Once travel exceeds the cutoff, the drive signal is set to either maximum or minimum, depending on the Zero Control Signal and if the cutoff is high or low. Minimum opening time or minimum closing time are not in effect while the travel is beyond the cutoff. Use the travel cutoff to obtain the desired seat load or to be sure the valve is fully open.

Travel Deviation

The difference between the analog input signal (in percent of ranged input), the “target” travel, and the actual “ranged” travel.

Travel Deviation Alert

Checks the difference between the target and the ranged travel. If the difference exceeds the Travel Deviation Alert Point for more than the Travel Deviation Time, the Travel Deviation Alert is active. It remains active until the difference is less than the Travel Deviation Alert Point.

Travel Deviation Alert Point

An adjustable value for the target travel and the ranged travel difference, expressed in percent. When this value is exceeded by the travel deviation for more than the Travel Deviation Time, the Travel Deviation Alert is active. Valid entries are 0% to 100%. Typically this is set to 5%.

Travel Deviation Time

The time, in seconds, that the travel deviation must exceed the Travel Deviation Alert Point before the alert is active. Valid entries are 1 to 60 seconds.

Travel Limit

A setup parameter that defines the maximum allowable travel (in percent of ranged travel) for the valve. During operation, the travel target will not exceed this limit. There are two travel limits: high and low. Typically the travel limit low will be used to keep the valve from going completely closed.

Travel Range

Travel, in percent of calibrated travel, that corresponds to the input range.

Travel Sensor

A device within the FIELDVUE instrument that senses valve stem or shaft movement.

Tuning

The adjustment of control terms or parameter values to produce a desired control effect.

Tuning Set

Preset values that identify gain settings for a FIELDVUE instrument. The tuning set and supply pressure together determine an instrument's response to input signal changes.

Watch Dog Timer

A timer that the microprocessor must rearm periodically. If the microprocessor is unable to rearm the timer, the instrument goes through reset.

Zero Control Signal

A setup parameter that determines whether the valve is fully open or fully closed when the input signal is 0%.

A

Actuator and Valve Information, 4-6

Alert Record, 4-9, B-7

Clearing, 4-9

Displaying, 4-9

Enabling Alert Groups, 4-9

Alerts

Displaying Alert Status, B-6

Failure Alerts, B-6

Valve Alerts, B-6

Analog Calibration Adjust, 4-10

Analog Input, B-4

Displaying Value, B-4

Analog Input Calibration, via Local Interface,
3-9

Analog Input

Calibration, 4-11

Range Hi, 4-6

Range Lo, 4-6

Analog Input Units, 4-6

Auto Calibrate Travel, 4-10

Auto Tuner, 4-10

B

Basic Setup, 3-3

Burst Mode

Commands, 4-4

Enabling, 4-4

C

Calibration

Analog Input, 4-11

via Local Interface, 3-9

Auto Calibrate Travel, 4-10

Manual Calibrate Travel, 4-10

Output Pressure Sensor, 4-12

Position Transmitter, via Local Interface,
3-10

Pressure Sensor, 4-12

Characteristic, 3-7

Communication Connections, 2-10

Component Replacement, 5-3

Connections

Electrical, 2-8, 2-9

Supply, 2-8

Control Mode, 4-4

Critical NVM Fail, Self Test Failure, enabling
to cause instrument shutdown, 4-9

Critical NVM Failure, B-6

Cycle Counter, Displaying Value, B-5

D

Date, 4-6

Descriptor, 4-6

Detailed Setup, via Local Interface, 3-7

Device ID, B-5

DVC2000, Hardware, B-5

Device Information, B-5

Device Revision, B-5

Diagnostic Messages, Codes and Details,
3-12

Check I/P Converter, 3-12

Check Mounting, 3-12

Check Supply, 3-12

Device Locked by HART, 3-12

Replace Main Board, 3-12

Shutdown Activated, 3-12

SWITCH 1 ???, 3-12

SWITCH 2 ???, 3-12

Travel Deviation, 3-12

Digital Calibration Adjust, 4-11

Drive Current Fail, Self Test Failure, enabling
to cause instrument shutdown, 4-9

Drive Current Failure, B-6

Drive Signal, B-4

Displaying Value, B-4

E

Electrical Connections, 2-8, 2-9

F

- Factory Default Settings, 3-4
- Failure Alerts, B-6
 - Critical NVM Fail, B-6
 - Drive Current Fail, B-6
 - Flash ROM Fail, B-7
 - No Free Time, B-7
 - Offline/Failed, B-6
 - Pressure Sensor Fail, B-6
 - Ref Voltage Fail, B-7
 - Temperature Sensor Fail, B-6
 - Travel Sensor Fail, B-6
- Feedback system, 2-2
- Field Communicator
 - Alphanumeric Keypad, C-2
 - Backlight Adjustment Key, C-3
 - Device Description Revision, C-6
 - Display, C-2
 - Enter Key, C-2
 - Function Key, C-3
 - Hot Key, C-4
 - Multifunction LED, C-3
 - Navigation Keys, C-2
 - Offline Menu, C-4
 - On/Off Key, C-2
 - Online Menu, C-6
 - Online Simulation, C-5
 - Polling, C-5
 - Scratchpad, C-4
 - Soft Input Panel Keyboard (SIP), C-3
 - System Information, C-5
 - Using the Touch Screen, C-3
- Firmware Revision, B-5
- Flash ROM Fail, Self Test Failure, enabling to cause instrument shutdown, 4-9
- Flash ROM Failure, B-7
- Free Time
 - Displaying Value, B-5
 - Self Test Failure, enabling to cause instrument shutdown, 4-9

H

- Hardware Revision, B-5
- HART Communicator
 - Specifications, C-2
 - Tab Key, C-2
- HART Tag, 4-6

Hot Key, Field Communicator, C-4

I

- I/P Converter
 - Assembly, 5-5
 - Removal, 5-5
 - Replacing, 5-5
- Input Characteristic, 4-7
- Input Range, 4-6
- Input Range High, 3-7
- Input Range Low, 3-7
- Instrument Clock, Setting, 4-9
- Instrument Level, 1-2, B-5
- Instrument Mode, 4-3
- Instrument Removal, 5-2
- Instrument Replacement, 5-2
- Instrument Serial Number, 4-6
- Instrument Status, B-5
- Integral Deadband, 4-8
- Integral Gain, 4-8
- Internal Temperature
 - Displaying Value, B-5
 - Self Test Failure, enabling to cause instrument shutdown, 4-9
- Internal voltage reference failure, Self Test Failure, enabling to cause instrument shutdown, 4-9

L

- Language Screen, via Local Interface, 3-3
- Language Selection Screen, 3-3
- LCD, First (Home) Screen, 3-2
- Limit Switches, Wiring, 2-9
- Local Control, via Local Interface, 3-11
- Local Interface, 1-2
- Local Interface Flow Chart, front cover
- Loop Schematics, Intrinsically Safe
 - ATEX, D-3
 - CSA, D-1
 - FM, D-2
 - IECEX, D-4

M

- Magnet Assembly, 1-2
- Magnetic Feedback Assembly, Replacing, 5-2
- Main Electronics
 - Installation, 5-3
 - Removal, 5-3
 - Replacing, 5-3
- Manual Calibrate Travel, 4-10
- Maximum Supply Pressure, 4-7
- Measured Variable Units and Ranges, 4-6
- Message, 4-6
- Minimum Closing Time, 4-8
- Minimum Opening Time, 4-8
- Mounting
 - Air-to-Close Sliding Stem Actuators, 2-4
 - Air-to-Open Sliding Stem (Linear) Actuators , 2-3
 - Fisher Type 657 Actuator, 2-4
 - Fisher Type 667, 2-3
 - Guidelines for Mounting on Quarter-Turn (Rotary) Acutators, 2-7
 - GX Actuators
 - Air-to-Close, 2-6
 - Air-to-Open , 2-5
 - Sliding Stem (Linear) Actuators, Air-to-Close, 2-4
 - Sliding Stem Actuators, Air-to-Open, 2-3

N

- Nameplates
 - ATEX Approval, Intrinsically Safe, D-3
 - CSA Approval, D-2
 - FM Approval, D-2
 - IECEX Approval, Intrinsically Safe, D-4
- No Free Time, B-7

O

- Offline/Failed, B-6
- Operational Status, B-7
- Options Board, 1-2
- Options Boards, 2-9
- Output Pressure, Displaying Value, B-4

- Output Pressure Sensor, Calibration, 4-12

P

- Parts
 - Kits, 6-2
 - Ordering, 6-2
 - Terminal Board Assembly, positioner, transmitter, limit switches, 6-2
- Pneumatic Relay
 - Assembly, 5-6
 - Removal, 5-6
 - Replacing, 5-6
- Pole Piece, 1-2
- Polling Address, 4-6
- Position Transmitter
 - Calibration, via Local Interface, 3-10
 - Wiring, 2-9
- Pressure Sensor Calibration, 4-12
- Pressure Sensor Failure, B6
- Pressure Units, 3-7, 4-6
- Principle of Operation, B-2
 - drive signal, B-2
 - input signal, B-2
 - pneumatic output signal, B-2
 - pressure signal, B-2
- Protection, 4-4

Q

- Quick Setup, via Local Interface, 3-4

R

- Reference Voltage Failure, B-7
- Restart Control Mode, 4-4
- Restarting the Instrument, 4-4
- Revision Information
 - DVC2000
 - Device, B-5
 - Firmware, B-5
 - Hardware, B-5
 - HART Universal, B-5
 - Field Communicator, Device Description, C-6

S

- Secondary Electronics
 - Assembly, 5-4

- Removal, 5-4
- Replacing, 5-4
- Self Test Failures, Displaying Status, B-6
- Self Test Failures for instrument shutdown, 4-9
- Serial Number
 - Instrument, 4-6
 - Valve, 4-6
- Set Point Filter Time, 4-8
- Setting Alerts, 4-9
- Setting Response, 4-7
- Specifications, A2
- Status Information, 3-2
- Supply Connections, 2-8
- Supply Pressure, Displaying Value, B-4
- Switch #1
 - Trip Point, 3-8
 - Closed, 3-8
- Switch #2, Trip Point, 3-8
- Switch #2 , Closed, 3-8

T

- Temperature Sensor Failure, B-6
- Temperature Units, 4-6
- Transmitter, 3-8
- Travel, B-4
 - Displaying Value, B-4
- Travel Accumulator, Displaying Value, B-5
- Travel Calibration, via Local Interface, 3-5

- Travel Cutoffs, 4-8
 - Travel Cutoff High, 4-9
 - Travel Cutoff Low, 4-9
- Travel Limits, 4-8
 - Travel Limit Low, 4-8
- Travel Limits , Travel Limit High, 4-8
- Travel Sensor, Self Test Failure, enabling to cause instrument shutdown, 4-10
- Travel Sensor Failure, B-6
- Troubleshooting, B-3
 - What are the observable symptoms?, B-3
 - What is a healthy unit, B-3
- Tuning
 - Automatic, 4-10
 - Manual, 4-10
 - via Local Interface, 3-6
- Tuning Set, 4-7

V

- Valve Alerts, B-6
- Valve Serial Number, 4-6
- Valve Set Point, B-4
 - Displaying Value, B-4
- Vent, 2-10
- Viewing Variables, B-4
 - Analog Input, Travel, Valve Set Point, Drive Signal and Output Pressure , B-4

Z

- Zero Control Signal, 3-7, 4-7



FIELDVUE, ValveLink, PlantWeb and Fisher are marks owned by Fisher Controls International LLC, a member of the Emerson Process Management business division of Emerson Electric Co. AMS Suite, Rosemount and Tri-Loop are marks owned by one of the Emerson Process Management group of companies. Emerson and the Emerson logo are trademarks and service marks of Emerson Electric Co. HART is a mark owned by the HART Communications Foundation. All other marks are the property of their respective owners. This product may be covered under pending patents.

The contents of this publication are presented for informational purposes only, and while every effort has been made to ensure their accuracy, they are not to be construed as warranties or guarantees, express or implied, regarding the products or services described herein or their use or applicability. We reserve the right to modify or improve the designs or specifications of such products at any time without notice.

Neither Emerson, Emerson Process Management, Fisher, nor any of their affiliated entities assumes responsibility for the selection, use and maintenance of any product. Responsibility for the selection, use and maintenance of any product remains with the purchaser and end-user.

Emerson Process Management

Fisher
Marshalltown, Iowa 50158 USA
Cernay 68700 France
Sao Paulo 05424 Brazil
Singapore 128461

www.Fisher.com

