

# 585C Series Piston Actuators

## Contents

Introduction .....	1
Scope of Manual .....	1
Description .....	2
Specifications .....	2
Principle of Operation .....	12
Actuator with Handwheel .....	12
Actuator with Spring Return .....	13
Type 585C Long-Stroke Construction .....	13
Installation .....	13
Bypass Assembly .....	15
Three-Way Valve Applications Note .....	15
Actuator Mounting .....	16
Size 25 & 50 Actuator Mounting .....	16
Size 60-130 Actuator Mounting .....	17
Stem Connector Assembly (Size 60-130) ..	17
Long-Stroke Actuator Mounting .....	18
Type 585C Handwheels .....	19
Handwheel Operation (Sizes 25 & 50) .....	19
Handwheel Operation (Sizes 60-130) .....	19
Long-Stroke Handwheel Operation .....	19
Maintenance (Sizes 25 & 50) .....	19
Replacing Handwheel Housing O-Ring or Thrust Bearings (Sizes 25 & 50) .....	20
Replacing Seals, Changing Action, or Changing Bias Spring(s) (Sizes 25 & 50) .	21
Maintenance (Sizes 60-130) .....	23
Side-Mounted Handwheel Maintenance (Sizes 60-130) .....	24
Disassembly of Handwheel Constructions (Sizes 60 and 68) .....	25
Disassembly of Handwheel Constructions (Sizes 80-130) .....	25
Reassembly (Sizes 60-130) .....	25
Type 585C Long-Stroke Maintenance .....	26
Non-Handwheel Construction .....	26
Handwheel Construction .....	26
Stem Connection Procedure .....	27
Parts Ordering .....	28
Parts Kits .....	28
Parts List .....	29
Sizes 25 & 50 .....	29
Sizes 60-130 .....	37
Long-Stroke Parts List .....	38



W9131-1

Figure 1. 585C Series Piston Actuator

## Introduction

### Scope of Manual

This instruction manual provides information on installation, maintenance, and parts ordering for the Type 585C piston actuators. Refer to separate instruction manuals for information about other equipment and accessories used with these actuators.

Do not install, operate, or maintain a Type 585C Series actuator without first ● being fully trained and qualified in valve, actuator, and accessory installation, operation, and maintenance, and ● carefully reading and understanding the contents of this manual. If you have any questions about these instructions, contact your Emerson Process Management™ sales office before proceeding.



# 585C Actuator

---

## Description

### *The Type 585C Actuator*

Type 585C pneumatic piston actuators ( figure 1) provide accurate throttling or on-off control of sliding-stem valves. The Type 585C actuator uses a double-acting cylinder, which requires air pressure for operation.

Size 25 and 50 actuators are available as a springless construction or with a bias spring. Depending on configuration, the bias spring will retract or extend the piston rod upon loss of cylinder air pressure. Size 60 through 130 actuators are available as springless constructions only.

Type 585C actuators are typically supplied with a Type DVC6000 digital valve controller, or a 3600 Series P/P or I/P analog positioner. The Type 585C actuator is available with a top-mounted or side-mounted manual handwheel, depending on actuator size.

### *The Type 585C Long-Stroke Actuator*

Type 585C Long-Stroke piston actuators are capable of travels up to 610 mm (24 inches). The Long-Stroke actuator is available with a manual handwheel, which can be used to open, close, or

position the valve. The manual handwheel may also be used as a stop to limit the upward travel of the valve plug.

Like the Type 585C actuator, the Type 585C Long-Stroke actuator typically is equipped with either the DVC6000 digital valve controller or 3600 Series positioner for throttling service. For on-off service, the actuator cylinder is loaded and unloaded through the operation of a solenoid valve, pneumatic switch, or similar equipment.

#### Note

**Neither Emerson, Emerson Process Management, nor any of their affiliated entities assumes responsibility for the selection, use and maintenance of any product. Responsibility for the selection, use, and maintenance of any product remains with the purchaser and end-user.**

## Specifications

Specifications for the Type 585C and Long-Stroke piston actuators are given in tables 1 and 2. Some specifications for an individual actuator as it originally comes from the factory are stamped on a nameplate attached to the yoke.

Table 1. 585C Specifications (sizes 25-130)

<p><b>Operating Pressure<sup>(1)</sup></b>  <b>Sizes 25-50</b>  <i>Maximum Allowable:</i> 10.3 bar (150 psig)  <i>Minimum Recommended:</i> 1.4 bar (20 psig)  <b>Sizes 60-130</b>  <i>Maximum Allowable:</i> See table 12  <i>Minimum Recommended:</i> 2.4 bar (35 psig)</p> <p><b>Travel</b>                  See table 6</p> <p><b>Thrust Capabilities</b>                  See tables 8 through 12</p> <p><b>Stroking Speeds</b>                  Varies with actuator size, actuator spring, travel, and supply pressure. If stroking speed is critical, consult your Emerson sales office</p> <p><b>Piston Area</b>                  See table 6</p> <p><b>Cylinder Volumetric Displacement</b>                  See table 6</p> <p><b>Operative Temperature Limits<sup>(1)</sup></b>  <b>For All Sizes</b>  <i>With Nitrile O-Rings:</i> -50 to 80°C (-58 to 175°F), standard  <i>With Fluorocarbon O-Rings:</i> -18 to 150°C (0 to 300°F), optional</p> <p><b>Yoke Boss and Valve Stem Diameters</b>                  See table 7</p> <p><b>Pressure Connections</b>  <b>Size 25-60</b>                  ■ 1/4 NPT internal (standard), or ■ 3/8 NPT internal (optional)  <b>Sizes 68-130</b>                  ■ 1/2 NPT internal (standard)</p> <p><b>Instrument Mounting</b>                  The Type 585C actuator has NAMUR mounting capability on sizes 25 through 130</p>	<p><b>Construction Materials</b></p> <table border="1"> <thead> <tr> <th>Part</th> <th>Material</th> </tr> </thead> <tbody> <tr> <td>Yoke</td> <td>Ductile Iron</td> </tr> <tr> <td>Piston</td> <td>Aluminum</td> </tr> <tr> <td>Cylinder</td> <td>Aluminum</td> </tr> <tr> <td>Bolting and Fasteners</td> <td>NCF (non-corroding finish)</td> </tr> <tr> <td>Springs (sizes 25 &amp; 50 only)</td> <td>Alloy Steel</td> </tr> <tr> <td>O-Rings</td> <td>Nitrile (std), Fluorocarbon</td> </tr> <tr> <td>Actuator Stem</td> <td>Chrome-plated Steel</td> </tr> <tr> <td>Stem Connection</td> <td>Stainless Steel</td> </tr> <tr> <td>Travel Indicator Scale</td> <td>Stainless Steel</td> </tr> <tr> <td>Paint</td> <td>Polyester Powder</td> </tr> <tr> <td>Cylinder Seal Bushings (sizes 60-130 only)</td> <td>Brass</td> </tr> <tr> <td>Stem Connector (sizes 60-130)</td> <td>Zinc-plated steel</td> </tr> </tbody> </table> <p><b>Approximate Weights (less positioner and handwheel)</b></p> <p><b>Size 25</b>                  2-1/8 inch yoke boss, 7 kg (16 pounds)                  2-13/16 inch yoke boss, 8 kg (17 pounds)</p> <p><b>Size 50</b>                  2-13/16 inch yoke boss, 20 kg (45 pounds)                  3-9/16 inch yoke boss, 22 kg (48 pounds)</p> <p><b>Size 60:</b> 31 kg (68 pounds)  <b>Size 68:</b> 54 kg (120 pounds)  <b>Size 80:</b> 102 kg (225 pounds)  <b>Size 100:</b> 113 kg (250 pounds)  <b>Size 130:</b> 188 kg (415 pounds)</p> <p><b>Options</b></p> <p><b>Sizes 25 and 50</b>                  ■ Top-mounted handwheel, see figures 6, 8, and 9 and table 14                  ■ Cylinder bypass valve ■ Limit switches ■ 4200 Series position transmitter</p> <p><b>Sizes 60-130</b>                  ■ Integral side-mounted handwheel, see figure 10</p> <p><b>Sizes 25-130</b>                  ■ FIELDVUE® mounting options                  ■ 377 Series trip valve system to fail actuator                  ■ up or ■ down or ■ lock in last position                  ■ Type 304 electrical valve stem position switch                  ■ Micro-Switch limit switches</p>	Part	Material	Yoke	Ductile Iron	Piston	Aluminum	Cylinder	Aluminum	Bolting and Fasteners	NCF (non-corroding finish)	Springs (sizes 25 & 50 only)	Alloy Steel	O-Rings	Nitrile (std), Fluorocarbon	Actuator Stem	Chrome-plated Steel	Stem Connection	Stainless Steel	Travel Indicator Scale	Stainless Steel	Paint	Polyester Powder	Cylinder Seal Bushings (sizes 60-130 only)	Brass	Stem Connector (sizes 60-130)	Zinc-plated steel
Part	Material																										
Yoke	Ductile Iron																										
Piston	Aluminum																										
Cylinder	Aluminum																										
Bolting and Fasteners	NCF (non-corroding finish)																										
Springs (sizes 25 & 50 only)	Alloy Steel																										
O-Rings	Nitrile (std), Fluorocarbon																										
Actuator Stem	Chrome-plated Steel																										
Stem Connection	Stainless Steel																										
Travel Indicator Scale	Stainless Steel																										
Paint	Polyester Powder																										
Cylinder Seal Bushings (sizes 60-130 only)	Brass																										
Stem Connector (sizes 60-130)	Zinc-plated steel																										

1. The pressure/temperature limits in this manual and any applicable standard or code limitation for valve should not be exceeded.

Table 2. 585C Specifications (Long-Stroke [Fabricated Yoke] Actuators)

<p><b>Cylinder Pressure<sup>(2)</sup></b>  <b>Minimum Recommended:</b> For valves with low thrust requirements—2.4 bar (35 psig); for all other valves—3.4 bar (50 psig)  <b>Maximum Allowable:</b> 127 mm (5-inch) to 305 mm (12-inch) diameter cylinders—17.2 bar (250 psig) unless limited by maximum allowable supply pressure of positioner or switching devices; 356 mm (14-inch) diameter cylinder—13.8 bar (200 psig) unless limited by maximum allowable supply pressure of positioner or switching device</p> <p><b>Travel Information</b>  <b>All Types:</b> 229 mm (9 inches) through 610 mm (24 inches) in 25 mm (1-inch) increments as shown in figure 15  <b>Travel Ratio for Handwheel Construction:</b> 10 complete revolutions of the wheel moves the stem 25 mm (1 inch)</p> <p><b>Thrust Information</b>          See table 13</p> <p><b>Operative Ambient Temperature<sup>(1, 2)</sup></b>  <b>For All Sizes</b>  <i>With Nitrile O-Rings:</i> –50 to 80°C (–58 to 175°F), standard  <i>With Fluorocarbon O-Rings:</i> –18 to 150°C (0 to 300°F), optional</p>	<p><b>Piston Diameters and Areas</b>          See table 13</p> <p><b>Yoke Boss and Valve Stem Diameters</b>          See table 7</p> <p><b>Pressure Connections</b>          Standard is 1/4 NPT. For larger sizes, consult your Emerson Process Management sales office</p> <p><b>Construction Materials</b></p> <table border="1" style="width: 100%;"> <thead> <tr> <th>Part</th> <th>Material</th> </tr> </thead> <tbody> <tr> <td>Cylinder Body: 127 mm through 356 mm (5-inch through 14-inch)</td> <td>Steel, chrome plated</td> </tr> <tr> <td>Piston Rod</td> <td>Steel, chrome plated</td> </tr> <tr> <td>Yoke</td> <td>Structural steel</td> </tr> <tr> <td>Stem Connector</td> <td>Stainless steel</td> </tr> <tr> <td>Piston</td> <td>Aluminum</td> </tr> <tr> <td>Bolting and fasteners</td> <td>NCF</td> </tr> <tr> <td>O-rings</td> <td>Nitrile</td> </tr> </tbody> </table> <p><b>Options</b>          ■ High temperature piston seals to 177°C (350°F), ■ 377 Series trip valves to fail actuator up, down, or lock in last position, ■ Limit switches, ■ Integral side-mounted handwheel</p>	Part	Material	Cylinder Body: 127 mm through 356 mm (5-inch through 14-inch)	Steel, chrome plated	Piston Rod	Steel, chrome plated	Yoke	Structural steel	Stem Connector	Stainless steel	Piston	Aluminum	Bolting and fasteners	NCF	O-rings	Nitrile
Part	Material																
Cylinder Body: 127 mm through 356 mm (5-inch through 14-inch)	Steel, chrome plated																
Piston Rod	Steel, chrome plated																
Yoke	Structural steel																
Stem Connector	Stainless steel																
Piston	Aluminum																
Bolting and fasteners	NCF																
O-rings	Nitrile																

1. These terms are defined in ANSI/ISA S51.1.

2. The pressure/temperature limits in this manual and any applicable standard or code limitation for valve should not be exceeded.

Table 3. 585C Specifications (3600 Series Positioners)

**Available Configurations**

- **Pneumatic (P/P) Positioner:** Type 3610JP and 3611JP
- **Electro-Pneumatic (I/P) Positioner:** Type 3620JP and 3621JP

**Application by Size**

- **Size 25 and 50:** Type 3611JP and 3621JP
- **Size 60-130 and Type 585C Long-Stroke:** Type 3610JP and 3620JP

**Input Signal<sup>(1)</sup>**

**Type 3610JP and 3611JP:**

*Standard:* ■ 0.2 to 1.0 bar (3 to 15 psig), ■ 0.4 to 2.0 bar (6 to 30 psig), or ■ split range, see table 4  
*Adjustable:* Zero is adjustable from 0.07 to 1.5 bar (1 to 22 psig) for standard valve travels. Span is adjustable from 0.2 to 2.0 bar (3.2 to 28.8 psi) for standard valve travels.

**Type 3620JP and 3621JP:**

4 to 20 mA dc constant current with 30 VDC maximum compliance voltage. Minimum terminal voltage is 2.4 VDC at 20 mA. Split range is also available, see table 4.

**Equivalent Circuit**

**Type 3620JP and 3621JP:** 120 ohms shunted by three 5.6 V zener diodes

**Output Signal<sup>(1)</sup>**

Pneumatic pressure as required by the actuator up to full supply pressure

**Action<sup>(2)</sup>:** Field-reversible between ■ direct and ■ reverse within the pneumatic positioner

**Typical Performance**

*(Refer to table 5 for typical performance for Type 3611JP and 3621JP Positioners)*

**Independent Linearity<sup>(1)</sup>**

*Direct-Acting Type 3610JP and 3620JP:* ±1.25% of output span

*Reverse-Acting Type 3610JP and 3620JP:* ±0.5% of output span

**Hysteresis<sup>(1)</sup>**

*Type 3610JP:* 0.5% of output span

*Type 3620JP:* 0.6% of output span

**Deadband<sup>(1)</sup>:** 0.1% of input span

**Electromagnetic Interference (EMI)<sup>(1)</sup> for 3620JP and 3621JP:**

When tested per IEC 60801-3, steady-state deviation is less than ±1% at an electromagnetic

field strength of 30 V/m from 20 to 1000 MHz. Positioner is tested with cover on and with external wiring in rigid metal conduit.

**Maximum Supply Air Demand<sup>(3)</sup>**

**Type 3610JP, 3620JP, 3611JP, and 3621JP:**  
*5.2 Bar (75 Psig) Supply:* 37 normal m<sup>3</sup>/hour (1380 scfh)

*6.9 Bar (100 Psig) Supply:* 46 normal m<sup>3</sup>/hour (1700 scfh)

**Supply Pressure<sup>(1, 4)</sup>**

**Minimum Recommended:** 0.3 bar (5 psig) above actuator requirement

**Maximum:** 10.3 bar (150 psig) or maximum pressure rating of the actuator, whichever is lower

**Steady-State Air Consumption<sup>(3)</sup>**

**Type 3610JP:** 0.64 normal m<sup>3</sup>/hour (24 scfh) at 6.9 bar (100 psig) supply pressure

**Type 3620JP:** 0.93 normal m<sup>3</sup>/hour (35 scfh) at 6.9 bar (100 psig) supply pressure

**Operative Temperature Limits<sup>(1, 4)</sup>**

−40 to 82°C (−40 to 180°F)

**Housing Classification for 3620JP and 3621JP**

NEMA 3, IEC 60529 IP54; Instrument should be mounted with vent on side or bottom to meet weatherproofing classification

**Electrical Classification for 3620JP and 3621JP**

Refer to the Type 3610J and 3620J Series Positioners Instruction Manual - Form 5208 for specific approvals

**Construction Materials**

**All Positioners:**

*Case:* Low copper aluminum alloy

*Cover:* Polyester plastic

*Feedback Lever:* Stainless steel

*Range Spring:* Zinc-plated steel

*Input Module and Relay Diaphragms:* Nitrile and polyester fiber

*Relay Valve Plugs and Seats:* Stainless steel

*Tubing:* Copper (standard)

*Fittings:* Brass (standard)

*Gauges:* Chrome-plated brass connection with plastic case

**Type 3620JP and 3621JP:**

*Housing and Cap:* Low copper aluminum alloy

-continued-

Table 3. 585C Specifications (3600 Series Positioners) (continued)

<p><b>Pressure Connections</b></p> <p>1/4 NPT internal</p> <p><b>Conduit Connection for Type 3620JP and 3621JP</b></p> <p>1/2 NPT internal (standard), M20 or PG13 adaptor (optional)</p>	<p><b>Options</b></p> <p><b>Type 3610JP, 3611JP, 3620JP, and 3621JP:</b></p> <p>■ Supply pressure gauge, ■ tire valves, or ■ plugs</p> <p><b>Approximate Weight</b></p> <p><b>3610JP and 3611JP:</b> 2.5 kg (5.6 pounds)</p> <p><b>3620JP and 3621JP:</b> 3.6 kg (8.0 pounds)</p>
---	---

1. These terms are defined in ISA Standard S51.1.
2. For direct action, an increasing input signal extends the actuator rod. For reverse action, an increasing input signal retracts the actuator rod.
3. Normal m<sup>3</sup>/hr—normal cubic meters per hour (0°C and 1.01325 bar absolute). Scfh—standard cubic feet per hour (60°F and 14.7 psia).
4. The pressure/temperature limits in this manual and any applicable standard or code limitation for valve should not be exceeded.

Table 4. Split-Ranging Capabilities

TYPE 3610JP/3611JP PNEUMATIC (P/P) POSITIONER				
Split	0.2 to 1.0 Bar (3 to 15 Psig) Input Signal		0.4 to 2.0 Bar (6 to 30 Psig) Input Signal	
	Bar	Psig	Bar	Psig
Two-way	0.2 to 0.6	3 to 9	0.4 to 1.2	6 to 18
	0.6 to 1.0	9 to 15	1.2 to 2.0	18 to 30
Three-way	0.2 to 0.5	3 to 7	0.4 to 0.9	6 to 14
	0.5 to 0.7	7 to 11	0.9 to 1.5	14 to 22
	0.7 to 1.0	11 to 15	1.5 to 2.0	22 to 30
TYPE 3620JP/3621JP ELECTRO-PNEUMATIC (I/P) POSITIONER <sup>(1)</sup>				
Split	4 to 20 Milliampere Input Signal			
Two-way	4 to 12			
	12 to 20			
Three-way	4 to 9.3			
	9.3 to 14.7			
				14.7 to 20

1. Hazardous area approvals are not available with split range applications.

Table 5. Typical Performance Specifications<sup>(1)</sup> for Type 3611JP and Type 3621JP Positioners with Size 25 and 50 Actuators

Characteristic	Size 25 Actuator <sup>(8)</sup>	Size 50 Actuator <sup>(8)</sup>
Deadband <sup>(1,2)</sup>	0.1% of input span	0.1% of input span
Step Response <sup>(1,3,5)</sup>	0.3 seconds	0.3 seconds
Steady-State Air Consumption <sup>(2,4,7)</sup>	0.64 normal m <sup>3</sup> /hr (24 scfh)	0.64 normal m <sup>3</sup> /hr (24 scfh)
Hysteresis <sup>(3)</sup>	0.5% of output span	0.5% of output span
Terminal-Based Linearity <sup>(2,6)</sup>	1% of output span	1% of output span
Frequency Response <sup>(1,2)</sup> (-6 dB)	2 Hz	2 Hz
Supply Pressure Sensitivity	10% change in supply pressure changes the actuator stem position less than 0.1%	

1. Performance tests are based on 6.9 bar (100 psig) supply pressure and lightest actuator springs. Performance will vary with other pressures and springs.
2. These terms are defined in ISA Standard S51.1.
3. Step response is the time for the actuator to reach 63 percent of expected travel after a 10 percent step change in input signal.
4. At 6.9 bar (100 psig) supply pressure. Scfh—standard cubic feet per hour (60°F and 14.7 psia). Normal m<sup>3</sup>/hr-cubic meters per hour (0°C and 1.01325 bar).
5. Type 3621JP positioner step response equals 0.4 seconds.
6. Type 3621JP positioner terminal-based linearity equals ±2.25%.
7. Type 3621JP positioner steady-state air consumption equals 0.93 normal m<sup>3</sup>/hr (35 scfh).
8. Size 25 and 50 actuators tested with appropriate parallel flexure (key 179).

Table 6. Type 585C Piston Cylinder Clearance Volumes

PISTON AT TOP OF CYLINDER (SPRINGS BELOW PISTON FOR SIZE 25 AND 50)								
Actuator Size	Piston Area		Maximum Actuator Travel		Upper Clearance Volume		Volume Below Piston	
	cm <sup>2</sup>	Inches <sup>2</sup>	cm	Inches	cm <sup>3</sup>	Inches <sup>3</sup>	cm <sup>3</sup>	Inches <sup>3</sup>
25	168	26	2.9	1.125	104	6.3	1750	107
50	303	47	5.1	2	330	20	5200	320
60	358	55.5	5.1	2	310	19	2700	163
			10	4	310	19	4400	270
			20	8	310	19	8200	500
68	571	88.5	5.1	2	1230	75	7500	460
			10.2	4	1230	75	7500	460
			20.3	8	1230	75	13300	810
80	571	88.5	10.2	4	1230	75	7500	460
			20.3	8	1230	75	13300	810
100	842	130.5	10.2	4	1700	104	10700	650
			20.3	8	1700	104	19200	1170
130	1430	221.5	10.2	4	4600	280	18500	1130
			20.3	8	4600	280	33000	2000
PISTON AT BOTTOM OF CYLINDER (SPRINGS ABOVE PISTON FOR SIZE 25 AND 50)								
Actuator Size	Piston Area		Maximum Actuator Travel		Lower Clearance Volume		Volume Above Piston	
	cm <sup>2</sup>	Inches <sup>2</sup>	cm	Inches	cm <sup>3</sup>	Inches <sup>3</sup>	cm <sup>3</sup>	Inches <sup>3</sup>
25	168	26	2.9	1.125	77	4.7	1790	109
50	303	47	5.1	2	350	22	5200	320

Table 7. Yoke Boss and Valve Stem Diameters

ACTUATOR SIZE	YOKE BOSS DIAMETER		VALVE STEM DIAMETER	
	mm	Inches	mm	Inches
25	54	2-1/8	9.5	3/8
	71	2-13/16	12.7	1/2
50	71	2-13/16	12.7	1/2
	90	3-9/16	19.1	3/4
60	90	3-9/16	19.1	3/4
68	90	3-9/16	19.1	3/4
80	127	5, 5H	25.4	1
			31.8	1-1/4
100	127	5, 5H	25.4	1
			31.8	1-1/4
130	127	5, 5H	25.4	1
			31.8	1-1/4
Long Stroke	127	5H <sup>(1)</sup>	25.4 or 31.8	1 or 1-1/4
	178	7	50.8	2

1. Heavy actuator to bonnet bolting.

# 585C Actuator

## Actuator Thrust Capabilities

Table 8. Type 585C Size 25 and 50 Actuator Thrust Capabilities, U.S. Units (spring retracts actuator stem)

ACTUATOR SIZE	SPRING RATE, lb/in	ACTUATOR STEM TRAVEL, INCHES	SPRING THRUST W/ ACTUATOR STEM RETRACTED, POUNDS	SPRING THRUST W/ ACTUATOR STEM EXTENDED, POUNDS	NET THRUST FOR TYPE 585C WITH ACTUATOR STEM FULLY EXTENDED AT FULL TRAVEL										SPRINGS USED, BY COLOR
					Operating Pressure, psig										
					40	50	60	70	80	90	100	110	125	150	
					Force, Pounds										
25	0	All	0	0	1040	1300	1560	1820	2080	2340	2600	2860	3250	3900	Springs Not Used
	200	0.5625	200	313	730	990	1250	1510	1760	2020	2280	2540	2930	3580	Gold
		0.75	200	350	690	950	1210	1470	1730	1990	2250	2510	2900	3550	
		0.875	200	375	660	920	1180	1440	1700	1960	2220	2480	2870	3520	
		1.125	200	425	610	870	1130	1390	1650	1910	2170	2430	2820	3470	
	400	0.5625	400	625	410	670	930	1190	1450	1710	1970	2230	2620	3270	Light Green
		0.75	400	700	340	600	860	1120	1380	1640	1900	2160	2550	3200	
		0.875	400	750	290	550	810	1070	1330	1590	1850	2110	2500	3150	
		1.125	400	850	190	450	710	970	1230	1490	1750	2010	2400	3050	
	500	0.5625	500	781	260	520	780	1040	1300	1560	1820	2080	2460	3110	White
		0.75	500	875	160	420	680	940	1200	1460	1720	1980	2370	3020	
		0.875	500	938	100	360	620	880	1140	1400	1660	1920	2310	2960	
1.125		500	1063	X	240	500	760	1010	1270	1530	1790	2180	2830		
700	0.5625	700	1094	X	200	460	720	980	1240	1500	1760	2150	2800	Gold & White	
	0.75	700	1225	X	70	330	590	850	1110	1370	1630	2020	2670		
	0.875	700	1313	X	X	250	510	760	1020	1280	1540	1930	2580		
	1.125	700	1488	X	X	70	330	590	850	1110	1370	1760	2410		
900	0.5625	900	1406	X	X	150	410	670	930	1190	1450	1840	2490	Light Green & White	
	0.75	900	1575	X	X	X	240	500	760	1020	1280	1670	2320		
	0.875	900	1688	X	X	X	130	390	650	910	1170	1560	2210		
	1.125	900	1913	X	X	X	X	160	420	680	940	1330	1980		
50	0	All	0	0	1840	2300	2760	3220	3680	4140	4600	5060	5750	6900	Springs Not Used
	330	0.75	330	578	1310	1780	2250	2720	3190	3660	4140	4610	5310	6490	Pink
		0.875	330	619	1270	1740	2210	2680	3150	3620	4090	4570	5270	6450	
		1.125	330	701	1180	1660	2130	2600	3070	3540	4010	4480	5190	6370	
		1.5	330	825	1060	1530	2000	2470	2950	3420	3890	4360	5070	6250	
		2	330	990	900	1370	1840	2310	2780	3250	3720	4190	4900	6080	
	600	0.75	600	1050	840	1310	1780	2250	2720	3190	3660	4130	4840	6020	Light Blue
		0.875	600	1125	760	1230	1700	2170	2650	3120	3590	4060	4770	5950	
		1.125	600	1275	610	1080	1550	2020	2500	2970	3440	3910	4620	5800	
		1.5	600	1500	390	860	1330	1800	2270	2740	3210	3680	4390	5570	
		2	600	1800	90	560	1030	1500	1970	2440	2910	3380	4090	5270	
	930	0.75	930	1628	260	730	1200	1670	2140	2610	3090	3560	4260	5440	Pink & Light Blue
0.875		930	1744	140	610	1080	1560	2030	2500	2970	3440	4150	5330		
1.125		930	1976	X	380	850	1320	1790	2270	2740	3210	3910	5090		
1.5		930	2325	X	30	500	970	1450	1920	2390	2860	3570	4750		
2		930	2790	X	X	40	510	980	1450	1920	2390	3100	4280		
1550	0.75	1550	2710	X	X	110	580	1050	1520	1990	2460	3165	4345	Green	
	0.875	1550	2906	X	X	X	385	855	1325	1795	2265	2970	4150		
	1.125	1550	3294	X	X	X	X	465	935	1405	1875	2580	3760		
	1.5	1550	3875	X	X	X	X	X	355	825	1295	2000	3180		
	2	1550	4650	X	X	X	X	X	X	50	520	1225	2405		
1880	0.75	1880	3290	X	X	X	X	470	940	1410	1880	2585	3765	Pink & Green	
	0.875	1880	3525	X	X	X	X	235	705	1175	1645	2350	3530		
	1.125	1880	3995	X	X	X	X	X	235	705	1175	1880	3060		
	1.5	1880	4700	X	X	X	X	X	X	X	470	1175	2355		
	2	1880	5640	X	X	X	X	X	X	X	X	235	1415		

X—Indicates where the listed supply pressure is not sufficient to overcome the opposing bias spring effect.

# Instruction Manual

Form 5353  
June 2007

# 585C Actuator

Table 9. Type 585C Size 25 and 50 Actuator Thrust Capabilities, Metric Units (spring retracts actuator stem)

ACTUATOR SIZE	SPRING RATE, N/mm	ACTUATOR STEM TRAVEL, mm	SPRING THRUST W/ ACTUATOR STEM RETRACTED, N	SPRING THRUST W/ ACTUATOR STEM EXTENDED, N	NET THRUST FOR TYPE 585C WITH ACTUATOR STEM FULLY EXTENDED AT FULL TRAVEL										SPRINGS USED, BY COLOR
					Operating Pressure, bar										
					2.8	3.4	4.1	4.8	5.5	6.2	6.9	7.6	8.6	10.3	
					Force, N										
25	0	All	0	0	4626	5783	6939	8096	9252	10,409	11,565	12,722	14,457	17,348	Springs Not Used
	35.0	14.3	890	1393	3247	4404	5560	6717	7829	8985	10,142	11,298	13,033	15,925	Gold
		19.1	890	1558	3069	4226	5382	6539	7695	8852	10,008	11,165	12,900	15,791	
		22.2	890	1669	2936	4092	5249	6405	7562	8718	9875	11,032	12,766	15,658	
		28.6	890	1891	2713	3870	5026	6183	7340	8496	9653	10,809	12,544	15,435	
	70.1	14.3	1780	2781	1824	2980	4137	5293	6450	7606	8763	9919	11,654	14,546	Light Green
		19.1	1780	3115	1512	2669	3825	4982	6139	7295	8452	9608	11,343	14,234	
		22.2	1780	3338	1290	2447	3603	4760	5916	7073	8229	9386	11,121	14,012	
		28.6	1780	3783	845	2002	3158	4315	5471	6628	7784	8941	10,676	13,567	
	87.6	14.3	2225	3475	1156	2313	3470	4626	5783	6939	8096	9252	10,943	13,834	White
19.1		2225	3894	712	1868	3025	4181	5338	6494	7651	8807	10,542	13,434		
22.2		2225	4174	445	1601	2758	3914	5071	6227	7384	8541	10,275	13,167		
28.6		2225	4730	X	1068	2224	3381	4493	5649	6806	7962	9697	12,588		
122.6	14.3	3115	4868	X	890	2046	3203	4359	5516	6672	7829	9564	12,455	Gold & White	
	19.1	3115	5451	X	311	1468	2624	3781	4938	6094	7251	8985	11,877		
	22.2	3115	5843	X	X	1112	2269	3381	4537	5694	6850	8585	11,476		
	28.6	3115	6622	X	X	311	1468	2624	3781	4938	6094	7829	10,720		
157.7	14.3	4005	6257	X	X	667	1824	2980	4137	5293	6450	8185	11,076	Light Green & White	
	19.1	4005	7009	X	X	X	1068	2224	3381	4537	5694	7428	10,320		
	22.2	4005	7512	X	X	X	578	1735	2891	4048	5204	6939	9831		
	28.6	4005	8513	X	X	X	X	712	1868	3025	4181	5916	8807		
50	0	All	0	0	8180	10,200	12,300	14,300	16,400	18,400	20,500	22,500	25,600	30,700	Springs Not Used
	57.8	19.1	1468	2571	5827	7918	10,008	12,099	14,190	16,280	18,416	20,506	23,620	28,869	Pink
		22.2	1468	2753	5649	7740	9831	11,921	14,012	16,102	18,193	20,328	23,442	28,691	
		28.6	1468	3118	5249	7384	9475	11,565	13,656	15,747	17,837	19,928	23,086	28,335	
		38.1	1468	3670	4715	6806	8896	10,987	13,122	15,213	17,303	19,394	22,552	27,801	
		50.8	1468	4404	4003	6094	8185	10,275	12,366	14,457	16,547	18,638	21,796	27,045	
	105.1	19.1	2669	4671	3736	5827	7918	10,008	12,099	14,190	16,280	18,371	21,529	26,778	Light Blue
		22.2	2669	5004	3381	5471	7562	9653	11,788	13,878	15,969	18,060	21,218	26,467	
		28.6	2669	5671	2713	4804	6895	8985	11,121	13,211	15,302	17,392	20,551	25,800	
		38.1	2669	6672	1735	3825	5916	8007	10,097	12,188	14,279	16,369	19,528	24,777	
162.9	19.1	4137	7242	1157	3247	5338	7428	9519	11,610	13,745	15,836	18,949	24,198	Pink & Light Blue	
	22.2	4137	7758	623	2713	4804	6939	9030	11,121	13,211	15,302	18,460	23,709		
	28.6	4137	8790	X	1690	3781	5872	7962	10,097	12,188	14,279	17,392	22,641		
	38.1	4137	10,342	X	133	2224	4315	6450	8541	10,631	12,722	15,880	21,129		
271.4	19.1	4137	12,410	X	X	178	2269	4359	6450	8541	10,631	13,789	19,038	Green	
	22.2	4137	12,410	X	X	X	X	X	X	X	X	X	X		
	28.6	6894	12054	X	X	489	2580	4670	6761	8852	10942	14078	19,328		
	38.1	6894	12925	X	X	X	1712	3803	5894	7984	10075	13211	18,460		
329.2	19.1	6894	14652	X	X	X	X	X	X	X	X	X	X	Pink & Green	
	22.2	6894	14652	X	X	X	X	X	X	X	X	X	X		
	28.6	6894	17236	X	X	X	X	X	X	X	X	X	X		
	38.1	6894	20683	X	X	X	X	X	X	X	X	X	X		
329.2	19.1	8362	14634	X	X	X	X	2091	4181	6272	8362	11498	16,748	Pink & Green	
	22.2	8362	15679	X	X	X	X	1045	3136	5226	7317	10453	15,702		
	28.6	8362	17770	X	X	X	X	X	1045	3136	5226	8362	13,612		
	38.1	8362	20906	X	X	X	X	X	X	X	2091	5226	10,476		
	50.8	8362	25087	X	X	X	X	X	X	X	X	1045	6294		

X—Indicates where the listed supply pressure is not sufficient to overcome the opposing bias spring effect.

# 585C Actuator

Table 10. Type 585C Size 25 and 50 Actuator Thrust Capabilities, U.S. Units (spring extends actuator stem)

ACTUATOR SIZE	SPRING RATE, lb/in	SPRING THRUST W/ ACTUATOR STEM EXTENDED, POUNDS	TOTAL THRUST FOR TYPE 585CR WITH ACTUATOR STEM FULLY EXTENDED										SPRINGS USED, BY COLOR
			Operating Pressure, psig <sup>(1)</sup>										
			40	50	60	70	80	90	100	110	125	150	
			Force, Pounds										
25 <sup>(2)</sup>	0	0	1040	1300	1560	1820	2080	2340	2600	2860	3250	3900	Springs Not Used
	200	200	1240	1500	1760	2020	2280	2540	2800	3060	3450	X	Gold
	400	400	1440	1700	1960	2220	2480	2740	3000	3260	3650	X	Light Green
	500	500	1540	1800	2060	2320	2580	2840	3100	3360	3750	X	White
	700	700	1740	2000	2260	2520	2780	3040	3300	3560	X	X	Gold & White
	900	900	1940	2200	2460	2720	2980	3240	3500	3760	X	X	Light Green & White
50 <sup>(3)</sup>	0	0	1840	2300	2760	3220	3680	4140	4600	5060	5750	6900	Springs Not Used
	330	330	2210	2680	3150	3620	4090	4560	5030	5500	6205	X	Pink
	600	600	2480	2950	3420	3890	4360	4830	5300	5770	6475	X	Light Blue
	930	930	2810	3280	3750	4220	4690	5160	5630	6100	6805	X	Pink & Light Blue
	1550	1550	3430	3900	4370	4840	5310	5780	6250	6720	X	X	Green
	1880	1880	3760	4230	4700	5170	5640	6110	6580	7050	X	X	Pink & Green

X—Indicates where the listed supply pressure is not sufficient to overcome the opposing bias spring effect.  
 1. The maximum design pressure for size 25 and 50 actuator is 150 psig.  
 2. Maximum thrust is 3900 lbs.  
 3. Maximum thrust is 6900 lbs.

Table 11. Type 585C Size 25 and 50 Actuator Thrust Capabilities, Metric Units (spring extends actuator stem)

ACTUATOR SIZE	SPRING RATE, N/mm	SPRING THRUST W/ ACTUATOR STEM EXTENDED, N	TOTAL THRUST FOR TYPE 585CR WITH ACTUATOR STEM FULLY EXTENDED										SPRINGS USED, BY COLOR
			Operating Pressure, bar <sup>(1)</sup>										
			2.8	3.4	4.1	4.8	5.5	6.2	6.9	7.6	8.6	10.3	
			Force, N										
25 <sup>(2)</sup>	0	0	4626	5782	6939	8095	9251	10408	11565	12721	14456	17347	Springs Not Used
	35.0	890	5516	6672	7828	8985	10141	11298	12454	13610	15346	X	Gold
	70.0	1780	6405	7562	8718	9874	11031	12188	13344	14500	16235	X	Light Green
	87.6	2225	6850	8006	9163	10319	11476	12632	13789	14945	16680	X	White
	122.6	3115	7740	8896	10052	11209	12365	13655	14678	15835	X	X	Gold & White
	157.6	4005	8629	9786	10942	12099	13255	14412	15568	16724	X	X	Light Green & White
50 <sup>(3)</sup>	0	0	8180	10200	12300	14300	16400	18400	20500	22500	25600	30700	Springs Not Used
	57.8	1468	9830	11921	14011	16102	18192	20282	22373	24464	27600	X	Pink
	105.1	2670	11031	13122	15212	17303	19393	21484	23574	25665	28800	X	Light Blue
	162.8	4135	12499	14589	16680	18770	20861	22952	25042	27133	30269	X	Pink & Light Blue
	271.4	6894	15256	17347	19438	21528	23619	25709	27800	29891	X	X	Green
	329.2	8362	16724	18815	20906	22996	25087	27177	29268	31358	X	X	Pink & Green

X—Indicates where the listed supply pressure is not sufficient to overcome the opposing bias spring effect.  
 1. The maximum design pressure for size 25 and 50 actuator is 10.3 bar.  
 2. Maximum thrust is 17347 N.  
 3. Maximum thrust is 31358 N.

Table 12. Type 585C Thrust (springless construction)

ACTUATOR SIZE	PISTON AREA cm <sup>2</sup>	TOTAL THRUST FOR TYPE 585C <sup>(1)</sup>										MAXIMUM ALLOWABLE THRUST Newtons
		Operating Pressure, bar <sup>(3)</sup>										
		2.8	3.4	4.1	4.8	5.5	6.2	6.9	7.6	8.6	10.3	
Force, Newtons <sup>(2)</sup>												Newton
25	168	4630	5780	6940	8100	9260	10400	11600	12700	14500	17300	17300
50	303	8180	10200	12300	14300	16400	18400	20500	22500	25600	30700	31400
60	358	9880	12300	14800	17300	19800	22200	24700	27200	30900	36900	36900
68	571	15700	19700	23600	27600	31500	35400	39400	43300	49200	55600	55600 <sup>(4)</sup>
80	571	15700	19700	23600	27600	31500	35400	39400	43300	49200	58700	58700
100	842	23200	29000	34800	40600	46400	52200	58000	63900	72600	86700	86700
130	1430	39400	49300	59100	69000	78700	88500	98800	108100	X	X	111200
ACTUATOR SIZE	PISTON AREA Inches <sup>2</sup>	Operating Pressure, psig <sup>(3)</sup>										MAXIMUM ALLOWABLE THRUST Pounds
		40	50	60	70	80	90	100	110	125	150	
		Force, Pounds <sup>(2)</sup>										
25	26	1040	1300	1560	1820	2080	2340	2600	2860	3250	3900	3900
50	47	1840	2300	2760	3220	3680	4140	4600	5060	5750	6900	7050
60	55.5	2220	2780	3330	3890	4440	5000	5550	6110	6940	8300	8300
68	88.5	3540	4430	5310	6200	7080	7970	8850	9740	11100	12500	12500 <sup>(4)</sup>
80	88.5	3540	4430	5310	6200	7080	7970	8850	9740	11100	13200	13200
100	130.5	5220	6530	7830	9140	10440	11700	13100	14400	16300	19500	19500
130	221.5	8860	11100	13300	15500	17700	19900	22200	24300	X	X	25000

X—Indicates where the listed supply pressure will exceed the maximum thrust allowable.  
 1. The maximum design pressure for size 25 through 100 actuators is 10.3 bar (150 psig). The size 68 and 130 actuators are limited to 9.7 and 7.8 bar (140 and 113 psig) respectively.  
 2. The size 25 and 50 data is for the construction without a bias spring.  
 3. Minimum operating pressure for sizes 60-130 actuators is 2.4 bar (35 psig).  
 4. The size 68 actuator with a handwheel is limited to 40000 Newtons (9000 lb) thrust.

# 585C Actuator

Table 13. Type 585C Long-Stroke Thrust

PISTON DIAMETER	STROKE	PISTON ROD SIZE	PISTON AREA	TOTAL THRUST FOR TYPE 585C LONG-STROKE ACTUATORS <sup>(1)</sup>						
				Operating Pressure, bar						
				2.8	4.1	5.5	6.9	8.3	9.7	10.3
mm		mm	mm <sup>2</sup>	Force, Newtons						
127	Push	---	127	3500	5250	6980	8720	10500	12200	13100
152			182	5030	7560	10100	12600	15100	17600	18900
203			323	8940	13400	17900	22400	26800	31300	33500
254			507	14000	21000	27900	34900	41900	48900	52500
305			730	20100	30200	40300	50300	60500	70300	75600
356			993	27400	41100	54700	68500	82300	96100	103000
127	Pull	44.5	111	3060	4580	6140	7650	9210	10700	11500
152			167	4580	6890	9210	11500	13800	16100	17300
203			309	8500	12800	17000	21300	25500	29800	31900
254			491	13600	20300	27100	33900	40700	47600	50700
203	Pull	63.5	293 <sup>(2)</sup>	8050	12100	16100	20200	24200	28200	30200
254			475 <sup>(3)</sup>	13100	19700	26200	32700	39300	45800	48900
305			698	19300	28900	38500	48000	57800	67200	72100
356			961	26500	39800	52900	66300	79600	93000	99600
PISTON DIAMETER	STROKE	PISTON ROD SIZE	PISTON AREA	Operating Pressure, psig						
Inches		Inches	Inches <sup>2</sup>	40	60	80	100	120	140	150
				Force, Pounds						
5	Push	---	19.6	786	1180	1570	1960	2360	2750	2950
6			28.3	1130	1700	2260	2830	3390	3960	4240
8			50.3	2010	3020	4020	5030	6030	7040	7540
10			78.5	3140	4710	6280	7850	9420	11000	11800
12			113.1	4520	6790	9050	11300	13600	15800	17000
14			153.9	6160	9240	12300	15400	18500	21600	23100
5	Pull	1.75	17.2	689	1030	1380	1720	2070	2410	2580
6			25.9	1030	1550	2070	2590	3100	3620	3880
8			47.9	1910	2870	3830	4790	5740	6700	7180
10			76.1	3050	4570	6090	7610	9140	10700	11400
8	Pull	2.5	45.4 <sup>(2)</sup>	1810	2720	3630	4540	5440	6350	6800
10			73.6 <sup>(3)</sup>	2950	4420	5890	7360	8840	10300	11000
12			108.2	4330	6490	8660	10800	13000	15100	16200
14			149.0	5960	8940	11900	14900	17900	20900	22400

1. For operating pressures above 10.3 bar (150 psig), consult your Emerson Process Management sales office.  
 2. For travels greater than 406 mm (16 inches) with 10.3 to 17.3 bar (150 to 250 psig) operating pressure.  
 3. For travels greater than 406mm (16 inches).

## Principle of Operation

The Type 585C piston actuator (figures 2 and 3) uses a piston that moves inside the actuator cylinder. An O-ring (see figure 3) provides a seal between the piston and the cylinder.

From an equilibrium state, the actuator reacts to a force unbalance that is created by increasing supply pressure on one side of the piston, and decreasing it on the other. This moves the piston up or down, and results in a repositioning of the valve control element.

## Actuator with Handwheel (figures 2 and 6)

The handwheel version can be used to open or

close the valve manually (either during normal operation or in an emergency), to position the valve at any point in the stroke, or to act as a travel stop.

Size 25 and 50 actuators use an integral top-mounted handwheel. See figure 6.

Size 60 to 130 actuators use a side-mounted handwheel, and come with a spring-loaded ball detent which prevents vibration from changing the handwheel setting. Handwheels for most types are either 203 mm (8 inches) in diameter with beveled gears or 432 mm (17 inches) in diameter with worm gears.

## Handwheel Specifications

Table 14. Type 585C Handwheel Specifications

ACTUATOR SIZE	HANDWHEEL MOUNTING	HANDWHEEL DIAMETER	TURNS PER mm TRAVEL	MAXIMUM RIM FORCE REQUIRED	HANDWHEEL OUTPUT FORCE	HANDWHEEL WEIGHT
		mm		Newtons	Newtons	kg
25	Top-Mounted	356	0.5	325	12,810	17
50		482	0.5	445	23,790	20
60	Integral Side-Mounted	203	0.6	276	40000	28
68		203	0.6	276	40000	30
80		432	0.4	423	50000	35
100		432	0.4	623	75600	94
130		432	0.4	623	75600	123
ACTUATOR SIZE	HANDWHEEL MOUNTING	HANDWHEEL DIAMETER	TURNS PER INCH TRAVEL	MAXIMUM RIM FORCE REQUIRED	HANDWHEEL OUTPUT FORCE	HANDWHEEL WEIGHT
		Inches		Pounds	Pounds	Pounds
25	Top-Mounted	14	12	73	2880	37
50		19	12	100	5350	45
60	Integral Side-Mounted	8	16	62	9000	61
68		8	16	62	9000	66
80		17	10	95	11250	77
100		17	10	140	17000	208
130		17	10	140	17000	272

### Actuator with Spring Return (figure 3)

Type 585C size 25 & 50 actuators are available with bias springs in two configurations. The Type 585C actuator, with the bias spring under the piston, fully retracts the actuator stem upon loss of cylinder pressure. The Type 585C actuator, with the bias spring on top of the piston, fully extends the actuator stem upon loss of cylinder pressure. No additional parts are required to convert from one actuator type to the other.

### Type 585C Long-Stroke Construction

When especially high thrust or long stroke is required, the Type 585C Long-Stroke piston actuator is the answer (see figure 4). The versatility of the Long-Stroke version allows accommodation of 16 different valve travels, up through 610 mm (24 inches). Available thrusts are impressive too, with thrust capability of up to 137,800 newtons (30,800 lbs).

For more detailed information on the Type 3610 positioner and DVC6000 digital valve controllers, refer to the Principle of Operation section in the Type 3610 and DVC6000 Instruction Manuals.

### Installation



#### WARNING

**Always wear protective gloves, clothing, and eyewear when performing any installation operations to avoid personal injury.**

**To avoid personal injury or property damage caused by bursting of pressure-retaining parts, be certain the cylinder pressure or other pressure ratings do not exceed the limits listed in tables 1 and 2. Use pressure-limiting or pressure-relieving devices to prevent cylinder pressure or other pressure ratings from exceeding these limits.**

**Check with your process or safety engineer for any additional measures that must be taken to protect against process media.**

**If installing into an existing application, also refer to the WARNING at the beginning of the Maintenance sections in this instruction manual.**

When an actuator and valve are shipped together as a control valve assembly, the actuator is normally

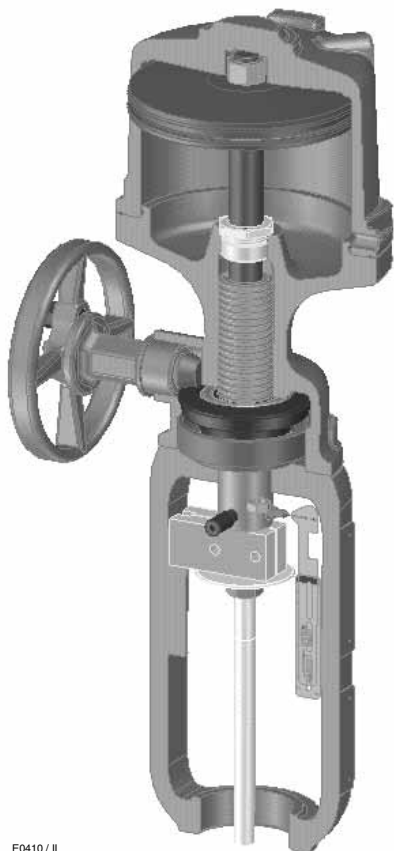

Figure 2. Type 585C Piston Actuator with Handwheel

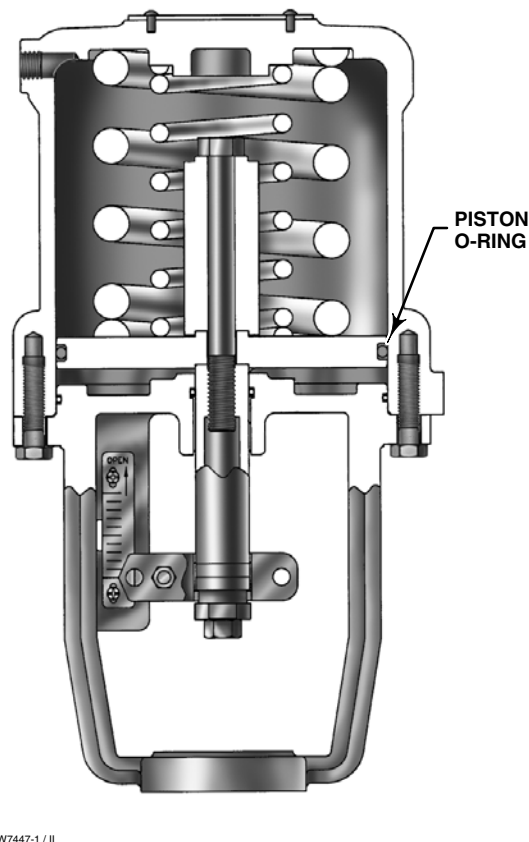

Figure 3. Type 585C Piston Actuator with Spring Return

mounted on the valve. Follow the valve instructions when installing the control valve in the pipeline. If the actuator is shipped separately or if it is necessary to mount the actuator on the valve, perform the Actuator Mounting procedures in this instruction manual corresponding to your actuator size. For information on mounting valve positioners, refer to the 3610 or DVC6000 instruction manuals for details.

If a Type 585C actuator is being installed without a positioner, the cylinder loading pressures should be supplied through a 4-way solenoid valve or a switching valve. The bottom side of the piston is pressured through the bottom side of the mounting flange on the actuator yoke (key 6, figures 5 and 7) for sizes 25 and 50 or the connection at the lower side of the cylinder (key 1, figure 10 to 13) for sizes 60 to 130. The top side of the piston is pressured through the connection in the cylinder cover (key 1 for figures 5, 7; and 10 to 13).

The supply pressure medium should be clean, dry filtered air. If the supply source is capable of exceeding the maximum actuator operating pressure or positioner supply pressure, appropriate steps must be taken during installation to protect the positioner and all connected equipment against overpressure.

## WARNING

**Dropping the actuator and any attached accessories and/or valve may cause personal injury and/or equipment damage. For all mounting procedures use an adequately sized chain, sling, hoist, or crane to handle the actuator and any attached accessories and/or valve. Use caution during lifting and handling to prevent**



W2795-1/1L

Figure 4. Type 585C Long-Stroke Actuator

**slippage, swinging, faulty equipment connections, or sudden shock loads.**

### CAUTION

**To avoid damage to actuator parts and difficult operation of actuator handwheels, open the bypass valve before using a handwheel.**

If manual operation is required, the actuator should be equipped with a manual handwheel. To manually move the piston rod with the handwheel, first open

the bypass needle valve (key 66 for sizes 25 and 50, figure 9; key 92 for sizes 60 to 130, figure 14), place the handwheel pointer in the neutral position, and insert the locking pin in the sleeve assembly (for size 60-130 and long-stroke). Then turn the handwheel in the selected direction as indicated on the wheel.

The control valve should be located where it will be accessible for servicing. Room should be left above and below the control valve to permit removal of the actuator and valve plug.

### Bypass Assembly

The bypass is furnished as shown in figures 6, 8, 9, 14, and 16 only when a handwheel actuator is specified. The bypass allows the pressure to equalize on either side of the piston, so that the manual actuator can be used to position the valve.

Flow through the bypass tubing is controlled by an angle needle valve (key 66 for figures 6, 8, and 9; key 92 for figure 14; and key 54 for figure 16), which is operated manually. This valve should be closed when air pressure is being used to operate the valve.

### Three-Way Valve Applications Note

#### WARNING

**To avoid loss of control of process fluid and subsequent personal injury or property damage caused by bursting of pressure-retaining parts, be sure the cylinder pressure does not exceed 80 psig in high cycle-rate, fast stroking speed, three-way valve applications.**

In three-way valve applications where the actuator fully strokes at a frequency of once per minute or faster, and the stroking speed is rapid (less than 0.5 seconds per stroke), there is a possibility that the stem can fracture at the plug if the actuator cylinder pressure is greater than 80 psig. This can cause loss of control of process fluid and further damage to the actuator. Consideration should be given to the use of high-strength, fatigue-resistant stem materials in these applications.

# 585C Actuator

## Actuator Mounting

### Size 25 and 50 Actuator Mounting

The following procedure describes how to mount a Type 585C actuator size 25 and 50 on a push-down-to-close valve so that the piston stem to valve plug stem connection allows full travel and proper shutoff. Key numbers referenced in the following steps are shown in figures 5 through 9.

1. If not already removed, remove the stem connector (key 12) by loosening the cap screws (key 14).
2. Thread the stem connector nuts (keys 13 and 15) onto the valve stem, and run the nuts to the bottom of the valve stem threads.
3. Push the valve plug stem until the valve plug is closed for push-down-to-close valve plug action.
4. Place the actuator on the bonnet of the valve and secure the actuator tightly to the bonnet with the yoke locknut.

(figures 5 and 6) on a push-down-to-close valve, manually move the valve plug to the seated position. Rotate the handwheel or apply pressure to the pressure connection in the cylinder (key 1) until the piston (key 3) and actuator stem (key 10) move down the specified travel. Run the stem connector nut (key 13) up on the valve stem until it contacts the actuator stem. Back off the handwheel or reduce cylinder pressure enough to move the actuator stem away from the stem connector nut approximately 1/4 inch. Rotate the stem connector nut, so it moves up the valve stem, an additional two turns. Rotate the handwheel or apply pressure to the pressure connection in the cylinder (key 1) until the actuator stem (key 10) again contacts the stem connector nut. Be sure the flats on the actuator stem are perpendicular to the scale indicator web on the yoke (key 6). Adjust the stem connector nut as necessary, so that the flats on the nut and the actuator stem are parallel. Clamp the actuator stem and stem connector nut together with the stem connector (key 12) and the two cap screws and hex nuts (keys 14 and 23). Run the hex nut (key 15) up the valve stem and tighten against the stem connector nut (key 13).

### CAUTION

**In the following procedure, do not rotate the valve plug while it is seated since this may cause damage to the seating surface and thereby allow excessive leakage. Also, during adjustment, use tools carefully to avoid damaging the valve plug stem. A damaged valve plug stem could cut the packing and allow leakage.**

#### Note

**When using an actuator with handwheel in the following step to stroke the valve plug, be sure the bypass valve (key 66, figure 6, 8, or 9) is open. Rotating the handwheel (key 47, figure 6, 8, or 9) clockwise extends the actuator stem (key 10); rotating the handwheel counterclockwise retracts the actuator stem.**

5. Perform one of the following procedures (a or b as appropriate):
  - a. **For a Type 585C actuator with spring retraction upon loss of cylinder pressure**

b. **For a Type 585C actuator with spring extension upon loss of cylinder pressure (figures 7 and 8) with push-down-to-close valve**, manually move the valve plug to the seated position. Run the stem connector nut (key 13) up the valve stem until it contacts the actuator stem (key 10). Rotate the handwheel or apply pressure to the pressure connection in the yoke (key 6) to move the actuator stem (key 10) approximately 1/4 inch away from the stem connector nut. Rotate the stem connector nut so that it moves up the valve stem two full turns. Manually move the valve plug so that the stem connector nut again contacts the actuator stem. Be sure the flats on the actuator stem are perpendicular to the scale indicator web on the yoke (key 6). Adjust the stem connector nut, as necessary, so that the flats on the nut and the actuator stem are parallel. Clamp the actuator stem and stem connector nut together with the stem connector (key 12) and the two cap screws and hex nuts (keys 14 and 23). Run the hex nut (key 15) up the valve stem and tighten it against the stem connector nut (key 13).

6. Cycle the actuator several times to check for proper operation.

**Note**

**In the following step, make sure the correct travel indicator scale (key 19) is used per the Parts List for the desired travel.**

7. If necessary, remove the travel indicator scale screws (key 18) and reposition the travel indicator scale (key 19) so that the scale arrow points in the same direction as the valve plug moves when opening. Close the valve. Adjust the scale up or down so that the stem connector (key 12) indicator lines up with the closed mark on the scale. Secure the scale with the scale screws.

**Size 60-130 Actuator Mounting**

The following procedure describes how to mount a Type 585C size 60 to 130 actuator on a push-down-to-close valve so that the piston stem to valve plug stem connection allows full travel and proper shutoff. Key numbers referenced in the following steps are shown in figures 10 through 13.

If an actuator is purchased separately for field installation on a control valve, mount it on the valve and secure it in place with the yoke locknut for size 60 and 68 or with eight bolts on actuator sizes 80, 100, and 130 which use a 127 mm (5-inch) yoke boss.

The stem connector should then be set up to clamp the actuator stem and valve plug stem together to provide the proper valve travel. This procedure is outlined in the Stem Connector Assembly procedures of this instruction manual.

**Stem Connector Assembly (Size 60-130)**

**CAUTION**

- **To avoid damaging the seating surfaces, do not rotate the valve plug while it is seated. Also avoid damage to the valve plug stem by careful use of tools during travel adjustment.**
- **Incomplete engagement of valve stem and/or actuator stem in the stem connector can result in stripped threads or improper operation. Be sure that the length of each stem clamped in the stem connector is equal to or**

**greater than the diameter of that stem. Do not loosen the cap screws when the stem connector has spring or loading pressure force applied to it.**

 **WARNING**

**To avoid personal injury or property damage, keep hands and tools out of the actuator stem travel path while pressuring the actuator to move the actuator stem in the following steps.**

**585C Size 60-130 Direct-Acting (Push-Down-to-Close) Valves**

1. With the valve assembled and the actuator mounted, make sure the valve plug is in the closed position, and the actuator is at the top of its stroke. Then screw the two stem locknuts (key 15) all the way onto the stem thread and place the travel indicator disk (key 32) (if any) on the stem locknuts.
2. Keeping your hands away from any moving parts, pressure the actuator until the actuator stem (key 10) moves down from the top of its stroke the specified valve travel.
3. Attach the stem connector (key 12), clamping the actuator stem to the valve stem. With the stem locknuts (key 15), raise the travel indicator disk (key 32) to the stem connector (key 12).
4. Cycle the actuator to check availability of desired total travel and that the valve plug seats before the actuator contacts the lower travel stop. Minor travel adjustments can be made by loosening the stem connector (key 12) slightly, tightening the locknuts (key 15) together, and screwing the valve stem either into or out of the stem connector (key 12) with a wrench on the locknuts (key 15). If the valve stem cannot be turned, as with a bellows seal bonnet, remake the stem connection to achieve the desired travel.
5. Once the total travel is adequate, tighten the stem connector (key 12) securely, lock the stem locknuts (key 15) against the connector, and adjust the indicator scale (key 19) on the yoke to show correct valve plug position.
6. Provide a gauge to measure the pressure to the actuator. Make a final adjustment of the actuator or its positioner to set the starting point of valve travel and to obtain full travel for the given instrument range.

# 585C Actuator

## 585C Size 60-130 Reverse-Acting (Push-Down-to-Open) Valves

1. Keeping your hands away from moving parts, pressure the actuator to move the actuator stem (key 10) to the extreme upward position then reverse loading pressure to lower the actuator stem (key 10) approximately 3 mm (1/8 inch).
2. Pull the valve stem up to seat the valve plug.
3. With the two cap screws, attach the stem connector (key 12) to the actuator stem (key 10) and valve stem making sure the stem connector (key 12) fully engages the actuator stem threads.
4. If there is a travel indicator disk (key 32), raise it to the stem connector (key 12) and tighten in position with the stem locknuts (key 15). The indicator disk (key 32) should show the valve to be open with the piston (key 3) at the bottom of its stroke. If it does not, loosen two screws (key 18) and shift the travel indicator scale (key 19) to indicate OPEN.
5. Cycle the actuator to check availability of desired total travel and that the valve plug seats before the actuator contacts the upper travel stop. Minor travel adjustments can be made by loosening the stem connector (key 12) slightly, tightening the locknuts (key 15) together, and screwing the valve stem either into or out of the stem connector (key 12) with a wrench on the locknuts. If the valve stem cannot be turned, as with a bellows seal bonnet, remake the stem connection to achieve the desired travel.
6. Once the total travel is adequate, tighten the stem connector (key 12) securely, lock the stem locknuts (key 15) against the connector, and adjust the indicator scale (key 19) on the yoke to show correct valve plug position.
7. Provide a gauge to measure the pressure to the actuator. Make a final adjustment of the actuator or its positioner to set the starting point of valve travel and to obtain full travel for the given instrument range.

## Long-Stroke Actuator Mounting

The following procedure describes how to mount a Type 585C Long Stroke actuator on a push-down-to-close valve so that the piston stem to valve plug stem connection allows full travel and

proper shutoff. Key numbers referenced in the following steps are shown in figures 15 and 16.

If you purchase a 585C Long Stroke actuator for field installation on a control valve, mount the actuator on the valve and secure it to the bonnet with the eight bonnet-to-actuator bolts. The stem connection should then be made up to clamp the actuator stem and valve plug stem together to provide proper valve travel.

### CAUTION

**To avoid damaging the seating surfaces, do not rotate the valve plug while it is seated. Avoid damage to the valve plug stem by careful use of tools during travel adjustments.**

1. With the valve assembled and actuator mounted, make sure the valve plug is in the closed position. Then turn the two stem locknuts (key 23) all the way onto the stem thread.
2. Starting with the cylinder fully retracted, manually or with air pressure extend the piston rod extension the specified valve travel.
3. Attach the stem connector (key 22), clamping the piston rod extension to the valve stem. Be sure you also attach the feedback arm and travel indicator (key 3).
4. Cycle the actuator to check availability of desired total travel and that the valve plug seats before the cylinder reaches the end of its stroke. You can make minor travel adjustments, if necessary, by loosening the stem connector slightly, tightening the locknuts together, and (with the valve plug off the seat) screwing the stem either into or out of the stem connector by means of a wrench on the locknuts.
5. If the total travel is adequate, tighten the stem connector (key 22) securely, lock the stem locknuts (key 23) against the connector, and adjust the indicator scale (key 7) on the yoke (key 1) to show valve plug position.
6. Provide a gauge, if necessary, to measure the pressure to the actuator. Make a final adjustment on the positioner to set the starting point of valve travel and to obtain full travel for the given instrument range.

## Type 585C Handwheels

### Handwheel Operation (Sizes 25 & 50)

Key numbers referenced in the following steps are shown in figures 6, 8, and 9 for the Type 585C actuator.

The handwheel assembly on a Type 585C actuator may be used as an adjustable travel stop to limit full upward or downward travel of the actuator stem (key 10), or as a manual actuator to fully stroke the valve. When the neutral indicator (key 42) is in the neutral position, travel is not restricted. With clockwise handwheel (key 47) rotation, the operating nut (key 46) is screwed downward, forcing the actuator stem (key 10) down. With counterclockwise rotation, the operating nut is screwed upward against the handwheel stem washer (key 45), pulling the actuator stem up.

#### Note

**When using an actuator with handwheel to stroke the valve plug or position the travel stop, be sure the bypass valve (key 66) is open.**

### Handwheel Operation (Sizes 60-130)

The Type 585C handwheel assembly for sizes 60 through 130 actuators (figures 10 and 11) has three main functions:

- a. To open or close the valve manually or to position the valve at any point in the stroke, regardless of the cylinder pressure. The tapered pin is inserted during manual throttling operation.
- b. To act as a travel stop to limit full opening or closing of the valve but not both at the same time. The tapered pin is left out when the assembly is used as a travel stop.
- c. To open or close the valve manually in an emergency without the necessity of inserting the tapered pin.

Bevel gears are used in sizes 60 and 68 and worm gears in sizes 80 through 130. A spring-loaded ball detent is provided in the handwheel to prevent a change in setting due to vibration. The following table lists pertinent information on these handwheel units.

Actuator Size	60-68	80-130
Handwheel Diameter, Inches	8	17
Turns Required for One Inch of Travel	16	10

### Long-Stroke Handwheel Operation

Key numbers referenced in the following steps are shown in figures 15 and 16 for the Type 585C long-stroke actuator.

With the pointer (key 42) in the neutral position, automatic operation is possible throughout full travel. The locking pin (key 10) should be left out during automatic operation, and the needle valve (key 54) must be closed.

For manual operation, the locking pin (key 10) must be inserted into the hole in the sleeve assembly before you open the needle valve (key 54). Rotation of the handwheel (key 32) in either direction causes the valve stem to move because of the pinned connection between the piston rod extension and sleeve. There is a directional arrow and the word "OPEN" cast on the handwheel to indicate the rotation required to open the valve. To shift from manual to automatic operation, return the handwheel pointer (key 42) to the neutral position, close the needle valve (key 54), and remove the tapered pin (key 10).

The handwheel assembly can provide a travel stop to restrict upward travel of the valve plug. When you set the travel stop, the tapered pin (key 10) should be left out. As an example, consider the control valve with a push-down-to-close valve plug action. To restrict full opening, turn the handwheel (key 32) to lower the sleeve assembly (key 9). In normal operation, as the valve opens, the stem connector (key 22) contacts the lower part of the sleeve before full valve travel is reached. You can note the amount of restriction on the travel scale (key 7).

#### Note

**If an emergency arises, you can close the valve (push-down-to-close) quickly without inserting the pin into the sleeve assembly. First, turn the handwheel to move the sleeve against the stem connector (key 22), then open the needle valve and turn the handwheel to force the valve plug closed.**

### Maintenance (Sizes 25 & 50)

Actuator parts are subject to normal wear and must be inspected and replaced as necessary. The

# 585C Actuator

frequency of inspection and replacement depends on the severity of service conditions. This section provides two separate procedures, one on Replacing Handwheel Housing O-Ring or Thrust Bearings, and the other on Replacing Seals, Changing Action, or Changing Bias Spring(s).

Refer to figures 6 and 8.

For an actuator with handwheel, a grease fitting (key 50) is provided on the bearing cover (key 38) for periodic bearing lubrication with lithium grease (key 24).



## WARNING

**Avoid personal injury from sudden release of process pressure. Before performing any maintenance operations:**

- Always wear protective gloves, clothing, and eyewear when performing any maintenance operations to avoid personal injury.
- Disconnect any operating lines providing air pressure, electric power, or a control signal to the actuator. Be sure the actuator cannot suddenly open or close the valve.
- Use bypass valves or completely shut off the process to isolate the valve from process pressure. Relieve process pressure on both sides of the valve. Drain the process media from both sides of the valve.
- Vent the power actuator loading pressure and release all bias spring compression force by slowly unscrewing the cylinder cover bolting in a crisscross pattern.
- Use lock-out procedures to be sure that the above measures stay in effect while you work on the equipment.
- The valve packing box may contain process fluids that are pressurized, *even when the valve has been removed from the pipeline.* Process fluids may spray out under pressure when removing the packing hardware or packing rings, or when loosening the packing box pipe plug.

- **Check with your process or safety engineer for any additional measures that must be taken to protect against process media.**

## Replacing Handwheel Housing O-Ring or Thrust Bearings (Sizes 25 & 50)

Perform this procedure if inspecting or replacing the handwheel housing O-ring, handwheel thrust bearings, or any other handwheel parts located above the cylinder (key 1). Inspection or replacement of the cylinder O-ring, handwheel stem, or handwheel stem jam nut (key 57, 56, or 52) are covered in the Replacing Seals, Changing Action, or Changing Bias Spring(s) procedure. Key numbers are referenced in figure 6 for a Type 585C actuator (spring retracts actuator rod) and in figure 8 for a Type 585C actuator (spring extends actuator rod).

### Note

**This procedure may be performed without removing the cylinder, or yoke (key 1 or 6) from the bonnet of the valve.**

## Disassembly

Isolate the control valve from the line pressure, release pressure from both sides of the valve body, and drain the process media from both sides of the valve. Shut-off all pressure lines and power to the actuator, and release all pressure from the actuator. Use lock-out procedures to be sure that the above measures stay in effect while you work on the equipment.



## WARNING

**Refer to the WARNING at the beginning of the Maintenance section in this instruction manual.**

1. Shut off the bypass valve (key 66). Remove the cylinder pressure piping and bypass tubing from the bypass tees (key 68) on the cylinder (key 1).
2. Turn the handwheel (key 47) in the appropriate direction so the neutral indicator (key 42) is behind the NEUTRAL position of the neutral indicator plate (key 37).
3. Unscrew and remove the neutral indicator cover (key 35).
4. Remove the handwheel retaining ring, handwheel, and locking key (keys 48, 47, and 65).

5. Loosen the bearing cover set screws (key 51), and unscrew and carefully remove the bearing cover (key 38).
6. Remove the handwheel housing O-ring (key 58) and the top set of thrust bearings (key 39).
7. Since both the handwheel housing (key 36) and the operating nut (key 46) have left-hand threads, unscrew the handwheel housing by turning it clockwise off the operating nut. Carefully remove the detent ball and detent spring (keys 64 and 63), and remove the bottom set of thrust bearings (key 39).
8. Unscrew the handwheel stem cap screw (key 60) while using a 7/8 inch wrench to hold the handwheel stem (key 56). Remove the handwheel stem washer (key 45), and the operating nut (key 46) with attached neutral indicator (key 42).
9. Unscrew the neutral indicator (key 42) counterclockwise if necessary to separate it from the operating nut (key 46).

### Reassembly

1. If the neutral indicator (key 42) was removed, coat its threads with thread locking adhesive (medium strength) (key 70) and screw it into the operating nut (key 46). Position the 90-degree elbow of the neutral indicator so that it will not interfere with the neutral indicator cover (key 35) when assembled.
2. If necessary, replace the anti-rotation key (key 40), by pushing the key outward from the cylinder (key 1) then install the replacement key (key 40) into the anti-rotation hole of the cylinder.
3. Lubricate the inside surface of the operating nut (key 46) with lithium grease (key 24). Install the operating nut with the attached neutral indicator, and the handwheel stem washer (key 45), onto the handwheel stem (key 56) and secure with the handwheel stem cap screw (key 60). Tighten the cap screw to 169 N•m (125 lbf•ft).
4. Place the bottom set of thrust bearings (key 39) on top of the cylinder (key 1). Insert the detent spring and ball (keys 63 and 64) into the cylinder.
5. Install the handwheel housing O-ring (key 58) on the handwheel housing (key 36). Since both the handwheel housing and the operating nut (key 46) have left-hand threads, thread the handwheel housing onto the operating nut by turning it counterclockwise over the operating nut until the handwheel housing is snug against the bottom set of thrust bearings (key 39).
6. Install the top set of thrust bearings (key 39) over the handwheel housing (key 36).
7. Carefully slide the bearing cover (key 38) over the handwheel housing (key 36) and thread the bearing cover hand tight onto the cylinder (key 1). Secure by tightening the set screws (key 51) to 18 N•m (13 lbf•ft).
8. Install the locking key, handwheel, and handwheel retaining ring (keys 65, 47, and 48).
9. Screw the neutral indicator cover (key 35) hand tight only onto the handwheel housing (key 36).
10. Install the bypass tubing with attached bypass valve (key 66) into the bypass tees (key 68) in the cylinder (key 1).

### Replacing Seals, Changing Action, or Changing Bias Spring(s) (Sizes 25 & 50)

Key numbers are referenced in figures 5 and 6 for a Type 585C actuator (spring retracts actuator rod) and in figures 7 and 8 for a Type 585C actuator (spring extends actuator rod).

### Disassembly

Isolate the control valve from the line pressure, release pressure from both sides of the valve body, and drain the process media from both sides of the valve. Shut-off all pressure lines and power to the actuator, release all pressure from the actuator, and release all bias spring compression force by slowly unscrewing the cylinder cover bolting in a crisscross pattern. Use lock-out procedures to be sure that the above measures stay in effect while you work on the equipment.

### WARNING

**Refer to the WARNING at the beginning of the Maintenance section in this instruction manual.**

For Type 585C actuators with push-only handwheel, figure 9, be sure the handjack stem is backed out of the cylinder as far as it will go to relieve any extra spring compression.

1. Remove the cylinder pressure piping. With a handwheel construction, perform steps 2 through 1 of the Replacing Handwheel Housing O-Ring or Thrust Bearings procedure.

# 585C Actuator

## Note

**In the following step, loosen each cylinder-to-yoke cap screw a slight amount in turn in a crisscross pattern to keep the cylinder square with the yoke while relieving spring precompression.**

2. While carefully allowing bias spring precompression to be slowly released, remove the cylinder-to-yoke cap screws and cylinder cover (keys 2 and 1).

## CAUTION

**When performing the following step, set the cylinder on a protective surface to prevent damage to the cylinder surfaces.**

3. Remove the cylinder (key 1). Set the cylinder on a protective surface to prevent damage to the cylinder surfaces. With a handwheel construction, inspect the cylinder O-ring (key 57) and replace it if necessary, applying lithium grease (key 24) to the replacement O-ring.
4. Inspect the piston O-ring (key 8) and replace, if necessary. If the only further maintenance to be performed is replacement of the piston O-ring, skip to step 3 of this procedure.

## Note

**Type 585C actuators may be used with or without the bias springs. In the following procedures, references are made to the bias springs. If the bias springs are not used, disregard references to them when performing the maintenance procedures.**

5. Perform one of the following disassembly procedures (a, b, c, d, or e, as appropriate):
  - a. **For Type 585C actuators without handwheel (If the bias spring is present, it extends the piston rod.) (figure 7)**, remove the piston cap screw (key 4), piston (key 3), bias spring(s) (key 16 and/or key 17), and travel stop spacer (key 5).
  - b. **For Type 585C actuators with handwheel (If the bias spring is present, it extends the piston rod.) (figure 8)**, remove the handwheel stem (key 56) with attached piston stud (key 69),

piston (key 3), bias spring(s) (key 16 and/or key 17), and travel stop spacer (key 5).

- c. **For Type 585C actuators without handwheel (If the bias spring is present, it retracts the piston rod.) (figure 5)**, remove the bias spring(s) (key 16 and/or key 17), piston cap screw (key 4), travel stop spacer (key 5) and piston (key 3).
- d. **For Type 585C actuators with handwheel (If the bias spring is present, it retracts the piston rod.) (figure 6)**, remove the bias spring(s) (key 16 and/or key 17), the handwheel stem (key 56) with attached piston stud (key 69), travel stop spacer (key 5), and piston (key 3).

- e. **For Type 585C actuators with push-only handwheel (figure 9)**, remove the cotter pin and slotted nut (keys 73 and 72) and lift off the handwheel. Remove the jam nut (key 52). Remove the cap screws (key 60) and lift off the handwheel housing (key 36). Back the handwheel stem (key 56) out of the housing. Inspect the O-rings (keys 57 and 58). Replace these parts as necessary.

6. If inspection or replacement of the actuator stem O-ring or bearing (key 9 or 11) is necessary, perform steps 7 through 1. Otherwise skip to step 2, being sure to comply with the note preceding step 2.
7. Loosen the two cap screws in the stem connector (key 14) and remove it. If the actuator is mounted on a valve, separate the actuator stem (key 10) from the valve plug stem. Remove the actuator from the valve.
8. To inspect the actuator stem bearing (key 11), actuator stem O-ring (key 9), or backup ring (key 25, size 50 only) remove the actuator stem (key 10) from the yoke (key 6). Replace these parts if necessary. Apply lithium grease (key 24) to the replacement O-ring or bearing and install it into the yoke.

## Assembly

1. Install the actuator stem through the yoke.

## Note

**Make certain the travel indicator scale (key 19) correctly matches the travel per the Parts List.**

2. To achieve the desired construction (either a direct-acting or a reverse-acting Type 585C actuator), perform one of the following assembly procedures (a, b, or c, as appropriate):

a. **For Type 585C actuators (bias spring extends the piston rod) (figures 7 and 8)**, center the inner bias spring, if used, (key 17 per table 10 or 11) around the center boss in the yoke (key 6). If used per table 10 or 11, center the outer bias spring (key 16) around the inner bias spring. The outer bias spring should be within the outer boss in the yoke. Put the travel stop spacer and the piston (keys 5 and 3) on the actuator stem. Apply lithium grease (key 24) to the threads of the piston cap screw or piston stud (key 4 or 69). Insert the piston cap screw, or stud plus attached handwheel stem (key 56), through both the piston and travel stop spacer and into the actuator stem. Use a wrench on the flats of the actuator stem to prevent it from turning. Tighten the piston cap screw, or stud plus attached handwheel stem, to 102 N•m (75 lbf•ft) for size 25 actuators or 136 N•m (100 lbf•ft) for size 50 actuators.

b. **For Type 585C actuators with push-only handwheel (figure 9)**, lubricate the O-rings and handjack stem threads with lithium grease. Install the O-ring (key 57) and handjack stem (key 56), turning the screw into the housing as far as possible. Place the O-ring (key 58) over the housing and insert into the cylinder (key 1). Replace the cap screws (key 60) and tighten to 41 N•m (30 lbf•ft) on size 25 actuators or 81 N•m (60 lbf•ft) on size 50 actuators. Replace the jam nut (key 52), handwheel (key 47), and slotted nut and cotter pin (keys 72 and 73).

c. **For Type 585C actuators (bias spring retracts the piston rod) (figures 5 and 6)**, put the piston (key 3) on the actuator stem and the travel stop spacer (key 5) on the piston. Apply lithium grease (key 24) to the threads of the piston cap screw or piston stud (key 4 or 69). Insert the piston cap screw, or stud plus attached handwheel stem (key 56), through both the travel stop spacer and piston and into the actuator stem. Use a wrench on the flats of the actuator stem to prevent it from turning. Tighten the piston cap screw, or stud plus attached handwheel stem, to 102 N•m (75 lbf•ft) for size 25 actuators or 136 N•m (100 lbf•ft) for size 50 actuators. Center the inner bias spring, if used, (key 17 per table 8 or 9) around the travel stop spacer. If used per table 8 or 9, center the outer bias spring (key 16) around the inner bias spring. The outer bias spring should be within the outer boss on the piston.

3. Install the piston O-ring (key 8) if it was removed from the piston, and the yoke O-ring (key 7, figure 5 or 7) if it was removed from the yoke (key 6). Apply lithium grease (key 24) to the wall of the cylinder (key 1) and carefully slide the cylinder over the piston O-ring. Be sure the cylinder pressure connection is aligned with the yoke pressure connection. Square the cylinder in place over the yoke O-ring.

4. Line up the cylinder holes with the yoke holes making sure for a handwheel construction that the anti-rotation groove in the handwheel stem (key 56) is aligned with the hole in the cylinder for the anti-rotation key (key 40).

**Note**

**When placing the cylinder on the yoke and tightening the cylinder-to-yoke bolts, be sure to keep the cylinder square and aligned with the top of the yoke.**

5. Lubricate the cylinder-to-yoke bolts (key 2) with lithium grease (key 24). In a criss cross pattern, alternately tighten each cylinder-to-yoke bolt a slight amount so that the cylinder stays square with the yoke. When all cylinder surfaces are in contact with the yoke, tighten each cylinder-to-yoke bolt to 70 N•m (55 lbf•ft) for a size 25 or 95 N•m (70 lbf•ft) for a size 50.

6. With a handwheel construction, perform steps 2 through 10 of the Replacing Handwheel Housing O-ring or Thrust Bearings procedure.

7. If the actuator will be mounted on a valve, perform the appropriate actuator mounting procedure. Otherwise, place the stem connector nut (key 13), stem connector (key 12), two cap screws (key 14), two hex nuts (key 23) and hex nut (key 15) in a parts bag and attach the bag to the actuator yoke.

**Maintenance (Sizes 60-130)**



**WARNING**

**Avoid personal injury from sudden release of process pressure or uncontrolled process fluid. Before starting disassembly:**

- Always wear protective gloves, clothing, and eyewear when

# 585C Actuator

performing any maintenance operations to avoid personal injury.

- **Disconnect any operating lines providing air pressure to the actuator. Be sure the actuator cannot suddenly open or close the valve.**

- **Use bypass valves or completely shut off the process to isolate the valve from process pressure. Relieve process pressure on both sides of the valve. Drain the process media from both sides of the valve.**

- **Vent the power actuator loading pressure.**

- **Use lock-out procedures to be sure that the above measures stay in effect while you work on the equipment.**

- **The valve packing box may contain process fluids that are pressurized, even when the valve has been removed from the pipeline. Process fluids may spray out under pressure when removing the packing hardware or packing rings, or when loosening the packing box pipe plug.**

- **Check with your process or safety engineer for any additional measures that must be taken to protect against process media.**

Key numbers indicated refer to figures 10 through 13.

Isolate the control valve from the line pressure, release pressure from both sides of the valve body, and drain the process media from both sides of the valve. Shut-off all pressure lines and power to the actuator, and release all pressure from the actuator. Use lock-out procedures to be sure that the above measures stay in effect while you work on the equipment.

1. If positioner is not used, go to step 5. If positioner is used, shut off all pressure lines to the positioner then remove all tubing lines (cylinder, instrument and supply) from the positioner.

## CAUTION

**Do not use wrenches or other tools directly on the valve stem. Damage to the stem surface could result in**

**subsequent damage to the valve packing.**

2. Remove the stem connector (key 12) and the piston rod boot (key 29) used to protect the lower end of the actuator stem.

3. Remove the socket head cap screws that hold the cylinder (key 1) to the yoke (key 6).

## CAUTION

**Exercise care in the following step to prevent damage to the cylinder wall during removal of the cylinder from the yoke.**

4. Insert a screwdriver in the two slots on the lower edge of the cylinder casting and pry the cylinder loose from the yoke. Remove the cylinder, being careful not to mar the cylinder wall.

5. The piston (key 3) and actuator stem (key 10) will come out with the cylinder. The piston can then be removed by forcing it out the open end of the cylinder.

6. Unscrew the seal bushing (key 110 or 26), in the upper end of the yoke (key 6).

7. With the unit disassembled, inspect all parts for excessive wear. Replace all worn O-rings. Lubricate (key 24) as indicated on the assembly drawings. Apply sealant (key 70) as indicated on the assembly drawings.

8. When reassembling the actuator after the piston nut (key 4) has been removed from the actuator stem (key 10), clean the threads of the piston nut thoroughly and apply thread sealant to the threads. Tighten the piston nut securely to a torque of 237 N•m (175 lbf•ft) for size 60 actuators, 1290 N•m (950 lbf•ft) for size 68, 80, and 100 actuators, or 2070 N•m (1530 lbf•ft) for size 130 actuators.

## Side-Mounted Handwheel Maintenance (Sizes 60-130)

Refer to figure 10 and 11.

1. The handwheel gears should be lubricated periodically. A grease fitting (key 140) is provided on sizes 80, 100, and 130. On sizes 60 and 68, remove the handwheel (key 118) and the bevel pinion (key 116) and pack the gear case with lithium grease. Loosen the set screw (key 139) before attempting to remove the pinion and extension.

2. If it is necessary to change the valve plug action from push-down-to-close to push-down-to-open or

vice versa, change the handwheel arrangement so that the arrow indicates the correct rotation required to open the valve.

- a. For sizes 60 and 68, remove the handwheel, invert and replace it. On sizes 60 and 68 (figure 10), remove and replace the spring-loaded ball assembly (key 123) in the opposite side.
- b. For sizes 80-100, remove the handwheel assembly and install in the opposite end of the gear case by unscrewing the back and front worm retainers (keys 135 and 136, not shown) and turn the handwheel to disengage the bevel pinion (key 116).

### ***Disassembly of Handwheel Constructions (Sizes 60 and 68)***

#### **WARNING**

**Refer to the WARNING at the beginning of the Maintenance section (Sizes 60-130) in this instruction manual.**

To disassemble Type 585C piston actuators sizes 60 and 68 (with handwheel) for maintenance, perform the following procedures (figure 10 and 11):

1. Be sure that all pressure is out of the cylinder and valve body.
2. Remove all tubing lines to the positioner.
3. Remove the cap screws (key 2) on the underside of either the cylinder flange (key 100) for size 60 or the adapter flange (key 76) for size 68. Remove the cylinder (key 1).
4. Remove the piston nut (key 4), then use a mallet to tap the piston (key 3) off the piston connector (key 107).
5. Remove the handwheel extension (key 117) by loosening the set screw (key 139) and unscrewing the extension.
6. Remove the cap screws (key 2) holding the cylinder flange (key 100) to the yoke (key 6).
7. Lift the cylinder flange (key 100) off the yoke (key 6).
8. Inspect the handwheel gears and bearings as needed.
9. To remove the actuator stem (not shown), loosen the stem connection (key 12) and pull the actuator stem out the top of the sleeve assembly (key 104).

10. Remove the sleeve by screwing it out of the sleeve assembly (key 104).

11. Unscrew the seal bushing (key 110) to inspect the O-rings (keys 9 and 27).

### ***Disassembly of Handwheel Constructions (Sizes 80-130)***

#### **WARNING**

**Refer to the WARNING at the beginning of the Maintenance section (Sizes 60-130) in this instruction manual.**

To disassemble Type 585C piston actuators sizes 80-130 (with handwheel) for maintenance, perform the following procedures (figure 11):

1. Be sure that all pressure is out of the cylinder and valve body.
2. Remove all tubing lines to the positioner.
3. Remove the cap screws (key 2) on the underside of the cylinder adapter (key 101) and remove the cylinder (key 1).
4. Remove the piston nut (key 4), then use a mallet to remove the piston (key 3) from the piston connector (key 107).
5. Remove the cap screws (key 127) and cylinder adaptor (key 101).
6. Remove the cap screws (key 128) and remove the spacer (key 102), being careful not to lose the key (key 144).
7. Remove the locking pin (key 131), disconnect the stem connector (key 12) and pull out the actuator stem.
8. Remove the pointer (key 129) and turn the sleeve out of the sleeve assembly (key 104).
9. Remove the cap screws (key 128) holding the gear case (key 103) to the yoke (key 6).
10. Lift the gear case (key 103) to expose the handwheel assembly.

### ***Reassembly (Sizes 60-130)***

When reassembling the Type 585C piston actuator with side-mounted handwheel, adjust the setscrew (key 125) to eliminate play in gear bearings. When properly set, lock with key 126.

When reassembling the actuator after the piston nut (key 4) has been removed from the piston connector (key 107), clean the threads of the piston nut

# 585C Actuator

thoroughly and apply thread sealant to the threads. Tighten the piston nut securely to a torque of 237 N•m (175 lbf•ft) for size 60 actuators, 1290 N•m (950 lbf•ft) for size 68, 80, and 100 actuators, or 2070 N•m (1530 lbf•ft) for size 130 actuators.

## Type 585C Long-Stroke Maintenance

Instructions are given below for complete disassembly of the actuator. When inspection or repair is necessary, disassemble the actuator only as far as is required to accomplish the job.

### WARNING

**Avoid personal injury from sudden release of process pressure or uncontrolled process fluid. Before starting disassembly:**

- Always wear protective gloves, clothing, and eyewear when performing any maintenance operations to avoid personal injury.
- Disconnect any operating lines providing air pressure to the actuator. Be sure the actuator cannot suddenly open or close the valve.
- Use bypass valves or completely shut off the process to isolate the valve from process pressure. Relieve process pressure on both sides of the valve. Drain the process media from both sides of the valve.
- Vent the power actuator loading pressure.
- Use lock-out procedures to be sure that the above measures stay in effect while you work on the equipment.
- The valve packing box may contain process fluids that are pressurized, *even when the valve has been removed from the pipeline.* Process fluids may spray out under pressure when removing the packing hardware or packing rings, or when loosening the packing box pipe plug.
- Check with your process or safety engineer for any additional measures

**that must be taken to protect against process media.**

## Non-Handwheel Construction

Key numbers used below are shown in the figure 15 assembly drawing.

1. Disconnect the cylinder tubing from the cylinder (key 11) and positioner.
2. Break the stem connection by loosening the two locknuts (key 23) and removing the four cap screws from the stem connector.

### Note

**Refer to the appropriate instruction manual for any maintenance or adjustments that need to be made on the positioner.**

3. You can remove the cylinder (key 11) by unscrewing the four cap screws (key 14) that fasten it to the yoke (key 1).

### Note

**Refer to the manufacturer's instruction manual for disassembly, maintenance and parts ordering instructions for the cylinder.**

4. Reassemble the actuator in the reverse order of the above instructions. Refer to the section Stem Connection Procedure to properly attach the valve stem to the cylinder rod extension.

## Handwheel Construction

Key numbers used below are shown in the figure 16 assembly drawing.

1. Disconnect the cylinder tubing (key 47) from the cylinder (key 11) and positioner.
2. Disengage the locking pin (key 10), if necessary. Then break the stem connection by loosening the two locknuts (key 23) and removing four cap screws from the stem connector (key 22).

### Note

**Refer to the appropriate instruction manual for any maintenance or adjustments that need to be made on the positioner.**

3. Unscrew the four cap screws (key 14) that fasten the cylinder (key 11) to the handwheel extension

(key 8). Then pull the cylinder, piston, and piston rod extension out of the sleeve (key 9).

4. Unscrew the piston rod extension from the cylinder piston rod using a wrench on the cylinder piston rod flats to keep the two from turning together.

**Note**

**Refer to the manufacturer's instruction manual for disassembly, maintenance and parts ordering instructions for the cylinder.**

5. To continue disassembly, remove the six cap screws (key 13) in order to take off the handwheel extension. Be careful not to lose the key (key 28).
6. Loosen the set screws (key 36) in the gear case (key 18) and handwheel cap (key 35). Unscrew the handwheel cap and remove the handwheel (key 32).
7. Unscrew the worm retainers (keys 29 and 30) and rotate the worm shaft (key 31) to remove it from the gear case.
8. Unscrew the cap screws (key 44) and remove the gear case.
9. One thrust bearing (key 20) is now exposed. To expose the other thrust bearing, unscrew the gear (key 19) from the sleeve (key 9).

**Note**

**The bearing retainer (key 21) sits on top of six set screws (key 27). If the gear case is just going to be repacked and no parts are changed which would change the free play in the bearings, you do not need to make any adjustment with the set screws.**

10. Upon reassembly, pack the bearings (keys 20 and 40) with lithium grease. Also apply lithium grease to the surfaces of the sleeve and the bearing surfaces of the worm shaft. Use the zerk fitting for periodic lubrication after assembly.
11. Reassemble in the reverse order of the above steps observing the following points:
  - a. Line up the key (key 28) with the slot in the sleeve.
  - b. After the unit is reassembled, adjust the set screws (key 27), if necessary, to eliminate free play in the bearings. Lock the set screws in place with the hex nuts (key 41).

**Note**

**Over-tightening the set screws will make handwheel operation difficult.**

**Stem Connection Procedure**

The following procedure is for a push-down-to-close valve. The objective of this procedure is that the stem connection must be made so that the valve strokes from full open to closed before the actuator reaches full stroke.

**CAUTION**

**To avoid damaging the seating surfaces, do not rotate the valve plug while it is seated. Avoid damage to the valve plug stem by careful use of tools during travel adjustments.**

1. With the valve assembled and actuator mounted, make sure the valve plug is in the closed position. Then turn the two stem locknuts (key 23) all the way onto the stem thread.
2. Starting with the cylinder fully retracted, manually or with air pressure extend the piston rod extension the specified valve travel.
3. Attach the stem connector (key 22), clamping the piston rod extension to the valve stem. Be sure you also attach the feedback arm and travel indicator (key 3).
4. Cycle the actuator to check availability of desired total travel and that the valve plug seats before the cylinder reaches the end of its stroke. You can make minor travel adjustments, if necessary, by loosening the stem connector (key 22) slightly, tightening the locknuts (key 23) together, and (with the valve plug off the seat) screwing the stem either into or out of the stem connector (key 22) by means of a wrench on the locknuts.
5. If the total travel is adequate, tighten the stem connector (key 22) securely, lock the stem locknuts (key 23) against the connector, and adjust the indicator scale (key 7) on the yoke to show valve plug position.
6. Provide a gauge, if necessary, to measure the pressure to the actuator. Make a final adjustment on the positioner to set the starting point of valve travel and to obtain full travel for the given instrument range.

# 585C Actuator

## Parts Ordering

When corresponding with your Emerson Process Management sales office about this equipment, refer to the serial number found on the actuator nameplate (key 21). Also, specify the complete 11-character part number from the following Parts List when ordering replacement parts.

**circumstances, be used in any Fisher valve, because they will void your warranty, might adversely affect the performance of the valve, and could give rise to personal injury and property damage.**

**Note**

**Neither Emerson, Emerson Process Management, nor any of their affiliated entities assumes responsibility for the selection, use and maintenance of any product. Responsibility for the selection, use, and maintenance of any product remains with the purchaser and end-user.**



**WARNING**

**Use only genuine Fisher® replacement parts. Components that are not supplied by Emerson Process Management should not, under any**

## Parts Kits

Actuator Size	Parts Kit Description	Parts Kit Number
25	O-ring (contains keys 7, 8, and 9)	R585CX00252
50	Backup ring (key 25) for size 50 actuators only	R585CX00502
60 (2-inch maximum travel)	O-ring (contains keys 7, 8, 9, and 27) Piston rod boot (key 29) and Snap ring (keys 30 and 31)	R585CX00012
60 (4-inch maximum travel)	O-ring (contains keys 7, 8, 9, and 27) Piston rod boot (key 29) and Snap ring (keys 30 and 31)	R585CX00022
60 (2-, 4-, and 8-inch maximum travel w/ handwheel) (8-inch maximum travel)	O-ring (contains keys 7, 8, 9, and 27)	R585CX00032
68 (2-, 4-, and 8-inch maximum travel w/ handwheel)	O-ring (contains keys 7, 8, 9, 27, and 112)	R585CX00102
68 (2-, 4-, and 8-inch maximum travel) 80 (8-inch maximum travel) 80 (2-, 4-, and 8-inch maximum travel w/ handwheel)	O-ring (contains keys 7, 8, 9, and 27)	R585CX00042
80 (4-inch maximum travel)	O-ring (contains keys 7, 8, 9, and 27) Piston rod boot (key 29) and Snap ring (keys 30 and 31)	R585CX00052
100 (4-inch maximum travel)	O-ring (contains keys 7, 8, 9, and 27) Piston rod boot (key 29) and Snap ring (keys 30 and 31)	R585CX00062
100 (8-inch maximum travel) 4- and 8-inch maximum travel w/ handwheel)	O-ring (contains keys 7, 8, 9, and 27)	R585CX00072
130 (4-inch travel)	O-ring (contains keys 7, 8, 9, and 27) Piston rod boot (key 29) and Snap ring (keys 30 and 31)	R585CX00082
130 (8-inch travel) (4- and 8-inch travel with handwheel)	O-ring (contains keys 7, 8, 9, and 27)	R585CX00092

**Parts List**

**Note**

Part numbers are shown for recommended spares only. For part numbers not shown, contact your Emerson Process Management sales office.

Key	Description	Part Number
23	Hex Nut (2 req'd)	
24	Lithium grease (not furnished with actuator)	
25*	Back-Up Ring, Size 50 only (use with Nitrile or FKM O-rings) Nitrile	14B8259X012
71	Warning Nameplate	
75	Spacer (2 req'd)	

**Sizes 25 & 50**

**Common Actuator Parts (figure 5 or 7)**

Key	Description	Part Number
1	Cylinder	
2	Cylinder-to-Yoke Bolts	
3	Piston, aluminum	
4	Cap Screw, for actuators without handwheel	
5	Travel Stop Spacer, zn-pl steel	
6	Yoke, ductile iron	
7*	Yoke O-ring For size 25 Nitrile	13A5599X062
	FKM (fluorocarbon) (for high temperature) For size 50 Nitrile	13A5599X022
	FKM (for high temperature)	1L315906992
	FKM (for high temperature)	1L3159X0012
8*	Piston O-ring For size 25 Nitrile	19A7098X022
	FKM (for high temperature)	19A7098X032
	For size 50 Nitrile	1F1727X0032
	FKM (for high temperature)	1F1727X0012
9*	Actuator Stem O-ring For size 25 Nitrile	1H8498X0022
	FKM (for high temperature)	1H8498X0032
	For size 50 Nitrile	1E736906992
	FKM (for high temperature)	1D2620X0032
10	Actuator Stem, chrome plated steel	
11*	Piston Stem Bearing, nylon For size 25	18A0616X012
	For size 50	24B6313X012
12	Stem Connector, zn pl steel	
13	Stem Connector Nut	
14	Cap Screw (2 req'd)	
15	Hex Nut	
16	Bias Spring, outer (steel) (see table 8-11 for use)	
17	Bias Spring, inner (steel) (see table 8-11 for use)	
18	Self Tapping Screw (2 req'd)	
19	Travel Indicator Scale	
20	Drive Screw, stainless steel (7 req'd)	
21	Nameplate	
22	Warning Tag, stainless steel	

**Additional Parts for Actuator with Handwheel (figure 6 or 8)**

1	Cylinder,	
35	Neutral Indicator Cover, polycarbonate	
36	Handwheel Housing, cast iron	
37	Neutral Indicator Plate, polycarbonate	
38	Bearing Cover, cast iron	
39	Thrust Bearing, chrome steel	
40	Anti-rotation Key, Zn pl steel	
42	Neutral Indicator, stainless steel	
43	Neutral Indicator Plate Screw, pl steel (2 req'd)	
45	Handwheel Stem Washer, heat treated	
46	Operating Nut	
47	Handwheel, cast iron	
48	Handwheel Retaining Ring, pl steel	
50	Grease Fitting, Cd pl steel	
51	Bearing Cover Set Screw, pl steel (3 req'd)	
52	Handwheel Jam Nut, steel	
53	Button Plug, plastic	
56	Handwheel Stem, heat treated ENC 416 stainless steel	
57*	Cylinder Cover O-Ring, nitrile For Push Only Size 25	1D237506992
	Size 50	1D885506992
	Other, Size 25 and 50	1C4157X0022
58*	Handwheel Housing O-Ring, nitrile For Push Only Size 25	1D348306992
	Size 50	1C628006992
	Other, Size 25 and 50	1H624506992
60	Handwheel Stem Cap Screw, Zn pl steel (4 req'd for size 25), (3 req'd for size 50)	
63	Detent Spring	
64	Detent Ball, Cr pl steel	
65	Locking Key, steel	
66	Bypass Valve	
67	Bypass Tubing	
68	Bypass Tee	
69	Piston Stud	
70	Thread locking adhesive (medium strength) (not furnished with actuator)	
72	Hex Nut, Slotted	
73	Cotter Pin	
74	Elbow, Tube	

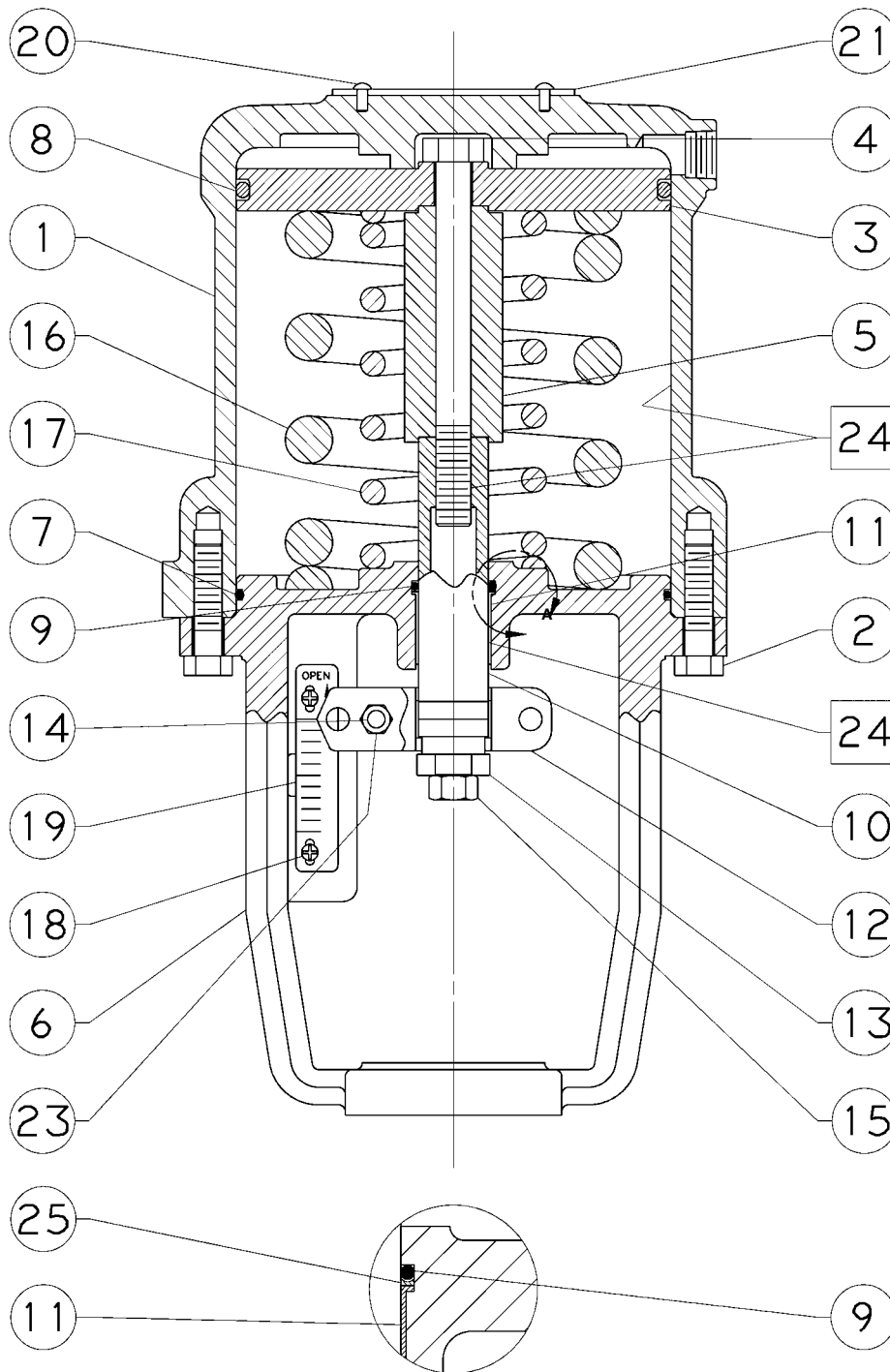

VIEW A  
SIZE 50

□ APPLY LUB  
NOTE:  
KEY NUMBERS 22 AND 71 NOT SHOWN  
44B6335-C / DOC

Figure 5. Type 585C Size 25 and 50 Actuators  
(spring retracts actuator rod)

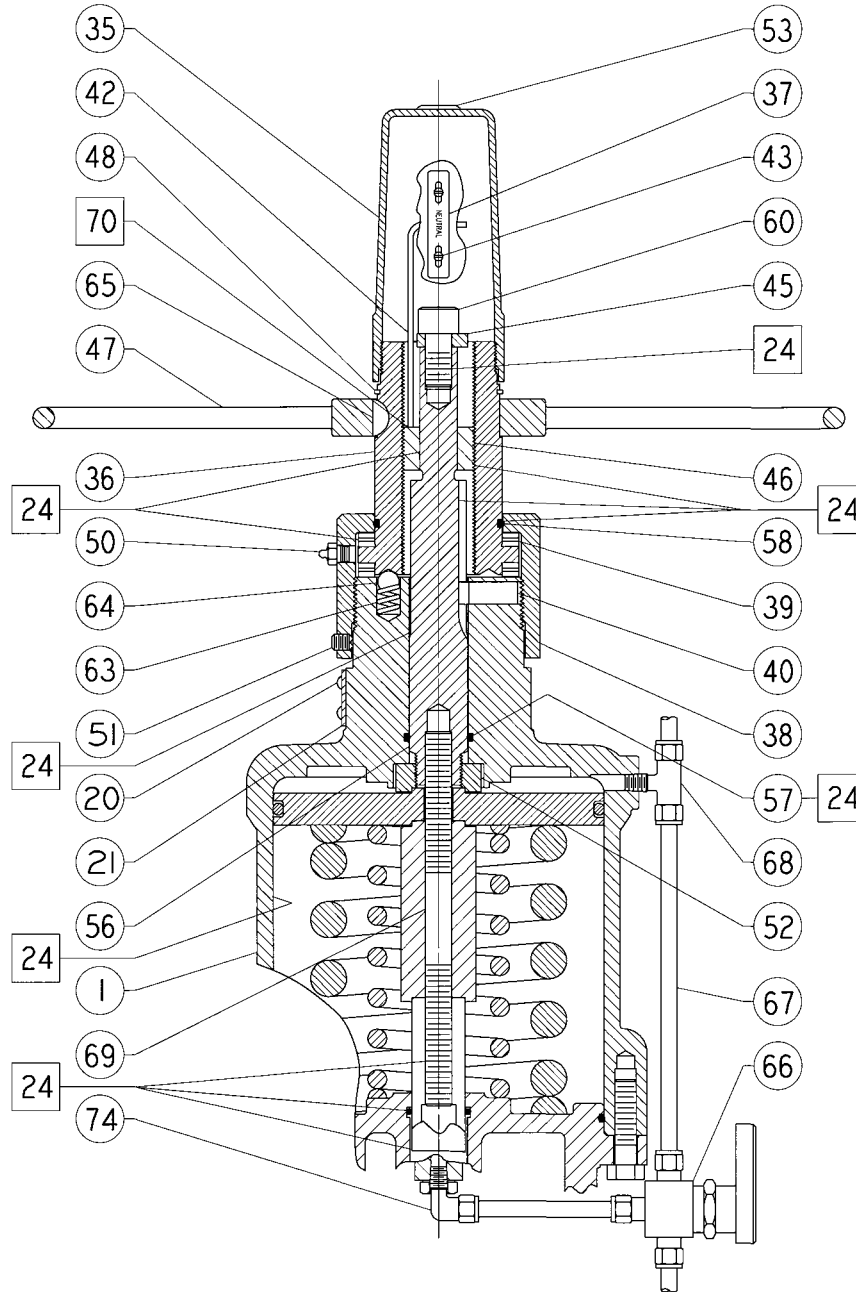

**HANDWHEEL ASSEMBLY**

□ APPLY LUB  
44B6330-B

*Figure 6. Type 585C Size 25 and 50 Actuators Handwheel Assembly  
(spring retracts actuator rod)*

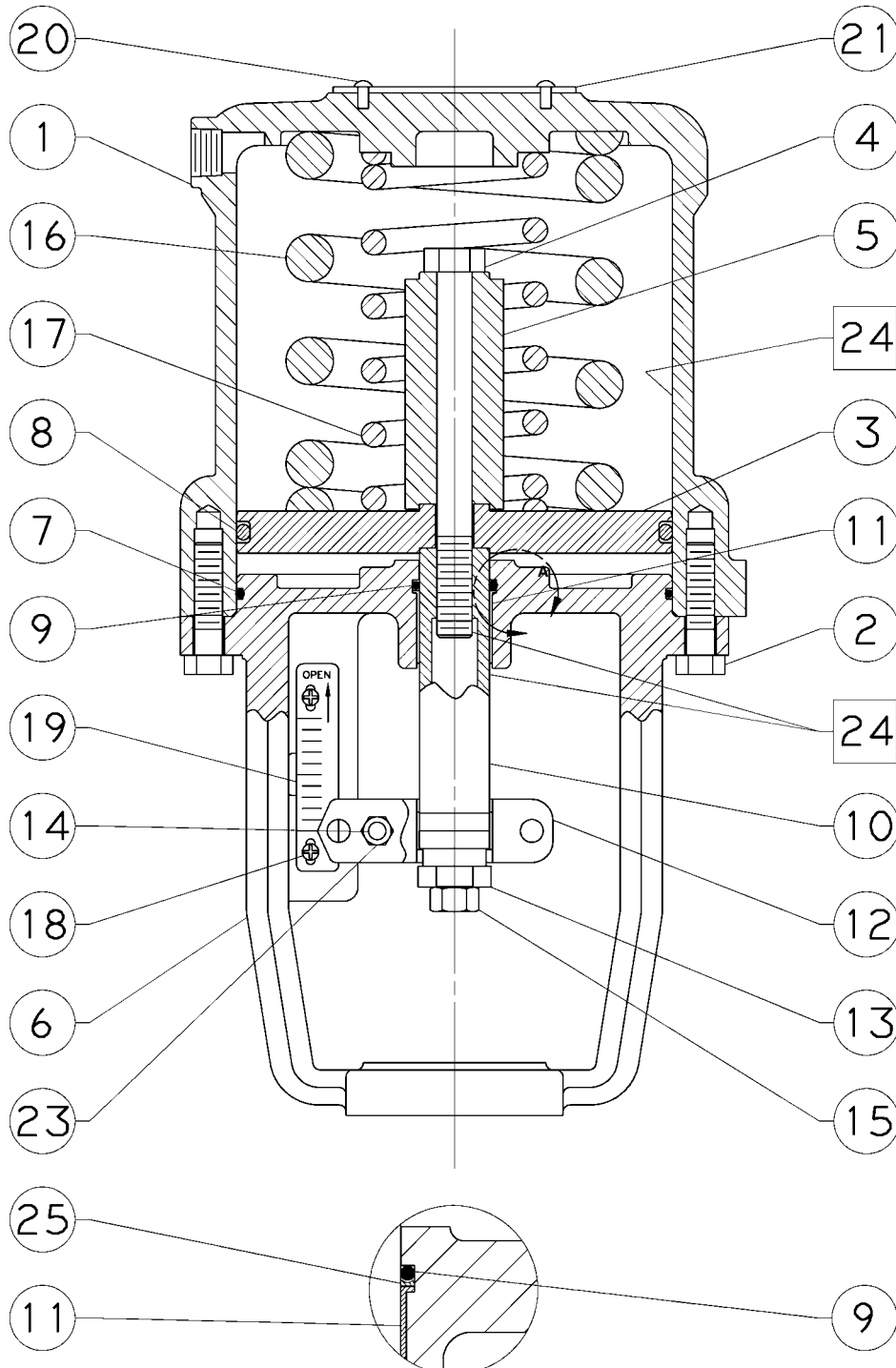

□ APPLY LUB  
NOTE:  
KEY NUMBERS 22 AND 71 NOT SHOWN  
4486319-C

VIEW A  
SIZE 50

Figure 7. Type 585C Size 25 and 50 Actuators  
(spring extends actuator rod)

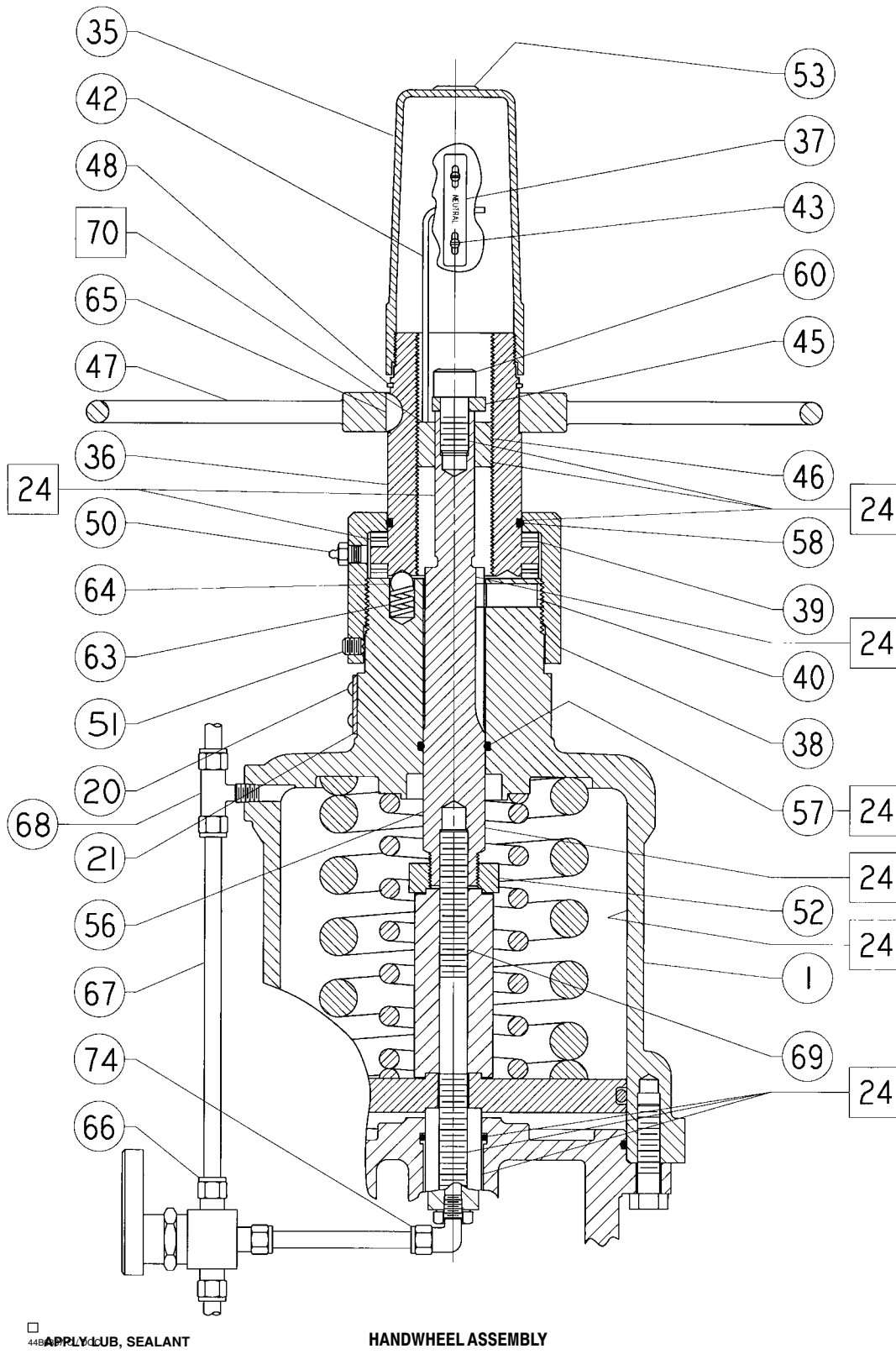
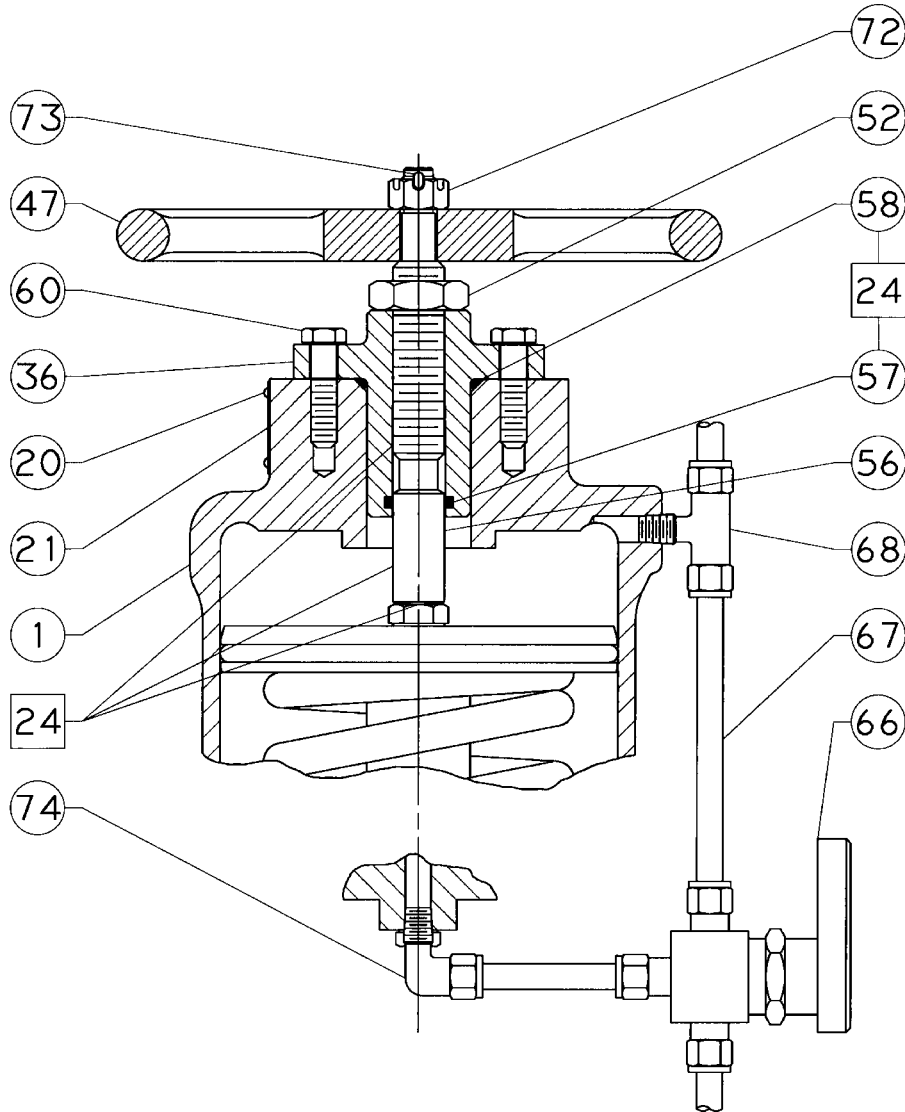

Figure 8. Type 585C Size 25 and 50 Actuators Handwheel Assembly  
(spring extends actuator rod)



□ APPLY LUB  
34B8587-B

**HANDWHEEL ASSEMBLY**

*Figure 9. Type 585C Size 25 and 50 Actuators Handwheel Assembly—Direct Acting, Push Only  
(spring retracts actuator rod)*

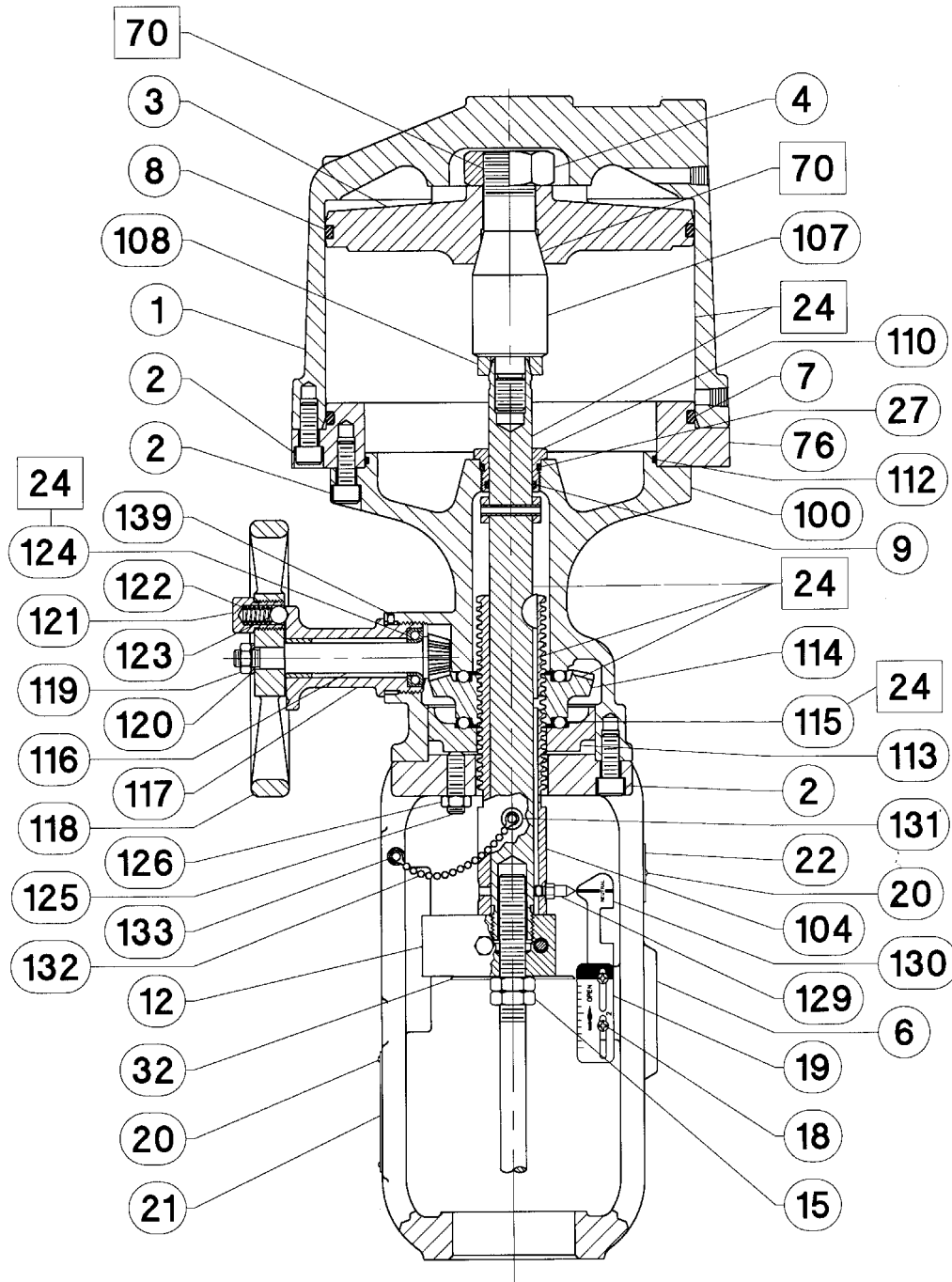

□ APPLY LUB/SEALANT  
PARTS NOT SHOWN: 33, 145, 146  
FOR BYPASS ASSEMBLY, SEE FIGURE 14  
58B1370-A

Figure 10. Type 585C Actuator with Integral Handjack  
Size 68 with 2- and 4-Inch Travel

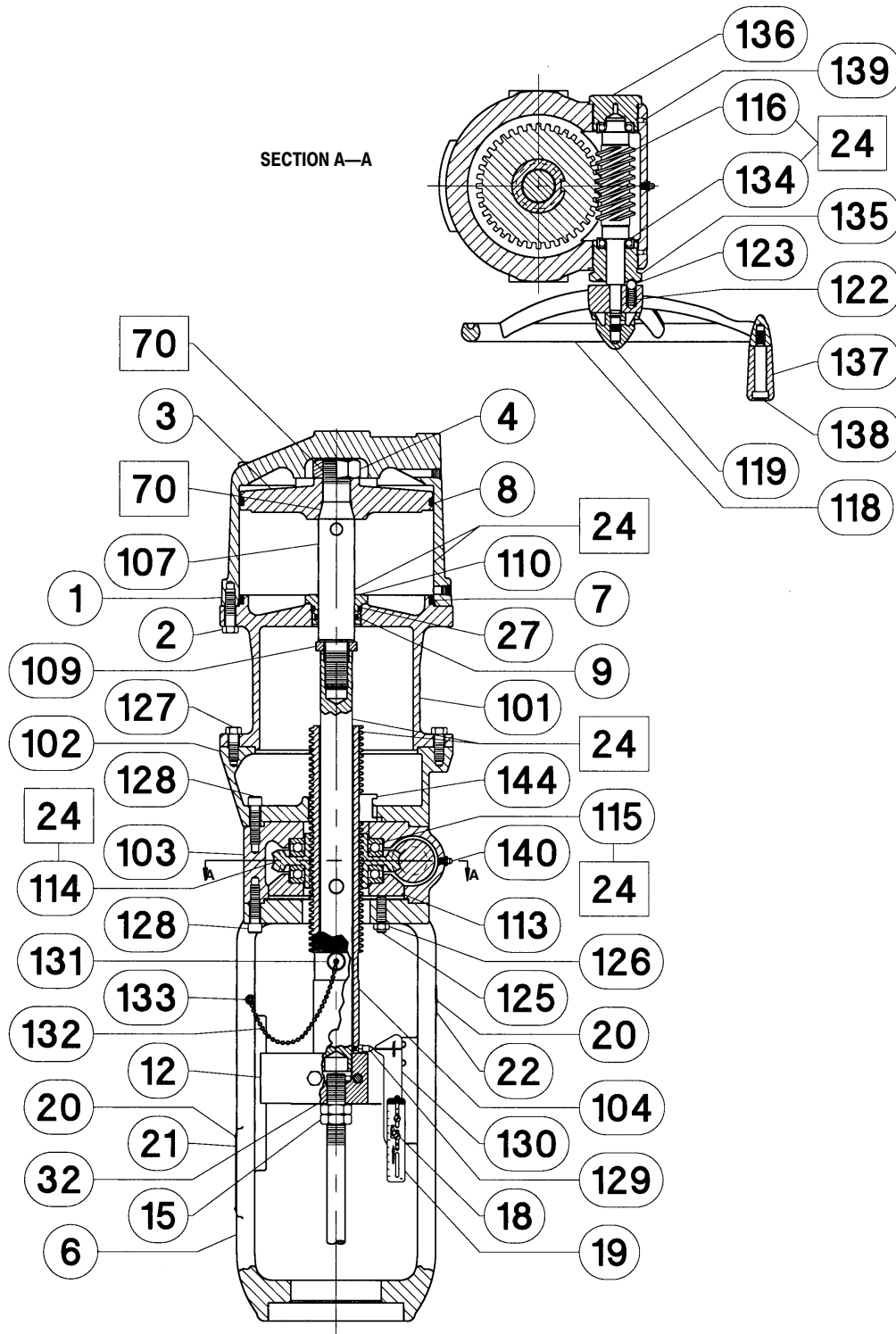

□ APPLY LUB/SEALANT

PARTS NOT SHOWN: 141, 145, 146  
FOR BYPASS ASSEMBLY, SEE FIGURE 14

58B1373-A

Figure 11. Type 585C Actuator with Integral Handjack  
Size 80 and 100 with 4-Inch Travel

# Instruction Manual

Form 5353  
June 2007

# 585C Actuator

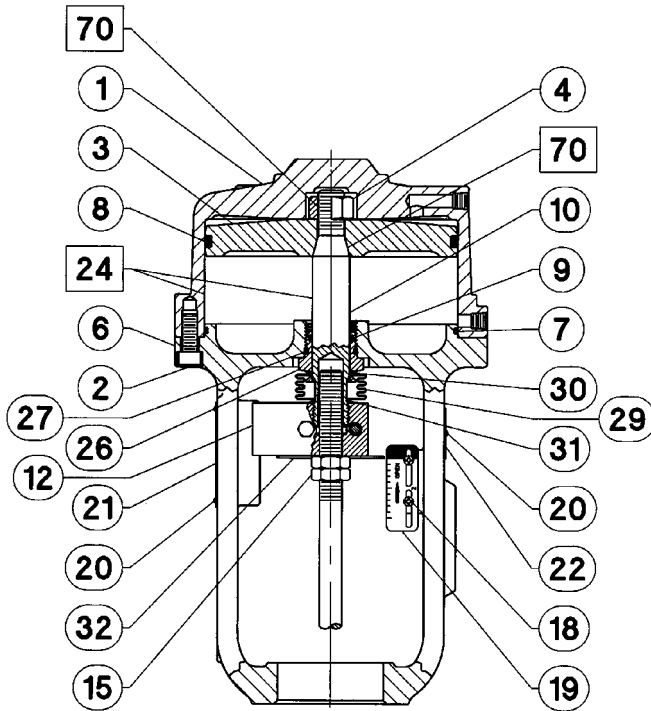

□ APPLY LUB/SEALANT  
PARTS NOT SHOWN: 33  
58B1365-A

Figure 12. Type 585C Actuator  
Size 60 with 2- and 4-Inch Travel

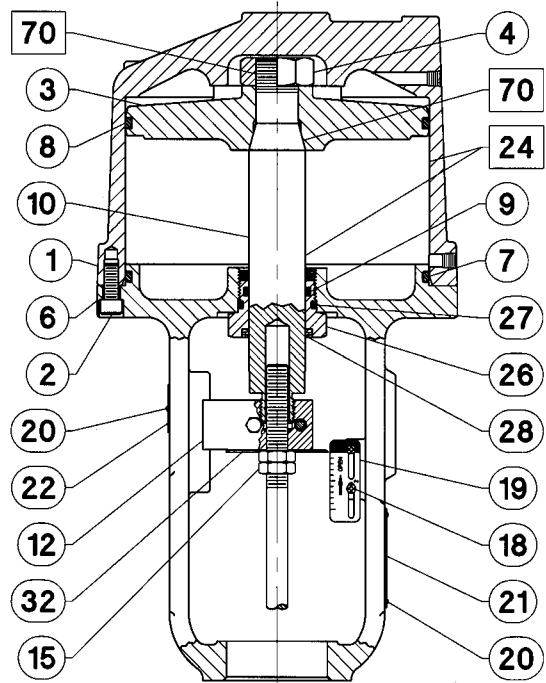

□ APPLY LUB/SEALANT  
PARTS NOT SHOWN: 33  
58B1366-A

Figure 13. Type 585C Actuator  
Size 60 with 8-Inch Travel and  
Size 68 with 2-, 4-, and 8-Inch Travel

## Sizes 60-130 (figures 10-14)

Key	Description	Part Number
1	Cylinder Assembly, aluminum	
2	Cap Screw, pl alloy steel (not shown)	
3	Piston, aluminum	
4	Piston Nut, pl steel	
6	Yoke	
7*	O-Ring, nitrile	
	Size 60	1H862306992
	Size 68, 80	1H862506992
	Size 100	1H862606992
	Size 130	1J453806992
8*	O-Ring, nitrile	
	Size 60	1H862406992
	Size 68, 80	1H862506992
	Size 100	1H862606992
	Size 130	1J453806992
9*	O-Ring, nitrile	
	Size 60	1E736906992
	Size 68, 80, 100	1H862706992
	Size 130	1J453706992
10	Actuator Stem, S41600 (416 SST) Cr pl	
12	Stem Connector Assembly, zinc-plated steel	
15	Hex Nut, pl steel	
18	Screw (2 req'd)	

Key	Description	Part Number
19	Travel Indicator Scale, stainless steel	
20	Drive Screw, stainless steel	
21	Nameplate, stainless steel	
22	Warning Nameplate (not shown)	
24	Lithium grease (not furnished with actuator)	
26*	Lower Seal Bushing, brass	
	Size 60	
	2- and 4-inch travel	1H863714042
	8-inch travel	1R875914042
	Size 68 (2-, 4-, & 8-inch tvl), Size 80 and 100 (8-inch tvl)	1R945614042
	Size 80 and 100 (4-inch tvl)	2H873014042
	Size 130	
	4-inch travel	2K378314042
	8-inch travel	23A1073X012
27*	O-Ring, nitrile	
	Size 60	1D348306992
	Size 68, 80, 100	1C334206992
	Size 130	1D439206992
28*	Wiper Scraper, vendor	
	Size 60 (8-inch travel)	1R876099012
	Size 68 (2-, 4-, & 8-inch tvl), Size 80 and 100 (8-inch travel)	1R946499012
	Size 130 (8-inch travel)	11A4989X012

\*Recommended spare parts

Key	Description	Part Number
29*	Piston Rod Boot, neoprene	
	Size 60	
	2-inch travel	1H864706992
	4-inch travel	1H937906992
	Size 80 and 100 (4-inch travel only)	1H872106992
	Size 130 (4-inch travel only)	1J453906992
30*	Snap Ring, pl steel	
	Size 60	
	2- and 4-inch travel only	1H863827022
	Size 80 and 100 (4-inch travel only)	1H875027022
	Size 130 (4-inch travel only)	1J454127022
31*	Snap Ring, pl steel	
	Size 60	
	2- and 4-inch travel only	1H863927022
	Size 80 and 100 (4-inch travel only)	1H875127022
	Size 130 (4-inch travel only)	1P661327022
32	Travel Indicator Disk, S41300 (413 SST)	
33	Twin Speed Nut, stainless steel (not shown)	
34	Machine Screw, pl steel	
70	Thread locking adhesive (medium strength) (not furnished with actuator)	
76	Adaptor Flange, Class C cast iron	
76	Cylinder Flange, cast iron	
77	Cap Screws, pl steel	
90	Pipe Nipple, 316 SST (not shown)	
91	Pipe Tee, 316 SST	
92	Needle Valve	
100	Cylinder Flange, cast iron	
101	Cylinder Adaptor, A07130 aluminum	
102	Spacer, cast iron	
103	Gear Case, cast iron	
104	Sleeve Assembly, S41600 (416 stainless steel)	
105	Sleeve, S41600 (416 stainless steel)	
106	Actuator Stem, S41600 (416 stainless steel)	
107	Piston Connector, S41600 (416 stainless steel)	
108	Piston Ring Adaptor, S41600 (416 stainless steel)	
109	Washer, steel	
110*	Upper Seal Bushing, brass	
	Size 60 and 68	1H865114042
	Size 80 and 100	1H946314042
	Size 130	23A1073X012
111	Retaining Ring, stainless steel	
112*	O-Ring, nitrile, Size 68	1H862306992
113	Bearing Retainer, Class 30 cast iron	
114	Bevel Gear, cast iron	
114	Worm Gear, bronze	
115	Thrust Bearing, carbon steel (2 req'd)	
116	Bevel Pinion, S41600 (416 stainless steel)	
116	Worm Shaft, steel	
117	Extension, carbon steel	
118	Handwheel, cast iron	
119	Handwheel Cap, cast iron	
119	Hex Nut, steel (1 req'd)	
120	Lockwasher, carbon steel	
121	Spring Cap, G12144 carbon steel	
122	Spring, phos. bronze	
123	Ball, steel	
123	Cover Screw, steel	
124	Combination Bearing, vendor	
125	Set Screw, alloy steel	
126	Hex Nut, steel	
127	Cap Screw, steel	
128	Cap Screw, steel	

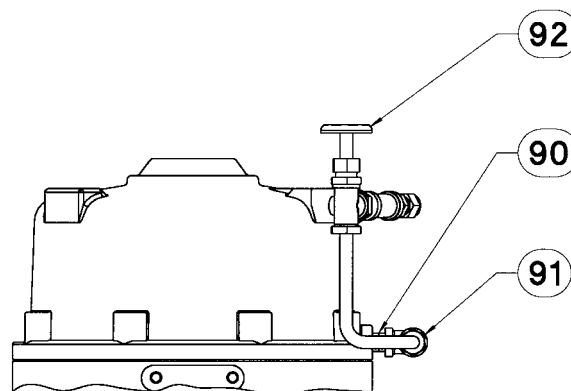

39B1397/A

Figure 14. Type 585C Size 60-130 Bypass Assembly

Key	Description	Part Number
129	Pointer, S41600 (416 stainless steel)	
130	Handjack Indicator, stainless steel	
131	Locking Pin, S41600 (416 stainless steel)	
132	Chain, stainless steel	
133	Drive Screw, carbon steel	
134	Ball Bearing, steel	
135	Front Worm Retainer, steel	
136	Back Worm Retainer, steel	
137	Hand Grip, G12144 carbon steel	
138	Hand Grip Bolt, steel	
139	Set Screw, steel	
140	Zerk Fitting, steel	
141	Ring, carbon steel	
142	Machine Screw, carbon steel (2 req'd)	
143	Key, S41600 (416 stainless steel)	
144	Key, G10180 carbon steel	
145	Caution Tag (not shown)	
146	Cable Tie (2 Req'd) (not shown)	

## Long-Stroke Parts List (figures 15 and 16)

In the listing below, some parts are related to a 6-inch wide channel yoke leg or an 8-inch wide channel yoke leg. This refers to the size of the vertical channel iron member of the yoke. This is not to be confused with a 5H or 7-inch diameter yoke boss, which refers to the actuator-to-valve mounting design.

Some parts are also related to the piston rod or piston rod extension diameter. This measurement should be taken above the stem connector where the rod is full diameter.

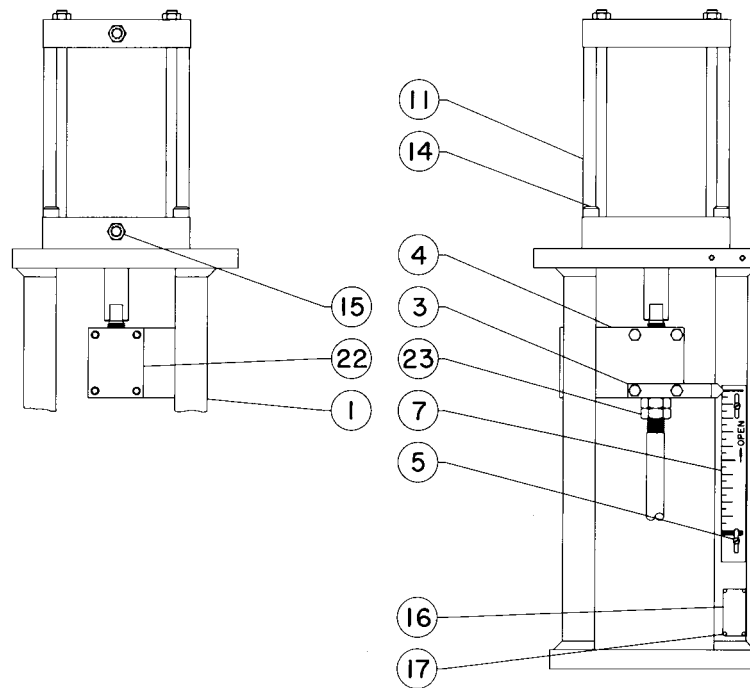

52A7783-A

Figure 15. Type 585C Long-Stroke Actuator

Key	Description	Part Number	Key	Description	Part Number
1	Yoke		24	Handwheel Indicator, SST	
2	Cable Protector, galvanized steel		25	Chain, SST	
3	Travel Indicator, SST		26	Drive Screw, plated steel	
4	Feedback Arm, pl steel		27	Set Screw, steel	
4	Anti-Rotator, steel		28	Key, steel	
5	Machine Screw, steel pl		29	Front Worm Retainer, steel	
6	Washer, steel pl		30	Back Worm Retainer, steel	
7	Travel Scale, aluminum		31	Worm Shaft, steel	
8	Handwheel Extension		32	Handwheel, cast iron	
9	Sleeve Assembly		33	Handgrip, steel	
10	Locking Pin, 416 SST		34	Handgrip bolt, steel	
11	Air Cylinder		35	Handwheel Cap, cast iron	
	Refer to the nameplate attached to the cylinder. Order all replacement parts for the cylinder from the cylinder manufacturer. Also, if the handwheel is specified, order its replacement parts from the cylinder manufacturer. When corresponding with the cylinder manufacturer, include the cylinder serial number, model number, and all other pertinent nameplate information.		36	Set Screw, steel	
12	Pipe Plug, steel		37	Zerk Fitting	
13	Cap Screw, plated steel		38	Ball, alloy steel	
14	Cap Screw, plated steel		39	Spring, phosphor bronze	
15	Bushing		40	Ball Bearing	
16	Nameplate, SST		41	Hex Nut, plated steel	
17	Drive Screw, SST		42	Pointer, SST	
18	Gear Case, cast iron		43	Conduit Clamp	
19	Worm Gear, bronze		44	Cap Screw, plated steel	
20	Bearing		45	Machine Screw, plated steel	
21	Bearing Retainer, steel		46	Machine Screw, plated steel	
22	Stem Connector, 410 SST		47	Tubing, copper (specify length)	
23	Hex Nut, plated steel		49	Connector, brass	
			50	Elbow, brass	
			51	Positioner	
			52	Machine Screw, SST	
			53	Lock Washer, SST	
			54	Needle Valve	
			55	Pipe Nipple, steel	
			56	Pipe Tee, steel	

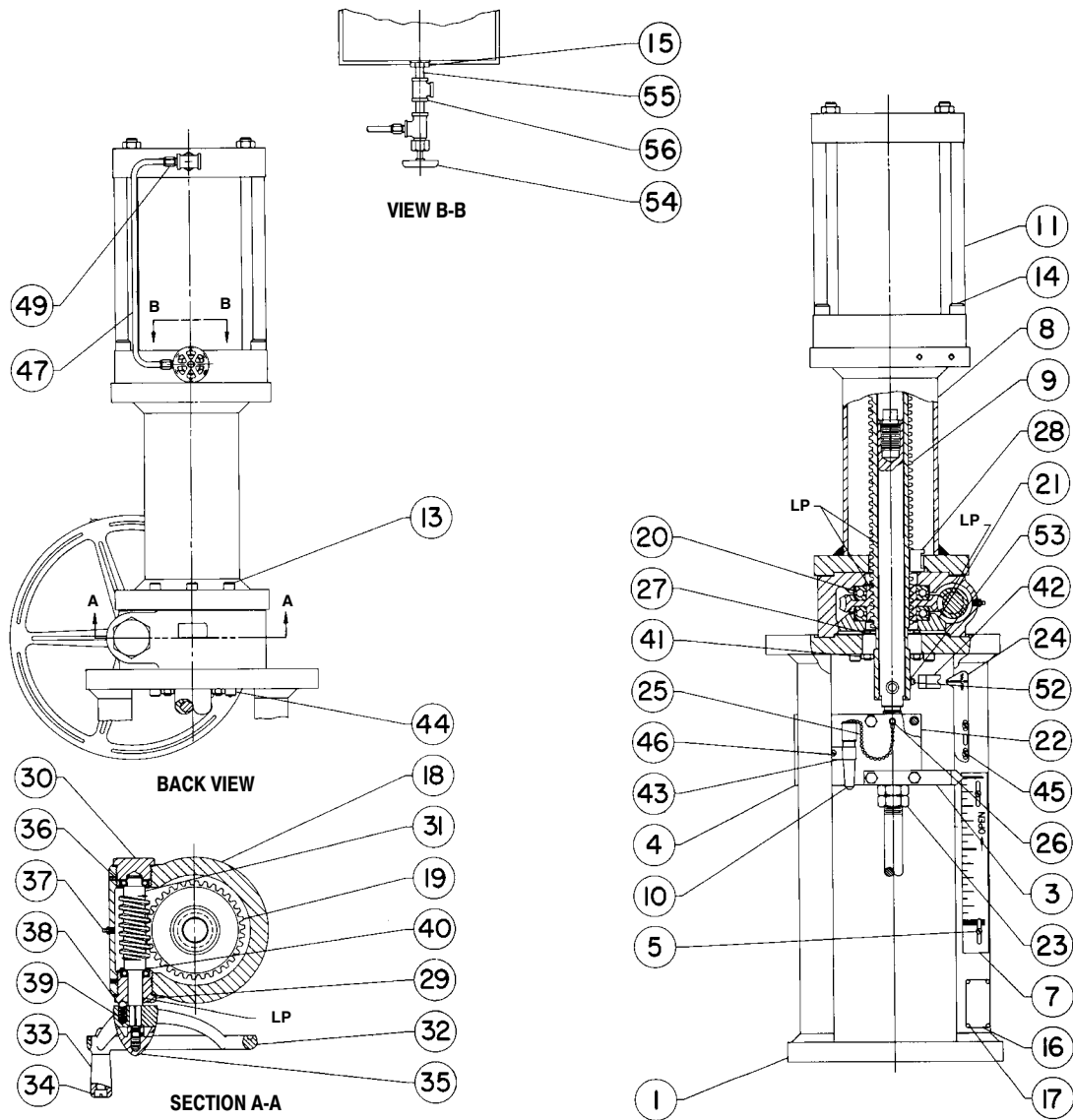

LP-LUBRIPLATE NO. 130AA  
 PACK PARTS 20 AND 40 WITH MULTIPURPOSE GREASE  
 52A7782-A

Figure 16. Type 585C Long-Stroke Actuator

FIELDVUE and Fisher are marks owned by Fisher Controls International LLC, a member of the Emerson LP Management business division of Emerson Electric Co. Emerson Process Management, Emerson, and the Emerson logo are trademarks and service marks of Emerson Electric Co. All other marks are the property of their respective owners.

The contents of this publication are presented for informational purposes only, and while every effort has been made to ensure their accuracy, they are not to be construed as warranties or guarantees, express or implied, regarding the products or services described herein or their use or applicability. We reserve the right to modify or improve the designs or specifications of such products at any time without notice.

Neither Emerson, Emerson Process Management, nor any of their affiliated entities assumes responsibility for the selection, use and maintenance of any product. Responsibility for the selection, use and maintenance of any product remains with the purchaser and end-user.

**Emerson Process Management**

Marshalltown, Iowa 50158 USA  
 Cernay 68700 France  
 Sao Paulo 05424 Brazil  
 Singapore 128461

www.Fisher.com

