

377 Series Trip Valves

The 377 Series pressure-sensing trip valves (see figures 1 and 2) are for control applications where a specific valve/actuator action is required when supply pressure falls below a specific point. When supply pressure falls below the trip point (see figure 3), the trip valve causes the actuator to fail up, lock in the last position, or fail down. When the supply pressure rises above the trip point, the 377 Series trip valve automatically resets, allowing the system to return to normal operation. The trip valve can be top-mounted on a manifold, yoke-mounted, or bracket-mounted to match the application requirements. The 377 Series trip valves can be used with 480, 585C, 1061, 1066, 1069, and G Series piston actuators.



W4292-1/IL

Figure 1. 377 Series Trip Valve

Features

- **Cost Effective**—Single trip valve construction reduces costs and spare part requirements of those systems using three separate switching valves to perform the failure functions. A single trip valve greatly simplifies piping requirements.
- **Ease of Mode Conversion**—Conversion to any of the fail modes requires only minor hookup changes.
- **Adjustable Trip Valve**—The trip point is adjustable for specific supply pressure requirements.
- **Reliable Operation**—The trip valve design includes large diaphragm areas and few moving parts for efficient performance, minimum maintenance, and long service life.

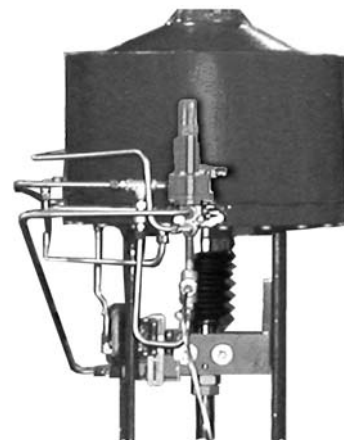

W8435-1

Figure 2. Type 377 Trip Valve Mounted on Size 130 Type 585C Actuator



Specifications

Available Configurations

When supply pressure falls below the trip point,

Type 377D Trip Valve: Fails actuator piston down. Includes check valve and volume tank

Type 377L Trip Valve: Locks actuator piston in the last position

Type 377U Trip Valve: Fails actuator piston up. Includes check valve and volume tank.

Type 377CW Trip Valve: Fails fully clockwise to close the valve. Requires check valve and volume tank. Trip valve moves piston to either up/down position and requires actuator configuration for actual clockwise movement.

Type 377CCW Trip Valve: Fails fully counterclockwise to close the valve. Requires check valve and volume tank. Trip valve moves piston to either up/down position and requires actuator configuration for actual counterclockwise movement.

All 377 Series Trip Valves can be converted to any of the above fail modes with minor hookup changes

Allowable Supply Pressure for Trip Valve⁽¹⁾

Maximum: 10.3 bar (150 psig)

Minimum: 3.8 bar (55 psig)

Outlet Pressure⁽¹⁾

Normal Operation: Pressure from control device

Fail-Up or Fail-Down Mode: Maximum volume tank pressure

Lock-In-Last-Position: Respective cylinder pressure

Trip Point⁽²⁾

Adjustable from a minimum of 2.8 bar (40 psig) to a maximum of 72 percent of supply pressure; see figure 3.

Reset: 12.5 to 33 percent above adjusted trip point

Flow Coefficients (C_v)⁽³⁾

Depends on flow path (shown in figure 4) as follows:

Port A to Port B: 0.47

Port B to Port C: 0.56

Port D to Port E: 0.48

Port E to Port F: 0.64

Body Connections

1/4-inch NPT female

Temperature Capabilities⁽¹⁾

Nitrile Diaphragms and O-Rings: -40 to 82°C (-40 to 180°F)

Fluoroelastomer Diaphragms and O-Rings: -18 to 104°C (0 to 220°F)

Volume Tank Maximum Internal Working Pressure (for Type 377D, 377U, 377CW and 377CCW trip valves)

Standard: 10.3 bar (150 psig) for non-ASME approved applications⁽⁴⁾

ASME Approved Applications: Rated 10.3 bar (150 psig), maximum; 9.3 bar (135 psig), recommended

Volume Tank Sizing

See sizing section

Hazardous Area Classification

Complies with the requirements of ATEX Group II Category 2 Gas and Dust

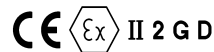

Mounting

Top-Mounted: Manifold-mounted between a 3570 Series positioner and 480 Series actuator (manifolds cannot be supplied with 585C, 1061, 1066, and 1069 Series piston actuators)

Side-Mounted: Yoke-mounted or bracket-mounted for use with a FIELDVUE[®] DVC6000 or DVC6000f Series digital valve controller

Continued

Specifications (continued)

Approximate Weight

Trip Valve: 2.0 kg (4.5 pounds)
Mounting Manifold: 0.5 kg (1.2 pounds)
Volume Tank: Varies between 5.4 and 21 kg (12 and 47 pounds) depending on size

Construction Materials

Body, Spring Case, and Manifold—Aluminum
Cover—25% mineral-filled thermoplastic polyester
O-Rings—nitrile or fluoroelastomer
Diaphragms—nitrile or fluoroelastomer
Interior parts—brass, aluminum, steel, and stainless steel

1. The pressure/temperature limits in this document and any applicable standard or code limitation should not be exceeded.
 2. If the trip point is not specified, the trip point is factory-set at 72 percent of supply pressure or 2.8 bar (40 psig), whichever is higher.
 3. Values represent nominal C_v measures for each port pair using a trip valve/actuator combination.
 4. This tank is rated at 14.5 bar (240 psig) in LP service. When used with air, the rating should be considered to be 10.3 bar (150 psig), consistent with the maximum pressure allowed for the 377 Series trip valve.

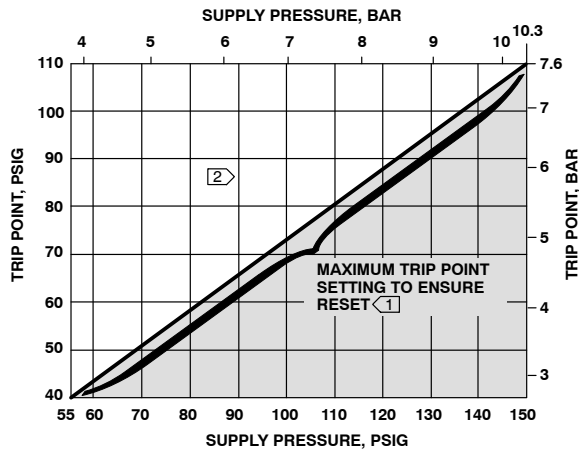

NOTE:
 1 TRIP POINT MAY BE SET TO ANY VALUE BETWEEN 2.8 BAR (40 PSIG) AND THE MAXIMUM TRIP POINT LINE.
 2 RESET OCCURS AT 12.5 TO 33 PERCENT ABOVE ADJUSTED TRIP POINT.

A2779-2/IL

Figure 3. Maximum Trip Point Settings

Note

Neither Emerson®, Emerson Process Management™, Fisher®, nor any of their affiliated entities assumes responsibility for the selection, use, and maintenance of any product. Responsibility for the selection, use, and maintenance of any product remains with the purchaser and end-user.

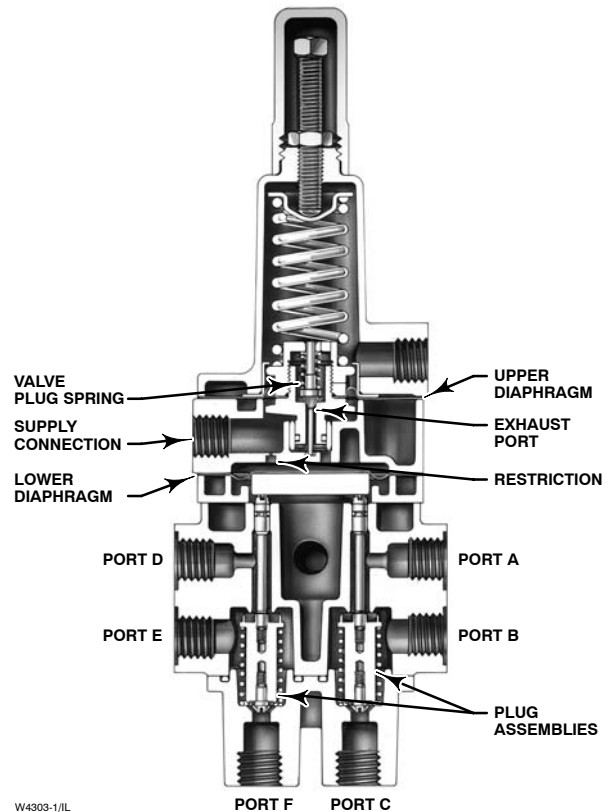

W4303-1/IL

Figure 4. Simplified Sectional View of Trip Valve

Principle of Operation

Type 377D Trip Valve

In normal operation, supply pressure loads the upper diaphragm (see figure 4) of the unit. The valve plug spring keeps the exhaust port closed. Supply pressure also loads the lower diaphragm through the

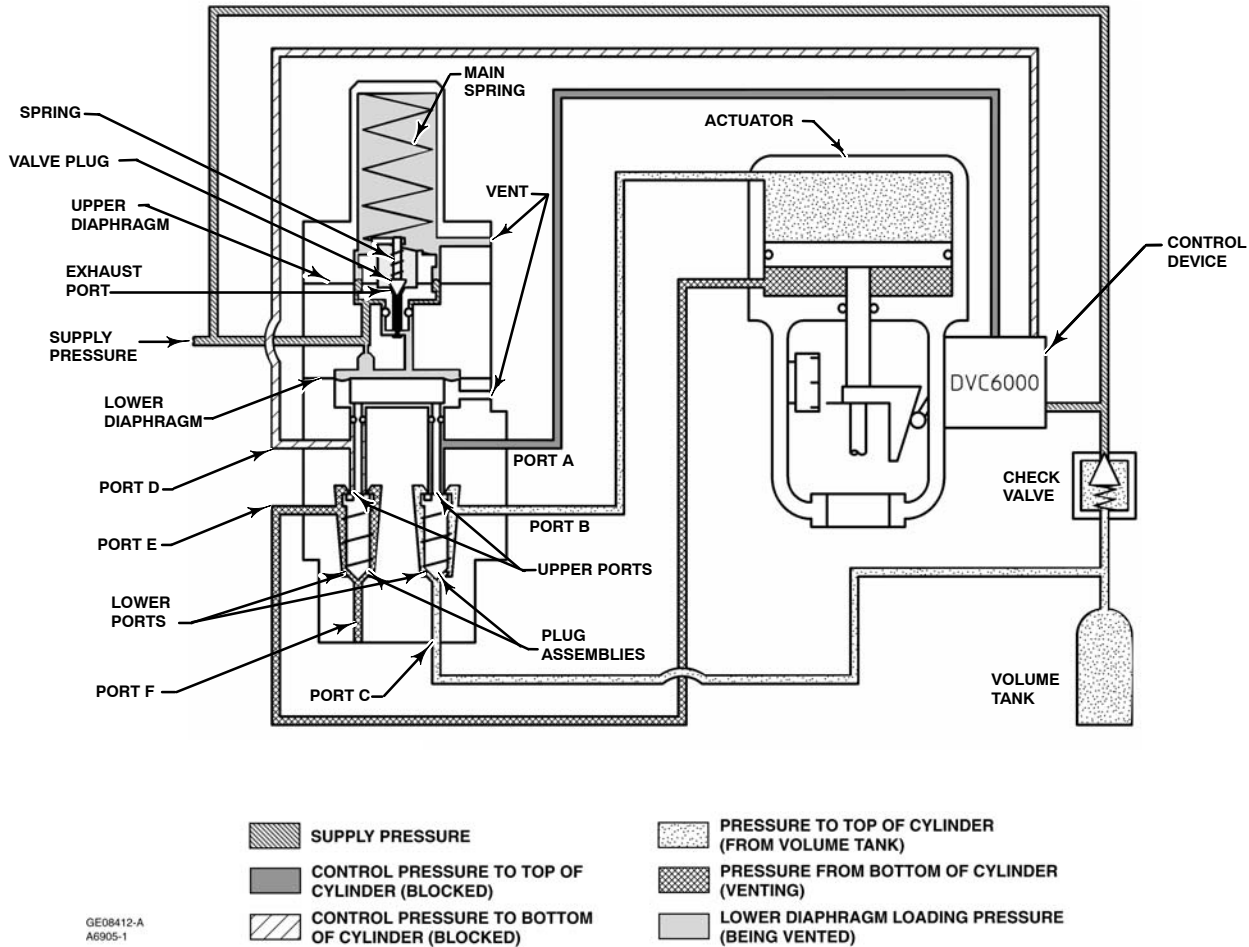

Figure 5. Type 377D Trip Valve Shown Tripped

restriction, causing the plug assemblies to move down and isolate ports C and F while connecting port A to B and port D to E. Normal actuator control pressure flows from the control device to the top of the cylinder through ports A and B and to the bottom of the cylinder through ports D and E. A volume tank is charged to maximum supply pressure through a check valve in order to retain maximum supply pressure in the volume tank if supply pressure drops.

When supply pressure falls below the trip point pressure in the fail-down mode (see figure 5), the exhaust port opens, venting the supply pressure that is loading the lower diaphragm. This causes the upper ports of the plug assemblies to close and shut off normal pressure flow from the control device to the actuator.

Volume tank pressure then flows through ports C and B to the top of the actuator cylinder, while pressure in the bottom of the actuator cylinder is vented through ports E and F. The pressure imbalance created forces the actuator piston down.

When supply pressure is restored, it loads the upper and lower diaphragms, causing the trip valve to reset. The exhaust port closes. The upper ports of the plug assemblies open, and the lower ports close. Normal actuator control pressure flow from the control device is restored through ports A and B and ports D and E. The check valve opens and recharges the volume tank to the maximum supply pressure.

Type 377L Trip Valve

When supply pressure falls below the trip point in the lock-in-last-position mode (see figure 6), the

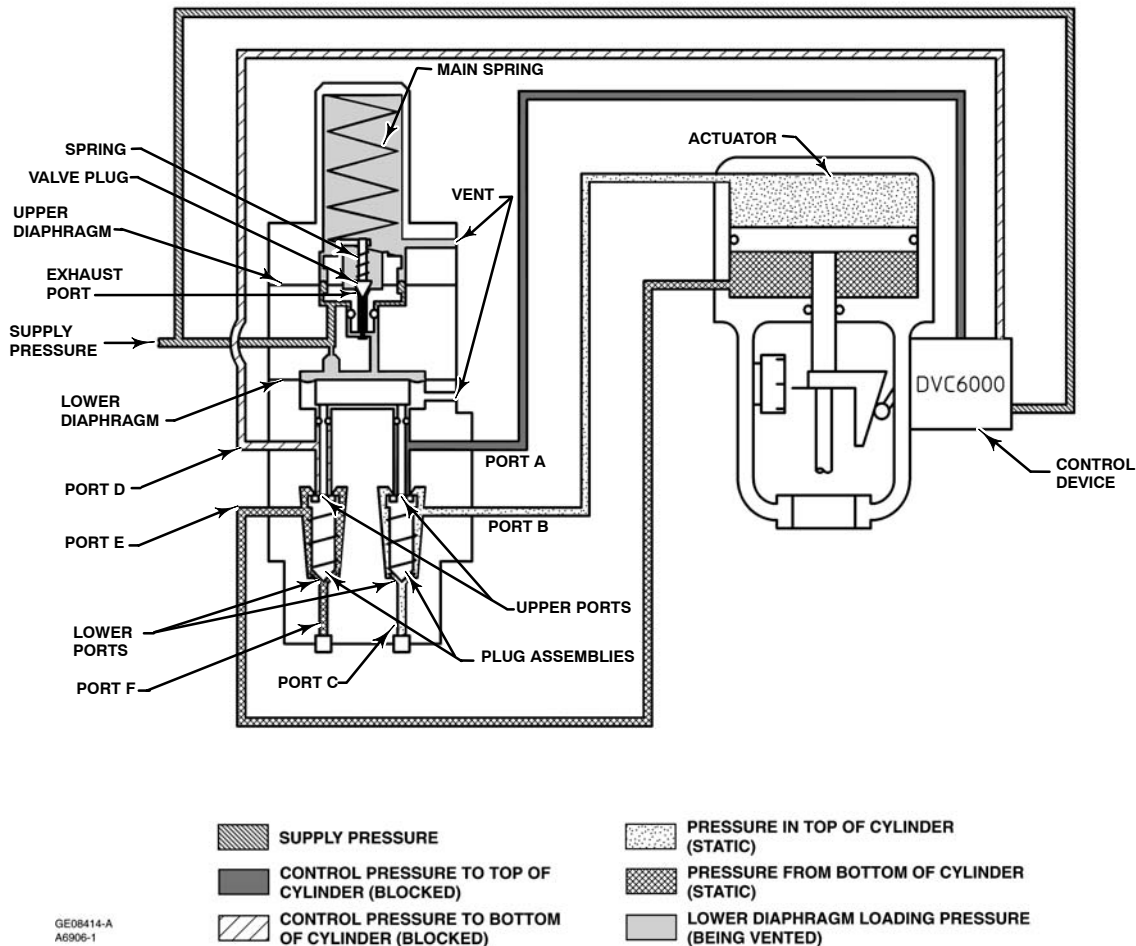

Figure 6. Type 377L Trip Valve Shown Tripped

exhaust port opens, venting supply pressure from the lower diaphragm. This causes the upper ports of the plug assemblies to close and the lower ports to open. Since ports C and F are plugged, no pressure change occurs on either side of the actuator piston, and the piston is pressure-locked in position upon loss of supply pressure. No volume tank is necessary in this mode. When supply pressure is restored, the plug assemblies move back into the normal operating position, and supply pressure flows from the control device through ports A and B to the actuator.

Type 377U Trip Valve

The fail-up mode of operation (figure 7) is similar to the fail-down mode of operation except that connections to port C and F are reversed. When

supply pressure falls below the trip point, the top of the actuator cylinder vents, and volume tank pressure loads the bottom of the actuator cylinder. The pressure imbalance created forces the actuator piston up.

Type 377CW and 377 CCW Trip Valves

Makes use of the 377D or 377U trip valve configurations, a piston actuator, and volume tank with check valve to move the piston actuator to either the up or down position. Requires the actuator and valve configuration for actual clockwise or counterclockwise movement.

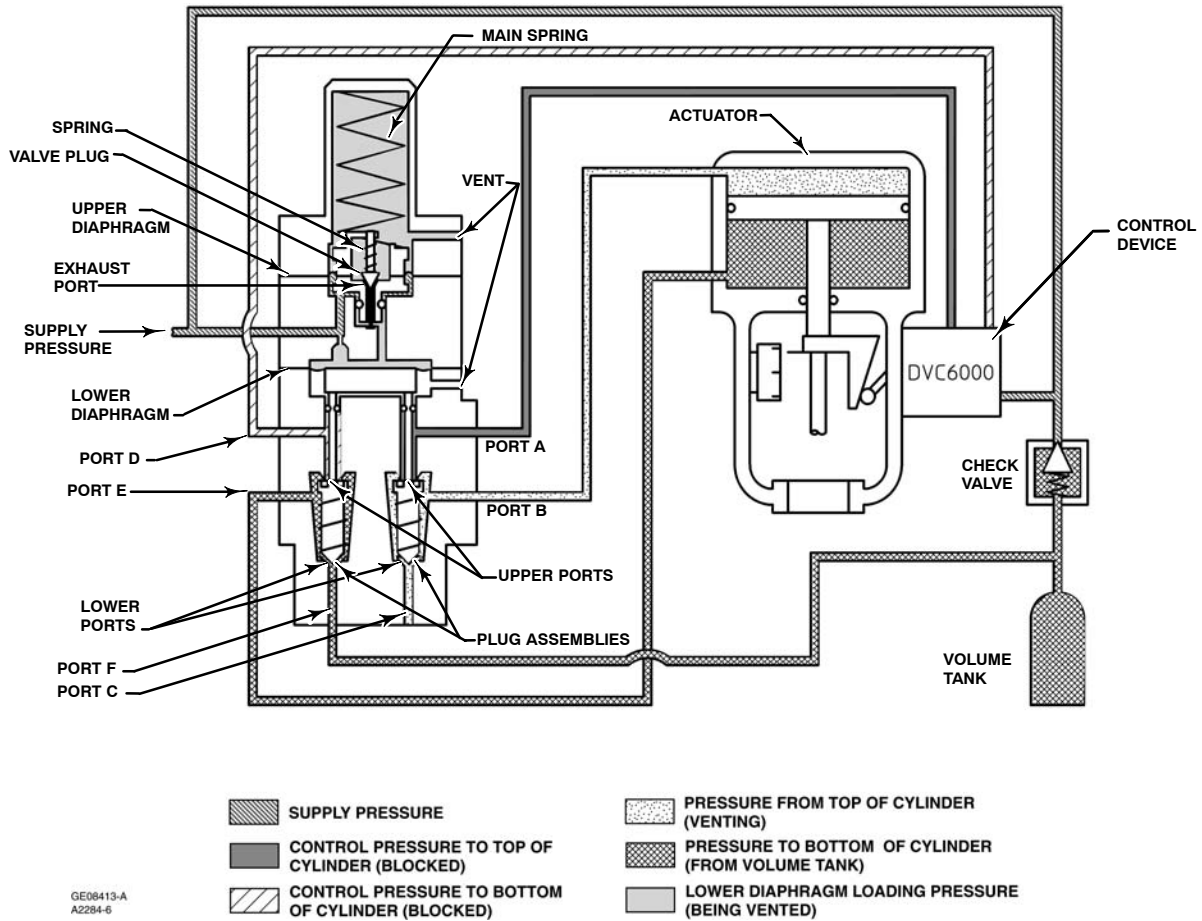

Figure 7. Type 377U Trip Valve Shown Tripped

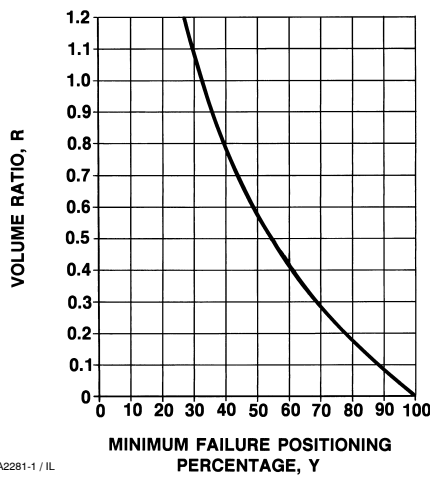

Figure 8. Volume Tank Sizing Graph

Volume Tank Sizing

Note

State and local regulations may require the use of ASME-approved volume tanks. It is the user's responsibility to determine requirements and applicable regulations for proper volume tank selection.

Seven different tanks of varying capacities are available. The volume tank must be selected so that its pressure at any time is greater than the minimum percentage of maximum supply pressure required to stroke the actuator (see figure 8).

Product Bulletin

62.3:377
May 2006

377 Trip Valve

1. Size the volume tank as indicated below:

For Actuators on Sliding Stem Valves, Determine:

$$Y = F/AP \times 100$$

For Actuators on Rotary-Shaft Valves, Determine:

$$Y = P_r/P \times 100$$

Where:

Y = Minimum failure positioning percentage

F = Actuator thrust required in normal operation to position the valve at the desired limit of travel

A = Effective piston area (from the appropriate actuator bulletin)

P = Maximum supply pressure available

P_r = Highest pressure required by the actuator to stroke the valve (from the appropriate actuator sizing technique)

2. With the minimum failure positioning percentage obtained in step 1, enter the value on the abscissa of the graph in figure 8. Locate the corresponding point on the curve, and read across to find the volume ratio, R.

3. Determine:

$$V_T = (XA)/R$$

Where:

X = Maximum actuator travel from the appropriate actuator bulletin. For rotary actuators, substitute total displacement (XA). Actuator displacement can be found in the product bulletin, or contact your Emerson Process Management sales office.

V_T = Minimum volume tank size required

R = Volume ratio from step 2

Installation

The 377 Series trip valve may be mounted in any position without affecting normal operation. Dimensions are shown in figure 9 and tables 2 and 3.

Table 1. Guidelines for Specifying 377 Series Trip Valve

Actuator Type	Fail Mode	Valve Action ⁽¹⁾	Trip Valve
Sliding-Stem	Fail Open	PDTC	377U
		PDTO	377D
	Fail Closed	PDTC	377D
		PDTO	377U
Rotary--Type 1035, Series G	Fully Clockwise	Clockwise to Close	377CW
	Fully Counter-clockwise		377CCW
Rotary--Type 1069	Fully Clockwise	- - -	377CW
	Fully Counter-clockwise	- - -	377CCW

1. PDTC—Push Down to Close; PDTO—Push Down to Open

Ordering Information

When ordering specify:

Application

1. Available supply pressure
2. Actuator type number and size
3. Input signal range
4. Operating ambient temperature
5. Trip point (If the trip point is not specified, the unit is factory-set to trip at 72 percent of supply pressure or 2.8 bar (40 psig), whichever is higher.)
6. Volume tank size

Trip Valve

Refer to the specifications. Review the information under each specification and in the referenced figures. Specify the desired choice wherever there is a selection to be made. Be sure to specify the type number as described in the Available Configurations specification.

Refer to table 1 for guidelines on specifying the correct trip valve.

377 Trip Valve

Table 2. Standard Volume Tank Dimensions

Tank Volume		J		L	
Liters	Inch ³	mm	Inches	mm	Inches
11.8	721	309	12.16	318	12.5
21.6	1315	310	12.19	451	17.75
33.4	2036	309	12.16	607	23.88
42.9	2615	309	12.16	737	29.00
65.6	4001	309	12.16	1095	43.12
131.1	8002	Requires two 65.6 liter (4001 inch ³) volume tanks			

Table 3. ASME-Approved Volume Tank Dimensions

Tank Volume		J		L	
Liters	Inch ³	mm	Inches	mm	Inches
8.5	518	208	8.19	337	13.25
24.9	1520	305	12.00	427	16.81
30.0	1831	254	10.00	684	26.94
42.8	2609	305	12.00	681	26.81
68.8	4199	360	14.19	792	31.19
71.6	4371	305	12.00	1087	42.81
143.2	8742	Requires two 71.6 liter (4371 inch ³) volume tanks			
Canadian Registered					
114	6930	406	16	1034	40.69
227	13860	508	20	1286	50.63
303	18480	610	24	1295	51.00
454	27720	610	24	1932	76.06
908	55440	Requires two 454 liter (27720 inch ³) volume tanks			

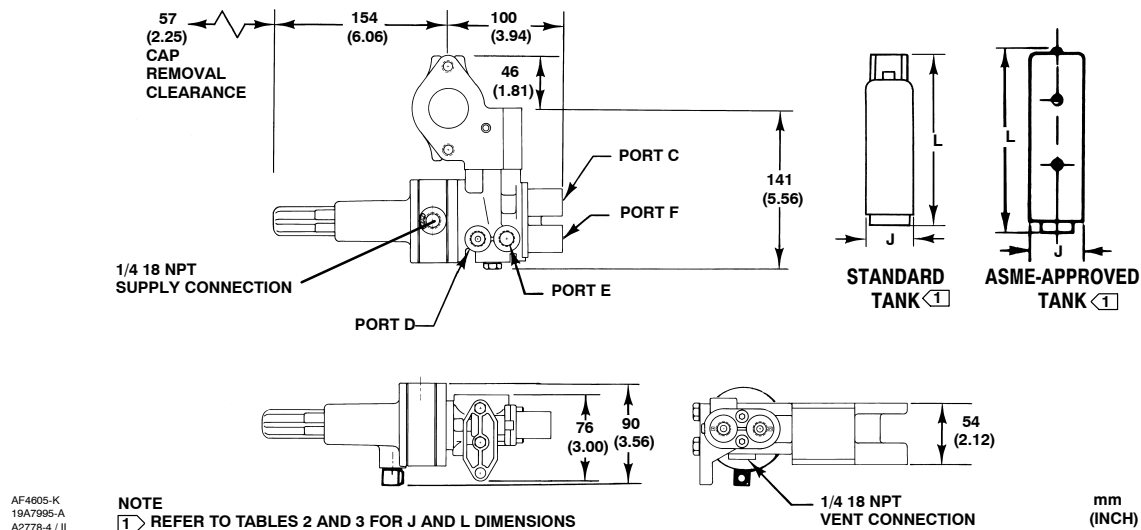

Figure 9. Dimensions of Trip Valve with Manifold (also see tables 2 and 3)

FIELDVUE and Fisher are marks owned by Fisher Controls International LLC, a member of the Emerson Process Management business division of Emerson Electric Co. Emerson Process Management, Emerson, and the Emerson logo are trademarks and service marks of Emerson Electric Co. All other marks are the property of their respective owners.

The contents of this publication are presented for informational purposes only, and while every effort has been made to ensure their accuracy, they are not to be construed as warranties or guarantees, express or implied, regarding the products or services described herein or their use or applicability. We reserve the right to modify or improve the designs or specifications of such products at any time without notice.

Neither Emerson, Emerson Process Management, Fisher, nor any of their affiliated entities assumes responsibility for the selection, use and maintenance of any product. Responsibility for the selection, use and maintenance of any product remains with the purchaser and end-user.

Emerson Process Management

Fisher

Marshalltown, Iowa 50158 USA
Cernay 68700 France
Sao Paulo 05424 Brazil
Singapore 128461

www.Fisher.com

