

Figure 16 3300 XL 8 mm Proximity Probes, Reverse Mount 4, 7

330105 and 330195, 3/8-24 UNF-2A threads

330106 and 330196, M10X1 threads

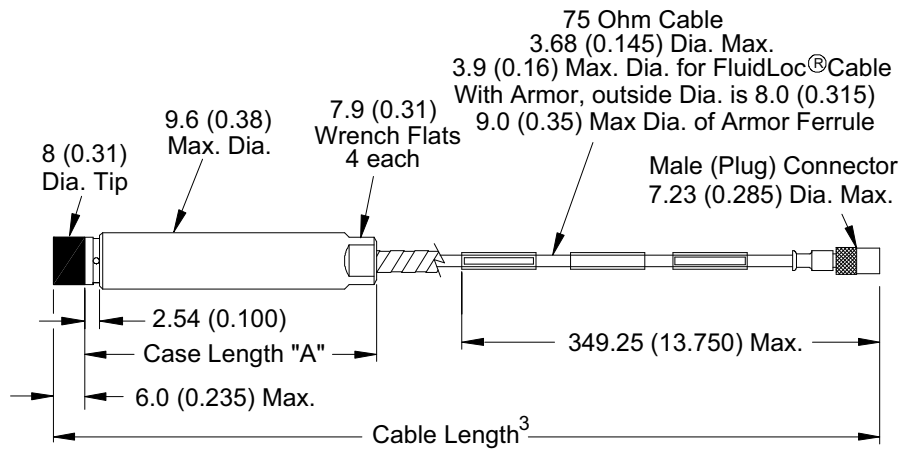

Figure 17 3300 XL 8 mm Proximity Probes, Smooth Case

330140 and 330197, without armor 7

330141 and 330198, with armor 6

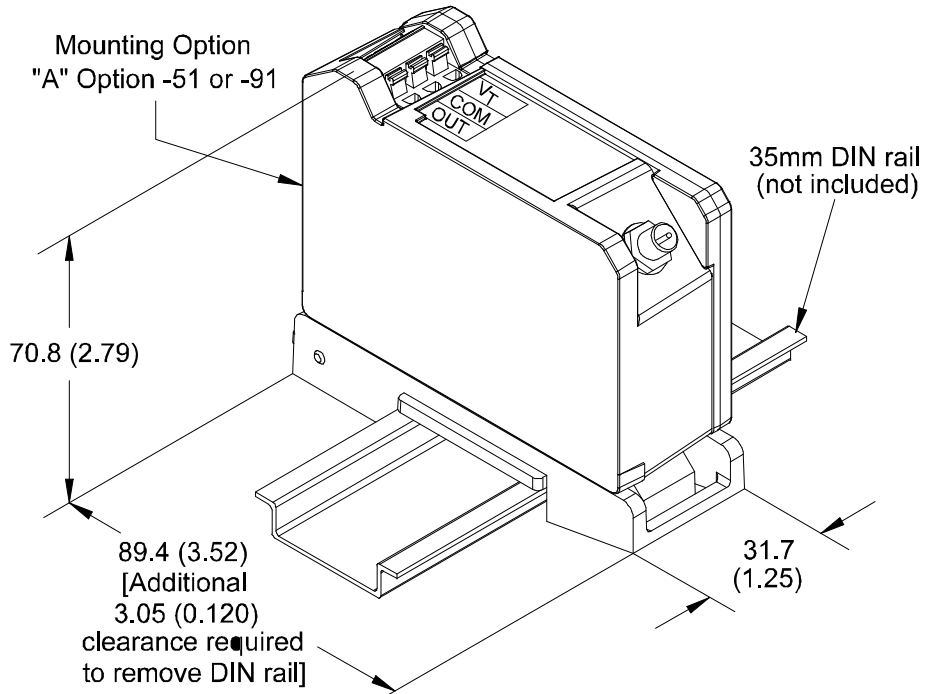

Figure 20 DIN Mount 3300 XL Proximity® Sensor