

Technical Review

Developments for Plugging Heat Exchangers in Urea Plants Pop-A-Plug® eliminates welding, reduces downtime and increases safety and reliability.

A.G.C.M. (Ron) de Rijk, EST Group B.V., The Netherlands

EST Group has developed Pop-A-Plug in urea-grade materials for sealing leaks in urea plant heat exchangers. The design incorporates a Virgin Teflon® O-ring to achieve the best possible seal between Pop-A-Plug and the weld overlay of the tube sheet. This paper will describe the detailed design features, test results and references of this revolutionary innovation in the urea industry.



(Fig 1 Pop-A-Plug with Virgin Teflon O-Ring)



(Fig 2 Non Urea specific installation of Pop-A-Plug)

EST Group has in the last years developed its Pop-A-Plug system (a mechanical tube plug to seal leaking or degraded high pressure heat exchanger tubes, widely used in the Nuclear and Fossil Power Generation industry) for use in Ammonia plants.

It provides a fast and simple way to install a mechanical tube plug with installed stability better than a welded plug. This development successfully incorporated the use for ASTM A-182 F22 Class 3 and ASTM A-182 F11 Class 2 materials. In Ammonia plants, it is common knowledge that welded plugs in high pressure service are prone to leaking problems due to stress cracking as the proper quality of the welds is difficult to assure. Moreover, welded plugs require time consuming pre-heat and post weld heat treatment, which can be eliminated by utilizing POP-A-PLUGs for repair.

During the development of Ammonia POP-A-PLUG there were questions raised if the design technology could be extended also towards the UREA service specifically for HP Strippers and Condensers.

Following some extensive discussions with industry experts in this field, EST Group decided to dedicate a significant part of its research and development time to this project.

Technical Review

Developments for Plugging Heat Exchangers in Urea Plants Pop-A-Plug® eliminates welding, reduces downtime and increases safety and reliability.

Data Collection:

It was evident there were requirements in UREA service which were more stringent than what was developed for the Ammonia Service. This required us EST Group to first analyze the requirements, summarized as follows:

- Ø 25.0 mm x 2.5 mm Tubes.
- Ø 31.0 mm x 3.0 mm Tubes.
- Ø 32.0 mm x 3.0 mm Tubes.
- Operating Pressure : 190 BarG (2755 PsiG).
- Operating Temperature : 225 °C (437 °F).
- Tube sheet with clad overlay.
- Tubes expanded only in clad overlay.
- Crevice corrosion issues relative to material selection.
- Variety of tube materials and clad overlays.

Review of Current Plugging Methodology

The traditional tube sealing methodology is welding plugs in place, which poses the following issues:

- Time consuming procedure.
- Purchase of certified material required.
- Machining to proper dimensions.
- Service of Qualified welders.
- Preparation work
- Make positive leak (pierced to provide for venting or draining).
- Weld layer 1 (first weld made).
- Primary weld quality tests.
- Weld layer 2 (second weld made).
- Secondary weld quality tests.

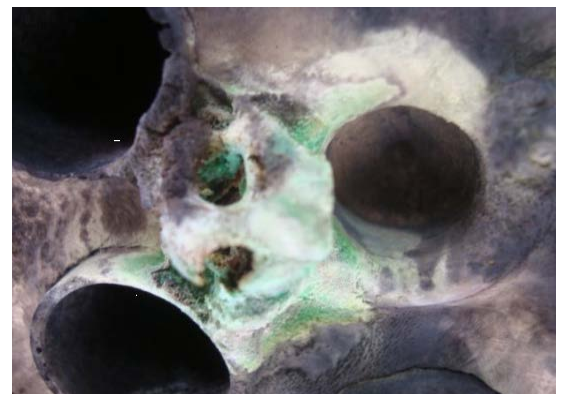

(Fig 3 Welding issues tube to tube sheet)

Furthermore, it is extremely difficult to guarantee weld quality due to:

- Difficult weld positions.
- Risk of damaging surrounding tube ends.
- Risk of porosities & worm holes due to moisture (especially bottom side on vertical tubes).
- Repeated heat input (original tube to tube sheet weld in combination with weld layer 1 followed by weld layer 2)

Technical Review

Developments for Plugging Heat Exchangers in Urea Plants Pop-A-Plug® eliminates welding, reduces downtime and increases safety and reliability.

Review of typical Pop-A-Plug Operation.

The Pop-A-Plug system eliminates the need for welding in plugs, and is a proven long-term performer in nuclear power stations as well as within chemical plants and refineries worldwide. The Pop-A-Plug heat exchanger tube plugging system is the only plug that features patented internally serrated rings designed to maintain a leak-tight seal under extreme thermal and pressure cycling.

The Pop-A-Plug is installed using a controlled force, this protects against damage to tube sheet ligaments and the adjacent tube to tube sheet joints, extending the life of your heat exchanger and minimizing re-work or repair when it's time to re-tube the heat exchanger.

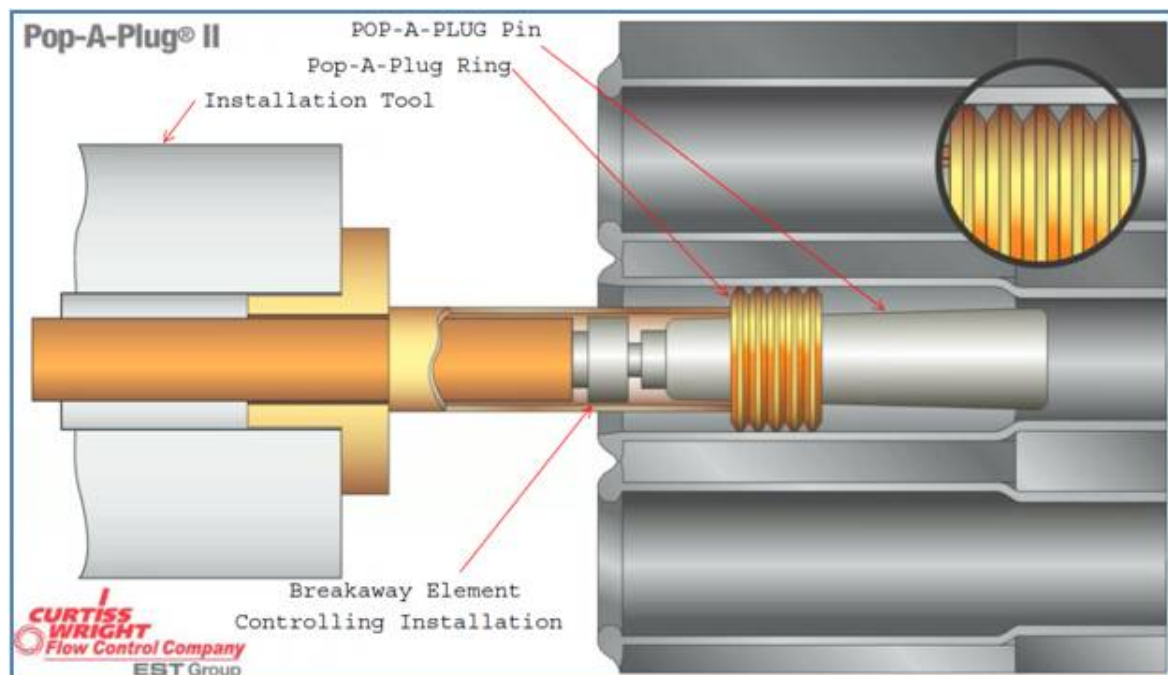

(Fig 4 Typical Pop-A-Plug Installation in the tube)

Technical Review

Developments for Plugging Heat Exchangers in Urea Plants Pop-A-Plug® eliminates welding, reduces downtime and increases safety and reliability.

Review of Pop-A-Plug® in Urea Service

Typically, a Pop-A-Plug is fitted inside the tube it needs to seal and is mechanically expanded to create a seal. However, we learned that for UREA service the tubes are typically only mechanically expanded in the weld overlay section of the tube sheet (for example UNS S31050 / X1CrNiMoN25-22-2).

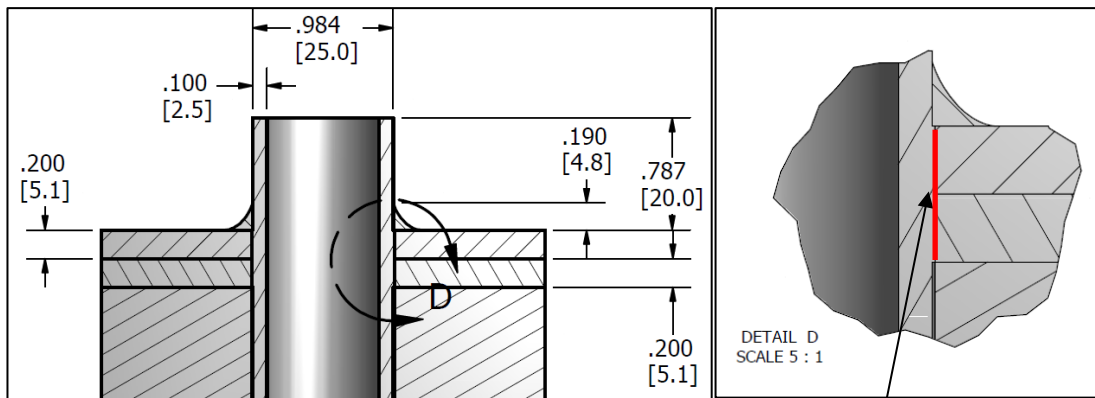

(Fig 5 Typical \varnothing 25.0 mm x 2.5 mm Tube Sheet Arrangement)

(Fig 6 Tube only expanded as indicated in red)

This established the installation location of the plug as a plug requires the support of the tube sheet to be installed correctly. In order to base the application on the worst case scenario it was decided to assume a complete tube removal from the tube sheet as shown below.

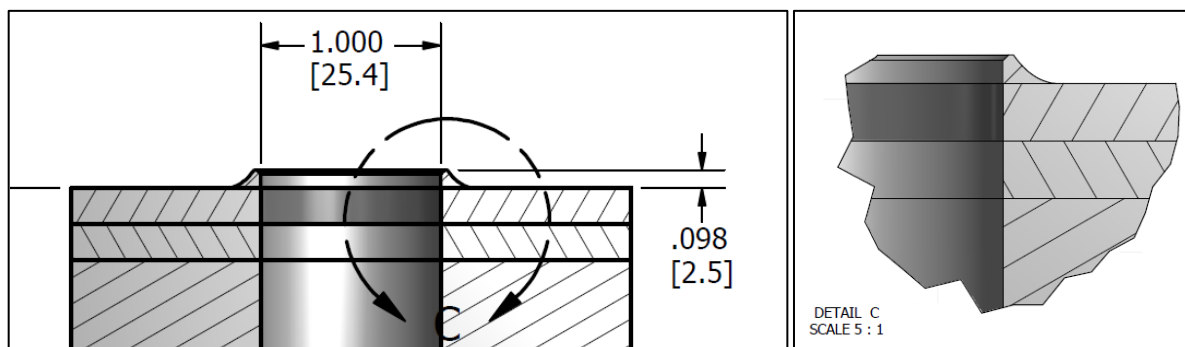

(Fig 7 Tubes removed from Tube sheet 25.0 x 2 mm)

(Fig 8 Detail C of Fig 7)

Based on the tube sizes cited earlier in this paper, three (3) different Pop-A-Plug sizes were developed for testing :

- P2-1004-Q (Q Denominates Material Code)
- P2-1254-Q (Q Denominates Material Code)
- P2-1316-Q (Q Denominates Material Code)

Technical Review

Developments for Plugging Heat Exchangers in Urea Plants Pop-A-Plug® eliminates welding, reduces downtime and increases safety and reliability.

The actual installation of the plug sealing in the clad overlay of the tube sheet is shown as per below.

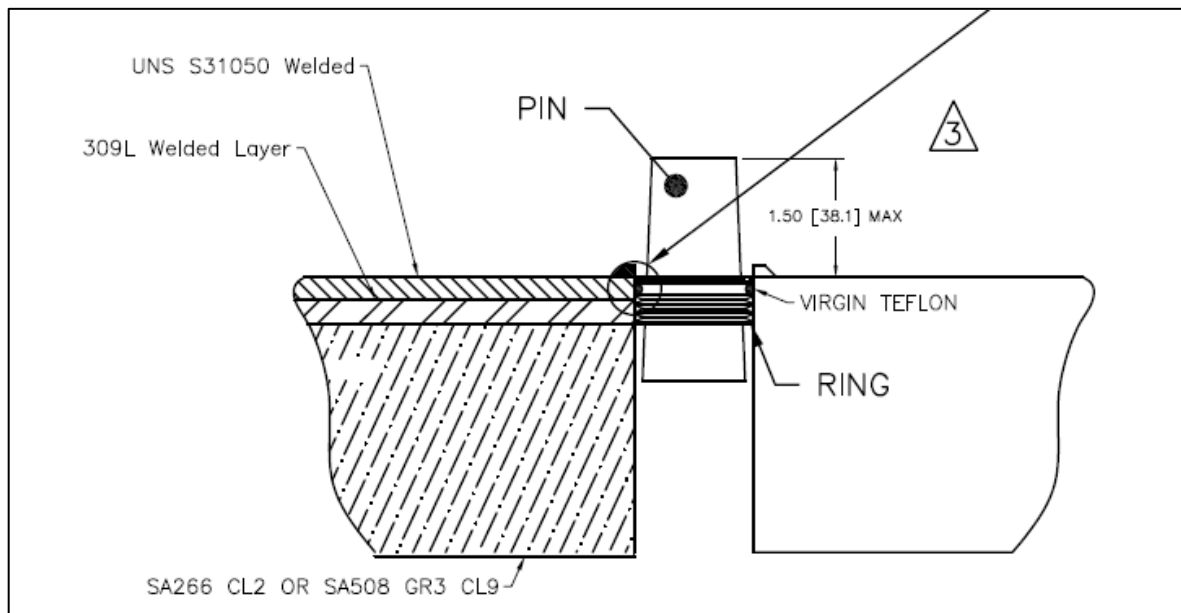

(Fig 9 Typical Urea service Pop-A-Plug installation in weld clad overlay)

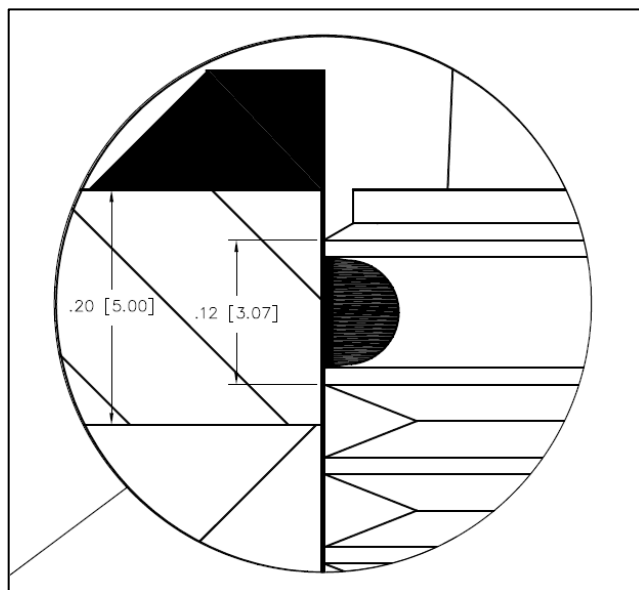

(Fig 10 Detail of Fig 9)

Technical Review

Developments for Plugging Heat Exchangers in Urea Plants Pop-A-Plug® eliminates welding, reduces downtime and increases safety and reliability.

Materials

The following three (3) grades of materials were used during the development.

- 1) Duplex SS (For initial testing but not for actual application).
- 2) *Proprietary (*Special grade of material under Secrecy Agreement).
- 3) Zirconium (Grade frequently used in Nuclear and Chemical Service)

Testing

Four (4) coupons were provided by Schoeller-Bleckmann Nitec, Austria, as samples of an 'as built' tube sheet with original tubes welded in and then removed by drilling them out.



(Fig 11 Coupon as provided)



(Fig 12 Coupons as provided)

These size Pop-A-Plugs with virgin Teflon O-Rings were manufactured and tested, and test coupons were machined to connect to the test stand fixtures.



(Fig 13 Three sizes Pop-A-Plug as manufactured)



(Fig 14 Machined test coupon with Pop-A-Plug)

Technical Review

Developments for Plugging Heat Exchangers in Urea Plants Pop-A-Plug® eliminates welding, reduces downtime and increases safety and reliability.

The testing program encompassed the following criteria:

- ✓ Helium leak testing (pre temperature cycling) sealing characteristics of plug in tube sheet sample coupons.
- ✓ Temperature cycling under maximum design pressure to simulate plant operation.

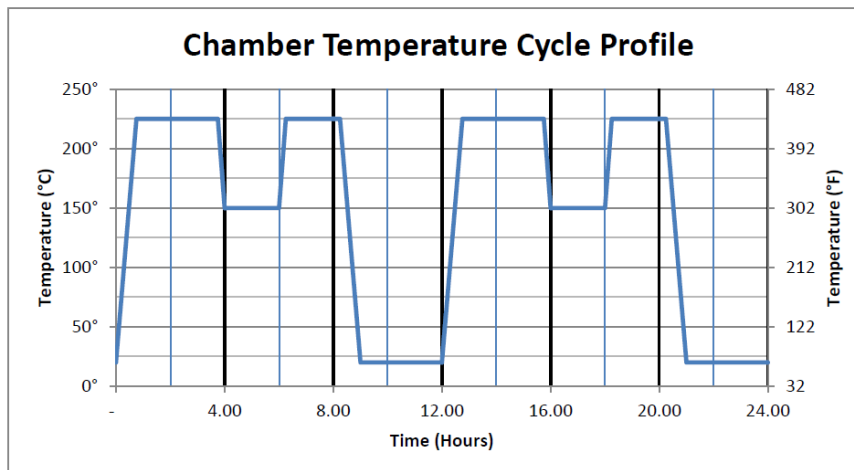

(Fig 15 Temperature Cycling Profile)

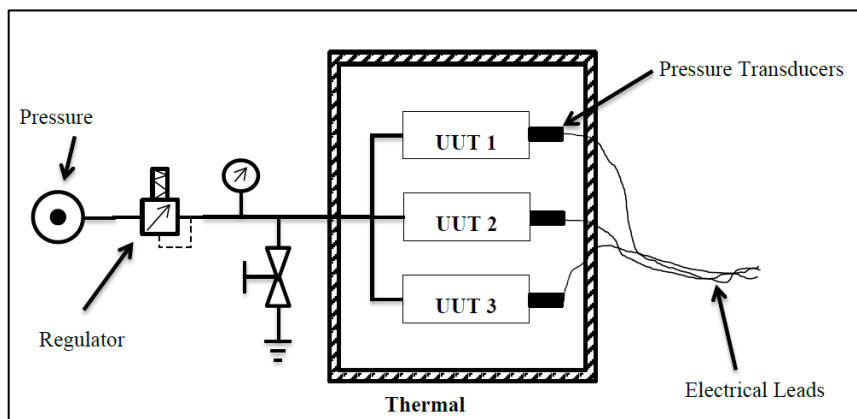

(Fig 16 Temperature Cycling arrangement)

- ✓ Helium leak testing (post temperature cycling) sealing characteristics of plug tube sheet sample coupons.
- ✓ Performance test (post temperature cycling) by means of proof pressure testing to 1.5 x design pressure at 285 BarG (4154 PsiG).

Technical Review

Developments for Plugging Heat Exchangers in Urea Plants Pop-A-Plug® eliminates welding, reduces downtime and increases safety and reliability.

Conclusions:

EST has shown it is possible to manufacture Pop-A-Plugs in materials, with temperature and pressure ratings as required, for Urea service. The Pop-A-Plugs tested, successfully passed the qualification tests. Detailed test reports and results can be made available, subject to the conditions of confidentiality agreements in place. EST Group is actively seeking further involvement of licensors and licensees to further finalize actual implementation of this technology.

Procedure to follow :

- ✓ EST Group will always extensively review every application for Pop-A-Plugs in detail prior to any proposal made.
- ✓ EST Group supplies installation tools and provides training for the installation of Pop-A-Plugs. EST Group also has experienced and certified Pop-A-Plug installation companies available to perform or assist with your repair.

Please contact us for your specific requirements and our team of experts will be ready to assist you.

Sincerely,



A.G.C.M.(Ron) de Rijk
Director EMEA Sales & Operations