

| | | |
|---|---------------------------------|------------------------|
|  <p>Johnson Controls</p> | INDOOR AIR HANDLING UNIT | |
| INSTALLATION, OPERATION & MAINTENANCE | Supersedes: 102.19-NOM1 (1012) | Form 102.19-NOM1 (813) |

MODEL AMI SERIES B



Issue Date:
August 26, 2013

IMPORTANT!

READ BEFORE PROCEEDING!

GENERAL SAFETY GUIDELINES

This equipment is a relatively complicated apparatus. During installation, operation maintenance or service, individuals may be exposed to certain components or conditions including, but not limited to: refrigerants, materials under pressure, rotating components, and both high and low voltage. Each of these items has the potential, if misused or handled improperly, to cause bodily injury or death. It is the obligation and responsibility of operating/service personnel to identify and recognize these inherent hazards, protect themselves, and proceed safely in completing their tasks. Failure to comply with any of these requirements could result in serious damage to the equipment and the property in

which it is situated, as well as severe personal injury or death to themselves and people at the site.

This document is intended for use by owner-authorized operating/service personnel. It is expected that these individuals possess independent training that will enable them to perform their assigned tasks properly and safely. It is essential that, prior to performing any task on this equipment, this individual shall have read and understood this document and any referenced materials. This individual shall also be familiar with and comply with all applicable governmental standards and regulations pertaining to the task in question.

SAFETY SYMBOLS

The following symbols are used in this document to alert the reader to specific situations:



Indicates a possible hazardous situation which will result in death or serious injury if proper care is not taken.



Identifies a hazard which could lead to damage to the machine, damage to other equipment and/or environmental pollution if proper care is not taken or instructions are not followed.



Indicates a potentially hazardous situation which will result in possible injuries or damage to equipment if proper care is not taken.

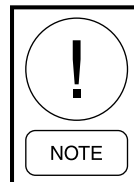

Highlights additional information useful to the technician in completing the work being performed properly.



External wiring, unless specified as an optional connection in the manufacturer's product line, is not to be connected inside the control cabinet. Devices such as relays, switches, transducers and controls and any external wiring must not be installed inside the micro panel. All wiring must be in accordance with Johnson Controls' published specifications and must be performed only by a qualified electrician. Johnson Controls will NOT be responsible for damage/problems resulting from improper connections to the controls or application of improper control signals. Failure to follow this warning will void the manufacturer's warranty and cause serious damage to property or personal injury.

SAFETY CONSIDERATIONS

WARNING

Failure to follow these instructions could result in death, serious injury or equipment damage

Follow all warnings and instructions in the unit's Manual(s).

EN Installation Instructions
for the technician / fitter

FR Manuel d'installation
pour le spécialiste / monteur

DE Installationsanleitung
für die Fachkraft / Monteur

IT Istruzioni d'installazione per
il personale specializzato

ES Guía de instalación
para el especialista del ramo

NL Installatiehandleiding
voor de vakman / monteur

SV Installationsguide
för installatör / montör

CZ Pokyny k instalaci pro
techniky a montéry

PL Instrukcja instalacji dla
technika/montera

RUS Инструкция по установке для
техника/монтажника

CN 适用于技术人员与安装人员的
安装说明书

JP 一般仕様・取扱説明書



1. Follow all applicable regulations and safety practices during rigging and lifting.
2. Prepare and follow written rigging and lifting plan.
3. Lifting must be directed by trained professional rigger.
4. Spreader bars must be used and be long enough to prevent rigging from contacting unit.
5. Use all and only designated lift points according to unit's Manual(s).
6. Locate center of gravity through trial lifts to account for possible variations in unit configuration.
7. Use rigging and lifting techniques that keep unit stable and level.
8. Keep clear of unit when lifted.

The equipment covered by this manual is designed for safe and reliable operation when installed and operated within its design specification limits. To avoid personal injury or damage to equipment or property while installing or operating this equipment, it is essential that qualified, experienced personnel perform these functions using good judgment and safe practices. *See the following cautionary statements.*



ELECTRICAL SHOCK HAZARDS. All power must be disconnected prior to installation and serving this equipment. More than one source of power may be present. Disconnect all power sources to avoid electrocution or shock injuries.



MOVING PARTS HAZARDS. Motor and Blower must be disconnected prior to opening access panels. Motors can start automatically, disconnect all power and control circuits prior to servicing to avoid serious crushing or dismemberment injuries.



HOT PARTS HAZARDS. Electric Resistance heating elements must be disconnected prior to servicing. Electric Heaters may start automatically, disconnect all power and control circuits prior to servicing to avoid burns.



Check that the unit assembly and component weights can be safely supported by rigging and lifting equipment.



All fastening devices must be designed to mechanically lock the assembly in place without the capability of loosening or breaking away due to system operation and vibration, vibration, impact or seismic events.



All assemblies must be adequately secured during lifting and rigging by temporary supports and restraints until equipment is permanently fastened and set in its final location.

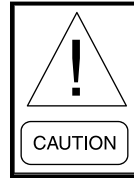

Secure all dampers when servicing damper, actuator or linkages. Dampers may activate automatically, disconnect control circuits or pneumatic control systems to avoid injury.



All unit temporary and permanent supports must be capable of safely supporting the equipment's weight and any additional live or dead loads that may be encountered. All supports must be designed to meet applicable local codes and ordinances.

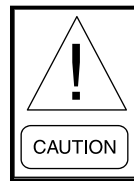

Protect adjacent flammable materials when brazing, Use flame and heat protection barriers where needed. Have fire extinguisher available and ready for immediate use.

CHANGEABILITY OF THIS DOCUMENT

In complying with Johnson Controls' policy for continuous product improvement, the information contained in this document is subject to change without notice. Johnson Controls makes no commitment to update or provide current information automatically to the manual owner. Updated manuals, if applicable, can be obtained by contacting the nearest Johnson Controls Service office.

Operating/service personnel maintain responsibility for the applicability of these documents to the equipment. If there is any question regarding the applicability of

these documents, the technician should verify whether the equipment has been modified and if current literature is available from the owner of the equipment prior to performing any work on the chiller.

CHANGE BARS

Revisions made to this document are indicated with a line along the left or right hand column in the area the revision was made. These revisions are to technical information and any other changes in spelling, grammar or formatting are not included.

TABLE OF CONTENTS

| | |
|--|-----------|
| SECTION 1 - INTRODUCTION..... | 9 |
| Inspection | 9 |
| Introduction..... | 9 |
| General..... | 9 |
| Unit Identification | 9 |
| Hand Identification..... | 9 |
| Rigging And Handling..... | 9 |
| Storage..... | 10 |
| Assembling Equipment..... | 11 |
| Gasketing | 11 |
| Mounting Actuator | 11 |
| Mixing Box..... | 11 |
| | |
| SECTION 2 - INSTALLATION | 13 |
| Installation | 13 |
| Suspended Units | 13 |
| Suspending Using Factory Base Rail | 13 |
| Suspending Using Field Supplied Supports..... | 15 |
| Internal Isolation | 15 |
| External Isolation | 15 |
| Service Clearance | 15 |
| Panel Removal..... | 15 |
| General Piping..... | 15 |
| DX Connection Steps | 16 |
| In the field:..... | 16 |
| Notes:..... | 16 |
| Condensate Drain | 16 |
| Electrical Installation..... | 16 |
| | |
| SECTION 3 - STARTUP..... | 19 |
| Electric Heat Start-Up..... | 19 |
| Before Start-Up Check | 19 |
| Start-Up | 19 |
| First Time Motor Startup..... | 20 |
| Air Balancing | 20 |
| Sheaves..... | 20 |
| | |
| SECTION 4 - PERIODIC MAINTENANCE AND SERVICE..... | 21 |
| Periodic Maintenance And Service..... | 21 |
| General..... | 21 |
| After 48 Hours of Operation | 21 |
| Weekly..... | 21 |
| Every Month | 21 |
| Every Three to Six Months | 21 |
| Every Year | 21 |

TABLE OF CONTENTS (CONT'D)

| | |
|--|-----------|
| Drain Pan | 22 |
| Inspecting and Cleaning Drain Pans..... | 22 |
| Air Filters | 22 |
| Throwaway Filters..... | 22 |
| Fans | 22 |
| Inspecting and Cleaning Fans | 22 |
| Fan Bearings..... | 23 |
| Bearing Set Screw Alignment | 23 |
| Lubricating the Fan Bearing | 23 |
| Motor | 23 |
| General Inspection..... | 23 |
| Lubrication and Bearings | 24 |
| Types of Grease..... | 24 |
| Lubrication Procedure..... | 24 |
| With Grease Outlet Plug | 24 |
| Without Grease Outlet Plug | 24 |
| Drives | 25 |
| Mounting Straight Bore Sheaves | 25 |
| Mounting Split Tapper Sheaves | 26 |
| Adjust Variable Pitched Sheaves | 26 |
| Belts | 27 |
| Adjusting Belt Tension..... | 27 |
| How to Increase Belt Life | 27 |
| Coils | 28 |
| Steam, Hot Water and Chilled Water Coils | 28 |
| Refrigerant Coils | 29 |
| Winterizing Water Coils | 29 |
| Operating Guidelines..... | 29 |
| Operating Limits | 29 |
| Vibration Levels..... | 29 |
| Vibration Causes | 30 |
| Periodic Service and Maintenance..... | 30 |
| Application Recommendation For Coils | 30 |
| General..... | 30 |
| Water Cooling Coils..... | 30 |
| Direct Expansion Coils | 30 |
| Steam Coils | 31 |
| Water Heating Coils..... | 32 |
| SECTION 5 - TROUBLESHOOTING..... | 33 |
| Temperature | 35 |

TABLE OF CONTENTS (CONT'D)

LIST OF FIGURES

| | |
|--|----|
| FIGURE 1 - Lifting Unit With Base Rails | 9 |
| FIGURE 2 - Lifting Units Without Base Rails..... | 10 |
| FIGURE 3 - Assembly, Units Without Base Rails | 11 |
| FIGURE 4 - Assembly, Units With Base Rails | 11 |
| FIGURE 5 - Gasket Application | 11 |
| FIGURE 6 - Suspended Units | 12 |
| FIGURE 7 - Hand Identification..... | 13 |
| FIGURE 8 - Remove Hold Downs..... | 14 |
| FIGURE 9 - Isolator Installation..... | 14 |
| FIGURE 10 - Drain Trap..... | 15 |
| FIGURE 11 - Mounting Sheaves | 21 |
| FIGURE 12 - Sheave Alignment..... | 22 |
| FIGURE 13 - Split Tapper Sheave Mounting..... | 22 |
| FIGURE 14 - Belt Tension | 23 |

LIST OF TABLES

| | |
|--|----|
| TABLE 1 - Minimum Hex Head Bolt Torque In Lb-Ft - Grade 5 Bolt..... | 18 |
| TABLE 2 - Recommended Greasing Intervals Of Fan Bearings..... | 19 |
| TABLE 3 - Recommended Greases For Various Operating Ranges | 20 |
| TABLE 4 - Fan Bearing Maximum Grease Capacity..... | 20 |
| TABLE 5 - Recommended Motor Greasing Schedule | 21 |
| TABLE 6 - Determining Deflection Force | 25 |
| TABLE 7 - Forward Curve Fan Data | 26 |
| TABLE 8 - Vibration Levels | 26 |
| TABLE 9 - AMI Troubleshooting Analysis..... | 29 |

THIS PAGE INTENTIONALLY LEFT BLANK.

SECTION 1 - INTRODUCTION

INSPECTION

Upon receipt of equipment, carefully check all items against the bill of lading to ensure that all equipment has been received. Note any discrepancy on the bill of lading before signing.

Inspect all equipment for any signs of damage caused during transit. Note any visual damage on the bill of lading before signing. Immediately report all visual and concealed damage to the carrier and file a claim.

INTRODUCTION

General

In order to ensure long and trouble free life, the equipment should have proper care and maintenance. Enough space should be left around the unit for service and repair, see *Installation on page 13*

Equipment, as shipped, is factory assembled as far as job specifications and shipping limitations allow. Where field assembly is required, bolts, nuts, screws and gasketing material are provided with each module. Modules bolt together from the inside of the upstream module.

UNIT IDENTIFICATION

To ensure the assembled AMI modules are in the proper sequence, each module has an identifying code and an airflow direction label. The proper assembly sequence is listed on the supply fan nametag. The first listed module is the first section in the direction of airflow.

HAND IDENTIFICATION

Coil connections and other components are located and described as left or right hand. The proper orientation to describe the proper hand is when airflow is at your back. Vertical stacked top sections maintain the same handling as lower section. See *Figure 7 on page 14*

RIGGING AND HANDLING

The AMI air handler can ship as separate modules, fully assembled, or in separately assembled sections depending on the unit size and application. The equipment must be rigged as it was shipped from the factory. Do not remove shipping skid or protective cover until equipment is ready for final placement, as damage to equipment can result. Do not remove protective caps from piping connections until ready to connect piping.

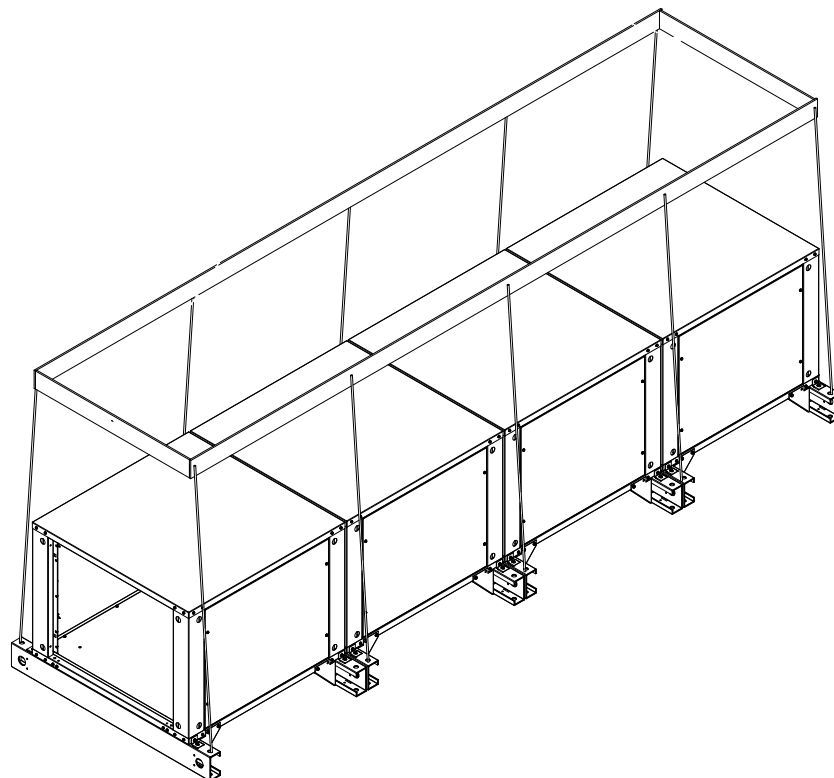

FIGURE 1 - LIFT POINTS FOR UNITS WITH BASE RAILS

Units with base rails can be rigged by means of lifting holes on the end of base rail (see *Figure 1 on page 9*).

Units without base rails must be lifted with slings. Place slings at ends and joints of modules to prevent damage to equipment (see *Figure 2 on page 10*).

Spreader bars must be used to prevent damage to equipment. Avoid twisting or uneven lifting of equipment. Do not lift equipment by coil connection or headers. See submittal drawings.

If transporting units with forklift, forks must extend the full width of unit to prevent damage to bottom of unit.

Always take special care when handling the blower module. All fans are dynamically balanced. Rough handling may cause bearing misalignment and/or shaft damage.

STORAGE

To transfer equipment from truck to storage site, refer to *Rigging And Handling on page 9*

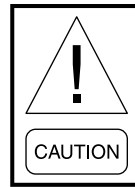

If a forklift is used, lift only from heavy end of skid.

1. Do not stack unit modules or accessories during storage. Stacking can cause damage or deformation.
2. If equipment is to be stored for more than two weeks prior to installation, observe the following precautions:
 - a. Choose a dry storage site that is reasonably level and sturdy to prevent undue stress or permanent damage to the equipment structure or components. Do not store equipment on vibrating surface. Damage to stationary bearings can occur. Set equipment off ground if in moisture prone areas.

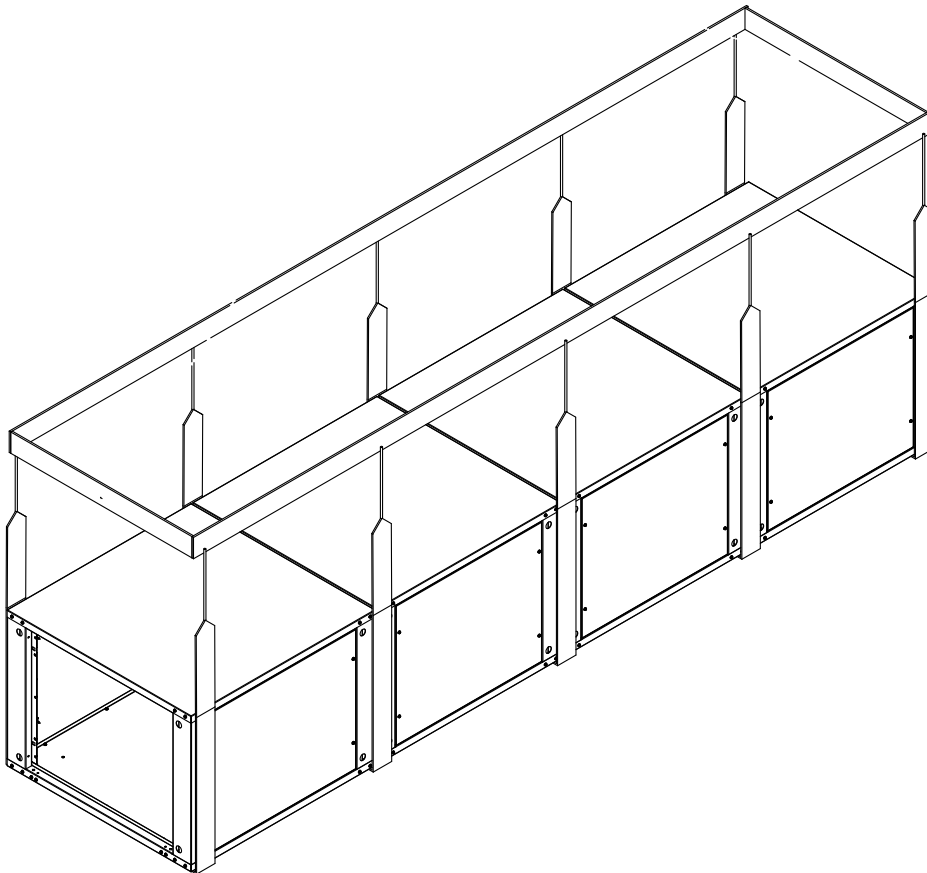

FIGURE 2 - LIFT POINTS FOR UNITS WITH BASE RAILS

- b. Remove all shipped loose parts from job site to minimize theft. Tag and store parts in a safe place until needed.
- c. Cover entire equipment with protective tarp or moisture proof cover. Extend cover under equipment if stored on ground. Secure cover with adequate tie downs or store indoors. Be sure that all piping connections have protective shipping caps installed.
- d. Monthly - remove cover from unit, open fan access panel, remove belt ties and rotate fan and motor slowly by hand to redistribute the bearing grease and prevent bearing corrosion.

ASSEMBLING EQUIPMENT

All modules ship with the required bolts, nuts, screws and gasket material to assemble the equipment. Bolt/screw holes are accessible through the inside of the upstream module (*Figure 3 on page 11, Figure 4 on page 11*).

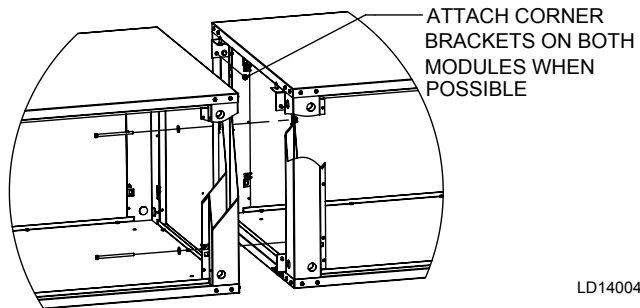

FIGURE 3 - ASSEMBLY, UNITS WITHOUT BASE RAILS

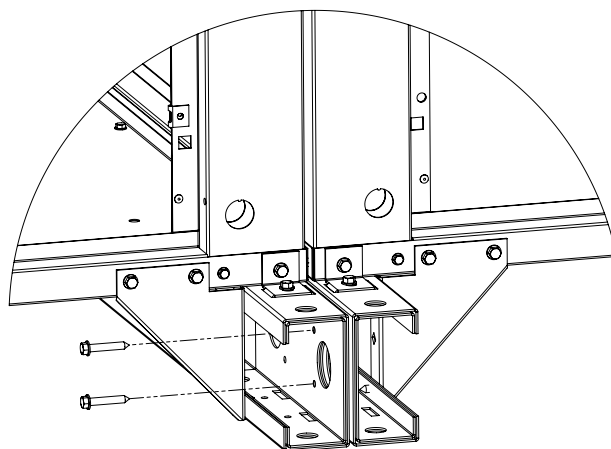

FIGURE 4 - ASSEMBLY, UNITS WITH BASE RAILS

Gasketing

The gasketing material is supplied with each module for sections that need to be assembled on the job site.

Gasket the perimeter of each module. Overlap the gasketing approximately 1/8" when splicing. This will prevent air leakage between modules (*see Figure 5 on page 11*).

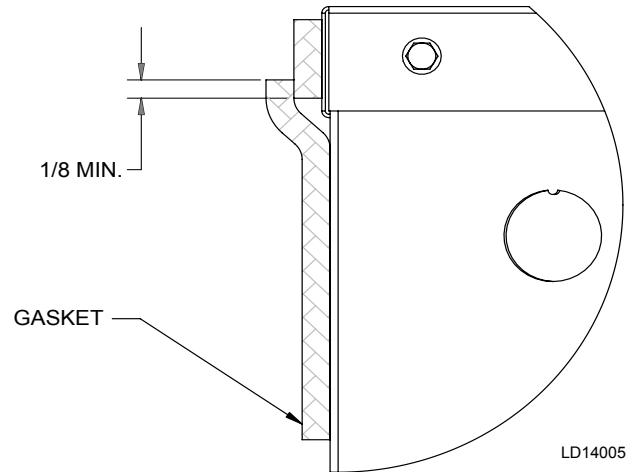

FIGURE 5 - GASKET APPLICATION

Mounting Actuator

The Installing contractor takes all responsibility for the mounting of all field installed actuators. No requirements are made for the position of these actuators due to the number of options and arrangements available and the assortment of specific applications.

Attention should be taken to insure proper actuator support to prevent unnecessary stress in the linkage, cabinet, or damper shaft. Multiple damper assemblies must not be actuated from the shaft extension opposite the connection link.

Mixing Box

Fresh air and return air dampers can be connected together and driven from the same actuator if the dampers are the same size. If the dampers are different sizes they must be driven by individual actuators and controlled separately.

THIS PAGE INTENTIONALLY LEFT BLANK.

SECTION 2 - INSTALLATION

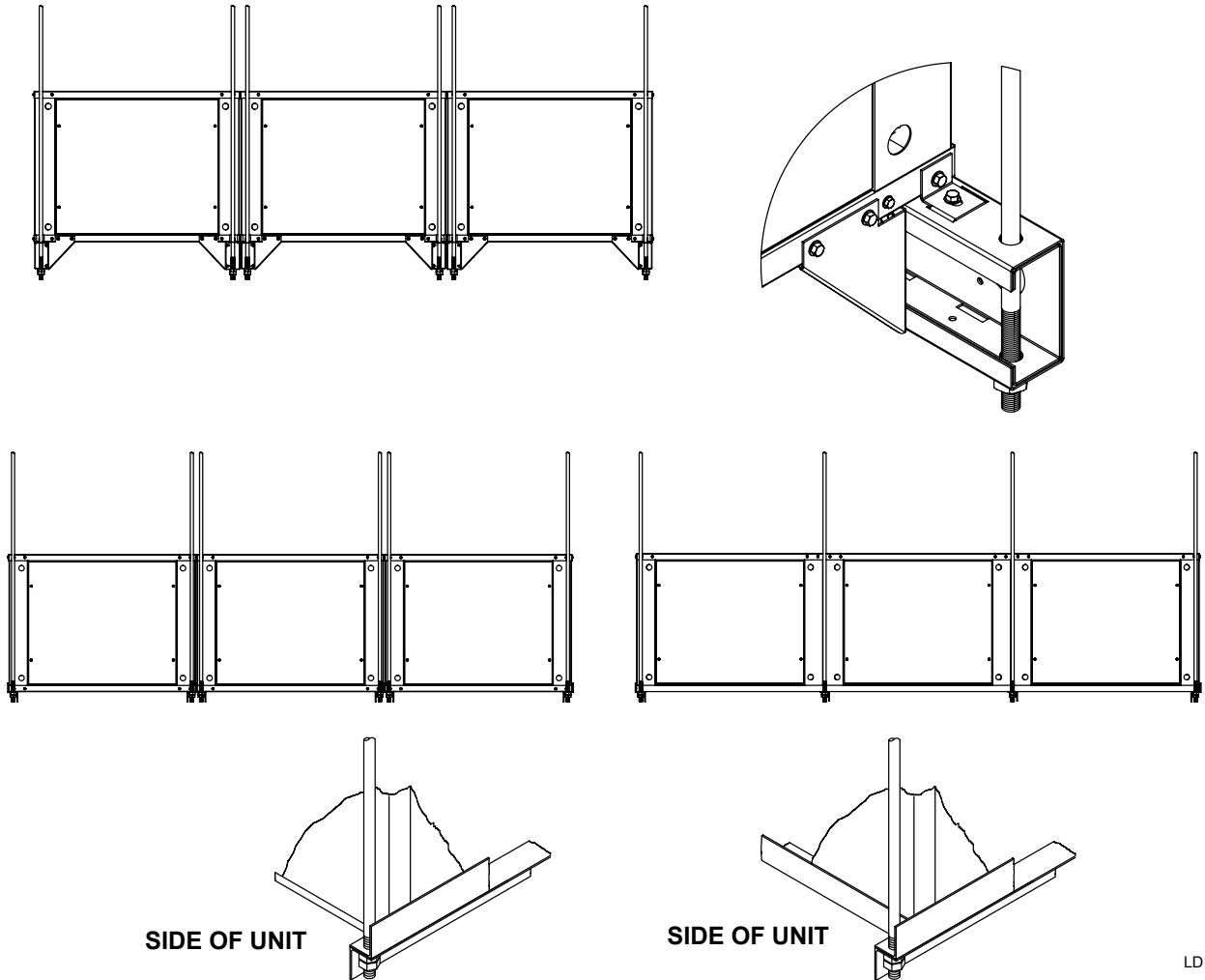

FIGURE 6 - SUSPENDED UNITS

LD14006

INSTALLATION

This equipment must be installed in strict accordance with any applicable local, state, and national codes including but not limited to building, electrical, and mechanical codes. On single wall equipment, lay rigid temporary protection, such as plywood, inside of equipment to protect insulation during installation.

Suspended Units

When the equipment is to be suspended from a ceiling, a base rail, angle iron, or channel must support the equipment. The AMI product line is not designed to be suspended from the top of the equipment. Before hanging the equipment, all field assembly must be completed.

Suspending Using Factory Base Rail

The factory optional base rails have a 5/8" diameter hole located in each corner for hanger rods. A hanger rod must be installed in each corner of a module to properly support the equipment and maintain unit's structural integrity.

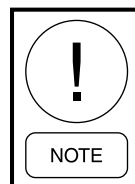

Hanger rods must be located so that they do not interfere with access panels.

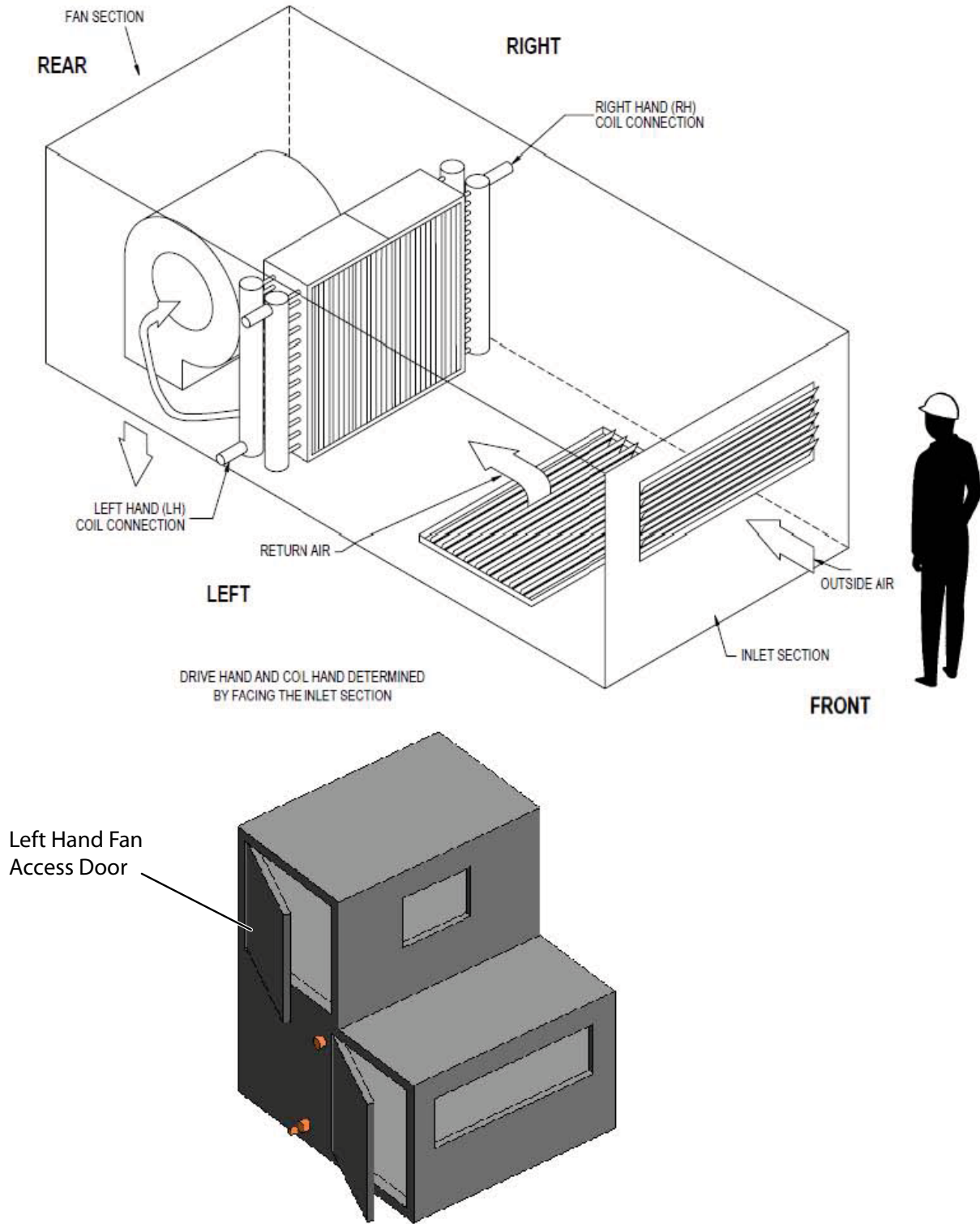

FIGURE 7 - HAND IDENTIFICATION

Suspending Using Field Supplied Supports

All field supplied structural supports must be designed to support entire unit weight including all appurtenances, motor, drives, and all live or dead loads. All supports must be designed to meet applicable local codes and ordinances. Each module must be supported with an angle iron or channel. The angle iron or channel must cover the width and length of the equipment base and must be designed to mechanically lock the unit to the field supports (see *Figure 6 on page 13*).

Internal Isolation

Equipment may be supplied with internal spring isolation. If so, removal of shipping hold-downs is required before equipment start-up (see *Figure 8 on page 15*).

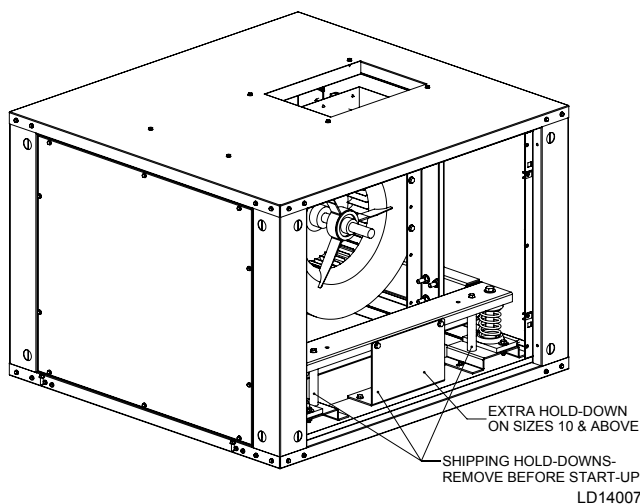

FIGURE 8 - REMOVE HOLD DOWNS

External Isolation

Install vibration isolators (see *Figure 9 on page 15*) in accordance with the job specifications and the instructions of the isolator manufacturer base. Base rails are required for external isolation. If the coil module is also isolated, the piping must be isolated or have a flexible connection to prevent coil header damage due to equipment movement. All piping, wiring, ductwork and external connections must be isolated.

Service Clearance

Access to at least one side of the equipment is required for routine service, maintenance and repair. Consideration should be given to fan shaft, coil, filter removal, motor, fan, bearings, and damper linkage access. Clearance must meet or exceed applicable local and national codes.

Panel Removal

To remove access panels, loosen the four retaining screws and lift panel off. Alternately, lift off hinges with quick turn fasteners.

General Piping

All pipe connections need to be supported independently from the header. Failure to do so may cause cracking at the headers. All piping shall be in accordance with local codes and follow accepted industry standards. DX coil distributor cap for test and nitrogen charge must be removed before mounting TXV. All coil connections are stubbed out of cabinet panel with the exception of refrigerant (DX) coils. Field penetration of panels is required for liquid line piping.

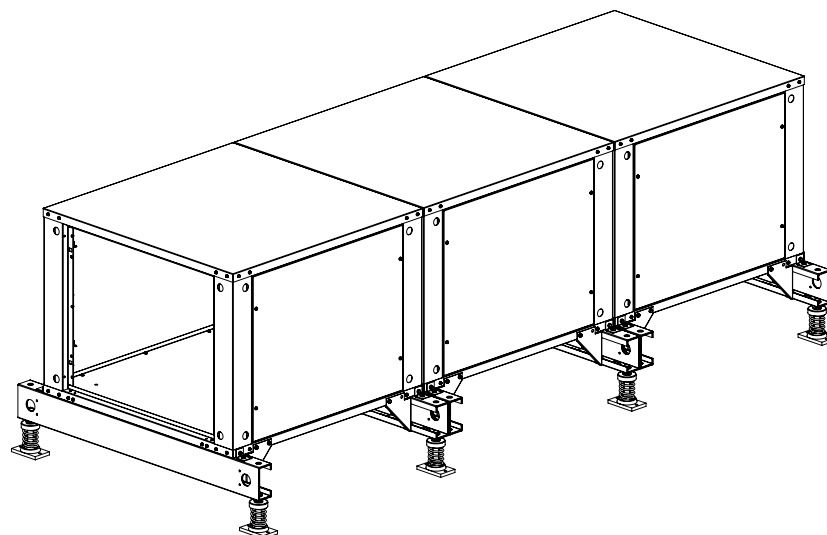

FIGURE 9 - ISOLATOR INSTALLATION

DX CONNECTION STEPS

In the field:

1. Purge the system by pressing the Schrader valve.
2. Heat the soft solder and remove the Schrader valve and flare.
3. Attach thermal expansion valve (TXV) to distributor.

Notes:

- DX coils are shipped capped and sealed with a Nitrogen holding charge.
- Distributors are not used if only one refrigerant feeder tube provided.
- Fixed orifice metering devices, as supplied, are based on nominal capacity and may not meet the needs of the system.
- TXV's are the advised method of refrigerant regulation into the coil.
- If a TXV is field installed the fixed orifice must be removed prior to TXV installation. TXV's
- All pipe connections need to be supported independently from the header. Failure to do so may cause cracking at the headers. All piping shall be in accordance with local codes and follow accepted industry standards. DX coil distributor cap for test and nitrogen charge must be removed before mounting TXV.
- These coils may be used in systems with hot gas bypass or heat pump condensing units, but require the addition of fittings or refrigerant specialties to be furnished and installed by others.

Condensate Drain

All condensate drains must have a trap installed. This will prevent excessive condensate buildup and/or condensate overflow. To ensure that the trap remains sealed the trap depth and the distance between the pan outlet and the trap outlet should be the total static pressure of the unit plus one inch (see *Figure 10 on page 16*).

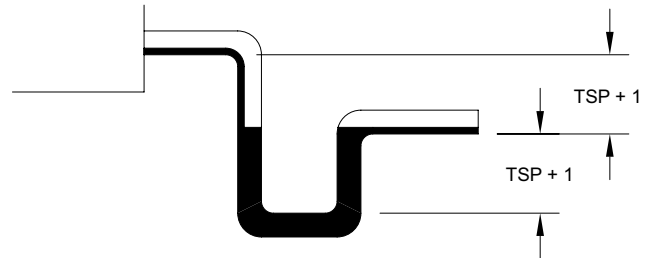

FIGURE 10 - DRAIN TRAP

Electrical Installation

1. The Electrical service to the fan must be compatible to the rated voltage on the motor nameplate, and be in accordance with local codes.
2. The Fan segments metal casing must be connected to the buildings electrical ground on isolated units.
3. Door electrical interlock is not offered.
4. Some motors have internal automatic reset overload protection.
5. Thermal motor protection is external to the unit. Thermal protection and a disconnect switch are provided by others.
6. Review wiring diagram and make necessary connections accordingly.

| | | |
|---|--|-----------------------|
|  | <h2 style="margin: 0;">INDOOR AIR HANDLING UNIT</h2> | |
| INSTALLATION CHECKLIST | New Release | Form 102.19-CL1 (813) |

INSPECTION AND STARTUP CHECKLIST

The following work must be completed in accordance with installation instructions found in Form 102.19-NOM1.

A. RECEIVING & INSPECTION

- 1. Unit Received Undamaged
- 2. Unit Arrangement/Hand Correct
- 3. Unit Received Complete As Ordered.....
- 4. Unit Structural Support Complete & Correct.....

B. HANDLING & INSTALLATION

- 1. Unit Mounted Level & Square
- 2. Proper Electrical Service Provided
- 3. Proper Service Switch/Disconnect Provided.....
- 4. Proper Chilled Water Line Size To Unit
- 5. Proper Refrigerant Line Sizes To Unit
- 6. Proper Steam Condensate Trap On Return Line.....
- 7. All Services To Unit In Code Compliance
- 8. Proper Access Provided For Unit & Accessories.....
- 9. Proper Overcurrent Protection Provided.....
- 10. Confirm No Debris Is Left In The Electric Heat Section
- 11. Proper Hot Water Line To Unit.....
- 12. Proper Steam Line Sizes To Unit.....
- 13. Proper Steam Supply Pressure To Unit (15psi Max)
- 14. All Shipping Screws & Braces Removed
- 15. Damper Linkage Is Tight And In Correct Position.....
- 16. Install Per Seismic IOM As Required.....
- 17. All Shipped Loose Parts Installed

- 18. Installer Has Cleaned Out Interior.....
- 19. Clean Air Filter Installed.....

C. COOLING/HEATING CONNECTIONS

- 1. Protect Valve Package Components From Heat
- 2. Connect Field Piping To Unit
- 3. Install Drain Line & Traps As Required.....
- 4. Install Condensate Pan Under Piping As Required .
- 5. Mount Valve Packages
- 6. Pressure Test All Piping For Leaks.....
- 7. Insulate All Piping As Required.....

D. DUCTWORK CONNECTIONS

- 1. Install Ductwork, Fittings & Grilles As Required.....
- 2. Control Outside Air For Freeze Protection.....
- 3. Proper Supply & Return Grille Type & Size Used....
- 4. Insulate All Ductwork As Required.....
- 5. Verify All Ductwork Is Complete, Dampers, And Filters Are Installed Prior To Startup.....

E. ELECTRICAL CONNECTIONS

- 1. Refer To Unit Wiring Diagram.....
- 2. All Field Wiring In Code Compliance
- 3. Connect Incoming Power Service or Services.....

F. UNIT STARTUP

1. General Visual Unit & System Inspection
2. Record Ambient Temperature.....
3. Close All Unit Isolation Valves
4. Fill Systems With Water/Refrigerant
5. All Ductwork & Grilles In Place
6. Start Fans, Etc.
7. Check All Ductwork & Units For Air Leaks
8. Record All Final Settings For Future Use
9. Check All Dampers For Proper Operation
10. Verify Proper Heating Operation.....
11. Check All Piping For Leaks
12. Record Electrical Supply Voltage.....
13. Check All Wiring For Secure Connections.....
14. Flush Water Systems
15. Vent Water Systems As Required
16. All Unit Panels & Filters In Place
17. Check For Overload Condition Of All Units.....
18. Balance Air Systems As Required.....
19. Check Piping & Ductwork For Vibration.....
20. Verify Proper Cooling Operation.....
21. Reinstall All Covers & Access Panels.....
22. Check Unit Drain Pan To Confirm trap Is Free To Drain And That Unit Drain Pan Does Not Hold Water.

G. BLOWER / MOTOR

1. Check Sheave Set Screw Tightness.....
2. Check Blower Wheel Set Screw Tightness.....
3. Adjust Blower Speed as Necessary for Balancing Airflow.....
4. Check / Adjust Belt Tension.....
5. Check / Adjust Sheave Alignment.....
6. Fan Wheel Properly Aligned, Tight On Shaft And Freely Moving.....
7. Fan Bearing Have Been Re-Lubricated Properly...

SECTION 3 - STARTUP

ELECTRIC HEAT START-UP



Rotating parts and electrical shock hazards exist. Lock out and tag out the fan motor(s) and heat power disconnects before servicing. FOLLOW THE LATEST "LOCKOUT TAGOUT" PROCEDURE. Failure to follow proper safety precautions may result in serious injury or death.

All electrical connections in the heater, including both field and factory made connections, should be checked for tightness before operating the heater. In addition, after a short period of operation, all connections should again be checked for tightness.



DO NOT operate electric heat below the minimum airflow requirement. Minimum airflow requirement for blow thru electric heaters is 70 CFM / KW.

A visual inspection of the heater elements should be made prior to use of the heater. If physical damage is evident, a Megohm test should be used to validate the heater elements are safe for use. If a minimum value of 10 Megohms is not achieved then any damaged elements or ceramic insulators must be replaced prior to operation.

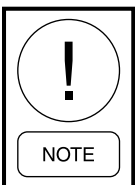

Ensure filters are clean and airflow is at minimum requirement or greater. Preferably 100% for this start up procedure.

To operate this heater make sure all associated control equipment is on, energize main supply disconnect and set controlling thermostat above ambient temperature. This heater is equipped with automatic and manual reset temperature limiting controls. If it fails to operate, make sure manual resets are operative by pushing reset buttons.

BEFORE START-UP CHECK

Thorough safety precautions should always be taken when performing startup and service. Only qualified individuals should perform these tasks.

Before entering the fan section, make sure that the fan electrical power source is disconnected, locked and tagged out in the "OFF" position.

1. Check that the unit is completely and properly installed with ductwork connected. Check that all construction debris is removed, and filters are cleaned.
2. Check that all electrical work is finished and properly terminated. Check that all electrical connections are tight and that the proper voltage is connected.
3. Motor and Ball bearings on fan shaft are pre-lubricated and do not need grease before startup.
4. Check tightness of setscrews in bearings and fan wheel(s). Make sure setscrews are torqued per Table 1. (see Table 1 on page 22)



Equipment damage due to loose setscrews or fasteners represents improper start-up and equipment abuse. It is not covered by the warranty.

5. Check tightness of sheave setscrews and/or capscrews. Check alignment of fan and motor sheaves and belt tension.
6. Rotate shaft manually by hand to make sure it is free.
7. Fan Startup: Start Fan, and observe the rotation. If the fan is operating backward, disconnect power and reverse two legs of the 3-phase supply power.
8. To ensure that water connections and joints are tight, leak test the piping systems.
9. Check that condensate drain is trapped.

START-UP

Units are not intended for temporary heat/cool or ventilation. Units are not designed or equipped to operate in dusty environments. Filters may not provide adequate protection when the unit is operated in a construction environment. Operation of the units in conditions outlined above could result in damage to the equipment or buildings and furnishings and void all manufacturer warranty.

AC power current imbalance must not exceed 2%. Be sure that the following guidelines are met:

1. AC power is within 10% of rate voltage with frequency. (See equipment nameplate for ratings).
2. AC power is within 5% of rated frequency with voltage.
3. A combined variation in voltage and frequency of 10% (sum of absolute values) of rated values provided the frequency variation does not exceed 5% of rated frequency.

FIRST TIME MOTOR STARTUP

Check to see that all power to the equipment is off. Be sure that the motor shaft is disconnected from the load, and will not cause fan rotation.

1. Make sure that the mechanical installation is secure. All bolts and nuts are tightened etc.
2. Ensure that all construction debris is removed from inside of equipment.
3. Check lubrication of fan, motor bearings and damper linkage
 - a. Note that all bearings are shipped completely full of grease for corrosion protection. Bearings may run warm temporarily on startup until excess grease has discharged.
 - b. Check tightness of bearing setscrews or locking collars. Also, check tightness of setscrews on fan wheel and sheave.
 - c. Hand operate all damper linkage, to check freedom of movement.
4. If equipment has been in storage or idle for some time, check winding insulation integrity with megger.
5. Inspect all electrical connections for proper terminations, clearance, mechanical strength and electrical continuity.
6. Be sure that all shipping materials, braces, and construction debris are out of equipment.
7. Manually rotate motor shaft to ensure that it rotates freely.
8. Replace all panels that were removed during installation.

9. Momentarily apply power and check direction of rotation of motor shaft.
10. If motor rotation is wrong, be sure power is off and change the motor lead connections, verify rotation before you continue.
11. Start motor and ensure operation is smooth without excessive vibration or noise. If so, run the motor for 1 hour with no load connected.
12. After 1 hour of operation, disconnect power and connect the load to the motor shaft. Ensure that motor is properly ventilated.

Air Balancing

When units are supplied with a variable pitch motor sheave, they are as a rule set to the mid rpm range. Field adjustment may be necessary to achieve required airflow. See *Drives on page 25* for variable pitch sheave adjustment instructions.

When the final field alterations are concluded the current draw of the motors should be checked and compared to the full load current rating of the motor. The amperage must not be above that shown on the motor nameplate.

Sheaves

Upon completion of the air balance, it is a common industry recommendation that the variable pitched motor sheave be replaced with a properly sized fixed sheave. A matching fixed sheave will provide longer belt and bearing life and vibration free operation. Initially, it is best to have a variable pitched motor sheave for the purpose of air balancing, but once the balance has been achieved, fixed sheaves maintain balance and alignment more effectively. See *Drives on page 25* for variable pitch sheave adjustment instructions.

SECTION 4 - PERIODIC MAINTENANCE AND SERVICE

PERIODIC MAINTENANCE AND SERVICE

General

The following checklist is provided as an abbreviated guide to periodic maintenance. Detailed procedural information is given after this checklist.

After 48 Hours of Operation

Belts will achieve their permanent stretch and will require re-adjustment, make sure not to over-tighten. See *Belts on page 27* for adjustment instructions.

Weekly

Observe unit weekly for any changes in running condition and unusual noise.

Every Month

- Check air filters. Clean or replace if clogged or dirty.
- Re-lubricate fan bearings if operating conditions include high speeds, moist or dirty air, or high temperatures.
- Re-lubricate motor bearings in accordance with motor manufacturer's recommendations if operating conditions include high speed, moist or dirty air, or high temperatures. See motor label (*Motor on page 23*).
- Check and adjust fan belt tension.

Every Three to Six Months

- Check fan bearing grease line connections. Lines should be tight to the bearings.
- Re-lubricate fan bearings.
- Check motor lubrication. Recommendations are provided on the motor label.
- Check bearing and motor bracket bolt torque (see *Table 1 on page 22*).
- Align fan and motor sheaves. Tighten sheave setscrews to the proper torque (see *Table 1 on page 22*).
- Check and adjust fan belt tension.
- Tighten electrical connections
- Inspect coils for dirt build-up or coil freeze-up.

Every Year

- Inspect the units casing for corrosion. If damage is found, clean and paint the surface with a rust-resistant primer and vinyl chlorinated lacquer.
- Clean the fan wheel and fan shaft. Remove rust with an emery cloth and apply a coat of heavy duty rust inhibitor.
- Clean the coils. Using a fin comb straighten any bent fins.
- Inspect the condensate pan and drain line; remove sludge or foreign materials that might obstruct proper drainage. Remove obstructions.
- Check damper linkages, set screws and blade adjustment. Clean, but do not lubricate, the nylon damper rod bushings.
- Clean damper operators.
- Inspect the control and power box wiring for secure connections and insulation.
- Rotate the fan wheel and check for obstructions in the fan housing. The wheel should not rub on the fan housing. Adjust the wheel to center if necessary and tighten wheel setscrews to the proper torque (see *Table 1 on page 22*).
- Check condition of gasketing and insulation around unit, door and dampers. Repair or replace as necessary.
- Examine flex connections for cracks or leaks. Repair or replace damaged material.

TABLE 1 - MINIMUM HEX HEAD BOLT TORQUE IN LB-FT - GRADE 5 BOLT

| SIZE (INCHES*) | THREAD DESIGNATION | MIN. TORQUE |
|----------------|--------------------|-------------|
| ¼-20 | UNC | 6 |
| 5/16-18 | UNC | 14 |
| 5/16-24 | UNF | 16 |
| 3/8-16 | UNC | 24 |
| 3/8-24 | UNF | 28 |
| 7/16-14 | UNC | 42 |
| 7/16-20 | UNF | 45 |
| ½-13 | UNC | 69 |
| ½-20 | UNF | 83 |
| 9/16-12 | UNC | 99 |
| 9/16-18 | UNF | 118 |
| 5/8-11 | UNC | 150 |
| 5/8-18 | UNF | 176 |
| ¾-10 | UNC | 254 |
| ¾-16 | UNF | 301 |
| 7/8-9 | UNC | 358 |
| 7/8-14 | UNF | 422 |
| 1-8 | UNC | 500 |
| 1-14 | UNF | 602 |

Drain Pan

Inspecting and Cleaning Drain Pans

If evidence of standing water or condensate overflow exists, identify and remedy the cause immediately. (Refer to the troubleshooting section for possible causes and solutions.) If microbial growth (mold) in the drain pan is observed, clean the pan immediately using the following procedure:

1. Disconnect all electrical power to the unit, tag and lock out power source.
2. Put on appropriate personal protective equipment.
3. Remove all standing water.
4. Use a scraper or other tools to remove any solid-matter. Remove solid matter with a vacuum device that uses high efficiency particulate arrestance (HEPA) filters with a minimum efficiency of 99.97% at 0.3-micron particle size.
5. Thoroughly clean the contaminated area with mild bleach and water solution or an EPA-approved sanitizer specifically designed for HVAC use. Carefully follow the sanitizer manufacturer

instructions regarding the use and the disposal of their product.

6. Immediately rinse the drain pan thoroughly with fresh water to prevent potential corrosion from the cleaning solution of the drain pan and drain line components.
7. Allow the unit to dry thoroughly before putting the system back into service.
8. Determine and correct the cause of the microbial contamination.
9. Be careful that the contaminated material does not contact other areas of the unit or building.

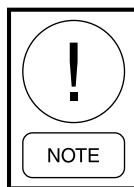

Properly dispose of all contaminated materials and cleaning solutions.

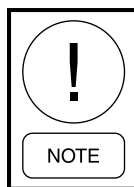

Standing water in drain pans can promote microbial growth (mold) that may cause unpleasant odors and serious health-related indoor air quality problems. If mold is found, it must be removed immediately and that portion of the unit properly cleaned and sanitized.

Air Filters

Catalog data tables provide filter size, type and quantity.

Throwaway Filters

To replace throwaway filters, install new filters with the directional arrows pointing in direction of airflow.

Fans

Inspecting and Cleaning Fans

Fan sections or air handlers should be inspected every six months at a minimum or more frequently if operating experience dictates. Accumulated dirt and organic matter on the interior surfaces of fans should be cleaned immediately. The suggested procedure for cleaning these surfaces is:

1. Disconnect all electrical power to the unit, tag and lock out power source.
2. Put on appropriate personal protective equipment.

3. Use a portable vacuum with HEPA filtration to remove the loose dirt and organic matter. The filter should be 99.97% efficient at .3 micron particle size.
4. If no microbial growth (mold) exists, thoroughly clean the fan and associated components with an industrial cleaning solution. Carefully follow the cleaning solution manufacturer instructions regarding use and disposal of their product.
5. If microbial growth (mold) is present remove the contamination, and thoroughly clean the affected area with an EPA-approved sanitizer specifically designed for HVAC use. Carefully follow the sanitizer manufacturer instructions regarding the use and disposal of their product.
6. Rinse the affected surfaces thoroughly with fresh water and a fresh sponge to prevent potential corrosion of metal surfaces.
7. Allow the unit to dry completely before putting it back into service.
8. Use caution to assure that any contaminated material does not contact other areas of the unit or building.

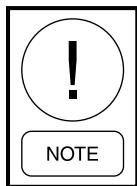

Properly dispose of all contaminated materials and cleaning solutions.

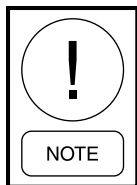

Important: If the microbial growth (mold) was found, the cause of the contamination must be determined and action taken to assure it does not reoccur.

Fan Bearings

Bearing Set Screw Alignment

Align bearing setscrews. See *Table 1 on page 22* for bearing setscrew torque.

Fan Bearings should be lubricated with a lithium base grease which conforms to NLGI Number 2 for consistency. See *Table 2 on page 23*, *Table 3 on page 23*, and *Table 4 on page 23* for recommended greasing intervals, operating range, and bearing grease capacities.

TABLE 2 - RECOMMENDED GREASING INTERVALS OF FAN BEARINGS

| OPERATING CONDITIONS | -20°F TO +140°F | 140°F TO 200°F |
|------------------------|-----------------|----------------|
| Clean, Dry | 3-6 months | 1-3 weeks |
| Dirty, Dry | 1-3 months | 1-4 weeks |
| Dirty, Wet, High Humid | 1-4 weeks | 1-14 days |

TABLE 3 - RECOMMENDED GREASES FOR VARIOUS OPERATING RANGES

| RECOMMENDED GREASES | RECOMMENDED OPERATING RANGE |
|---------------------|-----------------------------|
| Texaco-Multi Fak #2 | -20°F to +250°F |
| Shell Alvania #2 | -20°F to +250°F |
| Mobil Mobilux #2 | -20°F to +250°F |
| Exxon Unirex #2 | -20°F to +250°F |
| Exxon Beacon | -65°F to +250°F |

TABLE 4 - FAN BEARING MAXIMUM GREASE CAPACITY

| SHAFT SIZE IN INCHES | CAPACITY IN FL. OZ. |
|----------------------|---------------------|
| 1/2 – 3/4 | 1/8 |
| 7/8 – 1-3/16 | 3/8 |
| 1-1/4 – 1-1/2 | 5/8 |
| 1-11/16 – 1-15/16 | 7/8 |
| 2 – 2-7/16 | 1-1/4 |
| 2-1/2 – 2-15/16 | 2 |

Lubricating the Fan Bearing

To lubricate the fan bearing, complete the following:

1. Disconnect all electrical power to the unit, tag and lock out power source.
2. Check grease lines for tight connections at the grease fitting.
3. Using a manual low-pressure grease gun, add grease until a light bead appears at the bearing grease seal. Turn the fan wheel manually while adding grease.

Motor

General Inspection

Inspect the motor at regular intervals, approximately every 500 hours of operation or every three months, whichever occurs first. Operating conditions will vary the frequency of inspection and lubrication. Table 5 (*Table 5 on page 25*) lists recommended motor

greasing intervals. Keep the motor clean and the ventilation opening clear. The following steps should be performed at each inspection:

1. Check that the motor is clean. Check that the interior and exterior of the motor is free of dirt, oil, grease, water, etc. This can accumulate and block motor ventilation. If the motor is not properly ventilated over heating can occur and can cause early motor failure.
2. Use “Megger” periodically to ensure that the integrity of the winding insulation has been maintained. Record the “Megger” readings. Immediately investigate any significant drop in insulation resistance.
3. Check all electrical connectors to be sure that they are tight.
4. Check that all mechanical fasteners are properly tightened.

Lubrication and Bearings

Bearing grease will lose its lubrication ability over time, not suddenly. The lubricating ability of a grease (over time) depends primarily on the type of grease, the size of the bearing, the speed at which the bearing operates and the severity of the operating conditions. Good results can be obtained if the following recommendations are used in your maintenance program.

The recommended lubrication interval for 1800-RPM motor, up to and including NEMA frame 215T is every 12000 hours of operation. It is important to remember that this recommendation is base of average use. Refer to *Table 2 on page 23* for additional information.

Types of Grease

A high-grade ball or roller bearing grease should be used. See *Table 3 on page 23* for Recommended Greases.

Chevron SRI (Factory Installed) - Polyurea Base

Lubrication Procedure

Be sure that the grease you are adding to the motor is compatible with the grease already in the motor. Consult your factory representative if a grease other than the recommended type is to be used.

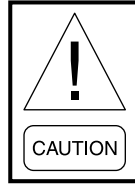

To avoid damage to motor bearings, grease must be kept free of dirt.

With Grease Outlet Plug

1. Clean grease fitting.
2. Remove grease outlet plug.
3. If motor is stopped, add the recommended amount of grease. If motor is to be greased while running, a slightly greater quantity of grease will have to be added. Add grease slowly until new grease appears at shaft whole in the end plate or purge outlet plug.
4. Re-install grease outlet plug.

Without Grease Outlet Plug

1. Disassembly motor.
2. Add recommended amount of grease to bearing and bearing cavity. (Bearing should be about 1/3 full of grease and outboard bearing cavity should be about 1/2 full of grease.)
3. Assemble motor.

To re-lubricate the motor, consult the maintenance tag provided on the motor.

Refer to *Table 1 on page 22* for minimum torque of motor mounting and bearing bolts.

TABLE 5 - RECOMMENDED MOTOR GREASING SCHEDULE

| AVERAGE DAILY OPERATING HOURS | AMBIENT TEMP. MAXIMUM | AVERAGE ENVIRONMENT | .25 TO 7.5 HP MOTORS | 10 HP MOTORS |
|-------------------------------|-----------------------------|--|----------------------|----------------|
| 8-16 | 40°C | Clean and Dry | Every 5 years | Every 3 years |
| 12-24 | 50°C | Moderate Dirt or Moisture | Every 2 years | Every year |
| Any | >50°C or Class H Insulation | Severe (very dirty or high temperatures) | Every 6 months | Every 3 months |

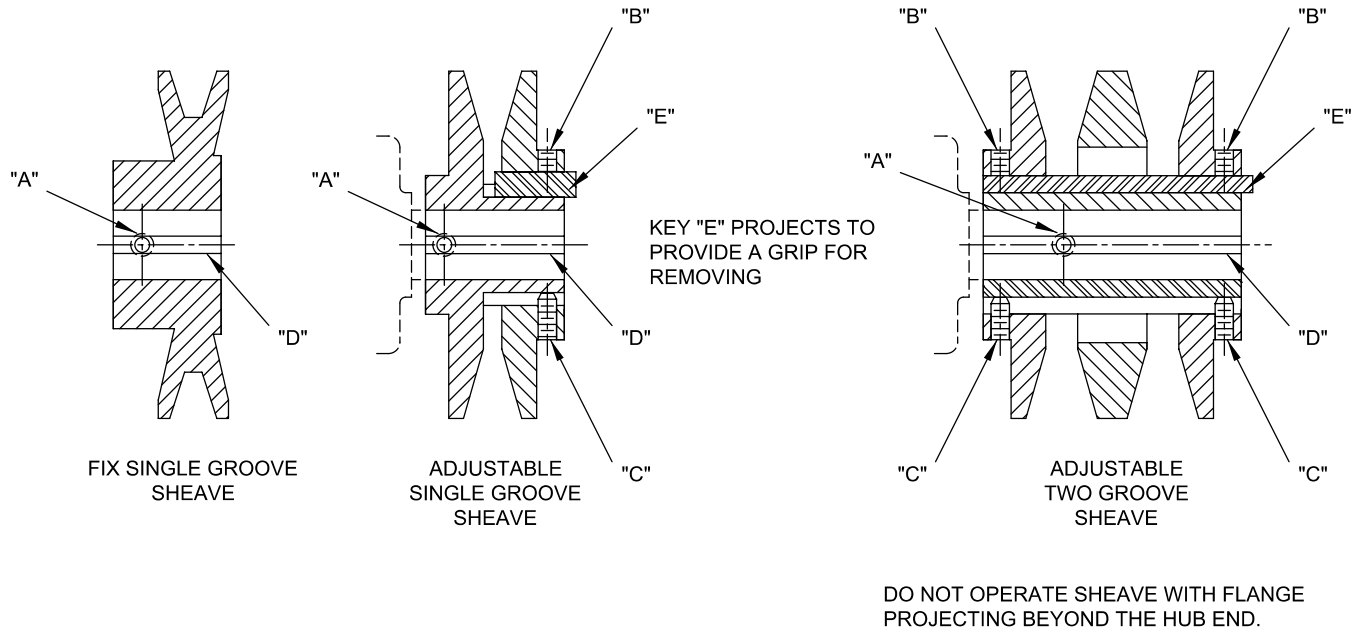

FIGURE 11 - MOUNTING SHEAVES

Drives

Mounting Straight Bore Sheaves

1. Make sure there are no nicks or burrs on key, key-way and shaft. If so, remove by proper methods.
2. Check key size with both the shaft and the sheave.
3. All straight bore sheaves should be mounted on the motor or driver shaft with setscrew (A) toward the motor (see Figure 11 on page 25). The sheave should be close to the motor as possible with setscrew (A) in full contact with the key.



If the setscrew (a) is not fully in contact with key, the sheave assembly could come off.

4. Be sure that both the driver and driven sheaves are in alignment and that the shafts are parallel. The centerline of the driver sheave must line up with the centerline of the driven sheave. Angle "A" cannot exceed 1/2° (see Figure 12 on page 26).
5. Insert key (D) between the sheave and the shaft and tighten setscrew (A) in place using torque value from Table 1 on page 22.
6. Put on belts and adjust belt tension properly. Refer to Belts on page 27 for tensioning instructions.
7. Be sure that all keys are in place. Make sure all setscrews and capscrews are torqued properly before starting drive. Check setscrew and belt tension after 24 hours of service.

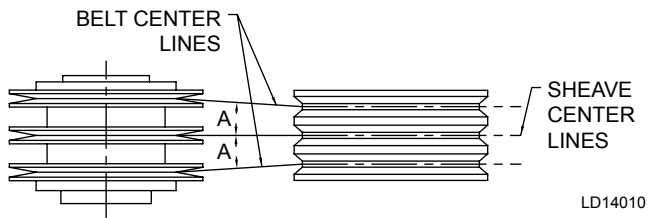
**FIGURE 12 - SHEAVE ALIGNMENT****Mounting Split Tapper Sheaves**

1. Make sure there are no nicks or burrs on the key, keyway, and shaft. If so, remove by proper methods.
2. Remove any oils, lubricants or contaminants from the bushing, capscrew, and tapered bore.
3. Check key size with both the bushing and the shaft.
4. Put bushing (B) loosely in hub of sheave (A). Do not press tight onto drive. Start capscrew (C) by hand, turning them just enough to engage the threads in the tapered holes on hub. Do not use wrench at this time. The bushing should be loose enough in the hub to move slightly.
5. Slide assembly on to shaft making allowance for endplay of shaft to prevent rubbing. Do not force assembly on shaft. If it does not go on easily, check shaft, bushing, and key size.
6. Be sure that both the driver and driven sheaves are in alignment and that the shafts are parallel. The centerline of the driver sheave must line up with the centerline of the driven sheave. Angle "A" cannot exceed $1/2^\circ$ (see *Figure 12 on page 26*).
7. Insert key (D) between the sheave and the shaft.
8. Tighten capscrews progressively with wrench. Do this following a star pattern, taking a partial turn on each capscrew successively until all are tight (see *Table 1 on page 22* for proper torque).

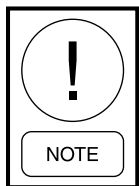

Do not attempt to pull flange flush with hub - some gap should remain between flange and hub after tightening.

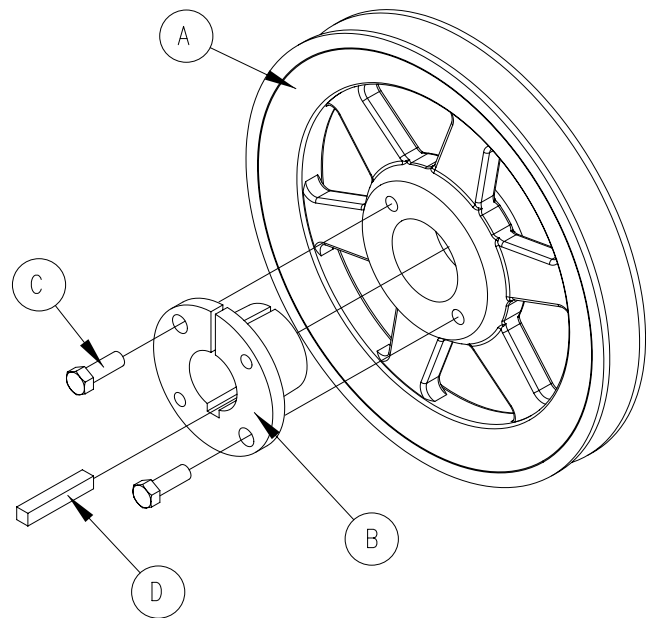
**FIGURE 13 - SPLIT TAPPER SHEAVE MOUNTING**

9. Put on belt and adjust belt tension properly. Refer to *Belt Section for tensioning instructions*.
10. Be sure that all keys are in place. Be sure that all setscrews and capscrews are torqued properly before starting drive. Check setscrews and belt tension after 24 hours of service.

Adjust Variable Pitched Sheaves

(Provided on motor only). See *Figure 11 on page 25*.

1. Slack off all belt tension by moving motor towards blower shaft until belts are free of groove(s). For easiest adjustment, remove belts from groove(s).
2. Loosen setscrew (B) in outer locking ring.
3. Loosen but do not remove capscrew.
4. Remove key (D).

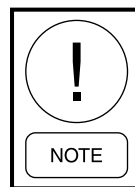

This key projects a small amount to provide a grip for removal.

5. Adjust pitch diameter by opening or closing the movable flange(s) by a half or full turn. Opening the flange(s) will decrease the blower speed, closing the flange(s) will increase blower speed.

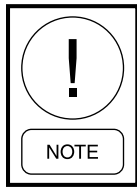

Two groove sheaves are supplied with both grooves set at the same pitch diameter. Both movable flanges must be rotated the same number or turns to ensure the same pitch diameter for satisfactory operation.



Do not open sheaves more than five turns for "a" belt or 6 turns for "b" belt. Doing so may cause the belts to sit improperly, and cause the flanges to detach in service.

6. Replace key (D).
7. Tighten setscrew (B) in outer locking ring and capscrew (C) with torque wrench to the values in Table 1 on page 22 .
8. Put on belts and adjust belt tension properly. Refer to Belt Section for tensioning instructions.
9. Be sure that all keys are in place. Be sure that all setscrews and capscrews are torqued properly before starting drive. Check setscrews and belt tension after 24 hours of service.

Belts

Adjusting Belt Tension.

See Figure 14 on page 27

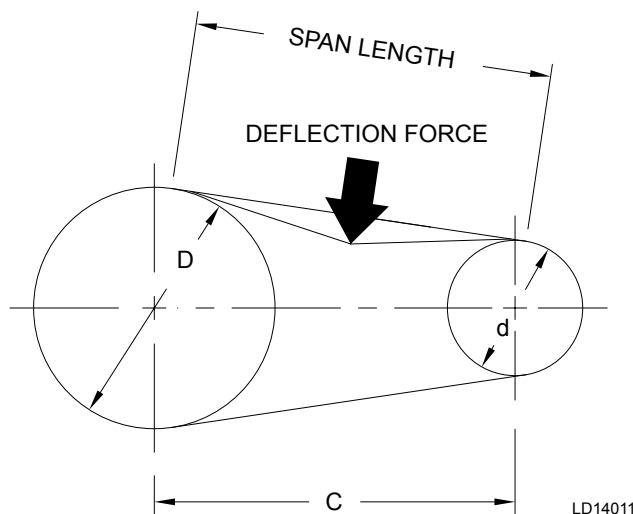

FIGURE 14 - BELT TENSION

1. Measuring belt span. Lay a tape measure along the top of the belt, measure between the points at which the outside of the belt meets the outside of the sheaves. The following formula can be used to calculate the belt span.

$$Span = \sqrt{C^2 - \left(\frac{D-d}{2}\right)^2}$$

C = Center distance shaft to shaft

D = Driver sheave (large sheave) pitch diameter

d = Driver sheave (small sheave) pitch diameter

LD14003

2. Calculate deflection (Deflection = Span ÷ 64)
3. See Table 6 on page 28 for correct deflection force.
4. Using a spring scale, apply force at right angle to the midpoint of the belt span (see Figure 14 on page 27).
5. Check the tension at least twice during the first day of operation, and periodically thereafter.

How to Increase Belt Life

- Keep sheaves and belts clean. Abrasive dust, rust, oils, and acids reduce service life.
- Give drives clearance. Never let belts run against belt guards or other obstructions.
- Never force belts. Move motor on adjustment base so belts go on easily.
- Eliminate slack. Adjust motor and tighten belts in position. Slack belts wear excessively which cause slippage and deliver less air.
- Use matched belts. Matched belts run smoother and last longer because the load is evenly distributed. Never partially replace a set of belts.
- Mount belts straight. Shaft must be parallel and sheave grooves in alignment to prevent unnecessary belt wear.
- Do not overload belt. Belts have a specific HP rating that must not be exceeded.

Coils

The frequency of required cleaning is dependent on the operating hours of the system, filter maintenance and efficiency as well as dirt load.

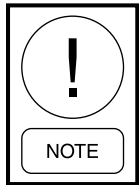

Coils may become externally fouled as result of normal operation. Dirt on the surface of the coil reduces its ability to transfer heat that can result in reduced performance, and increased operating energy costs. If the dirt on the surface of the coil becomes wet, which commonly occurs with cooling coils, microbial growth (mold) can result, in turn causing unpleasant odors and serious health related indoor air quality problems.



Fin edges are sharp. Fins are fragile; care must be exercised to avoid damaging fins.

Steam, Hot Water and Chilled Water Coils

Steam, hot water, and chilled water coils should be kept clean to maintain maximum performance. If fins become dirty, clean with steam and detergent, hot water spray and detergent, or one of the commercially available chemical coil cleaners. Rinse coils thoroughly after cleaning.

1. Disconnect all electrical power to the unit, tag and lock out power source.
2. Put on appropriate personal protective equipment.

3. Gain access to the coil section of the unit.
4. Use a soft brush to remove loose debris from sides of the coil.
5. Use a steam-cleaning machine, starting from the top of the coil and working downward. Clean the leaving airside of the coil first, then the entering airside. Use a block-off to prevent steam from blowing through the coil and into dry sections of the unit.
6. Repeat step 5 as necessary.
7. Confirm that the drain line is open following the cleaning.
8. Allow the unit to dry thoroughly before putting the system back in service.
9. Straighten any coil fins that may have been damaged during the cleaning process with a fin comb.
10. Replace all panels and parts and restore electrical power to the unit.
11. Use caution to assure that any contaminated material does not contact other areas of the unit or building.

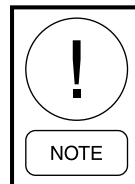

Properly dispose of all contaminated materials and cleaning solutions.

TABLE 6 - DETERMINING DEFLECTION FORCE

| BELT CROSS SECTION | SMALLEST SHEAVE DIAMETER RANGE | RPM RANGE | BELT DEFLECTION FORCE | |
|--------------------|--------------------------------|-------------|-----------------------|----------|
| | | | USED BELT | NEW BELT |
| A | 3.0 - 3.6 | 400 - 2500 | 3.7 | 5.5 |
| | | 2501 - 4000 | 2.8 | 4.2 |
| | 3.8 - 4.8 | 400 - 2500 | 4.5 | 6.8 |
| | | 2501 - 4000 | 3.8 | 5.7 |
| | 5.0 - 7.0 | 400 - 2500 | 5.4 | 8.0 |
| | | 2501 - 4000 | 4.7 | 7.0 |
| B | 4.4 - 5.6 | 860 - 2500 | 5.3 | 7.9 |
| | | 2501 - 4000 | 4.5 | 6.7 |
| | 5.8 - 8.6 | 860 - 2500 | 6.3 | 9.4 |
| | | 2501 - 4000 | 6.0 | 8.9 |

Refrigerant Coils

Refrigerant coils should be kept clean to maintain maximum performance. If fins become dirty, clean with cold water and detergent, or one of the commercially available chemical coil cleaners. Rinse coils thoroughly after cleaning.

1. Follow steps 1-4 from Steam and Water Coil cleaning procedure preceding.
2. Mix a high quality coil cleaning detergent with water accordance to the manufacturer's instructions. If the detergent is strongly alkaline after mixing (pH 8.5 or higher), it must contain an inhibitor. Carefully follow the detergent manufacturer's instructions on the use of the product.
3. Place the mixed solution in a garden sprayer or high-pressure sprayer. If a high pressure sprayer is used note the following:
 - Maintain a minimum nozzle spray angle of 15 degrees.
 - Spray perpendicular to the coil face.
 - Protect other areas of the air handler and internal controls from contact with moisture or the cleaning solution.
 - Keep the nozzle at least 6 inches from the coil.
 - Do not exceed 600 psi.
4. Spray the leaving airside of the coil first, then the entering airside. Use a block-off to prevent spray from going through the coil and into dry sections of the unit and/or system ductwork. Carefully follow the cleaning solution manufacturer's usage instructions.
5. Thoroughly rinse both sides of the coil and the drain pan with cool, clean water.
6. Repeat steps 4 and 5 as necessary.
7. Straighten any coil fins that may have been damaged during the cleaning process with a fin comb.
8. Confirm that the drain line remains open following the cleaning process.
9. Replace all panels and parts and restore electrical power to the unit.

10. Use caution to assure that any contaminated material does not contact other areas of the unit or building.

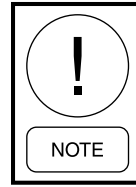

Properly dispose of all contaminated materials and cleaning solutions.

Winterizing Water Coils

Due to air stratification, failure of outdoor air dampers and/or preheat controls, coil freeze-up can occur. Scheduled draining of water cooling coils for winter shutdown cannot be depended upon as insurance against interior tube freezeup. Freeze-up will result in severe coil damage. It is recommended that all coils be drained as thoroughly as possible and then treated in the following manner.

Fill each coil independently with an anti-freeze solution using a small circulating pump and again thoroughly drain. Check freezing point of anti-freeze before proceeding to next coil. Due to a small amount of water always remaining in each coil, there will be a diluting effect. The small amount of anti-freeze solution remaining in coil must always be sufficient enough to prevent freeze-up.



Carefully read instructions for mixing anti-freeze solution used. Some products will have a higher freezing point in its natural state than when mixed with water. The freezing of coils is not the responsibility of Johnson Controls.

OPERATING GUIDELINES

Operating Limits

Do not exceed the operating limits in *Table 7 on page 30*. A fan wheel that is operated beyond the rpm and temperature limits shown may suffer permanent distortion or failure.

Vibration Levels

Each unit that is shipped has been trim-balanced to function properly. Although the factory requirements are much tighter, to assure satisfactory operation after enduring the rigors of shipping and installation. The following is accepted industry guidelines for field-balancing fans found in *Table 8 on page 30*.

Vibration Causes

1. Wheel imbalance.
 - a. Dirt or debris on wheel blades.
 - b. Loose setscrews in wheel hub or bearing-to-shaft.
 - c. Wheel distorted from over-speed.
 - d. Wheel balance weight missing.
2. Bent blower shaft.
3. Drive faulty.
 - a. Variable pitch sheaves - Axial and radial run-out of flanges; uneven groove spacing; out of balance. Also similar fault in driven sheave.
 - b. Bad V-belts; lumpy, or mismatched belts.
 - c. Belt tension too tight or loose.
4. Bad bearings, loose bearing hold-down bolts.
5. Motor imbalance.
6. Fan section not supported evenly on foundation.
7. Fan shaft not parallel with motor shaft.

Periodic Service and Maintenance

1. Check all moving parts for wear every six months.
2. Check bearing collar, sheave, and wheel hub setscrews, sheave capscrews, and bearing hold-down bolts for tightness every six months.

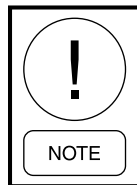
APPLICATION RECOMMENDATION FOR COILS

Observe all local codes and industry standards

General

Piping design, sizing, and installation information presented in the ASHRAE Handbooks should be followed in the design and installation of piping.

Water Cooling Coils

1. Water supply, water return, drain and vent connections are labeled on the end panel.
2. Water supply and water return connections are checked.
3. Avoid undue stress to the connection extending through unit panel. Use backup pipe wrench to avoid breaking the weld between coils connection and header.
4. Follow recommendations of the control manufacturer regarding types, sizing and installation of control valves.

Direct Expansion Coils

1. The coil suction connection extended through the end panel of the coil section. The coil distributor is located inside the cabinet on the same side as the suction connection.

TABLE 7 - FORWARD CURVE FAN DATA

| DIAMETER | 9 X 4 | 9 X 6 | 10 X 7 | 12 X 9 | 12 X 12 | 15 X 11 | 18 X 13 | 18 X 18 |
|----------------------|-------|-------|--------|--------|---------|---------|---------|---------|
| Maximum RPM Class I | 2200 | 2200 | 2000 | 1800 | 1700 | 1600 | 1200 | 1200 |
| Maximum RPM Class II | N/A | N/A | N/A | N/A | N/A | 1700 | 1475 | 1450 |

Note: Maximum air temperature through fan section is 225°F (107°C)

TABLE 8 - VIBRATION LEVELS

| FAN SPEED (RPM) | VIBRATION |
|-----------------|------------------------------|
| 800 or less | 5 mils maximum displacement |
| 801 or greater | .20 in/sec. Maximum velocity |

Note: Excessive vibration from any cause contributes to premature fan and motor bearing failure. Overall, vibration levels should be monitored every six months of operation. An increase in levels is an indication of potential trouble.

2. DX coils are shipped capped and sealed with a 20 PSIG holding charge of dry nitrogen. Remove nitrogen charge from coil by depressing Schraeder stem, prior to cap removal.
3. Heat the soft solder and remove the Schraeder valve and flare.
4. Attach thermal expansion valve to distributor.
5. Do not apply heat to the body or thermal element of the expansion valve. Wrap in wet rag while brazing.
6. The thermostatic expansion valve must be of the external equalizer tube type. Connect the ¼-inch diameter external equalizer tube provided on the coil to connection on expansion valve.
7. Care should be exercised when piping up the system to be sure all joints are tight and all lines are dry and free of foreign material.

Steam Coils

(maximum steam pressure is 15 PSIG)

1. Steam supply and steam return connections are male N.P.T. copper pipe and are labeled on the end panel of coil section. Connections extend through coil section end panel.
2. When installing couplings, do not apply undue stress to the connection extending through unit panel. Use backup pipe wrench to avoid breaking the weld between coil connection and header.
3. Support piping independently of coils and provide adequate piping flexibility. Stresses resulting from expansion of closely coupled piping can cause serious damage.
4. Do not reduce pipe size at the coil return connection. Carry return connection size through the dirt pocket, making the reduction at the branch leading to trap.
5. It is recommended that vacuum breakers be installed on all applications to prevent retaining condensate in the coil. Generally, the vacuum breaker is to be connected between the coil inlet and the return main, the vacuum breaker should be open to the atmosphere and the trap design should allow venting of large quantities of air.
6. Do not drip supply mains through the coil.

7. Do not attempt to lift condensate when using modulating or on/off control.
8. Size traps in accordance with manufacturers' recommendations. Be certain that the required pressure differential will always be available.

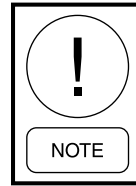

Do not undersize.

9. Float and thermostatic or bucket traps are recommended for low-pressure steam. Thermostatic traps should be used only for air venting.
10. Locate traps at least 12 inches below the coil return connection.
11. Multiple coil installation.
 - a. Each coil or group of coils that is individually controlled must be individually trapped.
 - b. Coils in series: Separate traps are required for each coil, or bank of coils, in series.
 - c. Coils in parallel: A single trap may generally be used but an individual trap for each coil is preferred.
 - d. Do not attempt to lift condensate when using modulating or on/off control.
12. With coils arranged for series airflow, a separate control is required on each bank or coil in the direction of airflow.
13. Modulating valves must be sized properly.

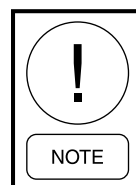

Do not undersize.

14. Freezing conditions (entering air temperature below 35°F)
 - a. 5-psi steam must be supplied to coils at all times.
 - b. Modulating valves are not recommended.
 - c. Consideration should be given to the use of two or three coils in series with two position steam control valves on that coil or coils

which will be handling 35°F, or colder, air. The desired degree of control can be obtained with a modulating valve on the downstream coil.

- d. Provision should always be made to thoroughly mix fresh air and return air before it enters the coil. In addition, temperature control elements must be properly located to obtain true air mixture temperatures.
- e. As additional protection against freeze-up, the trap should be installed sufficiently below coil to provide an adequate hydrostatic head to ensure removal of condensate during an interruption in the steam pressure. Estimate 3 feet for each 1-psi of trap differential required.
- f. On startup, admit steam to coil ten minutes before admitting outdoor air.
- g. Provision must be made to close fresh air dampers if steam supply pressure falls below minimum specified.

Water Heating Coils

1. Water supply and water return connections extend through the end panel of the coil section. All connections are labeled on the end panel.
2. Water supply and water return connections are male N.P.T copper pipe.
3. When installing couplings, do not apply undue stress to the connection extending through unit panel. Use a backup pipe wrench to avoid breaking the weld between coil connection and header.
4. Follow recommendations of the control manufacturer regarding types, sizes and installation of control valves.
5. Hot water coils are not recommended for use with entering air below 40°F.
6. If fresh air and return air are to be heated by a hot water coil, care should be used in the design of the system to assure thorough mixing before air enters the coil.

SECTION 5 - TROUBLESHOOTING

Use Table 9 to assist in identifying the cause (s) of malfunction in the AMI.

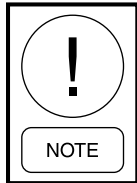

This table is intended as a diagnostic aid only. For detailed repair procedures, contact your Johnson Controls representative.

TABLE 9 - AMI TROUBLESHOOTING ANALYSIS

| SYMPTOM | PROBABLE CAUSE | RECOMMENDED ACTION |
|--|--|--|
| BEARING IS EXCESSIVELY HOT | First start after relubrication (grease distribution). | Allow machine to cool down and restart. |
| | Over-lubrication. | Clean surfaces of grease and purge. |
| | Over tensioned belts. | Adjust belt tension. |
| | No lubrication. | Apply lubricant. Check bearing for damage. |
| | Misaligned bearing. | Correct alignment. Check shaft level. |
| MOTOR FAILS TO START | Blown fuse or open circuit breaker. | Replace fuse or reset circuit breaker. |
| | Overload trip. | Check and reset overload. |
| | Improper wiring connections. | Check wiring with diagram supplied on unit. |
| | Improper current supply. | Compare actual supply power with motor nameplate recommendations. Contact power company for adjustments. |
| MOTOR STALLS | Mechanical failure. | Check that motor and drive rotate freely. Check bearing lubricant. |
| | Open phase. | Check line for an open phase. |
| | Overloaded motor. | Reduce load or replace with larger motor. |
| EXCESSIVE VIBRATION | Low line voltage. | Check voltage across AC line. Correct voltage if possible. |
| | Poor alignment. | Align bearing setscrews (see Fig. 8). Loosen and retighten bearing setscrew. |
| | Shipping spacers not removed. | Remove shipping spacers and/or bolts. |
| | Over tensioned belts. | Adjust belt tension. |
| MOTOR RUNS AND THEN DIES DOWN | Misaligned drive. | Align drive. |
| | Partial loss of line voltage. | Check for loose connections. Determine adequacy of main power supply. |
| MOTOR DOES NOT COME UP TO SPEED | Stator shorts when motor warms up. | Replace motor. |
| | Low voltage at motor terminals. | Check voltage across AC line and correct voltage loss if possible. |
| MOTOR OVERHEATS | Line wiring to motor too small. | Replace with larger sized wiring. |
| | Overloaded motor. | Reduce load or replace with a larger motor. |
| | Motor fan is clogged with dirt. | Remove fan cover, clean fan and replace preventing proper ventilation cover. |
| | Temperature leaving heating section is too high. | Increase airflow volume, reduce hot water inlet temperature, turn thermostat down. |

TABLE 9 - AMI TROUBLESHOOTING ANALYSIS (CONT'D)

| SYMPTOM | PROBABLE CAUSE | RECOMMENDED ACTION |
|--|---|--|
| EXCESSIVE MOTOR NOISE | Motor mounting bolts loose. | Tighten motor mounting bolts. |
| | Rigid coupling connections. | Replace with flexible connections. |
| | Worn motor bearings. | Replace bearings and seals. |
| | Fan rubbing on fan cover. | Remove interference in motor fan housing. |
| RAPID MOTOR BEARING WEAR | Excessive overhung load due to over-tensioned drive. | Check belt tension and overhung load. |
| | Excessive overhung load due to a small diameter motor sheave. | Replace sheave with larger one. |
| LOOSE FAN BELT | Motor is poorly positioned. | Adjust belt tension. |
| | Worn or damaged belts. | Replace belt or belt set. Check sheave alignment. |
| | Worn sheaves. | Replace sheaves. |
| SHORT BELT LIFE | Worn sheaves. | Replace sheaves. |
| | Misaligned belt. | Realign drive with MVP sheave set at mean pitch diameter. |
| | Grease or oil on belts. | Check for leaky bearings. Clean belts and sheaves. |
| | Belt slipping. | Adjust tension. |
| | Belts rubbing. | Remove obstruction or realign drive for clearance |
| BEARING NOISE | Poor alignment. | Loosen bearing setscrews and realign (<i>see Fig. 10</i>). |
| | Inadequate lubrication. | Grease bearing(s). |
| LOW COIL CAPACITY (CHILLED WATER) | Air is bypassing coil. | Prevent bypass with block-offs. |
| | Coil tubes are blocked. | Clean and unblock tubes. |
| | Incorrect airflow. | Check fan operating conditions. |
| | Incorrect gpm. | Check water pumps, valves and lines for obstructions. |
| | Incorrect water temperature. | Provide proper water temperature. |
| LOW COIL CAPACITY (REFRIGERANT) | Air is bypassing coil. | Prevent bypass with block-offs. |
| | Coil tubes are blocked. | Clean and unblock tubes. |
| | Incorrect airflow. | Check fan operating conditions. |
| | Expansion valve not operating. | Check sensing bulb location and TXVN operation. |
| | Poor refrigerant distribution. | Check for blockage in distributor and tubes. |
| DRAIN PAN IS OVERFLOWING | Plugged drain line. | Clean drain line. |
| | Unit not level. | Level unit. |
| STANDING WATER IN DRAIN PAN | Improper trap design. | Design trap for unit. |
| EXCESS DIRT IN UNIT | Missing filters. | Replace filters. |
| | Filter bypass. | Reduce filter bypass. |
| MOLD INSIDE AIR HANDLER | Standing water in drain pan. | See "Standing water" symptoms. |

The following factors can be used to convert from English to the most common SI Metric values.

TABLE 10 - SI METRIC CONVERSION

| MEASUREMENT | MULTIPLY ENGLISH UNIT | BY FACTOR | TO OBTAIN METRIC UNIT |
|---------------|-------------------------------|-----------|-----------------------|
| Capacity | Tons Refrigerant Effect (ton) | 3.516 | Kilowatts (kW) |
| Power | Horsepower | 0.7457 | Kilowatts (kW) |
| Flow Rate | Gallons / Minute (gpm) | 0.0631 | Liters / Second (l/s) |
| Length | Feet (ft) | 0.3048 | Meters (m) |
| | Inches (in) | 25.4 | Millimeters (mm) |
| Weight | Pounds (lbs) | 0.4538 | Kilograms (kg) |
| Velocity | Feet / Second (fps) | 0.3048 | Meters / Second (m/s) |
| Pressure Drop | Feet of Water (ft) | 2.989 | Kilopascals (kPa) |
| | Pounds / Square Inch (psi) | 6.895 | Kilopascals (kPa) |

5

TEMPERATURE

To convert degrees Fahrenheit (°F) to degrees Celsius (°C), subtract 32° and multiply by 5/9 or 0.5556.

Example: $(45.0^{\circ}\text{F} - 32^{\circ}) \times 0.5556 = 27.2^{\circ}\text{C}$

To convert a temperature range (i.e., a range of 10°F) from Fahrenheit to Celsius, multiply by 5/9 or 0.5556.

Example: $10.0^{\circ}\text{F range} \times 0.5556 = 5.6^{\circ}\text{C range}$



P.O. Box 1592, York, Pennsylvania USA 17405-1592
Copyright © by Johnson Controls 2013
Form 102.19-NOM1 (813)
Issue Date: August 26, 2013
Supersedes: 102.19-NOM1 (1012)

800-861-1001
www.johnsoncontrols.com

Subject to change without notice. Printed in USA
ALL RIGHTS RESERVED