



# SC-EQ COMMUNICATION CARD

(Also Contains Relevant SC-AP Information)

INSTALLATION INSTRUCTIONS

Supersedes: 450.50-N1 (816)

Form 450.50-N1 (217)

035-25087-000



YVWA



YK



Issue Date:  
February 10, 2017  
REV. 5



# IMPORTANT!

## READ BEFORE PROCEEDING!

### GENERAL SAFETY GUIDELINES

This equipment is a relatively complicated apparatus. During rigging, installation, operation, maintenance, or service, individuals may be exposed to certain components or conditions including, but not limited to: heavy objects, refrigerants, materials under pressure, rotating components, and both high and low voltage. Each of these items has the potential, if misused or handled improperly, to cause bodily injury or death. It is the obligation and responsibility of rigging, installation, and operating/service personnel to identify and recognize these inherent hazards, protect themselves, and proceed safely in completing their tasks. Failure to comply with any of these requirements could result in serious damage to the equipment and the property in

which it is situated, as well as severe personal injury or death to themselves and people at the site.

This document is intended for use by owner-authorized rigging, installation, and operating/service personnel. It is expected that these individuals possess independent training that will enable them to perform their assigned tasks properly and safely. It is essential that, prior to performing any task on this equipment, this individual shall have read and understood the on-product labels, this document and any referenced materials. This individual shall also be familiar with and comply with all applicable industry and governmental standards and regulations pertaining to the task in question.

---

## SAFETY SYMBOLS

The following symbols are used in this document to alert the reader to specific situations:



*Indicates a possible hazardous situation which will result in death or serious injury if proper care is not taken.*



*Identifies a hazard which could lead to damage to the machine, damage to other equipment and/or environmental pollution if proper care is not taken or instructions and are not followed.*



*Indicates a potentially hazardous situation which will result in possible injuries or damage to equipment if proper care is not taken.*

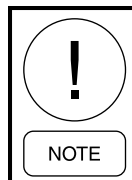

*Highlights additional information useful to the technician in completing the work being performed properly.*



*External wiring, unless specified as an optional connection in the manufacturer's product line, is not to be connected inside the control cabinet. Devices such as relays, switches, transducers and controls and any external wiring must not be installed inside the micro panel. All wiring must be in accordance with Johnson Controls' published specifications and must be performed only by a qualified electrician. Johnson Controls will NOT be responsible for damage/problems resulting from improper connections to the controls or application of improper control signals. Failure to follow this warning will void the manufacturer's warranty and cause serious damage to property or personal injury.*

## CHANGEABILITY OF THIS DOCUMENT

In complying with Johnson Controls' policy for continuous product improvement, the information contained in this document is subject to change without notice. Johnson Controls makes no commitment to update or provide current information automatically to the manual or product owner. Updated manuals, if applicable, can be obtained by contacting the nearest Johnson Controls Service office or accessing the Johnson Controls QuickLIT website at <http://cgproducts.johnsoncontrols.com>.

It is the responsibility of rigging, lifting, and operating/service personnel to verify the applicability of these documents to the equipment. If there is any question

regarding the applicability of these documents, rigging, lifting, and operating/service personnel should verify whether the equipment has been modified and if current literature is available from the owner of the equipment prior to performing any work on the chiller.

### CHANGE BARS

Revisions made to this document are indicated with a line along the left or right hand column in the area the revision was made. These revisions are to technical information and any other changes in spelling, grammar or formatting are not included.

---

## ASSOCIATED LITERATURE

MANUAL DESCRIPTION	FORM NUMBER
SC-AP Installation Instructions	LIT 24-10737-75
SC-AP Quick Start	LIT 24-10737-87

THIS PAGE INTENTIONALLY LEFT BLANK.

## TABLE OF CONTENTS

<b>SECTION 1 - INTRODUCTION</b> .....	<b>7</b>
Overview .....	7
Emissions Compliance .....	7
<b>SECTION 2 - INSTALLATION</b> .....	<b>9</b>
Wiring .....	9
Protection of Communication Ports .....	9
High Noise Environments .....	10
Electrical Noise Mitigation to Equipment .....	10
Electrical Noise Mitigation SC-EQ to BAS .....	10
Types of Communication Ports .....	10
Network Termination.....	10
Media Access Control (MAC) Address .....	11
BAS Network Wiring.....	12
Mounting .....	13
OptiView Panel Installation.....	13
Small Tonnage Panel Installation .....	15
Other Chiller Panel Installation.....	16
Mounting on a Micro Panel.....	16
Wall Mounting.....	17
Applying Power .....	17
Equipment Configuration.....	19
Setting the Rotary Switch on Chiller Panels .....	19
<b>SECTION 3 - TROUBLESHOOTING</b> .....	<b>27</b>
LED Indicators .....	27
Multimeter Checks of the BAS Port.....	28
Firmware Update .....	29
Repair Information .....	29
SC-AP OptiView Mounting .....	31
<b>SECTION 4 - SC-AP GATEWAY</b> .....	<b>31</b>
Using the SC-AP for Troubleshooting.....	33
E-Link Replacement .....	34
Manually Setting the Chiller Model.....	35
<b>SECTION 5 - TECHNICAL SPECIFICATIONS</b> .....	<b>37</b>
Instructions for the BAS Contractor .....	39

THIS PAGE INTENTIONALLY LEFT BLANK.

## SECTION 1 - INTRODUCTION

### OVERVIEW

The SC-EQUIP (SC-EQ) Communication Card supersedes the E-Link Gateway and provides BAS network connectivity for Johnson Controls® and YORK® mechanical equipment, such as chillers and rooftop units. It is designed with four active serial ports: The J12 BAS (RS-485) port, the J7 Equipment (RS-232) port, the J8 Equipment (RS-485) port and the J11 CS port which allows equipment data to be sent to the Johnson Controls Remote Operation Center for remote chiller monitoring and diagnostics.

To simplify the installation and setup, the SC-EQ Comm Card automatically determines the BAS protocol and Baud rate and the model of the connected chiller or rooftop unit. The only user setting is the MAC address for the SC-EQ on the BAS network.

Several SC-EQ Comm Card models are available for connection to various types of input voltage and equipment. For chillers using the OptiView™ 01730, 02430 or 03630 microboards, the SC-EQ Comm Card consists of a single circuit board attached to four studs inside the Micro Panel, using the accessory mounting kit. The microboard supplies 12 VDC input power, eliminating the need for an external power supply.

For screw compressor chillers using the 02478 or 03478 microboards, the SC-EQ Comm Card is installed inside the Micro Panel, using the accessory mounting kit. The microboard supplies 12 VDC input power, eliminating the need for an external power supply.

For scroll compressor chillers using the 02050 or 02550 microboards, the SC-EQ Comm Card is installed inside the Micro Panel and requires an additional transformer to supply power to the SC-EQ Comm Card. The transformer is included in the SC-EQ Scroll Chiller Installation Kit.

For other types of chillers, the SC-EQ Comm Card is packaged in its own enclosure. In addition to the SC-EQ circuit board, a transformer is included inside the enclosure that converts a 120VAC or 240VAC input to 24 VAC power.

**TABLE 1 - SC-EQ PRODUCT CODE NUMBERS**

DESCRIPTION	PRODUCT CODE NUMBERS
SC-EQ with Serial Outputs (BACnet Master-Slave/Token-Passing [MS/TP], Modbus Remote Terminal Unit [RTU], and N2)	SE-SCC1001-1 (031-03610-000)
SC-EQ with Serial Outputs in Enclosure	YK-SCCPNL-0
SC-EQ OptiView Panel Installation Kit	331-03607-000
SC-EQ Screw Chiller Panel Installation Kit	392-41228-000
SC-EQ Scroll Chiller Panel Installation Kit	392-41230-001

**NOTE:** For LON integration use the appropriate E-Link.

### EMISSIONS COMPLIANCE

#### United States

This equipment has been tested and found to comply with the limits for a Class A digital device pursuant to Part 15 of the FCC Rules. These limits are designed to provide reasonable protection against harmful interference when this equipment is operated in a commercial environment. This equipment generates, uses, and can radiate radio frequency energy and, if not installed and used in accordance with the instruction manual, may cause harmful interference to radio communications. Operation of this equipment in a residential area is likely to cause harmful interference, in which case the user will be required to correct the interference at his/her own expense.

#### Canada

This Class (A) digital apparatus meets all the requirements of the Canadian Interference-Causing Equipment Regulations.

Cet appareil numérique de la Classe (A) respecte toutes les exigences du Règlement sur le matériel brouilleur du Canada.

THIS PAGE INTENTIONALLY LEFT BLANK.

## SECTION 2 - INSTALLATION

The SC-EQ is supplied as a circuit board that can be installed directly into the equipment's enclosure, or can be supplied pre-mounted in an enclosure ready for line voltage. Accessory mounting kits are used to mount the SC-EQ Comm Card directly into OptiView, Latitude, and IPU-II based Micro Panels.

**IMPORTANT:** Do not install the SC-EQ Comm Card directly into an equipment's enclosure without the use of an approved installation kit.

### WIRING



***Risk of Electric Shock. Disconnect or isolate all power supplies before making electrical connections. More than one disconnect or isolation may be required to completely de-energize equipment. Contact with components carrying hazardous voltage can cause electric shock and may result in severe personal injury or death.***



***Risk of Property Damage. Do not apply power to the system before checking all wiring connections. Short circuited or improperly connected wires may result in permanent damage to the equipment.***

**IMPORTANT:** Make all wiring connections in accordance with local, national, and regional regulations.

Install the wiring so it does not cause a hazard, and is protected against electrical and mechanical damage.

### Power

The SC-EQ circuit board is powered from either a 12 VDC, or a 24 VAC, Class 2 power source. When used with an OptiView chiller, the Micro Panel supplies low-voltage power via a power harness supplied by the OptiView installation kit. If the SC-EQ circuit board is installed in its own enclosure, a transformer is included in the enclosure. Line voltage may be supplied using an external power source, or drawn from the input voltage terminal strip inside the chiller panel. Be sure the capacity of the power conductors supplying the equipment is rated for the additional power (VA) required by the SC-EQ Comm Card. Use a wire that is one size larger than required for the amperage draw (maximum 400 mA) to connect the line voltage feed

to the SC-EQ Comm Card. For the line voltage power source, use a dedicated line (with a separate fuse) that is isolated (using a control transformer) from other equipment in the plant room that may generate Electromagnetic Interference (EMI).

### Grounding

For the enclosure style, a ground wire must be connected directly to the enclosure supply power ground lug at the point of entry. A label (*Figure 1 on page 9*) identifies this grounding point. This ground wire should be connected through a continuous ground circuit to the incoming ground at the source transformer.

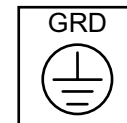

LD20000

**FIGURE 1 - GROUNDING LABEL**

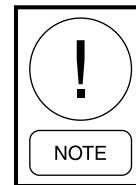

***Besides providing safety protection, the ground connection plays an extremely important part in the operation of the communication circuitry.***



***Risk of Electric Shock. Ground the SC-EQ Enclosure according to local, national, and regional regulations. Failure to ground the SC-EQ Enclosure may result in electric shock and severe personal injury or death.***

### PROTECTION OF COMMUNICATION PORTS

When using RS-485 technology, it is possible that electrical disturbances, such as voltage spikes, can damage a circuit board. The SC-EQ Comm Card includes resettable fuses and other devices on each RS-485 port to protect against damaging electrical spikes and stray voltage. The equipment panel should also be equipped with protection against electrical disturbances. Whereas OptiView Micro Panels are equipped with onboard tranzorbs, other equipment panels may require the addition of an external board. Refer to the equipment documentation for details. The BAS Port J12 of the SC-EQ Comm Card is also electrically isolated, providing a means of mitigating common mode voltage induced problems.

## HIGH NOISE ENVIRONMENTS

Electrical equipment that employs high speed switching circuits (Variable Speed Drives [VSD], Solid State Starters [SSS], and computing equipment) generates Electro-magnetic Interference (EMI) noise and Radio Frequency Interference (RFI), which can generate transient voltage between ground points in the communication wiring. The RS-485 circuitry is designed to withstand some low transient voltage, but if this difference exceeds certain limits, it can permanently damage the RS-485 circuitry.



**Ensure that the Micro Panel and the SC-EQ Comm Card are powered from a source with a true earth ground.**

**IMPORTANT:** Do not run communication cables in close proximity to, or parallel with, high-voltage power cables (maintain at least 457.2 mm [18 in.] of separation, or use a grounded metal conduit).

## ELECTRICAL NOISE MITIGATION TO EQUIPMENT

The likelihood of transient voltage is greatly reduced if the SC-EQ Comm Card is close-coupled to the Micro Panel. Close-coupling requires that the SC-EQ Enclosure and Micro Panel share the same line voltage power source and are physically close to one another. Typically, the SC-EQ Enclosure is mounted on the Micro Panel enclosure. This scenario ensures a short communication cable, which is usually protected entirely within the two enclosures.

## ELECTRICAL NOISE MITIGATION SC-EQ TO BAS

When the SC-EQ is used in an electrically hostile environment (for example, with VSD-enabled equipment), a double-shielded cable should be used to help mitigate the adverse effects electrical noise can have on the system. The double-shielded cable should connect the SC-EQ's BAS port (J12) to the next controller(s) in the daisy-chained network.

The outer shield of the double-shielded cable should be grounded directly at the low noise end (the end most distant from the VSD), and ideally, indirectly through an appropriate capacitor at the high noise end (the end closest to the VSD). If a capacitor is not available, the outer shield may be left unconnected, or tied directly to ground. The best results on the site determine the specific termination strategy employed.

The inner shield of the double-shielded cable should be grounded directly at the low noise end (the end most distant from the VSD), and left open at the high noise end (the end closest to the VSD).

## TYPES OF COMMUNICATION PORTS

The SC-EQ Comm Card uses two electrical communication protocols to connect to other devices: RS-485 which is used for multi-drop networking, and RS-232 which is primarily used for point-to-point connectivity.

### RS-485

The RS-485 standard uses three conductors to connect network nodes: two signal wires and a third called COM which is the reference. The SC-EQ Comm Card uses either a third wire for the reference or the building's infrastructure. The wiring method depends on the port being used: an electrically isolated RS-485 BAS Port J12 typically uses a third wire, whereas the RS-485 Equipment Port J8 and the RS-485 Connected Services Port J11 normally use chassis or building ground for the reference.

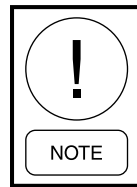

**For BAS systems that use a 2-wire RS-485 network, connect a 100 ohm 1W resistor between SC-EQ J12 COM and J10 COM with a wire that then runs to Ground in the panel. (see Figures 4 and 5)**

### RS-232

The RS-232 Standard also uses three conductors to connect network nodes: two signal wires and a third called COM which is the reference. RS-232 is more susceptible to noise interference than RS-485 so proper shielding and wire routing is essential for proper operation. The RS-232 Standard limits the cable run to a maximum of 50 feet. The OptiView panels use RS-232 to communicate with the SC-EQ.

## NETWORK TERMINATION

Terminate all End-of-Line (EOL) devices at each end of the RS-485 bus (that connect to only one set of RS-485 network wires). EOL termination provides biasing of the network, and assists in returning the signal to a normal state in the event of voltage transients. If the SC-EQ Comm Card happens to be an end-of-line device on the Building Automation System network, terminate the network by setting the BAS EOL switch S2 to ON.

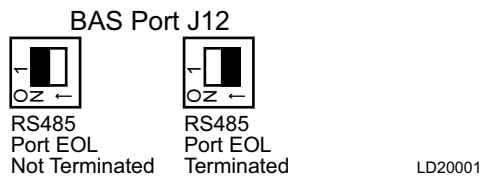

**FIGURE 2 - RS-485 EOL SWITCHES**

**IMPORTANT:** Ensure that the EOL switches are not set to the ON position for controllers that are not at the end of the BAS RS-485 network.

**MEDIA ACCESS CONTROL (MAC) ADDRESS**

The SC-EQ Comm Card’s network hardware address is set on a single 8-way DIP switch. Switch 8 is not used. The switches are binary weighted allowing the setting of addresses from 1 to 127. The address must be provided by the BAS contractor. If an address is not provided at chiller commissioning, leave the MAC address set to 0 (all switches OFF) and leave a copy of the last page of this manual taped on the chiller panel for the controls contractor. The last page explains how to set the MAC address. The SC-EQ will automatically determine what BAS protocol is present and what chiller is connected except older Yorktalk2 chillers will require that the chiller model manually be set using an SC-AP as explained in the SC-AP section of this manual. This should eliminate the need for a chiller technician to have to return to site after the chiller has been commissioned just to set the BAS Network MAC Address.

**IMPORTANT:** The SC-EQ Comm Card is intended to provide an input to equipment under normal operating conditions. Use this SC-EQ Comm Card only as an operating control. Where failure or malfunction of the SC-EQ Comm Card could lead to personal injury or property damage to the controlled equipment or other property, additional precautions must be designed into the control system. Incorporate and maintain other devices, such as supervisory or alarm systems or safety or limit controls, intended to warn of or protect against failure or malfunction of the SC-EQ Comm Card.

**TABLE 2 - YORK EQUIPMENT MODELS**

MICROBOARD NUMBER <sup>1</sup>	SC-EQ/ INSTALL KIT	EQUIPMENT MODEL
031-02550 031-02050	031-03610-000 392-41230-001	YCWL, YCUL, YCAL, YLAA, YCRL, YLPA, YSAA
031-01095	YK-SCCPNL-0 N/A	YCAS, YCWS, YCRS
031-02478 031-03478	031-03610-000 392-41228-000	YVWA, YVAA, YCIV, YCAV
031-01065	YK-SCCPNL-0 N/A	YIA, YPC, YG, YB
031-01730	031-03610-000 331-03607-000	YN, OM <sup>4</sup> RETROFITS, CR <sup>4</sup>
031-02430		YK, YT, YS, YR, YST, YD, YMC <sup>2</sup>
031-03630		YK, YMC <sup>2</sup>
331-02496	YK-SCCPNL-0 N/A	YPAL
YORK-003	YK-SCCPNL-0 N/A	YEWS-D1, YEAS, YGAS <sup>2</sup>

1. Installing technician must verify board number in unit prior to installation.
2. Software edition of YEWS-D1 (RHSYEWSD1) V1.08 or later), YEAS (RHMASB V1.06 or later), YGAS (RHMYGAS V1.03 or later) are supported.
3. Models with Native communications do not require a SC-EQ or SC-AP when only connecting to a BAS and Connected Services is NOT installed.
4. OM and Competitive Retrofit available in future release 3.

**BAS NETWORK WIRING**

3-Wire with Shield BAS

**NOTE:** The EOL switch should be set to ON for this end of line unit.

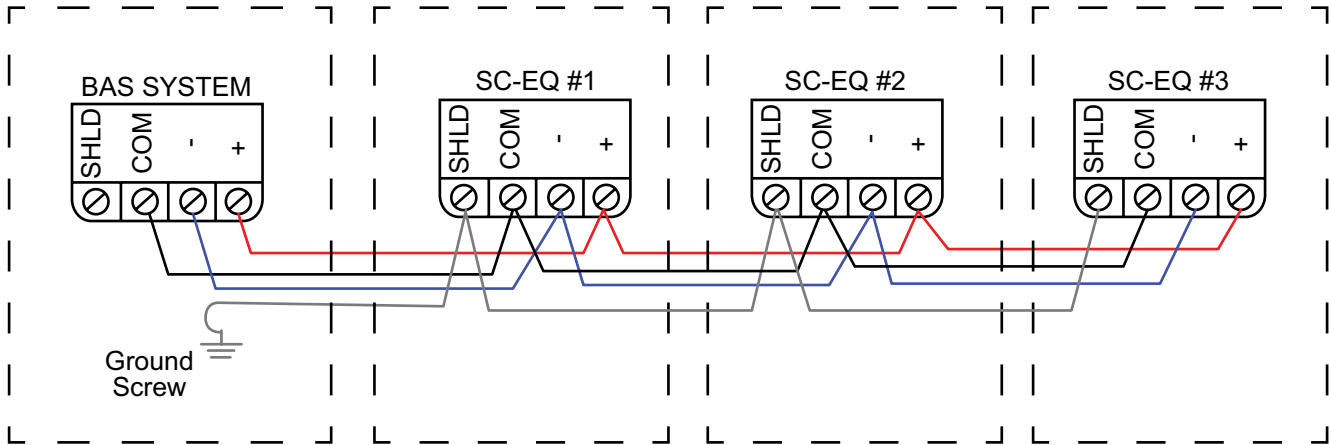
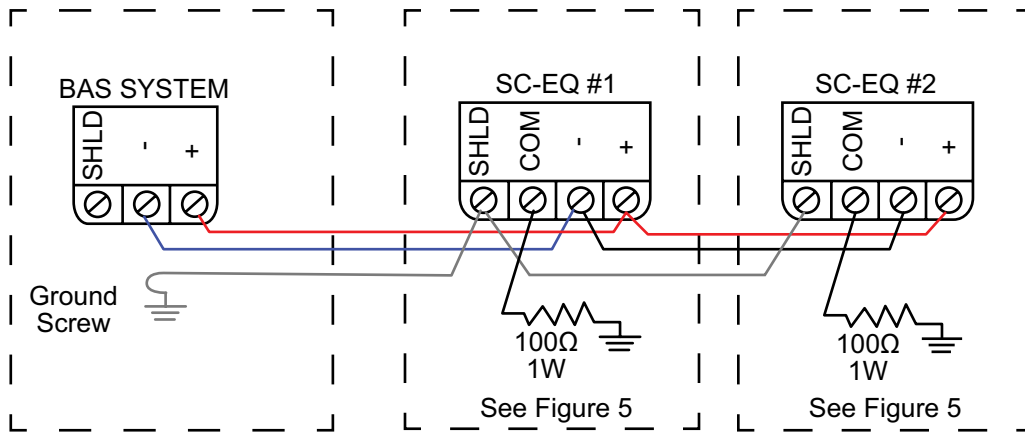

**FIGURE 3 - 3-WIRE BAS**

- NOTE:**
1. The shield terminal on the SC-EQ is not connected to ground. It provides a convenient place to connect shields in two daisy chain segments.
  2. Do not set the EOL switch ON if the unit is not at the end of the segments.

2-Wire with Shield BAS

**NOTE:** The EOL switch should be set to ON for this end of line unit.



**FIGURE 4 - 2-WIRE BAS**

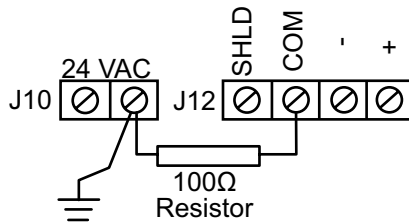

LD19868

**FIGURE 5 - 100 OHM RESISTOR INSTALLATION**

**MOUNTING**



**Risk of Electric Shock. Disconnect or isolate all power supplies before making electrical connections. More than one disconnect or isolation may be required to completely de-energize equipment. Contact with components carrying hazardous voltage can cause electric shock and may result in severe personal injury or death.**

**OPTIVIEW PANEL INSTALLATION**

1. Attach the SC-EQ Comm Card board to the studs provided inside the chiller enclosure (*Figure 6 on page 13 or Figure 7 on page 13*), using the four screws and washers provided in the OptiView/Latitude installation kit.
2. Connect the appropriate communications cable (included with the kit) based on the SC-EQ mounting location, from Port J7 (RS-232) on the SC-EQ Comm Card to J2 on the OptiView Micro Panel. Ensure that wires are connected according to *Table 3 on page 13*.
3. Check for stray wire strands, which could cause short circuits, and ensure all components are secure.
4. Connect the BAS network to J12 (RS-485) on the SC-EQ board.

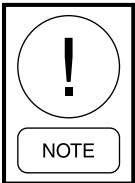

**For BAS systems with 2-wire RS-485 network cables remember to install the 100 ohm resistor as shown in Figures 4 and 5.**

5. Connect the appropriate length power harness (included with the kit) from J9 on the SC-EQ Comm Card to J21 on the OptiView Micro Panel (see *Figure 8 on page 14*).
6. Set the desired BAS network address for the SC-EQ using the SW-1 MAC Address Switches.

When the SC-EQ and the OptiView panel are powered up, the SC-EQ will automatically set itself to the BAS protocol, baud rate and chiller model. This may take up to 120 seconds.

**TABLE 3 - OPTIVIEW WIRING - SC-EQ PORT J7**

SC-EQ PORT J7	OPTIVIEW PORT J2	WIRE COLOR
RX	GTX	Black
TX	GRX	Red
REF	N/A	Shield/Drain

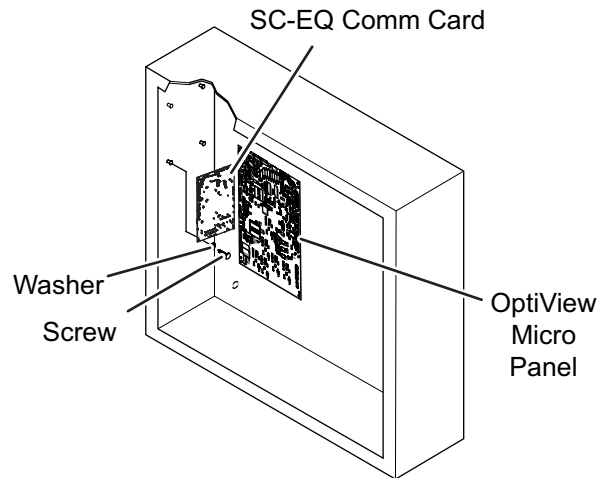

LD19583

**FIGURE 6 - SC-EQ INSTALLED IN OPTIVIEW (ALL CHILLERS EXCEPT YMC2)**

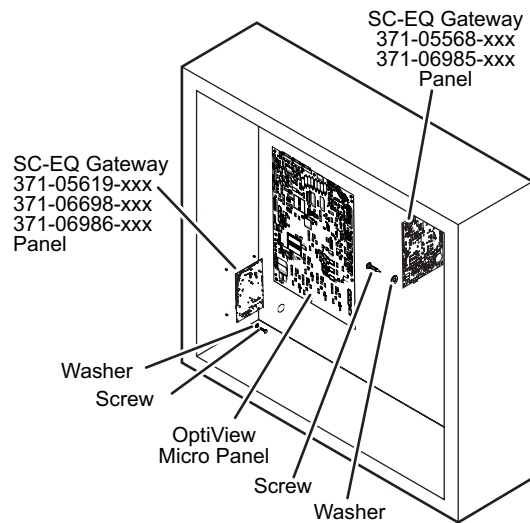

LD19582a

**FIGURE 7 - SC-EQ INSTALLED IN YMC2 OPTIVIEW**

**TABLE 4 - BAS WIRING - SC-EQ PORT J12**

SC-EQ PORT J12	BAS	WIRE COLOR
+	+	White
-	-	Blue
REF	REF	Black



**When replacing an E-Link with a SC-EQ, the BAS wiring MUST be changed since the plug terminal locations are not the same!**

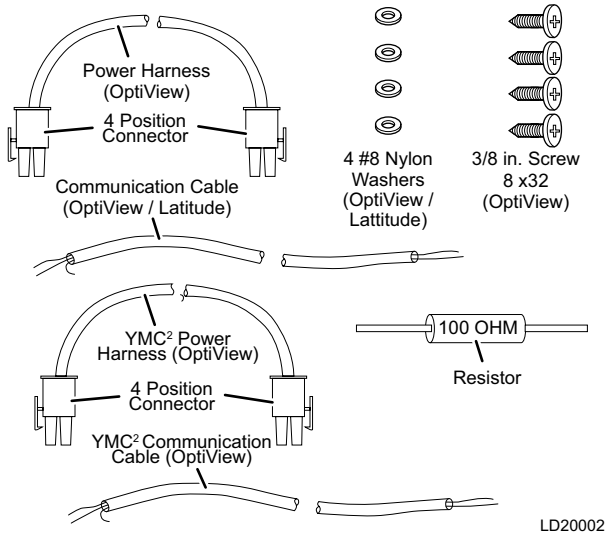

**FIGURE 8 - SC-EQ OPTIVIEW INSTALLATION KIT (ALL CHILLERS) (YORK P/N 331-03607-000)**

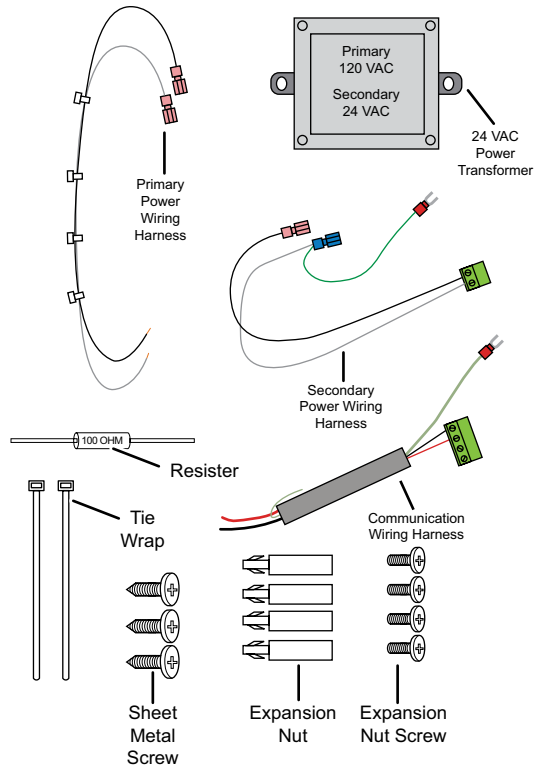

**FIGURE 10 - SC-EQ SCROLL CHILLER INSTALLATION KIT PART NUMBER 392-41230-001**

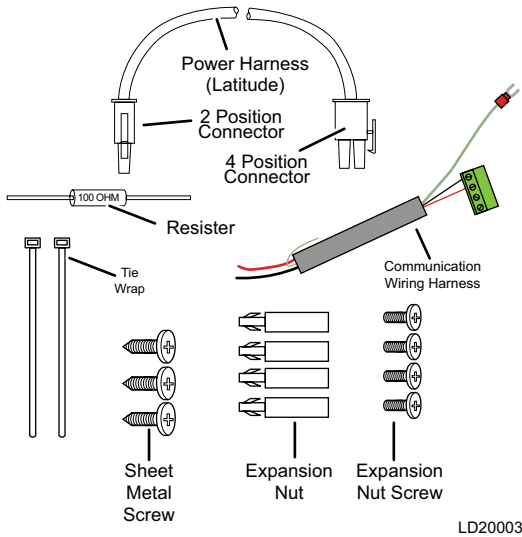
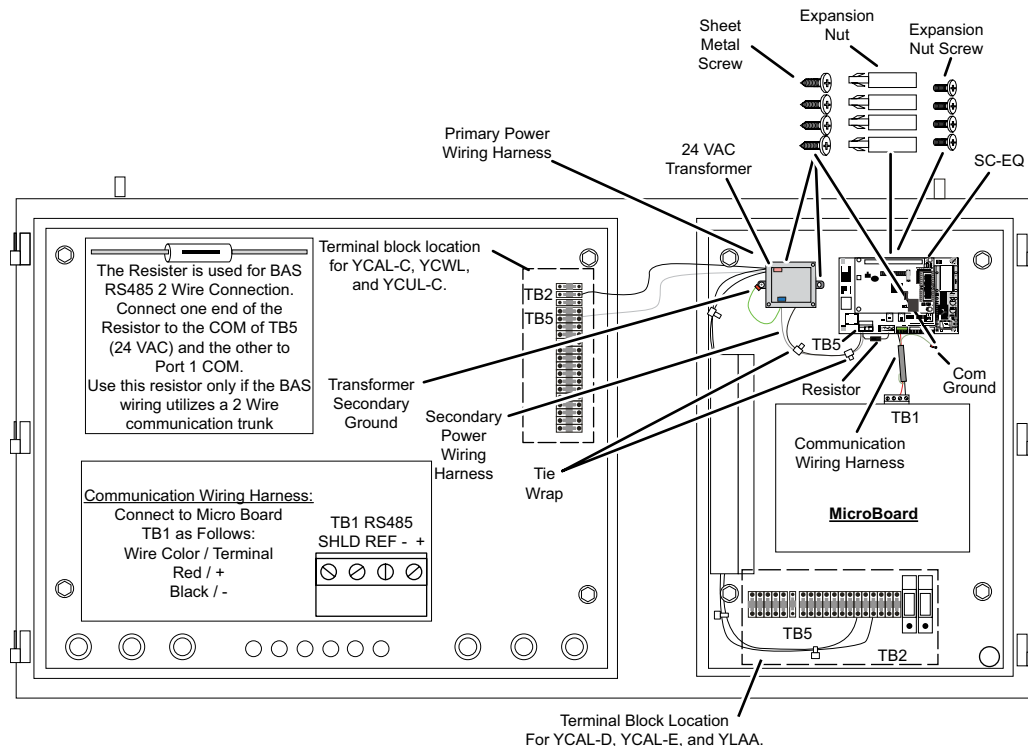

**FIGURE 9 - SC-EQ SCREW CHILLER INSTALLATION KIT PART NUMBER 392-41228-000**

### SMALL TONNAGE PANEL INSTALLATION

1. Attach the SC-EQ Comm Card board to the panel in the upper right side of the enclosure using the four expansion screws and nuts provided in the IPU-II Panel Installation Kit (see *Figure 11* on page 15).
2. Attach the 24 VAC transformer to the panel to the left of the SC-EQ board using two screws (*Figure 10* on page 14).
3. Connect the communications cable (included with the kit) between the SC-EQ board J8 (RS-485) and the IPU-II Micro board TB1.
4. Connect the transformer to the terminal block.
5. Connect the transformer to SC-EQ J10 and secure the wiring with tie-wraps.
6. For RS-485 2-wire operation, connect a 100 ohm 1W resistor between SC-EQ J12 COM and J10 COM with a wire then run to Ground in the panel. (see *Figure 4* on page 12 and *Figure 5* on page 12)
7. Connect the communications cable shielded ground to the ground screw.
8. Set the desired BAS network address for the SC-EQ using the SW-1 MAC Address Switches.

When the SC-EQ and the control panel are powered up, the SC-EQ will automatically set itself to the BAS protocol, baud rate and chiller model. This may take up to 120 seconds.



LD20005

**FIGURE 11 - SCROLL CHILLER PANEL INSTALLATION**

## OTHER CHILLER PANEL INSTALLATION

For all other applications, the SC-EQ Comm Card includes an optional enclosure. The optional enclosure does not include communication cables due to the variety of types and lengths that may be required.

Never install the SC-EQ Comm Card outside the confines of a building unless within another enclosure rated IP 65/NEMA 4x or higher.

The SC-EQ Comm Card can be mounted as a stand-alone enclosure either on the outside surface of the chiller Micro Panel (close coupled), or on a smooth surface within close proximity of the chiller panel enclosure.

For mounting on a Micro Panel, the line voltage power is supplied by a power source in the Micro Panel.

**IMPORTANT:** Make sure that the cover is securely fastened to the enclosure and the internal ground wire is attached before placing the SC-EQ in operation. These steps help to minimize Radio Frequency Interference (RFI) from being generated and picked up.

## MOUNTING ON A MICRO PANEL



**Risk of Electric Shock. Disconnect or isolate all power supplies before making electrical connections. More than one disconnect or isolation may be required to completely de-energize equipment. Contact with components carrying hazardous voltage can cause electric shock and may result in severe personal injury or death.**

**IMPORTANT:** When attaching the SC-EQ Enclosure to a Micro Panel, ensure the SC-EQ Enclosure does not impede access to other components.

To mount the SC-EQ Enclosure on a Micro Panel:

1. Disconnect power to the chiller Micro Panel.
2. Make sure the SC-EQ Enclosure fits properly and that no obstructions, such as internal boards, switches, or external conduit, prevent mounting or servicing of the panel. See *Figure 12 on page 16* for examples of good mounting locations.
3. Locate and remove the two plastic caps in the bottom of the SC-EQ Enclosure.
4. Mark an appropriate place on the enclosure for a matching set of knock out holes. Mark and drill, or punch, two holes in the Micro Panel.

5. Using two bulkhead pipe couplers, attach the SC-EQ Enclosure to the Micro Panel.
6. Complete wiring as described in the Applying Power section in this document.

**IMPORTANT:** Be careful not to damage the SC-EQ or Micro Panel's circuit boards during the installation. Protect all circuit boards from metal chips, which may cause short circuits if left on the boards at startup.

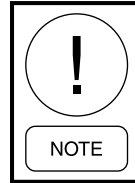

**Use of bulkhead pipe couplers provides sufficient clearance to allow removal of the SC-EQ Enclosure cover.**

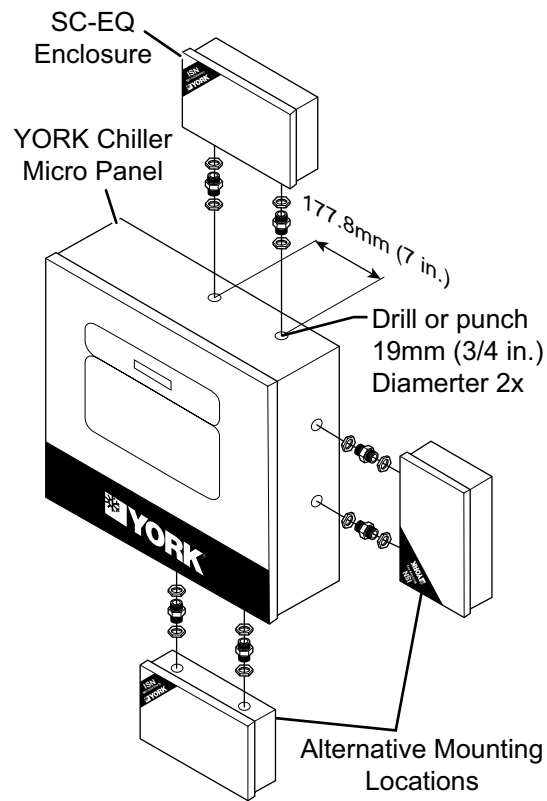

LD20006

**FIGURE 12 - MOUNTING ON THE EQUIPMENT**

## WALL MOUNTING

To mount the SC-EQ Enclosure on a wall:

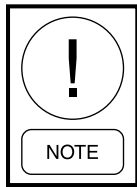

**When wall mounting, make sure there is no interference with other components in the near vicinity. Use appropriate conduit to connect the power and communications wiring.**

1. Check for proper clearances for the necessary electrical and communications cable runs.
2. Ensure that power and communications wiring is in compliance with all local, national, and regional codes, and customer requirements.
3. Select a suitable location and mark the anchor points. Ensure that the enclosure is level. See *Figure 13 on page 17* for an example.
4. Drill the appropriate holes in accordance with the type of wall anchor used.
5. Install the enclosure on the wall.
6. Check that the mounting is secure and the wiring connections are correct and tight. Check that no loose wire strands or other metal objects that could cause a short circuit are on the circuit board.
7. Complete wiring as described in the Applying Power section.

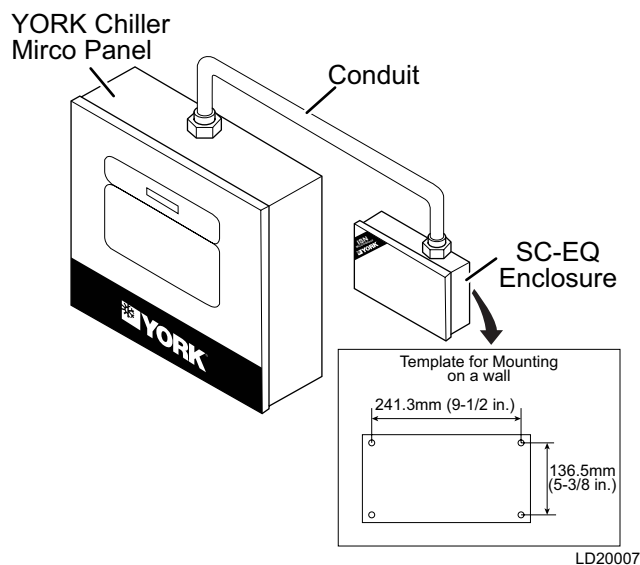

**FIGURE 13 - WALL MOUNTING**

## APPLYING POWER

When using an enclosure type of SC-EQ, power can be supplied from either a separate power supply or the main terminal strip in the chiller panel. Locate the power source within 0.9 m (3 ft) of the SC-EQ Enclosure, and protect it with a suitable fuse or circuit breaker. Ensure the power is supplied from a dedicated source and not controlled by a programmed switch.

If the enclosure is mounted on a wall, the wiring from the power source to the SC-EQ Enclosure must always run in a suitable conduit. To obtain the best Electromagnetic Interference (EMI) and Electromagnetic Compatibility (EMC) performance, ensure that the conduit is bonded to the metal of both enclosures. Scraping the paint around the knockouts usually helps provide a better electrical connection between the joining parts.



**Risk of Electric Shock. Disconnect or isolate all power supplies before making electrical connections. More than one disconnect or isolation may be required to completely de-energize equipment. Contact with components carrying hazardous voltage can cause electric shock and may result in severe personal injury or death.**

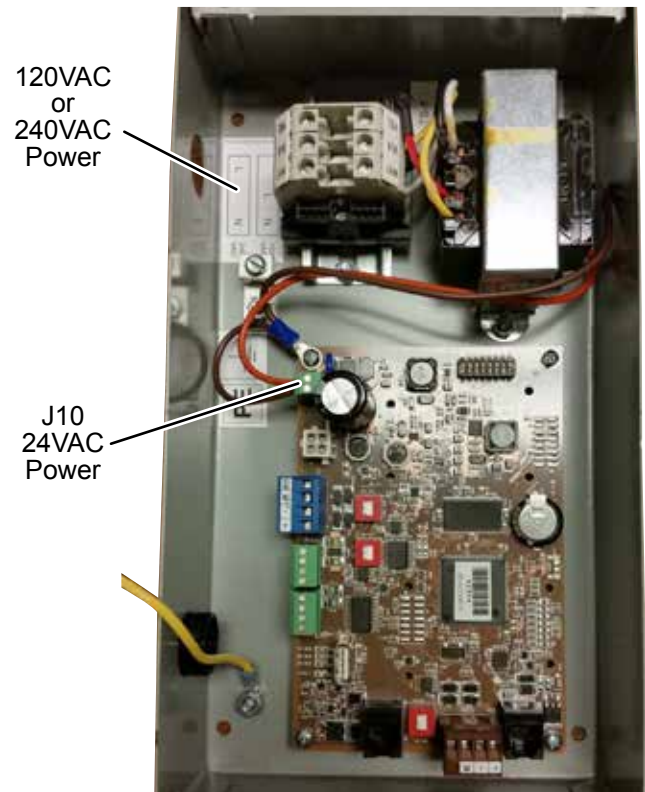

**FIGURE 14 - SC-EQ IN ENCLOSURE**



**Risk of Property Damage. Do not apply power to the system before checking all wiring connections. Short circuited or improperly connected wires may result in permanent damage to the equipment.**

1. Connect a 1.29-1.02 mm (16-18 AWG) wire from a reliable ground reference to the SC-EQ Gateway's incoming power ground lug. Do not remove the existing wire that connects the ground lug to the enclosure cover.

2. On 120 VAC applications, connect the Hot wire to TB-BLK and the Neutral wire to TB-WHT. Connect the ground wire to the ground lug.

On 240 VAC applications, connect the Hot wire to TB-YEL and the Neutral wire to TB-WHT. Connect the ground wire to the ground lug.

**IMPORTANT:** Use copper conductors only. Make all wiring connections in accordance with local, national, and regional regulations. Do not exceed the SC-EQ Gateway's electrical ratings.

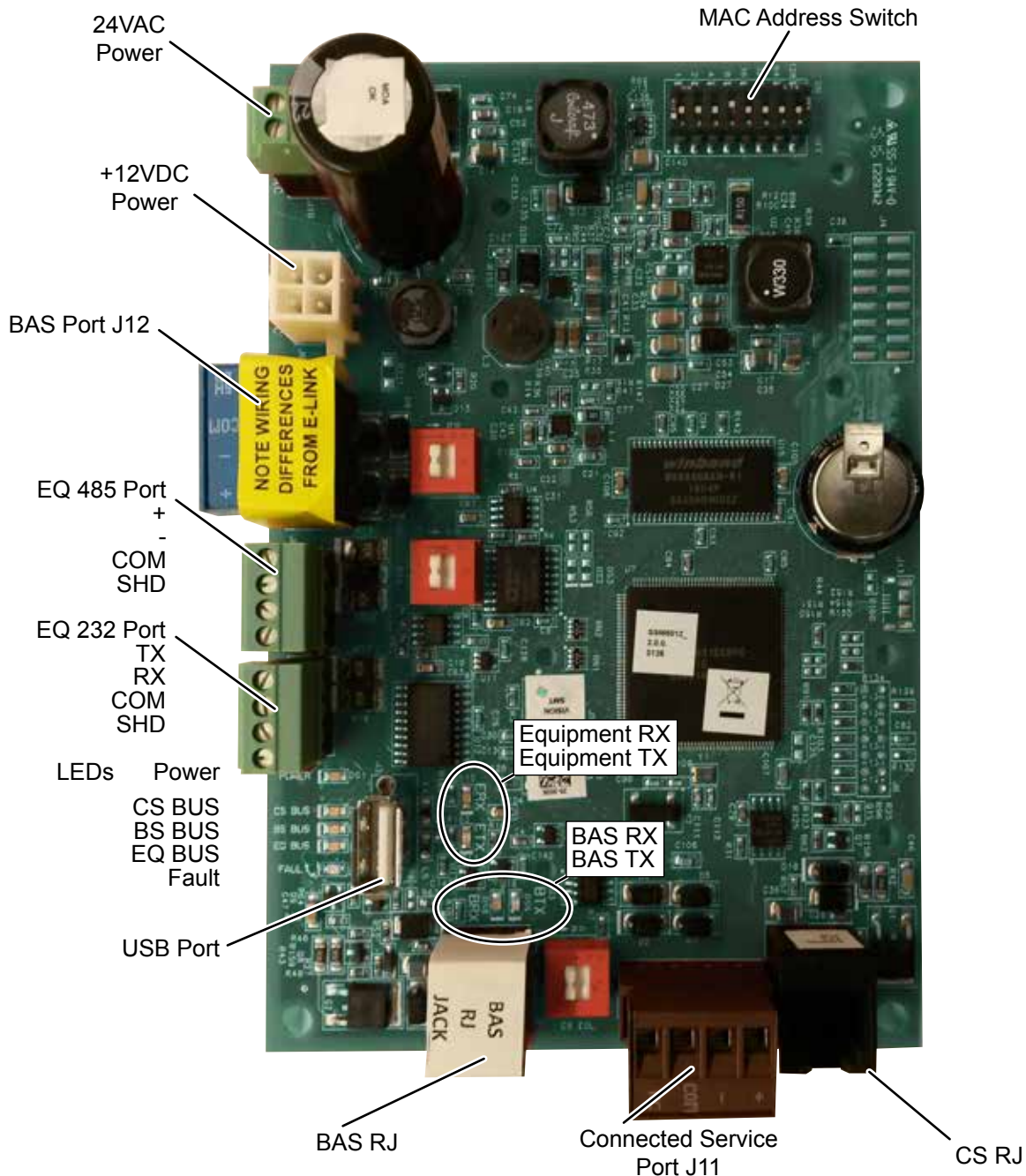

LD19992a

**FIGURE 15 - SC-EQ COMPONENT LOCATIONS**

## EQUIPMENT CONFIGURATION

Different pieces of equipment sometimes require a specific hardware configuration (jumper, switch or software setting) to enable communication with the SC-EQ Communication Card. Refer to the equipment's installation literature for details on the proper configuration settings. The following diagrams summarize what these requirements are and the wiring interfaces for each of the different types of microboards.

Chiller Rotary Switch

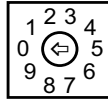

YT Address = Rotary Switch +1

LD20009

**FIGURE 16 - MICROPANEL ROTARY SWITCH**

## SETTING THE ROTARY SWITCH ON CHILLER PANELS

Some Micro Panels use a rotary switch to set their YORK Talk II address (YORK Talk address = Rotary Switch setting + 1). Since the SC-EQ uses a one-to-one relationship with the chiller panel, this switch is normally set to 0 (YORK Talk address 1). However, when two microboards are used in a master/slave configuration, set the master microboard rotary switch to 0, and the slave microboard is set to 1. If the chiller microboard is not equipped with a rotary switch, the YORK Talk address is set using the Micro Panel keypad and display. In most cases, you can configure the setting, but some models are fixed and cannot be changed (refer to the equipment documentation for specific details).

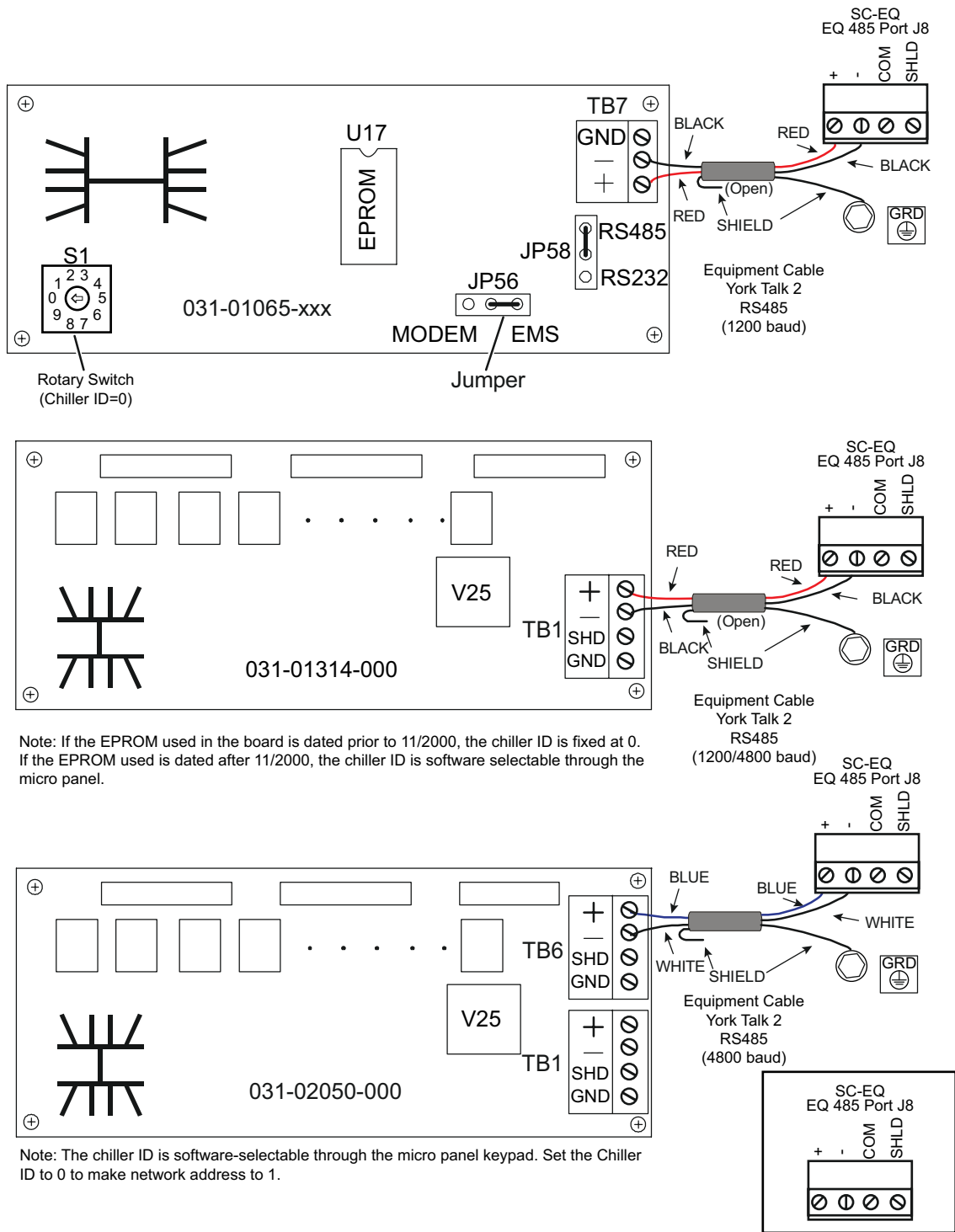

LD20010

**NOTE:** See Table 2 on Page 11 for board cross-reference.

**FIGURE 17 - SC-EQ COMM CARD TO YORKTALK II EQUIPMENT CONNECTIONS**

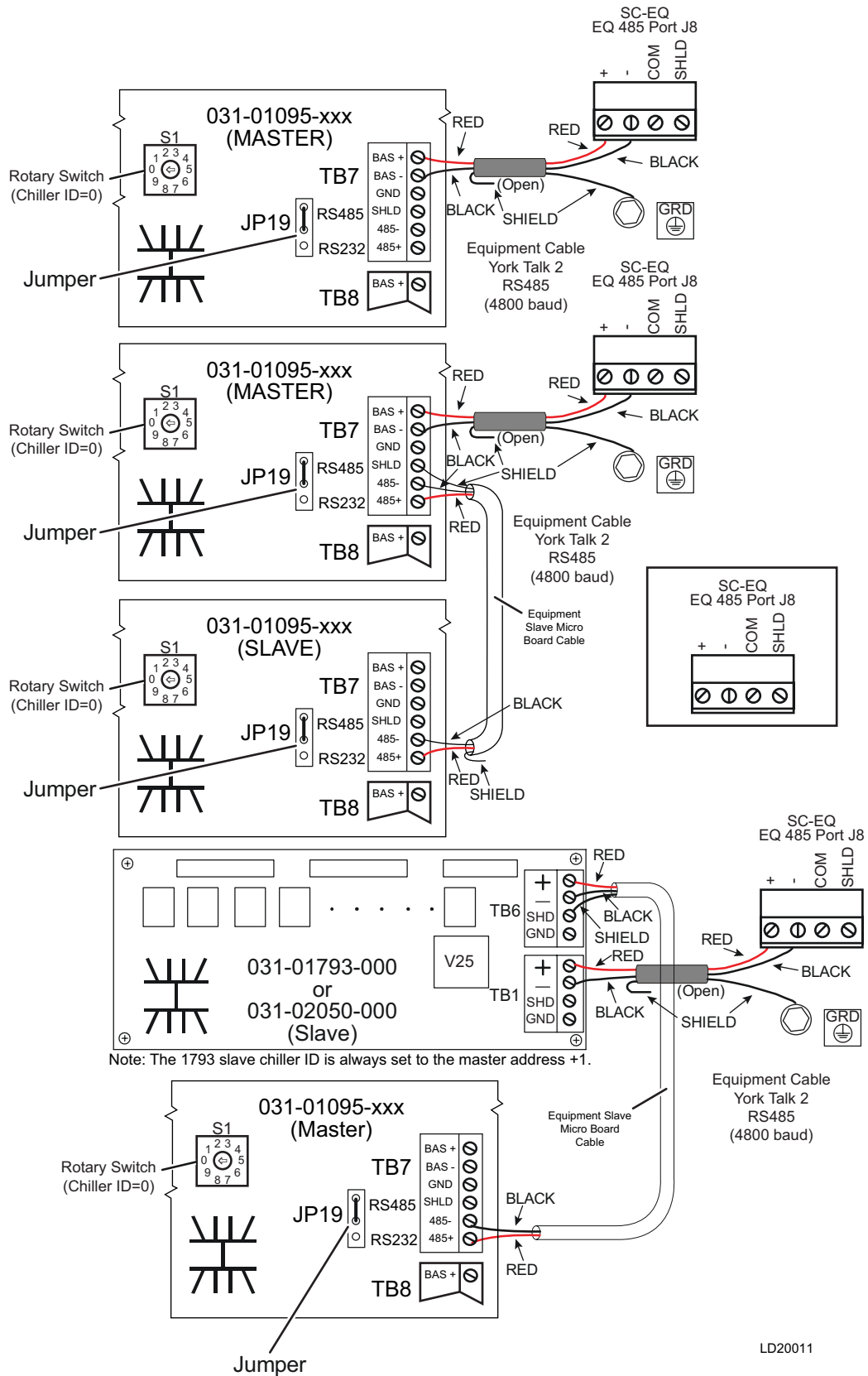

LD20011

**NOTE:** See Table 2 on Page 11 for board cross-reference.

**FIGURE 18 - SC-EQ COMM CARD TO YORKTALK II EQUIPMENT CONNECTIONS**

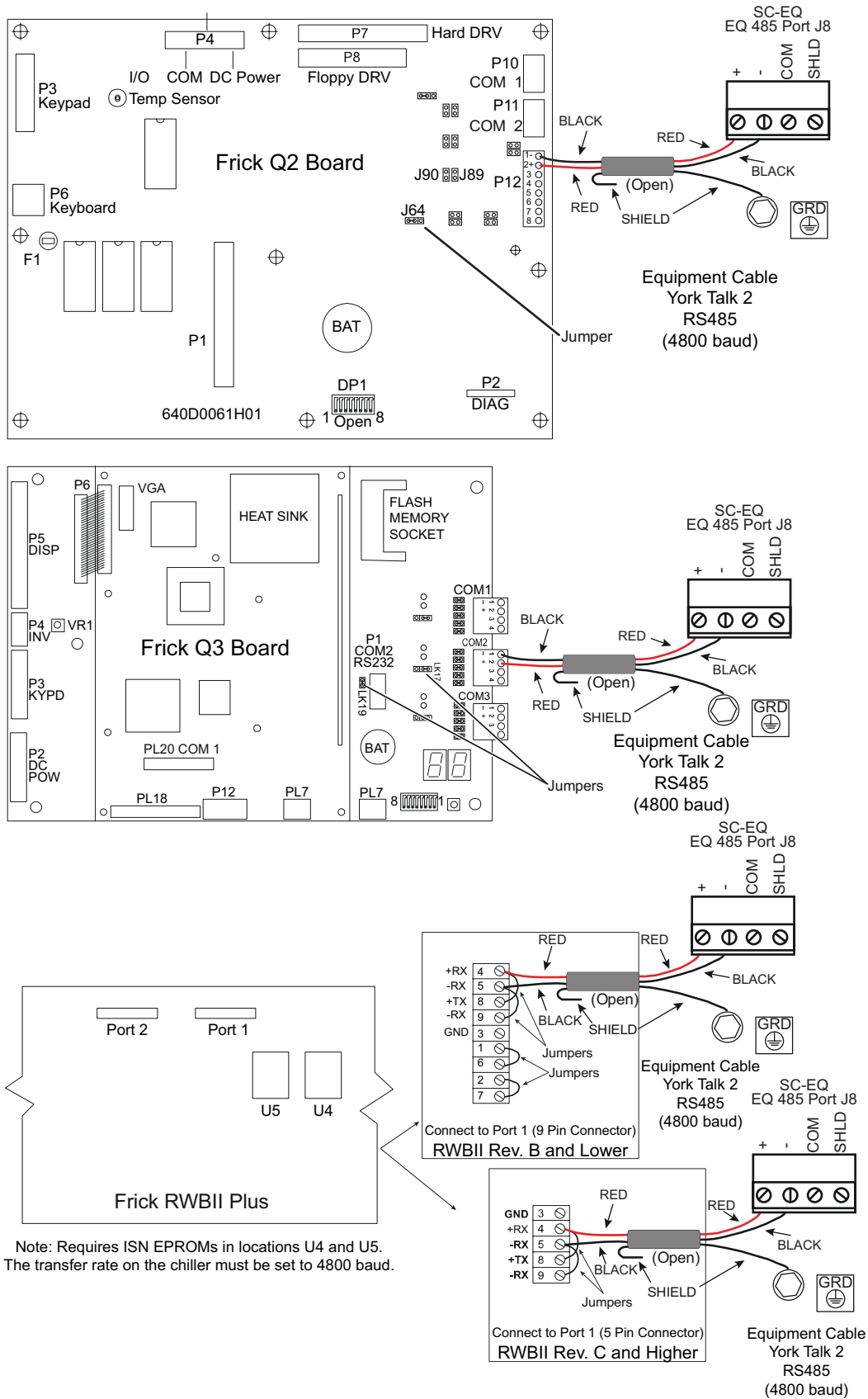

NOTE: See Table 2 on Page 11 for board cross-reference.

LD20012

FIGURE 19 - SC-EQ COMM CARD TO YORKTALK II EQUIPMENT CONNECTIONS

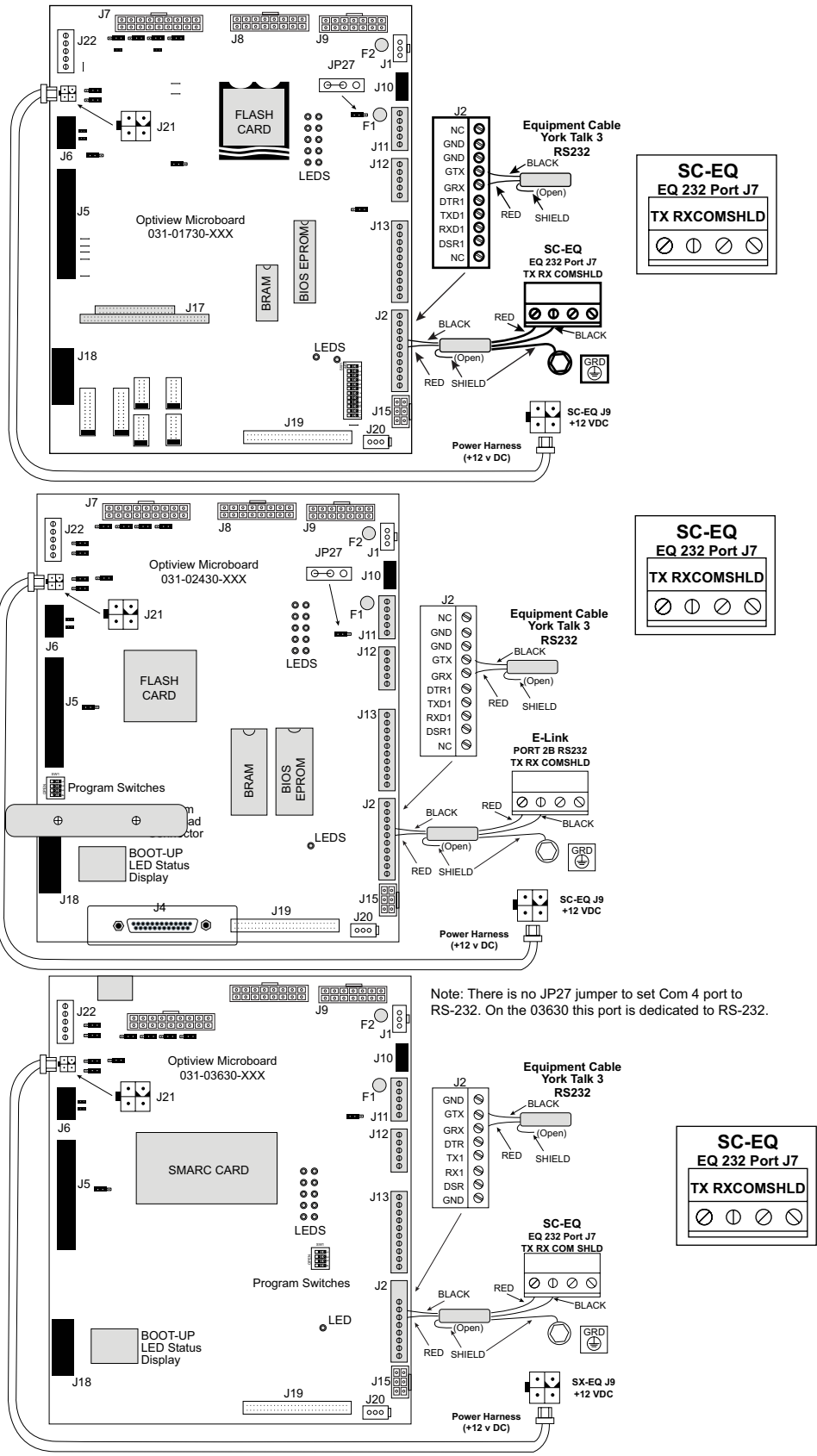
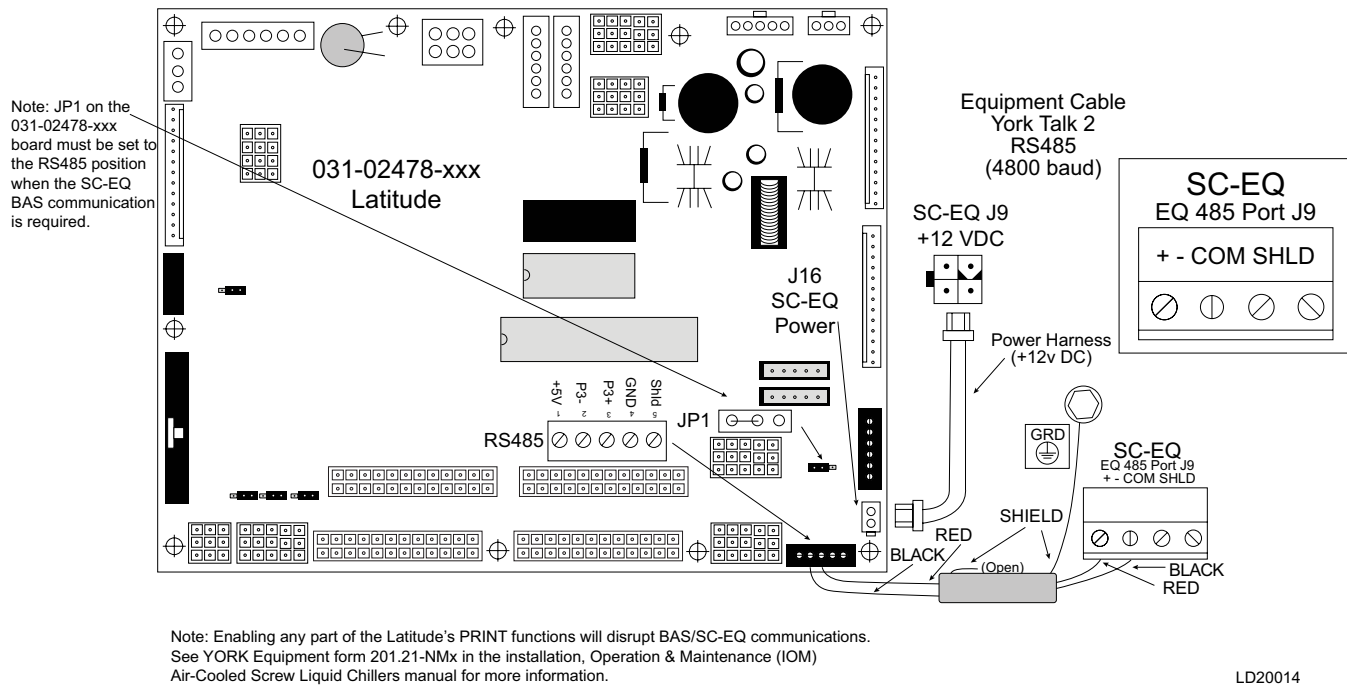
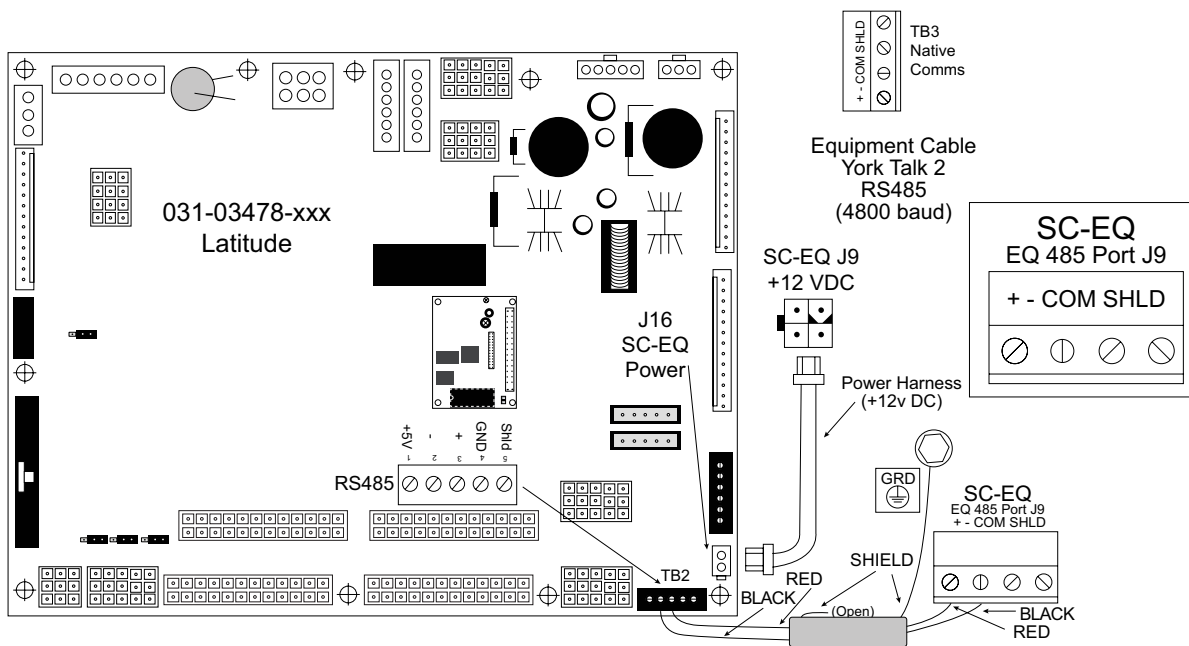

FIGURE 20 - SC-EQ COMM CARD TO OPTIVIEW EQUIPMENT CONNECTIONS



**FIGURE 21 - SC-EQ COMM CARD CONNECTIONS FOR CHILLERS WITH THE 02478 MICROBOARD YCAV/ YCIV/YVAA/YVWA**



**FIGURE 22 - SC-EQ COMM CARD CONNECTIONS FOR CHILLERS WITH THE 03478 MICROBOARD YCAV/ YCIV/YVAA/YVWA/YVFA**

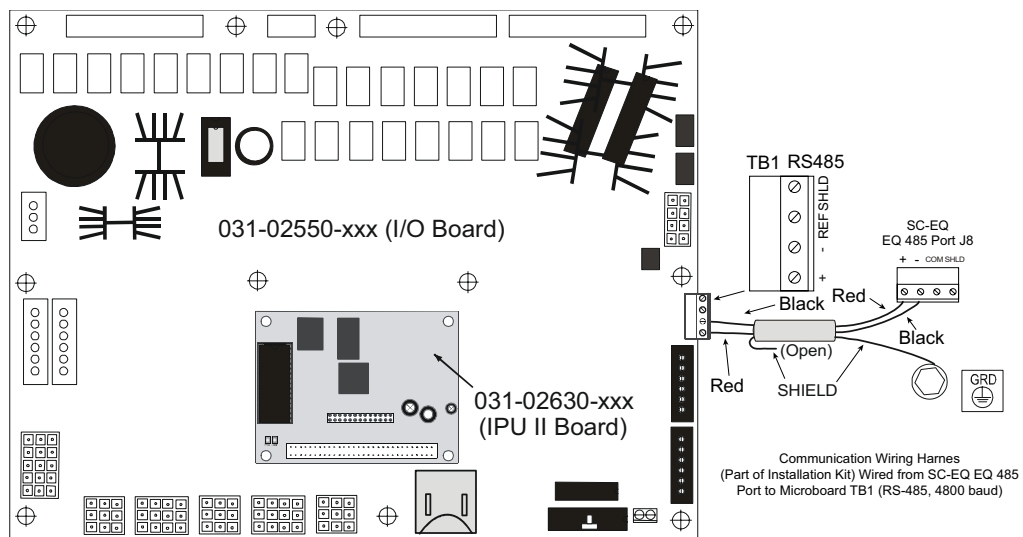

IPU-II P1 Setup for York Talk 2: LD20016

- DE Modifier Address set to -1.
- DE Modifier Offset set to -1.
- P1 Protocol set to API.
- P1 Manual MAC Address set to -1. Some panel programs may not allow the -1 setting in which case it should be set to 0.
- P1 Baud Rate set to 4800.
- P1 Parity set to Odd.
- Cycle power to the IPU-II

NOTE: The IPU II Chiller address defaults to 0, which is the Yorktalk equivalent of an ID of 1. Do not change this default ID. If you believe this has been modified, reset it to 0. Also, set the Chiller Local/Remote setting to Remote to send commands to the chiller.

**FIGURE 23 - SC-EQ COMM CARD CONNECTIONS FOR CHILLERS WITH THE 02550 MICROBOARD YCAL/YCUL/YLAA/YLPA/YCWL/YCRL/YSAA**

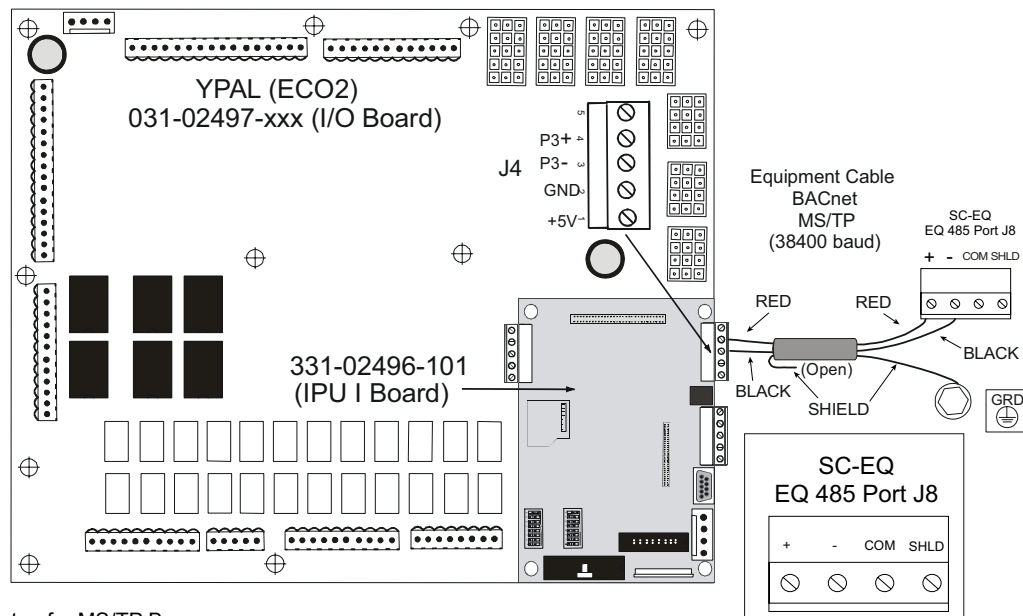

YPAL (ECO2) Setup for MS/TP Bus: LD20017

- DE Modifier Address set to 50.
  - DE Modifier Offset set to -1.
  - P1 Protocol set to BACnet.
  - P1 Manual MAC Address set to -1.
  - P1 Baud Rate set to 38400.
  - P1 Parity set to None.
  - P1 Stop Bits set to 1.
  - MAC Address Switch (SW2) set 1 ON, all others OFF.
- NOTE: Do not set the Chiller address and the SC-EQ address to the same value. This causes a conflict on the MS/TP Bus resulting in no communication between the chiller IPU I board and the E-Link Gateway.

**FIGURE 24 - SC-EQ COMM CARD CONNECTIONS TO YPAL (ECO2)**

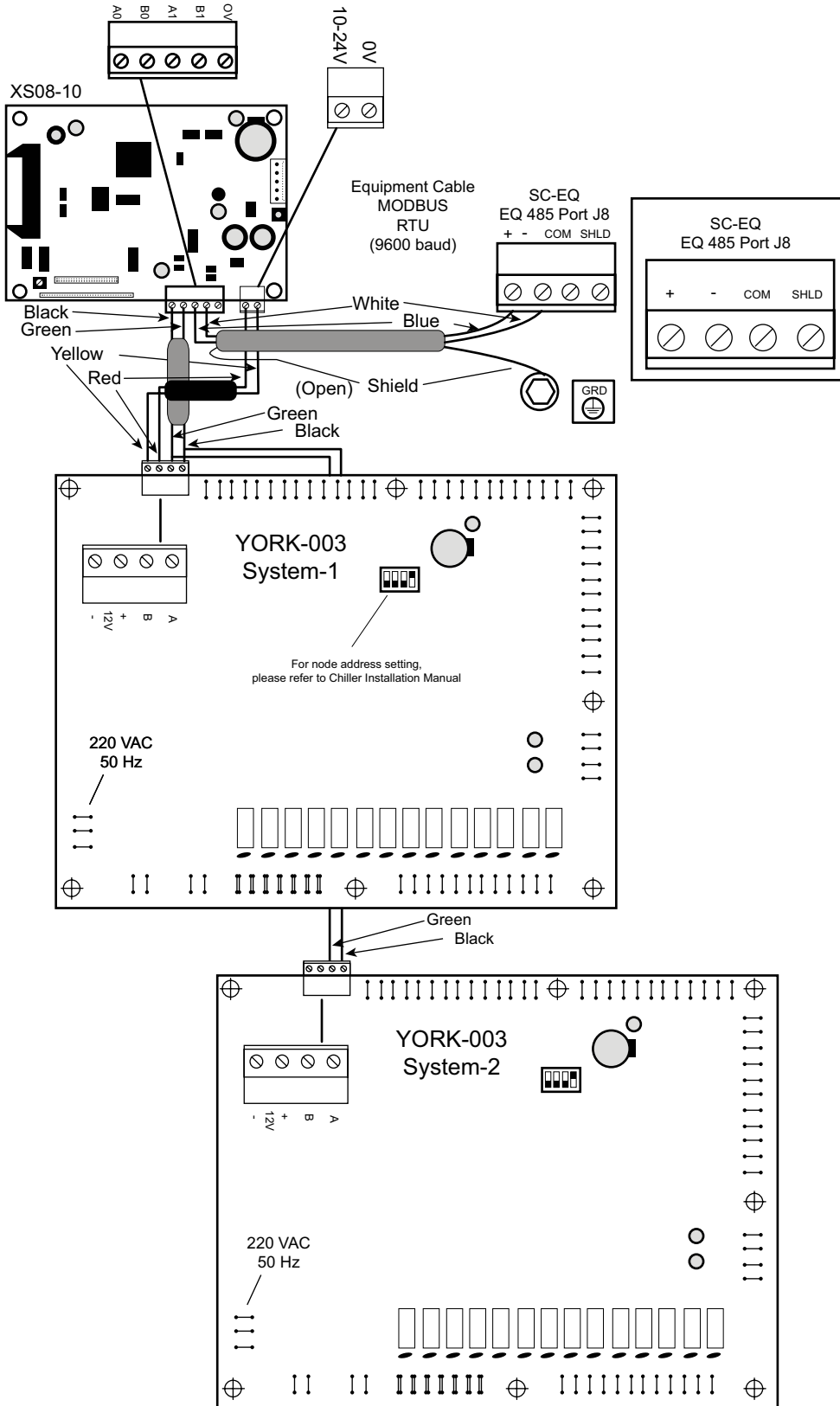

LD20018

FIGURE 25 - SC-EQ COMM CARD CONNECTIONS TO YEW-S-D1/YEAS/YGAS

## SECTION 3 - TROUBLESHOOTING

### LED INDICATORS

There are 9 LEDs on the SC-EQ Comm Card to indicate the operational status of the SC-EQ and the 3 communication ports. The LEDs on the SC-EQ and related communication LEDs on the chiller microboard should be observed to help diagnose communication problems.



FIGURE 26 - SC-EQ LEDS AND USB

#### Power

A Green LED that will be ON whenever power is applied to the SC-EQ Comm Card either by the 24VAC (20.4 to 30 VAC) input or the +12VDC (+12VDC  $\pm$  or 10%) input. The Power LED should always be illuminated. If not then a digital multimeter should be used to verify the power source to the SC-EQ is present or not. If the power source is present at the SC-EQ power terminals (J9 +12VDC (Red wire + Black wire - ) or J10 24VAC as applicable) and the Power LED is not illuminated then the SC-EQ is faulty.

#### Connected Services Network

**CS BUS** - A Green LED that indicates the communication activity on the Connected Services communication port. It blinks ON and OFF every 500ms to indicate that communications is established with the SC-AP. The LED is ON solid when there are no communications established with the SC-AP and the SC-EQ CS port is therefore polling for a Master. If the LED is OFF continuously then the SC-EQ is waiting for the SC-AP to start polling the SC-EQ.

#### BAS Network

**BS BUS** - A Green LED that indicates the communication activity on the BAS communication port. The LED illumination has two variations depending upon the protocol present on the BAS port.

**BACnet MS/TP** - The LED is OFF when there are no active BACnet communications on the network. It will also be OFF when it is initially auto-bauding and waiting for a master device to poll on the network. The LED will illuminate ON when the SC-EQ sees any communications on the network.

**N2 and Modbus RTU** - SC-EQ receives a request from the Master to the SC-EQ network address. The LED will then illuminate while the SC-EQ is transmitting the response message.

There are two additional LEDs on the BAS Port to aid in diagnosing BAS Network Integration problems.

**BRX** - A Green LED that illuminates when the SC-EQ is Receiving data on the BAS Network Port.

**BTX** - A Red LED that illuminates when the SC-EQ is Transmitting data on the BAS Network Port.

**Normal Sequence** - The Green BRX LED will illuminate whenever there is a data packet sent on the BAS network to Any address. If this LED illuminates for a short period of time then it indicates that the BAS Port RS-485 receive circuitry is functioning. If the BRX illuminates solid, then the + and - RS-485 wires are probably swapped and should be corrected. If the data message address matches the SC-EQ address then the SC-EQ will respond with the requested data and the Red BTX LED will illuminate during the response. If the BAS system is polling the SC-EQ but the SC-EQ is not responding then the MAC address should be checked to see if it is set to the desired address.

#### Equipment Network

**EQ BUS** - A Green LED that indicates the communication activity between the SC-EQ and the chiller Microboard. The SC-EQ acts as the Master in this network and issues data requests to the chiller Microboard. The EQ BUS LED will blink as it receives a valid response from the chiller Microboard. The data is requested one parameter at a time so the blink rate will be almost constant.

There are two additional LEDs on the Equipment Port to aid in diagnosing communication problems with the microboard.

**ERX** - A Green LED that illuminates when the SC-EQ is Receiving data from the microboard.

**ETX** - A Red LED that illuminates when the SC-EQ is Transmitting data to the microboard.

**Normal Sequence** - The Red ETX LED will illuminate when the SC-EQ sends a request for data to the chiller microboard. The microboard Receive LED should then illuminate. The microboard should then illuminate its Transmit LED as it sends the requested data and the Green ERX LED on the SC-EQ should illuminate.

If the SC-EQ ETX light illuminates and the microboard Receive LED illuminates but no response is transmitted from the microboard check that the chiller address is set to 1. For microboards with a rotary switch set to 0 which is interpreted as a 1. If the address is set in the software, then it should be set to 1.

### Fault

A Red LED that indicates a problem with the SC-EQ Firmware or indicates the status during a program update.

**Power-Up** - The LED will blink while the SC-EQ is initializing and performing self checks.

**Normal Operation** - The LED should normally be OFF.

**Firmware Update** - The LED will blink at a 100ms cycle while the Firmware is updating.

**Unable to Load Firmware** - The LED will blink at a 500ms cycle to indicate that the SC-EQ could not load a firmware update. Try loading the firmware update on to another USB thumb drive and perform the update again.

**Firmware Validation Failure** - The LED will blink at a 1 second cycle whenever the SC-EQ fails to validate the firmware at initial power up or after a firmware upgrade. Try cycling power to the SC-EQ and updating the firmware again.

**Firmware Programming Required** - The LED will be ON solid indicating no firmware is present. A firmware update should be performed to remedy this.

## MULTIMETER CHECKS OF THE BAS PORT

If the SC-EQ board is connected to a BAS bus but the BS BUS LED is off steady then the SC-EQ board is not likely seeing any valid communications occurring on the BAS bus. Simple voltage measurements with a DC voltmeter can be made on the SC-EQ board and BAS communication bus to help diagnose the problem.

1. Remove the BAS plug from the SC-EQ J12.
2. Note the position of the BAS End Of Line (EOL) Switch S2. (If the SC-EQ is not the EOL device, the EOL switch must be OFF) If it is the EOL then set the EOL to ON temporarily for these tests.
3. Measure the voltage between the + and – pins on the BAS Bus Terminal Block as shown in the top portion of *Figure 27 on page 29*. The positive lead of the voltmeter should be on the + pin of the block and the negative lead of the voltmeter on the – pin of the block. The voltage reading can fall in the range of (0.38VDC to 0.47VDC). The reading should be steady and only changing by a couple of millivolts at the most. If the reading is within the range of (+0.38VDC to +0.47VDC) that is an indication that the BAS transceiver on the SC-EQ board is not damaged. If the voltage reading is out of the range given by a large amount, the transceiver or its associated circuitry may be damaged. **Again verify that switch S2 (BAS EOL) is in the “ON” position during the measurement otherwise the voltage readings will be out of the given range.**
4. If the reading in step 3 is within the given voltage range then return switch S2 (BAS EOL) to its proper position and connect the BAS terminal block plug back into the BAS terminal block J12 on the SC-EQ board. Take another VDC voltage reading now on the BAS plug between the + and – wire connections as shown in the bottom portion of *Figure 27 on page 29*. If the BAS bus is connected to a JCI BAS bus with proper EOL terminations set then the voltage range should be steady and in the (0.38VDC to 0.47VDC) voltage range if NO communications are occurring on the BAS bus. If the voltage reading is steady but out of the (0.38VDC to 0.47VDC) voltage range then the issue could be improper EOL terminations, issues with wiring or some other issue. If the BAS trunk is connected to a third party BAS then the voltage readings could be acceptable anywhere between (0.25VDC to 0.5VDC).

- If communications are occurring on the BAS Bus then the voltage measured in step 4 should fluctuate generally in the range of (0.1VDC to 0.5VDC) if the bus is properly terminated. The voltage readings may vary somewhat out of this range depending on bus loading and the type of voltmeter used. If the voltage readings are fluctuating in the approximate range of (1.5VDC to 3.5VDC) then it is likely there is no End of Line (EOL) termination set on the bus and that should be corrected at the EOL device.

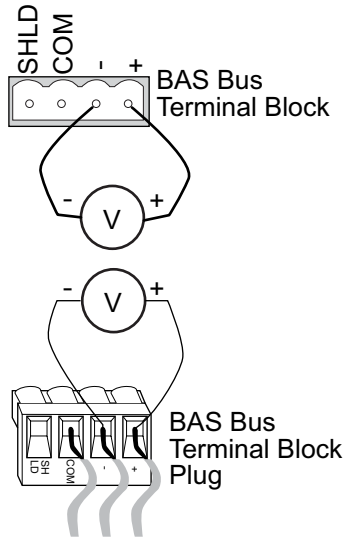

LD19997

**FIGURE 27 - BAS BUS METER CHECKS**

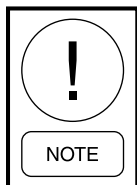

*The meter checks detailed for the BAS port can also be used for the CS and EQ ports.*

## FIRMWARE UPDATE

As new chiller data maps become available, it will be necessary to update the SC-EQ firmware. The following procedure should be followed to perform a firmware update.

- Copy the firmware update file on to an empty USB thumbdrive. The file will be named similar to: 1.0.0.0179.SCCUSB.pkg
- If the chiller is running, put it in to Local mode so that the SC-EQ will not affect chiller operation during the firmware update.
- Insert the USB thumbdrive in to the USB port J3 on the SC-EQ. The firmware update will start automatically and the Fault LED will flash quickly during the update process.
- When the firmware update is completed, the SC-EQ will reboot (All of the lights will go out then on again).
- Once the SC-EQ Fault LED is off for 30 seconds, the firmware upgrade is complete and the USB thumbdrive may be removed.

## REPAIR INFORMATION

There are no user replaceable parts in the SC-EQ. If the SC-EQ Comm Card fails to operate within its specifications, replace the unit. For a replacement SC-EQ Comm Card, contact the nearest Johnson Controls representative.

THIS PAGE INTENTIONALLY LEFT BLANK.

## SECTION 4 - SC-AP GATEWAY

### SC-AP OPTIVIEW MOUNTING

The SC-AP Installation Kit (p/n 331-03608-000) contains all of the materials needed to install the SC-AP into the OptiView chiller control panel using a DIN rail in new panels or velcro for older panels.

#### OptiView DIN Rail Panel Mount

1. New production panels have 3" piece of DIN rail installed to mount the SC-AP. The SC-AP installation kit contains two DIN rail end blocks to hold the SC-AP in place on the DIN rail.
2. Install one end block (p/n 025-29189-000) to the back end of the DIN rail, as shown in *Figure 28 on page 31*.
3. Pull the SC-AP case bottom mounting bracket clip outwards from the case.
4. Hang the SC-AP on the DIN rail and push the bottom mounting bracket clip upwards to secure the SC-AP to the DIN rail.
5. Install the second Din rail end block (p/n 025-29189-000) to the front end of the DIN rail, as shown in *Figure 29 on page 31*.

#### OptiView Velcro Panel Mount

1. On older panels that do not have a DIN rail mounted, the SC-AP should be mounted using the velcro parts of the Installation Kit.
2. Install the four round velcro fasteners (p/n 025-47586-000) to the four mounting holes on the back of the mounting bracket using four screws (p/n 021-34098-000), as shown in *Figure 30 on page 31*.
3. Stick one of the four square velcro pieces (p/n 025-47587-000) on to each of the four round velcro fasteners.
4. Remove the protective backing from the square velcro pieces, and carefully stick the SC-AP in the desired mounting location.



FIGURE 28 - DIN RAIL END BLOCK

LD20431



FIGURE 29 - SC-AP MOUNTED

LD20432

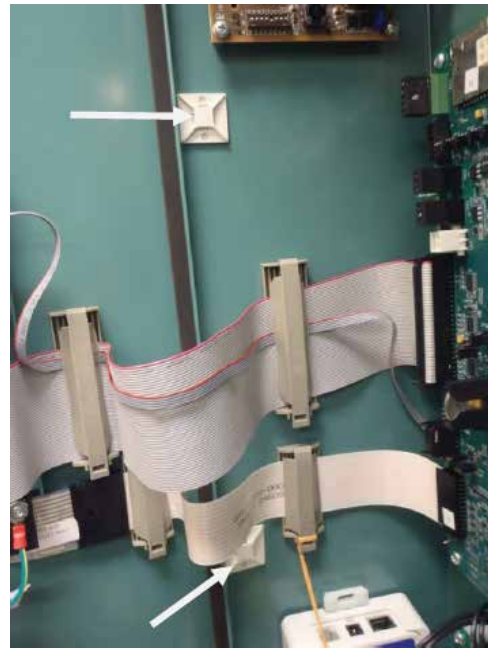

FIGURE 30 - SC-AP VELCRO PADS

LD20433

**DIN RAIL & Velco Panel Mount (Cont'd)**

5. Install one ty-wrap mount (p/n 025-25155-000) above the ribbon cables and one below to retain the coiled cable using two ty-wraps (p/n 025-18167-000), as shown in *Figure 32 on page 32*.
6. Install the coiled SC-AP cable by plugging one end into the SC-EQ CS RJ Port J1 and the other end into the SC-AP 6-pin RJ-12 connector. **Caution: Do not plug the SC-AP cable in to the SC-EQ BAS RJ jack as this will expose the wrong equipment to the SC-AP.**
7. Install the two ty-wraps in the ty-wrap mounts to hold the coiled cable, loosely tighten the ty-wrap and trim off the excess ty-wrap ends.
8. The installed SC-AP and SC-EQ should look similar to *Figure 33 on page 32*



LD20434

**FIGURE 32 - SC-AP CABLE TY-WRAPS**

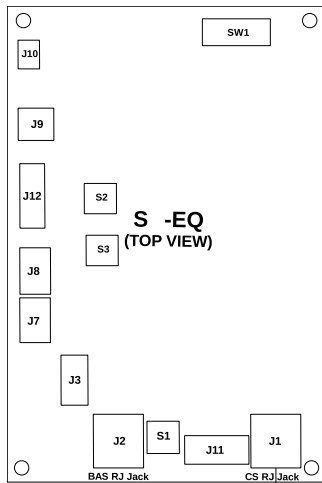

**NOTE: DO NOT CONNECT SC-AP TO BAS RJ JACK**

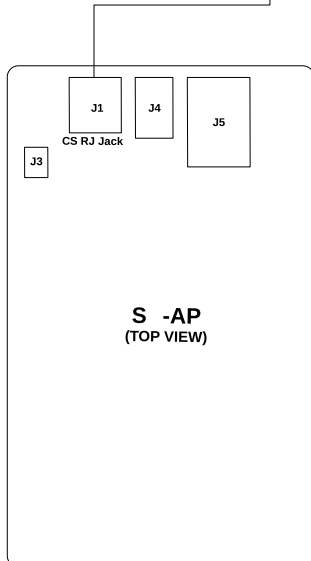

LD21043

**FIGURE 31 - SC-EQ TO SC-AP CABLE**



LD20435

**FIGURE 33 - SC-AP & SC-EQ INSTALLED**

## USING THE SC-AP FOR TROUBLESHOOTING

The SC-AP is a device that interfaces with Johnson Controls Connected Chillers service. This device can also be used to troubleshoot connectivity issues.

If an SC-AP is installed as part of a Connected Services installation, or if an SC-AP is available otherwise, connecting it to the SC-EQ allows the technician to view the port activity to aid in communication problem diagnosis. It is also required to manually set the Chiller Model on older YorkTalk2 chillers that do not auto-discover. Refer to page 34 for instructions on how to manually set the chiller model. For more detailed information on the SC-AP refer to *SC-AP Installation Instructions (Lit 24-10737-75)* and *SC-AP Quick Start (Lit 24-10737-75)*.

The first screen displayed on the SC-AP after login is the Device List screen, as shown in *Figure 34 on page 33*). The example shows two devices, the SC-AP, and the SC-EQ, as well as their MAC address. The SC-

AP will always be MAC address three. In the example below, the SC-EQ has MAC address four. The Device List can be used to help troubleshoot issues where the BAS is not connecting to the SC-EQ.

Selecting the SC-EQ Data tab will display the data for the SC-EQ. Four of the parameters in the SC-EQ Data tab display the three communication port settings and the Online/Offline status of the ports. Refer to *Figure 35 on page 33*.

The SC-EQ Port Status shows that the Equipment Port is communicating using YorkTalk 3 and the BAS is Modbus. The CS port is always BACnet MSTP. If either the BAS or the EQ port are not active for a short period of time, the status will be displayed as "Offline." If the communications is not present for a few minutes, the status will be displayed as "No Protocol." The SC-EQ will continually try to connect to the absent ports.

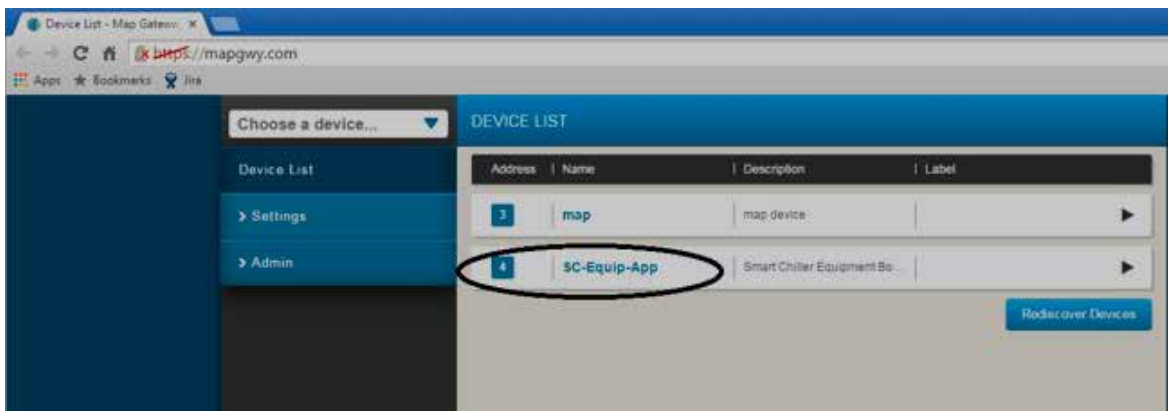

FIGURE 34 - SC-AP DEVICE LIST

LD19990



FIGURE 35 - SC-EQ PORT STATUS

LD19991a

### To Change the Device Instance

The SC-EQ will automatically create the Device Instance as 5000 plus the MAC Address switch setting. For example, if the MAC address DIP switches are set to a value of 6, the Device Instance will be 5006. Some customers require the Device Instance to be something other than the automatically generated 5000 series address. The SC-AP can be used to change the Device Instance to the customer desired address. Connect the SC-AP to the SC-EQ and log on to the SC-AP using a WiFi interface either from a Smartphone, a Laptop or Tablet PC. Refer to *SC-AP Installation (Lit 24-10737-75)* and *SC-AP Quick Start (Lit 24-10737-87)* for more information on the SC-AP.

\*Note that any MAP 4.0 device may be used to connect to the SC-EQ to change the Device Instance and to also look at the communication port status. It will not be able to communicate with the Cloud though. When you first click on a MAP 4.0 device, the Home page will load and display a "spinner" that never stops since it is looking to connect to a Simplicity SE or a RTU controller and can not find them. The user must just proceed to click on a menu item on the left-hand side to view information.

1. Select the SC-EQ Device then select the SC-EQ Data tab.



FIGURE 36 - SC-AP DEVICE LIST

A list of parameters will be shown on the right side of your WiFi Smartphone or PC screen.

2. Select the BACNET DEVICE INSTANCE MODE and change it from AUTO to MANUAL. Then select SAVE.



FIGURE 37 - DEVICE INSTANCE MODE

3. Next, select the SC-EQUIP BACNET INSTANCE ID and change it to the desired value. (Must be a number from 1 to 4914302).

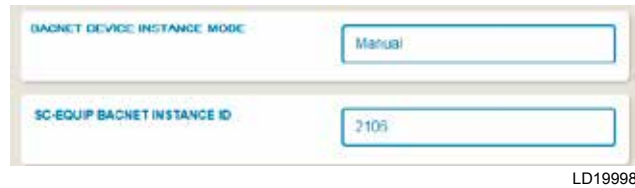

LD19998

### E-LINK REPLACEMENT

In BACnet autodiscovery, the E-Link transferred a list of all possible chiller parameters to the BAS. Even ones that did not apply. For example, if you had an Electro-Mechanical starter, the parameters for a VSD starter were shared by the E-Link and auto-discovered by the BAS. The SC-EQ discovers what type of chiller is connected and the chiller features and then exposes only the relevant points to the BAS. If an E-Link is replaced by an SC-EQ, the BAS will show the points that were non relevant previously as Offline. To resolve this you will either need to delete the E-Link and re-discover the SC-EQ or delete each of the inappropriate Offline points.

Offline		VSD PHASE A OUTPUT CURR... ??? 0.0 A
Offline		VSD PHASE B OUTPUT CURR... ??? 0.0 A
Offline		VSD PHASE C OUTPUT CURR... ??? 0.0 A
Offline		VSD COOLING SYS STAT ??? Off

LD19994

FIGURE 38 - INVALID POINTS OFFLINE

### BAS Commands

Points that are commandable will show as Unreliable until the BAS sends the setpoints.

Unreliable		REM LEAVING CHL TEMP SP ??? 0.0 deg F
Unreliable		REMOTE CURRENT SP ??? 0 %
Unreliable		REM RUN STOP CMD ??? Stop
		LEAVING CH LIQ TEMP 41.9 deg F
		ENTERING CH LIQ TEMP 58.3 deg F
		EVAPORATOR PRESSURE 39.2 psiG

LD19993

FIGURE 39 - UNRELIABLE REMOTE SETPOINTS

## MANUALLY SETTING THE CHILLER MODEL

Some of the older YorkTalk2 chillers do not have programming in place to tell the SC-EQ their chiller model. In these instances, a SC-AP will need to be used to tell the SC-EQ what chiller is present.

On the SC-AP SC-EQUIP DATA screen, when the Auto Detected Chiller Protocol is displayed as YorkTalk2

but the Auto Detected Chiller Model is NONE, an additional field is displayed named MANUALLY SELECTED CHILLER MODE. See *Figure 40 on page 35*. Clicking on this field allows the user to select the chiller model that the SC-EQ is connected to. See *Figure 41 on page 35*.

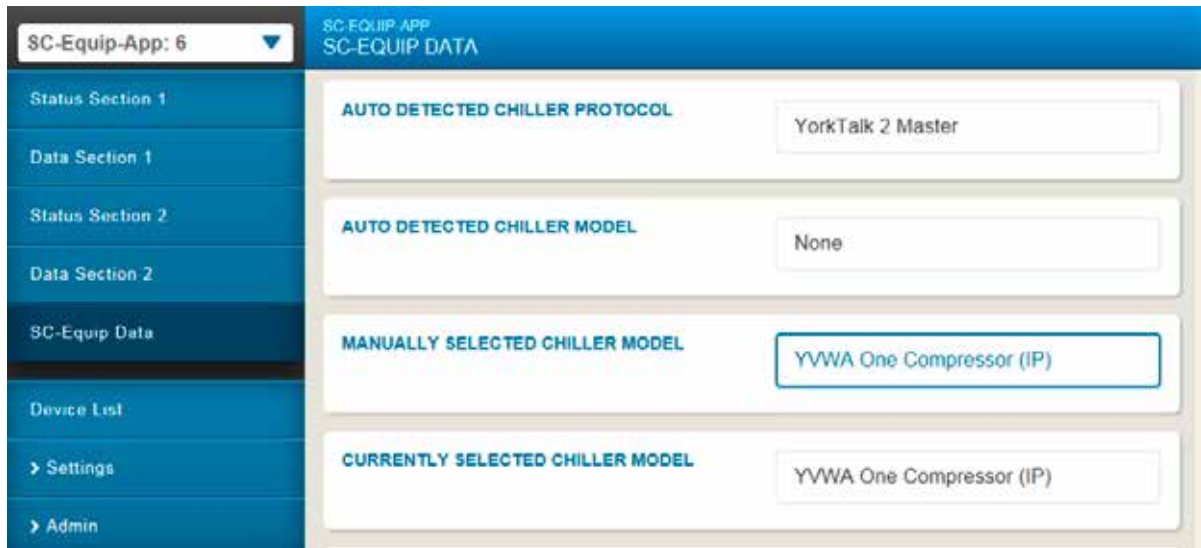

LD21041

FIGURE 40 - NO CHILLER MODEL TYPE DETECTED

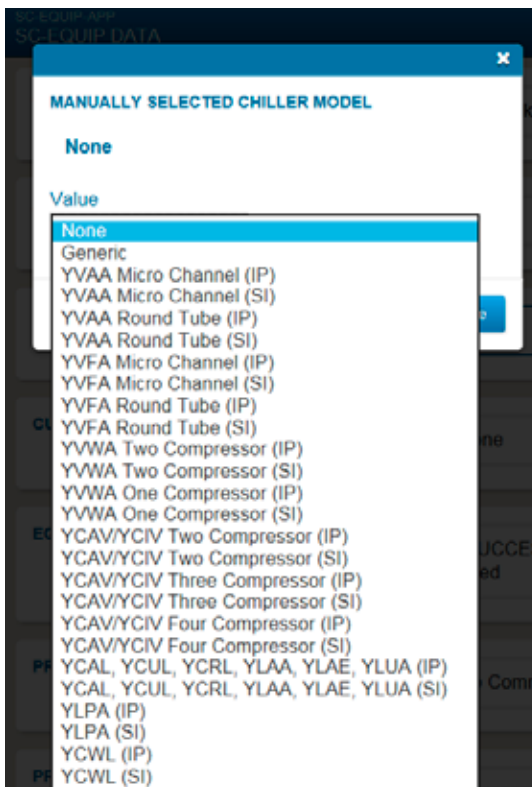

LD21042

FIGURE 41 - MANUALLY SELECTING CHILLER MODEL

THIS PAGE INTENTIONALLY LEFT BLANK.

## SECTION 5 - TECHNICAL SPECIFICATIONS

**TABLE 5 - TECHNICAL SPECIFICATIONS**

<b>Power Requirements</b>	<b>External to Equipment (Inside Enclosure):</b> 120/240 VAC Primary 50/60 Hz, 24 VAC Secondary Transformer (+10%/-15%), 400 mA, Nominal 12 VA <b>Internal to Equipment SC-EQ Comm Card Assembly:</b> 24 VAC (±15%), 50/60 Hz, 400 mA, Nominal 12 VA, 12 VDC (+50%/-2%), 400 mA, Nominal 12 VA	
<b>Addressing</b>	Addressing is selectable by the MAC Address Switch – 8 Position DIP Switch using Switches 1 through 7. <ul style="list-style-type: none"> <li>• BACnet MS/TP Addressing Range 1 to 127</li> <li>• Modbus RTU Addressing Range 1 to 127</li> <li>• N2 Addressing Range 1 to 127</li> </ul>	
<b>Installation Environment</b>	Protected, Dry	
<b>Ambient Operating Conditions</b>	Temperature: -40 to 65°C; (-40 to 149°F) Humidity: 0% to 95% Noncondensing	
<b>Ambient Storage Conditions</b>	Temperature: -40 to 85°C (-40 to 185°F) Humidity: 0 to 95% RH, Noncondensing	
<b>Power</b>	<b>External to Equipment (Inside Enclosure):</b> One 3-Position Terminal Block for 120/240 VAC Supply Power <b>Internal to Equipment SC-EQ Comm Card Assembly:</b> Removable Terminal Plug for 24 VAC Supply Power and Removable Terminal Plug for 12 VDC Supply Power	
<b>Communication Wiring Terminations</b>	<p>BAS Protocol is automatically detected          BAS Port J12: RS-485 BAS Port Supporting BACnet MS/TP, Modbus RTU and N2 Protocols With Available EOL Termination Switch</p> <p>Equipment Protocol and Model are automatically detected          EQ 485 Port J8: RS-485 Equipment Port Supporting BACnet MS/TP and YORK Talk II Protocols with Available EOL Termination Switch          EQ 232 Port J7: RS-232 Equipment Port Supporting YORK Talk 3 Protocol</p> <p>Connected Services          CS Port J11: RS-485 BAS Port Supporting BACnet MS/TP Protocol With Available EOL Termination Switch</p>	
<b>Wiring</b>	<b>Network Cable:</b> 0.51 mm (24 AWG) (3 Cores Plus Shield) <b>Power Cable:</b> 1.02 mm (18 AWG) Copper Wire Rated for 10 Amperes Per Core at 250 VAC	
<b>Materials</b>	<b>External to Equipment:</b> Metal Enclosure with Removable Lid, SC-EQ Comm Card Assembly, Power Transformer <b>Internal to Equipment E-Link Board Assembly:</b> SC-EQ Comm Card Assembly	
<b>Mounting</b>	<b>External to Equipment:</b> Screw Mount Enclosure <b>Internal to Equipment:</b> SC-EQ OptiView/Latitude and IPU-II installation kit	
<b>Dimensions</b>	<b>External to Equipment:</b> 241.3 x 136.5 x 63 mm (9-1/2 x 5-3/8 x 2-1/2 in.) <b>Internal to Equipment:</b> 102 x 152 x 25.4 mm (4 x 6 x 1 in.)	
<b>Shipping Weight</b>	<b>External to Equipment:</b> 2 kg (4.5 lb) <b>Internal to Equipment:</b> 227 g (8 oz)	
<b>Compliance</b>	<b>United States</b>	UL Listed 916/FCC Part 15 Conducted and Radiated
	<b>Europe</b>	CE Mark - Johnson Controls, Inc. declares that this product is in compliance with the essential requirements and other relevant provisions of the EMC Directive 2004/108/EC and Low Voltage Directive 2006/95/EC.

**NOTE:** The performance specifications are nominal and conform to acceptable industry standards. For application of conditions beyond these specifications, consult the local Johnson Controls office. Johnson Controls, Inc. shall not be liable for damages resulting from misapplication or misuse of its products.

## NOTES

**NOTE:** The information below can be shared with the technician responsible for the BAS network.

## INSTRUCTIONS FOR THE BAS CONTRACTOR

The SC-EQ Communication Card has the ability to automatically determine the BAS network protocol and communication parameters and set its communication parameters to match the installed BAS system.

If the chiller was already commissioned, there is no need for a chiller technician to return to the site to connect the BAS wiring and set the MAC address since these are standard tasks that a BAS contractor routinely performs.

The instructions on this page will assist you with these steps.

### BAS Wiring Connections

The BAS port J12 is the blue pluggable connector shown *below*. It is an RS-485 port with + - COM and SHLD marked. The SHLD (shield) terminal is not connected to any circuitry or ground and provides a convenient location to connect the shields of two daisy-chained segments. On some BAS systems the COM is called REF.

### Setting the MAC Address

The SC-EQ Communication Card Media Access Control (MAC) network hardware address is set on a single 8-way DIP switch. Switch 8 is not used. The switches are binary weighted allowing the setting of addresses from 1 to 127.

Once the DIP switches are set for the correct MAC address, cycle the power to the SC-EQ by momentarily unplugging the 24 VAC or +12 VDC power plug (depending upon how the SC-EQ is being powered). The SC-EQ Communication Card will then boot up and establish communications. This may take up to 120 seconds.

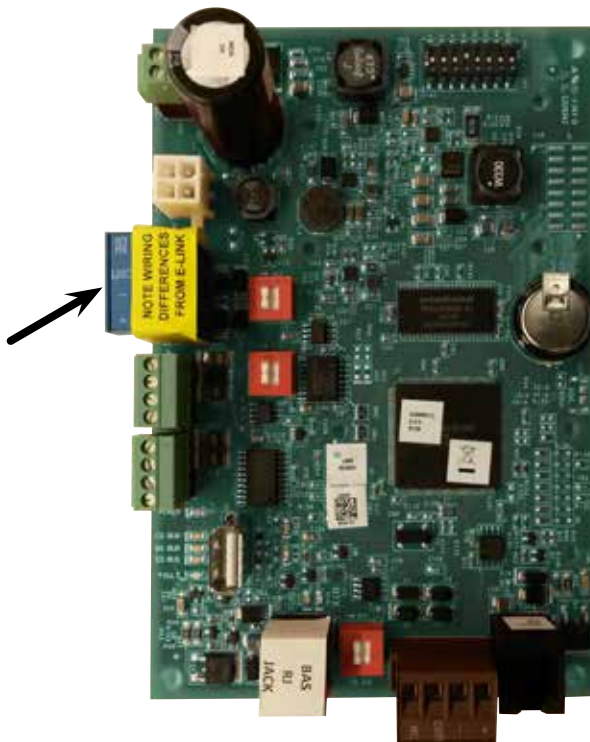



P.O. Box 1592, York, Pennsylvania USA 17405-1592  
Copyright © by Johnson Controls 2017  
Form 450.50-N1 (217)  
Issue Date: February 10, 2017  
Supersedes: 450.50-N1 (816)

800-861-1001  
[www.johnsoncontrols.com](http://www.johnsoncontrols.com)

Subject to change without notice. Printed in USA  
ALL RIGHTS RESERVED