



ELECTRONIC EXPANSION VALVE

INSTALLATION, OPERATION & MAINTENANCE

Supersedes: 050.40-NM4 (103)

Form 050.40-NM4 (403)

ELECTRONIC EXPANSION VALVE (EEV) FOR YCAL AND YCAS MODEL CHILLERS

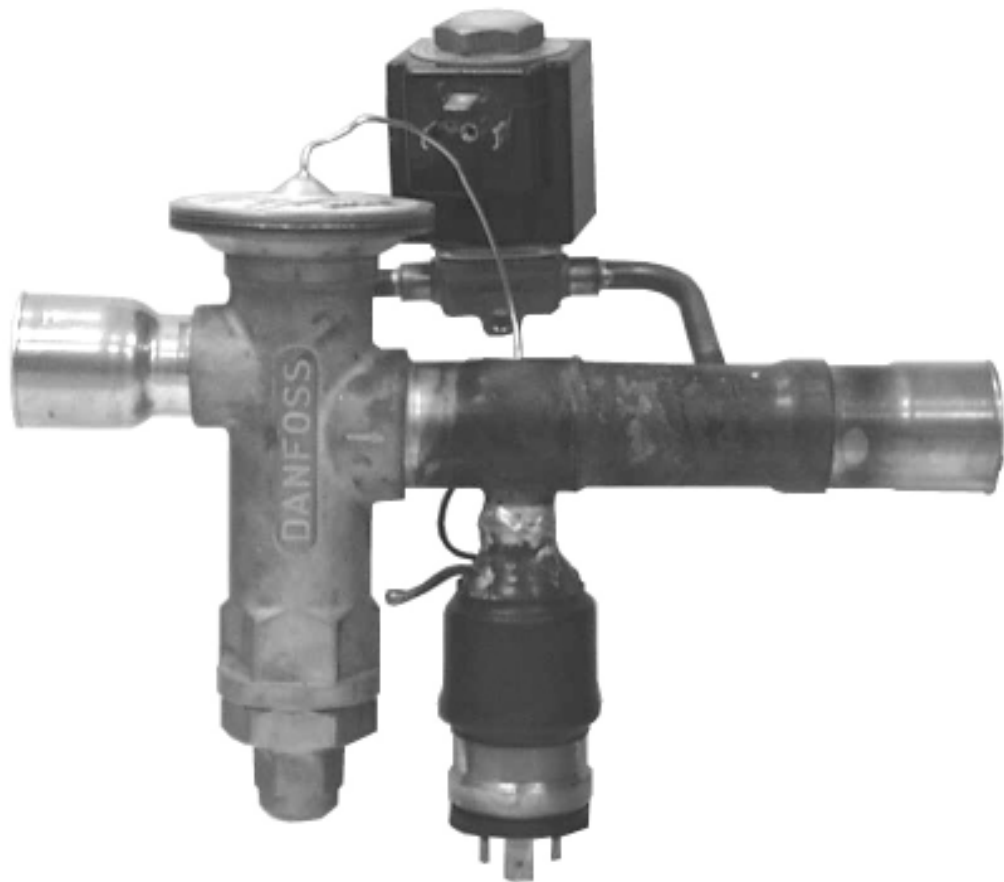

EEV1

50 AND 60
HERTZ



IMPORTANT!

READ BEFORE PROCEEDING!

GENERAL SAFETY GUIDELINES

This equipment is a relatively complicated apparatus. During installation, operation, maintenance or service, individuals may be exposed to certain components or conditions including, but not limited to: refrigerants, oils, materials under pressure, rotating components, and both high and low voltage. Each of these items has the potential, if misused or handled improperly, to cause bodily injury or death. It is the obligation and responsibility of operating/service personnel to identify and recognize these inherent hazards, protect themselves, and proceed safely in completing their tasks. Failure to comply with any of these requirements could result in serious damage to the equipment and the

property in which it is situated, as well as severe personal injury or death to themselves and people at the site.

This document is intended for use by owner-authorized operating/service personnel. It is expected that this individual possesses independent training that will enable them to perform their assigned tasks properly and safely. It is essential that, prior to performing any task on this equipment, this individual will have read and understood this document and any referenced materials. This individual will also be familiar with and comply with all applicable governmental standards and regulations pertaining to the task in question.

SAFETY SYMBOLS

The following symbols are used in this document to alert the reader to areas of potential hazard:



DANGER indicates an imminently hazardous situation which, if not avoided, will result in death or serious injury.



CAUTION identifies a hazard which could lead to damage to the machine, damage to other equipment and/or environmental pollution. Usually an instruction will be given, together with a brief explanation.



WARNING indicates a potentially hazardous situation which, if not avoided, could result in death or serious injury.

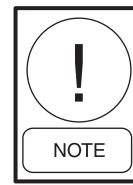

NOTE is used to highlight additional information which may be helpful to you.



External wiring, unless specified as an optional connection in the manufacturer's product line, is NOT to be connected inside the micro panel cabinet. Devices such as relays, switches, transducers and controls may NOT be installed inside the micro panel. NO external wiring is allowed to be run through the micro panel. All wiring must be in accordance with YORK's published specifications and must be performed ONLY by qualified YORK personnel. YORK will not be responsible for damages/problems resulting from improper connections to the controls or application of improper control signals. Failure to follow this will void the manufacturer's warranty and cause serious damage to property or injury to persons.



To protect warranty, this equipment must be serviced by an authorized YORK service mechanic or a qualified service person experienced in air handling and condenser unit maintenance.
Lethal voltages exist within the Control Panel. Before servicing, open and tag all disconnect switches.

TABLE OF CONTENTS

SECTION 1	INTRODUCTION	
	Electronic Expansion Valve	4
SECTION 2	INSTALLATION	
	Installation	5
	Installation Requirements	5
SECTION 3	OPERATION	
	Electronic Expansion Valve (EEV) Operation	6
	24VAC Heat Motor	6
	Controller	6
	MOP Feature	6
	Valve Preheat Feature	6
	Pilot Solenoid (LLSV) Control	7
	Low Superheat Cutout Safety	7
	Sensor Failure Cutout Safety	7
	Operating Data Displays (YCAL & YCAS)	8
	History Data Display (YCAL & YCAS)	8
	Operating Data Printout (YCAL & YCAS)	8
SECTION 4	PROGRAMMING	
	Expansion Valve Options Display (YCAL)	9
	Program Mode Display (YCAL)	9
	Expansion Valve Options Display (YCAS)	10
	Program Mode Display (YCAS)	10
SECTION 5	MAINTENANCE	
	Troubleshooting	11

LIST OF FIGURES

Fig. 1 – Electronic Expansion Valve	4	Fig. 5 – Programmable Values Table (YCAL)	9
Fig. 2 – Refrigerant Flow Direction	5	Fig. 5A – Programmable Values Table (YCAS) ...	10
Fig. 3 – EEV Insulation	5		

CHANGEABILITY OF THIS DOCUMENT

In complying with YORK's policy for continuous product improvement, the information contained in this document is subject to change without notice. While YORK makes no commitment to update or provide current information automatically to the manual owner, that information, if applicable, can be obtained by contacting the nearest YORK Applied Systems Service office.

It is the responsibility of operating/service personnel to verify the applicability of these documents to the equipment in question. If there is any question in the mind of operating/service personnel as to the applicability of these documents, then prior to working on the equipment, they should verify with the owner whether the equipment has been modified and if current literature is available.

ELECTRONIC EXPANSION VALVE

ELECTRONIC EXPANSION VALVE

The Electronic Expansion Valve (EEV) is an electronically controlled expansion valve. The control algorithms to control the EEV reside in the micro-processor software. The superheat setpoint can be programmed on the control panel.

The purpose of the EEV is to meter a flow of liquid refrigerant into the evaporator to maintain a

superheat setpoint. The refrigerant flow direction is designated by an arrow on the expansion valve body.

There are two safeties associated with the EEV, Low Superheat Cutout and Sensor Failure Cut-out.

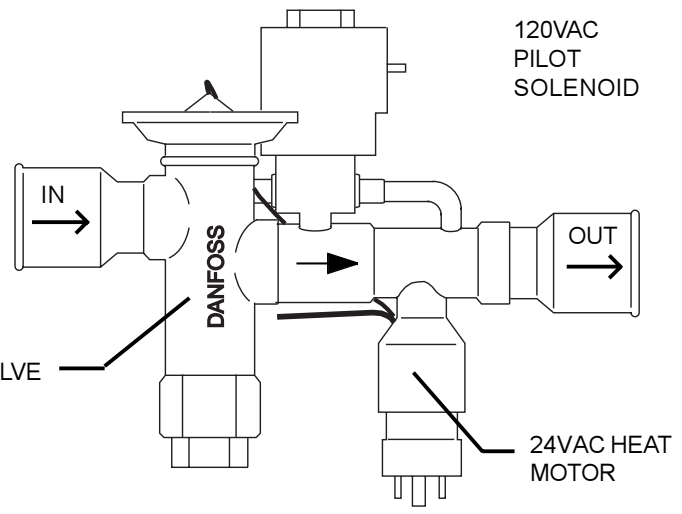
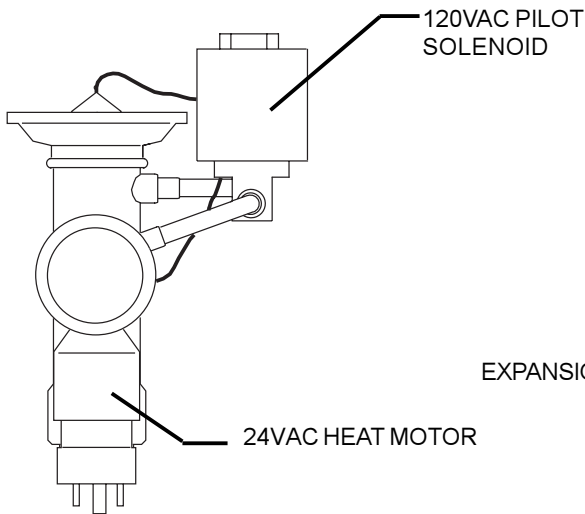
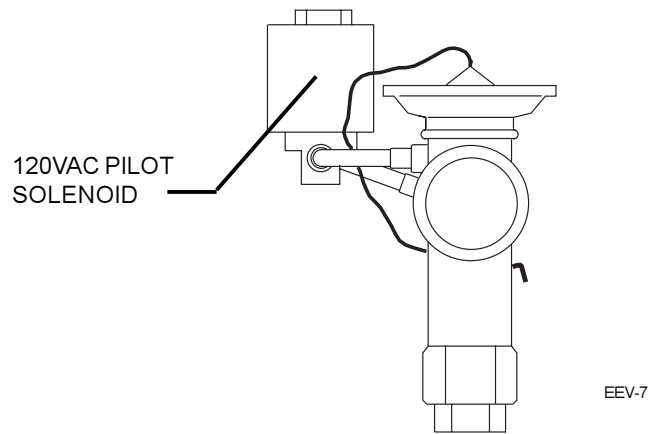
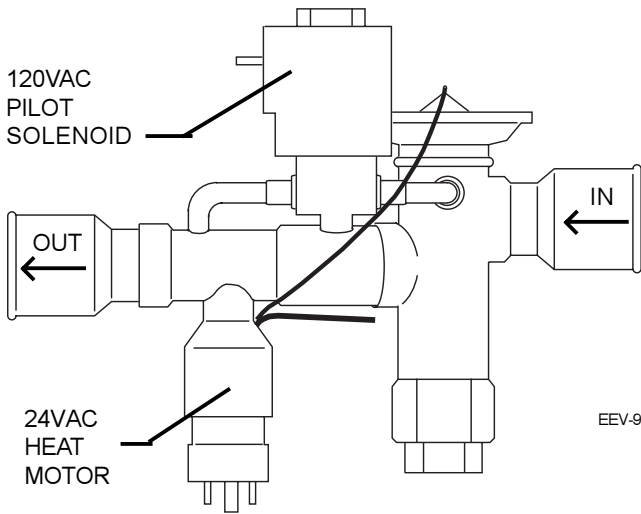

FIG. 1 – ELECTRONIC EXPANSION VALVE

INSTALLATION



To protect warranty, this equipment must be installed by an authorized YORK service mechanic or a qualified service person experienced in air handling and condenser unit installation. Installation must comply with all applicable codes, particularly in regard to electrical wiring and other safety elements such as relief valves, HP cut-out settings, design working pressures and ventilation requirements consistent with the amount and type of refrigerant charge.

Lethal voltages exist within the Control Panel. Before servicing, open and tag all disconnect switches.

INSTALLATION

The Electronic Expansion Valve is typically factory installed as part of the standard product or as an option, but should a field installation be needed see the following instructions.

1. Arrow on valve indicates flow direction.
2. Pump down the refrigerant system by closing the liquid stop valve. Run the compressor until suction pressure drops to a value slightly above 0 PSIG. Close the suction and discharge the stop valves (if installed).
3. Pump out the remaining refrigerant in the liquid lines using acceptable industry methods for refrigerant removal and storage.

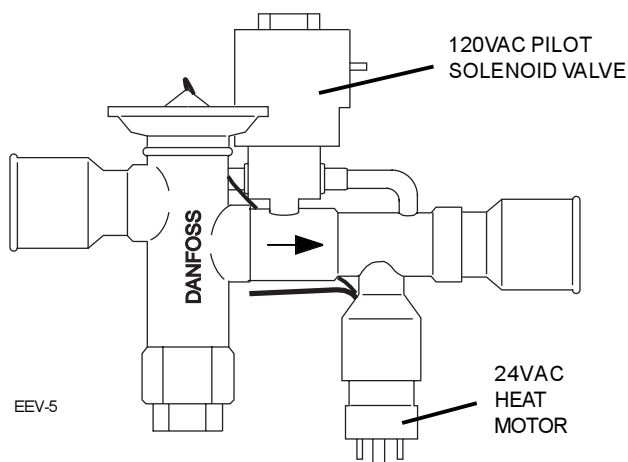

FIG. 2 – REFRIGERANT FLOW DIRECTION

4. Cut out the old valve.
5. Braze in the new valve using a nitrogen purge.
6. Evacuate the piping to 500 microns.
7. Break the vacuum and recharge the system.



The Pilot Solenoid Valve and Heat Motor plugs are identical. DO NOT reverse the plugs or serious damage will occur to the EEV.

When insulating the piping for the EEV, be sure to also insulate the heat motor to ensure proper operation. See Fig. 4

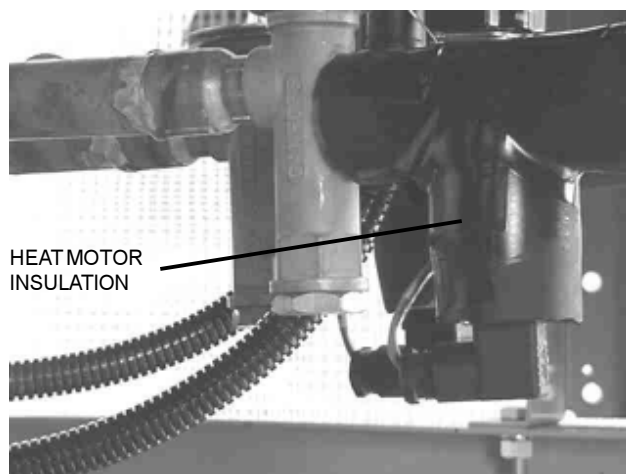

FIG. 3 – EEV INSULATION

I/O REQUIREMENTS

The following sensors are required for EEV control.

- Suction Pressure Transducer
- Suction Temp Sensor

The following outputs are required for EEV control.

- EEV Pilot Solenoid Valve (LLSV)
- EEV Heat Motor Output

OPERATION

EEV OPERATION

The EEV is an electronically controlled expansion valve that meters a flow of liquid refrigerant into the evaporator to control superheat. The refrigerant flow direction is designated by an arrow on the expansion valve body.

24VAC HEAT MOTOR

The 24VAC Heat Motor is fed from the EEV output board in the control panel. The Heat Motor allows the micro to open and close the valve to control suction superheat.



The heat motor must be plugged into the 24 volt shielded cable feed from the EEV output board. Damage to the heat motor will occur if it is plugged into 120VAC wiring for the Pilot Solenoid.

CONTROLLER

When EEV is selected as the expansion valve type under Service Mode for YCAL or via DIP switch for YCAS, the EEV controller will become active. When TXV is selected, the EEV output will be fixed at 0 and the low superheat and sensor failure safeties will be disabled.

The EEV controller is a PI (Proportional plus Integral) controller. Gain scheduling varies the proportional gain based on the superheat error. As the superheat error gets smaller the proportional gain will get smaller. The integration time is adjusted to increase the controller response during start-up and low superheat conditions.

The output from the PI controller is the EEV output percentage which is shown on the display and printouts. This output is then fed into a model of the ETRE bulb/heat motor to over and under drive the heat motor for faster valve response. The output of this ETRE model is the PWM percentage that will be sent to the ETRE heat motor. This PWM output is the percentage of a 1 second period that the 24VAC heat motor power signal is energized.

MOP FEATURE

The controller also has an MOP feature (Maximum Operating Pressure) that overrides superheat control when the MOP setpoint is exceeded. This control generally will be active for hot water starts. The MOP setpoint is 60° F Saturated Suction Temperature.

The MOP feature is also used to prevent undershoot of the superheat setpoint when the suction temperature of a system being started is much higher than the return water temperature. This provides better startup superheat control for high ambient, low water temp startups when the superheat measurement is artificially high due to the warm suction line. If the return water temp sensor is in range, run time is less than 5 minutes, and suction temperature is greater than $(RCHLT + 3^{\circ} F)$, the MOP setpoint is reset to $RCHLT - \text{Superheat Setpoint}$. If this value is higher than the fixed MOP setpoint, the original setpoint is retained.

VALVE PREHEAT FEATURE

The heat motor is preheated for moderate and low ambient standby conditions. When the ambient is below 25° F, the heat motor is preheated with a 25% duty cycle. This preheated value is ramped from 25% to 0% from 25° F to 50° F. When the ambient is above 50° F the heat motor is not preheated.

OPERATION - CONT'D

PILOT SOLENOID (LLSV) CONTROL

The Pilot Solenoid allows the EEV to be used in the same way as a Liquid Line Solenoid Valve. When the Pilot Solenoid is turned off, the EEV closes immediately and prevents the Heat Motor from opening the valve.

Each system has a Pump Down feature upon shut off. Manual pump down from the keypad is not possible. On a non-safety, non-unit switch shutdown, the system will fully unload. The Pilot Solenoid will be turned off and the system will run unloaded until the suction pressure falls below the cutout or for 180 seconds, whichever comes first.

The Pilot Solenoid is also used as a low superheat safety device when EEV is selected as the expansion valve type, for YCAL units only. While the system is running and not in a pumpdown mode the Pilot Solenoid will close if the suction superheat falls below 4.0° F. The Pilot Solenoid will open again when the superheat rises above 7.0° F. This safety device is ignored for the first 30 seconds of system run time. If the Pilot Solenoid is closed 10 times in 2 minutes on the safety device, the low superheat safety will be triggered.

LOW SUPERHEAT CUTOUT SAFETY

The Low Superheat Cutout is to protect the compressors from liquid floodback due to low suction superheat. This safety is only active when EEV is selected as the expansion valve type. This safety is ignored for the first 15 seconds of system run time.

This safety can be triggered by two events. The first is when the suction superheat is less than 2.0° F for 3 seconds. The second, only applies to YCAL units, is when the Pilot Solenoid is closed 10 times in 2 minutes due to low superheat. Following are the safety fault messages for all systems:

SYS 1	LOW SUPERHEAT
SYS 2	LOW SUPERHEAT

SENSOR FAILURE CUTOUT SAFETY

The Sensor Failure Cutout is to prevent the EEV from running when the sensors measuring superheat are not functioning properly. This safety is only active when EEV is selected as the expansion valve type. This safety is ignored for the first 15 seconds of system run time.

This safety will shutdown a system if either suction temperature or suction pressure sensors read out of range high or low. This condition must be present for 3 seconds to cause a system shutdown. This safety will lock out a system the first time and will not allow automatic restarting. Following are the messages for all systems:

SYS 1	SENSOR FAILURE
SYS 2	SENSOR FAILURE

OPERATING DATA

OPERATING DATA DISPLAYS (YCAL)

The following displays relating to EEV operation are available under the Oper Data Key: Suction Pressure, Suction Temp, Saturated Suction Temp, Suction Superheat, EEV Output% and Pilot Solenoid (LLSV) Output State. Saturated Suction Temp, Suction Superheat, EEV Output% will only be displayed if EEV is selected as the expansion valve type.

SYS X SUCT = XXX.X°F
SAT SUCT = XXX.X°F

SYS X EEV = XXX.X %
SUCT SHEAT = XXX.X°F

HISTORY DATA DISPLAYS (YCAL)

Under the history key, Suction Temp, Saturated Suction Temp, EEV Output, and Suction Superheat will only be displayed if EEV is selected as the expansion valve type.

SYS X SUCT = XXX.X°F
SAT SUCT = XXX.X°F

SYS X EEV = XXX.X %
SUCT SHEAT = XXX.X°F

OPERATING DATA PRINTOUT (YCAL)

Pressing the PRINT key and then the OPER DATA key allows the operator to obtain a printout of current system operating parameters. When the OPER DATA key is pressed, a snapshot will be taken of system operating conditions and panel programming selections. This data will be temporarily stored in memory and transmission of this data will begin to the printer. The following items are added to the standard operational data printout when EEV is selected:

SYSTEM DATA			
SUCTION TEMPERATURE	52.8	DEGF	
SAT SUCTION TEMP	40.8	DEGF	
SUCTION SUPERHEAT	12.0	DEGF	
EEV OUTPUT			0.0%

OPERATING DATA DISPLAYS (YCAS)

The following display relating to EEV operation is available under each systems Data Key: EEV Output% and Suction Superheat.

SYS X EEV = XXX.X %
SUCT SHEAT = XXX.X°F

HISTORY DATA DISPLAYS (YCAS)

The following display relating to EEV operation is available under each systems Data Key: EEV Output% and Suction Superheat.

SYS X EEV = XXX.X %
SUCT SHEAT = XXX.X°F

OPERATING DATA PRINTOUT (YCAS)

Pressing the PRINT key and then the OPER DATA key allows the operator to obtain a printout of current system operating parameters. When the OPER DATA key is pressed, a snapshot will be taken of system operating conditions and panel programming selections. This data will be temporarily stored in memory and transmission of this data will begin to the printer. The following items are added to the standard operational data printout when EEV is selected:

SYSTEM DATA	
EEV OUTPUT	0.0%

PROGRAMMING (YCAL)

EXPANSION VALVE OPTIONS DISPLAY

When the expansion valve type is set to thermostatic under Service Mode, the EEV controller, low superheat safety device, low superheat safety and the sensor failure safety will be disabled. The EEV output will be set to 0.

EXPANSION VALVE TYPE
THERMOSTATIC

When the expansion valve type is set to electronic under Service Mode, the EEV controller, low superheat safety device, low superheat safety and the sensor failure safety will be enabled.

EXPANSION VALVE TYPE
ELECTRONIC

The Expansion Valve type selection is only viewable under the OPTIONS key.

PROGRAM MODE DISPLAYS

The following values are programmable under the PROGRAM key (See Fig. 6).

- System 1 Suction Superheat Setpoint (10.0°F to 15.0°F)
- System 2 Suction Superheat Setpoint (10.0°F to 15.0°F)

SYS 1 SUCT SUPERHEAT
SETPOINT = XX.X °F

SYS 2 SUCT SUPERHEAT
SETPOINT = XX.X °F

FIG. 5 – PROGRAMMABLE VALUES TABLE (MINIMUM/MAXIMUM)

PROGRAM VALUE	MODE	LOW LIMIT	HIGH LIMIT	DEFAULT
SYSTEM 1 SUPERHEAT SETPOINT	EEV	10.0°F 5.5°C	15.0°F 8.3°C	12.0°F 6.6°C
SYSTEM 2 SUPERHEAT SETPOINT	EEV	10.0°F 5.5°C	15.0°F 8.3°C	12.0°F 6.6°C

PROGRAMMING (YCAS)

EXPANSION VALVE OPTIONS DISPLAY

When the expansion valve type is set to thermostatic by opening DIP switch #7, the EEV controller, low superheat safety device, low superheat safety and the sensor failure safety will be disabled. The EEV output will be set to 0.

S1-7 EXPANSION VALVE
THERMOSTATIC

When the expansion valve type is set to electronic by closing DIP switch #9, the EEV controller, low superheat safety device, low superheat safety and the sensor failure safety will be enabled.

S1-7 EXPANSION VALVE
THERMOSTATIC

The Expansion Valve type selection is viewable under the OPTIONS key.

PROGRAM MODE DISPLAYS

The following values are programmable under the PROGRAM key (See Fig. 6).

- System 1 Suction Superheat Setpoint (9.0°F to 15.0°F)
- System 2 Suction Superheat Setpoint (9.0°F to 15.0°F)

SYS 1 SUCT SUPERHEAT
SETPOINT = XX.X °F

SYS 2 SUCT SUPERHEAT
SETPOINT = XX.X °F

FIG. 5A – PROGRAMMABLE VALUES TABLE (MINIMUM/MAXIMUM)

PROGRAM VALUE	MODE	LOW LIMIT	HIGH LIMIT	DEFAULT
SYSTEM 1 SUPERHEAT SETPOINT	EEV	9.0°F 5.0°C	15.0°F 8.3°C	12.0°F 6.6°C
SYSTEM 2 SUPERHEAT SETPOINT	EEV	9.0°F 5.0°C	15.0°F 8.3°C	12.0°F 6.6°C

TROUBLESHOOTING

TROUBLESHOOTING

Following are some problems and possible solutions or items to check.

o The system shuts down on Low Suction Pressure

- Verify that all refrigerant valves are open.
- Verify that the system is not low on charge.
- Verify that the Expansion Valve Type is set to Electronic.
- Verify that the pilot solenoid is energizing (use Service Mode to manually energize the solenoid coil).
- Verify that the EEV is wired per the elementary diagram.
- Verify that the Heat Motor is getting a 24VAC PWM signal. (Use Service Mode to manually energize the EEV output.
- If everything checks out, it is possible that the EEV has failed. If the small charge in the bulb leaks, the valve will not be able to open and the entire EEV must be replaced.

o The system shuts down on Low Superheat

- Verify that the suction temperature sensors are properly installed. They should be located at 4 or 8 o'clock on the suction line. They should not be located near the outlet of the cooler. They should be installed with copper straps and be well insulated.
- Verify that the suction temperature sensor cables are not swapped between systems (unplugging one sensor at a time with the chiller off can verify proper wiring).
- Verify that the EEV heat motor is properly insulated.
- For units with Hot Gas Bypass installed, check that the Hot Gas Bypass value is set correctly.
- For glycol units, verify that the glycol % is correct.

