



AIR-COOLED LIQUID CHILLERS HERMETIC SCROLL

INSTALLATION, OPERATION, MAINTENANCE

New Release

Form 150.62-NM4 (502)

YCAL0014E_ - YCAL0124E_ R-22 & HFC-407C STYLE B (60 Hz)



29224(R)A

YCAL0014 – YCAL0080 EPROM (031-02050-001 MICROBOARD)



YCAL0090 – YCAL0124 EPROM



Metric Conversions



200-3-60
230-3-60
380-3-60
460-3-60
575-3-60
MODELS ONLY

Standard, Glycol & Metric Models, Combined

IMPORTANT!

READ BEFORE PROCEEDING!

GENERAL SAFETY GUIDELINES

This equipment is a relatively complicated apparatus. During installation, operation, maintenance or service, individuals may be exposed to certain components or conditions including, but not limited to: refrigerants, oils, materials under pressure, rotating components, and both high and low voltage. Each of these items has the potential, if misused or handled improperly, to cause bodily injury or death. It is the obligation and responsibility of operating/service personnel to identify and recognize these inherent hazards, protect themselves, and proceed safely in completing their tasks. Failure to comply with any of these requirements could result in serious damage to the equipment and the property in which it is situated, as well as severe personal injury or death to themselves and people at the site.

This document is intended for use by owner-authorized operating/service personnel. It is expected that this individual possesses independent training that will enable them to perform their assigned tasks properly and safely. It is essential that, prior to performing any task on this equipment, this individual shall have read and understood this document and any referenced materials. This individual shall also be familiar with and comply with all applicable governmental standards and regulations pertaining to the task in question.

SAFETY SYMBOLS

The following symbols are used in this document to alert the reader to areas of potential hazard:



DANGER indicates an imminently hazardous situation which, if not avoided, will result in death or serious injury.



WARNING indicates a potentially hazardous situation which, if not avoided, could result in death or serious injury.



CAUTION identifies a hazard which could lead to damage to the machine, damage to other equipment and/or environmental pollution. Usually an instruction will be given, together with a brief explanation.

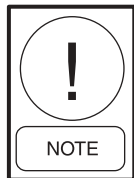

NOTE is used to highlight additional information which may be helpful to you.

CHANGEABILITY OF THIS DOCUMENT

In complying with YORK's policy for continuous product improvement, the information contained in this document is subject to change without notice. While YORK makes no commitment to update or provide current information automatically to the manual owner, that information, if applicable, can be obtained by contacting the nearest YORK Engineered Systems Service office.

It is the responsibility of operating/service personnel to verify the applicability of these documents to the equipment in question. If there is any question in the mind of operating/service personnel as to the applicability of these documents, then prior to working on the equipment, they should verify with the owner whether the equipment has been modified and if current literature is available.

TABLE OF CONTENTS AND LIST OF TABLES

	<u>PAGE</u>
PRODUCT IDENTIFICATION NUMBER	7-8
REFRIGERANT FLOW DIAGRAM	9
SECTION 1 INSTALLATION	10
ELECTRICAL DATA	20
OPERATIONAL LIMITATIONS	30
PHYSICAL DATA	34
DIMENSIONS & CLEARANCES	38
PRE-STARTUP CHECKLIST	66
INITIAL STARTUP	67
UNIT OPERATING SEQUENCE	69
SECTION 2 UNIT CONTROLS	70
STATUS KEY	72
DISPLAY/PRINT KEYS	78
ENTRY KEYS	88
SETPOINTS KEYS	89
UNIT KEYS	96
UNIT OPERATION	101
SECTION 3 SERVICE AND TROUBLESHOOTING	115
SERVICE MODE – CHILLER CONFIGURATION	116
OPTIONAL PRINTER INSTALLATION	124
TROUBLESHOOTING CHARTS	125
MAINTENANCE	128
ISN CONTROL	129
SECTION 4 WIRING DIAGRAMS	132
SECTION 5 APPENDIX 1 – ISOLATORS	162
YORK APPLIED SYSTEMS FIELD OFFICE LISTING	156

TABLES

1 MICRO PANEL POWER SUPPLY	20
2 STANDARD SINGLE-POINT POWER (YCAL0014E_ - YCAL0034E_) ...	21
3 STANDARD DUAL POINT POWER (YCAL0040E_ - YCAL0080E_) ..	22 – 23
4 SINGLE-POINT POWER SUPPLY CONNECTIONS (YCAL0040E_ - YCAL0080E_)	24 – 25
5 MULTIPLE POINT POWER SUPPLY CONNECTIONS (YCAL0090E_ - YCAL0124E_)	26 – 27
6 SINGLE-POINT POWER SUPPLY CONNECTIONS W/ INDIVIDUAL CIRCUIT BREAKERS (YCAL0090E_ - YCAL0124E_)	28 – 29
7 TEMPERATURES AND FLOWS (ENGLISH)	30
8 VOLTAGE LIMITATIONS	30
9 COOLER PRESSURE DROP CURVES (ENGLISH)	31

LIST OF TABLES

TABLES	PAGE
10 ETHYLENE GLYCOL CORRECTION FACTORS	31
11 TEMPERATURES AND FLOWS (METRIC)	32
12 VOLTAGE LIMITATIONS (METRIC)	32
13 COOLER PRESSUER DROP CURVES (METRIC)	33
14 ETHYLENE GLYCOL CORRECTION FACTORS	33
15 PHYSICAL DATA (ENGLISH)	34 – 35
16 PHYSICAL DATA (METRIC)	36 – 37
17 SETPOINTS ENTRY LIST	67
18 STATUS KEY MESSAGES	77
19 OPERATOR DATA QUICK REFERENCE LIST	82
20 COOLING SETPOINTS, PROGRAMMABLE LIMITS & DEFAULTS	91
21 PROGRAM KEY LIMITS & DEFAULTS	94
22 SETPOINTS KEY QUICK REFERENCE LIST	95
23 UNIT KEYS QUICK REFERENCE LIST	100
24 COMPRESSOR STAGING FOR RETURN WATER CONTROL	103
25 LEAVING CHILLED LIQUID CONTROL – 5 & 6 COMPRESSORS	103
26 LEAVING CHILLED LIQUID CONTROL – 4 COMPRESSORS	104
27 YCAL0014 - YCAL0080 CONDENSER FAN CONTROL USING OUTDOOR AMBIENT TEMP. & DP	107
28 YCAL0014 - YCAL0080 CONDENSER FAN CONTROL USING DP ONLY	107
29 YCAL0014 - YCAL0080 LOW AMBIENT CONDENSER FAN CONTROL	108
30 YCAL0014 - YCAL0080 LOW AMBIENT CONDENSER FAN CONTROL + DISCHARGE PRESSURE CONTROL	108
31 YCAL0090 - YCAL0094 CONDENSER FAN CONTROL	109
32 YCAL0114 - YCAL0124 CONDENSER FAN CONTROL	110
33 COMPRESSOR OPERATION – LOAD LIMITING	112
34 MICROBOARD DIGITAL INPUTS	117
35 MICROBOARD ANALOG INPUTS	117
36 MICROBOARD DIGITAL OUTPUTS	117
37 MICROBOARD ANALOG OUTPUTS	117
38 OUTDOOR AIR SENSOR TEMP./VOLT./RESISTANCE	119
39 ENTERING & LEAVING CHILLED LIQUID TEMPERATURE SENSOR, COOLER INLET TEMP. & SUCTION TEMP.	120
40 KEYPAD PIN ASSIGNMENT MATRIX	123
41 TROUBLESHOOTING CHARTS	125
42 ISN RECEIVED DATA	129
43 ISN TRANSMITTED DATA	129
44 ISN OPERATIONAL & FAULT CODES	131

LIST OF FIGURES

1	REFRIGERANT FLOW DIAGRAM	9
2	SINGLE-POINT SUPPLY CONNECTION	14
3	MULTIPLE POINT POWER SUPPLY CONNECTION	15
4	MULTIPLE POINT POWER SUPPLY WIRING – TERMINAL BLOCK, NON-FUSED DISCONNECT SWITCH OR CIRCUIT BREAKER	16
5	OPTIONAL SINGLE-POINT WIRING	17
6	CONTROL WIRING	18
7	SETPOINT ADJUST	102
8	LEAVING WATER TEMPERATURE CONTROL – EXAMPLE	102
9	YCAL0014 - YCAL0080 FAN LOCATION (TYPICAL)	107
10	YCAL0090 - YCAL0094 FAN LOCATION	109
11	YCAL0114 - YCAL0124 FAN LOCATION	110
12	FIELD & FACTORY ELECTRICAL CONNECTIONS – OPTIONAL REMOTE TEMPERATURE RESET BOARD	114
13	MICROBOARD LAYOUT	118
14	MICROBOARD RELAY CONTACT ARCHITECTURE	122
15	PRINTER TO MICROBOARD ELECTRICAL CONNECTIONS	124
16	ELEMENTARY DIAGRAM – CONTROL CIRCUIT (YCAL0014E_ - YCAL0020E_) ...	132 - 133
17	ELEMENTARY DIAGRAM – POWER CIRCUIT (YCAL0014E_ - YCAL0020E_)	134
18	ELEMENTARY DIAGRAM – CONTROL CIRCUIT (YCAL0040E_ - YCAL0060E_) ...	136 - 137
19	ELEMENTARY DIAGRAM – POWER CIRCUIT (YCAL0040E_ - YCAL0060E_)	138
20	ELEMENTARY DIAGRAM – CONTROL CIRCUIT (YCAL0064E_ - YCAL0080E_) ...	140 - 141
21	ELEMENTARY DIAGRAM – POWER CIRCUIT (YCAL0064E_ - YCAL0080E_)	142
22	ELEMENTARY DIAGRAM – CONTROL CIRCUIT (YCAL0090E_ - YCAL0094E_) ...	144 - 145
23	ELEMENTARY DIAGRAM – POWER CIRCUIT (YCAL0090E_ - YCAL0094E_) ...	145B - 146
24	ELEMENTARY DIAGRAM, DETAIL A & B (YCAL0090E_ - YCAL0094E_)	147
25	CONNECTION DIAGRAM (YCAL0090E_ - YCAL0094E_)	148 - 149
26	ELEMENTARY DIAGRAM – CONTROL CIRCUIT (YCAL0104E_)	150 - 151
27	ELEMENTARY DIAGRAM – POWER CIRCUIT (YCAL0104E_)	151B - 152
28	ELEMENTARY DIAGRAM, DETAIL A & B (YCAL0104E_)	153
29	CONNECTION DIAGRAM (YCAL0104E_)	154
30	ELEMENTARY DIAGRAM – CONTROL CIRCUIT (YCAL0114E_ - YCAL0124E_)	156 - 157
31	ELEMENTARY DIAGRAM – POWER CIRCUIT (YCAL0114E_ - YCAL0124E_)	157B - 158
32	ELEMENTARY DIAGRAM, DETAIL A & B (YCAL0114E_ - YCAL0124E_)	159
33	CONNECTION DIAGRAM (YCAL0114E_ - YCAL0124E_)	160 - 161
34	ISOLATORS, TYPE CP 1	164
35	ISOLATORS, TYPE CP 2	164
36	R SPRING SEISMIC ISOLATOR	165
37	TYPE CP MOUNTING	166
38	“AEQM” SPRING-FLEX MOUNTING	167

PRODUCT IDENTIFICATION NUMBER (PIN)

BASIC MODEL NUMBER

YCAL0080E _ 46XBA

1	2	3	4	5	6	7	8	9	10	11	12	13	14	15			
BASE PRODUCT TYPE				NOMINAL CAPACITY				UNIT DESIGNATOR	REFRIGERANT	VOLTAGE/STARTER			DESIGN/DEVELOPMENT LEVEL				
Y	C	A	U	0	1	#	#	#	E	C	1	7	B	A			
: YORK : Chiller : Air-Cooled : Condensing Unit L : Scroll				# # # # # # Even Number: 60 HZ Nominal Tons Odd Number: 50 HZ Nominal kW				E : High Efficiency			C : R-22 B : R-407C			: 200 / 3 / 60 : 230 / 3 / 60 : 380 / 3 / 60 : 460 / 3 / 60 : 380-415 / 3 / 50 : 575 / 3 / 60 X : Across the Line		: Design Series A A : Engineering Change or PIN Level	

REFRIGERANT FLOW DIAGRAM

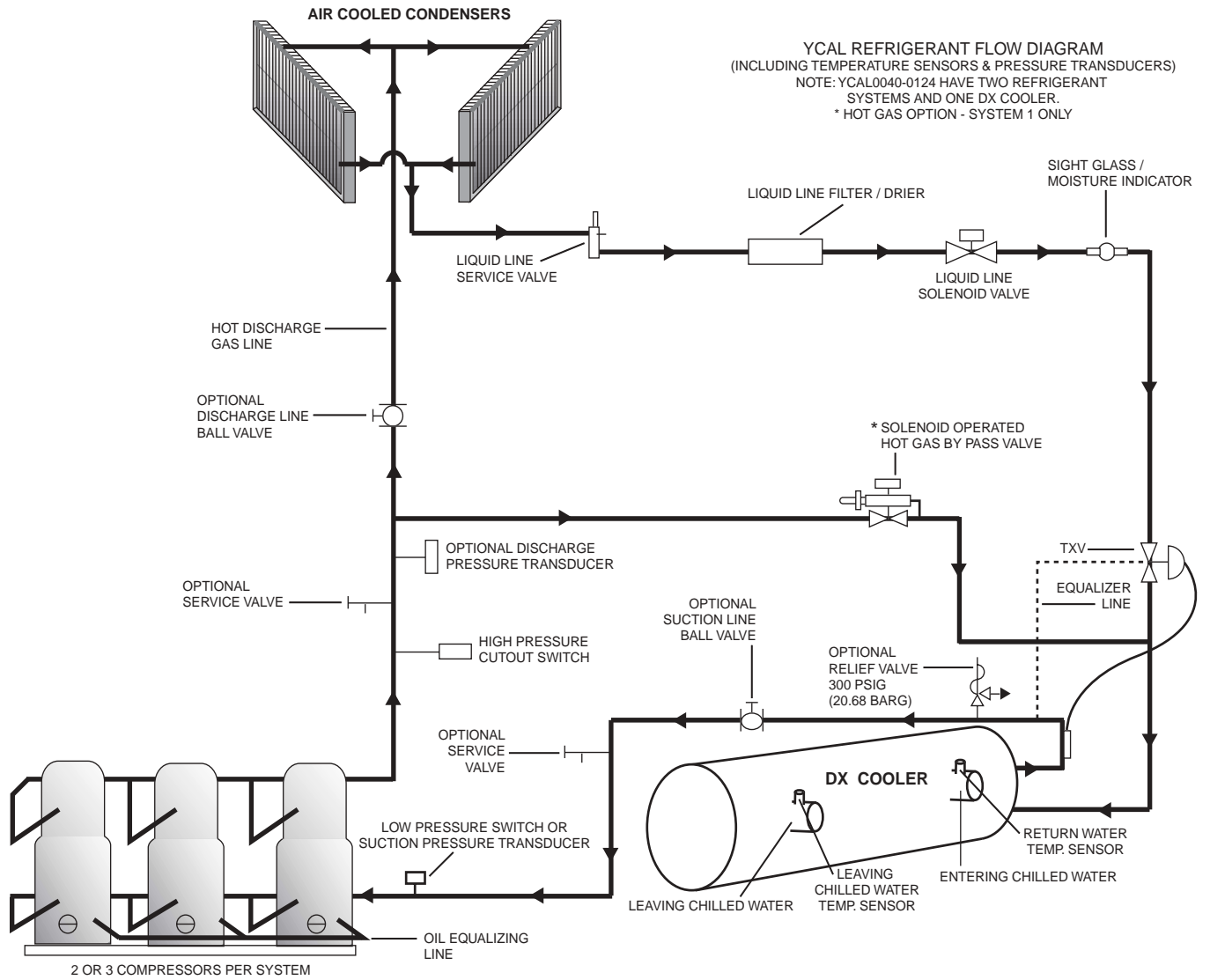

LD07613

FIG. 1 – REFRIGERANT FLOW DIAGRAM

INSTALLATION



To ensure warranty coverage, this equipment must be commissioned and serviced by an authorized YORK service mechanic or a qualified service person experienced in chiller installation. Installation must comply with all applicable codes, particularly in regard to electrical wiring and other safety elements such as relief valves, HP cutout settings, design working pressures, and ventilation requirements consistent with the amount and type of refrigerant charge.

Lethal voltages exist within the control panels. Before servicing, open and tag all disconnect switches.

The unit should be lifted by inserting hooks through the holes provided in unit base rails. Spreader bars should be used to avoid crushing the unit frame rails with the lifting chains. See below.



29224(RIG)A

INSTALLATION CHECK LIST

The following items, 1 through 5, must be checked before placing the units in operation.

1. Inspect the unit for shipping damage.
2. Rig unit using spreader bars.
3. Open the unit only to install water piping system. Do not remove protective covers from water connections until piping is ready for attachment. Check water piping to ensure cleanliness.
4. Pipe unit using good piping practice (see ASHRAE handbook section 215 and 195).
5. Check to see that the unit is installed and operated within limitations (Refer to LIMITATIONS).

The following pages outline detailed procedures to be followed to install and start-up the chiller.

HANDLING

These units are shipped as completely assembled units containing full operating charge, and care should be taken to avoid damage due to rough handling.

INSPECTION

Immediately upon receiving the unit, it should be inspected for possible damage which may have occurred during transit. If damage is evident, it should be noted in the carrier's freight bill. A written request for inspection by the carrier's agent should be made at once. See "Instruction" manual, Form 50.15-NM for more information and details.

LOCATION AND CLEARANCES

These units are designed for outdoor installations on ground level, rooftop, or beside a building. Location should be selected for minimum sun exposure and to insure adequate supply of fresh air for the condenser. The units must be installed with sufficient clearances for air entrance to the condenser coil, for air discharge away from the condenser, and for servicing access.

In installations where winter operation is intended and snow accumulations are expected, additional height must be provided to ensure normal condenser air flow.

Clearances are listed under "Notes" in the "DIMENSIONS" section.

FOUNDATION

The unit should be mounted on a flat and level foundation, floor, or rooftop capable of supporting the entire operating weight of the equipment. See PHYSICAL DATA for operating weight. If the unit is elevated beyond the normal reach of service personnel, a suitable catwalk must be capable of supporting service personnel, their equipment, and the compressors.

GROUND LEVEL LOCATIONS

It is important that the units be installed on a substantial base that will not settle. A one piece concrete slab with footers extended below the frost line is highly recommended. Additionally, the slab should not be tied to the main building foundations as noise and vibration may be transmitted. Mounting holes are provided in the steel channel for bolting the unit to its foundation. (See DIMENSIONS.)

For ground level installations, precautions should be taken to protect the unit from tampering by or injury to unauthorized persons. Screws and/or latches on access panels will prevent casual tampering. However, further safety precautions such as a fenced-in enclosure or locking devices on the panels may be advisable.

ROOFTOP LOCATIONS

Choose a spot with adequate structural strength to safely support the entire weight of the unit and service personnel. Care must be taken not to damage the roof.

Consult the building contractor or architect if the roof is bonded. Roof installations should have wooden beams (treated to reduce deterioration), cork, rubber, or vibration isolators under the base to minimize vibration.

NOISE SENSITIVE LOCATIONS

Efforts should be made to assure that the chiller is not located next to occupied spaces or noise sensitive areas where chiller noise level would be a problem. Chiller noise is a result of compressor and fan operation. Considerations should be made utilizing noise levels published in the YORK Engineering Guide for the specific chiller model. Sound blankets for the compressors and low sound fans are available.

SPRING ISOLATORS (OPTIONAL)

When ordered, four (4) isolators will be furnished.

Identify the isolator, locate at the proper mounting point, and adjust per instructions. See APPENDIX 1.

COMPRESSOR MOUNTING

The compressors are mounted on four (4) rubber isolators. The mounting bolts should not be loosened or adjusted at installation of the chiller.

REMOTE COOLER OPTION

For units using remote cooler option, refer to instructions included with miscellaneous cooler parts kit.

The unit and remote cooler is shipped with a 6 lb. (2.7 kg) nitrogen holding charge. The nitrogen charge must be removed, and system evacuated, and the refrigerant charge must be weighed-in according to the operating charge listed under PHYSICAL DATA. Additional charge must also be added for the refrigerant lines.

CHILLED WATER PIPING

General – When the unit has been located in its final position, the unit water piping may be connected. Normal installation precautions should be observed in order to receive maximum operating efficiencies. Piping should be kept free of all foreign matter. All chilled water evaporator piping must comply in all respects with local plumbing codes and ordinances.

Since elbows, tees and valves decrease pump capacity, all piping should be kept as straight and as simple as possible. **All piping must be supported independent of the chiller.**

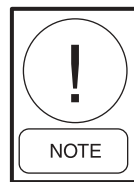

Consideration should be given to compressor access when laying out water piping. Routing the water piping too close to the unit could make compressor servicing/replacement difficult.

Hand stop valves should be installed in all lines to facilitate servicing.

Piping to the inlet and outlet connections of the chiller should include high-pressure rubber hose or piping loops to ensure against transmission of water pump vibration. The necessary components must be obtained in the field.

Drain connections should be provided at all low points to permit complete drainage of the cooler and system water piping.

A small valve or valves should be installed at the highest point or points in the chilled water piping to allow any trapped air to be purged. Vent and drain connections should be extended beyond the insulation to make them accessible.

The piping to and from the cooler must be designed to suit the individual installation. It is important that the following considerations be observed:

1. The chilled liquid piping system should be laid out so that the circulating pump discharges directly into the cooler. The suction for this pump should be taken from the piping system return line and not the cooler. This piping scheme is recommended, but is not mandatory.
2. The inlet and outlet cooler connection sizes are 3" (YCAL0014 - 0024), 4" (YCAL0030 - 0034), 6" (YCAL0040 - 0080), or 8" (YCAL0090 - 0124) .
3. A strainer, preferably 40 mesh, **must** be installed in the cooler inlet line just ahead of the cooler. This is important to protect the cooler from entrance of large particles which could cause damage to the evaporator.
4. All chilled liquid piping should be thoroughly flushed to free it from foreign material before the system is placed into operation. Use care not to flush any foreign material into or through the cooler.
5. As an aid to servicing, thermometers and pressure gauges should be installed in the inlet and outlet water lines.
6. The chilled water lines that are exposed to outdoor ambients should be wrapped with supplemental heater cable and insulated to protect against freeze-up during low ambient periods, and to prevent formation of condensation on lines in warm humid locations.
7. A chilled water flow switch, (either by YORK or others) **MUST** be installed in the leaving water piping of the cooler. There should be a straight horizontal run of at least 5 diameters on each side of the switch. Adjust the flow switch paddle to the size of the pipe in which it is to be installed. (See manufacturer's instructions furnished with the switch.) The switch is to be wired to terminals 13 - 14 of CTB1 located in the control panel, as shown on the unit wiring diagram.



The Flow Switch MUST NOT be used to start and stop the chiller (i.e. starting and stopping the chilled water pump). It is intended only as a safety switch.

WIRING

Liquid Chillers are shipped with all factory-mounted controls wired for operation.

Field Wiring – Power wiring must be provided through a fused disconnect switch to the unit terminals (or optional molded disconnect switch) in accordance with N.E.C. or local code requirements. Minimum circuit ampacity and maximum dual element fuse size are given in the Tables 2 – 6.

A 120-1-60, 15 amp source must be supplied for the control panel through a fused disconnect when a control panel transformer (optional) is not provided. Refer to Table 1 and Figures 2 - 6.

See Figures 2 - 6 and unit wiring diagrams for field and power wiring connections, chilled water pump starter contacts, alarm contacts, compressor run status contacts, PWM input, and load limit input. Refer to section on UNIT OPERATION for a detailed description of operation concerning aforementioned contacts and inputs.

EVAPORATOR PUMP START CONTACTS

Terminal block CTB2 – terminals 23 to 24, are normally-open contacts that can be used to switch field supplied power to provide a start signal to the evaporator pump contactor. The contacts will be closed when any of the following conditions occur:

1. Low Leaving Chilled Liquid Fault
2. Any compressor is running
3. Daily schedule is not programmed OFF and the Unit Switch is ON

The pump will not run if the micro panel has been powered up for less than 30 seconds, or if the pump has run in the last 30 seconds, to prevent pump motor overheating. Refer to Figure 6 and unit wiring diagram.

SYSTEM RUN CONTACTS

Contacts are available to monitor system status. Normally-open auxiliary contacts from each compressor contactor are wired in parallel with CTB2 – terminals 25 to 26 for system 1, and CTB2 – terminals 27 to 28 for system 2 (YCAL0040 - YCAL0124). Refer to Figure 6 and unit wiring diagram.

ALARM STATUS CONTACTS

Normally-open contacts are available for each refrigerant system. These normally-open contacts close when the system is functioning normally. The respective contacts will open when the unit is shut down on a unit fault, or locked out on a system fault. Field connections are at CTB2 terminals 29 to 30 (system 1), and terminals 31 to 32 (system 2 YCAL0040 - YCAL0124).

REMOTE START/STOP CONTACTS

To remotely start and stop the chiller, dry contacts can be wired in series with the flow switch and CTB1 - terminals 13 to 14. Refer to Figure 6 and unit wiring diagram.

REMOTE EMERGENCY CUTOFF

Immediate shutdown of the chiller can be accomplished by opening a field-installed dry contact to break the elec-

trical circuit between terminals 5 to L on terminal block CTB2. The unit is shipped with a factory jumper installed between terminals 5 to L, which must be removed if emergency shutdown contacts are installed. Refer to Figure 6 and unit wiring diagram.

PWM INPUT

The PWM input allows reset of the chilled liquid set-point by supplying a “timed” contact closure. Field wiring should be connected to CTB1 – terminals 13 to 20. A detailed explanation is provided in the Unit Control section. Refer to Figure 6 and unit wiring diagram.

LOAD LIMIT INPUT

Load limiting is a feature that prevents the unit from loading beyond a desired value. The unit can be “load limited” either 33%, 40%, 50%, 66% or 80%, depending on the number of compressors on unit. The field connections are wired to CTB1 – terminals 13 to 21, and work in conjunction with the PWM inputs. A detailed explanation is provided in the Unit Control section. Refer to Figure 6 and unit wiring diagram.

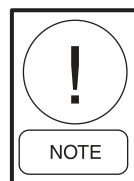

When using the Load Limit feature, the PWM feature will not function – SIMULTANEOUS OPERATION OF LOAD LIMITING AND TEMPERATURE RESET (PWM INPUT) CANNOT BE DONE.

FLOW SWITCH INPUT

The flow switch is field wired to CTB1 terminals 13 - 14. See Figure 6 and unit wiring diagram.

COMPRESSOR HEATERS

Compressor heaters are standard. SM90 - SM160 compressors utilize 50W heaters; SM185 compressors utilize 75W heaters. If power is OFF more than two hours, the crankcase heaters must be energized for 18 - 24 hours prior to restarting a compressor. This will assure that liquid slugging and oil dilution does not damage the compressors on start.

SINGLE-POINT SUPPLY CONNECTION – TERMINAL BLOCK, NON-FUSED DISCONNECT SWITCH OR CIRCUIT BREAKER (0014 - 0080)

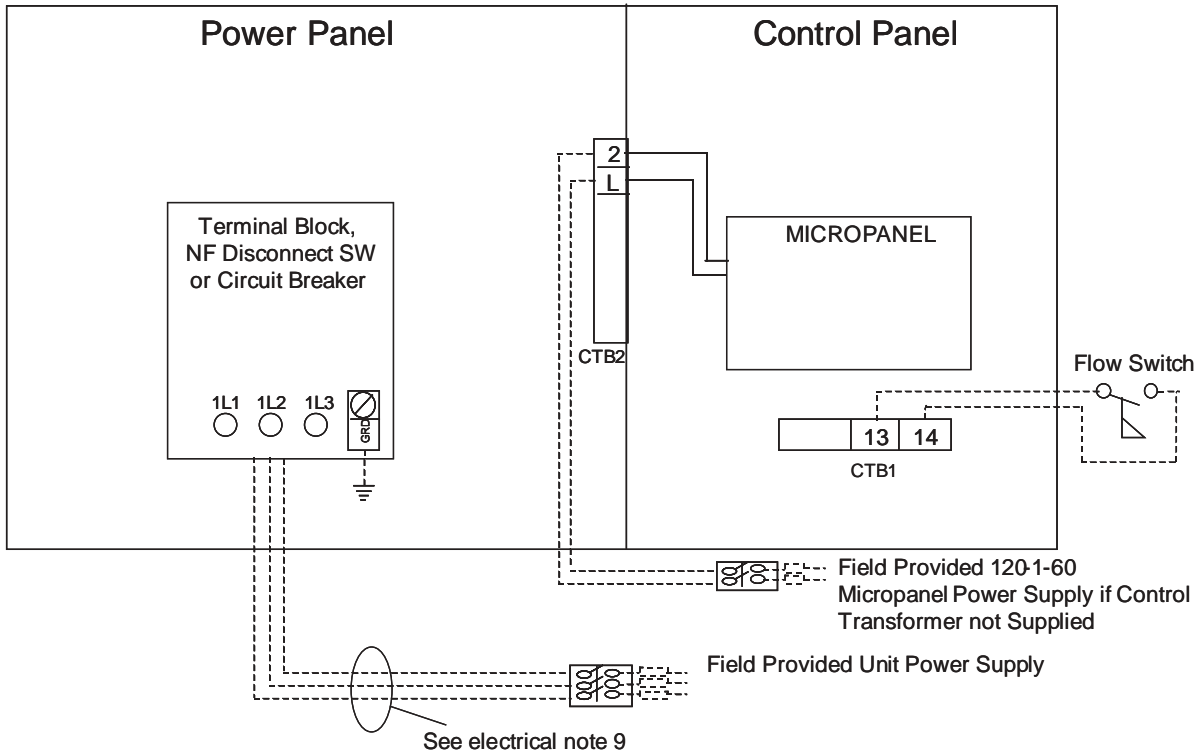

* Models YCAL0040-0080 Only (Models YCAL0014-0034 are Single Point)

Electrical Notes and Legend located on page 19.



*It is possible that multiple sources of power can be supplying the unit power panel. To prevent serious injury or death, the technician should verify that **NO LETHAL VOLTAGES** are present inside the panel **AFTER** disconnecting power, **PRIOR** to working on equipment.*



The unit evaporator heater uses 120VAC. Disconnecting 120VAC power from the unit, at or below freezing temperatures, can result in damage to the evaporator and unit as a result of the chilled liquid freezing.

FIG. 2 – SINGLE-POINT SUPPLY CONNECTION – TERMINAL BLOCK, NON-FUSED DISCONNECT SWITCH OR CIRCUIT BREAKER (0014 - 0080)

MULTIPLE POINT POWER SUPPLY CONNECTION – TERMINAL BLOCK (0040 - 0080)

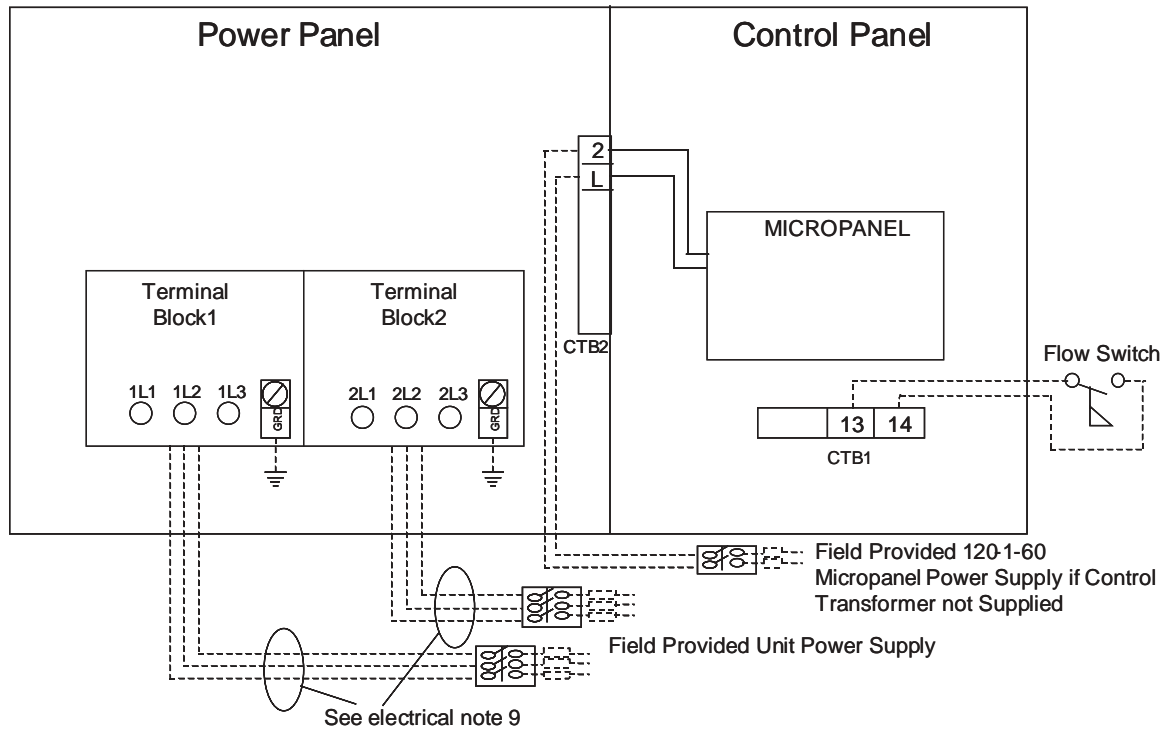

Electrical Notes and Legend located on page 19.



It is possible that multiple sources of power can be supplying the unit power panel. To prevent serious injury or death, the technician should verify that NO LETHAL VOLTAGES are present inside the panel AFTER disconnecting power, PRIOR to working on equipment.



The unit evaporator heater uses 120VAC. Disconnecting 120VAC power from the unit, at or below freezing temperatures, can result in damage to the evaporator and unit as a result of the chilled liquid freezing.

FIG. 3 – MULTIPLE POINT POWER SUPPLY CONNECTION – TERMINAL BLOCK (0040 - 0080)

MULTIPLE POINT POWER SUPPLY CONNECTION – TERMINAL BLOCK, NON-FUSED DISCONNECT SWITCHES OR CIRCUIT BREAKERS (0090 - 0124)

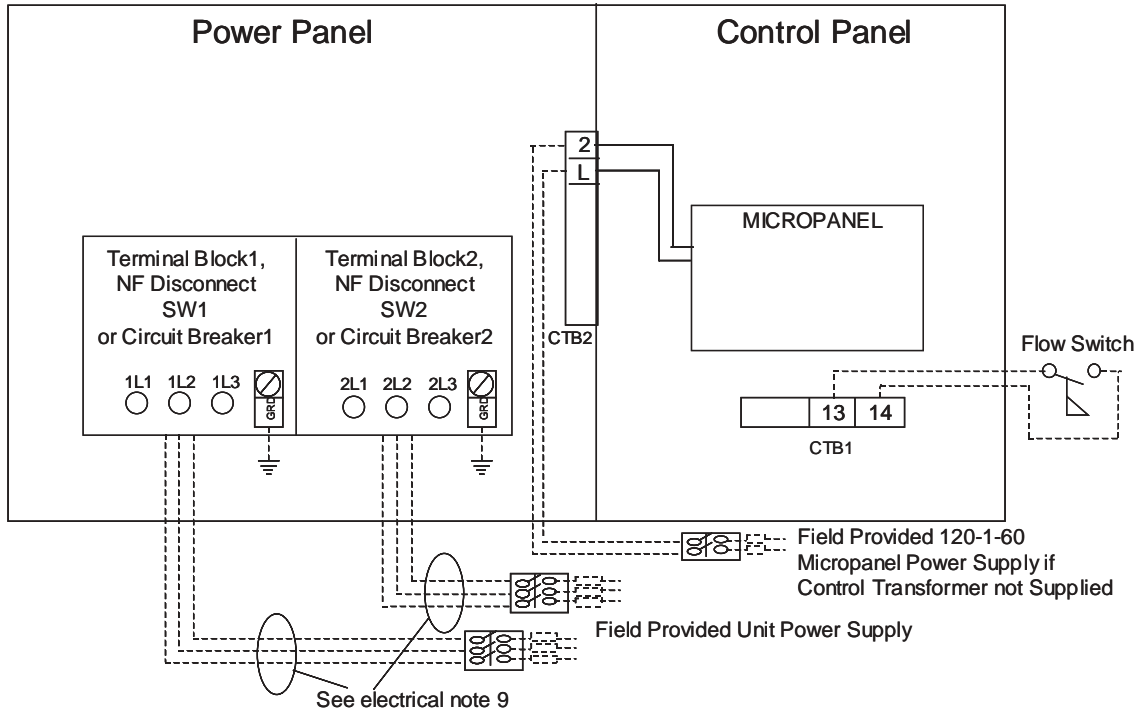

Electrical Notes and Legend located on page 19.



*It is possible that multiple sources of power can be supplying the unit power panel. To prevent serious injury or death, the technician should verify that **NO LETHAL VOLTAGES** are present inside the panel **AFTER** disconnecting power, **PRIOR** to working on equipment.*



The unit evaporator heater uses 120VAC. Disconnecting 120VAC power from the unit, at or below freezing temperatures, can result in damage to the evaporator and unit as a result of the chilled liquid freezing.

FIG. 4 – MULTIPLE POINT POWER SUPPLY CONNECTION – TERMINAL BLOCK, NON-FUSED DISCONNECT SWITCHES OR CIRCUIT BREAKERS (0090 - 0124)

SINGLE-POINT SUPPLY CONNECTION – TERMINAL BLOCK OR NON-FUSED DISCONNECT SWITCH TO INDIVIDUAL SYSTEM CIRCUIT BREAKERS (0090 - 0124)

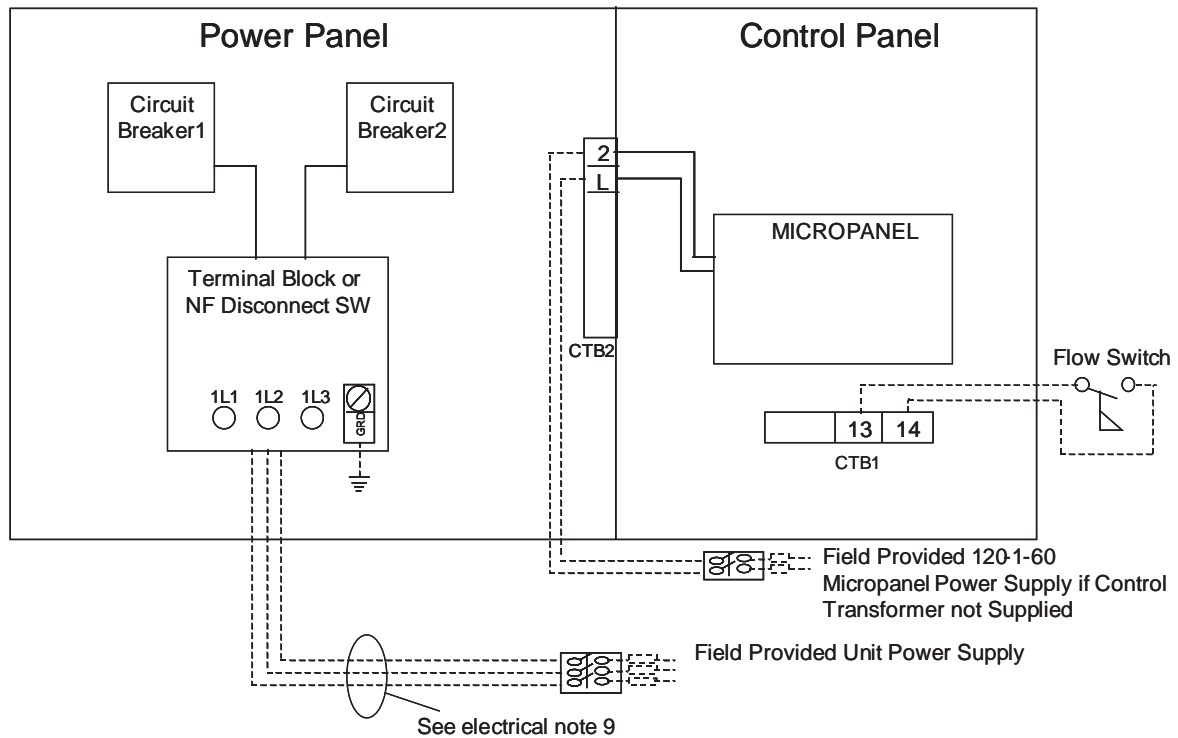

Electrical Notes and Legend located on page 19.



*It is possible that multiple sources of power can be supplying the unit power panel. To prevent serious injury or death, the technician should verify that **NO LETHAL VOLTAGES** are present inside the panel **AFTER** disconnecting power, **PRIOR** to working on equipment.*



The unit evaporator heater uses 120VAC. Disconnecting 120VAC power from the unit, at or below freezing temperatures, can result in damage to the evaporator and unit as a result of the chilled liquid freezing.

FIG. 5 – OPTIONAL SINGLE-POINT POWER WIRING

CONTROL WIRING

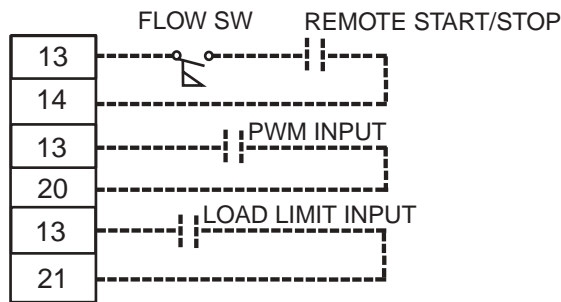

CTB1

LD07725

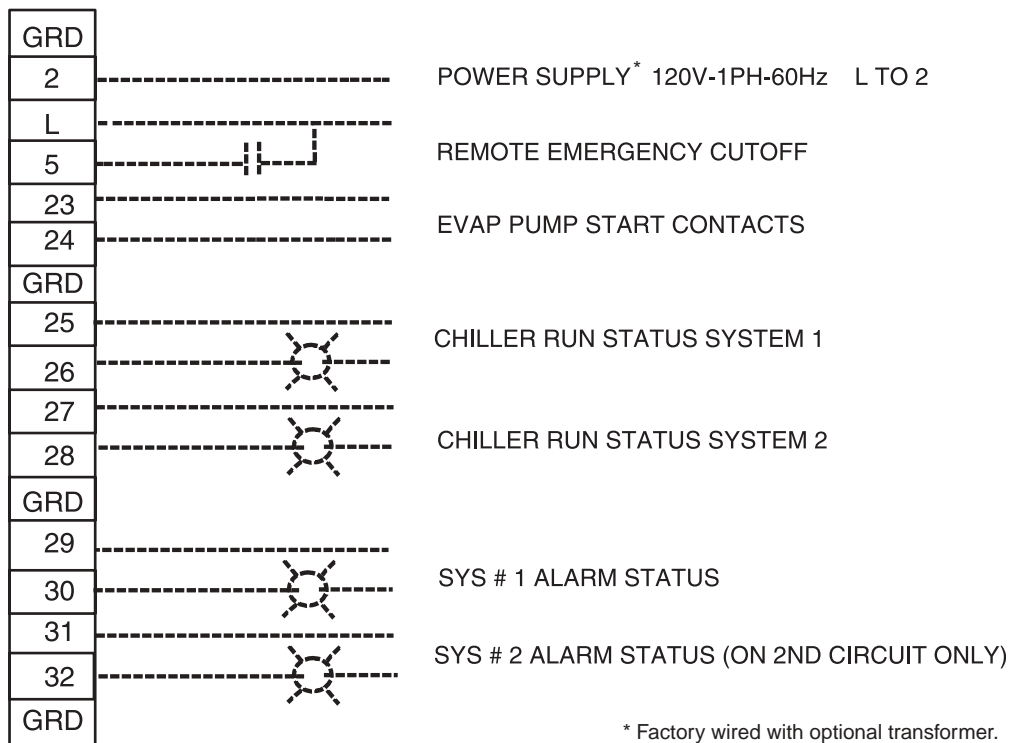

CTB2

LD07730

* Factory wired with optional transformer.



*It is possible that multiple sources of power can be supplying the unit power panel. To prevent serious injury or death, the technician should verify that **NO LETHAL VOLTAGES** are present inside the panel **AFTER** disconnecting power, **PRIOR** to working on equipment.*



The unit evaporator heater uses 120VAC. Disconnecting 120VAC power from the unit, at or below freezing temperatures, can result in damage to the evaporator and unit as a result of the chilled liquid freezing.

FIG. 6 – CONTROL WIRING

ELECTRICAL NOTES AND LEGEND

NOTES:

1. Minimum Circuit Ampacity (MCA) is based on 125% of the rated load amps for the largest motor plus 100% of the rated load amps for all other loads included in the circuit, per N.E.C. Article 430.33. If the Factory-mounted Control Transformer is provided, add the following to the system MCA values in the electrical tables for the system supplying power to the optional transformer. -17, add 2.5 amps; -28, add 2.3 amps; -40, add 1.5 amps, -46, add 1.3 amps; -58, add 1 amp.
2. The minimum recommended disconnect switch is based on 115% of the rated load amps for all loads included in the circuit, per N.E.C. Article 440.12 (A) 1.
3. Minimum fuse size is based upon 150% of the rated load amps for the largest motor plus 100% of the rated load amps for all other loads included in the circuit to avoid nuisance trips at start-up due to lock rotor amps. It is not recommended in applications where brown outs, frequent starting and stopping of the unit, and/or operation at ambient temperatures in excess of 95°F is anticipated.
4. Maximum fuse size is based upon 225% of the rated load amps for the largest motor plus 100% of the rated load amps for all other loads included in the circuit, per N.E.C. Article 440.22.
5. Circuit breakers must be U.L. listed and CSA certified and maximum size is based on 225% of the rated load amps for the largest motor plus 100% of the rated load amps for all other loads included in the circuit. Exception: YCAL0014 and YCAL0020 must have the optional factory overloads installed to use a standard circuit breaker. Otherwise, an HACR-type circuit breakers must be used. Maximum HACR circuit breaker rating is based on 225% of the rated load amps for the largest motor plus 100% of the rated load amps for all other loads included in the circuit.
6. The "INCOMING WIRE RANGE" is the minimum and maximum wire size that can be accommodated by the unit wiring lugs. The (2) preceding the wire range indicates the number of termination points available per phase of the wire range specified. Actual wire size and number of wires per phase must be determined based on the National Electrical Code, using copper connectors only. Field wiring must also comply with local codes.
7. A ground lug is provided for each compressor system to accommodate a field grounding conductor per N.E.C. Table 250.122. A control circuit grounding lug is also supplied.
8. The supplied disconnect is a "Disconnecting Means" as defined in the N.E.C. 100.1, and is intended for isolating the unit for the available power supply to perform maintenance and troubleshooting. This disconnect is not intended to be a Load Break Device.
9. Field Wiring by others which complies to the National Electrical Code and Local Codes.

LEGEND	
ACR-LINE	ACROSS -THE-LINE START
C.B.	CIRCUIT BREAKER
D.E.	DUAL ELEMENT FUSE
DISC SW	DISCONNECT SWITCH
FACT MOUNT CB	FACTORY-MOUNTED CIRCUIT BREAKER
FLA	FULL LOAD AMPS
HZ	HERTZ
MAX	MAXIMUM
MCA	MINIMUM CIRCUIT AMPACITY
MIN	MINIMUM
MIN NF	MINIMUM NON FUSED
RLA	RATED LOAD AMPS
S.P. WIRE	SINGLE-POINT WIRING
UNIT MTD SERV SW	UNIT MOUNTED SERVICE (NON-FUSED DISCONNECT SWITCH)
LRA	LOCKED ROTOR AMPS

VOLTAGE CODE

-17	= 200-3-60
-28	= 230-3-60
-40	= 380-3-60
-46	= 460-3-60
-58	= 575-3-60

LEGEND:

Field Wiring - - - - -
 Factory Wiring _____

ELECTRICAL DATA

TABLE 1 – MICRO PANEL POWER SUPPLY

UNIT VOLTAGE	UNIT VOLTAGE	CONTROL POWER	MCA	OVER CURRENT PROTECTION, SEE NOTE B		NF DISC SW
			NOTE A	MIN	MAX	
MODELS w/o CONTROL TRANS		115-1-60/50	15A	10A	15A	30 A / 240V
MODELS w/ CONTROL TRANS	-17	200-1-60	15A	10A	15A	30 A / 240V
	-28	230-1-60	15A	10A	15A	30 A / 240V
	-40	380-1-60	15A	10A	15A	30 A / 480V
	-46	460-1-60	15A	10A	15A	30 A / 480V
	-58	575-1-60	15A	10A	15A	30 A / 600V

A. Minimum #14 AWG, 75°C, Copper Recommended

B. Minimum and Maximum Over Current Protection, Dual Element Fuse or Circuit Breaker



*It is possible that multiple sources of power can be supplying the unit power panel. To prevent serious injury or death, the technician should verify that **NO LETHAL VOLTAGES** are present inside the panel **AFTER** disconnecting power, **PRIOR** to working on equipment.*



The unit evaporator heater uses 120VAC. Disconnecting 120VAC power from the unit, at or below freezing temperatures, can result in damage to the evaporator and unit as a result of the chilled liquid freezing.

ELECTRICAL DATA

SINGLE-POINT POWER SUPPLY CONNECTIONS – YCAL0014E_ - YCAL0034E_

(One Field Provided Power Supply to the chiller. Field connections to Factory Provided Power Terminal Block (standard), Non-Fused Disconnect Switch (optional) or Circuit Breaker (optional).)

TABLE 2 – SINGLE-POINT POWER SUPPLY

MODEL YCAL	SINGLE-POINT FIELD SUPPLIED WIRING									SYSTEM #1 COMPRESSOR & FAN							
	VOLT	HZ	MCA ¹	MIN NF DISC SW ²	D.E. FUSE		CKT. BKR. ⁵		INCOMING (LUG) WIRE RANGE ⁶	COMPR. #1		COMPR. #2		COMPR. #3		FANS	
					MIN ³	MAX ⁴	MIN	MAX		RLA	LRA	RLA	LRA	RLA	LRA	QTY	FLA (EA)
0014	200	60	75	100	90	100	90	100	# 18 - # 2	26.0	195	26.0	195	—	—	2	8.2
	230	60	70	100	80	90	80	90	# 18 - # 2	24.1	195	24.1	195	—	—	2	7.8
	380	60	42	60	45	50	45	50	# 20 - # 6	14.0	113	14.0	113	—	—	2	4.8
	460	60	34	60	40	40	40	40	# 20 - # 6	11.5	98	11.5	98	—	—	2	3.8
	575	60	27	30	30	35	30	35	# 20 - # 6	9.2	80	9.2	80	—	—	2	3.1
0020	200	60	100	150	110	125	110	125	# 6 - 1/0	37.0	237	37.0	237	—	—	2	8.2
	230	60	93	100	110	125	110	125	# 6 - 1/0	34.3	237	34.3	237	—	—	2	7.8
	380	60	52	60	60	60	60	60	# 18 - # 2	18.5	154	18.5	154	—	—	2	4.8
	460	60	45	60	50	60	50	60	# 20 - # 6	16.3	130	16.3	130	—	—	2	3.8
	575	60	36	60	40	45	40	45	# 20 - # 6	13.1	85	13.1	85	—	—	2	3.1
0024	200	60	127	150	150	175	150	175	# 2 - 4/0	49.1	298	49.1	298	—	—	2	8.2
	230	60	118	150	150	150	150	150	# 2 - 4/0	45.5	298	45.5	298	—	—	2	7.8
	380	60	76	100	90	100	90	100	# 18 - # 2	29.5	235	29.5	235	—	—	2	4.8
	460	60	57	60	70	70	70	70	# 18 - # 2	21.7	170	21.7	170	—	—	2	3.8
	575	60	46	60	50	60	50	60	# 20 - # 6	17.3	140	17.3	140	—	—	2	3.1
0030	200	60	140	150	175	175	175	175	# 2 - 4/0	54.7	420	54.7	420	—	—	2	8.2
	230	60	130	150	150	175	150	175	# 2 - 4/0	50.7	420	50.7	420	—	—	2	7.8
	380	60	75	100	90	100	90	100	# 18 - # 2	28.7	235	28.7	235	—	—	2	4.8
	460	60	62	100	70	80	70	80	# 18 - # 2	24.1	175	24.1	175	—	—	2	3.8
	575	60	50	60	60	60	60	60	# 18 - # 2	19.3	140	19.3	140	—	—	2	3.1
0034	200	60	183	200	200	225	200	225	1/0 - 300	51.2	298	51.2	298	51.2	298	2	8.2
	230	60	170	200	200	200	200	200	1/0 - 300	47.4	298	47.4	298	47.4	298	2	7.8
	380	60	103	150	110	125	110	125	# 6 - 1/0	28.7	235	28.7	235	28.7	235	2	4.8
	460	60	81	100	90	100	90	100	# 18 - # 2	22.6	175	22.6	175	22.6	175	2	3.8
	575	60	65	100	70	80	70	80	# 18 - # 2	18.0	140	18.0	140	18.0	140	2	3.1

See Notes and Legend on page 19.

ELECTRICAL DATA – DUAL POINT POWER SUPPLY CONNECTIONS – YCAL0040E_ - YCAL0080E_

(Two Field Provided Power Supply Circuits to the chiller. Field connections to Factory Provided Terminal Blocks per system)

TABLE 3 – DUAL POINT POWER SUPPLY CONNECTIONS

MODEL YCAL	SYSTEM #1 FIELD SUPPLIED WIRING									SYSTEM #1 COMPRESSOR & FAN							
	VOLT	HZ	MCA ¹	MIN N/F DISC SW ²	D.E. FUSE		CKT. BKR. ⁵		INCOMING (LUG) WIRE RANGE ⁶	COMPR. #1		COMPR. #2		COMPR. #3		FANS	
					MIN ³	MAX ⁴	MIN	MAX		RLA	LRA	RLA	LRA	RLA	LRA	QTY	FLA (EA)
0040E_	200	60	91	100	100	110	100	110	# 6 - 1/0	32.9	265	32.9	265	—	—	2	8.2
	230	60	85	100	100	110	100	110	# 18 - # 2	30.5	265	30.5	265	—	—	2	7.8
	380	60	54	60	60	70	60	70	# 18 - # 2	19.4	155	19.4	155	—	—	2	4.8
	460	60	41	60	45	50	45	50	# 20 - # 6	14.5	120	14.5	120	—	—	2	3.8
	575	60	33	60	40	40	40	40	# 20 - # 6	11.6	80	11.6	80	—	—	2	3.1
0042E_	200	60	130	150	150	175	150	175	# 6 - 1/0	50.2	298	50.2	298	—	—	2	8.2
	230	60	121	150	150	150	150	150	# 6 - 1/0	46.5	298	46.5	298	—	—	2	7.8
	380	60	73	100	80	100	80	100	# 18 - # 2	28.1	235	28.1	235	—	—	2	4.8
	460	60	58	60	70	70	70	70	# 18 - # 2	22.1	170	22.1	170	—	—	2	3.8
	575	60	47	60	60	60	60	60	# 20 - # 6	17.7	140	17.7	140	—	—	2	3.1
0044E_	200	60	130	150	150	175	150	175	# 2 - 4/0	50.2	298	50.2	298	—	—	2	8.2
	230	60	121	150	150	150	150	150	# 2 - 4/0	46.5	298	46.5	298	—	—	2	7.8
	380	60	73	100	80	100	80	100	# 18 - # 2	28.1	235	28.1	235	—	—	2	4.8
	460	60	58	60	70	70	70	70	# 18 - # 2	22.1	170	22.1	170	—	—	2	3.8
	575	60	47	60	60	60	60	60	# 18 - # 2	17.7	140	17.7	140	—	—	2	3.1
0050E_	200	60	146	200	175	200	175	200	# 2 - 4/0	57.4	420	57.4	420	—	—	2	8.2
	230	60	136	150	150	175	150	175	# 2 - 4/0	53.1	420	53.1	420	—	—	2	7.8
	380	60	79	100	90	100	90	100	# 18 - # 2	30.8	235	30.8	235	—	—	2	4.8
	460	60	65	100	80	80	80	80	# 18 - # 2	25.3	175	25.3	175	—	—	2	3.8
	575	60	52	60	60	70	60	70	# 18 - # 2	20.2	140	20.2	140	—	—	2	3.1
0060E_	200	60	141	150	175	175	175	175	# 2 - 4/0	55.0	420	55.0	420	—	—	2	8.2
	230	60	131	150	150	175	150	175	# 2 - 4/0	50.9	420	50.9	420	—	—	2	7.8
	380	60	77	100	90	100	90	100	# 18 - # 2	29.6	235	29.6	235	—	—	2	4.8
	460	60	63	100	70	80	70	80	# 18 - # 2	24.2	175	24.2	175	—	—	2	3.8
	575	60	50	60	60	60	60	60	# 18 - # 2	19.4	140	19.4	140	—	—	2	3.1
0064E_	200	60	187	200	200	225	200	225	# 6 - 400	52.4	298	52.4	298	52.4	298	2	8.2
	230	60	174	200	200	200	200	200	# 6 - 400	48.6	298	48.6	298	48.6	298	2	7.8
	380	60	105	150	125	125	125	125	# 6 - 1/0	29.3	235	29.3	235	29.3	235	2	4.8
	460	60	83	100	90	100	90	100	# 18 - # 2	23.1	170	23.1	170	23.1	170	2	3.8
	575	60	67	100	80	80	80	80	# 18 - # 2	18.5	140	18.5	140	18.5	140	2	3.1
0070E_	200	60	185	200	200	225	200	225	# 6 - 400	51.8	298	51.8	298	51.8	298	2	8.2
	230	60	172	200	200	200	200	200	# 6 - 400	48.0	298	48.0	298	48.0	298	2	7.8
	380	60	104	150	125	125	125	125	# 6 - 1/0	29.0	235	29.0	235	29.0	235	2	4.8
	460	60	82	100	90	100	90	100	# 18 - # 2	22.9	170	22.9	170	22.9	170	2	3.8
	575	60	66	100	80	80	80	80	# 18 - # 2	18.3	140	18.3	140	18.3	140	2	3.1
0074E_	200	60	208	250	225	250	225	250	# 6 - 400	58.9	420	58.9	420	58.9	420	2	8.2
	230	60	193	250	225	225	225	225	# 6 - 400	54.5	420	54.5	420	54.5	420	2	7.8
	380	60	113	150	125	125	125	125	# 6 - 1/0	31.6	235	31.6	235	31.6	235	2	4.8
	460	60	92	100	100	110	100	110	# 6 - 1/0	26.0	175	26.0	175	26.0	175	2	3.8
	575	60	74	100	80	90	80	90	# 18 - # 2	20.8	140	20.8	140	20.8	140	2	3.1
0080E_	200	60	207	250	225	250	225	250	# 6 - 400	58.6	420	58.6	420	58.6	420	2	8.2
	230	60	192	250	225	225	225	225	# 6 - 400	54.2	420	54.2	420	54.2	420	2	7.8
	380	60	112	150	125	125	125	125	# 6 - 1/0	31.5	235	31.5	235	31.5	235	2	4.8
	460	60	92	100	100	110	100	110	# 6 - 1/0	25.8	175	25.8	175	25.8	175	2	3.8
	575	60	74	100	80	90	80	90	# 18 - # 2	20.7	140	20.7	140	20.7	140	2	3.1

See Notes and Legend on page 19.

SYSTEM #2 FIELD SUPPLIED WIRING							SYSTEM #2 COMPRESSOR & FAN							
MCA ¹	MIN NF	D.E. FUSE		CKT. BRK. ⁵		INCOMING (LUG) WIRE RANGE ⁶	COMPR. #1		COMPR. #2		COMPR. #3		FANS	
	DISC SW ²	MIN ³	MAX ⁴	MIN	MAX		RLA	LRA	RLA	LRA	RLA	LRA	QTY	FLA (EA)
91	100	100	110	100	110	# 6 - 1/0	32.9	265	32.9	265	—	—	2	8.2
85	100	100	110	100	110	# 18 - # 2	30.5	265	30.5	265	—	—	2	7.8
54	60	60	70	60	70	# 18 - # 2	19.4	155	19.4	155	—	—	2	4.8
41	60	45	50	45	50	# 20 - # 6	14.5	120	14.5	120	—	—	2	3.8
33	60	40	40	40	40	# 20 - # 6	11.6	80	11.6	80	—	—	2	3.1
91	100	100	110	100	110	# 18 - # 2	32.9	265	32.9	265	—	—	2	8.2
85	100	100	110	100	110	# 18 - # 2	30.5	265	30.5	265	—	—	2	7.8
54	60	60	70	60	70	# 20 - # 6	19.4	155	19.4	155	—	—	2	4.8
41	60	45	50	45	50	# 20 - # 6	14.5	120	14.5	120	—	—	2	3.8
33	60	40	40	40	40	# 20 - # 6	11.6	80	11.6	80	—	—	2	3.1
130	150	150	175	150	175	# 2 - 4/0	50.2	298	50.2	298	—	—	2	8.2
121	150	150	150	150	150	# 2 - 4/0	46.5	298	46.5	298	—	—	2	7.8
73	100	80	100	80	100	# 18 - # 2	28.1	235	28.1	235	—	—	2	4.8
58	60	70	70	70	70	# 18 - # 2	22.1	170	22.1	170	—	—	2	3.8
47	60	60	60	60	60	# 18 - # 2	17.7	140	17.7	140	—	—	2	3.1
130	150	150	175	150	175	# 2 - 4/0	49.5	298	49.5	298	—	—	2	8.2
121	150	150	150	150	150	# 2 - 4/0	45.9	298	45.9	298	—	—	2	7.8
73	100	80	100	80	100	# 18 - # 2	27.8	235	27.8	235	—	—	2	4.8
58	60	70	70	70	70	# 18 - # 2	21.8	170	21.8	170	—	—	2	3.8
47	60	60	60	60	60	# 18 - # 2	17.5	140	17.5	140	—	—	2	3.1
141	150	175	175	175	175	# 2 - 4/0	55.0	420	55.0	420	—	—	2	8.2
131	150	150	175	150	175	# 2 - 4/0	50.9	420	50.9	420	—	—	2	7.8
77	100	90	100	90	100	# 18 - # 2	29.6	235	29.6	235	—	—	2	4.8
63	100	70	80	70	80	# 18 - # 2	24.2	175	24.2	175	—	—	2	3.8
50	60	60	60	60	60	# 18 - # 2	19.4	140	19.4	140	—	—	2	3.1
128	150	150	150	150	150	# 6 - 400	34.2	265	34.2	265	34.2	265	2	8.2
119	150	150	150	150	150	# 6 - 400	31.6	265	31.6	265	31.6	265	2	7.8
76	100	90	90	90	90	# 18 - # 2	20.2	155	20.2	155	20.2	155	2	4.8
57	100	70	70	70	70	# 18 - # 2	15.1	120	15.1	120	15.1	120	2	3.8
46	60	50	50	50	50	# 18 - # 2	12.0	80	12.0	80	12.0	80	2	3.1
185	200	200	225	200	225	# 6 - 400	51.8	298	51.8	298	51.8	298	2	8.2
172	200	200	200	200	200	# 6 - 400	48.0	298	48.0	298	48.0	298	2	7.8
104	150	125	125	125	125	# 6 - 1/0	29.0	235	29.0	235	29.0	235	2	4.8
82	100	90	100	90	100	# 18 - # 2	22.9	170	22.9	170	22.9	170	2	3.8
66	100	80	80	80	80	# 18 - # 2	18.3	140	18.3	140	18.3	140	2	3.1
181	200	200	225	200	225	# 6 - 400	50.5	298	50.5	298	50.5	298	2	8.2
168	200	200	200	200	200	# 6 - 400	46.8	298	46.8	298	46.8	298	2	7.8
102	150	110	125	110	125	# 6 - 1/0	28.3	235	28.3	235	28.3	235	2	4.8
80	100	90	100	90	100	# 18 - # 2	22.3	170	22.3	170	22.3	170	2	3.8
65	100	70	80	70	80	# 18 - # 2	17.8	140	17.8	140	17.8	140	2	3.1
207	250	225	250	225	250	# 6 - 400	58.6	420	58.6	420	58.6	420	2	8.2
192	250	225	225	225	225	# 6 - 400	54.2	420	54.2	420	54.2	420	2	7.8
112	150	125	125	125	125	# 6 - 1/0	31.5	235	31.5	235	31.5	235	2	4.8
92	100	100	110	100	110	# 6 - 1/0	25.8	175	25.8	175	25.8	175	2	3.8
74	100	80	90	80	90	# 18 - # 2	20.7	140	20.7	140	20.7	140	2	3.1

ELECTRICAL DATA – SINGLE POINT POWER SUPPLY CONNECTIONS – YCAL0040E_ - YCAL0080E_

(One Field Provided Power Supply Circuit to the chiller. Field connections to Factory Provided Terminal Block (optional), Non-Fused Disconnect Switch (optional) or Circuit Breaker (optional).)

TABLE 4 – SINGLE POINT POWER SUPPLY CONNECTIONS

SINGLE POINT FIELD SUPPLIED WIRING											
MODEL YCAL	VOLT	HZ	MCA ¹	MIN N/F DISC SW ²	D.E. FUSE		CKT. BKR. ⁵		INCOMING WIRE RANGE ⁶		
					MIN ³	MAX ⁴	MIN	MAX	FACTORY SUPPLIED OPTIONAL		
									SINGLE POINT	DISCONNECT	BREAKER
0040E_	200	60	173	200	200	200	200	200	#2 - 4/0	#4 - 300	#4 - 300
	230	60	161	200	175	175	175	175	#2 - 4/0	#4 - 300	#4 - 300
	380	60	102	150	110	110	110	110	# 6 - 1/0	# 2 - 4/0	# 2 - 4/0
	460	60	77	100	90	90	90	90	# 18 - # 2	# 14 - 1/0	# 14 - 1/0
	575	60	62	100	70	70	70	70	# 18 - # 2	# 14 - 1/0	# 14 - 1/0
0042E_	200	60	212	250	225	250	225	250	# 4 - 500	# 6 - 350	#4 - 300
	230	60	197	250	225	225	225	225	# 4 - 500	# 6 - 350	#4 - 300
	380	60	122	150	150	150	150	150	# 6 - 1/0	# 2 - 4/0	# 2 - 4/0
	460	60	95	150	100	110	100	110	# 6 - 1/0	# 2 - 4/0	# 14 - 1/0
	575	60	76	100	80	90	80	90	# 18 - # 2	# 14 - 1/0	# 14 - 1/0
0044E_	200	60	247	400	300	300	300	300	# 4 - 500	250 - 500	250 - 500
	230	60	229	250	250	250	250	250	# 4 - 500	# 6 - 350	# 6 - 350
	380	60	139	200	150	150	150	150	#2 - 4/0	# 4 - 300	# 2 - 4/0
	460	60	110	150	125	125	125	125	# 6 - 1/0	# 2 - 4/0	# 2 - 4/0
	575	60	88	100	100	100	100	100	# 6 - 1/0	# 14 - 1/0	# 14 - 1/0
0050E_	200	60	261	400	300	300	300	300	# 4 - 500	250 - 500	250 - 500
	230	60	243	400	300	300	300	300	# 4 - 500	250 - 500	250 - 500
	380	60	145	200	175	175	175	175	#2 - 300	# 4 - 300	# 4 - 300
	460	60	116	150	125	125	125	125	# 2 - 4/0	# 2 - 4/0	# 2 - 4/0
	575	60	93	150	100	110	100	110	# 6 - 4/0	# 2 - 4/0	# 14 - 1/0
0060E_	200	60	267	400	300	300	300	300	# 4 - 500	250 - 500	250 - 500
	230	60	248	400	300	300	300	300	# 4 - 500	250 - 500	250 - 500
	380	60	145	200	175	175	175	175	# 2 - 4/0	# 4 - 300	# 4 - 300
	460	60	119	150	125	125	125	125	# 6 - 1/0	# 2 - 4/0	# 2 - 4/0
	575	60	95	150	100	110	100	110	# 6 - 1/0	# 2 - 4/0	# 14 - 1/0
0064E_	200	60	306	400	350	350	350	350	# 4 - 500	250 - 500	250 - 500
	230	60	284	400	300	300	300	300	# 4 - 500	250 - 500	250 - 500
	380	60	175	200	200	200	200	200	# 2 - 4/0	# 4 - 300	# 4 - 300
	460	60	136	150	150	150	150	150	# 2 - 4/0	# 2 - 4/0	# 2 - 4/0
	575	60	109	150	125	125	125	125	# 6 - 1/0	# 2 - 4/0	# 2 - 4/0
0070E_	200	60	357	400	400	400	400	400	500 - (2) 4/0	250 - 500	250 - 500
	230	60	332	400	350	350	350	350	# 4 - 500	250 - 500	250 - 500
	380	60	201	250	225	225	225	225	1/0 - 300	# 4 - 300	# 4 - 300
	460	60	159	200	175	175	175	175	# 2 - 4/0	# 4 - 300	# 4 - 300
	575	60	127	150	150	150	150	150	# 2 - 4/0	# 2 - 4/0	# 2 - 4/0
0074E_	200	60	376	600	400	400	400	400	(2) # 4 - (2) 500	(2) 250 - (2) 500	250 - 500
	230	60	349	400	400	400	400	400	500 - (2) 4/0	250 - 500	250 - 500
	380	60	207	250	225	225	225	225	1/0 - 300	# 6 - 350	# 4 - 300
	460	60	167	200	175	175	175	175	# 2 - 4/0	# 4 - 300	# 4 - 300
	575	60	134	150	150	150	150	150	# 2 - 4/0	# 2 - 4/0	# 2 - 4/0
0080E_	200	60	399	600	450	450	450	450	(2)#4-(2)500	(2)250-(2)500	(2)250-(2)500
	230	60	371	600	400	400	400	400	(2) # 4 - (2) 500	250 - 500	250 - 500
	380	60	216	250	225	225	225	225	1/0 - 300	# 6 - 350	#4 - 300
	460	60	177	200	200	200	200	200	# 2 - 4/0	#4 - 300	#4 - 300
	575	60	142	200	150	150	150	150	# 2 - 4/0	# 6 - 350	# 2 - 4/0

See Notes and Legend on page 19.

SYSTEM #1 COMPRESSOR & FAN								SYSTEM #2 COMPRESSOR & FAN							
COMPR. #1		COMPR. #2		COMPR. #3		FANS		COMPR. #1		COMPR. #2		COMPR. #3		FANS	
RLA	LRA	RLA	LRA	RLA	LRA	QTY	FLA (EA)	RLA	LRA	RLA	LRA	RLA	LRA	QTY	FLA (EA)
32.9	265	32.9	265	—	—	2	8.2	32.9	265	32.9	265	—	—	2	8.2
30.5	265	30.5	265	—	—	2	7.8	30.5	265	30.5	265	—	—	2	7.8
19.4	155	19.4	155	—	—	2	4.8	19.4	155	19.4	155	—	—	2	4.8
14.5	120	14.5	120	—	—	2	3.8	14.5	120	14.5	120	—	—	2	3.8
11.6	80	11.6	80	—	—	2	3.1	11.6	80	11.6	80	—	—	2	3.1
50.2	298	50.2	298	—	—	2	8.2	32.9	265	32.9	265	—	—	2	8.2
46.5	298	46.5	298	—	—	2	7.8	30.5	265	30.5	265	—	—	2	7.8
28.1	235	28.1	235	—	—	2	4.8	19.4	155	19.4	155	—	—	2	4.8
22.1	170	22.1	170	—	—	2	3.8	14.5	120	14.5	120	—	—	2	3.8
17.7	140	17.7	140	—	—	2	3.1	11.6	80	11.6	80	—	—	2	3.1
50.2	298	50.2	298	—	—	2	8.2	50.2	298	50.2	298	—	—	2	8.2
46.5	298	46.5	298	—	—	2	7.8	46.5	298	46.5	298	—	—	2	7.8
28.1	235	28.1	235	—	—	2	4.8	28.1	235	28.1	235	—	—	2	4.8
22.1	170	22.1	170	—	—	2	3.8	22.1	170	22.1	170	—	—	2	3.8
17.7	140	17.7	140	—	—	2	3.1	17.7	140	17.7	140	—	—	2	3.1
57.4	420	57.4	420	—	—	2	8.2	49.5	298	49.5	298	—	—	2	8.2
53.1	420	53.1	420	—	—	2	7.8	45.9	298	45.9	298	—	—	2	7.8
30.8	235	30.8	235	—	—	2	4.8	27.8	235	27.8	235	—	—	2	4.8
25.3	175	25.3	175	—	—	2	3.8	21.8	170	21.8	170	—	—	2	3.8
20.2	140	20.2	140	—	—	2	3.1	17.5	140	17.5	140	—	—	2	3.1
55.0	420	55.0	420	—	—	2	8.2	55.0	420	55.0	420	—	—	2	8.2
50.9	420	50.9	420	—	—	2	7.8	50.9	420	50.9	420	—	—	2	7.8
29.6	235	29.6	235	—	—	2	4.8	29.6	235	29.6	235	—	—	2	4.8
24.2	175	24.2	175	—	—	2	3.8	24.2	175	24.2	175	—	—	2	3.8
19.4	140	19.4	140	—	—	2	3.1	19.4	140	19.4	140	—	—	2	3.1
52.4	298	52.4	298	52.4	298	2	8.2	34.2	265	34.2	265	34.2	265	2	8.2
48.6	298	48.6	298	48.6	298	2	7.8	31.6	265	31.6	265	31.6	265	2	7.8
29.3	235	29.3	235	29.3	235	2	4.8	20.2	155	20.2	155	20.2	155	2	4.8
23.1	170	23.1	170	23.1	170	2	3.8	15.1	120	15.1	120	15.1	120	2	3.8
18.5	140	18.5	140	18.5	140	2	3.1	12.0	80	12.0	80	12.0	80	2	3.1
51.8	298	51.8	298	51.8	298	2	8.2	51.8	298	51.8	298	51.8	298	2	8.2
48.0	298	48.0	298	48	298	2	7.8	48.0	298	48.0	298	48.0	298	2	7.8
29.0	235	29.0	235	29	235	2	4.8	29.0	235	29.0	235	29.0	235	2	4.8
22.9	170	22.9	170	22.9	170	2	3.8	22.9	170	22.9	170	22.9	170	2	3.8
18.3	140	18.3	140	18.3	140	2	3.1	18.3	140	18.3	140	18.3	140	2	3.1
58.9	420	58.9	420	58.9	420	2	8.2	50.5	298	50.5	298	50.5	298	2	8.2
54.5	420	54.5	420	54.5	420	2	7.8	46.8	298	46.8	298	46.8	298	2	7.8
31.6	235	31.6	235	31.6	235	2	4.8	28.3	235	28.3	235	28.3	235	2	4.8
26.0	175	26.0	175	26	175	2	3.8	22.3	170	22.3	170	22.3	170	2	3.8
20.8	140	20.8	140	20.8	140	2	3.1	17.8	140	17.8	140	17.8	140	2	3.1
58.6	420	58.6	420	58.6	420	2	8.2	58.6	420	58.6	420	58.6	420	2	8.2
54.2	420	54.2	420	54.2	420	2	7.8	54.2	420	54.2	420	54.2	420	2	7.8
31.5	235	31.5	235	31.5	235	2	4.8	31.5	235	31.5	235	31.5	235	2	4.8
25.8	175	25.8	175	25.8	175	2	3.8	25.8	175	25.8	175	25.8	175	2	3.8
20.7	140	20.7	140	20.7	140	2	3.1	20.7	140	20.7	140	20.7	140	2	3.1

ELECTRICAL DATA – MULTIPLE POINT POWER SUPPLY CONNECTIONS – YCAL0090E_ - YCAL0124E_

Two Field Provided Power Supply Circuits to the chiller. Field connections to Factory Provided Terminal Blocks (standard), Non-Fused Disconnect Switches (optional), or Individual System Circuit Breakers (optional) per electrical system

TABLE 5 – MULTIPLE POINT POWER SUPPLY CONNECTIONS

MODEL YCAL	VOLT	SYSTEM #1 FIELD SUPPLIED WIRING								
		MCA ¹	MIN N/F DISC SW ²	D.E. FUSE		CKT. BKR. ⁵		INCOMING (LUGS) WIRE RANGE ⁶		
				MIN ³	MAX ⁴	MIN	MAX	TERMINAL BLOCK (std)	NF DISC. SWITCHES (opt)	CIR BREAKERS (opt)
0090	200	251	400	300	350	300	350	# 6 - 400	(1 or 2) 3/0 - 500	(1 or 2) 3/0 - 500
	230	233	250	300	300	300	300	# 6 - 400	(1) # 6 - 350	(1 or 2) 3/0 - 500
	380	135	150	150	175	150	175	# 14 - 2/0	(1) # 6 - 350	(1) # 6 - 350
	460	111	150	125	150	125	150	# 14 - 2/0	(1) # 6 - 350	(1) # 3 - 3/0
	575	89	100	100	110	100	110	# 14 - 2/0	(1) # 6 - 350	(1) # 10 - 1/0
0094	200	251	400	300	350	300	350	# 6 - 400	(1 or 2) 3/0 - 500	(1 or 2) 3/0 - 500
	230	233	250	300	300	300	300	# 6 - 400	(1) # 6 - 350	(1 or 2) 3/0 - 500
	380	135	150	150	175	150	175	# 14 - 2/0	(1) # 6 - 350	(1) # 6 - 350
	460	111	150	125	150	125	150	# 14 - 2/0	(1) # 6 - 350	(1) # 3 - 3/0
	575	89	100	100	110	100	110	# 14 - 2/0	(1) # 6 - 350	(1) # 10 - 1/0
0104	200	274	400	300	300	300	300	(2) # 4 - 500	(1 or 2) 3/0 - 500	(1 or 2) 3/0 - 500
	230	254	400	300	300	300	300	(2) # 4 - 500	(1 or 2) 3/0 - 500	(1 or 2) 3/0 - 500
	380	148	200	175	175	175	175	# 14 - 2/0	(1) # 6 - 350	(1) # 3 - 3/0
	460	122	150	150	150	150	150	# 14 - 2/0	(1) # 6 - 350	(1) # 10 - 1/0
	575	98	150	110	110	110	110	# 14 - 2/0	(1) # 10 - 1/0	(1) # 10 - 1/0
0114	200	274	400	300	300	300	300	(2) # 4 - 500	(1 or 2) 3/0 - 500	(1 or 2) 3/0 - 500
	230	254	400	300	300	300	300	(2) # 4 - 500	(1 or 2) 3/0 - 500	(1 or 2) 3/0 - 500
	380	148	200	175	175	175	175	# 14 - 2/0	(1) # 6 - 350	(1) # 6 - 350
	460	122	150	150	150	150	150	# 14 - 2/0	(1) # 6 - 350	(1) # 6 - 350
	575	98	150	110	110	110	110	# 14 - 2/0	(1) # 6 - 350	(1) # 3 - 3/0
0124	200	359	400	400	450	400	450	(2) # 4 - 500	(1 or 2) 3/0 - 500	(1 or 2) 3/0 - 500
	230	333	400	400	400	400	400	(2) # 4 - 500	(1 or 2) 3/0 - 500	(1 or 2) 3/0 - 500
	380	194	250	225	225	225	225	# 6 - 400	(1) # 6 - 350	(1) # 6 - 350
	460	159	200	175	200	175	200	# 6 - 400	(1) # 6 - 350	(1) # 6 - 350
	575	128	150	150	150	150	150	# 14 - 2/0	(1) # 6 - 350	(1) # 6 - 350

MODEL YCAL	VOLT	SYSTEM #2 FIELD SUPPLIED WIRING								
		MCA ¹	MIN N/F DISC SW ²	D.E. FUSE		CKT. BKR. ⁵		INCOMING (LUGS) WIRE RANGE ⁶		
				MIN ³	MAX ⁴	MIN	MAX	TERMINAL BLOCK (std)	NF DISC. SWITCHES (opt)	CIR BREAKERS (opt)
0090	200	191	200	225	250	225	250	# 6 - 400	(1) # 6 - 350	(1) # 6 - 350
	230	178	200	200	225	200	225	# 6 - 400	(1) # 6 - 350	(1) # 6 - 350
	380	104	150	125	125	125	125	# 14 - 2/0	(1) # 6 - 350	(1) # 3 - 3/0
	460	85	100	100	110	100	110	# 14 - 2/0	(1) # 10 - 1/0	(1) # 10 - 1/0
	575	68	100	80	90	80	90	# 14 - 2/0	(1) # 10 - 1/0	(1) # 10 - 1/0
0094	200	251	400	300	350	300	350	# 6 - 400	(1 or 2) 3/0 - 500	(1 or 2) 3/0 - 500
	230	233	250	300	300	300	300	# 6 - 400	(1) # 6 - 350	(1 or 2) 3/0 - 500
	380	135	150	150	175	150	175	# 14 - 2/0	(1) # 6 - 350	(1) # 6 - 350
	460	111	150	125	150	125	150	# 14 - 2/0	(1) # 6 - 350	(1) # 3 - 3/0
	575	89	100	100	110	100	110	# 14 - 2/0	(1) # 6 - 350	(1) # 10 - 1/0
0104	200	259	400	300	350	300	350	# 6 - 400	(1 or 2) 3/0 - 500	(1 or 2) 3/0 - 500
	230	241	250	300	300	300	300	# 6 - 400	(1) # 6 - 350	(1 or 2) 3/0 - 500
	380	140	150	175	175	175	175	# 14 - 2/0	(1) # 6 - 350	(1) # 6 - 350
	460	115	150	150	150	150	150	# 14 - 2/0	(1) # 6 - 350	(1) # 6 - 350
	575	92	100	110	125	110	125	# 14 - 2/0	(1) # 6 - 350	(1) # 3 - 3/0
0114	200	274	400	300	300	300	300	(2) # 4 - 500	(1 or 2) 3/0 - 500	(1 or 2) 3/0 - 500
	230	254	400	300	300	300	300	(2) # 4 - 500	(1 or 2) 3/0 - 500	(1 or 2) 3/0 - 500
	380	148	200	175	175	175	175	# 14 - 2/0	(1) # 6 - 350	(1) # 6 - 350
	460	122	150	150	150	150	150	# 14 - 2/0	(1) # 6 - 350	(1) # 6 - 350
	575	98	150	110	110	110	110	# 14 - 2/0	(1) # 6 - 350	(1) # 3 - 3/0
0124	200	374	400	300	300	300	300	(2) # 4 - 500	(1 or 2) 3/0 - 500	(1 or 2) 3/0 - 500
	230	354	400	300	300	300	300	(2) # 4 - 500	(1 or 2) 3/0 - 500	(1 or 2) 3/0 - 500
	380	148	200	175	175	175	175	# 14 - 2/0	(1) # 6 - 350	(1) # 6 - 350
	460	122	150	150	150	150	150	# 14 - 2/0	(1) # 6 - 350	(1) # 6 - 350
	575	98	150	110	110	110	110	# 14 - 2/0	(1) # 6 - 350	(1) # 3 - 3/0

See Notes and Legend on page 19.

SYSTEM #1 COMPRESSOR & FAN							
COMPR. #1		COMPR. #2		COMPR. #3		FANS	
RLA	LRA	RLA	LRA	RLA	LRA	QTY	FLA(EA)
100.2	550	100.2	550	—	—	3	8.2
92.8	550	92.8	550	—	—	3	7.8
53.5	305	53.5	305	—	—	3	4.8
44.2	270	44.2	270	—	—	3	3.8
35.4	210	35.4	210	—	—	3	3.1
100.2	550	100.2	550	—	—	3	8.2
92.8	550	92.8	550	—	—	3	7.8
53.5	305	53.5	305	—	—	3	4.8
44.2	270	44.2	270	—	—	3	3.8
35.4	210	35.4	210	—	—	3	3.1
73.9	450	73.9	450	73.9	450	4	8.2
68.5	450	68.5	450	68.5	450	4	7.8
39.5	260	39.5	260	39.5	260	4	4.8
32.6	215	32.6	215	32.6	215	4	3.8
26.1	180	26.1	180	26.1	180	4	3.1
73.9	450	73.9	450	73.9	450	4	8.2
68.5	450	68.5	450	68.5	450	4	7.8
39.5	260	39.5	260	39.5	260	4	4.8
32.6	215	32.6	215	32.6	215	4	3.8
26.1	180	26.1	180	26.1	180	4	3.1
100.2	550	100.2	550	100.2	550	4	8.2
92.8	550	92.8	550	92.8	550	4	7.8
53.5	305	53.5	305	53.5	305	4	4.8
44.2	270	44.2	270	44.2	270	4	3.8
35.4	210	35.4	210	35.4	210	4	3.1

SYSTEM #2 COMPRESSOR & FAN							
COMPR. #1		COMPR. #2		COMPR. #3		FANS	
RLA	LRA	RLA	LRA	RLA	LRA	QTY	FLA(EA)
73.9	450	73.9	450	—	—	3	8.2
68.5	450	68.5	450	—	—	3	7.8
39.5	260	39.5	260	—	—	3	4.8
32.6	215	32.6	215	—	—	3	3.8
26.1	180	26.1	180	—	—	3	3.1
100.2	550	100.2	550	—	—	3	8.2
92.8	550	92.8	550	—	—	3	7.8
53.5	305	53.5	305	—	—	3	4.8
44.2	270	44.2	270	—	—	3	3.8
35.4	210	35.4	210	—	—	3	3.1
100.2	550	100.2	550	—	—	4	8.2
92.8	550	92.8	550	—	—	4	7.8
53.5	305	53.5	305	—	—	4	4.8
44.2	270	44.2	270	—	—	4	3.8
35.4	210	35.4	210	—	—	4	3.1
73.9	450	73.9	450	73.9	450	4	8.2
68.5	450	68.5	450	68.5	450	4	7.8
39.5	260	39.5	260	39.5	260	4	4.8
32.6	215	32.6	215	32.6	215	4	3.8
26.1	180	26.1	180	26.1	180	4	3.1
73.9	450	73.9	450	73.9	450	4	8.2
68.5	450	68.5	450	68.5	450	4	7.8
39.5	260	39.5	260	39.5	260	4	4.8
32.6	215	32.6	215	32.6	215	4	3.8
26.1	180	26.1	180	26.1	180	4	3.1

**ELECTRICAL DATA – SINGLE POINT POWER SUPPLY CONNECTIONS WITH INDIVIDUAL SYSTEM
CIRCUIT BREAKERS – YCAL0090E_ - YCAL0124E_**

One Field Provided Power Supply Circuit to the chiller. Field connections to Factory Provided Terminal Block (optional) or Non-Fused Disconnect Switch (optional). Includes Individual Branch Circuit Protection (Breakers) per electrical system

**TABLE 6 – SINGLE POINT POWER SUPPLY CONNECTIONS WITH INDIVIDUAL SYSTEM
CIRCUIT BREAKERS**

MODEL YCAL	VOLT	HZ	SINGLE POINT FIELD SUPPLIED WIRING							
			MCA ¹	MIN N/F DISC SW ²	D.E. FUSE		CKT. BKR. ⁵		INCOMING (LUGS) WIRE RANGE ⁶	
					MIN ³	MAX ⁴	MIN	MAX	TERMINAL BLOCK (opt)	NF DISC. SWITCH (opt)
0090	200	60	423	600	450	500	450	500	(2) # 4 - 500	(1 or 2) 3/0 - 500
	230	60	393	600	450	450	450	450	(2) # 4 - 500	(1 or 2) 3/0 - 500
	380	60	229	250	250	250	250	250	(2) # 4 - 500	(1) # 6 - 350
	460	60	188	250	250	200	250	200	# 6 - 400	(1) # 6 - 350
	575	60	151	200	200	175	200	175	# 14 - 2/0	(1) # 6 - 350
0094	200	60	476	600	600	600	600	600	(2) # 4 - 500	(1 or 2) 3/0 - 500
	230	60	442	600	500	500	500	500	(2) # 4 - 500	(1 or 2) 3/0 - 500
	380	60	257	400	300	300	300	300	(2) # 4 - 500	(1 or 2) 3/0 - 500
	460	60	211	250	225	250	225	250	# 6 - 400	(1) # 6 - 350
	575	60	169	200	200	200	200	200	# 6 - 400	(1) # 6 - 350
0104	200	60	513	600	600	600	600	600	(2) # 4 - 500	(1 or 2) 3/0 - 500
	230	60	477	600	500	500	500	500	(2) # 4 - 500	(1 or 2) 3/0 - 500
	380	60	278	400	300	300	300	300	(2) # 4 - 500	(1 or 2) 3/0 - 500
	460	60	228	250	250	250	250	250	# 6 - 400	(1) # 6 - 350
	575	60	183	200	200	200	200	200	# 6 - 400	(1) # 6 - 350
0114	200	60	528	600	600	600	600	600	(2) # 4 - 500	(1 or 2) 3/0 - 500
	230	60	491	600	600	600	600	600	(2) # 4 - 500	(1 or 2) 3/0 - 500
	380	60	286	400	300	300	300	300	(2) # 4 - 500	(1 or 2) 3/0 - 500
	460	60	235	400	250	250	250	250	# 6 - 400	(1 or 2) 3/0 - 500
	575	60	188	250	200	200	200	200	# 6 - 400	(1) # 6 - 350
0124	200	60	607	800	700	700	700	700	(2) # 4 - 500	(1 or 2) 3/0 - 500
	230	60	564	800	600	600	600	600	(2) # 4 - 500	(1 or 2) 3/0 - 500
	380	60	328	400	350	350	350	350	(2) # 4 - 500	(1 or 2) 3/0 - 500
	460	60	269	400	300	300	300	300	# 6 - 400	(1 or 2) 3/0 - 500
	575	60	216	250	250	250	250	250	# 6 - 400	(1) # 6 - 350

See Notes and Legend on page 19.

SYSTEM#1 COMPRESSOR & FAN								SYSTEM#2 COMPRESSOR & FAN							
COMPR. #1		COMPR. #2		COMPR. #3		FANS		COMPR. #1		COMPR. #2		COMPR. #3		FANS	
RLA	LRA	RLA	LRA	RLA	LRA	QTY	FLA(EA)	RLA	LRA	RLA	LRA	RLA	LRA	QTY	FLA(EA)
100.2	550	100.2	550	—	—	3	8.2	73.9	450	73.9	450	—	—	3	8.2
92.8	550	92.8	550	—	—	3	7.8	68.5	450	68.5	450	—	—	3	7.8
53.5	305	53.5	305	—	—	3	4.8	39.5	260	39.5	260	—	—	3	4.8
44.2	270	44.2	270	—	—	3	3.8	32.6	215	32.6	215	—	—	3	3.8
35.4	210	35.4	210	—	—	3	3.1	26.1	180	26.1	180	—	—	3	3.1
100.2	550	100.2	550	—	—	3	8.2	100.2	550	100.2	550	—	—	3	8.2
92.8	550	92.8	550	—	—	3	7.8	92.8	550	92.8	550	—	—	3	7.8
53.5	305	53.5	305	—	—	3	4.8	53.5	305	53.5	305	—	—	3	4.8
44.2	270	44.2	270	—	—	3	3.8	44.2	270	44.2	270	—	—	3	3.8
35.4	210	35.4	210	—	—	3	3.1	35.4	210	35.4	210	—	—	3	3.1
73.9	450	73.9	450	73.9	450	4	8.2	100.2	550	100.2	550	—	—	4	8.2
68.5	450	68.5	450	68.5	450	4	7.8	92.8	550	92.8	550	—	—	4	7.8
39.5	260	39.5	260	39.5	260	4	4.8	53.5	305	53.5	305	—	—	4	4.8
32.6	215	32.6	215	32.6	215	4	3.8	44.2	270	44.2	270	—	—	4	3.8
26.1	180	26.1	180	26.1	180	4	3.1	35.4	210	35.4	210	—	—	4	3.1
73.9	450	73.9	450	73.9	450	4	8.2	73.9	450	73.9	450	73.9	450	4	8.2
68.5	450	68.5	450	68.5	450	4	7.8	68.5	450	68.5	450	68.5	450	4	7.8
39.5	260	39.5	260	39.5	260	4	4.8	39.5	260	39.5	260	39.5	260	4	4.8
32.6	215	32.6	215	32.6	215	4	3.8	32.6	215	32.6	215	32.6	215	4	3.8
26.1	180	26.1	180	26.1	180	4	3.1	26.1	180	26.1	180	26.1	180	4	3.1
100.2	550	100.2	550	100.2	550	4	8.2	73.9	450	73.9	450	73.9	450	4	8.2
92.8	550	92.8	550	92.8	550	4	7.8	68.5	450	68.5	450	68.5	450	4	7.8
53.5	305	53.5	305	53.5	305	4	4.8	39.5	260	39.5	260	39.5	260	4	4.8
44.2	270	44.2	270	44.2	270	4	3.8	32.6	215	32.6	215	32.6	215	4	3.8
35.4	210	35.4	210	35.4	210	4	3.1	26.1	180	26.1	180	26.1	180	4	3.1

OPERATIONAL LIMITATIONS (ENGLISH)

TABLE 7 – TEMPERATURES AND FLOWS

YCAL	LEAVING WATER TEMPERATURE (°F)		COOLER FLOW (GPM ³)		AIR ON CONDENSER (°F)	
	MIN ¹	MAX ²	MIN	MAX	MIN ⁴	MAX ⁵
0014E_	40	55	25	60	0	125
0020E_	40	55	25	60	0	125
0024E_	40	55	30	70	0	125
0030E_	40	55	35	170	0	125
0034E_	40	55	60	170	0	125
0040E_	40	55	60	300	0	125
0042E_	40	55	60	300	0	125
0044E_	40	55	60	300	0	125
0050E_	40	55	60	300	0	125
0060E_	40	55	60	300	0	125
0064E_	40	55	100	300	0	125
0070E_	40	55	100	350	0	125
0074E_	40	55	100	350	0	125
0080E_	40	55	100	385	0	125
0090E_	40	55	125	525	0	125
0094E_	40	55	138	525	0	125
0104E_	40	55	150	625	0	125
0114E_	40	55	165	625	0	125
0124E_	40	55	180	625	0	125

VOLTAGE LIMITATIONS

The following voltage limitations are absolute and operation beyond these limitations may cause serious damage to the compressor.



Excessive flow will cause damage to the cooler. Do not exceed max. cooler flow. Special care should be taken when multiple chillers are fed by a single pump.

TABLE 8 – VOLTAGE LIMITATIONS

UNIT POWER	MIN.	MAX.
200-3-60	180	220
230-3-60	207	253
380-3-60	355	415
460-3-60	414	506
575-3-60	517	633

NOTES:

1. For leaving brine temperature below 40°F (4.4°C), contact your nearest YORK Office for application requirements.
2. For leaving water temperature higher than 55°F (12.8°C), contact the nearest YORK Office for application guidelines.
3. The evaporator is protected against freezing to -20°F (-28.8°C) with an electric heater as standard.
4. For operation at temperatures below 25°F (-3.9°C), the optional Low Ambient Kit will need to be installed on the system (for YCAL0014-0080 models only).
5. For operation at temperatures above 115°F (46.1°C), the optional High Ambient Kit will need to be installed on the system.

OPERATIONAL LIMITATIONS (ENGLISH)

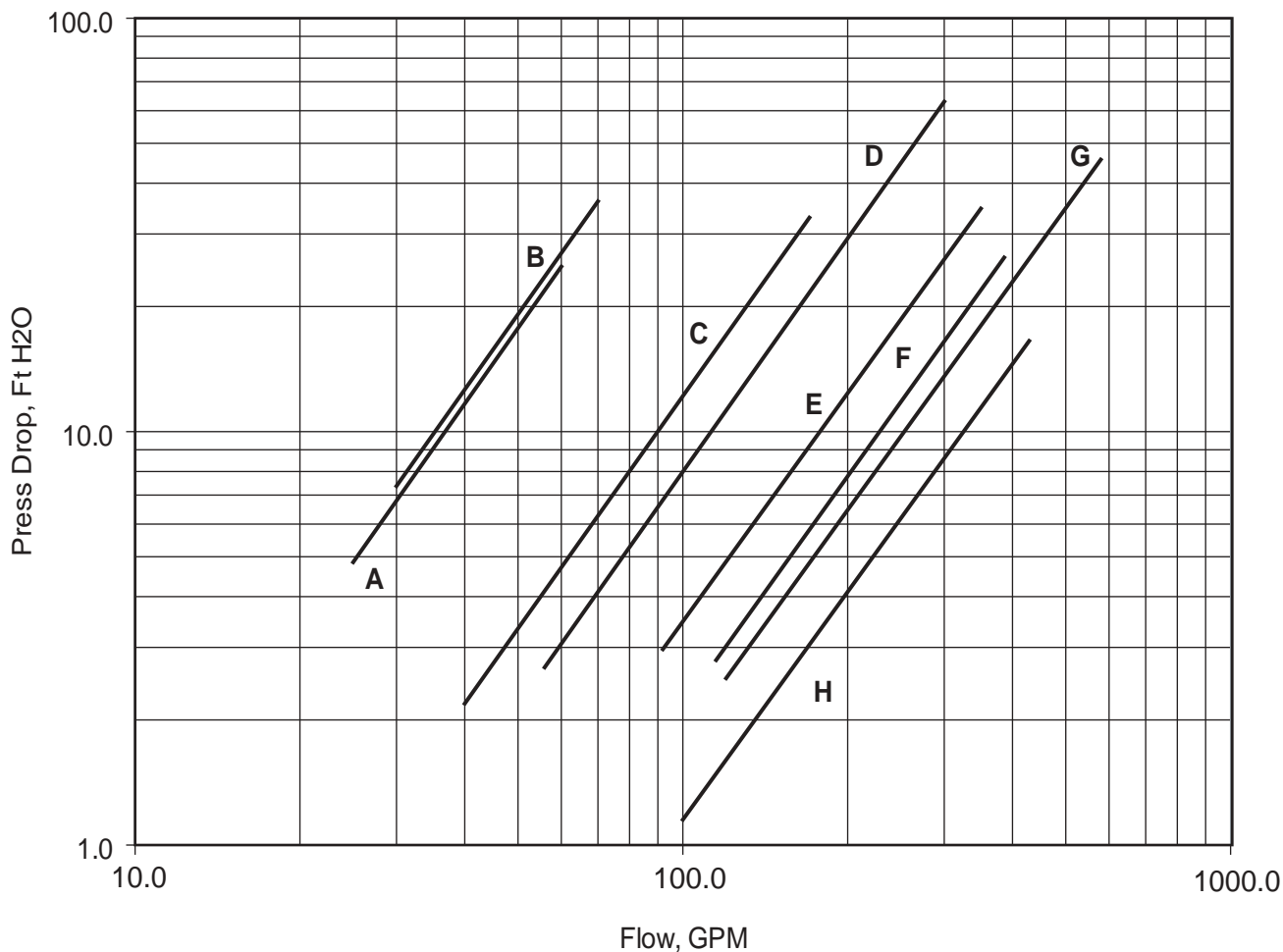

LD07748

TABLE 9 – COOLER PRESSURE DROP CURVES

MODEL YCAL	COOLER CURVE
0014E_, 0020E_	A
0024E_	B
0030E_, 0034E_	C
0040E_, 0042E_, 0044E_, 0050E_, 0060E_	D
0064E_, 0070E_, 0074E_	E
0080E_	F
0090E_, 0094E_	G
0104E_, 0114E_, 0124E	H

TABLE 10 – ETHYLENE GLYCOL CORRECTION FACTORS

% WT ETHYLENE GLYCOL	FACTORS				FREEZE POINT (°F)
	TONS	COMPR. kW	DELTA P	GPM/ °F/ TON	
10	.994	.997	1.03	24.1	26
20	.986	.993	1.06	24.9	16
30	.979	.990	1.09	25.9	5
40	.970	.985	1.13	27.3	-10
50	.959	.980	1.16	29.0	-32

OPERATIONAL LIMITATIONS (METRIC)

TABLE 11 – TEMPERATURES AND FLOWS

YCAL	LEAVING WATER TEMPERATURE (°C)		COOLER FLOW (l/s ³)		AIR ON CONDENSER (°C)	
	MIN ¹	MAX ²	MIN	MAX	MIN ⁴	MAX ⁵
0014E_	4.4	12.8	1.6	3.8	-17.7	51.7
0020E_	4.4	12.8	1.6	3.8	-17.7	51.7
0024E_	4.4	12.8	1.9	4.4	-17.7	51.7
0030E_	4.4	12.8	2.2	10.7	-17.7	51.7
0034E_	4.4	12.8	3.8	10.7	-17.7	51.7
0040E_	4.4	12.8	3.8	18.9	-17.7	51.7
0042E_	4.4	12.8	3.8	18.9	-17.7	51.7
0044E_	4.4	12.8	3.8	18.9	-17.7	51.7
0050E_	4.4	12.8	3.8	18.9	-17.7	51.7
0060E_	4.4	12.8	3.8	18.9	-17.7	51.7
0064E_	4.4	12.8	6.3	22.1	-17.7	51.7
0070E_	4.4	12.8	6.3	22.1	-17.7	51.7
0074E_	4.4	12.8	6.3	22.1	-17.7	51.7
0080E_	4.4	12.8	6.3	24.3	-17.7	51.7
0090E_	4.4	12.8	7.9	33.1	-17.7	51.7
0094E_	4.4	12.8	8.7	33.1	-17.7	51.7
0104E_	4.4	12.8	9.5	39.4	-17.7	51.7
0114E_	4.4	12.8	10.4	39.4	-17.7	51.7
0124E_	4.4	12.8	11.4	39.4	-17.7	51.7

VOLTAGE LIMITATIONS

The following voltage limitations are absolute and operation beyond these limitations may cause serious damage to the compressor.



Excessive flow will cause damage to the cooler. Do not exceed max. cooler flow. Special care should be taken when multiple chillers are fed by a single pump.

TABLE 12 – VOLTAGE LIMITATIONS

UNIT POWER	MIN.	MAX.
200-3-60	180	220
230-3-60	207	253
380-3-60	355	415
460-3-60	414	506
575-3-60	517	633

NOTES:

1. For leaving brine temperature below 40°F (4.4°C), contact your nearest YORK Office for application requirements.
2. For leaving water temperature higher than 55°F (12.8°C), contact the nearest YORK Office for application guidelines.
3. The evaporator is protected against freezing to -20°F (-28.8°C) with an electric heater as standard.
4. For operation at temperatures below 25°F (-3.9°C), the optional Low Ambient Kit will need to be installed on the system (for YCAL0014-0080 models only).
5. For operation at temperatures above 115°F (46.1°C), the optional High Ambient Kit will need to be installed on the system.

OPERATIONAL LIMITATIONS (METRIC)

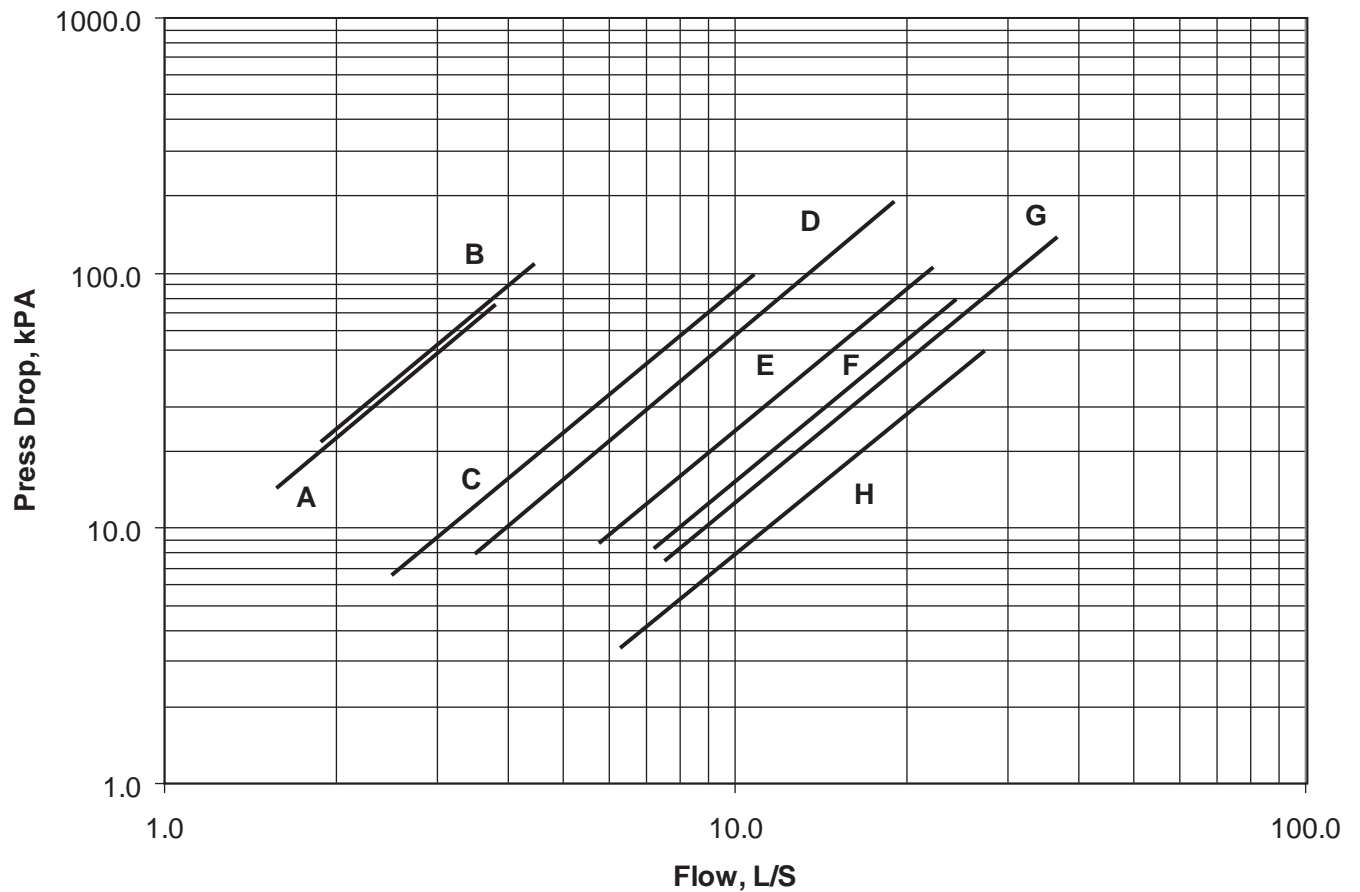

1

LD07749

TABLE 13 – COOLER PRESSURE DROP CURVES

MODEL YCAL	COOLER CURVE
0014E_, 0020E_	A
0024E_	B
0030E_, 0034E_	C
0040E_, 0042E_, 0044E_, 0050E_, 0060E_	D
0064E_, 0070E_, 0074E_	E
0080E_	F
0090E_, 0094E_	G
0104E_, 0114E_, 0124E	H

TABLE 14 – ETHYLENE GLYCOL CORRECTION FACTORS

% WT ETHYLENE GLYCOL	FACTORS				FREEZE POINT (°F)
	TONS	COMPR. kW	DELTA P	GPM/ °F/ TON	
10	.994	.997	1.03	24.1	26
20	.986	.993	1.06	24.9	16
30	.979	.990	1.09	25.9	5
40	.970	.985	1.13	27.3	-10
50	.959	.980	1.16	29.0	-32

PHYSICAL DATA (ENGLISH)
YCAL0014E_ - YCAL0124E_

TABLE 15 – PHYSICAL DATA (ENGLISH)

	Model Number YCAL							
	0014	0020	0024	0030	0034	0040	0042	0044
General Unit Data								
Nominal Tons, R-22	13.6	18.1	23.7	27.6	34.8	38.7	43.3	48.2
Nominal Tons, R-407C	12.7	17.1	22.5	26.3	33.7	37.0	41.5	46.0
Number of Refrigerant Circuits	1	1	1	1	1	2	2	2
Refrigerant Charge								
R-22, ckt1 / ckt2, lbs	32	38	58	65	69	45/45	51/48	54/54
R-407C, ckt1 / ckt2, lbs	32	38	58	65	69	45/45	51/48	52/52
Oil Charge, ckt1 / ckt2, gallons	1.7	1.7	2.1	3.5	3.2	2.0/2.0	2.1/2.0	2.1/2.1
Shipping Weight								
Aluminum Fin Coils, lbs	2143	2159	2345	2540	2770	3910	4184	4039
Copper Fin Coils, lbs	2315	2325	2536	2829	3120	4313	4543	4413
Operating Weight								
Aluminum Fin Coils, lbs	2220	2236	2428	2643	2873	4153	4427	4282
Copper Fin Coils, lbs	2392	2402	2619	2932	3223	4556	4786	4656
Compressors, scroll type								
Compressors per circuit	2	2	2	2	3	2	2	2
Compressors per unit	2	2	2	2	3	4	4	4
Nominal Tons per compressor	7.5	10	13	15	13	10/10	13/10	13/13
Condenser								
Total Face Area ft ²	47.2	47.2	66.1	66.1	66.1	128.0	128.0	128.0
Number of Rows	2	2	2	3	3	2	2	2
Fins per Inch	13	13	13	13	13	13	13	13
Condenser Fans								
Number of Fans total	2	2	2	2	2	4	4	4
Fan hp/kw	2 / 1.4	2 / 1.4	2 / 1.4	2 / 1.4	2 / 1.4	2 / 1.4	2 / 1.4	2 / 1.4
Fan RPM	1140	1140	1140	1140	1140	1140	1140	1140
Number of Blades	3	3	3	3	3	3	3	3
Total Chiller CFM	16257	16257	23500	23500	23500	47360	47360	47360
Evaporator, Direct Expansion								
Diameter x Length	8"x6'	8"x6'	8"x6.5'	8"x7'	8"x7'	10"x8'	10"x8'	10"x8'
Water Volume, gallons	9.2	9.2	10.0	12.3	12.3	29.1	29.1	29.1
Maximum Water Side Pressure, PSIG	150	150	150	150	150	150	150	150
Maximum Refrigerant Side Pressure, PSIG	350	350	350	350	350	350	350	350
Minimum Chiller Water Flow Rate, gpm	25	25	30	35	60	60	60	60
Maximum Chiller Water Flow Rate, gpm	60	60	70	170	170	300	300	300
Water Connections, inches	3	3	3	4	4	6	6	6

PHYSICAL DATA (ENGLISH)

YCAL0014E_ - YCAL0124E_

0050	0060	0064	0070	0074	0080	0090	0094	0104	0114	0124
51.0	54.8	64.1	71.8	75.8	80.2	83.2	89.9	99.6	111.1	121.0
48.6	52.5	61.6	68.5	73.9	78.6	79.6	85.8	94.9	106.5	115.1
2	2	2	2	2	2	2	2	2	2	2
60/54	72/72	75/62	80/80	92/83	100/100	94/77	94/94	112/94	112/112	137/112
60/54	60/60	77/60	80/80	92/83	88/88	90/74	90/90	108/90	108/108	132/108
3.5/2.1	3.5/3.5	3.2/3.0	3.2/3.2	5.2/3.2	5.2/5.2	4.2/4.2	4.2/4.2	6.3/4.2	6.3/6.3	6.3/6.3
4117	4378	4695	5029	5053	5619	6558	6638	7443	8826	8850
4491	5078	5240	5430	5752	6435	7386	7466	8387	10092	10116
4360	4621	5039	5373	5397	5758	6981	7060	7923	9306	9330
4734	5321	5584	5774	6096	6574	7809	7888	8867	10572	10596
2	2	3	3	3	3	2	2	3/2	3	3
4	4	6	6	6	6	4	4	5	6	6
15/13	15/15	13/10	13/13	15/13	15/15	25/20	25/25	20/25	20/20	25/20
128.0	128.0	149.3	149.3	149.3	149.3	168.0	168.0	192.0	222.0	222.0
2	3	2	3	3	3	3	3	3	3	3
13	13	13	13	13	13	13	13	13	13	13
4	4	4	4	4	4	6	6	6	8	8
2 / 1.4	2 / 1.4	2 / 1.7	2 / 1.7	2 / 1.7	2 / 1.7	2/1.8	2/1.8	2/1.8	2/1.8	2/1.8
1140	1140	1140	1140	1140	1140	1140	1140	1140	1140	1140
3	3	3	3	3	3	3	3	3	3	3
47360	46080	55253	55253	54550	53760	79800	79800	85800	106400	106400
10"x8'	10"x8'	12"x8'	12"x8'	12"x8'	12"x8'	14"x8'	14"x8'	15"x8'	15"x8'	15"x8'
29.1	29.1	41.2	41.2	41.2	39.9	53.0	53.0	58.9	58.9	58.9
150	150	150	150	150	150	150	150	150	150	150
350	350	350	350	350	350	350	350	350	350	350
60	60	100	100	100	100	125	138	150	165	180
300	300	350	350	350	385	525	525	625	625	625
6	6	6	6	6	6	8	8	8	8	8

**PHYSICAL DATA (METRIC)
YCAL0014E_ - YCAL0124E_**

TABLE 16 – PHYSICAL DATA (METRIC)

	Model Number YCAL							
	0014	0020	0024	0030	0034	0040	0042	0044
General Unit Data								
Nominal kW, R-22	47.8	63.7	83.4	97.1	122.4	136.1	152.3	169.5
Nominal kW, R-407C	44.7	59.8	79.1	92.5	118.5	130.1	146.0	161.8
Number of Refrigerant Circuits	1	1	1	1	1	2	2	2
Refrigerant Charge								
R-22, ckt1 / ckt2, kg	15	17	24	30	31	21/21	23/22	25/25
R-407C, ckt1 / ckt2, kg	15	17	24	30	31	21/21	23/22	24/24
Oil Charge, ckt1 / ckt2, liters	6	6	8	13	12	8.0/8.0	8.0/8.0	8.0/8.0
Shipping Weight								
Aluminum Fin Coils, kg	972	979	1064	1152	1256	1774	1898	1832
Copper Fin Coils, kg	1050	1055	1150	1283	1415	1957	2061	2002
Operating Weight								
Aluminum Fin Coils, kg	1007	1014	1101	1199	1303	1884	2008	1942
Copper Fin Coils, kg	1085	1090	1188	1330	1462	2067	2171	2112
Compressors, scroll type								
Compressors per circuit	2	2	2	2	3	2	2	2
Compressors per unit	2	2	2	2	3	4	4	4
Nominal kWo per compressor	26	35	46	53	46	35/35	46/35	46/4
Condenser								
Total Face Area meters ²	4	4	6	6	6	12	12	12
Number of Rows	2	2	2	3	3	2	2	2
Fins per m	512	512	512	512	512	512	512	512
Condenser Fans								
Number of Fans total	2	2	2	2	2	4	4	4
Fan hp/kw	2 / 1.4	2 / 1.4	2 / 1.4	2 / 1.4	2 / 1.4	2 / 1.4	2 / 1.4	2 / 1.4
Fan RPM	1140	1140	1140	1140	1140	1140	1140	1140
Number of Blades	3	3	3	3	3	3	3	3
Total Chiller Airflow l/s	7672	7672	11091	11091	11091	22351	22351	22351
Evaporator, Direct Expansion								
Diameter x Length	203x1829	203x1830	203x1981	210x2134	210x2134	248x2438	248x2438	248x2438
Water Volume, liters	34.9	34.9	37.7	46.7	46.7	110.3	110.3	110.3
Maximum Water Side Pressure, bar	10	10	10	10	10	10	10	10
Maximum Refrigerant Side Pressure, bar	24	24	24	24	24	24	24	24
Minimum Chiller Water Flow Rate, l/s	1.6	1.6	1.9	2.2	3.8	3.8	3.8	3.8
Maximum Chiller Water Flow Rate, l/s	3.8	3.8	4.4	10.7	10.7	18.9	18.9	18.9
Water Connections, inches	3	3	3	4	4	6	6	6

PHYSICAL DATA (METRIC) YCAL0014E_ - YCAL0124E_

0050	0060	0064	0070	0074	0080	0090	0094	0104	0114	0124
179.4	192.7	225.4	252.5	266.6	282.1	292.6	316.2	350.3	390.7	425.6
170.9	184.6	216.6	240.9	259.9	276.4	280.0	301.8	333.8	374.6	404.8
2	2	2	2	2	2	2	2	2	2	2
27/25	33/33	34/28	34/34	42/38	46/46	43/35	43/43	51/43	51/51	62/51
27/25	27/27	35/37	35/35	42/38	40/40	41/34	41/41	49/41	49/49	60/49
13/8	13/13	12/11	12/12	20/12	20/20	16/16	16/16	24/16	24/24	24/24
1867	1986	2130	2281	2292	2549	2975	3011	3376	4003	4014
2037	2303	2377	2463	2609	2919	3350	3387	3804	4578	4589
1978	2096	2286	2437	2448	2612	3167	3202	3594	4221	4232
2147	2413	2533	2619	2765	2982	3542	3578	4022	4795	4806
2	2	3	3	3	3	2	2	3/2	3	3
4	4	6	6	6	6	4	4	5	6	6
53/46	53/53	46/35	46/46	53/46	53/53	88/70	88/88	70/88	70/70	88/70
12	12	14	14	14	14	16	16	18	21	21
2	3	2	2	3	3	3	3	3	3	3
512	512	512	512	512	512	512	512	512	512	512
4	4	4	4	4	4	6	6	6	8	8
2 / 1.4	2 / 1.4	2 / 1.7	2 / 1.7	2 / 1.7	2 / 1.7	2 / 1.8	2 / 1.8	2 / 1.8	2 / 1.8	2 / 1.8
1140	1140	1140	1140	1140	1140	1140	1140	1140	1140	1140
3	3	3	3	3	3	3	3	3	3	3
22351	21747	26076	26076	25744	25371	37660	37660	39784	50214	50214
248x2438	248x2438	309x2438	309x2438	309x2438	315x2438	356x2438	356x2438	381x2438	381x2438	381x2438
110.3	110.3	156.1	156.1	156.1	151.1	200.6	200.6	222.9	222.9	222.9
10	10	10	10	10	10	10	10	10	10	10
24	24	24	24	24	24	24	24	24	24	24
3.8	3.8	6.3	6.3	6.3	6.3	7.9	8.7	9.5	10.4	11.4
18.9	18.9	22.1	22.1	22.1	24.3	33.1	33.1	39.4	39.4	39.4
6	6	6	6	6	6	8	8	8	8	8

DIMENSIONS - YCAL0014-YCAL0020 (ENGLISH)

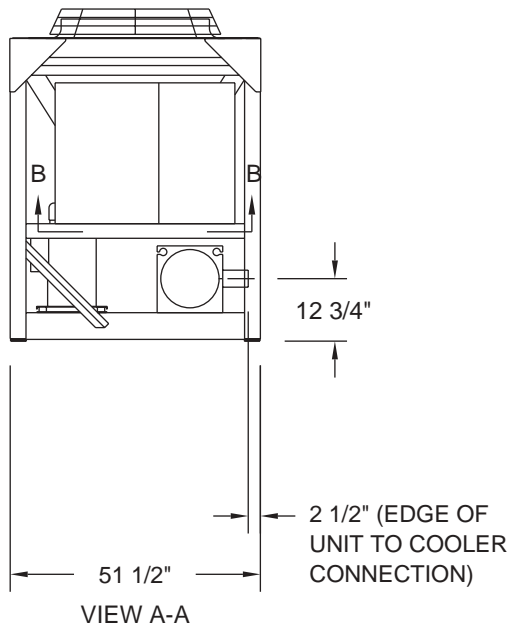
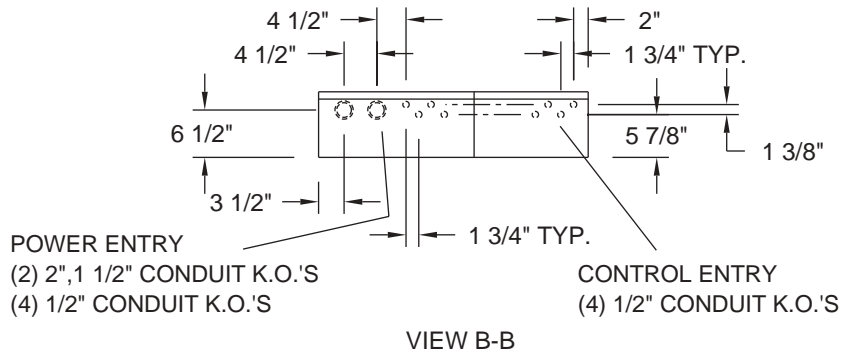

LD04868

NOTE:

Placement on a level surface of free of obstructions (including snow, for winter operation) or air circulation ensures rated performance, reliable operation, and ease of maintenance. Site restrictions may compromise minimum clearances indicated below, resulting in unpredictable airflow patterns and possible diminished performance. YORK's unit controls will optimize operation without nuisance high-pressure safety cutouts; however, the system designer must consider potential performance degradation. Access to the unit control center assumes the unit is no higher than on spring isolators. Recommended minimum clearances: Side to wall - 6'; rear to wall - 6'; control panel to end wall - 4'0"; top - no obstructions allowed; distance between adjacent units - 10'. No more than one adjacent wall may be higher than the unit.

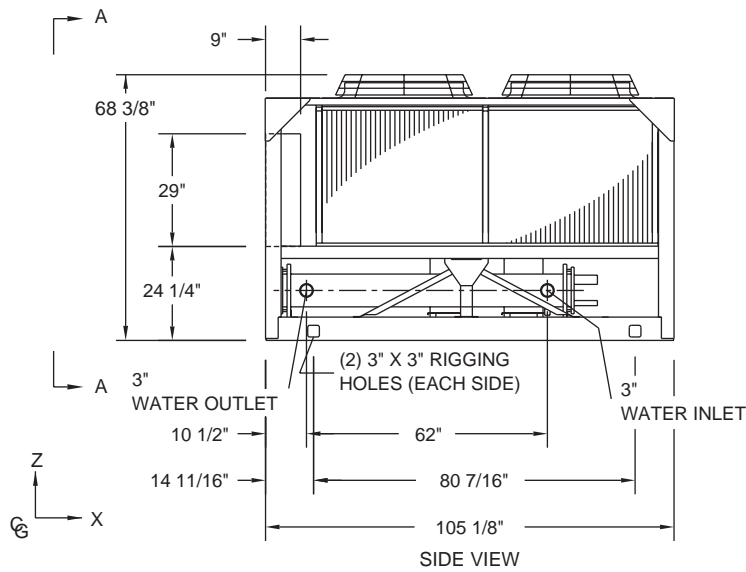
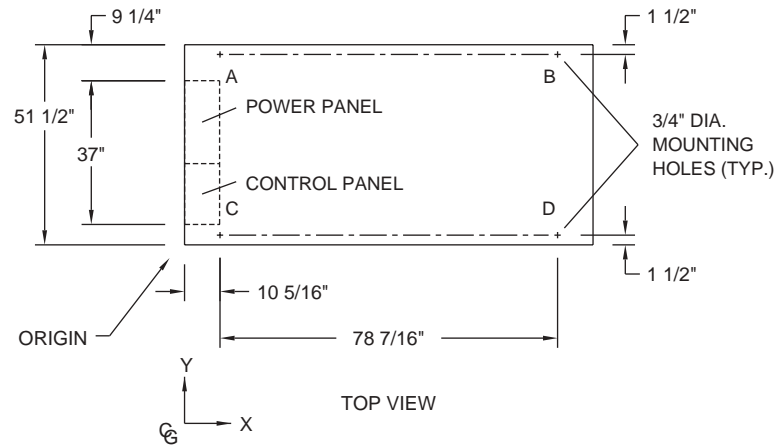

LD04869

ALUMINUM

MODEL	CENTER OF GRAVITY (IN.)		
	X	Y	Z
0014	50.6	25.8	23.3
0020	50.6	25.9	23.2

COPPER

MODEL	CENTER OF GRAVITY (IN.)		
	X	Y	Z
0014	50.6	25.8	24.9
0020	50.6	25.9	24.9

DIMENSIONS - YCAL0024-YCAL0034 (ENGLISH)

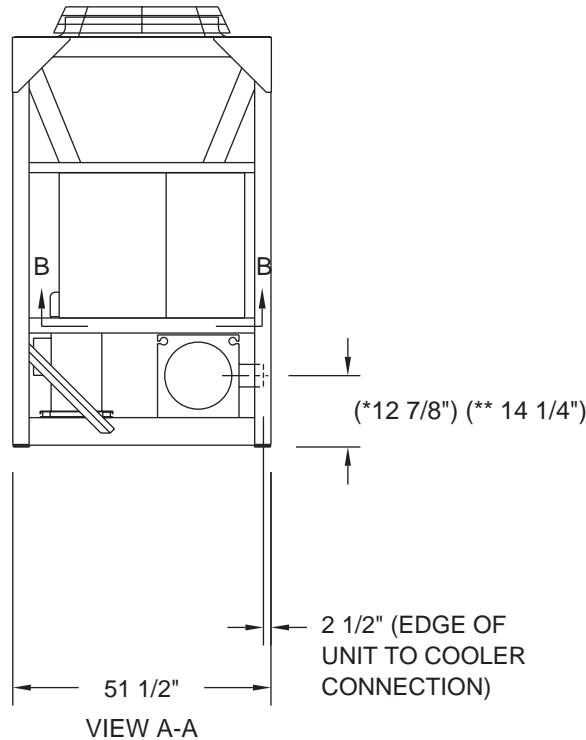
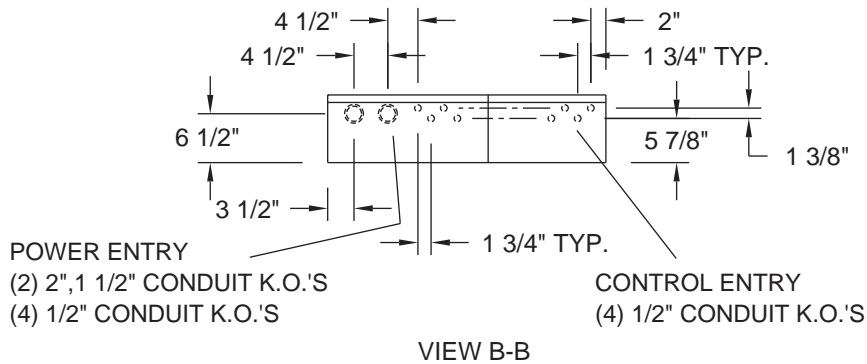

LD04857

- * Refers to Model YCAL0024
- ** Refers to Model YCAL0030 and YCAL0034

NOTE:

Placement on a level surface of free of obstructions (including snow, for winter operation) or air circulation ensures rated performance, reliable operation, and ease of maintenance. Site restrictions may compromise minimum clearances indicated below, resulting in unpredictable airflow patterns and possible diminished performance. YORK's unit controls will optimize operation without nuisance high-pressure safety cutouts; however, the system designer must consider potential performance degradation. Access to the unit control center assumes the unit is no higher than on spring isolators. Recommended minimum clearances: Side to wall – 6'; rear to wall – 6'; control panel to end wall – 4'0"; top – no obstructions allowed; distance between adjacent units – 10'. No more than one adjacent wall may be higher than the unit.

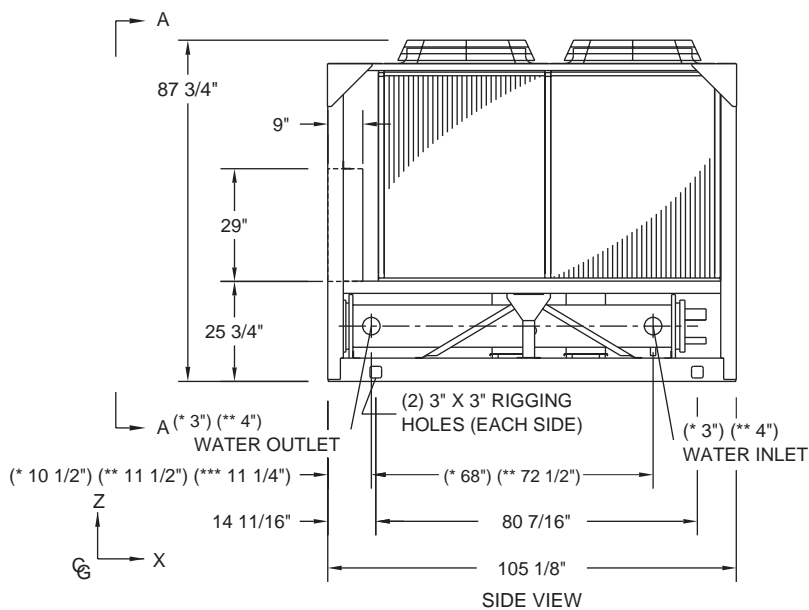
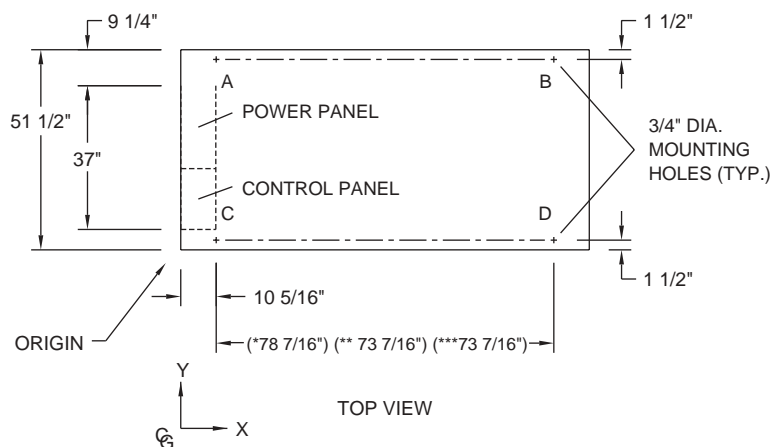

LD04858

* Refers to Model YCAL0024

** Refers to Model YCAL0030 and YCAL0034

ALUMINUM

MODEL	CENTER OF GRAVITY (IN.)		
	X	Y	Z
0024	51.4	26.1	28.5
0030	51.3	25.8	29.2
0034	49.0	25.4	28.0

COPPER

MODEL	CENTER OF GRAVITY (IN.)		
	X	Y	Z
0024	51.4	26.1	31.0
0030	51.3	25.8	32.0
0034	49.0	25.4	31.1

DIMENSIONS - YCAL0040-YCAL0060 (ENGLISH)

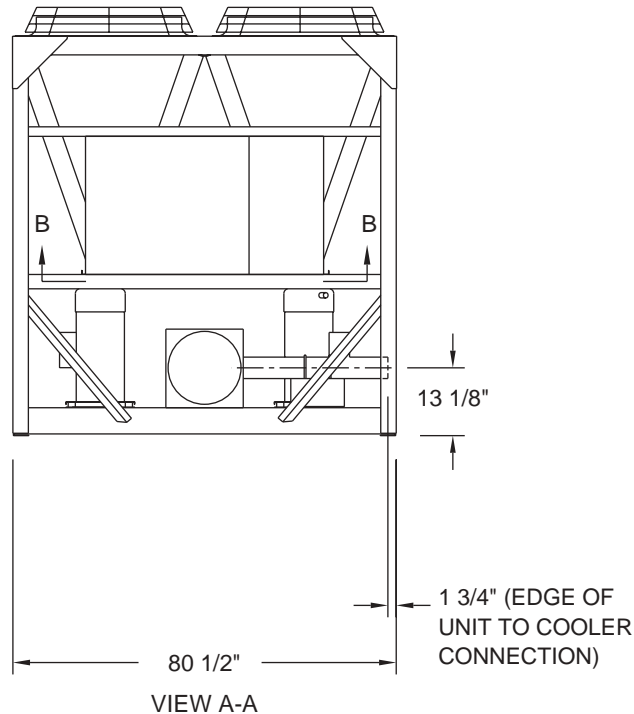
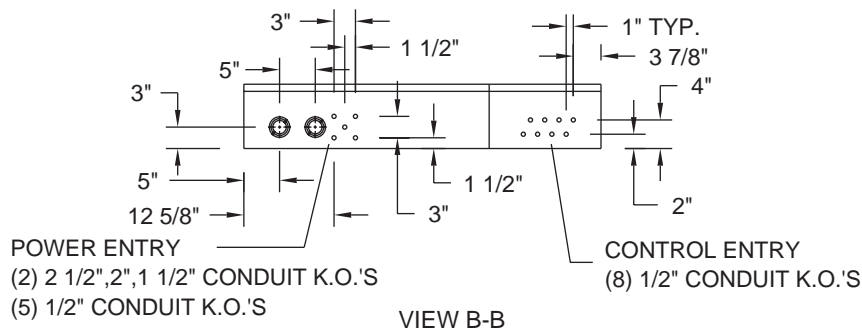

LD04872

NOTE:

Placement on a level surface of free of obstructions (including snow, for winter operation) or air circulation ensures rated performance, reliable operation, and ease of maintenance. Site restrictions may compromise minimum clearances indicated below, resulting in unpredictable airflow patterns and possible diminished performance. YORK's unit controls will optimize operation without nuisance high-pressure safety cutouts; however, the system designer must consider potential performance degradation. Access to the unit control center assumes the unit is no higher than on spring isolators. Recommended minimum clearances: Side to wall – 6'; rear to wall – 6'; control panel to end wall – 4'0"; top – no obstructions allowed; distance between adjacent units – 10'. No more than one adjacent wall may be higher than the unit.

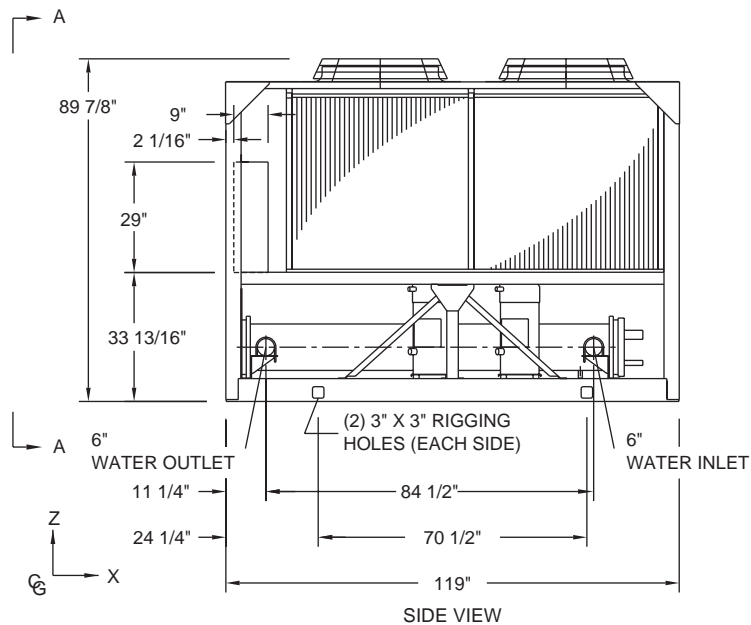
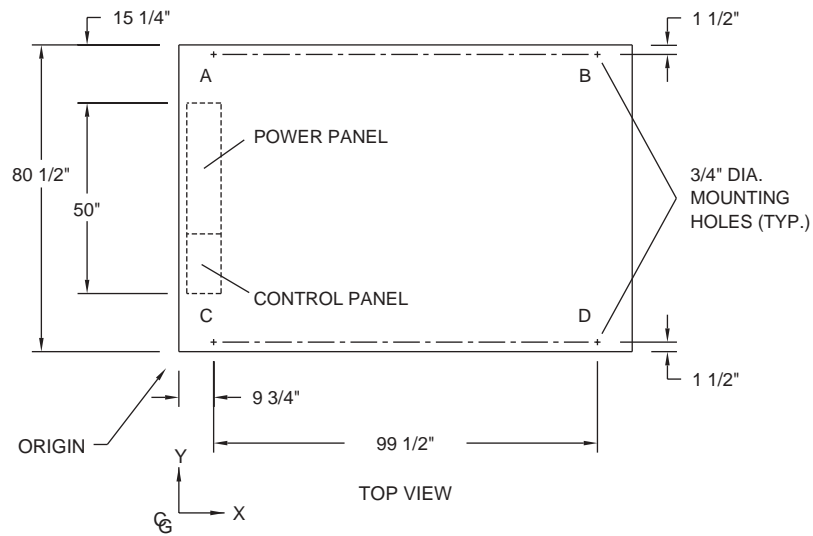

LD04873

ALUMINUM

MODEL	CENTER OF GRAVITY (IN.)		
	X	Y	Z
0040	59.1	40.3	29.3
0042	59.2	40.5	28.8
0044	59.2	40.3	29.0
0050	59.3	40.4	28.8
0060	59.9	40.3	30.3

COPPER

MODEL	CENTER OF GRAVITY (IN.)		
	X	Y	Z
0040	59.1	40.3	32.1
0042	59.2	40.5	31.4
0044	59.2	40.3	31.8
0050	59.3	40.4	31.5
0060	59.9	40.3	34.4

DIMENSIONS - YCAL0064-YCAL0080 (ENGLISH)

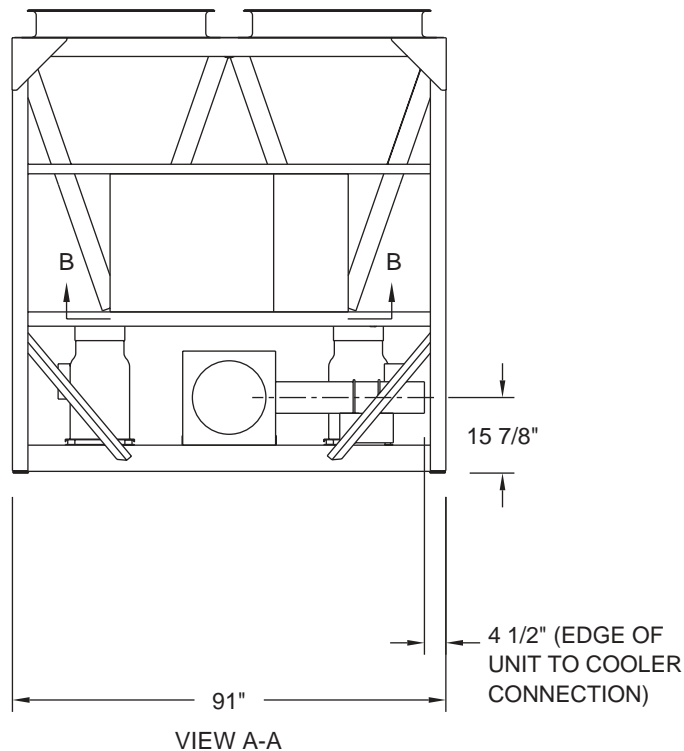
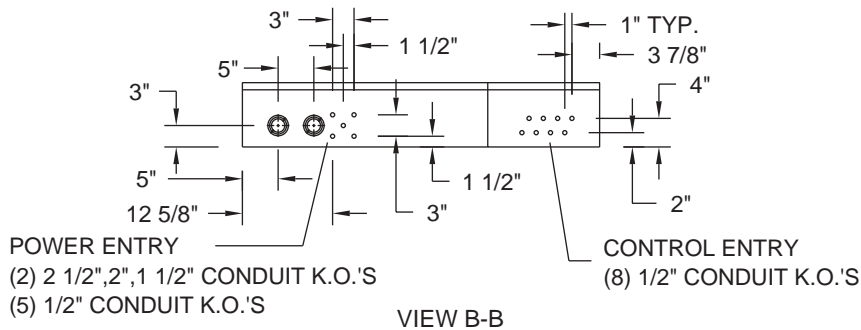

LD04876

NOTE:

Placement on a level surface of free of obstructions (including snow, for winter operation) or air circulation ensures rated performance, reliable operation, and ease of maintenance. Site restrictions may compromise minimum clearances indicated below, resulting in unpredictable airflow patterns and possible diminished performance. YORK's unit controls will optimize operation without nuisance high-pressure safety cutouts; however, the system designer must consider potential performance degradation. Access to the unit control center assumes the unit is no higher than on spring isolators. Recommended minimum clearances: Side to wall – 6'; rear to wall – 6'; control panel to end wall – 4'0"; top – no obstructions allowed; distance between adjacent units – 10'. No more than one adjacent wall may be higher than the unit.

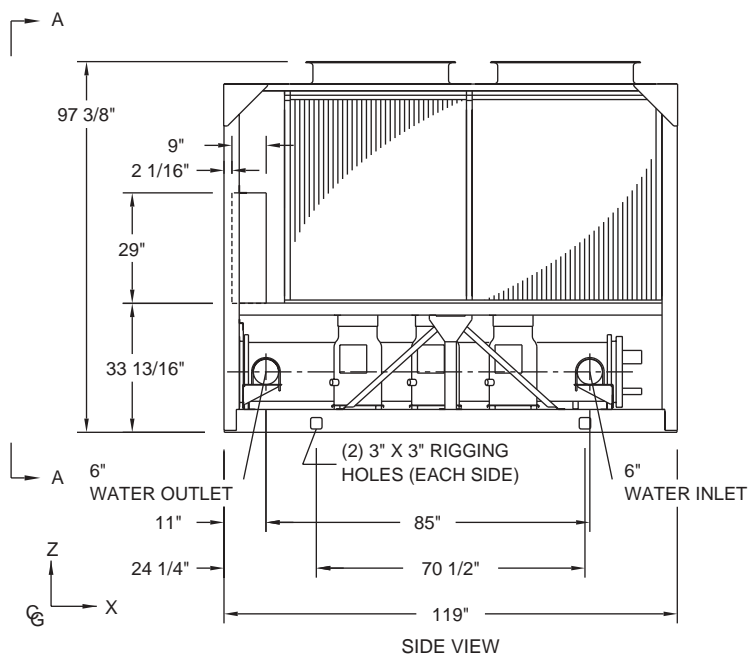
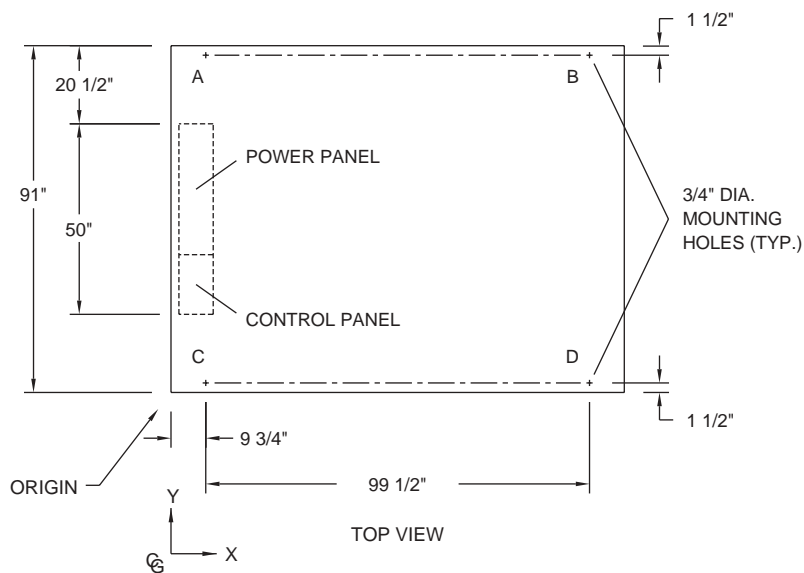

LD04877

ALUMINUM

MODEL	CENTER OF GRAVITY (IN.)		
	X	Y	Z
0064	57.1	45.9	31.4
0070	57.2	45.6	32.1
0074	57.5	45.9	32.2
0080	57.6	45.6	30.8

COPPER

MODEL	CENTER OF GRAVITY (IN.)		
	X	Y	Z
0064	57.1	45.9	34.6
0070	57.2	45.6	35.0
0074	57.5	45.9	36.0
0080	57.6	45.6	34.9

DIMENSIONS - YCAL0090-YCAL0094 (ENGLISH)

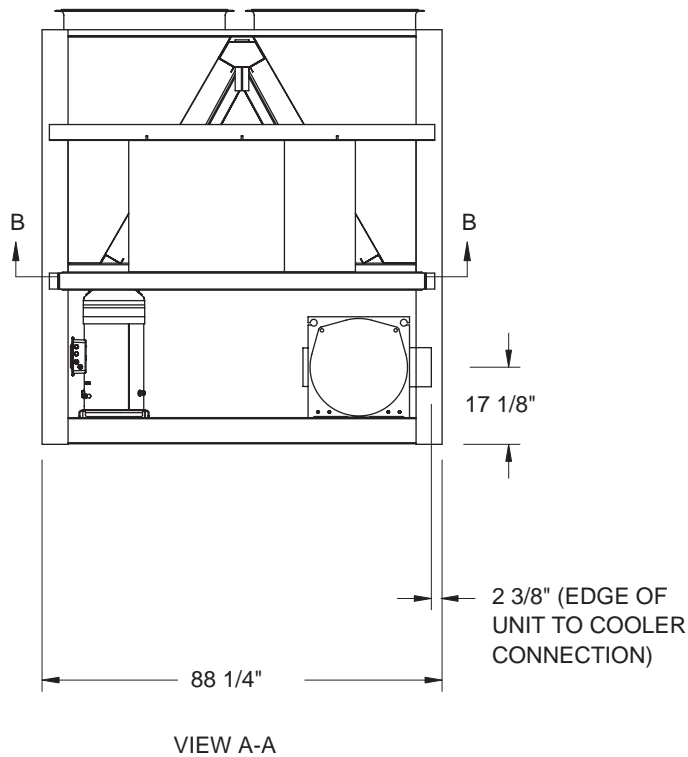
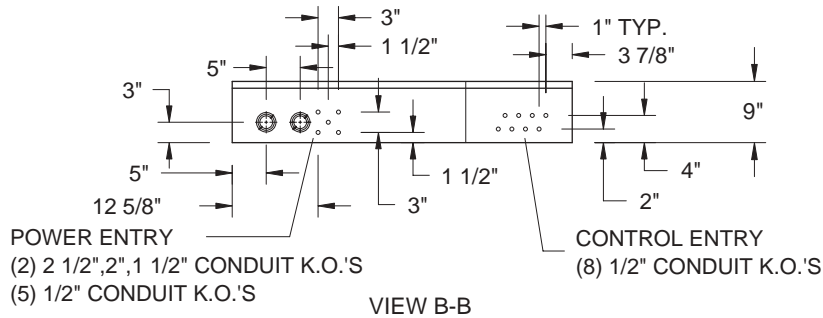

POWER: MULTIPLE POINT WITH TERMINAL BLOCKS

NOTE:

Placement on a level surface of free of obstructions (including snow, for winter operation) or air circulation ensures rated performance, reliable operation, and ease of maintenance. Site restrictions may compromise minimum clearances indicated below, resulting in unpredictable airflow patterns and possible diminished performance. YORK's unit controls will optimize operation without nuisance high-pressure safety cutouts; however, the system designer must consider potential performance degradation. Access to the unit control center assumes the unit is no higher than on spring isolators. Recommended minimum clearances: Side to wall - 6'; rear to wall - 6'; control panel to end wall - 4'0"; top - no obstructions allowed; distance between adjacent units - 10'. No more than one adjacent wall may be higher than the unit.

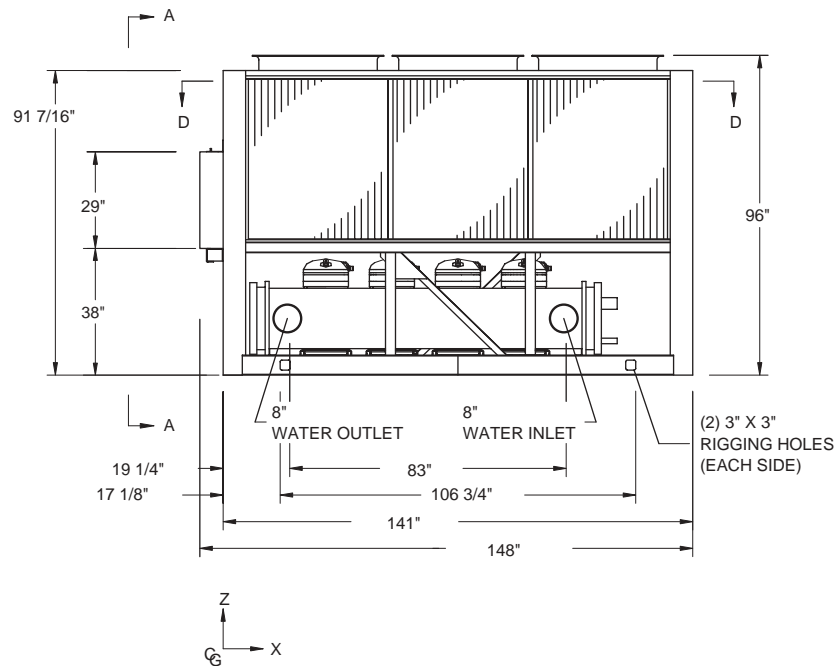
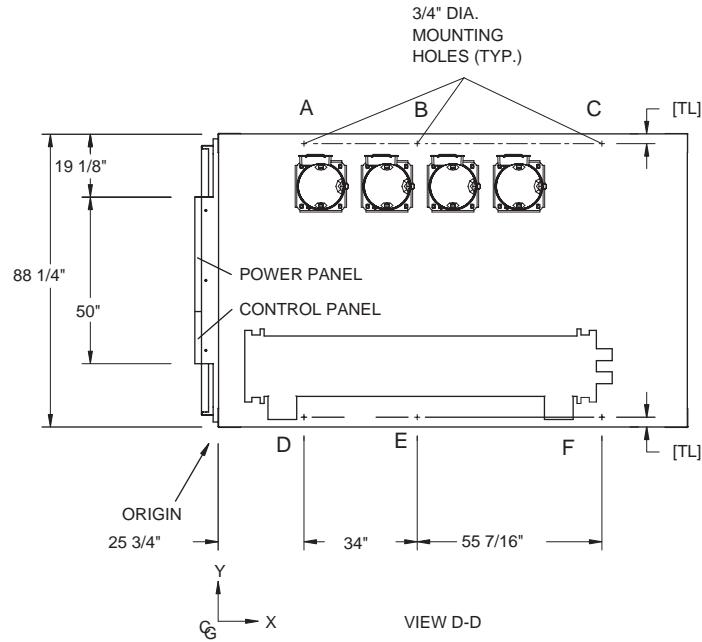

ALUMINUM

MODEL	CENTER OF GRAVITY (IN.)		
	X	Y	Z
0090	63.4	44.3	42.1
0094	64.2	44.4	41.9

COPPER

MODEL	CENTER OF GRAVITY (IN.)		
	X	Y	Z
0090	64.1	44.3	44.5
0094	64.8	44.4	44.2

DIMENSIONS - YCAL0104 (ENGLISH)

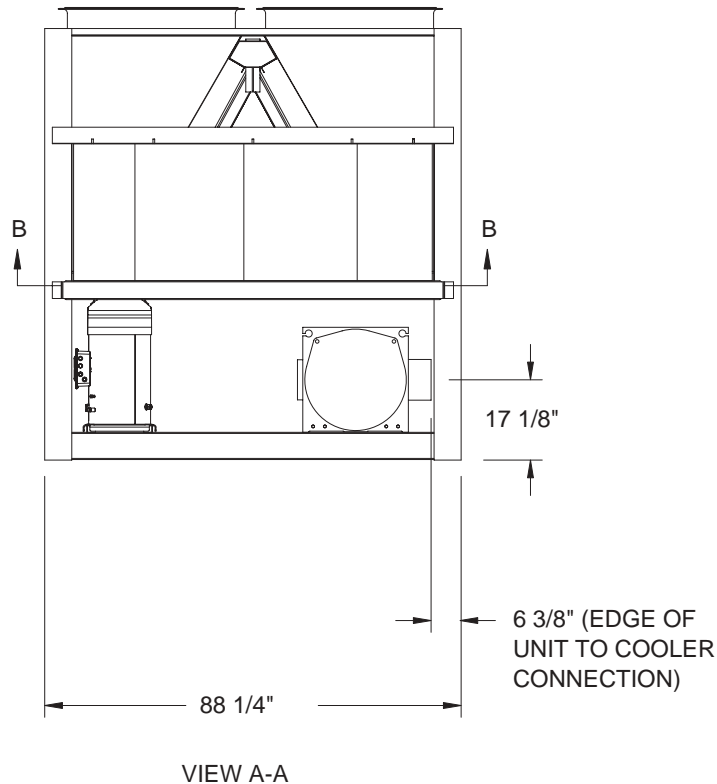
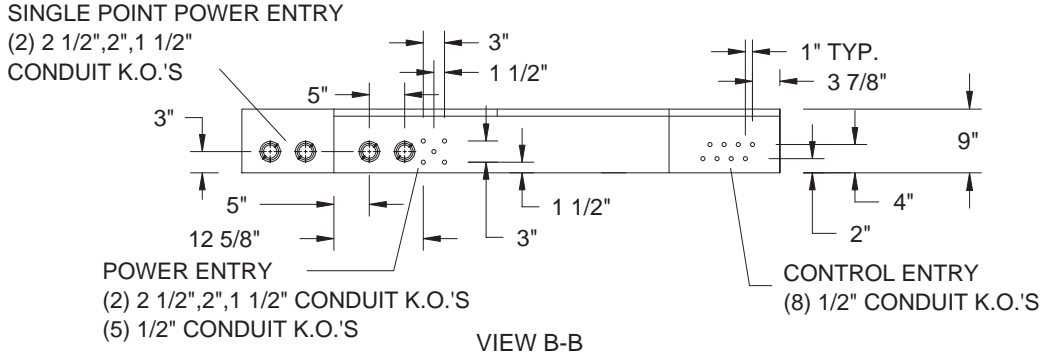

NOTE:

Placement on a level surface of free of obstructions (including snow, for winter operation) or air circulation ensures rated performance, reliable operation, and ease of maintenance. Site restrictions may compromise minimum clearances indicated below, resulting in unpredictable airflow patterns and possible diminished performance. YORK's unit controls will optimize operation without nuisance high-pressure safety cutouts; however, the system designer must consider potential performance degradation. Access to the unit control center assumes the unit is no higher than on spring isolators. Recommended minimum clearances: Side to wall – 6'; rear to wall – 6'; control panel to end wall – 4'0"; top – no obstructions allowed; distance between adjacent units – 10'. No more than one adjacent wall may be higher than the unit.

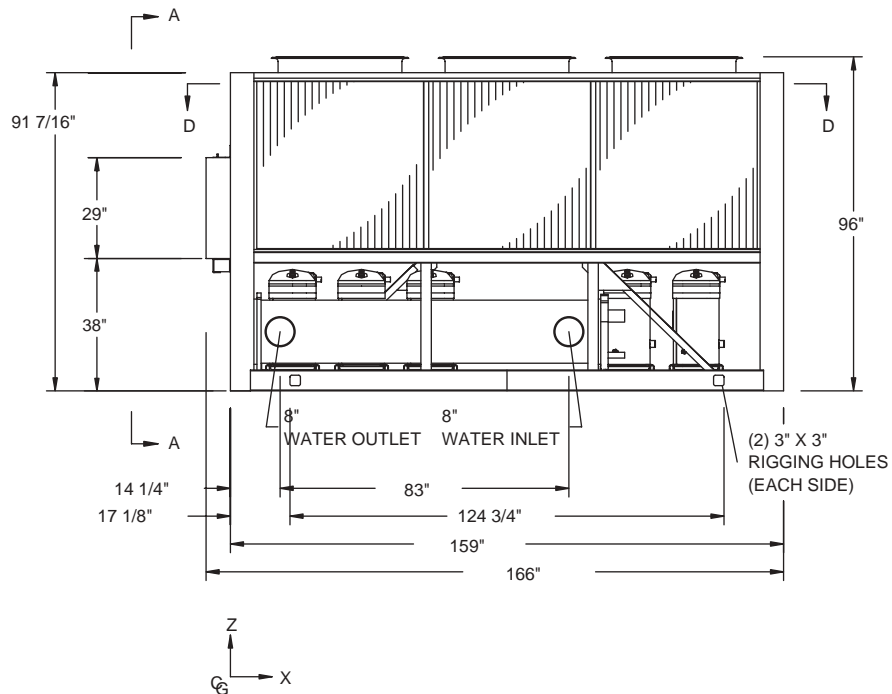
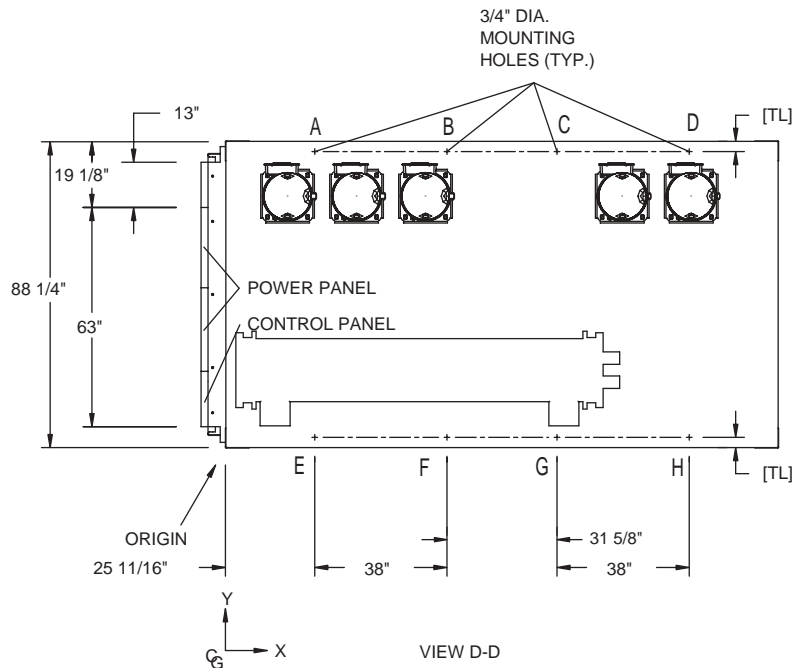

ALUMINUM

MODEL	CENTER OF GRAVITY (IN.)		
	X	Y	Z
0104	70.3	45.7	40.8

COPPER

MODEL	CENTER OF GRAVITY (IN.)		
	X	Y	Z
0104	71.3	45.5	42.7

DIMENSIONS - YCAL0114 - YCAL0124 (ENGLISH)

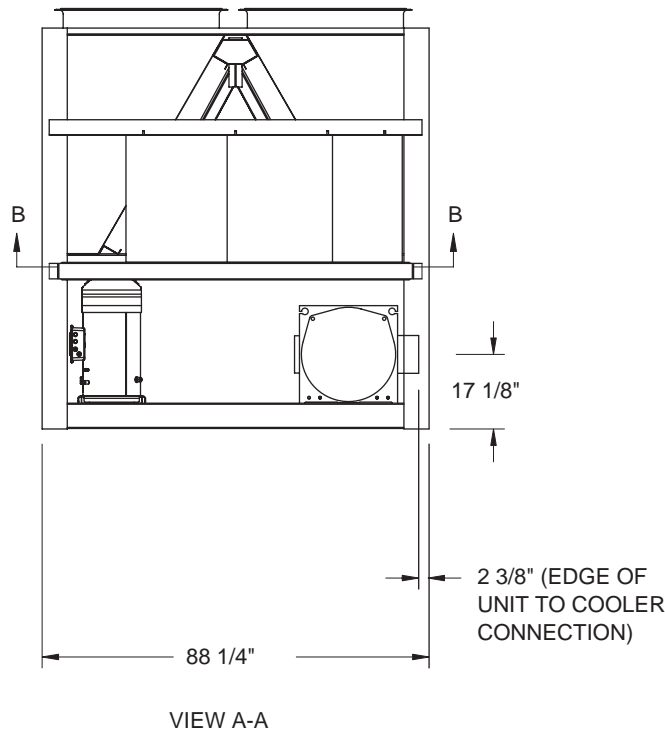
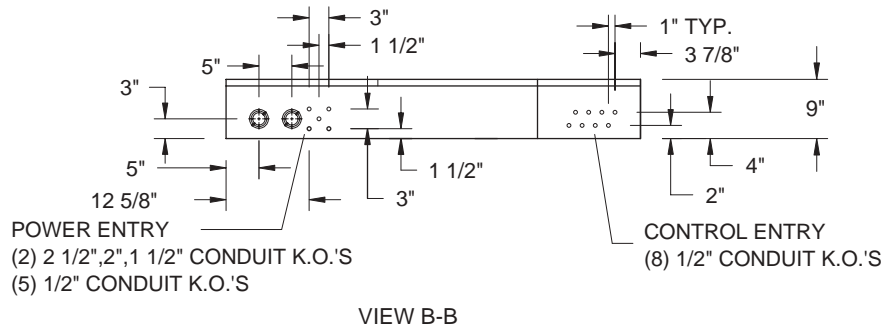

POWER: MULTIPLE POINT WITH TERMINAL BLOCKS

NOTE:

Placement on a level surface of free of obstructions (including snow, for winter operation) or air circulation ensures rated performance, reliable operation, and ease of maintenance. Site restrictions may compromise minimum clearances indicated below, resulting in unpredictable airflow patterns and possible diminished performance. YORK's unit controls will optimize operation without nuisance high-pressure safety cutouts; however, the system designer must consider potential performance degradation. Access to the unit control center assumes the unit is no higher than on spring isolators. Recommended minimum clearances: Side to wall – 6'; rear to wall – 6'; control panel to end wall – 4'0"; top – no obstructions allowed; distance between adjacent units – 10'. No more than one adjacent wall may be higher than the unit.

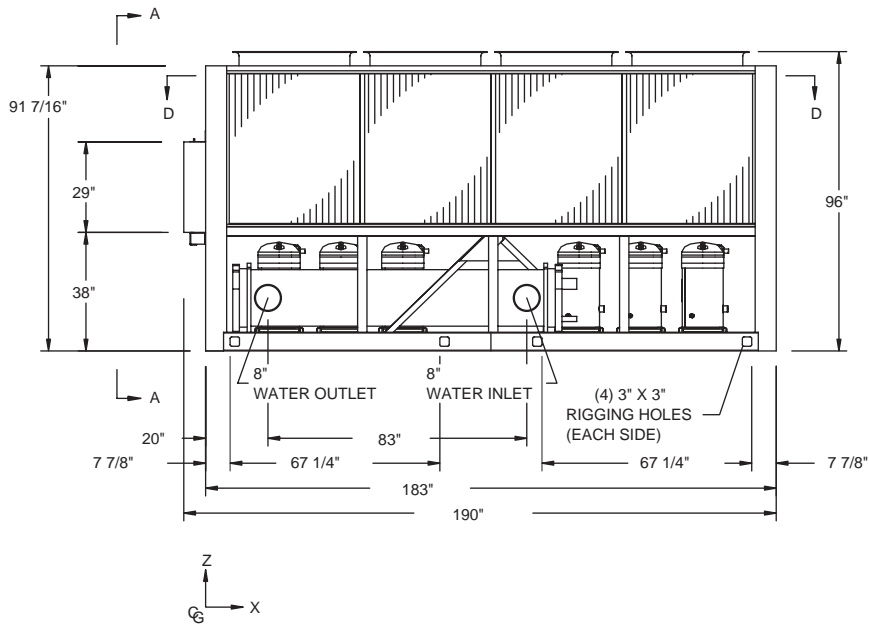
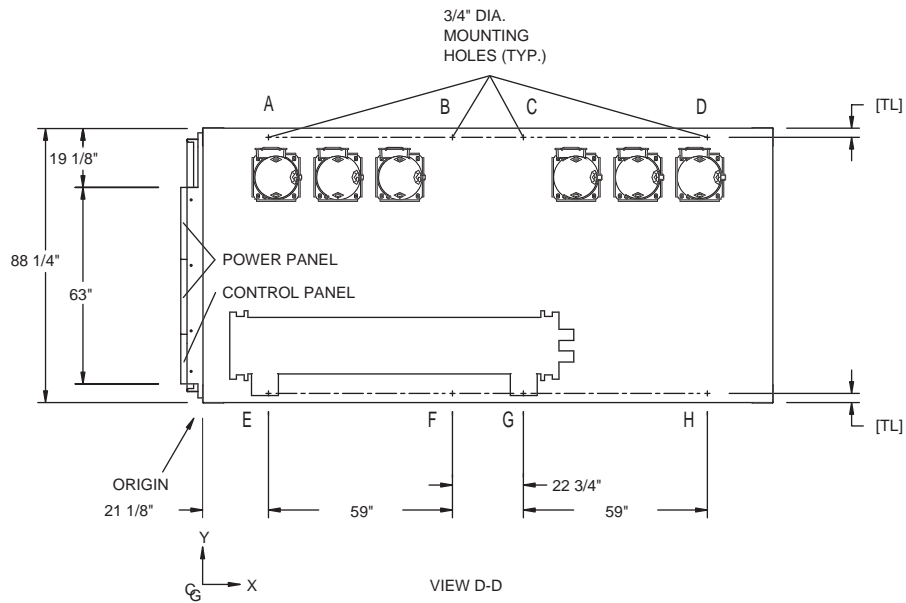

ALUMINUM

MODEL	CENTER OF GRAVITY (IN.)		
	X	Y	Z
0114	79.4	45.0	41.4
0124	79.4	45.0	41.5

COPPER

MODEL	CENTER OF GRAVITY (IN.)		
	X	Y	Z
0114	80.9	44.9	43.5
0124	80.9	44.9	43.5

DIMENSIONS - YCAL0014-YCAL0020 (SI)

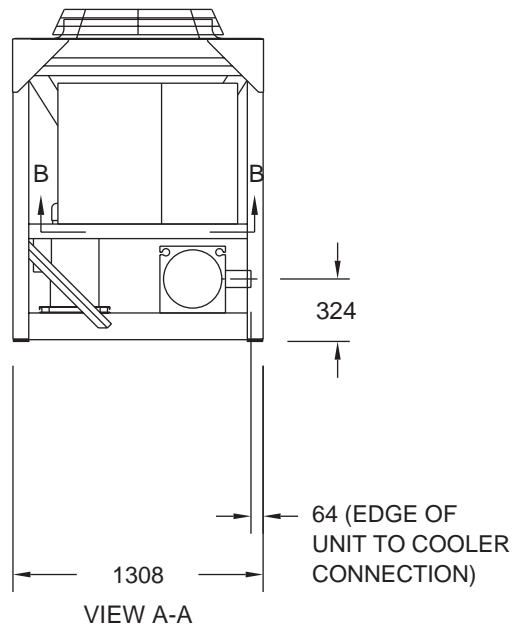
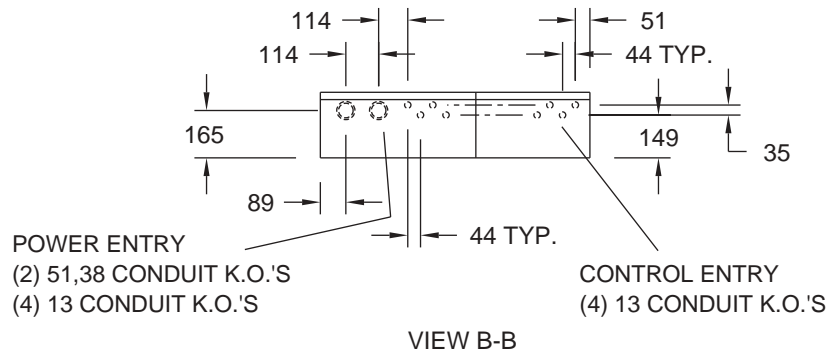

LD04870

NOTE: All dimensions are in mm unless specified otherwise.

NOTE:

Placement on a level surface of free of obstructions (including snow, for winter operation) or air circulation ensures rated performance, reliable operation, and ease of maintenance. Site restrictions may compromise minimum clearances indicated below, resulting in unpredictable airflow patterns and possible diminished performance. YORK's unit controls will optimize operation without nuisance high-pressure safety cutouts; however, the system designer must consider potential performance degradation. Access to the unit control center assumes the unit is no higher than on spring isolators. Recommended minimum clearances: Side to wall – 2m; rear to wall – 2m; control panel to end wall – 1.2m; top – no obstructions allowed; distance between adjacent units – 3m. No more than one adjacent wall may be higher than the unit.

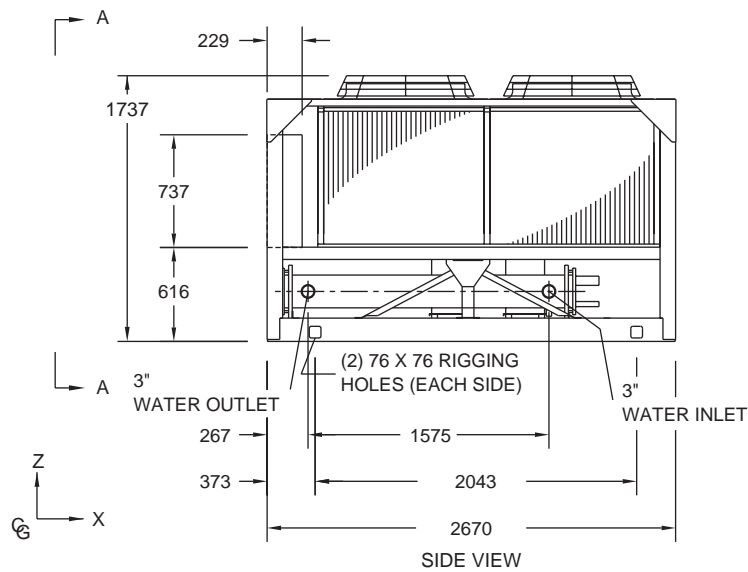
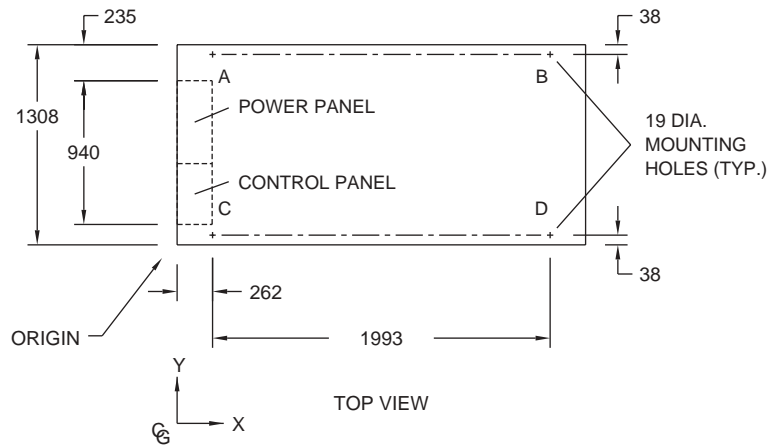

LD04871

ALUMINUM

MODEL	CENTER OF GRAVITY (mm)		
	X	Y	Z
0014	1286	656	592
0020	1286	657	589

COPPER

MODEL	CENTER OF GRAVITY (mm)		
	X	Y	Z
0014	1286	656	632
0020	1286	657	632

DIMENSIONS - YCAL0024-YCAL0034 (SI)

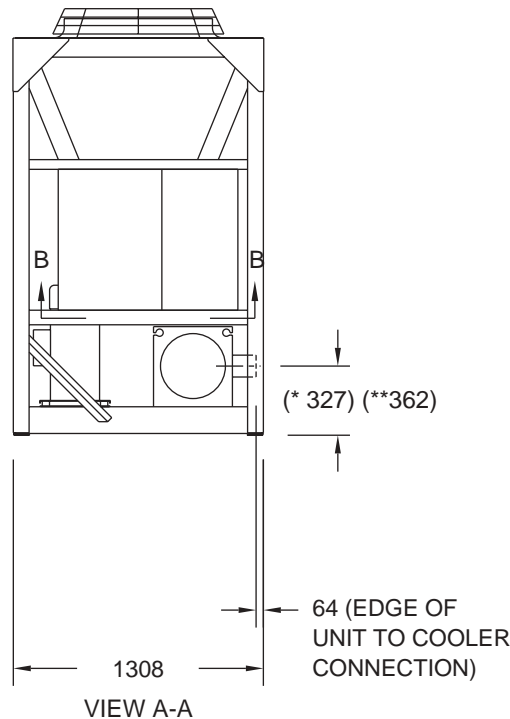
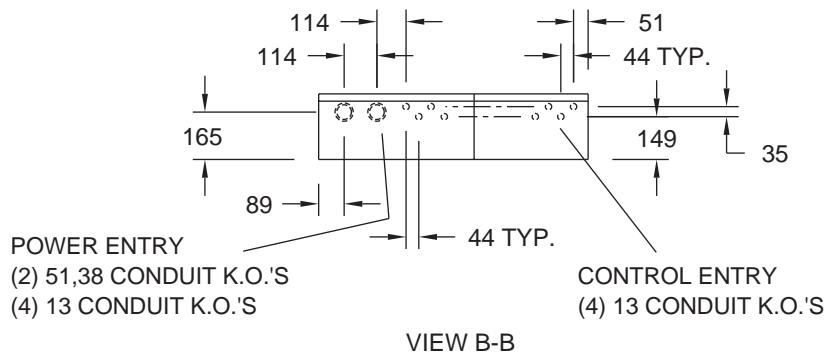

* Refers to Model YCAL0024
 ** Refers to Model YCAL0030 and YCAL0034

LD04859

NOTE: All dimensions are in mm unless specified otherwise.

NOTE:

Placement on a level surface of free of obstructions (including snow, for winter operation) or air circulation ensures rated performance, reliable operation, and ease of maintenance. Site restrictions may compromise minimum clearances indicated below, resulting in unpredictable airflow patterns and possible diminished performance. YORK's unit controls will optimize operation without nuisance high-pressure safety cutouts; however, the system designer must consider potential performance degradation. Access to the unit control center assumes the unit is no higher than on spring isolators. Recommended minimum clearances: Side to wall – 2m; rear to wall – 2m; control panel to end wall – 1.2m; top – no obstructions allowed; distance between adjacent units – 3m. No more than one adjacent wall may be higher than the unit.

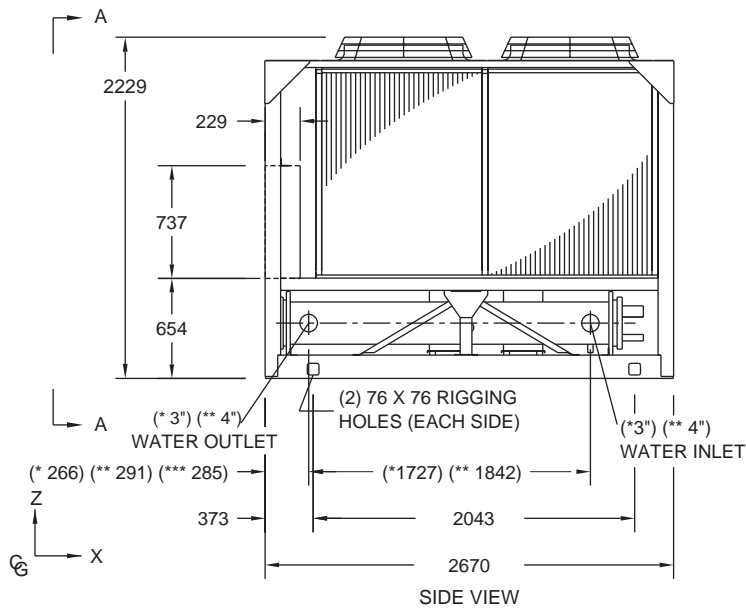
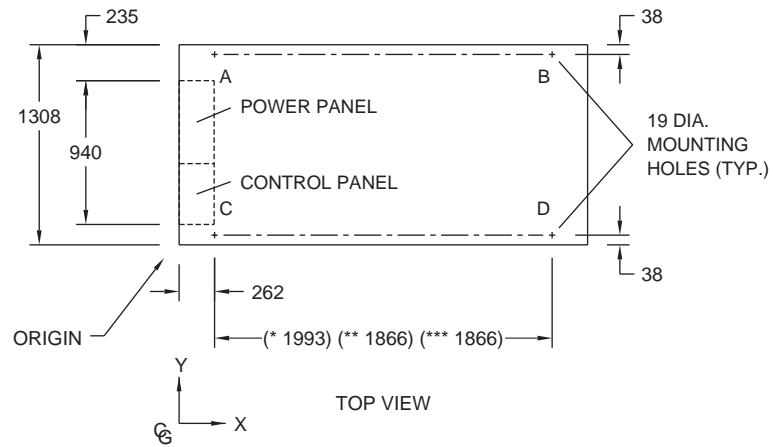

LD04860

* Refers to Model YCAL0024
 ** Refers to Model YCAL0030 and YCAL0034

ALUMINUM

MODEL	CENTER OF GRAVITY (mm)			
	YCAL	X	Y	Z
0024		1305	663	724
0030		1302	655	743
0034		1243	646	711

COPPER

MODEL	CENTER OF GRAVITY (mm)			
	YCAL	X	Y	Z
0024		1305	663	787
0030		1302	655	813
0034		1243	646	789

DIMENSIONS - YCAL0040-YCAL0060 (SI)

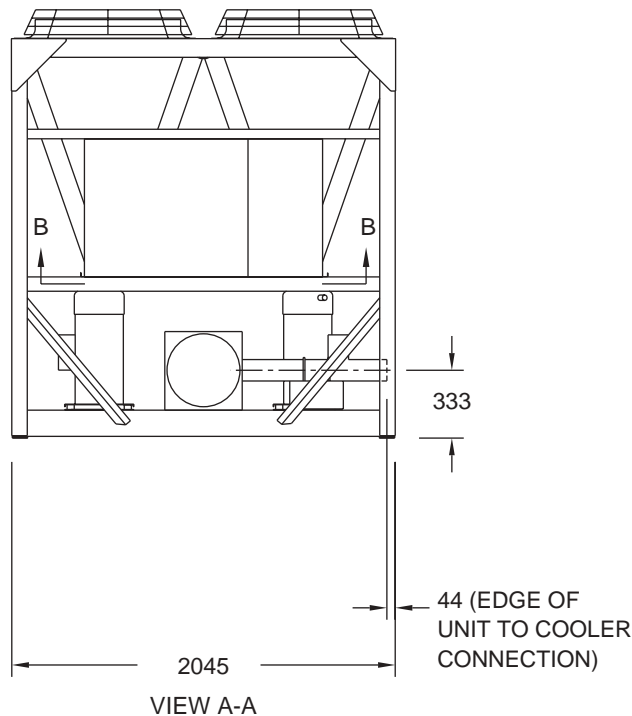
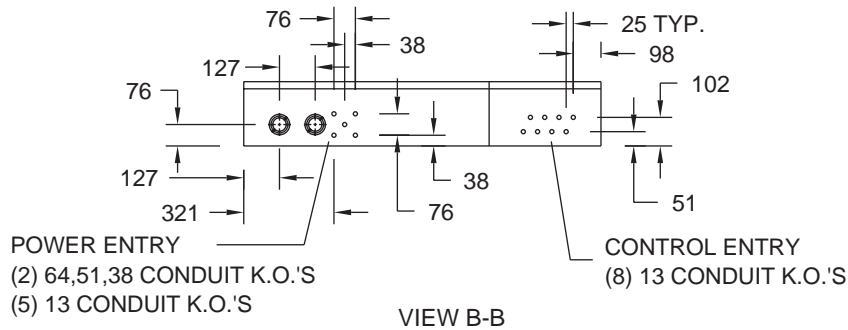

NOTE: All dimensions are in mm unless specified otherwise.

LD04874

NOTE:

Placement on a level surface of free of obstructions (including snow, for winter operation) or air circulation ensures rated performance, reliable operation, and ease of maintenance. Site restrictions may compromise minimum clearances indicated below, resulting in unpredictable airflow patterns and possible diminished performance. YORK's unit controls will optimize operation without nuisance high-pressure safety cutouts; however, the system designer must consider potential performance degradation. Access to the unit control center assumes the unit is no higher than on spring isolators. Recommended minimum clearances: Side to wall – 2m; rear to wall – 2m; control panel to end wall – 1.2m; top – no obstructions allowed; distance between adjacent units – 3m. No more than one adjacent wall may be higher than the unit.

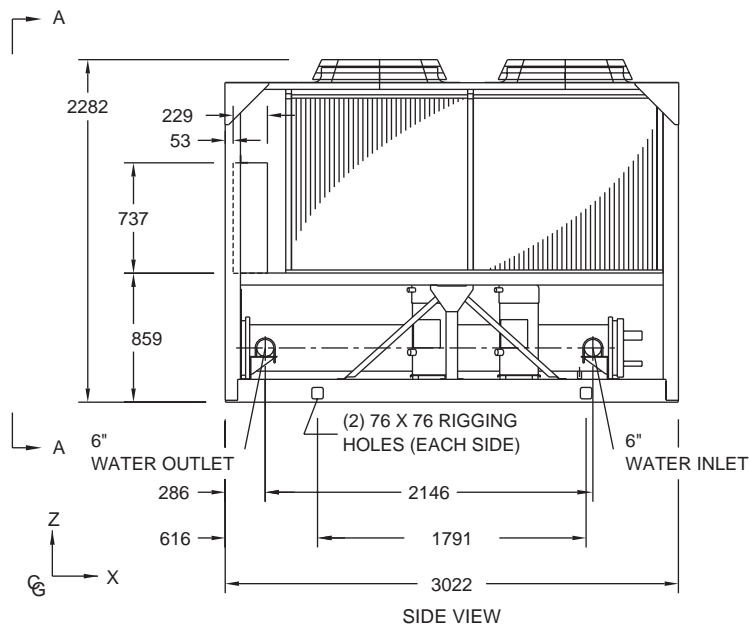
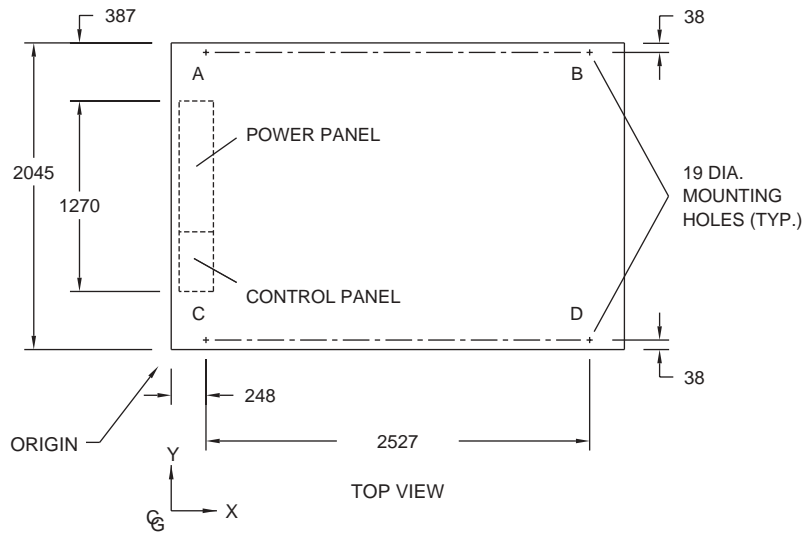

LD04875

ALUMINUM

MODEL	CENTER OF GRAVITY (mm)			
	YCAL	X	Y	Z
0040	1502	1022	745	
0042	1503	1027	732	
0044	1505	1022	737	
0050	1506	1027	732	
0060	1522	1022	771	

COPPER

MODEL	CENTER OF GRAVITY (mm)			
	YCAL	X	Y	Z
0040	1502	1022	815	
0042	1503	1027	798	
0044	1505	1022	807	
0050	1506	1027	801	
0060	1522	1022	874	

DIMENSIONS -YCAL0064-YCAL0080 (SI)

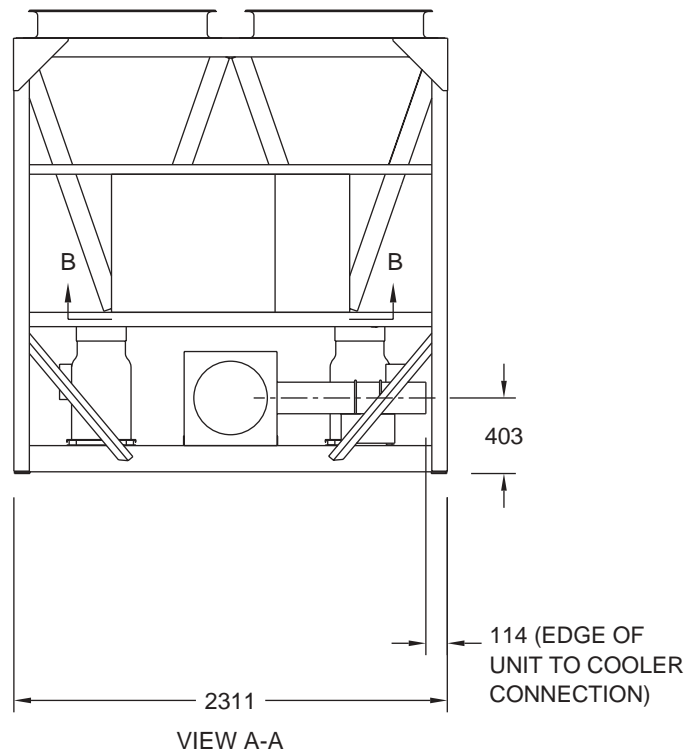
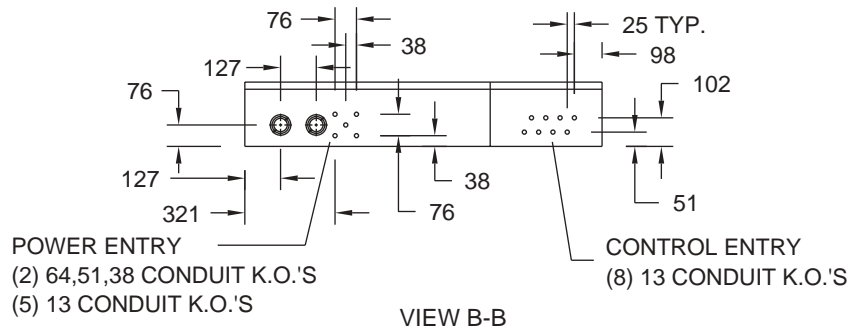

LD04878

NOTE: All dimensions are in mm unless specified otherwise.

NOTE:

Placement on a level surface of free of obstructions (including snow, for winter operation) or air circulation ensures rated performance, reliable operation, and ease of maintenance. Site restrictions may compromise minimum clearances indicated below, resulting in unpredictable airflow patterns and possible diminished performance. YORK's unit controls will optimize operation without nuisance high-pressure safety cutouts; however, the system designer must consider potential performance degradation. Access to the unit control center assumes the unit is no higher than on spring isolators. Recommended minimum clearances: Side to wall – 2m; rear to wall – 2m; control panel to end wall – 1.2m; top – no obstructions allowed; distance between adjacent units – 3m. No more than one adjacent wall may be higher than the unit.

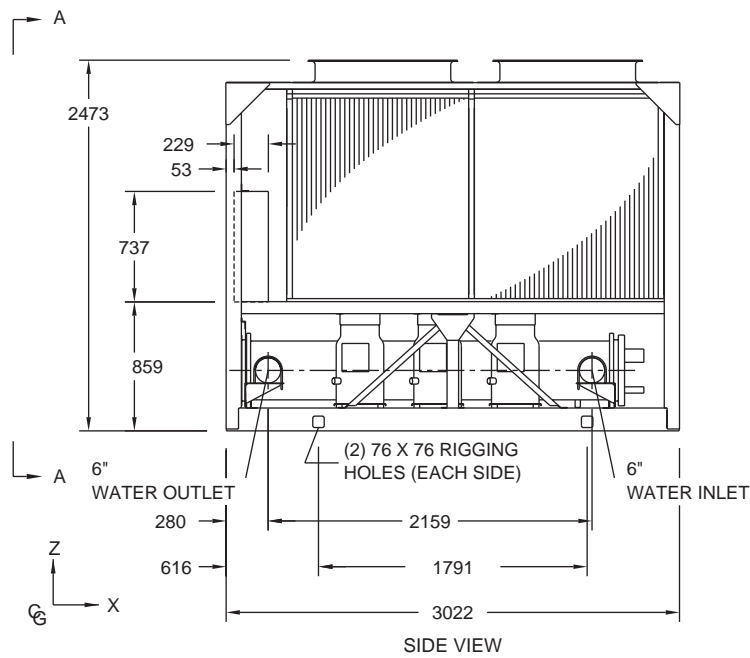
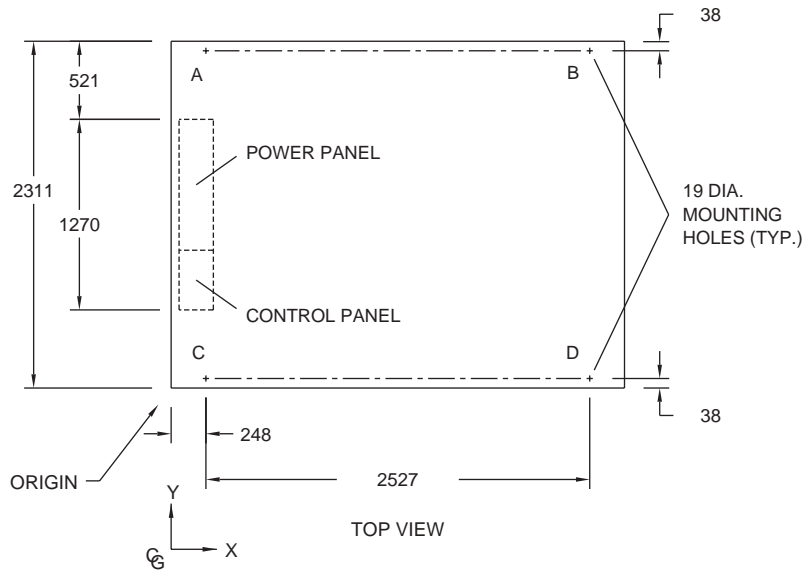

LD04879

ALUMINUM

MODEL	CENTER OF GRAVITY (mm)		
	X	Y	Z
0064	1450	1166	796
0070	1453	1159	816
0074	1459	1166	819
0080	1463	1158	782

COPPER

MODEL	CENTER OF GRAVITY (mm)		
	X	Y	Z
0064	1450	1166	880
0070	1453	1159	889
0074	1459	1166	915
0080	1463	1158	886

DIMENSIONS - YCAL0090-YCAL0094 (SI)

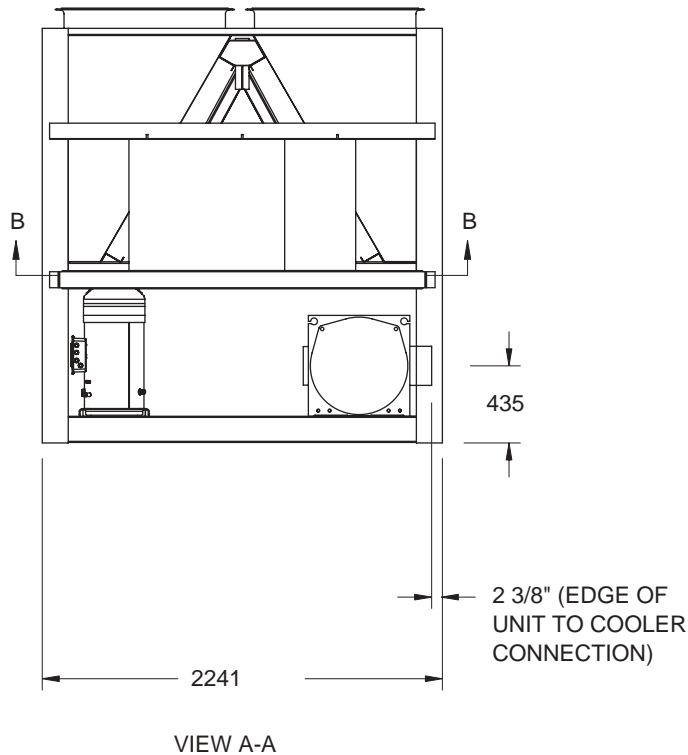
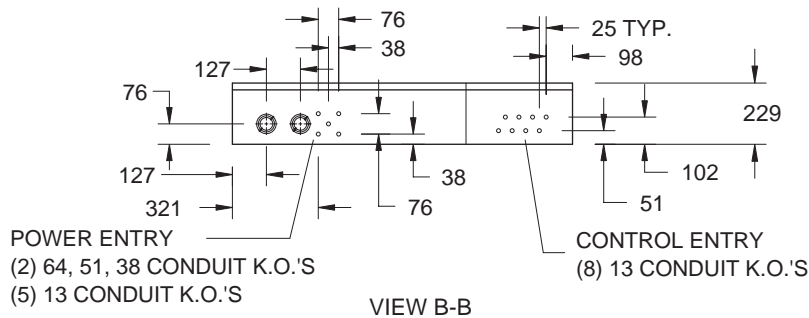

POWER: MULTIPLE POINT WITH TERMINAL BLOCKS

NOTE: All dimensions are in mm unless specified otherwise.

NOTE:

Placement on a level surface of free of obstructions (including snow, for winter operation) or air circulation ensures rated performance, reliable operation, and ease of maintenance. Site restrictions may compromise minimum clearances indicated below, resulting in unpredictable airflow patterns and possible diminished performance. YORK's unit controls will optimize operation without nuisance high-pressure safety cutouts; however, the system designer must consider potential performance degradation. Access to the unit control center assumes the unit is no higher than on spring isolators. Recommended minimum clearances: Side to wall – 2m; rear to wall – 2m; control panel to end wall – 1.2m; top – no obstructions allowed; distance between adjacent units – 3m. No more than one adjacent wall may be higher than the unit.

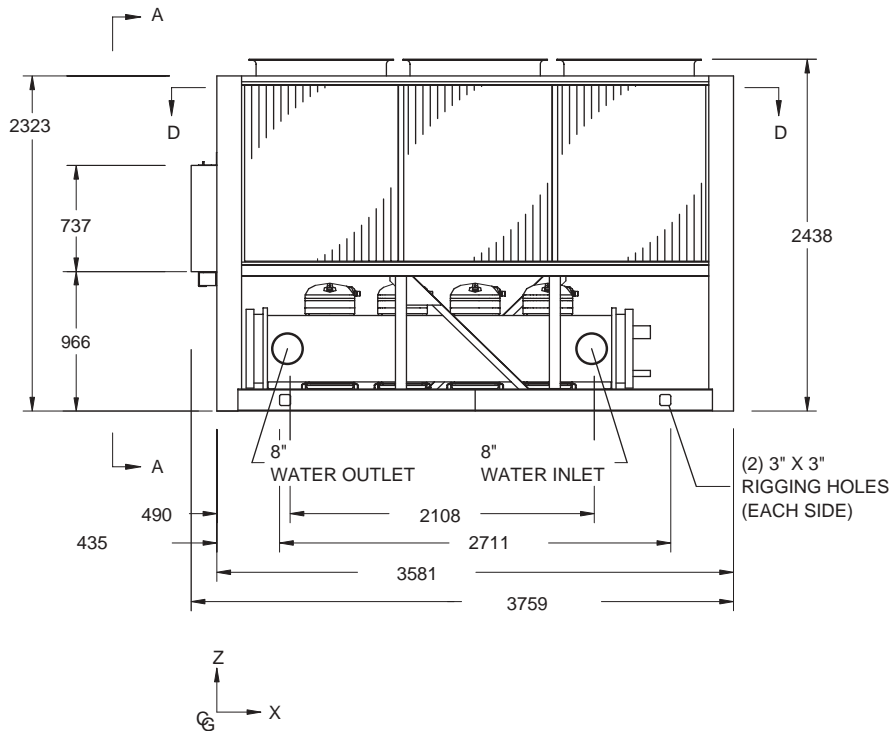
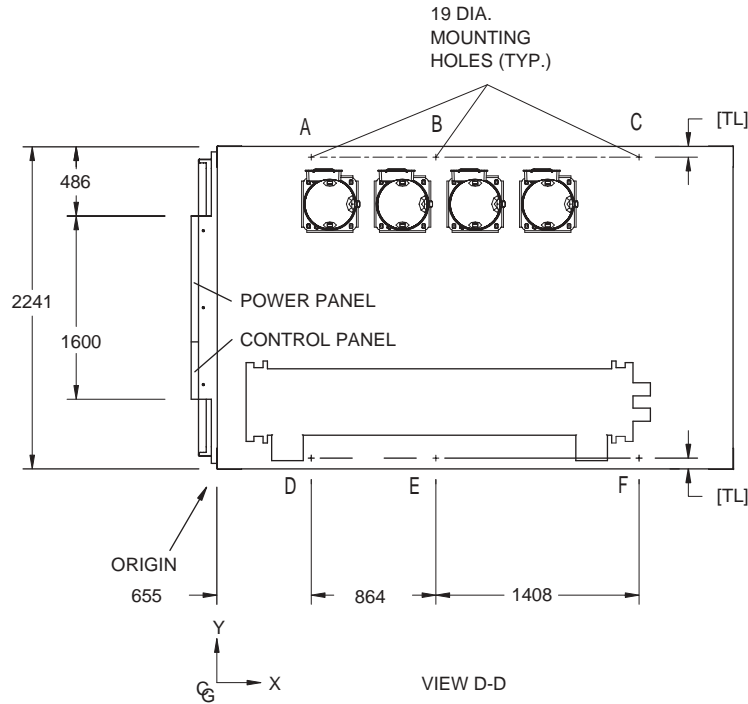

ALUMINUM

MODEL	CENTER OF GRAVITY (mm)		
	X	Y	Z
0090	1610	1125	1069
0094	1631	1128	1064

COPPER

MODEL	CENTER OF GRAVITY (mm)		
	X	Y	Z
0090	1628	1125	1130
0094	1646	1127	1124

DIMENSIONS - YCAL0104 (SI)

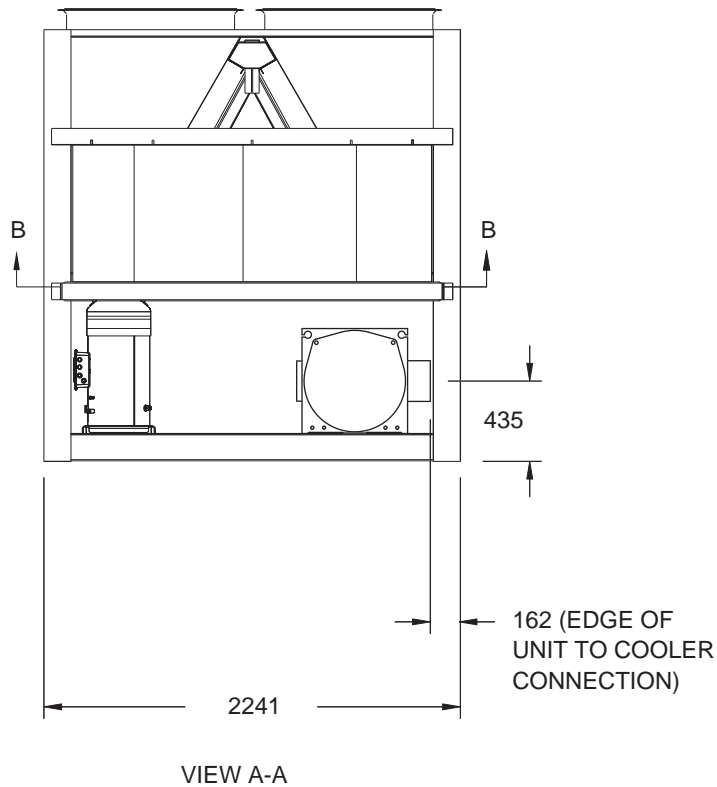
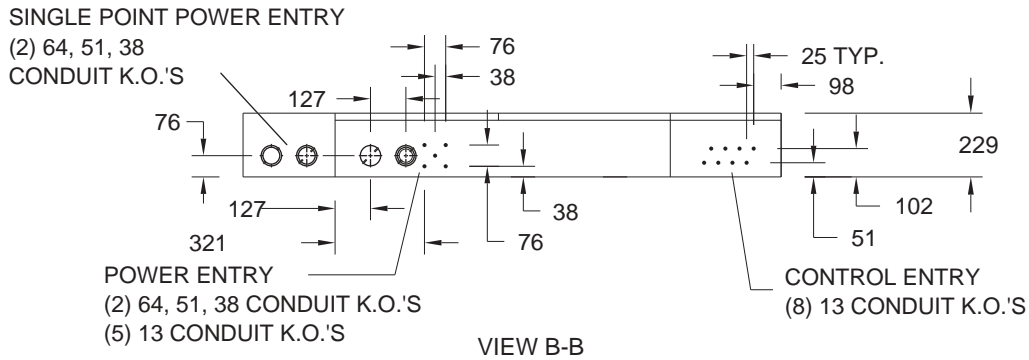

NOTE: All dimensions are in mm unless specified otherwise.

NOTE:

Placement on a level surface of free of obstructions (including snow, for winter operation) or air circulation ensures rated performance, reliable operation, and ease of maintenance. Site restrictions may compromise minimum clearances indicated below, resulting in unpredictable airflow patterns and possible diminished performance. YORK's unit controls will optimize operation without nuisance high-pressure safety cutouts; however, the system designer must consider potential performance degradation. Access to the unit control center assumes the unit is no higher than on spring isolators. Recommended minimum clearances: Side to wall – 2m; rear to wall – 2m; control panel to end wall – 1.2m; top – no obstructions allowed; distance between adjacent units – 3m. No more than one adjacent wall may be higher than the unit.

1

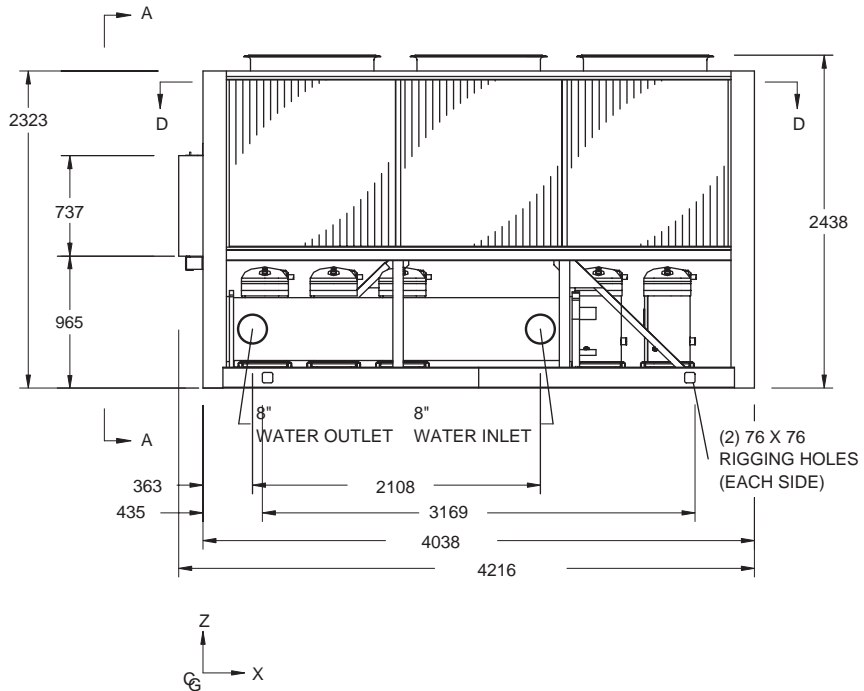
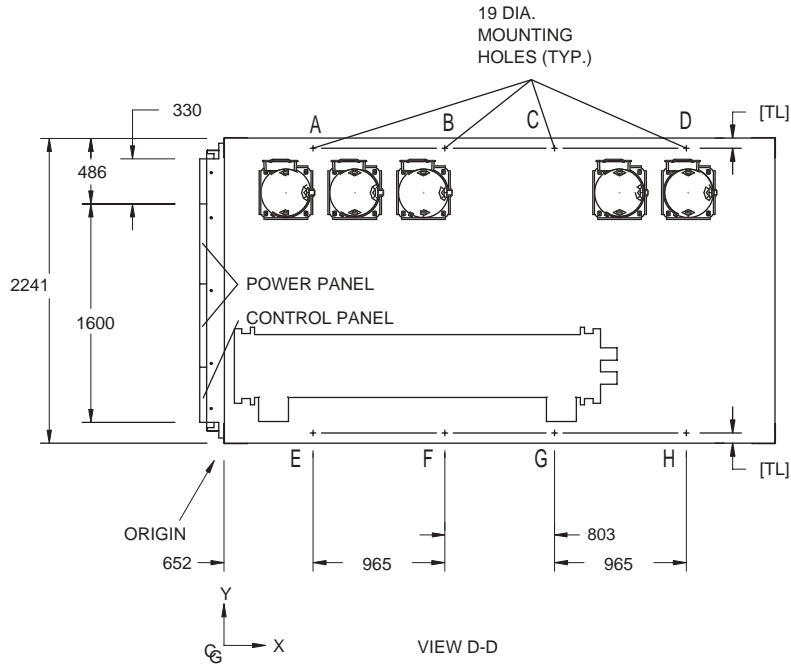

ALUMINUM

MODEL	CENTER OF GRAVITY (mm)		
	X	Y	Z
0104	1786	1160	1035

COPPER

MODEL	CENTER OF GRAVITY (mm)		
	X	Y	Z
0104	1811	1155	1084

DIMENSIONS - YCAL0114 - YCAL0124 (SI)

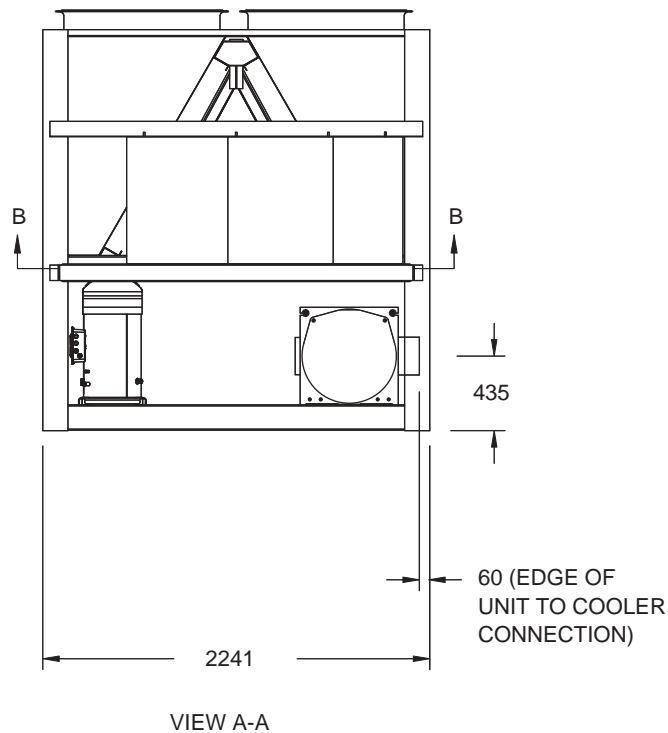
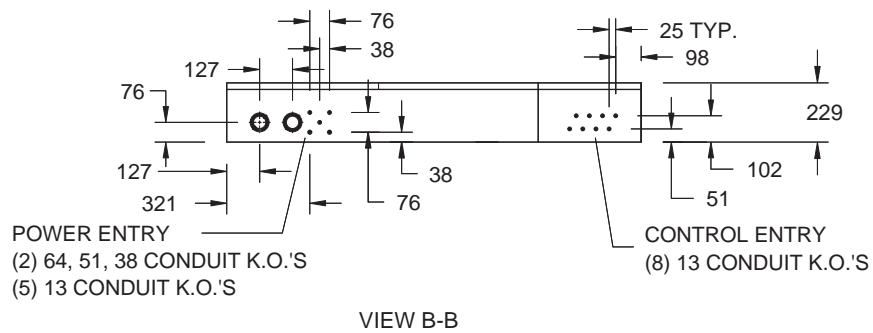

POWER: MULTIPLE POINT WITH TERMINAL BLOCKS

NOTE: All dimensions are in mm unless specified otherwise.

NOTE:

Placement on a level surface of free of obstructions (including snow, for winter operation) or air circulation ensures rated performance, reliable operation, and ease of maintenance. Site restrictions may compromise minimum clearances indicated below, resulting in unpredictable airflow patterns and possible diminished performance. YORK's unit controls will optimize operation without nuisance high-pressure safety cutouts; however, the system designer must consider potential performance degradation. Access to the unit control center assumes the unit is no higher than on spring isolators. Recommended minimum clearances: Side to wall – 2m; rear to wall – 2m; control panel to end wall – 1.2m; top – no obstructions allowed; distance between adjacent units – 3m. No more than one adjacent wall may be higher than the unit.

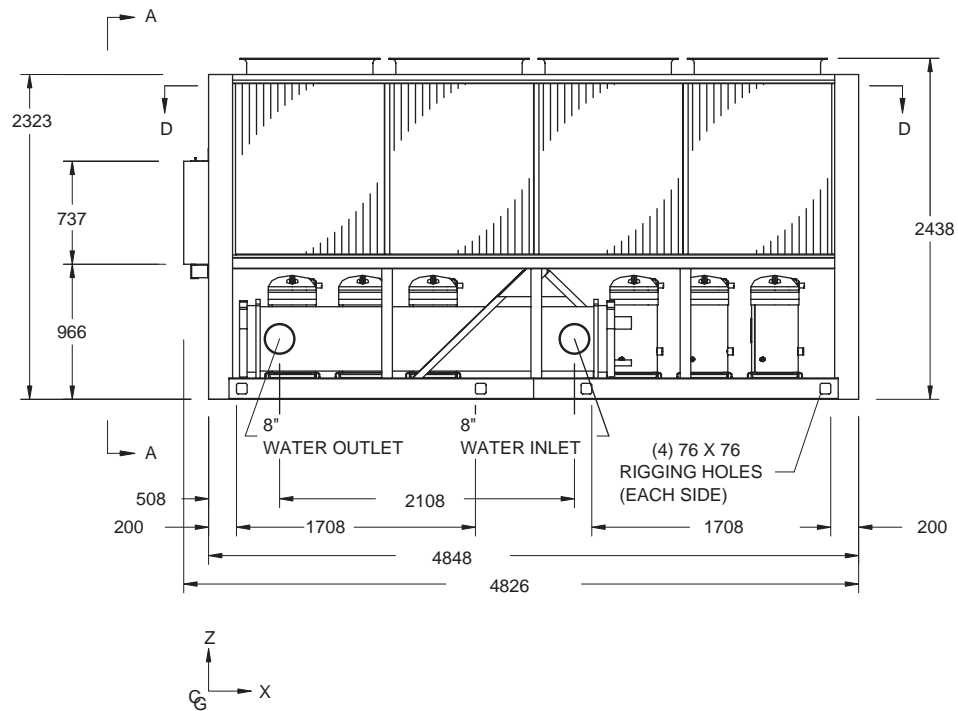
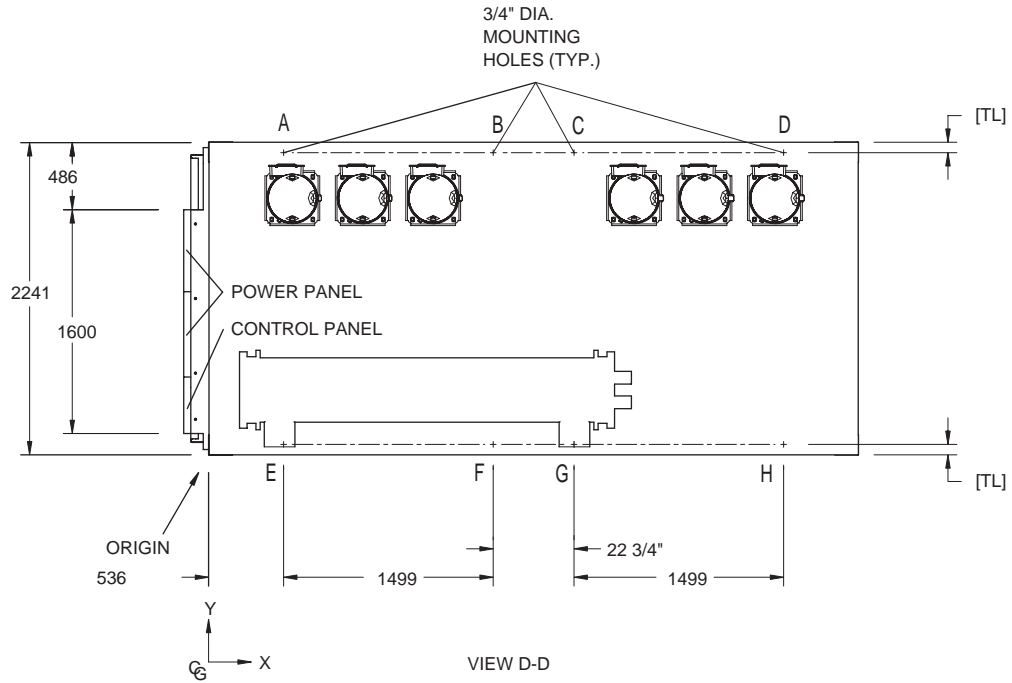

ALUMINUM

MODEL	CENTER OF GRAVITY (mm)			
	YCAL	X	Y	Z
0114	2017	1144	1053	
0124	2017	1144	1053	

COPPER

MODEL	CENTER OF GRAVITY (mm)			
	YCAL	X	Y	Z
0114	2055	1140	1105	
0124	2054	1140	1105	

PRE-STARTUP CHECKLIST

JOB NAME: _____
SALES ORDER #: _____
LOCATION: _____
SOLD BY: _____
INSTALLING CONTRACTOR: _____
START-UP TECHNICIAN/ COMPANY: _____
START-UP DATE : _____

CHILLER MODEL #: _____
SERIAL #: _____

CHECKING THE SYSTEM PRIOR TO INITIAL START (NO POWER)

Unit Checks

- 1. Inspect the unit for shipping or installation damage.
- 2. Assure that all piping has been completed.
- 3. Visually check for refrigerant piping leaks.
- 4. Open suction line ball valve, discharge line ball valve, and liquid line valve for each system.
- 5. The compressor oil level should be maintained so that an oil level is visible in the sight glass. The oil level can only be tested when the compressor is running in stabilized conditions, guaranteeing that there is no liquid refrigerant in the lower shell of the compressor. In this case, the oil should be between 1/4 and 3/4 in the sight glass. At shutdown, the oil level can fall to the bottom limit of the oil sight glass.
- 6. Assure water pumps are on. Check and adjust water pump flow rate and pressure drop across the cooler (see LIMITATIONS). Verify flow switch operation.

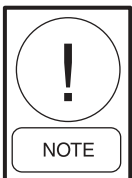

Excessive flow may cause catastrophic damage to the evaporator.

- 7. Check the control panel to ensure it is free of foreign material (wires, metal chips, etc.).
- 8. Visually inspect wiring (power and control). Wiring MUST meet N.E.C. and local codes. See Figures 2- 5, pages 14 - 17.
- 9. Check tightness of power wiring inside the power panel on both sides of the motor contactors and overloads.
- 10. Check for proper size fuses in main and control circuits, and verify overload setting corresponds with RLA and FLA values in electrical tables.
- 11. Assure 120VAC Control Power to CTB2 has 15 amp minimum capacity. See Table 1, page 20.
- 12. Be certain all water temp sensors are inserted completely in their respective wells and are coated with heat conductive compound.
- 13. Assure that evaporator TXV bulbs are strapped onto the suction lines at 4 or 8 o'clock positions or suction temp. sensors if EEVs are installed.

COMPRESSOR HEATERS (POWER ON – 24 HOURS PRIOR TO START)

- 1. Apply 120VAC and verify its value between terminals 5 and 2 of CTB2. The voltage should be 120VAC +/- 10%.

Power must be applied 24 hours prior to start-up.

Each heater should draw approximately 0.5-1A.

PANEL CHECKS (POWER ON – BOTH UNIT SWITCH OFF)

- 1. Apply 3-phase power and verify its value. Voltage imbalance should be no more than 2% of the average voltage.
- 2. Apply 120VAC and verify its value on the terminal block in the Power Panel. Make the measurement between terminals 5 and 2 of CTB2. The voltage should be 120VAC +/- 10%.
- 3. Program/verify the Cooling Setpoints, Program Setpoints, and unit Options. Record the values below (see sections on Setpoints and Unit Keys for programming instruction).

TABLE 17 – SETPOINTS ENTRY LIST

OPTIONS	
Display Language	
Sys 1 Switch	
Sys 2 Switch	
Chilled Liquid	
* Ambient Control	
Local/Remote Mode	
Control Mode	
Display Units	
* Lead/Lag Control	
* Fan Control	
Manual Override	
Current Feedback	
** Soft Start	
** Unit Type	
** Refrigerant Type	
** Expansion Valve Type	
COOLING SETPOINTS	
Cooling Setpoint	
Range	
EMS-PWM Max. Setpoint	
PROGRAM	
Discharge Pressure Cutout	
Suct. Pressure Cutout	
Low Amb. Temp. Cutout	
Leaving Liquid Temp. Cutout	
Anti-Recycle Time	
Fan Control On Pressure	
Fan Differential Off Pressure	
Total # of Compressors	
* Number of Fans/System	
* Unit/Sys Voltage	
Unit ID	
* Sys 1 Superheat Setpoint	
* Sys 2 Superheat Setpoint	

* NOT ON ALL MODELS
** VIEWABLE ONLY

- ❑ 4. Put the unit into Service Mode (as described under the Control Service and Troubleshooting section) and cycle each condenser fan to ensure proper rotation.
- ❑ 5. Prior to this step, turn system 2 off (if applicable – refer to Option 2 under “Unit Keys” section for more information on system switches.) Connect a manifold gauge to system 1 suction and discharge service valves.

Place the Unit Switch in the control panel to the ON position. **As each compressor cycles on, ensure that the discharge pressure rises and the suction pressure decreases.** If this does not occur, the compressor being tested is operating in the reverse direction and must be corrected. After verifying proper compressor rotation, turn the Unit Switch to “OFF.”



The chilled liquid setpoint may need to be temporarily lowered to ensure all compressors cycle “on.”



This unit uses scroll compressors which can only operate in one direction. Failure to observe this will lead to compressor failure.

- ❑ 6. YCAL0040 - YCAL0124 units only – Turn system 1 off and system 2 on (refer to Option 2 under “UNIT KEYS” section for more information on system switches.)

Place the Unit Switch in the control panel to the ON position. **As each compressor cycles “on,” ensure that the discharge pressure rises and the suction pressure decreases.** If this does not occur, the compressor being tested is operating in the reverse direction and must be corrected. After verifying proper compressor rotation, turn the Unit Switch to “OFF.”

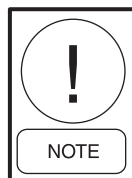

The chilled liquid setpoint may need to be temporarily lowered to ensure all compressors cycle “on.”

- ❑ 7. After verifying compressor rotation, return the Unit Switch to the off position and ensure that both Systems are programmed for “ON” (refer to Option 2 under “Unit Keys” section for more information on system switches).

INITIAL START-UP

After the preceding checks have been completed and the control panel has been programmed as required in the pre-startup checklist, the chiller may be placed into operation.

- ❑ 1. Place the Unit Switch in the control panel to the ON position.
- ❑ 2. The first compressor will start and a flow of refrigerant will be noted in the sight glass. After several minutes of operation, the vapor in the sight glass will clear and there should be a solid column of liquid when the TXV stabilizes.

- ❑ 3. Allow the compressor to run a short time, being ready to stop it immediately if any unusual noise or adverse conditions develop.
- ❑ 4. Check the system operating parameters. Do this by selecting various displays such as pressures and temperatures and comparing these readings to pressures and temperatures taken with manifold gauges and temperature sensors.
- ❑ 5. With an ammeter, verify that each phase of the condenser fans and compressors are within the RLA as listed under Electrical Data.

CHECKING SUPERHEAT AND SUBCOOLING

The subcooling and superheat should always be checked when charging the system with refrigerant.

When the refrigerant charge is correct, there will be no vapor in the liquid sight glass with the system operating under full load conditions, and there will be 15°F (8.34°C) subcooled liquid leaving the condenser.

An overcharged system should be guarded against. The temperature of the liquid refrigerant out of the condenser should be no more than 18°F (10°C) subcooled at design conditions.

The subcooling temperature of each system can be calculated by recording the temperature of the liquid line at the outlet of the condenser and subtracting it from the liquid line saturation temperature at the liquid stop valve (liquid line saturation temp. is converted from a temperature/pressure chart).

Example:

$$\begin{aligned}
 &\text{Liquid line pressure} = 102^\circ\text{F} \\
 &202 \text{ PSIG converted to } - 87^\circ\text{F} \\
 &\text{minus liquid line temp.} \\
 &\text{Subcooling} = 15^\circ\text{F}
 \end{aligned}$$

The subcooling should be adjusted to 15°F at design conditions.

- ❑ 1. Record the liquid line pressure and its corresponding temperature, liquid line temperature and subcooling below:

	SYS 1	SYS 2	
Liq Line Press =	_____	_____	PSIG
Saturated Temp =	_____	_____	°F
Liq Line Temp =	_____	_____	°F
Subcooling =	_____	_____	°F

After the subcooling is verified, the suction superheat should be checked. The superheat should be checked only after steady state operation of the chiller has been

established, the leaving water temperature has been pulled down to the required leaving water temperature, and the unit is running in a fully loaded condition. Correct superheat setting for a system is 10°F - 15°F (5.56°C - 8.33°C) 18" (46 cm) from the cooler.

Superheat should typically be set for no less than 10°F with only a single compressor running on a circuit. The superheat is calculated as the difference between the actual temperature of the returned refrigerant gas in the suction line entering the compressor and the temperature corresponding to the suction pressure as shown in a standard pressure/temperature chart.

Example:

$$\begin{aligned}
 &\text{Suction Temp} = 46^\circ\text{F} \\
 &\text{minus Suction Press} \\
 &60 \text{ PSIG converted to Temp} - 34^\circ\text{F} \\
 &\text{Superheat} = 12^\circ\text{F}
 \end{aligned}$$

When adjusting the expansion valve (TXV only), the adjusting screw should be turned not more than one turn at a time, allowing sufficient time (approximately 15 minutes) between adjustments for the system and the thermal expansion valve to respond and stabilize.



The EEV is non-adjustable. Superheat setpoint is programmable from the keypad.

Assure that superheat is set at a minimum of 10°F (5.56°C) with a single compressor running on each circuit.

- ❑ 2. Record the suction temperature, suction pressure, suction saturation temperature, and superheat of each system below:

	SYS 1	SYS 2	
Suction temp =	_____	_____	°F
Suction Pressure =	_____	_____	PSIG
Saturation Temp =	_____	_____	°F
Superheat =	_____	_____	°F

LEAK CHECKING

- ❑ 1. Leak check compressors, fittings, and piping to ensure no leaks.

If the unit is functioning satisfactorily during the initial operating period, no safeties trip and the compressors cycle to control water temperature to setpoint, the chiller is ready to be placed into operation.

UNIT OPERATING SEQUENCE

The operating sequence described below relates to operation on a hot water start after power has been applied, such as start-up commissioning. When a compressor starts, internal timers limit the minimum time before another compressor can start to 1 minute.

1. For the chiller system to run, the Flow Switch must be closed, any remote cycling contacts must be closed, the Daily Schedule must not be scheduling the chiller off, and temperature demand must be present.
2. When power is applied to the system, the microprocessor will start a 2 minute timer. This is the same timer that prevents an instantaneous start after a power failure.
3. At the end of the 2 minute timer, the microprocessor will check for cooling demand. If all conditions allow for start, a compressor on the lead system will start and the liquid line solenoid will open or the EEV will begin to operate (EEV equipped chillers only). Coincident with the start, the anti-coincident timer will be set and begin counting downward from "60" seconds to "0" seconds.

If the unit is programmed for Auto Lead/Lag, the system with the shortest average run-time of the compressors will be assigned as the "lead" system. A new lead/lag assignment is made whenever all systems shut down.

4. Several seconds after the compressor starts, that systems first condenser fan will be cycled on (out-

door air temperature > 25°F (-4°C) or discharge pressure). See the section on Operating Controls for details concerning condenser fan cycling. YCAL0090 – YCAL0124 cycle fans on discharge pressure only.

5. After 1 minute of compressor run time, the next compressor in sequence will start when a system has to load. Additional compressors will be started at 60 second intervals as needed to satisfy temperature setpoint.
6. If demand requires, the lag system will cycle on with the same timing sequences as the lead system after the lead system has run for five minutes. Refer to the section on Capacity Control for a detailed explanation of system and compressor staging.
7. As the load decreases below setpoint, the compressors will be shut down in sequence. This will occur at intervals of either 60, 30, or 20 seconds based on water temperature as compared to setpoint, and control mode. See the section on Capacity Control for a detailed explanation.
8. When the last compressor in a "system" (two or three compressors per system), is to be cycled off, the system will initiate a pump-down. Each "system" has a pump-down feature upon shut-off. On a non-safety, non-unit switch shutdown, the LLSV will be turned off or the EEV will close (EEV equipped chillers only), and the last compressor will be allowed to run until the suction pressure falls below the suction pressure cutout or for 180 seconds, whichever comes first.

UNIT CONTROLS YORK MILLENNIUM CONTROL CENTER

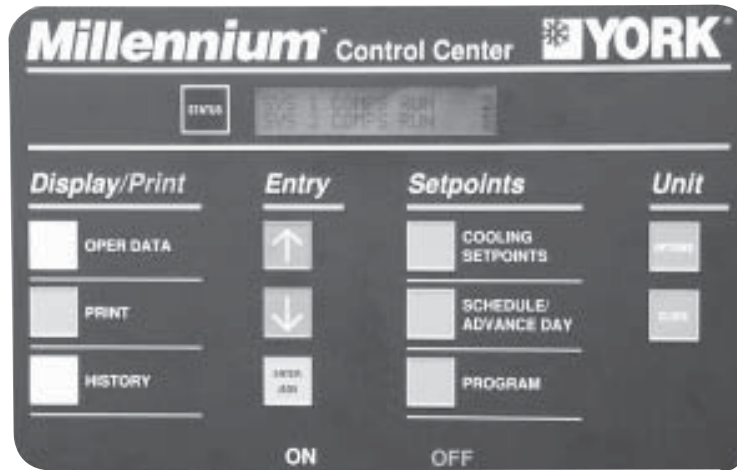

00065VIP

INTRODUCTION

The YORK MicroComputer Control Center is a microprocessor based control system designed to provide the entire control for the liquid chiller. The control logic embedded in the microprocessor based control system will provide control for the chilled liquid temperatures, as well as sequencing, system safeties, displaying status, and daily schedules. The MicroComputer Control Center consists of four basic components, 1) microprocessor board, 2) transformer, 3) display and 4) keypad. The keypad allows programming and accessing setpoints, pressures, temperatures, cutouts, daily schedule, options, and fault information.

Remote cycling, demand limiting and chilled liquid temperature reset can be accomplished by field supplied contacts.

Compressor starting/stopping and loading/unloading decisions are performed by the Microprocessor to maintain leaving or return chilled liquid temperature. These decisions are a function of temperature deviation from setpoint.

A Master ON/Off switch is available to activate or deactivate the unit.

MICROPROCESSOR BOARD

The Microprocessor Board is the controller and decision maker in the control panel. System inputs such as pressure transducers and temperature sensors are connected directly to the Microprocessor Board. The Microprocessor Board circuitry multiplexes the analog inputs, digitizes them, and scans them to keep a constant watch on the chiller operating conditions. From this information, the Microprocessor then issues commands to the Relay Outputs to control contactors, solenoids, etc. for Chilled Liquid Temperature Control and to react to safety conditions.

Keypad commands are acted upon by the micro to change setpoints, cutouts, scheduling, operating requirements, and to provide displays.

The on-board power supply converts 24VAC from the 1T transformer to a +12VDC and +5VDC regulated supply located on the Microprocessor Board. This voltage is used to operate integrated circuitry on the board. The 40 character display and unit sensors are supplied power from the microboard 5VDC supply.

24VAC is rectified and filtered to provide unregulated +30VDC to supply the flow switch, PWM remote temperature reset, and demand limit circuitry which is available to be used with field supplied contacts.

The Microprocessor Board energizes on-board relays to output 120VAC to motor contactors, solenoid valves, etc. to control system operation. It also energizes solid state relays to output 24VAC to the EEVs if installed.

UNIT SWITCH

A UNIT ON/OFF switch is just underneath the keypad. This switch allows the operator to turn the entire unit OFF if desired. The switch must be placed in the ON position for the chiller to operate.

DISPLAY

The 40 Character Display (2 lines of 20 characters) is a liquid crystal display used for displaying system parameters and operator messages.

The display in conjunction with the keypad, allows the operator to display system operating parameters as well as access programmed information already in memory. The display has a lighted background for night viewing and for viewing in direct sunlight.

When a key is pressed, such as the OPER DATA key, system parameters will be displayed and will remain on the display until another key is pressed. The system parameters can be scrolled with the use of the up and down arrow keys. The display will update all information at a rate of about 2 seconds.

Display Messages may show characters indicating "greater than" (>) or "less than" (<). These characters indicate the actual values are greater than or less than the limit values which are being displayed.

KEYPAD

The 12 button non-tactile keypad allows the user to retrieve vitals system parameters such as system pressures, temperatures, compressor running times and starts, option information on the chiller, and system setpoints. This data is useful for monitoring chiller operation, diagnosing potential problems, troubleshooting, and commissioning the chiller.

It is essential the user become familiar with the use of the keypad and display. This will allow the user to make full use of the capabilities and diagnostic features available.

BATTERY BACK-UP

The Microprocessor Board contains a Real Time Clock integrated circuit chip with an internal battery backup. The purpose of this battery backup is to assure any programmed values (setpoints, clock, cutouts, etc.) are not lost during a power failure regardless of the time involved in a power cut or shutdown period.

UNIT STATUS

Pressing the STATUS key will enable the operator to determine current chiller operating status. The messages displayed will include running status, cooling demand, fault status, external cycling device status, load limiting and anti-recycle/coincident timer status. The display will be a single message relating to the highest priority message as determined by the micro. Status messages fall into the categories of General Status and Fault Status.

“STATUS” KEY

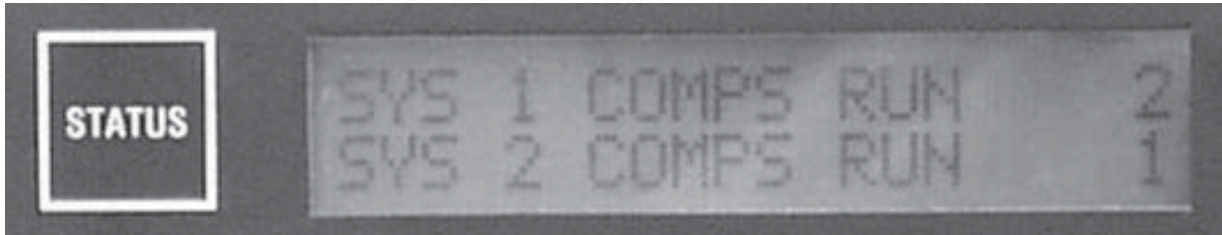

00066VIP

The following messages are displayed when the “Status” key is pressed. Following each displayed message is an explanation pertaining to that particular display.

GENERAL STATUS MESSAGES

In the case of messages which apply to individual systems, SYS 1 and SYS 2 messages will both be displayed and may be different. In the case of single system units, all SYS 2 messages will be blank.

**UNIT SWITCH OFF
SHUTDOWN**

This message informs the operator that the UNIT switch on the control panel is in the OFF position which will not allow the unit to run.

**REMOTE CONTROLLED
SHUTDOWN**

The REMOTE CONTROLLED SHUTDOWN message indicates that either an ISN system or RCC has turned the unit off, not allowing it to run.

**DAILY SCHEDULE
SHUTDOWN**

The DAILY SCHEDULE SHUTDOWN message indicates that the daily/holiday schedule programmed is keeping the unit from running.

**FLOW SWITCH / REM STOP
NO RUN PERM**

NO RUN PERM shows that either the flow switch is open or a remote start/stop contact is open in series with the flow switch. A 3-second delay is built into the software to prevent nuisance shutdowns due to erroneous signals on the run permissive input.

```

SYS 1 SYS SWITCH OFF
SYS 2 SYS SWITCH OFF

```

SYS SWITCH OFF tells that the system switch under OPTIONS is turned off. The system will not be allowed to run until the switch is turned back on.

```

SYS 1 NO COOL LOAD
SYS 2 NO COOL LOAD

```

This message informs the operator that the chilled liquid temperature is below the point (determined by the setpoint and control range) that the micro will bring on a system or that the micro has not loaded the lead system far enough into the loading sequence to be ready to bring the lag system ON. The lag system will display this message until the loading sequence is ready for the lag system to start.

```

SYS 1 COMPS RUN X
SYS 2 COMPS RUN X

```

The COMPS RUNNING message indicates that the respective system is running due to demand. The "X" will be replaced with the number of compressors in that system that are running.

```

SYS 1 AR TIMER XX S
SYS 2 AR TIMER XX S

```

The anti-recycle timer message shows the amount of time left on the respective systems anti-recycle timer. This message is displayed when the system is unable to start due the anti-recycle timer being active.

```

SYS 1 AC TIMER XX S
SYS 2 AC TIMER XX S

```

The anti-coincidence timer is a software feature that guards against 2 systems starting simultaneously. This assures instantaneous starting current does not become excessively high due to simultaneous starts. The micro limits the time between compressor starts to 1 minute regardless of demand or the anti-recycle timer being timed out. The anti-coincidence timer is only present on two system units.

```

SYS 1 DSCH LIMITING
SYS 2 DSCH LIMITING

```

When this message appears, discharge pressure limiting is in effect. The Discharge Pressure Limiting feature is integral to the standard software control; however the discharge transducer is optional on some models. Therefore, it is important to keep in mind that this control will not function unless the discharge transducer is installed in the system.

The limiting pressure is a factory set limit to keep the system from faulting on the high discharge pressure cutout due to high load or pull down conditions. When the unload point is reached, the micro will automatically unload the affected system by deenergizing one compressor. The discharge pressure unload will occur when the discharge pressure gets within 15 PSIG of the programmed discharge pressure cutout. This will only happen if the system is fully loaded and will shut only one compressor off. If the system is not fully loaded, discharge limiting will not go into effect. Reloading the affected system will occur when the discharge pressure drops to 85% of the unload pressure and 10 minutes have elapsed.

2

```
SYS 1 SUCT LIMITING
SYS 2 SUCT LIMITING
```

When this message appears, suction pressure limiting is in effect. Suction Pressure Limiting is only available on units that have the suction pressure transducer installed. If a low pressure switch is installed instead, suction pressure limiting will not function.

The suction pressure limit is a control point that limits the loading of a system when the suction pressure drops to within 15% above the suction pressure cutout. On a standard system programmed for 44 PSIG/3.0 Bar suction pressure cutout, the micro would inhibit loading of the affected system with the suction pressure less than or equal to $1.15 * 44 \text{ PSIG/3.0 Bar} = 50 \text{ PSIG/3.5 Bar}$. The system will be allowed to load after 60 seconds and after the suction pressure rises above the suction pressure limit point.

```
SYS 1 LOAD LIMIT XX%
SYS 2 LOAD LIMIT XX%
```

This message indicates that load limiting is in effect and the percentage of the limiting in effect. This limiting could be due to the load limit/pwm input, ISN or RCC controller could be sending a load limit command.

```
MANUAL
OVERRIDE
```

If MANUAL OVERRIDE mode is selected, the STATUS display will display this message. This will indicate that the Daily Schedule is being ignored and the chiller will start-up when chilled liquid temperature allows, Remote Contacts, UNIT switch and SYSTEM switches permitting. This is a priority message and cannot be overridden by anti-recycle messages, fault messages, etc. when in the STATUS display mode. Therefore, do not expect to see any other STATUS messages when in the MANUAL OVERRIDE mode. MANUAL OVERRIDE is to only be used in emergencies or for servicing. Manual override mode automatically disables itself after 30 minutes.

```
SYS 1 PUMPING DOWN
SYS 2 PUMPING DOWN
```

The PUMPING DOWN message indicates that a compressor in the respective system is presently in the process of pumping the system down. When pumpdown is initiated on shutdown, the liquid line solenoid or EEV will close and a compressor will continue to run. When the suction pressure decreases to the suction pressure cutout setpoint or runs for 180 seconds, whichever comes first, the compressor will cycle off.

FAULT STATUS MESSAGES

Safeties are divided into two categories – system safeties and unit safeties. System safeties are faults that cause the individual system to be shut down. Unit safeties are faults that cause all running compressors to be shut down. Following are display messages and explanations.

System Safeties:

System safeties are faults that cause individual systems to be shut down if a safety threshold is exceeded for 3 seconds. They are auto reset faults in that the system will be allowed to restart automatically after the fault condition is no longer present. However, if 3 faults on the same system occur within 90 minutes, that system will be locked out on the last fault. This condition is then a manual reset. The system switch (under OPTIONS key) must be turned off and then back on to clear the lockout fault.

```
SYS 1 HIGH DSCH PRES
SYS 2 HIGH DSCH PRES
```

The Discharge Pressure Cutout is a software cutout in the microprocessor and is backed-up by a mechanical high pressure cutout switch located in the refrigerant circuit. It assures that the system pressure does not exceed safe working limits. The system will shutdown when the programmable cutout is exceeded and will be allowed to restart when the discharge pressure falls 40 PSIG below the cutout. *Discharge transducers must be installed for this function to operate.*

```
SYS 1 LOW SUCT PRESS
SYS 2 LOW SUCT PRESS
```

The Suction Pressure Cutout is a software cutout that helps protect the chiller from an evaporator freeze-up should the system attempt to run with a low refrigerant charge or a restriction in the refrigerant circuit.

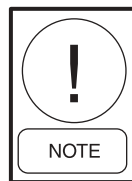

Repeated starts after resetting a low suction pressure fault will cause evaporator freeze-up. Whenever a system locks out on this safety, immediate steps should be taken to identify the cause.

At system start, the cutout is set to 10% of programmed value. During the next 3 minutes the cutout point is ramped up to the programmed cutout point. If at any time during this 3 minutes the suction pressure falls below the ramped cutout point, the system will stop.

This cutout is ignored for the first 30 seconds of system run time to avoid nuisance shutdowns, especially on units that utilize a low pressure switch in place of the suction pressure transducer.

After the first 3 minutes, if the suction pressure falls below the programmed cutout setting, a “transient protection routine” is activated. This sets the cutout at 10% of the programmed value and ramps up the cutout over the next 30 seconds. If at any time during this 30 seconds the suction pressure falls below the ramped cutout, the system will stop. This transient protection scheme only works if the suction pressure transducer is installed. When using the mechanical LP switch, the operating points of the LP switch are: opens at 23 PSIG +/- 5 PSIG (1.59 barg +/- .34 barg), and closes at 35 PSIG +/- 5 PSIG (2.62 barg +/- .34 barg).

```
SYS 1 MP / HPCO FAULT
SYS 2 MP / HPCO FAULT
```

The Motor Protector/Mechanical High Pressure Cutout protect the compressor motor from overheating or the system from experiencing dangerously high discharge pressure. This fault condition is present when CR1 (SYS 1) or CR2 (SYS 2) relays de-energize due to the HP switch or motor protector opening. This causes the respective CR contacts to open causing 0VDC to be read on the inputs to the microboard. The fault condition is cleared when a 30VDC signal is restored to the input.

The internal motor protector opens at 185°F - 248°F (85°C - 120°C) and auto resets. The mechanical HP switch opens at 405 PSIG +/- 10 PSIG (27.92 barg +/- .69 barg) and closes at 330 PSIG +/- 25 PSIG (22.75 barg +/- 1.72 barg).

```
SYS 1 HIGH MTR CURR
SYS 2 HIGH MTR CURR
```

When System Current Feedback option is selected (Option 11 under OPTIONS Key Current Feedback), this safety will operate as follows. If the actual voltage of the system exceeds the programmed trip voltage for 5 seconds, the system will shutdown. This fault will not be cleared until the condition is no longer present.

```
SYS 1 LOW EVAP TEMP
SYS 2 LOW EVAP TEMP
```

The Low Evaporator Temperature Cutout is to protect the evaporator from freeze-up with R-407C. This safety

uses the Cooler Inlet Refrigerant Temp Sensors to monitor evaporator inlet refrigerant temperature on each system. These sensors are only installed on R-407C units. This safety is ignored for the first 270 seconds of runtime.

In water cooling mode, if the refrigerant temperature falls below 21°F, the system will be shut down.

In glycol cooling mode, if the refrigerant temp. is below 21°F and falls 19°F below the leaving chilled liquid temp., the system will shut down.

In either cooling mode, if the cooler inlet refrigerant temp. sensor reads out of range low, the system will also shut down.

```
SYS 1 LOW SUPERHEAT
SYS 2 LOW SUPERHEAT
```

The Low Superheat Cutout is to protect the compressor(s) from liquid floodback due to low suction superheat. This safety is only active when EEV is selected as the expansion valve in SERVICE Mode. This safety is ignored for the first 15 seconds of system runtime.

This safety can be triggered by two events. The first is when suction superheat <2.0°F for 3 seconds. The second is when the EEV pilot solenoid is closed 10 times in 2 minutes due to low superheat.

```
SYS 1 SENSOR FAILURE
SYS 2 SENSOR FAILURE
```

The Sensor Failure Safety prevents the system from running when the sensors measuring superheat are not functioning properly. This safety is only active when EEV is selected as the expansion valve type in SERVICE Mode. This safety is ignored for the first 15 seconds of system runtime.

This safety will shut down a system if either suction temperature or suction pressure sensors read out of range high or low. This condition must be present for 3 seconds to cause a system shutdown. The safety locks out a system after the first fault and will not allow automatic restarting.

Unit Safeties:

Unit safeties are faults that cause all running compressors to be shut down. Unit faults are auto reset faults in that the unit will be allowed to restart automatically after the fault condition is no longer present.

**UNIT FAULT :
LOW AMBIENT TEMP**

The Low Ambient Temp Cutout is a safety shutdown designed to protect the chiller from operating in a low ambient condition. If the outdoor ambient temperature falls below the programmable cutout, the chiller will shut down. Restart can occur when temperature rises 2°F above the cutoff.

**UNIT FAULT :
LOW LIQUID TEMP**

The Low Leaving Chilled Liquid Temp Cutout protects the chiller from an evaporator freeze-up should the chilled liquid temperature drop below the freeze point. This situation could occur under low flow conditions or if the micro panel setpoint values are improperly programmed. Anytime the leaving chilled liquid temperature (water or glycol) drops below the cutout point, the chiller will shutdown. Restart can occur when chilled liquid temperature rises 2°F above the cutout.

**UNIT FAULT :
115VAC UNDER VOLTAGE**

The Under Voltage Safety assures that the system is not operated at voltages where malfunction of the microprocessor could result in system damage. When the 115VAC to the micro panel drops below a certain level, a unit fault is initiated to safely shut down the unit. Restart is allowed after the unit is fully powered again and the anti-recycle timers have finished counting down.

**UNIT FAULT :
HIGH MTR CURR**

When the CURRENT FEEDBACK ONE PER UNIT option is selected under the OPTIONS Key, the unit will shut down when the voltage exceeds the programmed trip voltage for 5 seconds.

The trip voltage is programmed at the factory according to compressor or unit RLA.

Restart will occur after the anti-recycle timer times out.

UNIT WARNING

The following messages are not unit safeties and will not be logged to the history buffer. They are *unit warnings* and will not auto-restart. Operator intervention is required to allow a restart of the chiller.

**!! LOW BATTERY !!
CHECK PROG / SETP / OPTN**

The Low Battery Warning can only occur at unit power-up. On micro panel power-up, the RTC battery is checked. If a low battery is found, all programmed setpoints, program values, options, time, schedule, and history buffers will be lost. These values will all be reset to their default values which may not be the desired operating values. Once a faulty battery is detected, the unit will be prevented from running until the PROGRAM key is pressed. Once PROGRAM is pressed the anti-recycle timers will be set to the programmed anti-recycle time to allow the operator time to check setpoints, and if necessary, reprogram programmable values and options.

If a low battery is detected, it should be replaced as soon as possible. The programmed values will all be lost and the unit will be prevented from running on the next power interruption. The RTC/battery is located at U17 on the microboard.

**INCORRECT
UNIT TYPE**

This indicates the condensing unit jumper is installed between J4-11 and J4-6, on a liquid chiller. This jumper must be removed to operate the chiller.

STATUS KEY MESSAGES

TABLE 18 – STATUS KEY MESSAGES

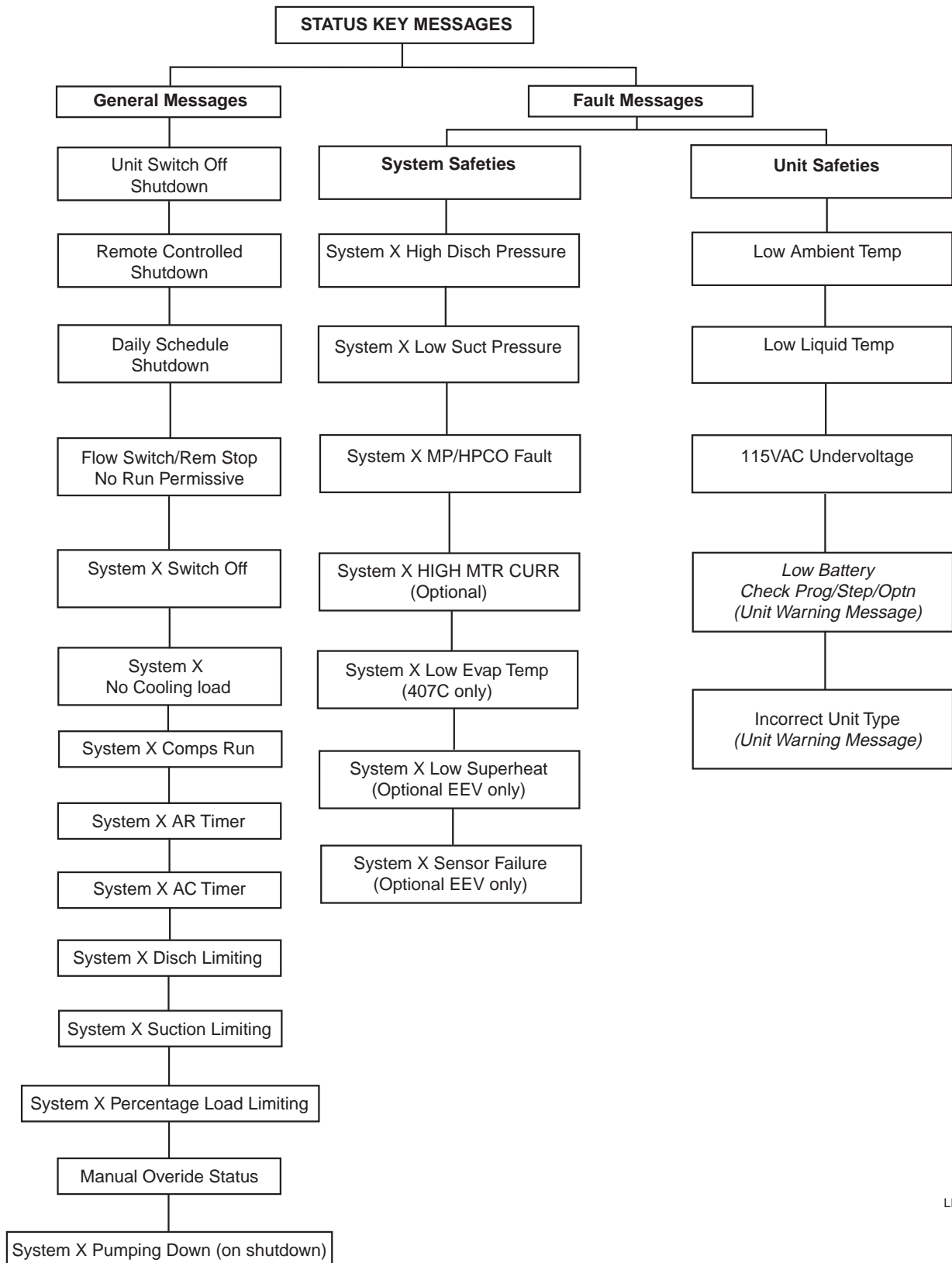

2

LD07380

DISPLAY/PRINT KEYS

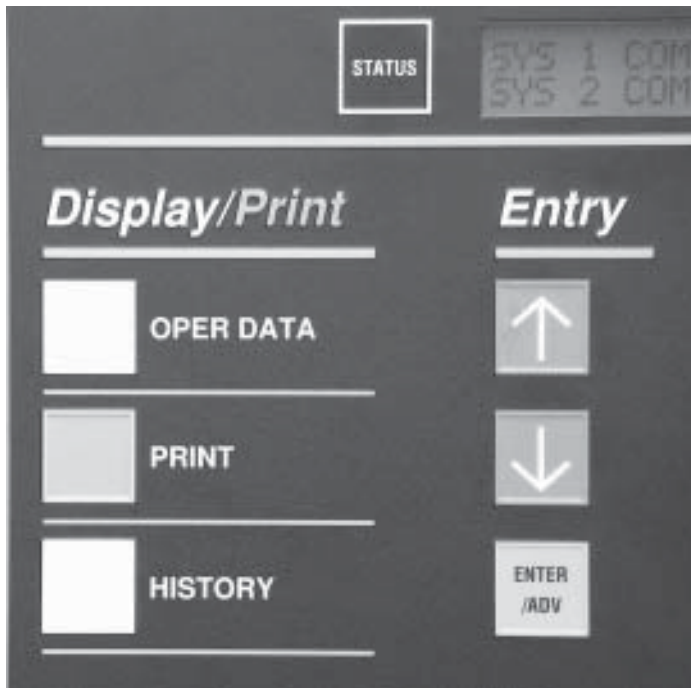

00067VIP

The Display/Print keys allow the user to retrieve system and unit information that is useful for monitoring chiller operation, diagnosing potential problems, troubleshooting, and commissioning the chiller.

System and unit information, unit options, setpoints, and scheduling can also be printed out with the use of a printer. Both real-time and history information are available.

OPER DATA Key

The OPER DATA key gives the user access to unit and system operating parameters. When the OPER DATA key is pressed, system parameters will be displayed and remain on the display until another key is pressed. After pressing the OPER DATA key, the various operating data screens can be scrolled through by using the UP and DOWN arrow keys located under the “ENTRY” section.

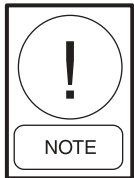

System 2 information will only be displayed for 2 system units.

With the “UNIT TYPE” set as a liquid chiller (via no jumper between J4-11 and J4-6), the following list of operating

data screens are viewable under the Oper Data key in the order that they are displayed. The ↓ arrow key scrolls through the displays in the order they appear below:

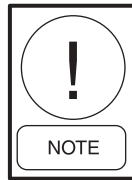

The chiller MUST be set to be a liquid chiller via no jumper between J4-11 and J4-6. DO NOT operate the chiller if not properly set up.

L C H L T = 4 6 . 2 ° F
R C H L T = 5 7 . 4 ° F

This display shows chilled leaving and return liquid temperatures. The minimum limit on the display for these parameters are 9.2°F (-12.7°C). The maximum limit on the display is 140°F (60°C).

A M B I E N T A I R T E M P
= 8 7 . 5 ° F

This display shows the ambient air temperature. The minimum limit on the display is 0.4°F (-17.6°C). The maximum limit on the display is 131.2°F (55.1°C).

```
S Y S X S P = 7 2 . 1 P S I G
      D P = 2 2 7 . 0 P S I G
```

These displays show suction and discharge pressures for each system. The discharge pressure transducer is optional on some models.

If the *optional* discharge transducer is not installed, the discharge pressure would display 0 PSIG (0 barg).

Some models come factory wired with a low pressure switch in place of the suction transducer. In this case, the suction pressure would only be displayed as the maximum suction pressure reading of >200 PSIG (13.79 barg) when closed, or < 0 PSIG (0 barg) when open.

The minimum limits for the display are:
Suction Pressure: 0 PSIG (0 barg)
Discharge Pressure: 0 PSIG (0 barg)

The maximum limits for the display are:
Suction Pressure: 200 PSIG (13.79 barg)
Discharge Pressure: 400 PSIG (27.58 barg)

```
S Y S X S U C T = X X X . X ° F
      S A T S U C T = X X X . X ° F
```

```
S Y S X E E V = X X X . X %
      S U C T S H E A T = X X X . X ° F
```

These messages will be displayed for each system, if an EEV is installed in the system. The EEV % is the EEV controller output.

```
S Y S X C O O L E R I N L E T
      R E F R I G T E M P = X X X . X ° F
```

Cooler inlet temperatures, as measured by the refrigerant temperature sensor in the cooler, will be displayed on R-407c units for both systems.

```
S Y S X H O U R S 1 = X X X X X
      2 = X X X X X, 3 = X X X X X
```

```
S Y S X S T A R T S 1 = X X X X X
      2 = X X X X X, 3 = X X X X X
```

The above two messages will appear sequentially for each system. The first display shows accumulated running hours of each compressor for the specific system. The second message shows the number of starts for each compressor on each system.



Run times and starts will only be displayed for the actual number of systems and compressors on the unit.

```
L O A D T I M E R 5 8 S E C
U N L O A D T I M E R 0 S E C
```

This display of the load and unload timers indicate the time in seconds until the unit can load or unload. Whether the systems loads or unloads is determined by how far the actual liquid temperature is from set-point. A detailed description of unit loading and unloading is covered under the topic of Capacity Control.

```
C O O L I N G D E M A N D
      2 O F 8 S T E P S
```

The display of COOLING DEMAND indicates the current “step” in the capacity control scheme when in Return Water Control Mode. The number of available steps are determined by how many compressors are in the unit. In the above display, the “2” does not mean that two compressor are running but only indicates that the capacity control scheme is on step 2 of 8. Capacity Control is covered in more detail in this publication which provides specific information on compressor staging (for Return Water Control only).

```
T E M P E R R O R X X X . X ° F
T E M P R A T E X X X . X ° F / M
```

The COOLING DEMAND message will be replaced with this message when Leaving Chilled liquid control is selected. This message indicates the temperature error and the rate of change of the chilled liquid temperature.

LEAD SYSTEM IS
SYSTEM NUMBER 2

This display indicates the current LEAD system. In this example system 2 is the LEAD system, making system 1 the LAG system. The LEAD system can be manually selected or automatic. Refer to the programming under the "OPTIONS" key. The Lead System display will only appear on a two system unit.

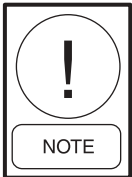

A unit utilizing hot gas bypass should be programmed for MANUAL with system 1 as the lead system. Failure to do so will prevent hot gas operation if system 2 switches to the lead system when programmed for AUTOMATIC LEAD/LAG.

EVAP PUMP IS ON
EVAP HEATER IS OFF

This display indicates the status of the evaporator pump contacts and the evaporator heater.

The evaporator pump dry contacts are energized when any compressor is running, or the unit is not OFF on the daily schedule and the unit switch is on, or the unit has shutdown on a Low Leaving Chilled Liquid fault. However, even if one of above is true, the pump will not run if the micro panel has been powered up for less than 30 seconds or if the pump has run in the last 30 seconds to prevent pump motor overheating.

The evaporator heater is controlled by ambient air temperature. When the ambient temperature drops below 40°F the heater is turned on. When the temperature rises above 45°F the heater is turned off. An under voltage condition will keep the heater off until full voltage is restored to the system.

ACTIVE REMOTE CTRL
NONE

There are several types of remote systems that can be used to control or monitor the unit. The following messages indicate the type of remote control mode active:

NONE – no remote control active. Remote monitoring may be via ISN.

ISN – York Talk via ISN allows remote load limiting and temperature reset through an ISN system.

*LOAD LIM – load limiting enabled. Can be either stage 1 or stage 2 of limiting.

*PWM TEMP – EMS-PWM temperature reset

*Refer to the section on OPERATING CONTROLS

If the micro is programmed for CURRENT FEEDBACK ONE PER UNIT under the OPTIONS Key, the display will show up as the first display prior to the SYS 1 displays. Total chiller current is displayed as shown below:

UNIT AMPS = 54.0
VOLTS = 1.2

If the micro is programmed for CURRENT FEEDBACK NONE, no current display will appear.

SYS X COMP STATUS
1 = XXX 2 = XXX 3 = XXX

SYS X RUN TIME
XX - XX - XX - XX D - H - M - S

SYS X LLSV IS ON
HOT GAS SOL IS OFF

SYS X FAN STAGE 3

SYS X AMPS = 36.0
VOLTS = 0.8

The preceding five messages will appear sequentially, first for system 1, then for system 2.

The first message indicates the system and the associated compressors which are running.

The second message indicates the system run time in days – hours – minutes – seconds. Please note that this is not accumulated run time but pertains only to the current system cycle.

The third message indicates the system, and whether the liquid line solenoid or EEV pilot solenoid and hot gas solenoid are being turned on by the microboard. Please note that hot gas in not available for system 2, so there is no message pertaining to the hot gas solenoid when system 2 message is displayed.

The fourth message indicates what stage of condenser fan operation is active. For YCAL0014 to YCAL0080 unless a low ambient kit is added, only stages 1 and 3 will be used to cycle the condenser fans. However, stage 2 may be shown in this display without a low ambient kit added, but it has no effect. YCAL0090 - YCAL0124 have 3 or 4 fan stages as standard.

See the section on Condenser Fan Control in the UNIT OPERATION section for more information.

The fifth message displays current as sensed by the optional current feedback circuitry. The display reads out in amps along with the DC feedback voltage from the module. Current is calculated by $\frac{225A \bullet \text{Actual Volts}}{5 \text{ Volts}}$

Individual displays will be present for each system, if CURRENT FEEDBACK ONE PER SYSTEM is programmed under the OPTIONS Key. Combined compressor current for each system is displayed.

OPER DATA Quick Reference List

The following table is a quick reference list for information available under the OPER DATA key.

TABLE 19 – OPERATION DATA

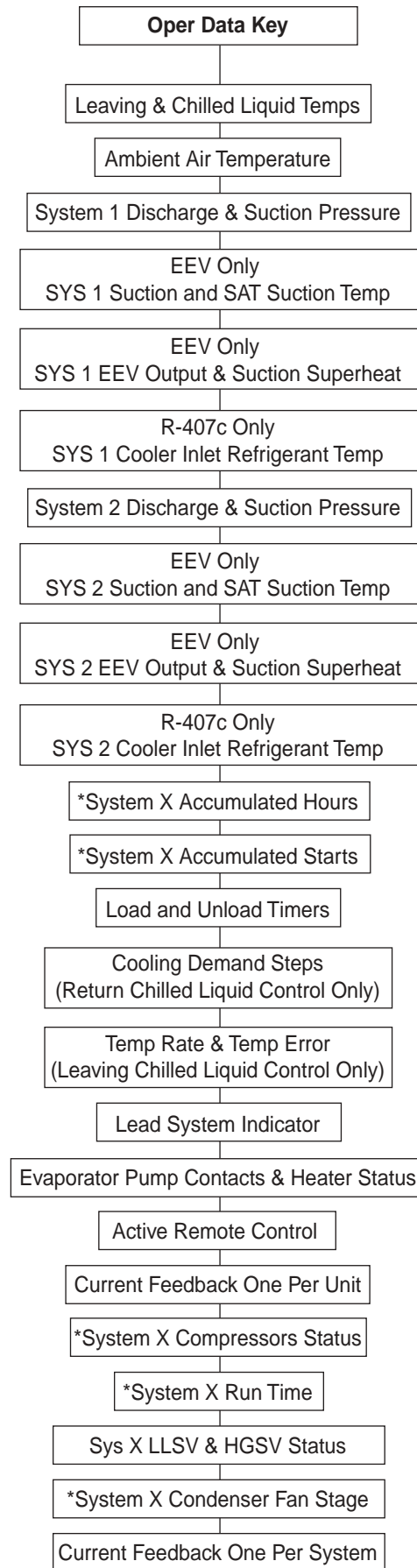

* Block of information repeats for each system

PRINT Key

The PRINT key allows the operator to obtain a printout of real-time system operating data or a history printout of system data at the “instant of the fault” on the last six faults which occurred on the unit. An optional printer is required for the printout.

OPERATING DATA PRINTOUT

Pressing the PRINT key and then OPER DATA key allows the operator to obtain a printout of current system operating parameters. When the OPER DATA key is pressed, a snapshot will be taken of system operating conditions and panel programming selections. This data will be temporarily stored in memory and transmission of this data will begin to the printer. A sample Operating Data printout is shown below. (Note: Not all values are printed for all models.)

```

YORK INTERNATIONAL CORPORATION
MILLENNIUM LIQUID CHILLER

UNIT STATUS
2:04PM 01 JAN 02

SYS 1          NO COOLING LOAD
SYS 2          COMPRESSORS RUNNING 2

OPTIONS
CHILLED LIQUID          WATER
AMBIENT CONTROL         STANDARD
LOCAL/REMOTE MODE      REMOTE
CONTROL MODE            LEAVING LIQUID
LEAD/LAG CONTROL        AUTOMATIC
FAN CONTROL             AMB & DSCH PRESS
CURRENT FEEDBACK        NONE
SOFT START              ENABLED
EXPANSION VALVE         THERMOSTATIC

PROGRAM VALUES
DSCH PRESS CUTOUT      395 PSIG
SUCT PRESS CUTOUT      44 PSIG
LOW AMBIENT CUTOUT     25.0 DEGF
LEAVING LIQUID CUTOUT  36.0 DEGF
ANTI RECYCLE TIME      600 SECS
FAN CONTROL ON PRESS   240 PSIG
FAN DIFF OFF PRESS     80 PSIG
NUMBER OF COMPRESSORS  6
NUMBER OF FANS PER SYSTEM 4
UNIT TRIP VOLTS        3.0
REFRIGERANT TYPE       R-22
REMOTE UNIT ID PROGRAMMED 2

UNIT DATA
RETURN LIQUID TEMP     58.2 DEGF
    
```

```

LEAVING LIQUID TEMP     53.0 DEGF
COOLING RANGE           42.0 +/- 2.0 DEGF
AMBIENT AIR TEMP        74.8 DEGF
LEAD SYSTEM             SYS 2
EVAPORATOR PUMP         ON
EVAPORATOR HEATER       OFF
ACTIVE REMOTE CONTROL   NONE
UNIT XXX.X AMPS         X.X VOLTS
SOFTWARE VERSION        C.MMC.03.03
    
```

SYSTEM 1 DATA

```

COMP STATUS             1=OFF 2=OFF 3=OFF
RUN TIME                0- 0- 0- 0 D-H-M-S
SUCTION PRESSURE        66 PSIG
DISCHARGE PRESSURE      219 PSIG
SUCTION TEMPERATURE     52.8 DEGF
SAT SUCTION TEMP        40.0 DEGF
SUCTION SUPERHEAT       12.8 DEGF
COOLER INLET REFRIG     31.6 DEGF
LIQUID LINE SOLENOID    OFF
HOT GAS BYPASS VALVE    OFF
CONDENSER FAN STAGES    OFF
EEV OUTPUT              0.0 %
SYSTEM                  XXX.X AMPS X.X VOLTS
    
```

SYSTEM 2 DATA

```

COMP STATUS             1=OFF, 2=OFF, 3=OFF
SUCTION PRESSURE        51 PSIG
DISCHARGE PRESSURE      157 PSIG
SUCTION TEMPERATURE     44.3 DEGF
SAT SUCTION TEMP        32.1 DEGF
SUCTION SUPERHEAT       12.2 DEGF
COOLER INLET REFRIG     31.6 DEGF
LIQUID LINE SOLENOID    ON
CONDENSER FAN STAGE     3
EEV OUTPUT              0.0%
SYSTEM                  XXX.X AMPS X.X VOLTS
    
```

DAILY SCHEDULE

```

S M T W T F S          *=HOLIDAY
MON START=00:00AM      STOP=00:00AM
TUE START=00:00AM      STOP=00:00AM
WED START=00:00AM      STOP=00:00AM
THU START=00:00AM      STOP=00:00AM
FRI START=00:00AM      STOP=00:00AM
SAT START=00:00AM      STOP=00:00AM
HOL START=00:00AM      STOP=00:00AM
    
```

2

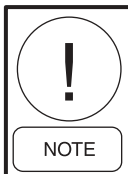

See Service And Troubleshooting section for Printer Installation information.

HISTORY PRINTOUT

Pressing the PRINT key and then the HISTORY key allows the operator to obtain a printout of information relating to the last 6 Safety Shutdowns which occurred. The information is stored at the instant of the fault, regardless of whether the fault caused a lockout to occur. The information is also not affected by power failures (long-term internal memory battery backup is built into the circuit board) or manual resetting of a fault lock-out.

When the HISTORY key is pressed, a printout is transmitted of all system operating conditions which were stored at the "instant the fault occurred" for each of the 6 Safety Shutdowns buffers. The printout will begin with the most recent fault which occurred. The most recent fault will always be stored as Safety Shutdown No. 1. Identically formatted fault information will then be printed for the remaining safety shutdowns.

Information contained in the Safety Shutdown buffers is very important when attempting to troubleshoot a system problem. This data reflects the system conditions at the instant the fault occurred and often reveals other system conditions which actually caused the safety threshold to be exceeded.

The history printout is similar to the operational data printout shown in the previous section. The differences are in the header and the schedule information. The daily schedule is not printed in a history print.

One example history buffer printout is shown following. The data part of the printout will be exactly the same as the operational data print so it is not repeated here. The difference is that the Daily Schedule is not printed in the history print and the header will be as follows.

```

YORK INTERNATIONAL CORPORATION
MILLENNIUM LIQUID CHILLER

SAFETY SHUTDOWN NUMBER 1
SHUTDOWN @ 3:56PM 29 JAN 02

SYS 1   HIGH DSCH PRESS SHUTDOWN
SYS 2                   NO FAULTS

```

HISTORY DISPLAYS

The HISTORY key gives the user access to many unit and system operating parameters at the time of a unit or system safety shutdown. When the HISTORY key is pressed the following message is displayed.

```

D I S P L A Y   S A F E T Y   S H U T -
D O W N   N O .   1   ( 1 T O 6 )

```

While this message is displayed, the UP arrow key can be used to select any of the six history buffers. Buffer number 1 is the most recent, and buffer number 6 is the oldest safety shutdown that was saved.

After selecting the shutdown number, pressing the ENTER key displays the following message which shows when the shutdown occurred.

```

S H U T D O W N   O C C U R R E D
0 3 : 5 6   P M   2 9   J A N   0 2

```

Pressing the DOWN arrow key repeatedly from the DISPLAY SAFETY SHUTDOWN NO. X displays the software version.

```

S O F T W A R E   V E R S I O N
C . M M C . 0 4 . 0 1

```

The UP and DOWN arrows are used to scroll forward and backward through the history buffer to display the shutdown conditions stored at the instant the fault occurred. The ↓ arrow key scrolls through the displays in the order they appear below:

```
UNIT FAULT :
LOW LIQUID TEMP
```

Displays the type of fault that occurred.

```
UNIT TYPE
LIQUID CHILLER
```

Displays the type of chiller; Liquid, Condensing Unit or Heat Pump.

```
CHILLED LIQUID
XXXXX
```

Displays the chilled liquid type; Water or Glycol.

```
AMBIENT CONTROL
XXXXXXXXXX
```

Displays the type of ambient control; Standard or Low Ambient. This message will not be displayed on YCAL0090 – YCAL0124.

```
LOCAL / REMOTE MODE
XXXXXXXXXX
```

Displays Local or Remote control selection.

```
CONTROL MODE
LEAVING LIQUID
```

Displays the type of chilled liquid control; Leaving or Return.

```
LEAD / LAG CONTROL
XXXXXXXXXX
```

Displays the type of lead/lag control; Manual System 1, Manual System 2 or Automatic. This is only selectable on 2-system chillers.

```
FAN CONTROL
DISCHARGE PRESSURE
```

Displays the type of fan control; Discharge Pressure or Ambient and Discharge Pressure. This message will not be displayed on YCAL0090 – YCAL0124.

```
MANUAL OVERRIDE MODE
XXXXXXXXXX
```

Displays whether manual override was Enabled or Disabled.

```
CURRENT FEEDBACK
XXXXXXXXXXXXXXXXXX
```

Displays type of Current Feedback utilized.

```
SOFT START
XXXXXX
```

Displays whether the optional European Soft Start was installed and selected.

```
DISCHARGE PRESSURE
CUTOUT = XXXX PSIG
```

Displays the programmed Discharge Pressure Cutout.

```
SUCTION PRESSURE
CUTOUT = XXXX PSIG
```

Displays the programmed Suction Pressure Cutout.

```
LOW AMBIENT TEMP
CUTOUT = XXX.X °F
```

Displays the programmed Low Ambient Cutout.

```
LEAVING LIQUID TEMP
CUTOUT = XXX.X °F
```

Displays the Leaving Liquid Temp. Cutout programmed.

```
FAN CONTROL ON
PRESSURE = XXX PSIG
```

Displays the programmed Fan On Pressure.

```
FAN DIFFERENTIAL OFF
PRESSURE = PSIG
```

Displays the programmed Fan Off Differential.

**SYS 1 TRIP VOLTS
= X . X VOLTS**

Displays the programmed High Current Trip Voltage.

**SYS 2 TRIP VOLTS
= X . X VOLTS**

Displays the programmed High Current Trip Voltage.

**LCHLT = XXX . X ° F
RCHLT = XXX . X ° F**

Displays the Leaving and Return chilled liquid temperature at the time of the fault.

**SETPOINT = XXX . X ° F
RANGE = + / - ° F**

Displays the programmed Setpoint and Range, if the chiller is programmed for leaving chilled liquid control.

**SETPOINT = XXX . X ° F
RANGE = + XX . X ° F**

Displays the programmed Setpoint and Range, if the chiller is programmed for return chilled liquid control.

**AMBIENT AIR TEMP
= XXX . X ° F**

Displays the Ambient Temp. at the time of the fault.

**LEAD SYSTEM IS
SYSTEM NUMBER X**

Displays which system is in the lead at the time of the fault.

**EVAP PUMP IS XXX
EVAP HEATER IS XXX**

Displays status of the evaporator pump and heater at the time of the fault.

**ACTIVE REMOTE CTRL
XXXX**

Displays whether Remote Chiller Control was active when the fault occurred.

**UNIT ACTUAL AMPS
= XXX . X AMPS**

This is only displayed when the Current Feedback Option is one per unit.

**SYS X COMP STATUS
1 = XXX 2 = XXX 3 = XXX**

Displays which compressors were running in the system when the fault occurred.

**SYS X RUN TIME
XX - XX - XX - XX D - H - M - S**

Displays the system run time when the fault occurred.

**SYS X SP = XXXX PSIG
DP = XXXX PSIG**

Displays the system Suction and Discharge Pressure of the time of the fault.

**SYS X SUCT = XXX . X ° F
SAT SUCT = XXX . X ° F**

Displays the System Suction Temp and Saturated Suction Temp when an EEV is installed.

**SYS X EEV = XXX . X %
SUCT SHEAT = XXX . X ° F**

Displays the EEV signal % and Suction Superheat when an EEV is installed.

**SYS X COOLER INLET
REFRIG TEMP = XXX . X ° F**

System Inlet cooler temperature will be displayed only on R-407c units.

**SYS X LLSV IS XXX
HOT GAS SOL IS XXX**

Displays whether the System Liquid Line Solenoid or Hot Gas Solenoid was energized at the time of the fault.

```
S Y S X F A N S T A G E X X X
```

Displays the number of fan stages in the system active at the time of the fault.

```
S Y S X A M P S = 4 0 . 3
      V O L T S = 2 . 2
```

Displays the system amperage (calculated approximately) and, DC feedback voltage from the 2ACE Module, at the time of the fault.

For this message to appear, CURRENT FEEDBACK ONE PER SYSTEM must be programmed under the options key. If the micro is programmed as one CURRENT FEEDBACK ONE PER UNIT under the program key, the display will be the first display prior to the SYS 1 info. If the micro is programmed for CURRENT FEEDBACK NONE, no current display will appear.

Displays for System 1 starting with SYS X NUMBER OF COMPS RUNNING X through SYS X AMPS = XXX.X VOLTS = X.X will be displayed first, followed by displays for System 2.

Further explanation of the above displays is covered under the STATUS, OPER DATA, COOLING SETPOINTS, PROGRAM, and OPTIONS keys.

“ENTRY” KEYS

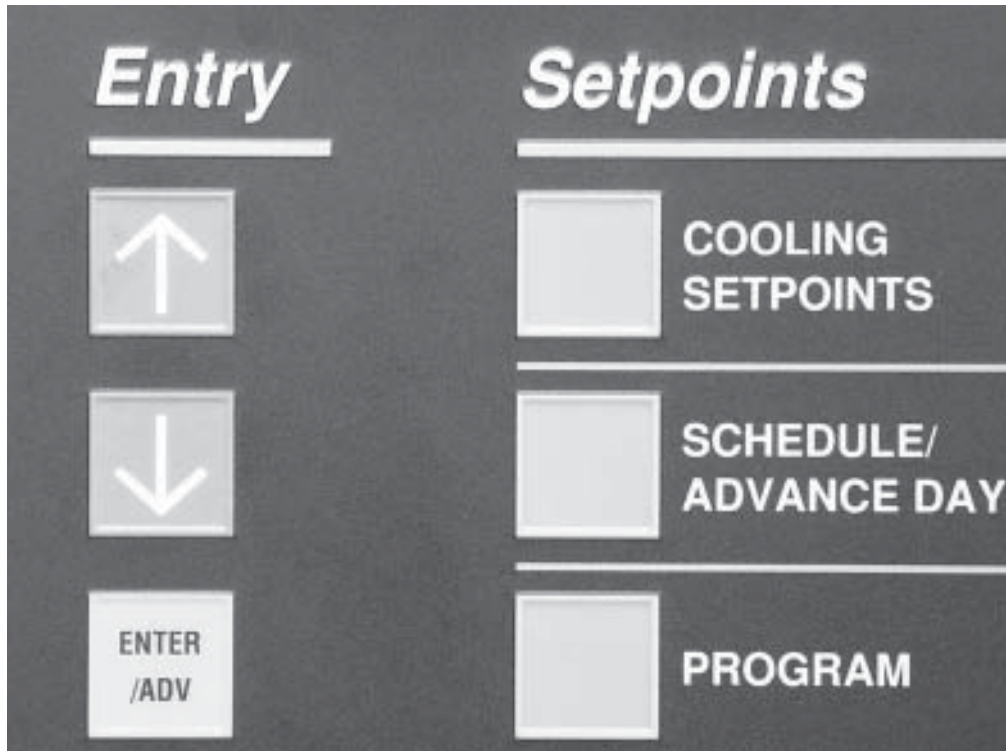

00068VIP

The Entry Keys allows the user to view, change programmed values. The ENTRY keys consist of an UP ARROW key, DOWN ARROW key, and an ENTER/ADV key.

UP AND DOWN ARROW KEYS

Used in conjunction with the OPER DATA, HISTORY, COOLING SETPOINTS, SCHEDULE/ADVANCE DAY, OPTIONS and CLOCK keys, the UP and DOWN arrow keys allow the user to scroll through the various data screens. Refer to the section on “DISPLAY/PRINT” keys for specific information on the displayed information and specific use of the UP and DOWN arrow keys.

The UP and DOWN arrow keys are also used for programming the control panel such as changing numeri-

cal or text values when programming cooling setpoints, setting the daily schedule, changing safety setpoints, chiller options, and setting the clock.

ENTER/ADV key

The ENTER key must be pushed after any change is made to the cooling setpoints, daily schedule, safety setpoints, chiller options, and the clock. Pressing this key “enters” the new values into memory. If the ENTER key is not pressed after a value is changed, the changes will not be “entered” and the original values will be used to control the chiller.

Programming and a description on the use of the UP and DOWN arrow and ENTER/ADV keys are covered in detail under the SETPOINTS, and UNIT keys.

“SETPOINTS” KEYS

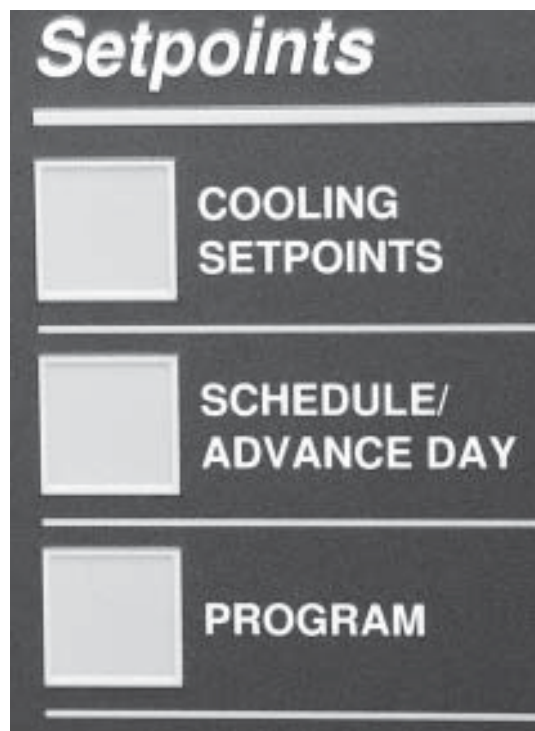

00069VIP

Programming of the cooling setpoints, daily schedule, and safeties is accomplished by using the keys located under the SETPOINTS section.

The three keys involved are labeled **COOLING SETPOINTS**, **SCHEDULE/ADVANCE DAY**, and **PROGRAM**.

Following are instructions for programming the respective setpoints. The same instruction should be used to view the setpoints with the exception that the setpoint will not be changed.

COOLING SETPOINTS

The Cooling Setpoint and Range can be programmed by pressing the COOLING SETPOINTS key.

LEAVING CHILLED LIQUID CONTROL

```

SETPOINT = 45.0 ° F
RANGE   = +/- 2.0 ° F
  
```

The above message shows the current chilled water temperature SETPOINT at 45.0°F (notice the cursor positioned under the number 0). Pressing either the UP or DOWN arrow will change the setpoint in .5°F increments. After using the UP and DOWN arrows to adjust to the desired setpoint, the ENTER/ADV key must be pressed to enter this number into memory and advance to the RANGE SETPOINT.

This will be indicated by the cursor moving under the current RANGE setpoint. The UP and DOWN arrow keys are used to set the RANGE, in .5 °F increments, to the desired RANGE setpoint. After adjusting the setpoint, the ENTER/ADV key must be pressed to enter the data into memory.

Notice that the RANGE was programmed for +/- X.X° F. This indicates the SETPOINT to be in the *center* of the control range. If the control mode has been programmed for RETURN LIQUID control, the message below would be displayed in place of the previous message.

When in leaving chilled liquid temperature control, the micro will attempt to control the leaving water temperature within the temperature range of the setpoint + or - the range. In the above example, control will be in the range of 43 - 47°F.

RETURN CHILLED LIQUID CONTROL

```

SETPOINT = 45.0 ° F
RANGE = + 2.0 ° F

```

Notice that the range no longer has a +/- X.X °F, but only a + X.X °F RANGE setpoint. This indicates that the setpoint is not centered within the RANGE but could be described as the bottom of the control range. A listing of the limits and the programmable values for the COOLING SETPOINTS are shown in Table 20.

The SETPOINT and RANGE displays just described were based on LOCAL control. If the unit was programmed for REMOTE control (under the OPTIONS key), the above programmed setpoints would have no effect.

When in return chilled liquid temperature control, the micro will turn all compressors off at setpoint and will turn compressors on as return chilled liquid temperature rises. All compressors will be on at setpoint + the range. If the range equals the temperature drop across the evaporator when fully loaded, the leaving chilled liquid temperature will remain near the setpoint + or - a few degrees as the chiller loads and unloads according to return chilled liquid temperature.

Both LEAVING and RETURN control are described in detail under the section on CAPACITY CONTROL.

Pressing the COOLING SETPOINTS key a second time will display the remote setpoint and cooling range. This display automatically updates about every 2 seconds. Notice that these setpoints are not "locally" programmable, but are controlled by a remote device such as an ISN control. These setpoints would only be valid if the unit was operating in the REMOTE mode.

The messages below illustrate both leaving chilled liquid control and return chilled liquid control respectively.

```

REM SETP = 44.0 ° F
RANGE = + / - 2.0 ° F

```

(leaving chilled liquid control)

```

REM SETP = 44.0 ° F
RANGE = +10.0 ° F

```

(return chilled liquid control)

The low limit, high limit, and default values for the keys under "SETPOINTS" are listed in Table 20.

Pressing the COOLING SETPOINTS a third time will bring up the display that allows the Maximum EMS-PWM Temperature Reset to be programmed. This message is shown below.

```

MAX EMS - PWM REMOTE
TEMP RESET = + 20 ° F

```

The Temp Reset value is the maximum allowable reset of the temperature setpoint. The setpoint can be reset upwards by the use of a contact closure on the PWM Temp Reset input (CTB1 terminals 13 - 20). See the section on Operating Controls for a detailed explanation of this feature.

As with the other setpoints, the Up Arrow and Down Arrow keys are used to change the Temp Reset value. After using the UP and DOWN ARROWS to adjust to the desired setpoint, the ENTER/ADV key must be pressed to enter this number into memory.

SCHEDULE/ADVANCE DAY key

The SCHEDULE is a seven day daily schedule that allows one start/stop time per day. The schedule can be programmed Monday through Sunday with an alternate holiday schedule available. If no start/stop times are programmed, the unit will run on demand, providing the chiller is not shut off on a unit or system shutdown. The daily schedule is considered "not programmed" when the times in the schedule are all zeros (00:00 AM).

To set the schedule, press the SCHEDULE/ADVANCE DAY key. The display will immediately show the following display.

```

MON START = 00:00 AM
STOP = 00:00 AM

```

The line under the 0 is the cursor. If the value is wrong, it may be changed by using the UP and DOWN arrow keys until correct. Pressing the ENTER/ADV key will

TABLE 20 – COOLING SETPOINTS, PROGRAMMABLE LIMITS AND DEFAULTS

SETPOINT KEY	MODE	LOW LIMIT	HIGH LIMIT	DEFAULT
LEAVING CHILLED LIQUID SETPOINT	WATER COOLING	40.0°F 4.4°C	**70.0°F 21.1°C	44.0°F 6.7°C
	GLYCOL COOLING	*10.0°F -12.2°C	**70.0°F 21.1°C	44.0°F 6.7°C
LEAVING CHILLED LIQUID CONTROL RANGE	—	1.5°F 0.8°C	2.5°F 1.4°C	2.0°F 1.1°C
RETURNED CHILLED LIQUID SETPOINT	WATER COOLING	40.0°F 4.4°C	70.0°F 21.1°C	44.0°F 6.7°C
	GLYCOL COOLING	10.0°F -12.2°C	70.0°F 21.1°C	44.0°F 6.7°C
RETURN CHILLED LIQUID CONTROL RANGE	—	4.0°F 2.2°C	20.0°F 11.1°C	10.0°F 5.6°C
MAX EMS-PWM REMOTE TEMPERATURE RESET	—	2°F 1.0°C	40°F 22.0°C	20°F 11.0°C

* Refer to Engineering Guide for operation below 30°F (-1.1°C). Alternate thermal expansion valves must be used below 30°F (-1.1°C).

* When using glycol, Leaving Chilled Liquid Setpoint should not be set below 20°F (-6.7°C).

** Do not exceed 55°F (12.8°C) setpoint before contacting the nearest YORK Office for application guidelines.

enter the times and then move the cursor to the minute box. The operation is then repeated if necessary. This process may be followed until the hour, minutes, and meridian (AM or PM) of both the START and STOP points are set. After changing the meridian of the stop time, pressing the ENTER/ADV key will advance the schedule to the next day.

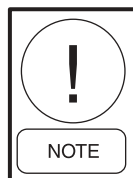

Whenever the daily schedule is changed for Monday, all the other days will change to the new Monday schedule. This means if the Monday times are not applicable for the whole week then the exceptional days would need to be reprogrammed to the desired schedule.

To page to a specific day press the SCHEDULE/ADVANCE DAY key. The start and stop time of each day may be programmed differently using the UP and DOWN arrow, and ENTER/ADV keys.

After SUN (Sunday) schedule appears on the display a subsequent press of the SCHEDULE/ADVANCE DAY key will display the Holiday schedule. This is a two part display. The first reads:

```
H O L   S T A R T   =   0 0 : 0 0   A M
                S T O P   =   0 0 : 0 0   A M
```

The times may be set using the same procedure as described above for the days of the week. After changing the meridian of the stop time, pressing the ENTER/ADV key will advance the schedule to the following display:

```
S _ M T W T F S
H O L I D A Y   N O T E D   B Y   *
```

The line below the empty space next to the S is the cursor and will move to the next empty space when the ENTER/ADV key is pressed. To set the Holiday, the cursor is moved to the space following the day of the week of the holiday and the UP arrow key is pressed. An * will appear in the space signifying that day as a holiday. The * can be removed by pressing the DOWN arrow key.

The Holiday schedule must be programmed weekly – once the Holiday schedule runs, it will revert to the normal daily schedule.

PROGRAM key

There are several operating parameters under the PROGRAM key that are programmable. These setpoints can be changed by pressing the PROGRAM key, and then the ENTER/ADV key to enter *Program Mode*. Continuing to press the ENTER/ADV key will display each operating parameter. While a particular parameter is being displayed, the UP and DOWN arrow keys can be

used to change the value. After the value is changed, the ENTER/ADV key must be pressed to enter the data into memory. Table 27 shows the programmable limits and default values for each operating parameter.

Following are the displays for the programmable values in the order they appear:

DISCHARGE PRESSURE
CUTOUT = 395 PSIG

DISCHARGE PRESSURE CUTOUT is the discharge pressure at which the system will shutdown as monitored by the *optional* discharge transducer. This is a software shutdown that acts as a backup for the mechanical high pressure switch located in the refrigerant circuit. The system can restart when the discharge pressure drops 40 PSIG (2.76 BARG) below the cutout point.

If the optional discharge pressure transducer is not installed, this programmable safety would not apply. It should be noted that every system has a *mechanical* high pressure cutout that protects against excessive high discharge pressure regardless of whether or not the optional discharge pressure is installed.

SUCTION PRESSURE
CUTOUT = 44.0 PSIG

The SUCTION PRESSURE CUTOUT protects the chiller from an evaporator freeze-up. If the suction pressure drops below the cutout point, the system will shut down.

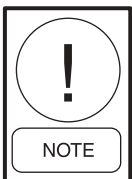

There are some exceptions when the suction pressure is permitted to temporarily drop below the cutout point. Details are explained under the topic of SYSTEM SAFETIES.

LOW AMBIENT TEMP
CUTOUT = 25.0 °F

The LOW AMBIENT TEMP CUTOUT allows the user to select the chiller outside ambient temperature cutout point. If the ambient falls below this point, the chiller will shut down. Restart can occur when temperature rises 2°F (1.11°C) above the cutout setpoint.

LEAVING LIQUID TEMP
CUTOUT = 36.0 °F

The LEAVING LIQUID TEMP CUTOUT protects the chiller from an evaporator freeze-up. Anytime the leaving chilled liquid temperature drops to the cutout point, the chiller shuts down. Restart will be permitted when the leaving chilled liquid temperature rises 2°F (1.11°C) above the cutout setpoint.

When water cooling mode is programmed (OPTIONS key), the value is fixed at 36.0°F (2.22°C) and cannot be changed. Glycol cooling mode can be programmed to values listed in Table 20.

ANTI RECYCLE TIMER
= 600 SEC

The programmable anti-recycle timer assures that systems do not cycle. This timer is programmable under the PROGRAM key between 300 - 600 seconds. Whenever possible, to reduce cycling and motor heating, the anti-recycle timer should be adjusted as high as possible. The programmable anti-recycle timer starts the timer when the first compressor in a system starts. The timer begins to count down. If all the compressors in the circuit cycle off, a compressor within the circuit will not be permitted to start until the anti-recycle timer has timed out. If the lead system has run for less than 5 minutes, 3 times in a row, the anti-recycle timer will be extended to 10 minutes maximum.

FAN CONTROL ON
PRESSURE = XXX PSIG

The Fan Control On-Pressure is the programmed pressure value that is used to stage the condenser fans on, in relation to discharge pressure. Refer to Condenser Fan Control in the UNIT OPERATION section and Tables 27 - 33.

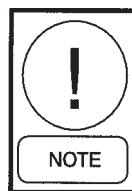

The microprocessor will not allow programming the “FAN CONTROL ON PRESSURE” minus the “FAN CONTROL DIFFERENTIAL OFF PRESSURE” below 160PSIG. This assures discharge pressure does not drop too low.

FAN DIFFERENTIAL OFF
PRESSURE = XXX PSIG

The Fan Differential Off Pressure is the programmed differential pressure value that is used to stage the condenser fans off, in relation to discharge pressure. Refer to Condenser Fan Control in the UNIT OPERATION section and Tables 27 - 33.



The microprocessor will not allow programming the “FAN CONTROL ON PRESSURE” minus the “FAN CONTROL DIFFERENTIAL OFF PRESSURE” below 160 PSIG. This assures discharge pressure does not drop too low.

**TOTAL NUMBER OF
COMPRESSORS = 6**

The TOTAL NUMBER OF COMPRESSORS is the total quantity of compressors in the chiller, and determines the stages of cooling available. Note in Table 21, the chiller may have single or dual systems.

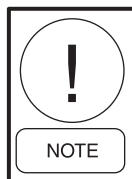

This MUST be programmed correctly to assure proper chiller operation.

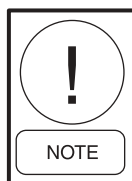

A single system chiller MUST have a jumper between terminals 13 - 17 on terminal block CTB1. If the jumper is not installed, the unit will act as a 2-system chiller. The jumper is only checked by the micro at unit power-up. If the jumper is removed, power must be removed and re-applied to register the change in memory.

**NUMBER OF FANS
PER SYSTEM = X**

The number of fans per system is programmed for the total number of fans on each system, or the total number on the chiller divided by 2. This is only programmable on YCAL0090 - YCAL0124 chillers.

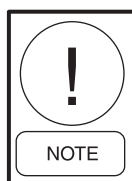

This MUST be programmed correctly to assure proper chiller operation.

**SYS X TRIP VOLTS
= X.X VOLTS**

**UNIT TRIP VOLTS
= X.X VOLTS**

Depending on the option, the trip voltage for a specific system or unit high current trip (See page 86) can be programmed. It also calibrates the current read-out under the OPER DATA key. The approximate programmed value is calculated using the following formulas:

460VAC SYSTEM TRIP VOLTS

For individual system high current trip programming on 460VAC chillers:

- Add the sum of the compressor and fan RLA's in the system
- Multiply the sum by 1.25
- Divide by 225A
- The resulting voltage is the value that should be programmed

For example, if fan and compressor RLA's total 100A:

$$\frac{5V \times 100A}{225A} \times 1.25 = \frac{625VA}{225A} = 2.8V$$

The programmed value will be 2.8V. A similar calculation and programming will be necessary for the other system in a 2-system chiller.

460VAC UNIT TRIP VOLTS

For total chiller high current trip programming on 460VAC chillers:

- Add the sum of all the the compressor and fan RLA's in the chiller
- Multiply the sum by 1.25
- Divide by 225A
- The resulting voltage is the value that should be programmed

For example, if fan and compressor RLA's total 180A:

$$\frac{5V \times 180A}{225A} \times 1.25 = \frac{1125VA}{225A} = 5.0V$$

The programmed value will be 5.0V.

208/230VAC CHILLERS

On 208/230VAC chillers, the process is similar, but instead of performing the calculation using 225A, a number of 450A must be substituted.

**REMOTE UNIT ID
PROGRAMMED = X**

When communications is required with a BAS or OptiView Panel, individual unit IDs are necessary for communications with specific chillers on a single RS-485 line. ID 0-7 is selectable.

**SYS 1 SUCT SUPERHEAT
SETPOINT = XX.X °F**

**SYS 2 SUCT SUPERHEAT
SETPOINT = XX.X °F**

These messages only appear and are programmable when EEV is selected as the expansion valve type in the Service Mode. EEV must only be selected when an EEV is installed. Superheat is programmable between 10°F - 15°F. A setpoint of 12°F - 15°F is recommended.

TABLE 21 – PROGRAM KEY LIMITS AND DEFAULTS

PROGRAM VALUE	MODE	LOW LIMIT	HIGH LIMIT	DEFAULT
DISCHARGE PRESSURE CUTOUT	—	200 PSIG	399 PSIG	395 PSIG
		13.8 BARG	27.5 BARG	27.2 BARG
SUCTION PRESSURE CUTOUT	WATER COOLING	44.0 PSIG	70.0 PSIG	44.0 PSIG
		3.03 BARG	4.83 BARG	3.03 BARG
	GLYCOL COOLING	20.0 PSIG	70.0 PSIG	44.0 PSIG
		1.38 BARG	4.83 BARG	3.03 BARG
LOW AMBIENT TEMP. CUTOUT	STANDARD AMBIENT	25.0°F	60.0°F	25.0°F
		-3.9°C	15.6°C	-3.9°C
	LOW AMBIENT	0°F	60.0°F	25.0°F
		-17.8°C	15.6°C	-3.9°C
LEAVING CHILLED LIQUID TEMP. CUTOUT	WATER COOLING	—	—	36°F
		—	—	2.2°C
	GLYCOL COOLING	8.0°F	36.0°F	36.0°F
		-13.3°C	2.2°C	2.2°C
ANTI-RECYCLE TIMER	—	300 SEC.	600 SEC.	600 SEC.
FAN CONTROL ON PRESSURE	—	225 PSIG	260 PSIG	240 PSIG
		15.5 BARG	17.9 BARG	16.5 BARG
FAN DIFFERENTIAL OFF PRESSURE	—	50 PSIG	100 PSID*	80 PSID
		3.45 BARG	6.89 BARG*	5.52 BARG
TOTAL NUMBER OF COMPRESSORS	SINGLE SYSTEM	2	3	3
	TWO SYSTEMS	4	6	6
NUMBER OF FANS PER SYSTEM	YCAL0090 – YCAL0124 ONLY	3	4	3
UNIT/SYSTEM TRIP VOLTS	CURRENT FEEDBACK OPTION ENABLED ONE PER UNIT	0.5	4.5	2
REMOTE UNIT ID	—	0	7	0
SYSTEM 1 SUPERHEAT SETPOINT	EEV	10.0°F	15.0°F	12.0°F
		5.5°C	8.3°C	6.6°C
SYSTEM 2 SUPERHEAT SETPOINT	EEV	10.0°F	15.0°F	12.0°F
		5.5°C	8.3°C	6.6°C

* The minimum discharge pressure allowed is 160 PSIG. The fan differential Off Pressure will be lowered to prevent going below 160 PSIG based on where the fan control On Pressure is programmed.

Table 22 provides a quick reference of the setpoints list for the Setpoints Keys.

TABLE 22 – SETPOINTS QUICK REFERENCE LIST

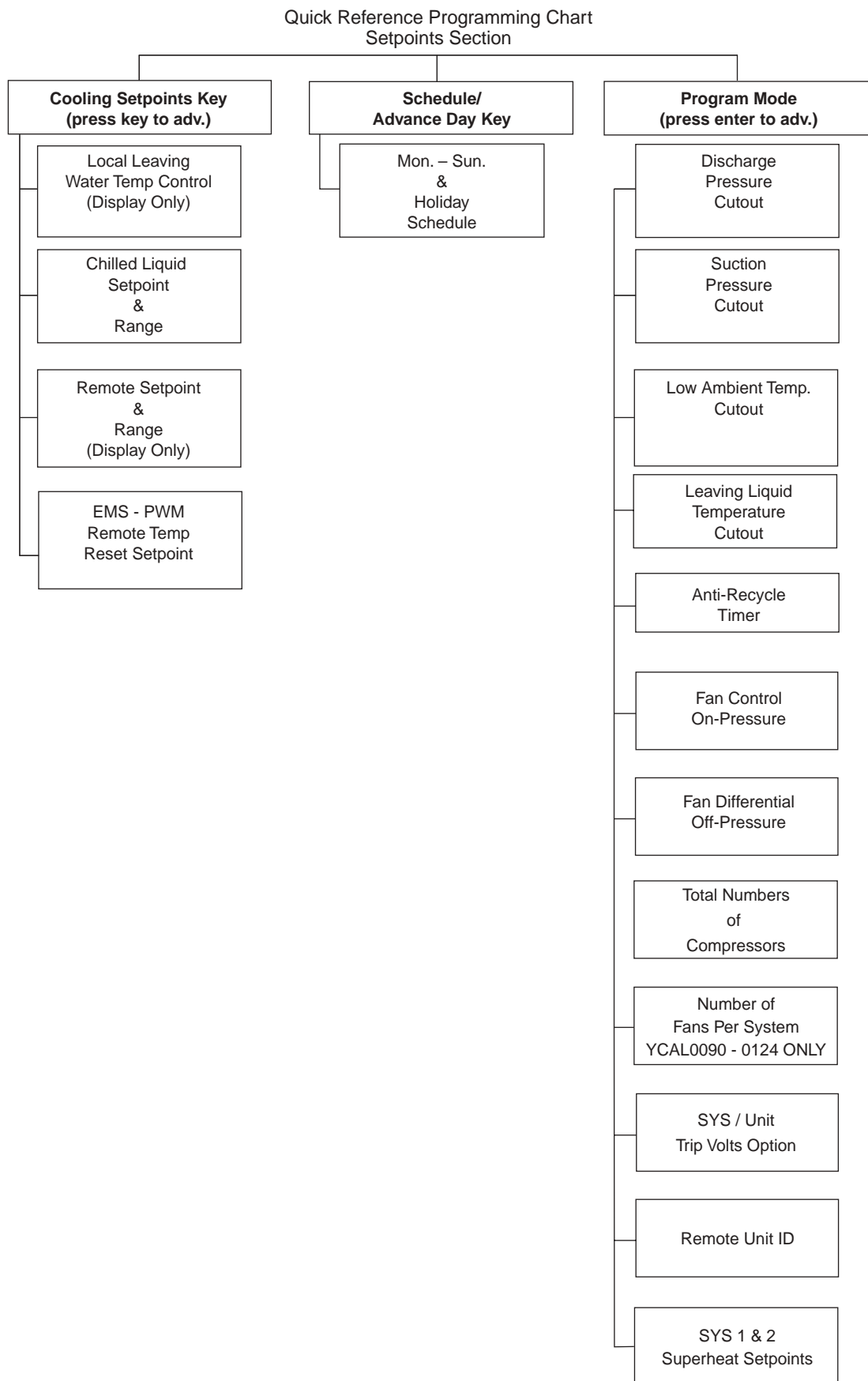

2

“UNIT” KEYS



00070VIP

OPTIONS key

There are many programmable options under the OPTIONS key. The OPTIONS key is used to scroll through the list of options by repeatedly pressing the OPTIONS key. After the selected option has been displayed, the UP and DOWN arrow keys are then used to change that particular option. After the option is changed, the ENTER/ADV key must be pressed to enter the data into memory. Table 23 shows the programmable options. Following are the displays in the order they appear:

Option 1 – Language:

DISPLAY LANGUAGE
ENGLISH

English, Spanish, French, German, and Italian can be programmed.

Option 2 – System Switches: (two system units only) (Single System Display is similar)

SYS 1 SWITCH ON
SYS 2 SWITCH ON

This allows both systems to run
or

SYS 1 SWITCH ON
SYS 2 SWITCH OFF

This turns system 2 off
or

SYS 1 SWITCH OFF
SYS 2 SWITCH ON

This turns system 1 off
or

SYS 1 SWITCH OFF
SYS 2 SWITCH OFF

This turns systems 1 & 2 off

Note: Turning a system off with its system switch allows a pumpdown to be performed prior to shutdown.

Option 3 – Chilled Liquid Cooling Type:

CHILLED LIQUID
WATER

The chilled liquid is water. The Cooling Setpoint can be programmed from 40°F to 70°F (4.4°C to 21.1°C)
or

CHILLED LIQUID
GLYCOL

The chilled liquid is glycol. The Cooling Setpoint can be programmed from 10°F to 70°F (-12.2°C to 21.1°C).

**Option 4 – Ambient Control Type:
(YCAL00014-00080 Only)**

A M B I E N T C O N T R O L
S T A N D A R D

The low ambient cutout is adjustable from 25°F to 60°F (-3.9°C to 15.6°C).

or

A M B I E N T C O N T R O L
L O W A M B I E N T

The low ambient cutout is programmable down to 0°F (-17.8°C). **A low ambient kit MUST be installed for this option to be chosen. If the kit is NOT installed, and low ambient is selected, low pressure faults and compressor damage may occur. YCAL0090-0124 are fixed in the low ambient mode as standard and cannot be reprogrammed.**

Option 5 – Local/Remote Control Type:

L O C A L / R E M O T E M O D E L
L O C A L

When programmed for LOCAL, an ISN or RCC control can be used to monitor only. The micro panel will operate on locally programmed values and ignore all commands from the remote devices. The chiller will communicate and send data to the remote monitoring devices.

or

L O C A L / R E M O T E M O D E
R E M O T E

This mode should be selected when an ISN or RCC control is to be used to control the chiller. This mode will allow the ISN to control the following items: Remote Start/Stop, Cooling Setpoint, Load Limit, and History Buffer Request. If the unit receives no valid ISN transmission for 5 minutes, it will revert back to the locally programmed values.

Option 6 – Unit Control Mode:

C O N T R O L M O D E
R E T U R N L I Q U I D

Unit control is based on return chilled liquid temp. Return Chilled Liquid Control can only be selected on units that have 4 to 6 compressors (dual system units).

or

C O N T R O L M O D E
L E A V I N G L I Q U I D

Unit control is based on leaving chilled liquid temp.

Refer to section on Capacity Control for details on loading and unloading sequences.

Option 7 – Display Units:

D I S P L A Y U N I T S
I M P E R I A L

This mode displays system operating values in Imperial units of °F or PSIG.

or

D I S P L A Y U N I T S
S I

This mode displays system operating values in Scientific International Units of °C or BARG.

Option 8 – Lead/Lag Type (two system units only):

L E A D / L A G C O N T R O L
M A N U A L S Y S 1 L E A D

SYS 1 selected as lead compressor. SYS 1 lead option MUST be chosen if Hot Gas Bypass is installed.

or

L E A D / L A G C O N T R O L
M A N U A L S Y S 2 L E A D

SYS 2 selected as lead compressor.

or

L E A D / L A G C O N T R O L
A U T O M A T I C

Lead/lag between systems may be selected to help equalize average run hours between systems on chillers with 2 refrigerant systems. Auto lead/lag allows automatic lead/lag of the two systems based on an average run hours of the compressors in each system. A new lead/lag assignment is made whenever all compressors shut down. The micro will then assign the “lead” to the system with the shortest average run time.

**Option 9 – Condenser Fan Control Mode
(YCAL0014-0080 Only):**

F A N C O N T R O L
D I S C H A R G E P R E S S U R E

Condenser fans are controlled by discharge pressure only. This mode may only be chosen when discharge pressure transducers are installed. YCAL0090-0124 are fixed in the fan control by discharge pressure mode and cannot be reprogrammed.

or

FAN CONTROL
AMBIENT & DSCH PRESS

Condenser fans are controlled by ambient temperature and discharge pressure. This mode must be chosen if the discharge pressure transducers are **not** installed.

Option 10 – Manual Override Mode:

MANUAL OVERRIDE MODE
DISABLED

This option allows overriding of the daily schedule that is programmed. MANUAL OVERRIDE MODE – DISABLED indicates that override mode has no effect.

or

MANUAL OVERRIDE MODE
ENABLED

Manual Override Mode is enabled. This is a service function and when enabled, will allow the unit to start when shut down on the daily schedule. It will automatically be disabled after 30 minutes.

Option 11 – Current Feedback Options Installed:

CURRENT FEEDBACK
NONE

This mode should be selected when the panel is not equipped with current sensing capability.

or

CURRENT FEEDBACK
ONE PER UNIT

This mode should be selected when an optional 2ACE Module is installed to allow combined current monitoring of all systems by sensing current on the incoming line. Current input is to J8-5 of the micro.

or

CURRENT FEEDBACK
ONE PER SYSTEM

This mode should be selected when an optional 2ACE module is installed to allow individual current monitoring of each system. SYS 1 input is to J8-5 of the micro. SYS 2 input is to J8-6 of the micro.

Option 12 – Soft Start Enable/Disable:

SOFT START
ENABLED

This should only be enabled on European units with soft start on 2 compressors. This feature modifies the compressor lead/lag to start the compressor(s) furthest from the control panel last to minimize current inrush. These compressors will be equipped with a soft starter.

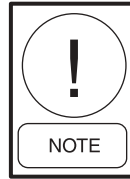

Soft start is only viewable under OPTIONS key and must be programmed from the Service Mode.

On 2 compressor chillers, soft start will always be applied to the compressor furthest from the control panel. This compressor will always start last to minimize current inrush with the other compressor running.

On 4 compressor chillers, soft start will always be applied to the compressor furthest from the control panel on each system. These compressors will always start last to minimize current inrush with the other compressors running.

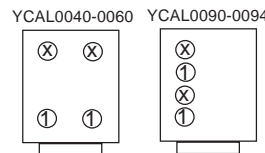

x = Compressors with soft start

Control Panel End

On 5 compressor chillers, soft start will always be applied to the compressor furthest from the control panel on each system. Compressors 1 and 2 will continue to lead/lag per the selected option. The soft start compressors will always start last, to minimize current inrush with the other compressors running.

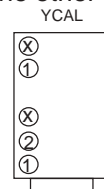

x = Compressors with soft start

Control Panel End

On 6 compressor chillers, soft start will always be applied to the compressors furthest from the control panel on each system. Compressors 1 and 2 of each system will continue to lead/lag per the selected option. The soft start compressors will always start last to minimize current inrush with the other compressors running.

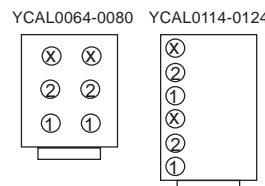

x = Compressors with soft start

Control Panel End

**S O F T S T A R T
D I S A B L E D**

This **MUST** be selected on all chillers without the soft start option.

Option 13 – Unit Type:

**U N I T T Y P E
L I Q U I D C H I L L E R**

The UNIT TYPE message cannot be modified under the unit keys.



“LIQUID CHILLER” must be displayed, or damage to compressors or other components will occur if operated in the HEAT PUMP or CONDENSING UNIT modes.

If unit type needs to be changed to make the unit a liquid chiller, remove the jumper between J4-6 and J4-11 and reapply power to the micropanel.

Option 14 – Refrigerant Type:

**R E F R I G E R A N T T Y P E
R - 2 2**

Refrigerant type R-22 or R-407C may be selected under Service Mode. Refrigerant type is displayed under the Options Key, but is only programmable in Service Mode.



Incorrect programming may cause damage to compressors.

Option 15 – Expansion Valve Type:

**E X P A N S I O N V A L V E T Y P E
T H E R M O S T A T I C**

Expansion valve type, thermostatic or electronic may be selected under Service Mode. Expansion valve type is displayed under the Options key, but is only programmable in Service Mode.



Incorrect programming may cause damage to compressors.

Also see the UNIT KEYS PROGRAMMING QUICK REFERENCE LIST in Table 23, Page 100.

CLOCK

The CLOCK display shows the current day, time, and date. Pressing the CLOCK key will show the current day, time, and date.

It is important that the date and time be correct, otherwise the daily schedule will not function as desired if programmed. In addition, for ease of troubleshooting via the History print-outs, the day, time, and date should be correct.

To change the day, time, and date press the CLOCK key. The display will show something similar to the following:

T O D A Y I S E R I 0 8 : 5 1 A M
2 5 J A N 0 2

The line under the E is the cursor. If the day is correct, press the ENTER/ADV key. The cursor will move under the 0 in 08 hours. If the day is incorrect, press the UP or DOWN arrow keys until the desired day is displayed and then press the ENTER/ADV key at which time the day will be accepted and the cursor will move under the first digit of the “2 digit hour”. In a similar manner, the hour, minute, meridian, month, day, and year may be programmed, whenever the cursor is under the first letter/numeral of the item. Press the UP or DOWN arrow keys until the desired hour, minute, meridian, day, month, and year are displayed. Pressing the ENTER/ADV Key will save the value and move the cursor on to the next programmable variable.

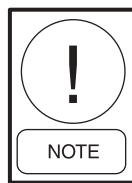

Jumper J11 on the microboard must be set to the “CLKON” position to turn on the clock. If this is not done, the clock will not function.

Table 23 provides a quick reference list for the Unit key setpoints.

TABLE 23 – UNIT KEYS PROGRAMMING QUICK REFERENCE LIST

**Quick Reference Programming Chart
Unit Keys Section**

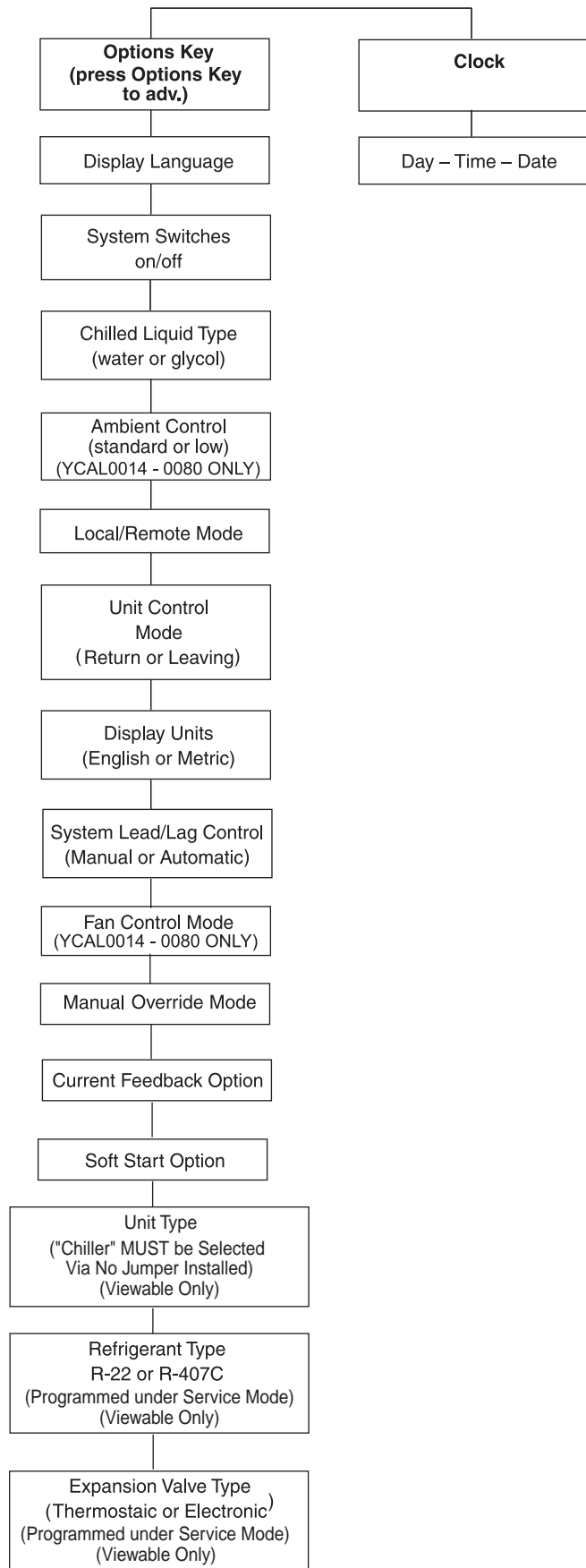

UNIT OPERATION

CAPACITY CONTROL

To initiate the start sequence of the chiller, all run permissive inputs must be satisfied (flow/remote start/stop switch), and no chiller or system faults exist.

The first phase of the start sequence is initiated by the Daily Schedule Start or a Remote Cycling Device. If the unit is shut down on the daily schedule, the chilled water pump microboard contacts (TB5 3-4) will close when the daily schedule start time has been reached. Once flow has been established and the flow switch closes, capacity control functions are initiated.

If unit cycling is accomplished with a remote cycling device wired in series with the flow switch, the chilled water pump contacts will always be energized as long as the unit switch is turned on. When the flow switch and remote cycling contacts are closed, the capacity control functions will be initiated.

It should be noted that the chilled water pump contacts (TB5 3-4) are not required to be used to cycle the chilled water pump. However, in all cases the flow switch must be closed to allow unit operation.

The control system will evaluate the need for cooling by comparing the actual leaving or return chilled liquid temperature to the desired setpoint, and regulate the leaving or return chilled liquid temperature to meet that desired setpoint.

SUCTION PRESSURE LIMIT CONTROLS

The anticipatory controls are intended to prevent the unit from ever actually reaching a low-pressure cutout. Loading is prevented, if the suction pressure drops below 1.15 x suction pressure cutout. Load may reoccur after suction pressure rises above the unload point and a period of one minute elapses. This control is only operable if the optional suction pressure transducers are installed.

DISCHARGE PRESSURE LIMIT CONTROLS

The discharge pressure limit controls unload a system before it reaches a safety limit due to high load or dirty condenser coils. The micro monitors discharge pressure and unloads a system, if fully loaded, by one compressor when discharge pressure exceeds the programmed cutout minus 15 PSIG. Reloading will occur when the discharge pressure on the affected system drops to 85% of the unload pressure and 10 minutes have elapsed.

This control is only applicable if optional discharge pressure transducers are installed.

LEAVING CHILLED LIQUID CONTROL

The setpoint, when programmed for Leaving Chilled Liquid Control, is the temperature the unit will control to within +/- the cooling range. The Setpoint High Limit is the Setpoint plus the Cooling Range. The Setpoint Low Limit is the Setpoint minus the Cooling Range. See Figure 8. Figure 8 should be utilized to aid in understanding the remainder of the description of Leaving Chilled Liquid Control.

If the leaving chilled liquid temperature is above the Setpoint High Limit, the lead compressor on the lead system will be energized along with the liquid line solenoid. Upon energizing any compressor, the 60 second Anti-Coincidence timer will be initiated.

If after 60 seconds of run-time the leaving chilled liquid temperature is still above the Setpoint High Limit, the next compressor in sequence will be energized. Additional compressors will be energized at a rate of once every 60 seconds if the chilled liquid temperature remains above the Setpoint High Limit and the chilled liquid temperature is dropping less than 3°F/min. The lag system will not be allowed to start a compressor until the lead system has run for 5 minutes.

If the chilled liquid temperature falls below the Setpoint High Limit but is greater than the Setpoint Low Limit, loading and unloading do not occur. This area of control is called the control range.

If the chilled liquid temperature drops to between Setpoint Low Limit and 0.5°F (.28°C) below the Setpoint Low Limit, unloading occurs at a rate of 60 seconds. If the chilled liquid temperature falls to a value greater than 0.5°F (.28°C) below the Setpoint Low Limit but not greater than 1.5°F (.83°C) below the Setpoint Low Limit, unloading occurs at a rate of 20 seconds. If the chilled liquid temperature falls to a value greater than 1.5°F (.83°C) below the Setpoint Low Limit, unloading occurs at a rate of 30 seconds. If the chilled liquid temperature falls below 1°F above the low chilled liquid temperature cutout, unloading occurs at a rate of 10 seconds.

Hot gas, if present, will be the final step of capacity. If temperature remains below the setpoint low limit on the lowest step of capacity, the micro will close the liquid line solenoid or EEV, after turning off hot gas, and pump the system down before turning off the last compressor in a system.

The leaving chilled liquid setpoint is programmable from 40°F to 70°F (4.4°C to 21.1°C) in water chilling mode and from 10°F to 70°F (-12.2°C to 21.1°C) in glycol chilling mode. In both modes, the cooling range can be from +/-1.5°F to +/-2.5°F (+/- .83°C to 1.39°C).

LEAVING CHILLED LIQUID CONTROL OVERRIDE TO REDUCE CYCLING

To avoid compressor cycling the micro will adjust the setpoint upward temporarily. The last run time of the system will be saved. If the last run time was greater than 5 minutes, no action is to be taken. If the last run time for the lead system was less than 5 minutes, increase the setpoint high limit according to the chart at right, with a maximum value allowed of 50°F.

If adding the setpoint adjust value to the setpoint high limit causes the setpoint high limit to be greater than 50°F, the setpoint high limit will be set to 50°F, and the difference will be added to the setpoint low limit.

Once a system runs for greater than 5 minutes, the setpoint adjust will be set back to 0. This will occur while the system is still running.

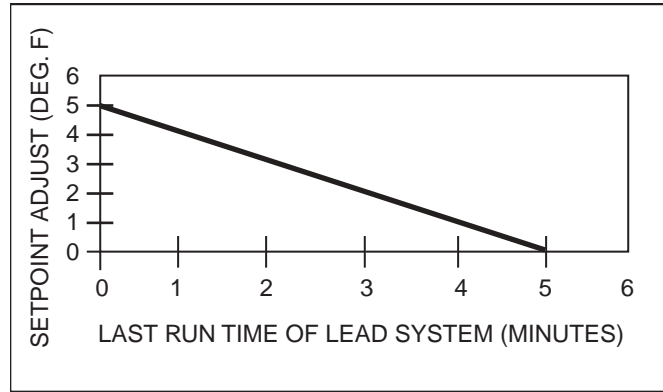
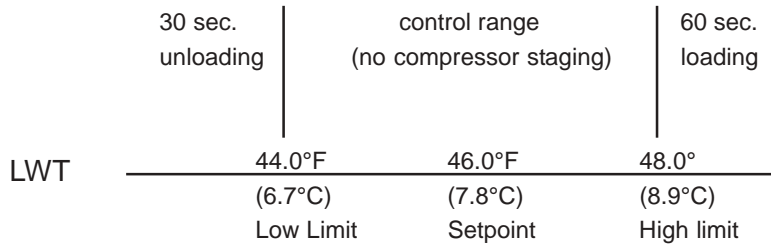

FIG. 7 – SETPOINT ADJUST



Leaving Water Temp. Control – Compressor Staging
 Setpoint = 46.0°F (7.8°C) Range = +/- 2°F(1.1°C)

FIG. 8 – LEAVING WATER TEMPERATURE CONTROL EXAMPLE

RETURN CHILLED LIQUID CONTROL (Can be used on Dual System 4, 5 & 6 Comp Units Only)

Return chilled liquid control is based on staging the compressors to match the cooling load. The chiller will be fully loaded when the return water temperature is equal to the Cooling Setpoint plus the Range. The chiller will be totally unloaded (all compressors off) when the return water temperature is equal to the Cooling Setpoint. (See sample in Table 24) At return water temperatures between the Cooling, and Cooling Setpoint plus Range, compressor loading and unloading will be determined by the formulas in Table 25 or Table 26.



Return Chilled Liquid Control MUST only be used when constant chilled liquid flow is ensured.

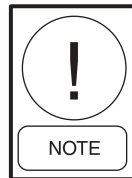

The RANGE MUST always be programmed to equal the temperature drop across the evaporator when the chiller is “fully loaded”. Otherwise, chilled liquid temperature will over or under shoot.

Normal loading will occur at intervals of 60 seconds according to the temperatures determined by the formulas. Unloading will occur at a rate of 30 seconds according to the temperatures determined in the formulas.

The return chilled liquid setpoint is programmable from 40°F to 70°F (4.4°C to 21.1°C) in water chilling mode and from 10°F to 70°F (-12.2°C to 21.1°C) in glycol chilling mode. In both modes, the cooling range can be from 4°F to 20°F (2.2° to 11.1°C).

As an example of compressor staging (refer to Table 34), a chiller with six compressors using a Cooling Setpoint programmed for 45°F (7.20°C) and a Range Setpoint of 10°F (5.56°C). Using the formulas in Table 25, the control range will be split up into six (seven including hot gas) segments, with the Control Range determining the separation between segments. Note also that the Cooling Setpoint is the point at which all compressors are off, and Cooling Setpoint plus Range is the point all compressors are on. Specifically, if the return water temperature is 55°F (12.8°C), then all compressors will be on, providing full capacity. At nominal gpm, this would provide approximately 45°F (7.2°C) leaving water temperature out of the evaporator.

If the return water temperature drops to 53.4°F (11.9°C), one compressor would cycle off leaving five compressors running. The compressors would continue to cycle off approximately every 1.7°F (.94°C), with the excep-

tion of hot gas bypass. Notice that the hot gas bypass would be available when the return water temperature dropped to 46.25°F (7.9°C). At this point one compressor would be running.

Should the return water temperature rise from this point to 46.7°F (8.2°C), the hot gas bypass would shut off, still leaving one compressor running. As the load increased, the compressors would stage on every 1.7°F (.94°C).

Also notice that Tables 24, 25 and 26 not only provide the formulas for the loading (ON POINT) and unloading (OFF POINT) of the system, the "STEP" is also shown in the tables. The "STEP" is that sequence in the capacity control scheme that can be viewed under the OPER DATA key. Please refer to the section on the DISPLAY/PRINT keys for specific information on the OPER DATA key.

2

TABLE 24 – COMPRESSOR STAGING FOR RETURN WATER CONTROL

COMPRESSOR STAGING FOR RETURN WATER CONTROL								
6 COMPRESSORS								
COOLING SETPOINT = 45°F (7.2°C) RANGE = 10°F (5.6°C)								
# OF COMP ON	0	*1+HG	1	2	3	4	5	6
RWT	45°F (7.2°C)	46.25°F (7.9°C)	46.7°F (8.2°C)	48.3°F (9.1°C)	50.0°F (10.0°C)	51.7°F (11.0°C)	53.4°F (11.9°C)	55.0°F (12.8°C)

*Unloading only

TABLE 25 – RETURN CHILLED LIQUID CONTROL FOR 5 & 6 COMPRESSORS (7 & 8 STEPS)

*STEP	COMPRESSOR	COMPRESSOR ON POINT	COMPRESSOR OFF POINT
0	0	SETPOINT	SETPOINT
1	1 W/HGB	SP + CR/8 (Note 1)	SETPOINT
2	1 NO HGB	SP + CR/6	SETPOINT
3	2	SP + 2*CR/6 (Note 2)	SP + CR/6
4	2	SP + 2*CR/6	SP + CR/6 (Note 3)
5	3	SP + 3*CR/6	SP + 2*CR/6
6	4	SP + 4*CR/6	SP + 3*CR/6
7**	5	SP + 5*CR/6	SP + 4*CR/6
8	6	SP + CR	SP + 5*CR/6

* STEP can be viewed using the OPER DATA key and scrolling to COOLING DEMAND.

** 5-Compressor Chillers stop at 7 steps

NOTES:

- Step 1 is Hot Gas Bypass and is skipped when loading occurs. Hot Gas Bypass operation is inhibited during Pumpdown.
- Step 3 is skipped when loading occurs.
- Step 4 is skipped when unloading occurs.

TABLE 26 – RETURN CHILLED LIQUID CONTROL FOR 4 COMPRESSORS (6 STEPS)

*STEP	COMPRESSOR	COMPRESSOR ON POINT	COMPRESSOR OFF POINT
0	0	SETPOINT	SETPOINT
1	1 W/HGB	SP + CR/8 (Note 1)	SETPOINT
2	1 NO HGB	SP + CR/4	SP + CR/8
3	2	SP + 2*CR/4 (Note 2)	SP + CR/4
4	2	SP + 2*CR/4	SP + CR/4 (Note 3)
5	3	SP + 3*CR/4	SP + 2*CR/4
6	4	SP + CR	SP + 3*CR/4

Notes:

1. Step 1 is Hot Gas Bypass and is skipped when loading occurs. Hot Gas Bypass operation is inhibited during Pumpdown.
2. Step 3 is skipped when loading occurs.
3. Step 4 is skipped when unloading occurs.

* STEP can be viewed using the OPER DATA key and scrolling to COOLING DEMAND.

SYSTEM LEAD/LAG

Lead/lag between systems may be selected to help equalize average run hours between systems on chillers with 2 refrigerant systems. This may be programmed under the OPTIONS key. Auto lead/lag allows automatic lead/lag of the two systems based on average run hours of the compressors in each system. Manual lead/lag selects specifically the sequence in which the micro starts systems.

COMPRESSOR LEAD/LAG

The compressors within a system rotate starts in sequence 1, 2 or 1, 2, 3 with wraparound. The longest-off compressor in a system will start first, and the longest-running compressor in a system will turn off first. When unloading, the system with the most compressors on, unloads first. The lag system will shut down a compressor first when equal numbers of compressors are operating in each system. The micro will not attempt to equalize run time of compressors in a system.

Once the second system has started a compressor, the micro will attempt to equally load each system. Once this occurs, loading will alternate between systems.

If Soft Start is enabled on European models with this option, compressor lead/lag will function as outlined in Option 12 under the Options key.

ANTI-RECYCLE TIMER

The programmable anti-recycle timer assures that systems do not cycle. This timer is programmable under the PROGRAM key between 300 - 600 seconds. Whenever possible, to reduce cycling and motor heating, the anti-recycle timer should be adjusted to 600 seconds. The programmable anti-recycle timer starts the timer when the first compressor in a system starts. The timer begins to count down. If all of the compressors in a circuit cycle off, a compressor within the circuit will not be permitted to start until the anti-recycle timer has timed out. If the lead system has run for less than 5 minutes, 3 times in a row, the anti-recycle timer will be extended to 10 minutes.

ANTI-COINCIDENCE TIMER

This timer is not present on single-system units. Two timing controls are present in software to assure compressors within a circuit or between systems, do not start simultaneously. The anti-coincidence timer assures there is at least a one minute delay between system starts on 2-circuit systems. This timer is NOT programmable. The load timers further assure that there is a minimum time between compressor starts within a system.

EVAPORATOR PUMP CONTROL

The evaporator pump dry contacts (CTB2 – terminals 23 - 24) are energized when any of the following conditions are true:

1. Low Leaving Chilled Liquid Fault
2. Any compressor is running
3. Daily Schedule is not programmed OFF and Unit Switch is ON

The pump will not run if the micro panel has been powered up for less than 30 seconds or if the pump has run in the last 30 seconds to prevent pump motor overheating.

EVAPORATOR HEATER CONTROL

The evaporator heater is controlled by ambient air temperature. When the ambient temperature drops below 40°F (4.4°C) the heater is turned on. When the temperature rises above 45°F (7.2°C) the heater is turned off. An under voltage condition will keep the heater off until full voltage is restored to the system.

PUMPDOWN CONTROL

Each system has a pump-down feature upon shut-off. Manual pumpdown from the keypad is possible by turning off the respective system's switch under the OPTIONS key. On a non-safety, non-unit switch shutdown, all compressors but one in the system will be shut off. The LLSV or EEV will also be turned off. The final compressor will be allowed to run until the suction pressure falls below the cutout, or for 180 seconds, whichever comes first.

The EEV pilot solenoid is also used as a low superheat safety device when the EEV is selected as the expansion valve type. While the system is running and not in a pumpdown mode, the EEV pilot solenoid will close if the suction superheat falls below 4°F. The EEV pilot solenoid will open again when the superheat rises above 7.0°F. This safety device is ignored for the first 30 seconds of system run time. If the EEV pilot solenoid is closed 10 times in 2 minutes on the safety device, the low superheat safety will be triggered.

ELECTRONIC EXPANSION VALVE (EEV)

General

The EEV is optional on the YCAL0014 - YCAL0080 and standard on the YCAL0090 - YCAL0114. When the EEV is installed, it is programmed under Service Mode, which instructs the micro to control the associated outputs.

The EEV controller in the micro is a PI controller. The integration time is fixed while gain scheduling varies the proportional gain based on the superheat error. As the superheat gets smaller, the proportional gain gets smaller.

The output of the PI controller may be viewed on the display and printouts as the EEV output percentage. This output % is converted to a PWM signal that is used to control the EEV. It can over and under drive the heat motor for faster valve response. This PWM output is the percentage of a 1 second period that the 24VAC heat motor power signal is energized.

MOP Feature

The controller has an MOP feature that overrides the superheat control when the MOP setpoint is exceeded. This is generally only active during hot water starts. The MOP setpoint is 60°F saturated suction temp.

The MOP feature is also used to prevent undershoot when the suction temperature of a system being started is much higher than the return water temperature. This provides better start-up superheat control for high ambient, low water temp start-ups when the superheat measurement is high due to a warm suction line.

Valve Preheat

The heat motor is pre-heated for moderate and low ambient standby conditions. When the ambient is below 25°F, the heat motor is preheated to 25%. Between 25 and 50°F, the preheat is ramped from 25% to 0% linearly, preheat at 50°F and above is 0%.

Inputs

Two external inputs to the micro are used to control the superheat. These inputs are the suction temperature sensor input and the suction pressure transducer input.

Outputs

Two output signals are fed to the EEV. The first controls the EEV pilot solenoid portion of the valve and is 115VAC.

The second output is the EEV PWM signal which feeds the heat motor. The signal will be a 24VAC pulsed signal that is fed to the valve heat motor within a 1 second period. This 24VAC signal can be fed to the motor 0% to 100% of the 1-second period. The signal is measured in terms of watts with 100% equating to 30W, 50% to 15W, etc.

The EEV PWM signal is used to overdrive the valve for faster response. It also allows the valve to stabilize and control superheat more accurately. This feature is especially valuable at start and during transients when valve overfeed could cause liquid to be fed to the compressor.

Program

The superheat setpoint is programmable under the Program key. Superheat may be programmed for 10°F to 15°F, with 12°F as the default. It is recommended that a 12°F to 15°F setpoint be used for most applications.

Safeties

Two safeties are associated with the EEV, the low superheat safety and the sensor fault safety. Details are outlined in the System Safeties section.

CONDENSER FAN CONTROL (YCAL0014 – YCAL0080 CHILLERS)

Condenser fan operation must be programmed with the Options key under “Fan Control.” Condenser fan control can be selected for Ambient Temp. and Disch. Pressure, or Discharge Pressure Only.

The condenser fan control by “Ambient Temperature and Discharge Pressure” is a feature that is integral to the standard software control. If the optional discharge transducer is not installed, the condenser fans will operate based on outdoor ambient temperature only. See Table 27.

The condenser fan control by “Discharge Pressure” is a feature that can be selected if the discharge pressure transducer is installed and fan recycling is not a concern. Fan control by discharge pressure will work according to Table 28. The fan control on-pressure and fan differential off-pressure are programmable under the PROGRAM key.

CONDENSER FAN CONTROL (YCAL0090 – YCAL0124)

YCAL0090 - YCAL0124 fan control will be by discharge pressure only. See Tables 31 - 33.

LOW AMBIENT CONDENSER FAN CONTROL (YCAL0014 – YCAL0080)

(YCAL0090 – YCAL0124 always operate in Low Ambient Mode)

For unit operation below 25°F (-3.9°C) a low ambient kit is required. The kit consists of a discharge pressure transducer(s) and reversing contactors.

With the low ambient kit installed and the unit programmed for low ambient operation, the condenser fans will operate as shown in Tables 29 and 30 (YCAL0014 – YCAL0080) YCAL0090 – YCAL0124 is shown in Tables 31 - 33

Again, notice that condenser fan operation can be programmed for either “temperature and discharge pressure control,” or “discharge pressure control only” as described under Condenser Fan Control.

The fan control on-pressure and the fan differential off-pressure are programmable under the PROGRAM key.



A low ambient kit MUST be installed when “AMBIENT CONTROL LOW AMBIENT” is selected under the OPTIONS key on YCAL0014 – YCAL0080.



Compressor damage could occur if programming does not match installed hardware.

CONDENSER FAN CONTROL - YCAL0014 – YCAL0080

TABLE 27 – YCAL0014 – YCAL0080 CONDENSER FAN CONTROL USING OUTDOOR AMBIENT TEMPERATURE AND DISCHARGE PRESSURE (DISCHARGE PRESSURE CONTROLS WILL NOT FUNCTION UNLESS THE OPTIONAL DISCHARGE PRESSURE TRANSDUCER IS INSTALLED)

FAN STAGE	ON	OFF	CONTACTOR		MICRO BOARD OUTPUT TB-4		FAN #	
			SYS 1	SYS 2	SYS 1	SYS 2	SYS 1	SYS 2
1 1 FAN FWD	OAT >25°F (-3.9°C) OR DP > Fan Ctrl On Press	OAT < 20°F (-6.7°C) AND DP < Fan Ctrl On Press – (Diff. Press.)	8M	11M	4	8	3	4
*3 2 FAN FWD	OAT >65°F (18.3°C) OR DP > Fan Ctrl On Press + 40 PSIG (2.76 Bars)	OAT < 60°F (15.6°C) AND DP < Fan Ctrl On Press – [Diff. Press + 40 PSIG (2.76 Bars)]	7M & 8M	10M & 11M	2 & 4	6 & 8	1 & 3	2 & 4

TABLE 28 – YCAL0014 – YCAL0080 CONDENSER FAN CONTROL USING DISCHARGE PRESSURE ONLY

FAN STAGE	ON	OFF	CONTACTOR		MICRO BOARD OUTPUT TB-4		FAN #	
			SYS 1	SYS 2	SYS 1	SYS 2	SYS 1	SYS 2
1 1 FAN FWD	DP > Fan Ctrl On Press	DP < Fan Ctrl On Press – (Diff. Press.)	8M	11M	4	8	3	4
*3 2 FANS FWD	DP > Fan Ctrl On Press + 40 PSIG (2.76 Bars)	DP < Fan Ctrl On Press – [(Diff. Press.) + 40 PSIG (2.76 Bars)]	7M & 8M	10M & 11M	2 & 4	6 & 8	1 & 3	2 & 4

* NOTE: STEP 2 is not active in the “Standard Ambient” mode. When changing to “Low Ambient” control, fan power wiring also changes.

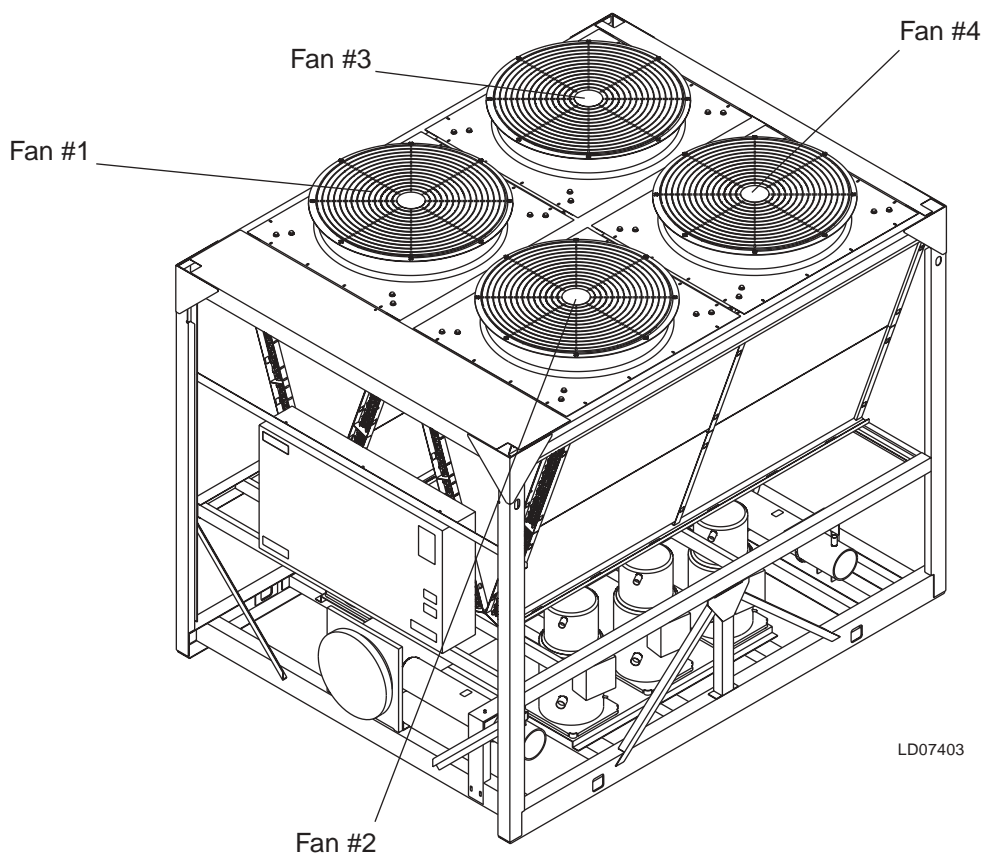

LD07403

FIG. 9 – YCAL0014 – YCAL0080 FAN LOCATION (TYPICAL)

CONDENSER FAN CONTROL - YCAL0014 – YCAL0080

TABLE 29 – YCAL0014 – YCAL0080 LOW AMBIENT CONDENSER FAN CONTROL – AMBIENT TEMPERATURE AND DISCHARGE PRESSURE CONTROL

FAN STAGE	ON	OFF	CONTACTOR		MICRO BOARD OUTPUT TB-4		FAN #	
			SYS 1	SYS 2	SYS 1	SYS 2	SYS 1	SYS 2
1 1 FAN REV	OAT >25°F (-3.9°C) OR DP > Fan Ctrl On Press.	OAT < 20°F (-6.7°C) AND DP < Fan Ctrl On Press. – Diff. Press.	7M	10M	2	6	1 REV	2 REV
2 1 FAN FWD	OAT >45°F (7.2°C) OR DP > Fan Ctrl On Press. + 20 PSIG (1.38 Bars)	OAT < 40°F (-4.40°C) AND DP < Fan Ctrl On Press. – [Diff. Press. + 20 PSIG (1.38 Bars)]	8M	11M	4	8	3 FWD	4 FWD
3 2 FANS FWD	OAT > 65°F (18.3°C) OR DP > Fan Ctrl On Press. + 40 PSIG (2.76 Bars)	OAT < 60°F (15.6°C) AND DP < Fan Ctrl On Press. – [Diff. Press. + 40 PSIG (2.76 Bars)]	8M & 9M	11M & 12M	4 & 5	8 & 9	1 & 3 FWD	2 & 4 FWD

TABLE 30 – YCAL0014 - YCAL0080 LOW AMBIENT CONDENSER FAN CONTROL – DISCHARGE PRESSURE CONTROL

FAN STAGE	ON	OFF	CONTACTOR		MICRO BOARD OUTPUT TB-4		FAN #	
			SYS 1	SYS 2	SYS 1	SYS 2	SYS 1	SYS 2
1 1 FAN REV	DP > Fan Ctrl On Press.	DP < Fan Ctrl On Press. – Diff. Press.	7M	10M	2	6	1 REV	2 REV
2 1 FAN FWD	DP > Fan Ctrl On Press. + 20 PSIG (1.38 Bars)	DP < Fan Ctrl On Press. – [Diff. Press. + 20 PSIG (1.38 Bars)]	8M	11M	4	8	3 FWD	4 FWD
3 2 FANS FWD	DP > Fan Ctrl On Press. + 40 PSIG (2.76 Bars)	DP < Fan Ctrl On Press. – [Diff. Press. + 40 PSIG (2.76 Bars)]	8M & 9M	11M & 12M	4 & 5	8 & 9	1 & 3 FWD	2 & 4 FWD

CONDENSER FAN CONTROL - YCAL0090 – YCAL0124

CONDENSER FAN CONTROL (YCAL0090 – YCAL0124 CHILLERS)

Condenser fan control on models YCAL0090 – YCAL0124 will always be by discharge pressure. The on pressure and the differential off pressure are programmable under the PROGRAM key.

The following Figures and Tables outline fan sequencing for the various models. These models are equipped to operate to 0°F ambient as a standard.

TABLE 31 – YCAL0090 - YCAL0094 CONDENSER FAN CONTROL

FAN STAGE	ON	OFF	CONTACTOR		MICRO BOARD OUTPUT TB-4		FAN #	
			SYS 1	SYS 2	SYS 1	SYS 2	SYS 1	SYS 2
1 1 FAN FWD	DP > Fan Ctrl On Press	DP < Fan Ctrl On Press – (Diff. Press.)	9M	13M	2	6	5	6
2 2 FANS FWD	DP > Fan Ctrl On Press + 20 PSIG (1.38 Bars)	DP < Fan Ctrl On Press – [(Diff. Press.) + 20 PSIG (1.38 Bars)]	8M & 9M	12M & 13M	2 & 4	6 & 8	3 & 5	4 & 6
3 3 FANS FWD	DP > Fan Ctrl On Press + 40 PSIG (2.76 Bars)	DP < Fan Ctrl On Press – [(Diff. Press.) + 40 PSIG (2.76 Bars)]	7M, 8M, & 9M	11M, 12M & 13M	2, 4 & 5	6, 8 & 9	1, 3 & 5	2, 4 & 6

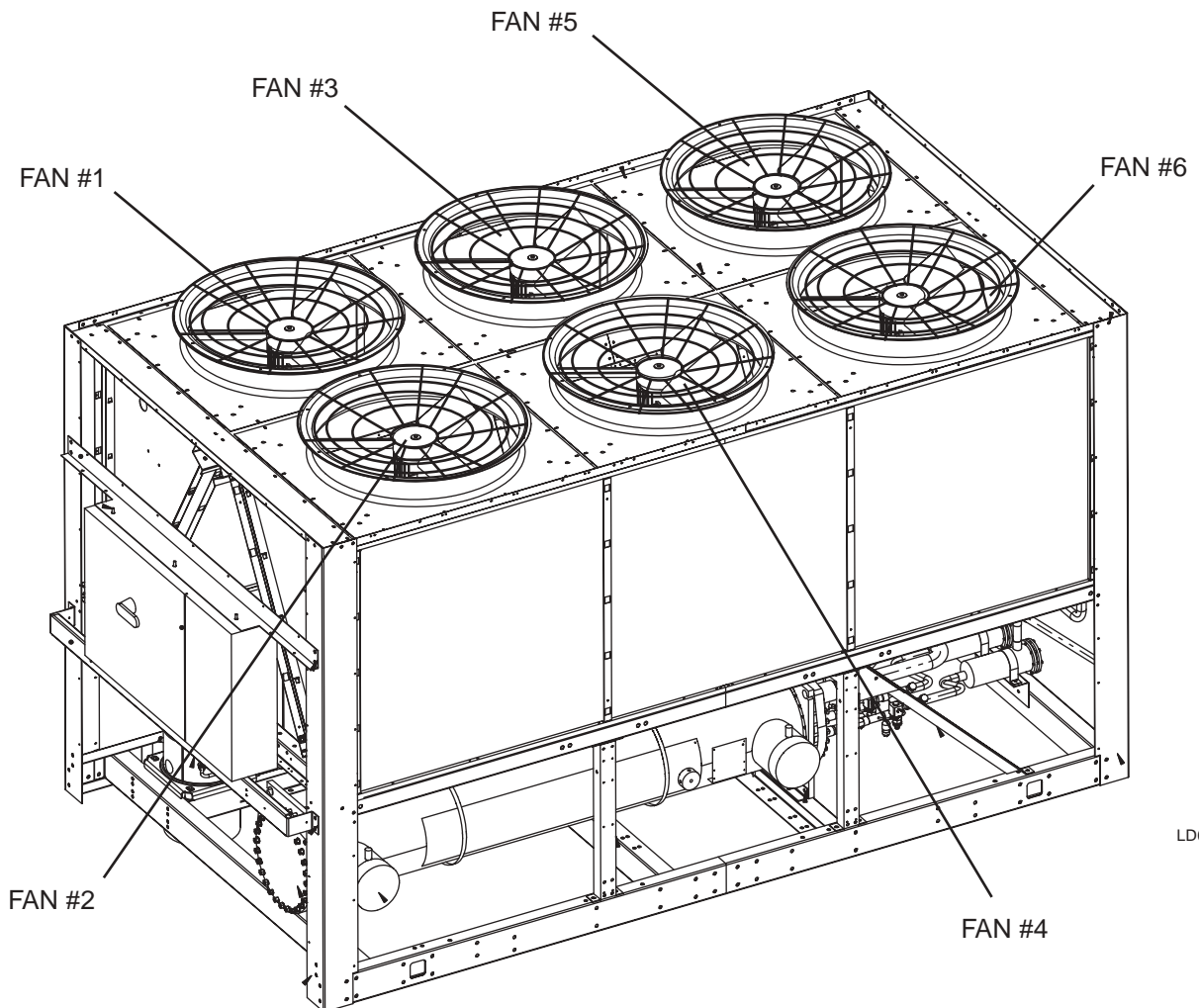

LD07828

FIG. 10 – YCAL0104 – YCAL0104 FAN LOCATION

CONDENSER FAN CONTROL - YCAL0114 – YCAL0124

TABLE 32 – YCAL0114 - YCAL0124 CONDENSER FAN CONTROL

FAN STAGE	ON	OFF	CONTACTOR		MICRO BOARD OUTPUT TB-4		FAN #	
			SYS 1	SYS 2	SYS 1	SYS 2	SYS 1	SYS 2
1 1 FAN FWD	DP > Fan Ctrl On Press	DP < Fan Ctrl On Press – (Diff. Press.)	10M	14M	2	6	7	8
2 2 FANS FWD	DP > Fan Ctrl On Press + 20 PSIG (1.38 Bars)	DP < Fan Ctrl On Press – [(Diff. Press.) + 20 PSIG (1.38 Bars)]	9M & 10M	13M & 14M	2 & 4	6 & 8	5 & 7	6 & 8
3 3 FANS FWD	DP > Fan Ctrl On Press + 40 PSIG (2.76 Bars)	DP < Fan Ctrl On Press – [(Diff. Press.) + 40 PSIG (2.76 Bars)]	7M, 8M, & 10M	11M, 12M & 14M	2 & 5	6 & 9	1, 3 & 7	2, 4 & 8
4 4 FANS FWD	DP > Fan Ctrl On Press + 60 PSIG (4.14 Bars)	DP < Fan Ctrl On Press – [(Diff. Press.) + 60 PSIG (4.14 Bars)]	7M, 8M, 9M, 10M	11M, 12M, 13M, 14M	2, 4 & 5	6, 8 & 9	1, 3, 5, 7	2, 4, 6, 8

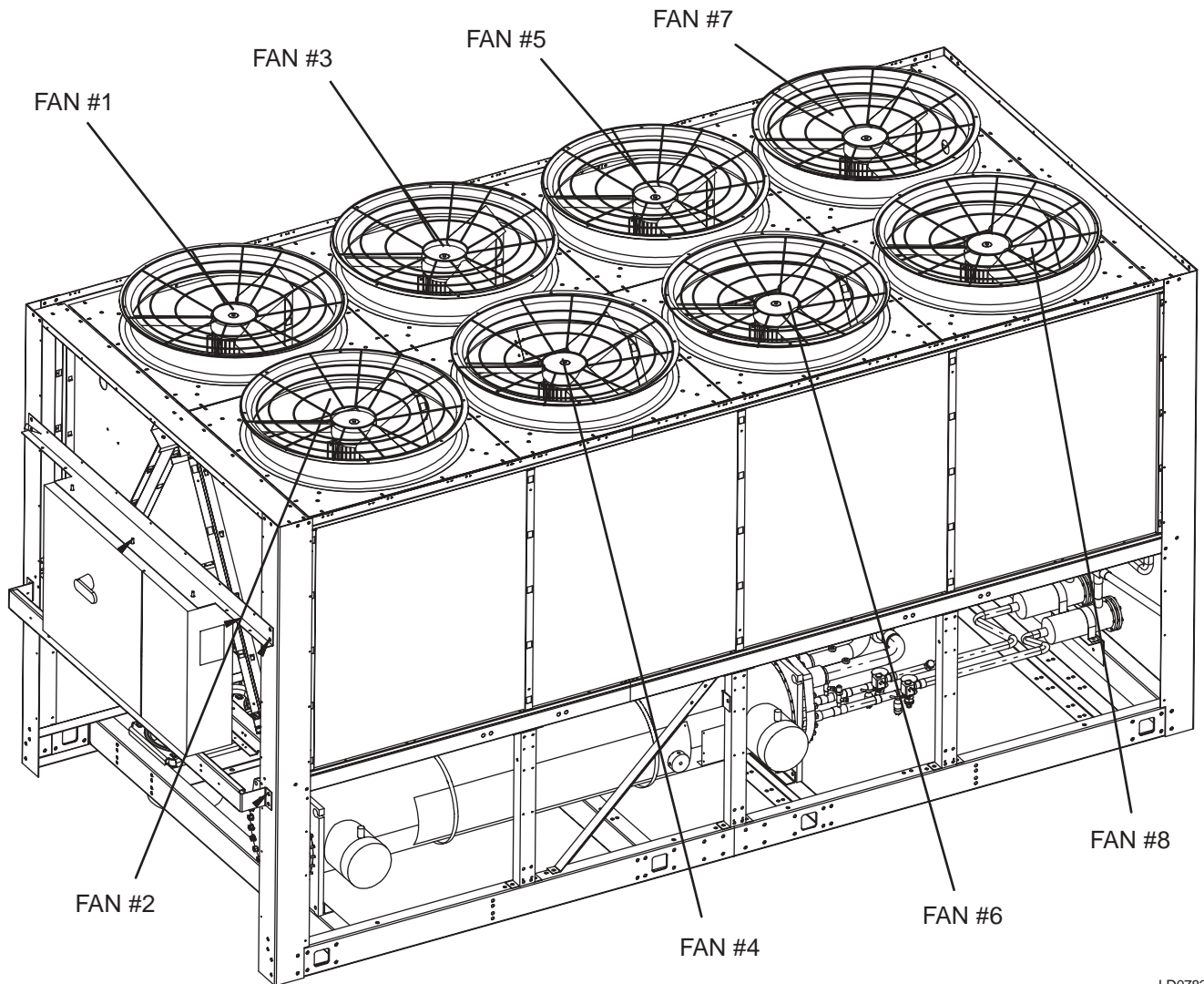

LD07829

FIG. 11 – YCAL0114 – YCAL0124 FAN LOCATION

This page intentionally left blank .

LOAD LIMITING

Load Limiting is a feature that prevents the unit from loading beyond the desired value. 2 and 4 compressor units can be load limited to 50%. This would allow only 1 compressor per system to run. 3 and 6 compressor units can be load limited to 33% or 66%. The 66% limit would allow up to 2 compressors per system to run, and the 33% limit would allow only 1 compressor per system to run. Five-compressor units may be load limited to 40% (1 compressor per system runs) or 80% (up to 2 compressors per system) are permitted to run. No other values of limiting are available.

There are two ways to load limit the unit. The first is through remote communication via an ISN.

A second way to load limit the unit is through closing contacts connected to the Load Limit (CTB1 – Terminals 13 - 21) and PWM inputs (CTB1 – Terminals 13 - 20). Stage 1 of load limiting involves closing the Load Limit input. Stage 2 of load limiting involves closing both the Load Limit and PWM inputs. The first stage of limiting is either 80%, 66% or 50%, depending on the number of compressors on the unit. The second stage of limiting is either 40% or 33% and is only available on 3, 5 & 6 compressor units. Table 34 shows the load limiting permitted for the various number of compressors.

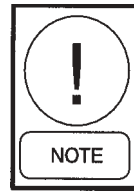

Simultaneous operation of Load Limiting and EMS-PWM Temperature Reset (described on following pages) cannot occur.

COMPRESSOR RUN STATUS

Compressor run status is indicated by closure of contacts at CTB2 – terminals 25 to 26 for system 1 and CTB2 – terminals 27 to 28 for system 2.

ALARM STATUS

System or unit shutdown is indicated by normally-open alarm contacts opening whenever the unit shuts down on a unit fault, or locks out on a system fault. System 1 alarm contacts are located at CTB2 – terminals 29 to 30. System 2 alarm contacts are located at CTB2 – terminals 31 to 32. The alarm contacts will close when conditions allow the unit to operate.

TABLE 33 – COMPRESSOR OPERATION – LOAD LIMITING

COMPRESSORS IN UNIT	STAGE 1	STAGE 2
2	50%	–
3	66%	33%
4	50%	–
5	80%	40%
6	66%	33%

EMS-PWM REMOTE TEMPERATURE RESET

EMS-PWM Remote Temperature Reset is a value that resets the Chilled Liquid Setpoint based on a PWM input (timed contact closure) to the microboard. This PWM input would typically be supplied by an Energy Management System.

A contact closure on the PWM Temp Reset input at CTB1 terminals 13 - 20, will reset the chilled liquid setpoint based on the length of time the contacts remain closed. The maximum temperature reset is achieved at a contact closure of 11 seconds. This is the longest contact closure time allowed. One second is the shortest time allowed and causes the Chilled Liquid Setpoint to revert back to the Local programmed value. The reset value is always added to the Chilled Liquid Setpoint, meaning that this function never lowers the Chilled Liquid Setpoint below the locally programmed value, it can only reset to a higher value. The microboard must be refreshed between 30 seconds and 30 minutes. Any contact closure occurring sooner than 30 seconds will be ignored. If more than 30 minutes elapse before the next contact closure, the setpoint will revert back to the locally programmed value. The new chilled liquid setpoint is calculated by the following equations:

$$\text{setpoint} = \text{local chilled liquid setpoint} + \text{°reset}$$

$$\text{°reset} = \frac{(\text{Contact Closure} - 1) \times (\text{*Max. Reset Value})}{10}$$

Example:

Local Chilled Liquid Setpoint = 45°F (7.22°C).

*Max Reset Value = 10°F (5.56°C)

Contact Closure Time = 6 Seconds.

(English)

$$(6 \text{ sec.} - 1) (10^\circ\text{F}/10) = 5^\circ\text{F Reset}$$

So...the new chilled liquid setpoint = 45°F + 5°F = 50°F. This can be viewed by pressing the Cooling Setpoints key twice. The new value will be displayed as "REM SETP = 50.0°F."

(Metric)

$$(6 \text{ sec} - 1) * (5.56^\circ\text{C}/10) = 2.78^\circ\text{C}$$

$$\text{Reset Cooling Setpoint} = 7.22^\circ\text{C} + 2.78^\circ\text{C} = 10.0^\circ\text{C}$$

So...the new reset Cooling Setpoint = 7.22 °C + 2.78°C = 10°C. This can be viewed by pressing the Cooling Setpoints key twice. The new value will be displayed as "REM SETP = 10.0°C."

BAS/EMS TEMPERATURE RESET OPTION

The Remote Reset Option allows the Control Center of the unit to reset the chilled liquid setpoint using a 0 - 10VDC input, a 4-20mA input, or a contact closure input. The Remote Reset circuit board converts the signals mentioned above into pulse width modulated (PWM) signals which the microprocessor can understand. Whenever a reset is called for, the change may be noted by pressing the Cooling Setpoints key twice. The new value will be displayed as "REM SETP = XXX°F."

The optional Remote Reset option would be used when reset of the chilled liquid setpoint is required and a PWM signal (timed contact closure) cannot be supplied by an Energy Management System. The Remote Temp. Reset Board will convert a voltage, current, or contact signal that is available from an EMS to a PWM signal, and every 80 seconds provide a PWM input to the microboard. Figure 13 shows a diagram of the field and factory electrical connections.

If a **0 - 10VDC** signal is available, it is applied to terminals A+ and A-, and **jumper are applied to JU4 and JU2** on the reset board. This DC signal is conditioned to a 1 - 11 second PWM output and supplied to the PWM input on the microboard at CTB1 terminals 13 - 20. To calculate the reset chilled liquid setpoint for values between 0VDC and 10VDC use the following formula:

$$\text{setpoint} = \text{local chilled liquid setpoint} + \text{°reset}$$

$$\text{°reset} = \frac{(\text{DC voltage signal}) \times (\text{*Max Reset Value})}{10}$$

Example:

Local Chilled Liquid Setpoint = 45°F (7.22°C)

*Max Reset Value = 20°F (11.11°C)

Input Signal = 6VDC

(English)

$$\text{°reset} = \frac{6\text{VDC} \times 20^\circ\text{F}}{10} = 12^\circ\text{F reset}$$

$$\text{setpoint} = 45^\circ\text{F} + 12^\circ\text{F} = 57^\circ\text{F}$$

(Metric)

$$\text{°reset} = \frac{6\text{VDC} \times 11.11^\circ\text{C}}{10} = 6.67^\circ\text{C reset}$$

$$\text{setpoint} = 7.22^\circ\text{C} + 6.67^\circ\text{C} = 13.89^\circ\text{C}$$

* Max Reset Value is the "Max EMS-PWM Remote Temp. Reset" setpoint value described in the programming section under COOLING SETPOINTS. Programmable values are from 2°F to 40°F (1.11°C to 22.22°C).

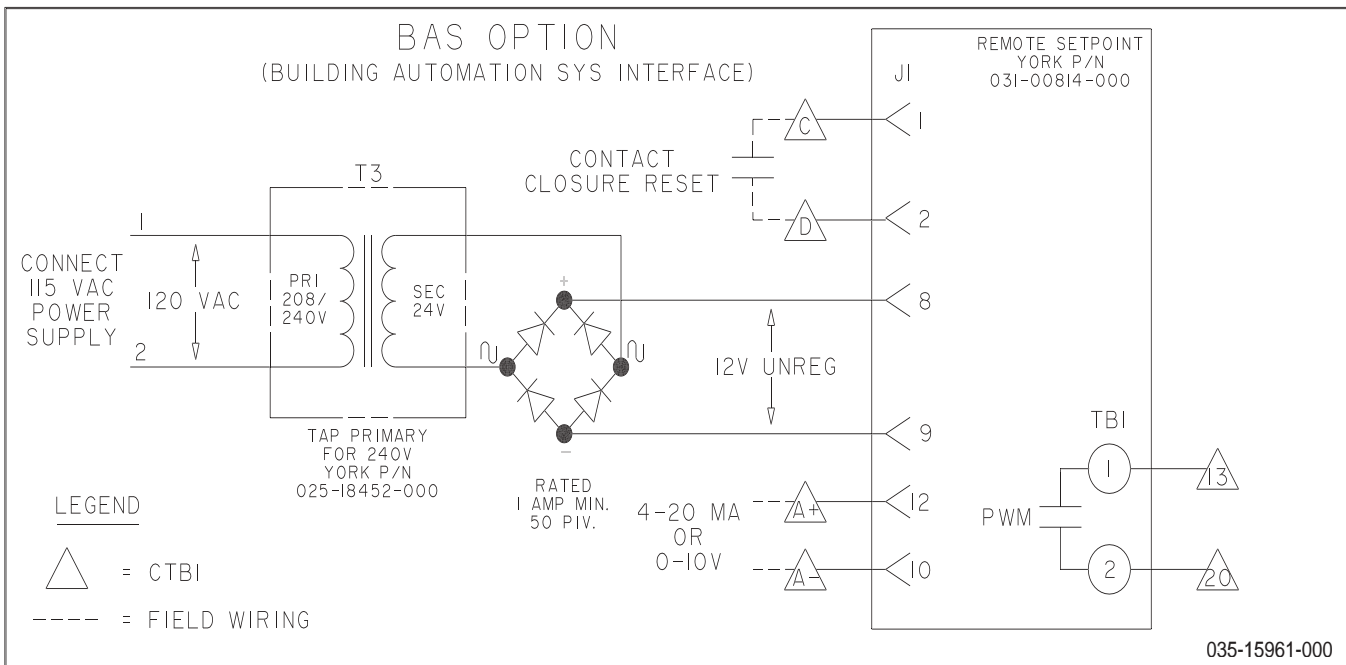

**FIG. 12 – FIELD AND FACTORY ELECTRICAL CONNECTIONS
OPTIONAL REMOTE TEMPERATURE RESET BOARD**

LD03875

If a **4-20mA signal** is available, it is applied to terminals A+ and A- and **jumper JU5 and JU3** on the reset board. The mA signal is conditioned to a 1 - 11 second PWM output. The PWM output is then supplied to the PWM input on the microboard at CTB1 terminals 13 - 20. To calculate the chilled liquid setpoint for values between 4mA and 20 mA use the following formula:

$$\text{setpoint} = \text{local chilled liquid setpoint} + \text{°reset}$$

$$\text{°reset} = \frac{(\text{mA signal} - 4) \times (\text{*Max Reset Value})}{16}$$

Example:

Local Chilled Liquid Setpoint = 45° (7.22°C)

*Max Reset Value = 10°F (5.56°C)

Input Signal = 12 mA

(English)

$$\text{°reset} = \frac{8\text{mA} \times 10\text{°F}}{16} = 5\text{°F reset}$$

$$\text{setpoint} = 45\text{°F} + 5\text{°F} = 50\text{°F}$$

(Metric)

$$\text{°reset} = \frac{8\text{mA} \times 5.56\text{°C}}{16} = 2.78\text{°C reset}$$

$$\text{setpoint} = 7.22\text{°C} + 2.78\text{°C} = 10.0\text{°C}$$

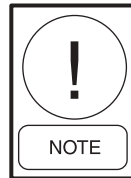

A 240-24 Volt Ratio Transformer (T3) is used to derive nominal 12 volt output from the 120 volt supply.

If the **Contact Closure** input is used. The connections are made to terminals C and D and only **jumper JU1 must be in place** on the reset board. This input is used when a *single* reset value is needed. When the contacts are closed, the remote temperature reset board will convert this contact closure to a PWM signal that is applied to CTB1 terminals 13 - 20.

To set the PWM output, the contacts must be closed on inputs C - D, and potentiometer R11 (located on the front edge of the PC board) is adjusted to 10VDC as measured at TP3 to terminal 10 on the circuit board. The reset value will be the "Max EMS-PWM Remote Temp. Reset" setpoint value programmed in the SETPOINTS section under the Cooling Setpoints key.



The coil of any added relay used for reset must be suppressed to prevent possible component damage. Use YORK PN031-00808-000 suppressor.

* Max Reset Value is the "Max EMS-PWM Remote Temp. Reset" setpoint value described in the programming section under Cooling Setpoints. Programmable values are from 2°F to 40°F (1.11°C to 11.11°C).

SERVICE AND TROUBLESHOOTING

CLEARING HISTORY BUFFERS

The history buffers may be cleared by pressing the HISTORY key and then repeatedly pressing the UP arrow key until you scroll past the last history buffer choice. The following message will be displayed:

```
INITIALIZE HISTORY
ENTER = YES
```

Pressing the ENTER/ADV key at this display will cause the history buffers to be cleared. Pressing any other key will cancel the operation.



DO NOT CLEAR BUFFERS. Important information may be lost. Contact factory service.

SOFTWARE VERSION

The software version may be viewed by pressing the HISTORY key and then repeatedly pressing the DOWN arrow key until you scroll past the first history buffer choice. The following message is an example of what will be displayed:

```
SOFTWARE VERSION
C . M M C . 0 1 . 0 1
```

SERVICE MODE

Service Mode is a mode that allows the user to enable or disable all of the outputs (except compressors) on the unit, change chiller configuration setup parameters and view all the inputs to the microboard.

To enter Service Mode, turn the unit switch off and press the following keys in the sequence shown; PROGRAM, UP ARROW, UP ARROW, DOWN ARROW, DOWN ARROW, ENTER. Service Mode will time out after 30 minutes and return to normal control mode, if the panel is accidentally left in this mode. Otherwise, turning the unit switch on will take the panel out of Service Mode.

SERVICE MODE – OUTPUTS

After pressing the key sequence as described, the control will enter Service Mode permitting the *outputs (except compressors), operating hours, refrigerant type, ex-*

pansion valve type, and start/hour counters to be viewed/modified. The ENTER/ADV key is used to advance through the outputs. Using the UP/DOWN ARROW keys will turn the respective digital output on/off or modify the value.

Following is the order of outputs that will appear as the ENTER/ADV key is pressed:

```
SYS 1 COMP 1 STATUS TB3-2 IS:
SYS 1 LLSV STATUS TB3-3 IS:
SYS 1 COMP 2 STATUS TB3-4 IS:
SYS 1 COMP 3 STATUS TB3-5 IS:
SYS 1 HGBP STATUS TB3-6 IS:
SYS 2 COMP 1 STATUS TB3-8 IS:
SYS 2 LLSV STATUS TB3-9 IS:
SYS 2 COMP 2 STATUS TB3-10 IS:
SYS 2 COMP 3 STATUS TB4-1 IS:
SYS 1 FAN OUTPUT 1 TB4-2 IS:
SYS 1 FAN OUTPUT 2 TB4-4 IS:
SYS 1 FAN OUTPUT 3 TB4-5 IS:
SYS 2 FAN OUTPUT 1 TB4-6 IS:
SYS 2 FAN OUTPUT 2 TB4-8 IS:
SYS 2 FAN OUTPUT 3 TB4-9 IS:
EVAP HEATER STATUS TB4-10 IS:
SYS 1 ALARM STATUS TB5-1 IS:
SYS 2 ALARM STATUS TB5-2 IS:
EVAP PUMP STATUS TB5-3 IS:
SYS 1 EEV OUTPUT J10 - 1, 2 = :
SYS 2 EEV OUTPUT J10 - 3, 4 = :
ANALOG OUTPUT 3 J10 - 5, 6 = :
ANALOG OUTPUT 4 J10 - 7, 8 = :
```

Each display will also show the output connection on the microboard for the respective output status shown. For example:

```
SYS 1 LLSV STATUS
TB3 - 2 IS OFF
```

This display indicates that the system 1 liquid line solenoid valve is OFF, and the output connection from the microboard is coming from terminal block 3 - pin 2.

Pressing the UP Arrow key will energize the liquid line solenoid valve and OFF will change to ON in the display as the LLSV is energized.

SERVICE MODE – CHILLER CONFIGURATION

After the Outputs are displayed, the next group of displays relate to chiller configuration and start/hour counters. Data logging, soft start, refrigerant type, and expansion valve type all must be programmed to match actual chiller configuration.



Soft start, Refrigerant Type, and Expansion Valve Type MUST be properly programmed or damage to compressors and other system components may result.

Following is a list, in order of appearance:

- DATA LOGGING MODE = : DO NOT MODIFY
- DATA LOGGING TIMER = : DO NOT MODIFY
- SOFT START
- REFRIGERANT TYPE
- EXPANSION VALVE TYPE
- SYS 1 HOURS
- SYS 2 HOURS
- SYS 1 STARTS
- SYS 2 STARTS

The last displays shown on the above list is for the accumulated run and start timers for each system. All values can also be changed using the UP and Down ARROW keys, but under normal circumstances would not be advised. After the last start display, the micro will display the first programmable value under the PROGRAM key.

SERVICE MODE – INPUTS

After entering Service Mode (PROGRAM ↑↑ ↓↓), all digital and analog inputs to the microboard can be viewed by pressing the OPER DATA key. After pressing the OPER DATA key, the UP ARROW and DOWN ARROW keys are used to scroll through the analog and digital inputs.

Following is the order of analog and digital inputs that will appear when sequenced with the ↓ (Down) ARROW key: (analog inputs)

- SYS 1 *SUCTION PRESSURE
- UNIT TYPE
- SYS 1 **DISCH PRESSURE
- SYS 1*** COOLER INLET REFRIG. TEMP.
- SYS 2*** COOLER INLET REFRIG. TEMP.
- SYS 1**** SUCTION TEMP.
- SYS 2**** SUCTION TEMP.
- AMBIENT AIR TEMP.
- LEAVING LIQUID TEMP.

- RETURN LIQUID TEMP.
- SYS 2 *SUCTION PRESSURE
- SYS 2 SPARE
- SYS 2 **DISCH PRESSURE
- SYS 1 MTR VOLTS
- SYS 2 MTR VOLTS

(digital inputs)

- PWM TEMP RESET INPUT
- LOAD LIMIT INPUT
- FLOW SW / REM START
- SPARE
- SINGLE SYSTEM SELECT
- SYS 1 MP / HPCO INPUT
- SYS 2 MP / HPCO INPUT

- * The suction pressure transducer is optional on YCAL0014 - YCAL0060. A low pressure switch is standard on these models in place of the suction transducer.
- ** The discharge pressure transducer is optional on some models.
- *** The cooler inlet refrigerant temp. sensor is on R-407c units only.
- ****The suction temp. sensor is on EEV units only.

The analog inputs will display the input connection, the temperature or pressure, and corresponding input voltage such as:



This example indicates that the system 1 suction pressure input is connected to plug 4 - pin 10 (J4-10) on the microboard. It indicates that the voltage is 2.1 volts dc which corresponds to 81 PSIG (5.6 bars) suction pressure.

The digital inputs will display the input connection and ON/OFF status such as:



This indicates that the flow switch/remote start input is connected to plug 9- pin 5 (J9-5) on the microboard, and is ON (ON = +30VDC unregulated input, OFF = 0VDC input on digital inputs).

CONTROL INPUTS/OUTPUTS

Tables 34 through 37 are a quick reference list providing the connection points and a description of the inputs and outputs respectively. All input and output connections pertain to the connections at the microboard.

Figure 13 illustrates the physical connections on the microboard.

TABLE 34 – MICROBOARD DIGITAL INPUTS

*J9-1	30VDC UNREGULATED SUPPLY
J9-2	UNIT ON/OFF SWITCH
J9-3	PWM TEMP RESET OR LOAD LIMIT STAGE 2 ON 3, 5 & 6 COMP UNITS
J9-4	LOAD LIMIT STAGE 1
J9-5	FLOW SWITCH AND REMOTE START / STOP
J9-6	SPARE
J9-7	SINGLE SYSTEM SELECT (JUMPER = SINGLE SYS, NO JUMPER=TWO SYS)
J9-8	CR1 (SYS 1 MOTOR PROTECTOR / HIGH PRESS CUTOUT)
J9-9	CR2 (SYS 2 MOTOR PROTECTOR / HIGH PRESS CUTOUT)

TABLE 36 – MICROBOARD DIGITAL OUTPUTS

TB3-2	SYS 1 COMPRESSOR 1
TB3-3	SYS 1 LIQUID LINE SOLENOID VALVE OR EEV PILOT SOLENOID
TB3-4	SYS 1 COMPRESSOR 2
TB3-5	SYS 1 COMPRESSOR 3
TB3-6	SYS 1 HOT GAS BYPASS VALVE
TB3-8	SYS 2 COMPRESSOR 1
TB3-9	SYS 2 LIQUID LINE SOLENOID VALVE OR EEV PILOT SOLENOID
TB3-10	SYS 2 COMPRESSOR 2
TB4-1	SYS 2 COMPRESSOR 3
TB4-2	SYS 1 CONDENSER FAN OUTPUT 1
TB4-4	SYS 1 CONDENSER FAN OUTPUT 2
TB4-5	SYS 1 CONDENSER FAN OUTPUT 3
TB4-6	SYS 2 CONDENSER FAN OUTPUT 1
TB4-8	SYS 2 CONDENSER FAN OUTPUT 2
TB4-9	SYS 2 CONDENSER FAN OUTPUT 3
TB4-10	EVAPORATOR HEATER
TB5-1	SYS 1 ALARM
TB5-2	SYS 2 ALARM
TB5-3	EVAPORATOR PUMP STARTER

TABLE 35 – MICROBOARD ANALOG INPUTS

J4-10	SYS 1 SUCTION PRESS TRANSDUCER OR SYS 1 LOW PRESS SWITCH
J4-11	UNIT TYPE: CHILLER = NO JUMPER J4-6 TO J4-11 YCUL CONDENSING UNIT = JUMPER J4-6 TO J4-11
J4-12	SYS 1 DISCHARGE PRESSURE TRANSDUCER (OPTIONAL)
J5-11	SPARE
J5-12	SYS 1 COOLER INLET REFRIGERANT TEMP SENSOR (R-407C)
J5-13	SYS 2 COOLER INLET REFRIGERANT TEMP. SENSOR (R-407C)
J5-14	SYS 1 SUCTION TEMP SENSOR (EEV OPTION)
J5-15	SYS 2 SUCTION TEMP SENSOR (EEV OPTION)
J6-7	AMBIENT AIR TEMPERATURE SENSOR
J6-8	LEAVING CHILLED LIQUID TEMPERATURE SENSOR
J6-9	RETURN CHILLED LIQUID TEMPERATURE SENSOR
J7-10	SYS 2 SUCTION PRESSURE TRANSDUCER OR SYS 2 LOW PRESSURE SWITCH
J7-11	SPARE
J7-12	SYS 2 DISCHARGE PRESSURE TRANSDUCER (optional)
J8-5	UNIT/SYS 1 VOLTAGE
J8-6	SYS 2 VOLTAGE

TABLE 37 – MICROBOARD ANALOG OUTPUTS

J10-1/J10-2	SYS 1 EEV OUTPUT
J10-3/J10-4	SYS 2 EEV OUTPUT
J10-5/J10-6	SPARE
J10-7/J10-8	SPARE

* The 30 dc unregulated supply is not an input. This voltage originates on the microboard and is used to supply the contacts for the digital inputs.

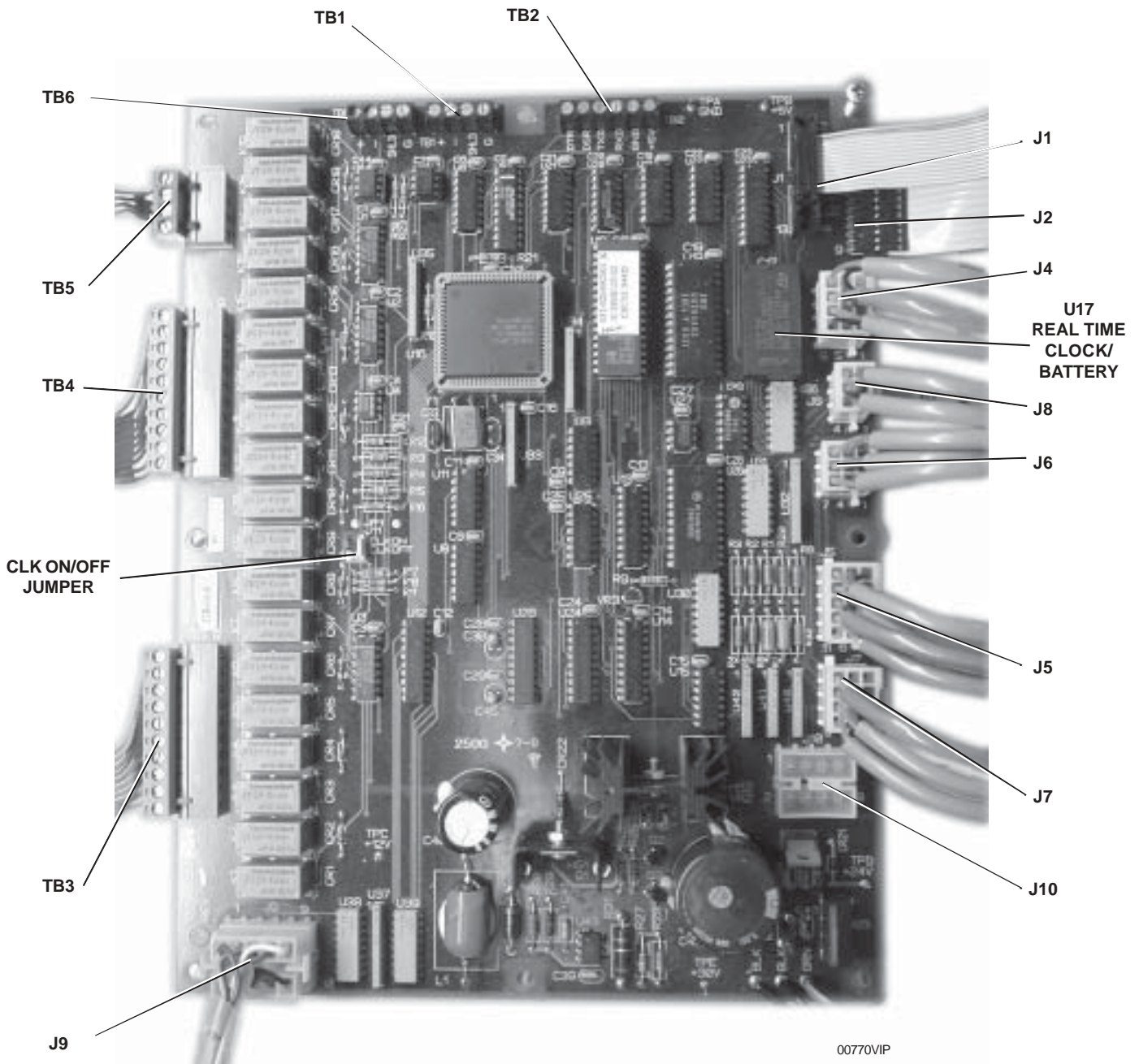

FIG. 13 – MICROBOARD LAYOUT

CHECKING INPUTS AND OUTPUTS

DIGITAL INPUTS

Refer to the unit wiring diagram. All digital inputs are connected to J9 of the microboard. The term “digital” refers to two states – either on or off. As an example, when the flow switch is closed, 30 volts **DC** will be applied to J9, pin 5 (J9-5) of the microboard. If the flow switch is open, 0 volts DC will then be present at J9-5.

Pin 1 of J9 is an *unregulated* 30VDC that is the **DC** voltage **source** used to supply the DC voltage to the various contacts, unit switch, flow switch, etc. This DC source is factory wired to CTB1, terminal 13. Any switch or contact used as a digital input would be connected to this terminal, with the other end connecting to its respective digital input on the microboard. Any time a switch or contact is closed, 30VDC would be applied to that particular digital input. Any time a switch or contact is open, 0VDC would be applied to that particular digital input.

Typically, as high as 34VDC could be measured for the DC voltage on the digital inputs. This voltage is in reference to ground. The unit case should be sufficient as a reference point when measuring digital input voltages.

ANALOG INPUTS – Temperature

Refer to the unit wiring diagram. Temperature inputs are connected to the microboard on plug J6. These **analog** inputs represent varying DC signals corresponding to varying temperatures. All voltages are in reference to the unit case (ground). Following are the connections for the temperature sensing inputs:

Outside Air Sensor

J6-4 = +5VDC regulated supply to sensor.

J6-7 = VDC input signal to the microboard. See Table 45 for voltage readings that correspond to specific outdoor temperatures.

J6-1 = drain (shield connection = 0VDC)

TABLE 38 – OUTDOOR AIR SENSOR TEMPERATURE/VOLTAGE/RESISTANCE CORRELATION

TEMP °F	VOLTAGE	RESISTANCE	TEMP C°
0	0.7	85398	-18
5	0.8	72950	-15
10	0.9	62495	-12
15	1.0	53685	-9
20	1.1	46240	-7
25	1.2	39929	-4
30	1.4	34565	-1
35	1.5	29998	2
40	1.7	26099	4
45	1.8	22673	7
50	2.0	19900	10
55	2.2	17453	13
60	2.3	15309	16
65	2.5	13472	18
70	2.6	11881	21
75	2.8	10501	24
80	2.9	9298	27
85	3.1	8250	29
90	3.2	7332	32
95	3.4	6530	35
100	3.5	5827	38
105	3.6	5209	41
110	3.7	4665	43
115	3.8	4184	46
120	3.9	3759	49
125	4.0	3382	52
130	4.1	3048	54

TABLE 39 – ENTERING/LEAVING CHILLED LIQUID TEMP. SENSOR, COOLER INLET TEMPERATURE SENSOR, AND SUCTION TEMPERATURE SENSOR: TEMPERATURE/VOLTAGE/RESISTANCE CORRELATION

TEMP °F	VOLTAGE	RESISTANCE	TEMP °C
0	1.71	25619	-18
2	1.78	24046	-17
4	1.85	22580	-16
6	1.93	21214	-14
8	2.00	19939	-13
10	2.07	18749	-12
12	2.15	17637	-11
14	2.22	16599	-10
16	2.30	15629	-9
18	2.37	14721	-8
20	2.45	13872	-7
22	2.52	13077	-6
24	2.59	12333	-4
26	2.67	11636	-3
28	2.74	10982	-2
30	2.81	10370	-1
32	2.88	9795	0
34	2.95	9256	1
36	3.02	8750	2
38	3.08	8276	3
40	3.15	7830	4
42	3.21	7411	6
44	3.27	7017	7
46	3.33	6647	8
48	3.39	6298	9
50	3.45	5970	10
52	3.51	5661	11
54	3.56	5370	12
56	3.61	5096	13
58	3.67	4837	14
60	3.72	4593	16
62	3.76	4363	17
64	3.81	4145	18
66	3.86	3941	19
68	3.90	3747	20
70	3.94	3564	21
72	3.98	3392	22
74	4.02	3228	23
76	4.06	3074	24
78	4.10	2928	26
80	4.13	2790	27

Entering Chilled Liquid Sensor

- J6-6 = +5VDC regulated supply to sensor.
- J6-9 = VDC input signal to the microboard. See Table 46 for voltage readings that correspond to specific liquid temperatures.
- J6-3 = drain (shield connection = 0VDC)

Leaving Chilled Liquid Temp. Sensor

- J6-5 = +5VDC regulated supply to sensor.
- J6-8 = VDC input signal to the microboard. See Table 46 for voltage readings that correspond to specific liquid temperatures.
- J6-2 = drain (shield connection = 0VDC)

Cooler Inlet Temperature

- J5-12 = VDC input signal to microboard from Sys 1 Cooler Inlet Refrigerant Temp Sensor (R-407c only).
- J5-13 = VDC input signal to microboard from Sys 2 Cooler Inlet Refrigerant Temp Sensor (R-407c only).

Suction Temp Sensor

- J5-14 = VDC input signal to microboard from Sys 1 Suction Temp Sensor (EEV only).
- J5-15 = VDC input signal to microboard from Sys 2 Suction Temp Sensor (EEV only).

ANALOG INPUTS – Pressure

Refer to the unit wiring diagram. Pressure inputs are connected to the microboard on plugs J4 and J7. These **analog** inputs represent varying dc signals corresponding to varying pressures. All voltages are in reference to the unit case (ground).

System 1 discharge and suction pressures will be connected to J4 of the microboard. System 2 discharge and suction pressure transducers will be connected to J7 of the microboard.

The discharge transducers are optional on all units except the YCAL0090 – YCAL0124. If the discharge transducers are not installed, no connections are made to the microboard and the discharge pressure readout on the display would be zero.

The suction pressure transducers are optional on YCAL0014 - YCAL0060. If the suction transducers are not installed, a mechanical low pressure switch will be installed in its place, and the suction pressure readout on the display will be 0 PSIG when the LP switch is open, and 200 PSIG (13.79 BARG) when the LP switch is closed.

The discharge transducers have a range from 0 to 400 PSIG. The output will be linear from .5VDC to 4.5VDC over the 400 PSIG (27.5 BARG) range. Following is the formula that can be used to verify the voltage output of the transducer. All voltage reading are in reference to ground (unit case).

$$V = (\text{Pressure in PSIG} \times .01) + .5$$

or

$$V = (\text{Pressure in BARG} \times .145) + .5$$

where V = dc voltage output

Pressure = pressure sensed by transducer

The microboard connections for the Discharge Transducers:

System 1 Discharge Transducer

J4-7 = +5VDC regulated supply to transducer.

J4-12 = VDC input signal to the microboard. See the formula above for voltage readings that correspond to specific discharge pressures.

J4-8 = +5VDC return

J4-9 = drain (shield connection = 0VDC)

System 2 Discharge Transducer

J7-7 = +5VDC regulated supply to transducer.

J7-12 = VDC input signal to the microboard. See the formula above for voltage readings that correspond to specific discharge pressures.

J7-8 = +5VDC return

J7-9 = drain (shield connection = 0VDC)

The suction transducers have a range from 0 to 200 PSIG (13.79 BARG). The output will be linear from .5VDC to 4.5VDC over the 200 PSIG (13.79 BARG) range. Following is a formula that can be used to verify the voltage output of the transducer. All voltage reading are in reference to ground (unit case).

$$V = (\text{Pressure in PSIG} \times .02) + .5$$

or

$$V = (\text{Pressure in BARG} \times .29) + .5$$

where V = dc voltage input to micro
Pressure = pressure sensed by transducer

Following are the microboard connections for the Suction Transducer:

System 1 Suction Transducer

- J4-5 = +5VDC regulated supply to transducer.
- J4-10 = VDC input signal to the microboard. See the formula above for voltage readings that correspond to specific suction pressures.
- J4-1 = +5VDC return
- J4-2 = drain (shield connection = 0VDC)

System 2 Suction Transducer

- J7-5 = +5VDC regulated supply to transducer.
- J7-10 = VDC input signal to the microboard. See the formula above for voltage readings that correspond to specific suction pressures.
- J7-1 = +5VDC return
- J7-2 = drain (shield connection = 0VDC)

If the optional Suction Transducer is not used on the YCAL0014 - YCAL0060, a Low Pressure switch will be used. Following are the microboard connections for the Low Pressure switch.

System 1 Low Pressure Switch

- J4-5 = +5VDC regulated supply to LP switch.
- J4-10 = input signal to the microboard. 0VDC = open switch / +5VDC = closed switch.
- J4-2 = drain (shield connection = 0VDC)

System 2 Low Pressure Switch

- J7-5 = +5VDC regulated supply to LP switch.
- J7-10 = input signal to the microboard. 0VDC = open switch / +5VDC = closed switch.
- J7-2 = drain (shield connection = 0VDC)

DIGITAL OUTPUTS

Refer to the unit wiring diagram and Fig. 14 and Table 40. The digital outputs are located on TB3, TB4, and TB5 of the microboard. **ALL OUTPUTS ARE 120VAC** with the exception of TB5-3 to TB5-4. TB5-3 to TB5-4 are the contacts that can be used for an evaporator pump start signal. The voltage applied to either of these terminals would be determined by field wiring.

Each output is controlled by the microprocessor by switching 120VAC to the respective output connection energizing contactors, evaporator heater, and solenoids according to the operating sequence.

120VAC is supplied to the microboard via connections at TB3-1, TB3-7, TB4-3, and TB4-7. Figure 14 illustrates the relay contact architecture on the microboard.

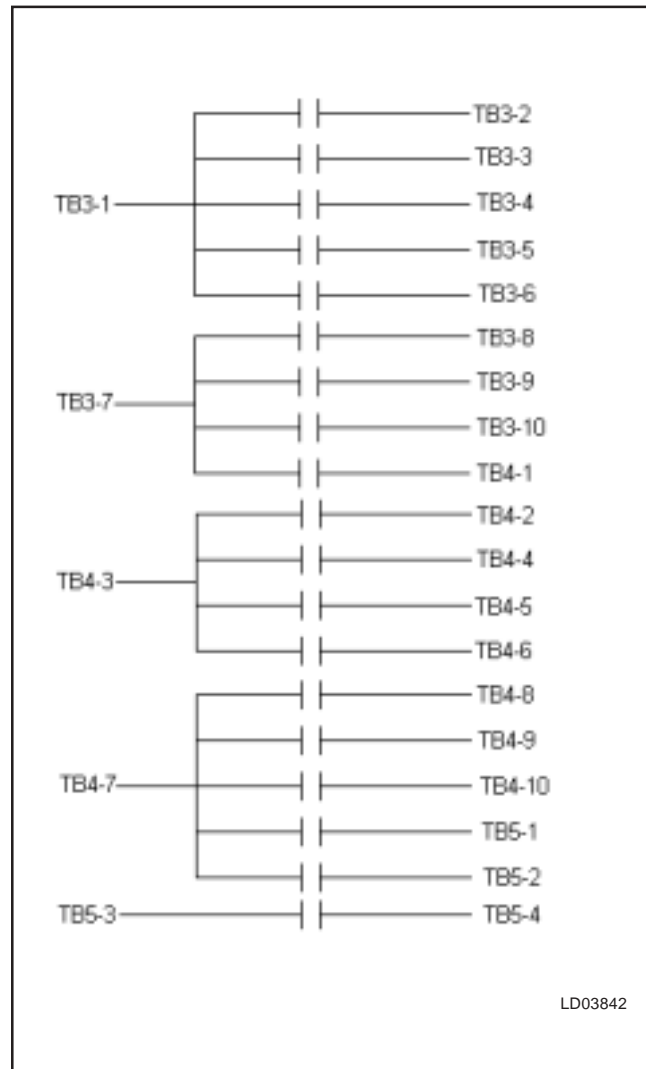

FIG. 14 – MICROBOARD RELAY CONTACT ARCHITECTURE

KEYPAD

The operator keypad is connected to the microboard by a ribbon cable, which is connected to J2 on the microboard.

The integrity of a specific “button” on the keypad can be verified by doing a continuity check across two specific points (or pins), that represent one of twelve “buttons” on the keypad.

Table 43 lists the key/pin assignments for the keypad. **Power to the microboard must be turned off, and the ribbon cable disconnected from the microboard prior to conducting the tests, or component damage may result.**

After the ribbon cable is disconnected from microboard, ohmmeter leads are connected to the pins representing the specific “button” to be tested. After connecting the meter leads, the “button” being checked is pressed and a reading of zero ohms should be observed. After releasing the “button,” the resistance value should be infinite (open circuit).

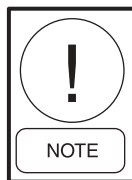

Pin 1 is usually identified by a stripe on the ribbon cable.

TABLE 40 – KEYPAD PIN ASSIGNMENT MATRIX

KEYPAD	PIN CONNECTIONS
STATUS	1 TO 5
OPER DATA	1 TO 7
PRINT	1 TO 6
HISTORY	1 TO 8
UP ARROW	2 TO 5
DOWN ARROW	2 TO 7
ENTER/ADV	2 TO 6
COOLING SETPOINTS	2 TO 8
SCHEDULE/ADVANCE DAY	3 TO 5
PROGRAM	3 TO 7
OPTIONS	3 TO 6
CLOCK	3 TO 8

OPTIONAL PRINTER INSTALLATION

The micro panel is capable of supplying a printout of chiller conditions or fault shutdown information at any given time. This allows operator and service personnel to obtain data and system status with the touch of the keypad. In addition to manual print selection, the micro panel will provide an automatic printout whenever a fault occurs. Detailed explanation of the print function is given under "Print Key" located in the Keypad and Display section.

YORK recommends the field tested WEIGH-TRONIX model 1220 printer (or former IMP 24). This is a compact low cost printer that is ideal for service work and data logging.

The WEIGH-TRONIX printer can be obtained by contacting WEIGH-TRONIX for purchase information at:

WEIGH-TRONIX
 2320 Airport Blvd.
 Santa Rosa, CA 95402
 Phone: 1-800-982-6622 or 1-707-527-5555
 (International Orders Only)

The part number for the printer that is packaged specifically for YORK is P/N 950915576. The cable to connect the printer can either be locally assembled from the parts listed, or ordered directly from WEIGH-TRONIX under part number 287-040018.

Parts

The following parts are required:

1. WEIGH-TRONIX model 1220 printer.
2. 2.25" (5.7cm) wide desk top calculator paper.
3. 25 ft. (7.62m) maximum length of Twisted Pair Shielded Cable (minimum 3 conductor), #18 AWG stranded, 300V minimum insulation.
4. One 25 pin Cannon connector and shell.
 Connector: Cannon P/N DB-25P or equivalent.
 Shell: Cannon P/N DB-C2-J9.

Assembly and Wiring

All components should be assembled and wired as shown in Figure 16. Strip the outside insulation back several inches and individual wires about 3/8" (9.5 mm) to connect the cable at the Microboard. Do not connect the shield at the printer-end of the cable.

Obtaining a Printout

A printout is obtained by pressing the "PRINT" key on the keypad and then pressing either the "OPER DATA" key or "HISTORY" key.

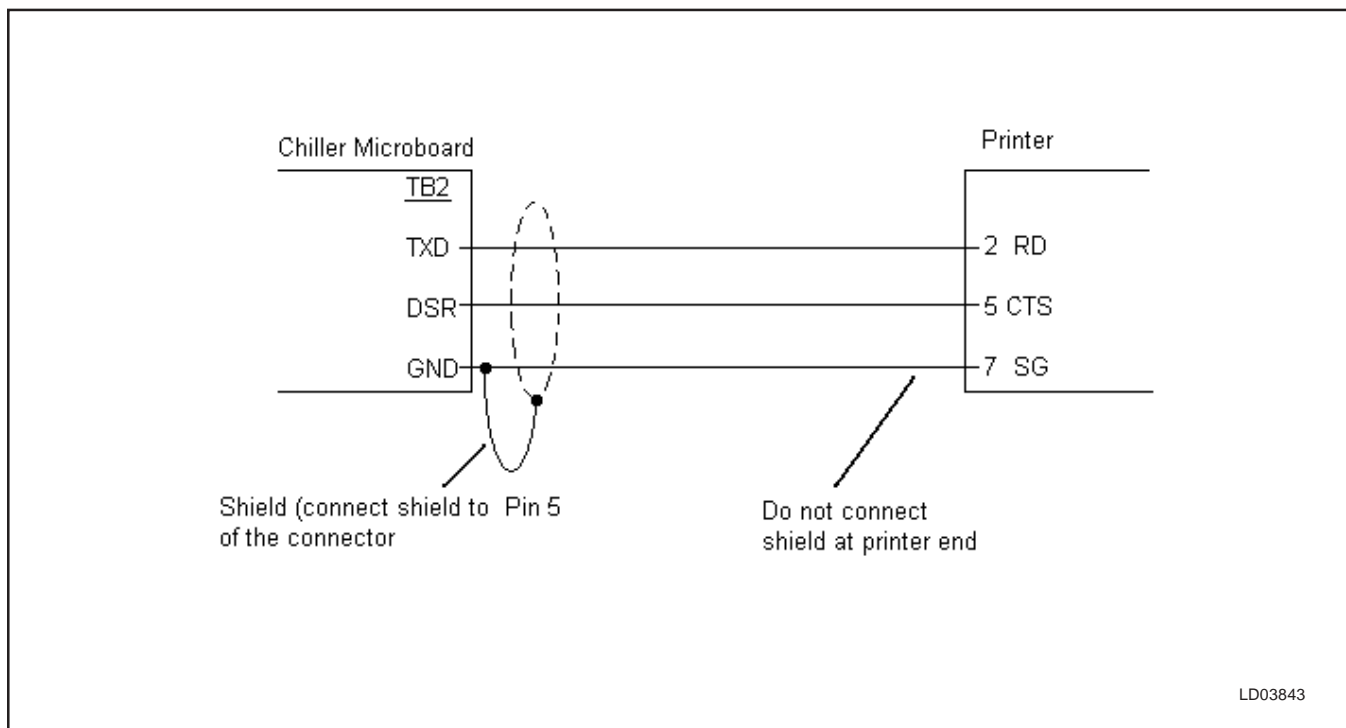

LD03843

FIG. 15 – PRINTER TO MICROBOARD ELECTRICAL CONNECTIONS

TROUBLESHOOTING

TABLE 41 – TROUBLESHOOTING

PROBLEM	CAUSE	SOLUTION
<p>No display on panel. Unit will not operate.</p>	<ol style="list-style-type: none"> 1. No 115VAC to 1T. 2. No 24VAC to Microboard 3. 1T defective, no 24VAC output. 4. Short in wire to temp. sensors or pressure transducers. 5. Defective Microboard or Display board. 	<ol style="list-style-type: none"> 1a. Check wiring and fuse 3FU b. Check wiring emergency stop contacts 5 to L of CTB2 Terminal Block. c. Replace 1T 2. Check wiring 1T to Microboard. 3. Replace 1T 4. Unplug connections at Microboard to isolate. 5. Replace Microboard. <p><i>NOTE: Contact YORK Service before Replacing circuit Boards!</i></p>
<p>“FLOW SWITCH/REM STOP NO RUN PERMISSIVE”</p>	<ol style="list-style-type: none"> 1. No chilled liquid flow. 2. Flow switch improperly installed. 3. Defective flow switch. 4. Remote cycling device open. 	<ol style="list-style-type: none"> 1. Check chilled liquid flow. 2. Check that the flow switch is installed according to manufacturer’s instructions. 3. Replace flow switch. 4. Check cycling devices connected to terminals 13 and 14 of the CTB1 Terminal Block.
<p>“LOW SUCTION PRESSURE” FAULT</p>	<ol style="list-style-type: none"> 1. Improper suction pressure cutouts adjustments. 2. Low refrigerant charge. 3. Fouled filter dryer. 	<ol style="list-style-type: none"> 1. Adjust per recommended settings. 2. Repair leak if necessary and add refrigerant. 3. Change dryer/core. <p style="text-align: right;"><i>CONT'D</i></p>

TROUBLESHOOTING (CONT'D)

PROBLEM	CAUSE	SOLUTION
<p>“LOW SUCTION PRESSURE” FAULT (CONT'D)</p>	<p>4. TXV defective.</p> <p>5. Reduced flow of chilled liquid through the cooler.</p> <p>6. Defective suction pressure transducer/low pressure switch or wiring.</p> <p>7. LLSV defective</p> <p>8. EEV Unit Setup in TXV mode.</p>	<p>4. Replace TXV.</p> <p>5. Check GPM (See “Limitations” in Installation section). Check operation of pump, clean pump strainer, purge chilled liquid system of air.</p> <p>6. Replace transducer/low pressure switch or faulty wiring. Refer to “Service” section for pressure/voltage formula.</p> <p>7. Replace LLSV</p> <p>8. Place in Service Mode & program for EEV.</p>
<p>“HIGH DISCHARGE PRESSURE” FAULT</p>	<p>1. Condenser fans not operating or operating backwards.</p> <p>2. Too much refrigerant.</p> <p>3. Air in refrigerant system.</p> <p>4. Defective discharge pressure transducer.</p>	<p>1. Check fan motor, fuses, and contactors. Assure fan blows air upward.</p> <p>2. Remove refrigerant.</p> <p>3. Evacuate and recharge system.</p> <p>4. Replace discharge pressure transducer. Refer to Service section for pressure/voltage formula.</p>
<p>“LOW LIQUID TEMP” FAULT</p>	<p>1. Improperly adjusted leaving chilled liquid temp. cutout (glycol only).</p> <p>2. Micro panel setpoint/range values improperly programmed.</p> <p>3. Chilled liquid flow too low.</p> <p>4. Defective LWT or RWT sensor. (assure the sensor is properly installed in the bottom of the well with a generous amount of heat conductive compound).</p>	<p>1. Re-program the leaving chilled liquid temp. cutout.</p> <p>2. Re-adjust setpoint/range.</p> <p>3. Increase chilled liquid flow – refer to Limitations in Installation section.</p> <p>4. Compare sensor against a known good temperature sensing device. Refer to Service section for temp./voltage table.</p> <p style="text-align: right;">CONT'D</p>

PROBLEM	CAUSE	SOLUTION
“MP / HPCO” FAULT	<ol style="list-style-type: none"> 1. Compressor internal motor protector (MP) open. 2. External overload tripped. 3. HPCO switch open 4. Defective HPCO switch 5. Defective CR relay 	<ol style="list-style-type: none"> 1. Verify refrigerant charge is not low. Verify superheat setting of °10 - 15°F (5.6° - 8.3°C). Verify correct compressor rotation. Verify compressor is not over loaded. 2. Determine cause and reset. 3. See “High Press. Disch.” Fault. 4. Replace HPCO switch 5. Replace relay
COMPRESSOR(S) WON'T START	<ol style="list-style-type: none"> 1. Demand not great enough. 2. Defective water temperature sensor. 3. Contactor/Overload failure 4. Compressor failure 	<ol style="list-style-type: none"> 1. No problem. Consult “Installation” Manual to aid in understanding compressor operation and capacity control. 2. Compare the display with a thermometer. Should be within +/- 2 degrees. Refer to Service section for RWT/ LWT temp./voltage table. 3. Replace defective part. 4. Diagnose cause of failure and replace.
LACK OF COOLING EFFECT	<ol style="list-style-type: none"> 1. Fouled evaporator surface. Low suction pressure will be observed. 2. Improper flow through the evaporator. 3. Low refrigerant charge. Low suction pressure will be observed. 	<ol style="list-style-type: none"> 1. Contact the local YORK service representative. 2. Reduce flow to within chiller design specs. See Limitations in Installation section. 3. Check subcooling and add charge as needed.

MAINTENANCE

It is the responsibility of the equipment owner to provide maintenance on the system.

IMPORTANT

If system failure occurs due to improper maintenance during the warranty period, YORK will not be liable for costs incurred to return the system to satisfactory operation. The following is intended only as a guide and covers only the chiller unit components. It does not cover other related system components which may or may not be furnished by YORK. System components should be maintained according to the individual manufacturer's recommendations as their operation will affect the operation of the chiller.

COMPRESSORS

Oil Level check

The oil level can only be tested when the compressor is running in stabilized conditions, to ensure that there is no liquid refrigerant in the lower shell of the compressor. When the compressor is running at stabilized conditions, the oil level must be between 1/4 and 3/4 in the oil sight glass. Note: at shutdown, the oil level can fall to the bottom limit of the oil sight glass. Use YORK "F" oil when adding oil.

Oil Analysis

The oil used in these compressors is pale yellow in color (mineral oil). If the oil color darkens or exhibits a change in color, this may be an indication of contaminants in the refrigerant system. If this occurs, an oil sample should be taken and analyzed. If contaminants are present, the system must be cleaned to prevent compressor failure.



Never use the scroll compressor to pump the refrigerant system down into a vacuum. Doing so will cause internal arcing of the compressor motor which will result in failure of compressor.

CONDENSER FAN MOTORS

Condenser fan motors are permanently lubricated and require no maintenance.

CONDENSER COILS

Dirt should not be allowed to accumulate on the condenser coil surfaces. Cleaning should be as often as necessary to keep coil clean.

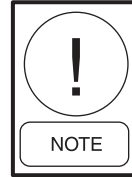

Exercise care when cleaning the coil so that the coil fins are not damaged.

OPERATING PARAMETERS

Regular checks of the system should be performed to ensure that operating temperatures and pressures are within limitations, and that the operating controls are set within proper limits. Refer to the Operation, Start-Up, and Installation sections of this manual.

ON-BOARD BATTERY BACK-UP

U17 is the Real Time Clock chip that maintains the date/time and stores customer programmed setpoints. Anytime the chiller is to be off (no power to the microboard) for an extended time (weeks/months), the clock should be turned off to conserve power of the on-board battery. To accomplish this, the J11 jumper on the microboard must be moved to the "CLKOFF" position while power is still supplied to the microboard.



The unit evaporator heater is 120VAC. Disconnecting 120VAC power from the unit, at or below freezing temperatures, can result in damage to the evaporator and unit as a result of the chilled liquid freezing.

OVERALL UNIT INSPECTION

In addition to the checks listed on this page, periodic overall inspections of the unit should be accomplished to ensure proper equipment operation. Items such as loose hardware, component operation, refrigerant leaks, unusual noises, etc. should be investigated and corrected immediately.

ISN CONTROL

RECEIVED DATA (CONTROL DATA)

The Middle Market receives 8 data values from the ISN. The first 4 are analog values and the last 4 are digital values. These 8 data values are used as control parameters when in REMOTE mode. When the unit is in LOCAL mode, these 8 values are ignored. If the unit receives no valid ISN transmission for 5 minutes it will revert back to all local control values. Table 45 lists the 5 control parameters. These values are found under feature 54 on the ISN.

TABLE 42 – ISN RECEIVED DATA

ISN PAGE	CONTROL DATA
P03	SETPOINT 99 = AUTO
P04	LOAD LIMIT STAGE (0,1, 2)
P05	–
P06	–
P07	START/STOP COMMAND (0 = STOP, 1 = RUN)
P08	—
P09	—
P10	HISTORY BUFFER REQUEST (0 = CURRENT DATA, 1 = LAST HISTORY DATA)

TRANSMITTED DATA

After receiving a valid transmission from the ISN, the unit will transmit either operational data or history buffer data depending on the “History Buffer Request” on ISN PAGE 10. Data must be transmitted for every ISN page under feature 54. If there is no value to be sent to a particular page, a zero will be sent. Tables 43 - 44 show the data values and page listings for this unit.

TABLE 43 – ISN TRANSMITTED DATA

ISN PG.	TYPE	DATA
P11	Analog	Leaving Chilled Liquid Temp
P12	Analog	Return Chilled Liquid temp
P13	Analog	–
P14	Analog	–
P15	Analog	SYS 1 Suction Temp (EEV Only)
P16	Analog	Ambient Air Temperature
P17	Analog	SYS 1 Suction Superheat (EEV Only)
P18	Analog	SYS 1 Run Time (seconds)
P19	Analog	SYS 1 Suction Pressure
P20	Analog	SYS 1 Discharge Pressure
P21	Analog	SYS 1 Cooler Inlet Refrigerant Temp (R-407c Only)
P22	Analog	–
P23	Analog	SYS 1 EEV Output % (EEV Only)
P24	Analog	SYS 1 Anti-Recycle Timer
P25	Analog	Anti-Coincidence Timer
P26	Analog	SYS 2 Suction Temp. (EEV Only)
P27	Analog	SYS 2 Run Time (seconds)
P28	Analog	SYS 2 Suction Pressure
P29	Analog	SYS 2 Discharge Pressure
P30	Analog	SYS 2 Cooler Inlet Refrigerant Temp (R-407c Only)
P31	Analog	–
P32	Analog	SYS 2 Suction Superheat (EEV Only)
P33	Analog	SYS 2 Anti-Recycle Timer
P34	Analog	SYS 2 EEV Output % (EEV Only)
P35	Analog	Number of Compressors
P36	Digital	SYS 1 Alarm
P37	Digital	SYS 2 Alarm
P38	Digital	Evaporator Heater Status
P39	Digital	Evaporator Pump Status
P40	Digital	SYS 1 Comp 1 Run
P41	Digital	SYS 2 Comp 1 Run
P42	Digital	SYS 1 Liquid Line Solenoid Valve or EEV Pilot Solenoid
P43	Digital	SYS 1 Hot Gas Bypass Valve
P44	Digital	SYS 1 Comp 2 Run
P45	Digital	SYS 2 Comp 2 Run
P46	Digital	SYS 2 Liquid Line Solenoid Valve or EEV Pilot Solenoid
P47	Digital	Lead System (0=SYS 1, 1=SYS 2)
P48	Digital	SYS 1 Comp 3 Run

TABLE 43 – ISN TRANSMITTED DATA (CONT'D)

ISN PG.	TYPE	DATA
P49	Digital	SYS 2 Comp 3 Run
P50	Digital	Chilled Liq. Type (0=Water, 1=Glycol)
P51	Digital	Ambient Control Mode (0=Std Ambient, 1=Low Ambient)
P52	Digital	Local/Remote Control Mode (0=Local, 1=Remote)
P53	Digital	Units (0=Imperial, 1=SI)
P54	Digital	Lead/Lag Control Mode (0=Manual, 1=Automatic)
P55	Digital	—
P56	Coded	* SYS 1 Operational Code
P57	Coded	* SYS 1 Fault Code
P58	Coded	* SYS 2 Operational Code
P59	Coded	* SYS 2 Fault Code
P60	Coded	—
P61	Coded	SYS 1 Condenser Fan Stage
P62	Coded	—
P63	Coded	SYS 2 Condenser Fan Stage
P64	Coded	—
P65	Coded	Unit Control Mode (0=Leaving Water, 1=Return Water, 2=Discharge Air, 3=Suction Press., 4=Cooling, 5=Heating)

ISN PG.	TYPE	DATA
P66	Analog	Anti-Recycle Time (Programmed)
P67	Analog	Leaving Chilled Liquid Temp Cutout
P68	Analog	Low Ambient Temp Cutout
P69	Analog	—
P70	Analog	Low Suction Pressure Cutout
P71	Analog	High Discharge Pressure Cutout
P72	Analog	Setpoint
P73	Analog	Cooling Range
P74	Analog	—
P75	Analog	—
P76	Analog	SYS 1 Discharge Temp (EEV Only - Optional)
P77	Analog	SYS 1 Discharge Superheat (EEV Only - Optional)
P78	Analog	SYS 2 Discharge Temp (EEV Only - Optional)
P79	Analog	SYS 2 Discharge Superheat (EEV Only - Optional)
P80	Digital	—
P81	Digital	—
P82	Digital	—
P83	Digital	—
P84	Digital	—

TABLE 44 – ISN OPERATIONAL AND FAULT CODES

P56/58	OPERATIONAL CODE	P57/59	FAULT CODE
0	NO ABNORMAL CONDITION	0	NO FAULT
1	UNIT SWITCH OFF	1	VAC UNDER VOLTAGE
2	SYSTEM SWITCH OFF	2	LOW AMBIENT TEMPERATURE
3	LOCK-OUT	3	HIGH AMBIENT TEMPERATURE
4	UNIT FAULT	4	LOW LEAVING CHILLED LIQUID TEMP
5	SYSTEM FAULT	5	HIGH DISCHARGE PRESSURE
6	REMOTE SHUTDOWN	6	HIGH DIFFERENTIAL OIL PRESSURE
7	DAILY SCHEDULE SHUTDOWN	7	LOW SUCTION PRESSURE
8	NO RUN PERMISSIVE	8	HIGH MOTOR CURRENT
9	NO COOL LOAD	9	LLSV NOT ON
10	ANTI-COINCIDENCE TIMER ACTIVE	10	LOW BATTERY WARNING
11	ANTI-RECYCLE TIMER ACTIVE	11	HIGH OIL TEMPERATURE
12	MANUAL OVERRIDE	12	HIGH DISCHARGE TEMPERATURE
13	SUCTION LIMITING	13	IMPROPER PHASE ROTATION
14	DISCHARGE LIMITING	14	LOW MOTOR CURRENT /MP / HPCO
15	CURRENT LIMITING	15	MOTOR CURRENT UNBALANCED
16	LOAD LIMITING	16	LOW DIFFERENTIAL OIL PRESSURE
17	COMPRESSOR(S) RUNNING	17	GROUND FAULT
18	HEAT PUMP LOAD LIMITING	18	MP /HPCO
		19	LOW EVAPORATOR TEMPERATURE
		20	INCORRECT REFRIGERANT PROGRAMMED
		21	POWER FAILURE, MANUAL RESET REQUIRED
		22	UNIT MOTOR CURRENT
		23	LOW SUPERHEAT
		24	SENSOR FAIL

* The operational and fault codes sent to pages 56 through 59 are defined in Table 47. Note that this table of fault and operational codes is for all DX products. The codes that are grayed out are not used on all units.

ELEMENTARY DIAGRAM YCAL0014E_ - YCAL0020E_

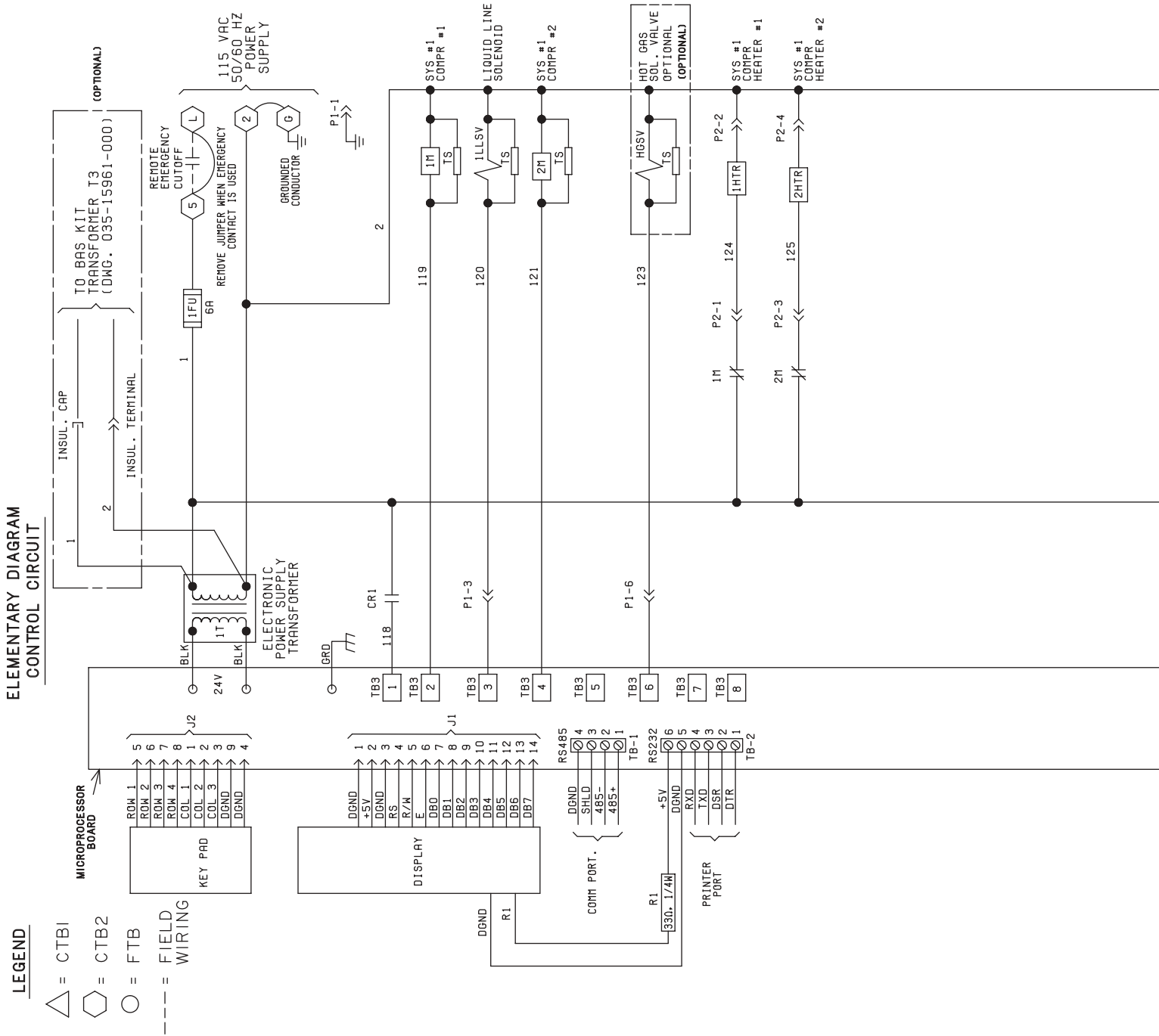

FIG. 16 – ELEMENTARY DIAGRAM, CONTROL CIRCUIT – YCAL0014E_ - YCAL0020E_

ELEMENTARY DIAGRAM YCAL0014E_ – YCAL0020E_

ELEMENTARY DIAGRAM

POWER CIRCUIT

SYSTEM #1
FUSED DISCONNECT SW. OR
CIRCUIT BREAKER (BY OTHERS)
SEE NOTE BELOW

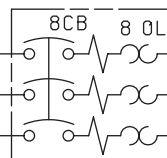
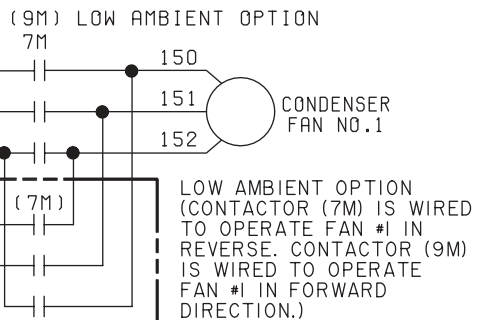
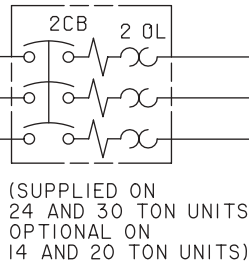
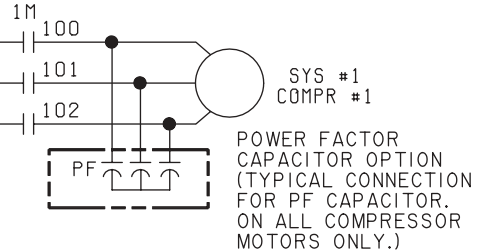
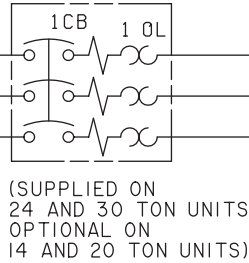
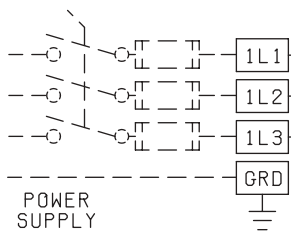

NOTE:
HACR CIRCUIT BREAKER
MUST BE USED WITH
14 & 20 TON UNITS UNLESS
OPTIONAL OVERLOADS
ARE INSTALLED

TRANSFORMER KIT
(OPTIONAL)
INCLUDES PRIMARY FUSES

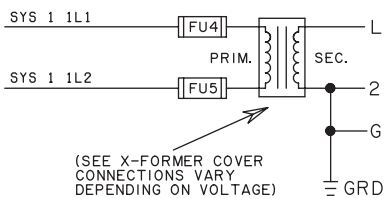

SINGLE POINT CIRCUIT
BREAKER (OPTIONAL)

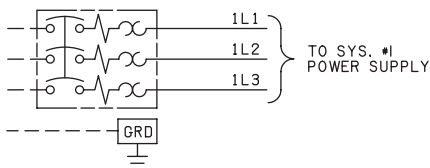

SINGLE POINT MOLDED CASE
NON-FUSED DISCONNECT SWITCH
(OPTIONAL)

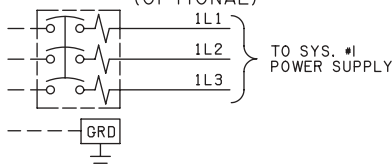

LD07831

FIG. 17 – ELEMENTARY DIAGRAM, POWER CIRCUIT – YCAL0014E_ - YCAL0020E_

This page intentionally left blank.

ELEMENTARY DIAGRAM YCAL0040E_ AND YCAL0060E_

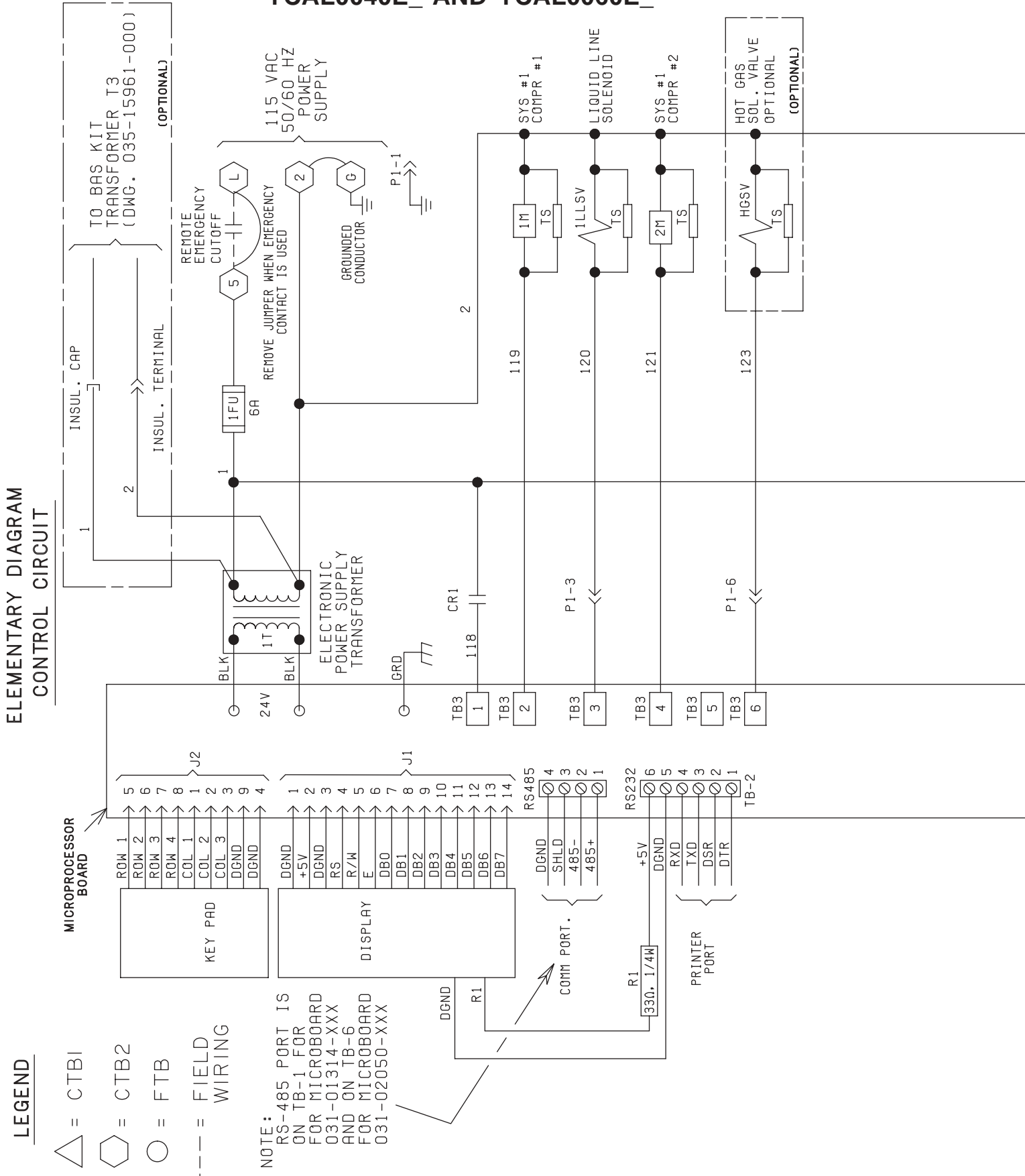
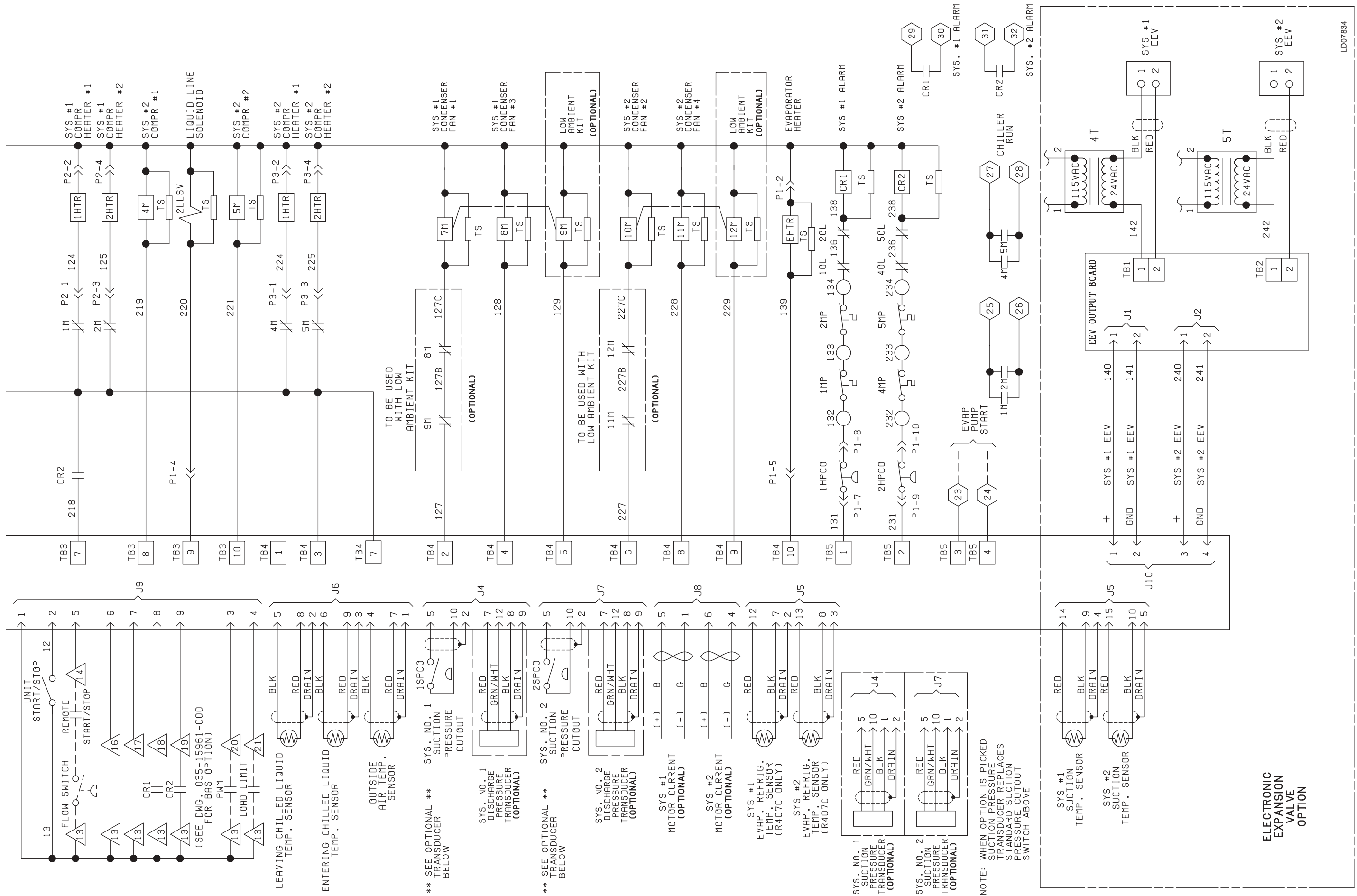

FIG. 18 - ELEMENTARY DIAGRAM, CONTROL CIRCUIT - YCAL0040E_ - YCAL0060E_



LD07834

ELEMENTARY DIAGRAM YCAL0040E_ AND YCAL0060E_

ELEMENTARY DIAGRAM

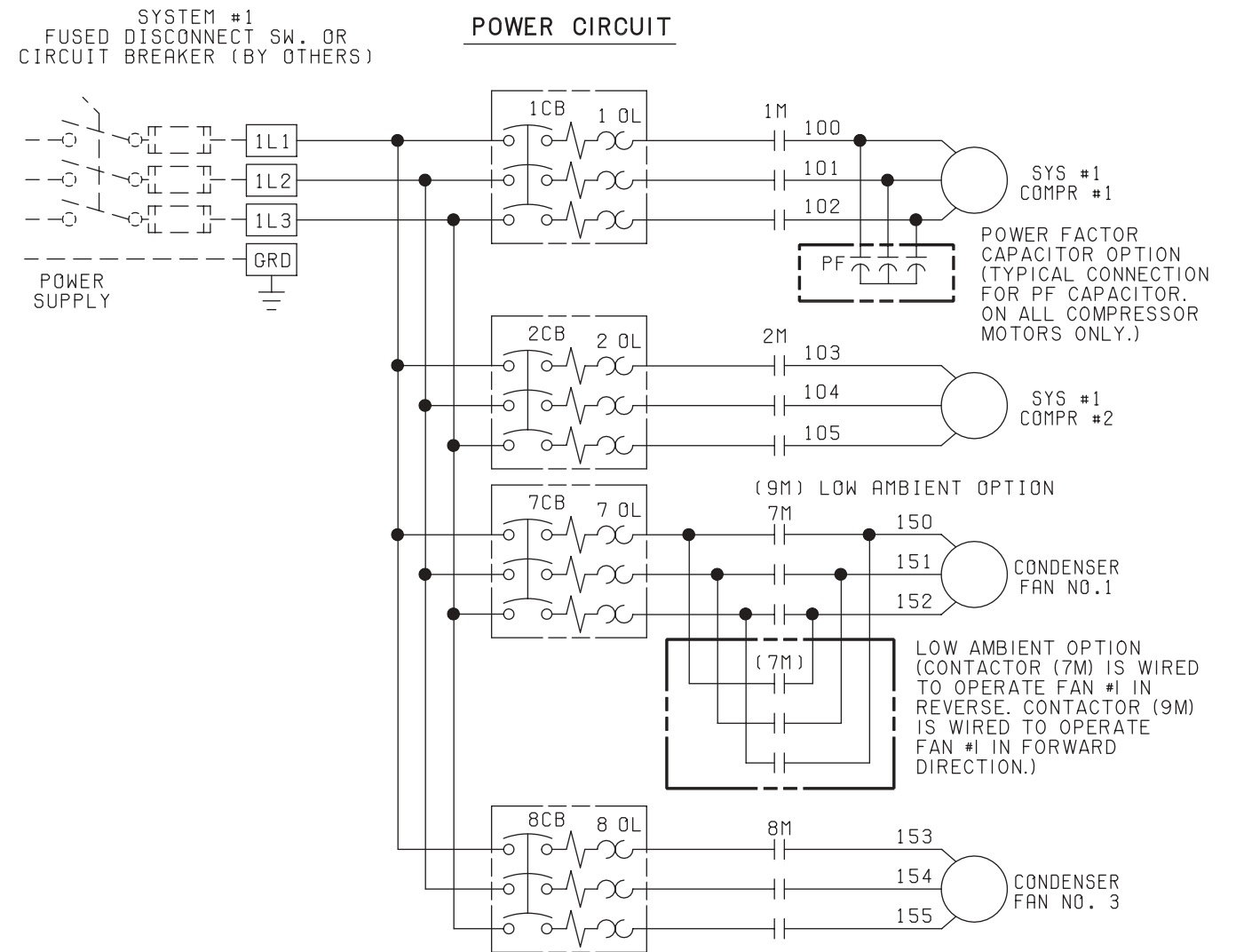

This page intentionally left blank.

4

LD07833A

FIG. 19 – ELEMENTARY DIAGRAM, POWER CIRCUIT – YCAL0040E_ - YCAL0060E_

ELEMENTARY DIAGRAM YCAL0040E_ AND YCAL0060E_

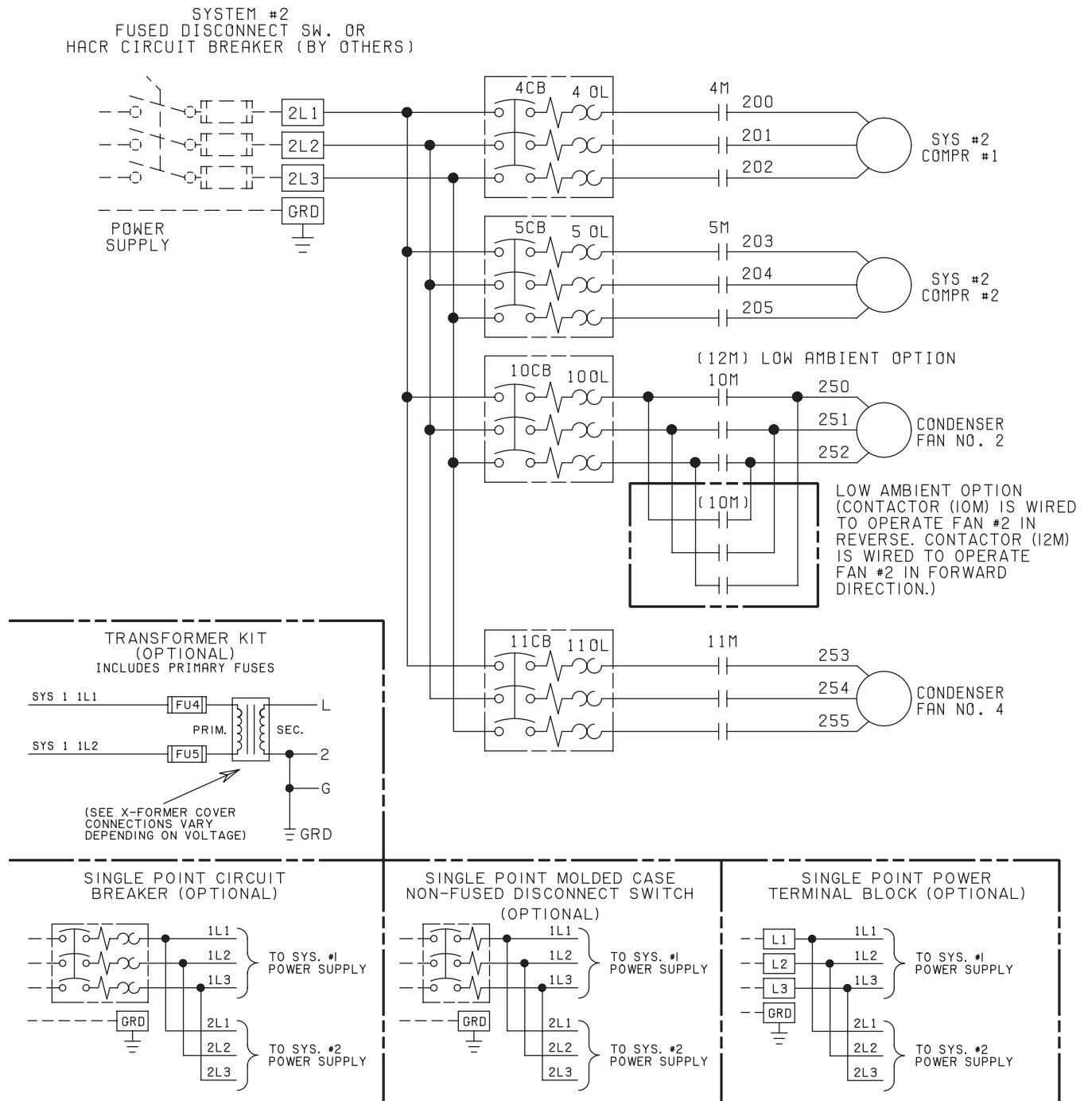

4

FIG. 19 – ELEMENTARY DIAGRAM, POWER CIRCUIT – YCAL0040E_ - YCAL0060E_ (CONT'D)

ELEMENTARY DIAGRAM YCAL0064E_ - YCAL0080E_

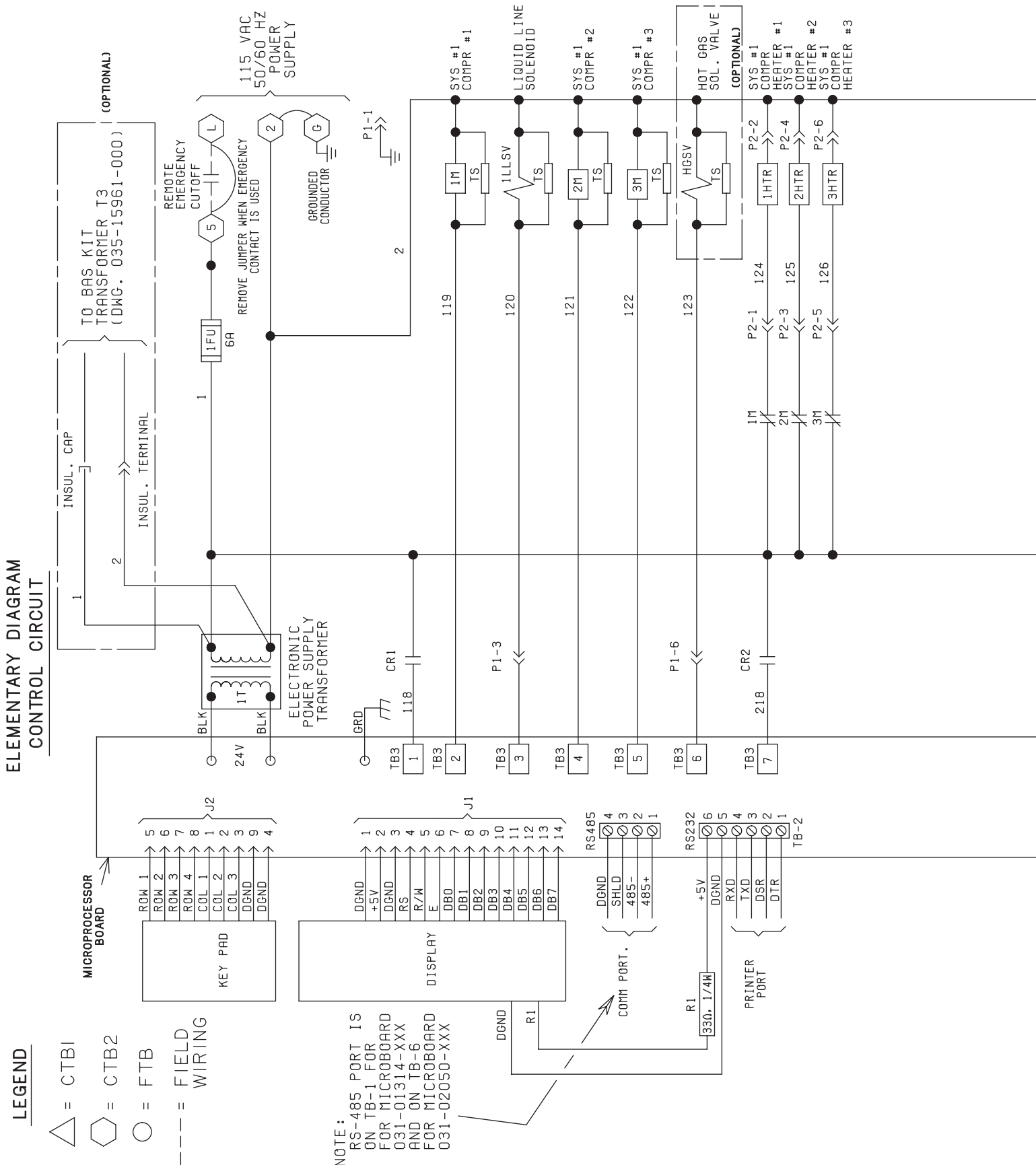

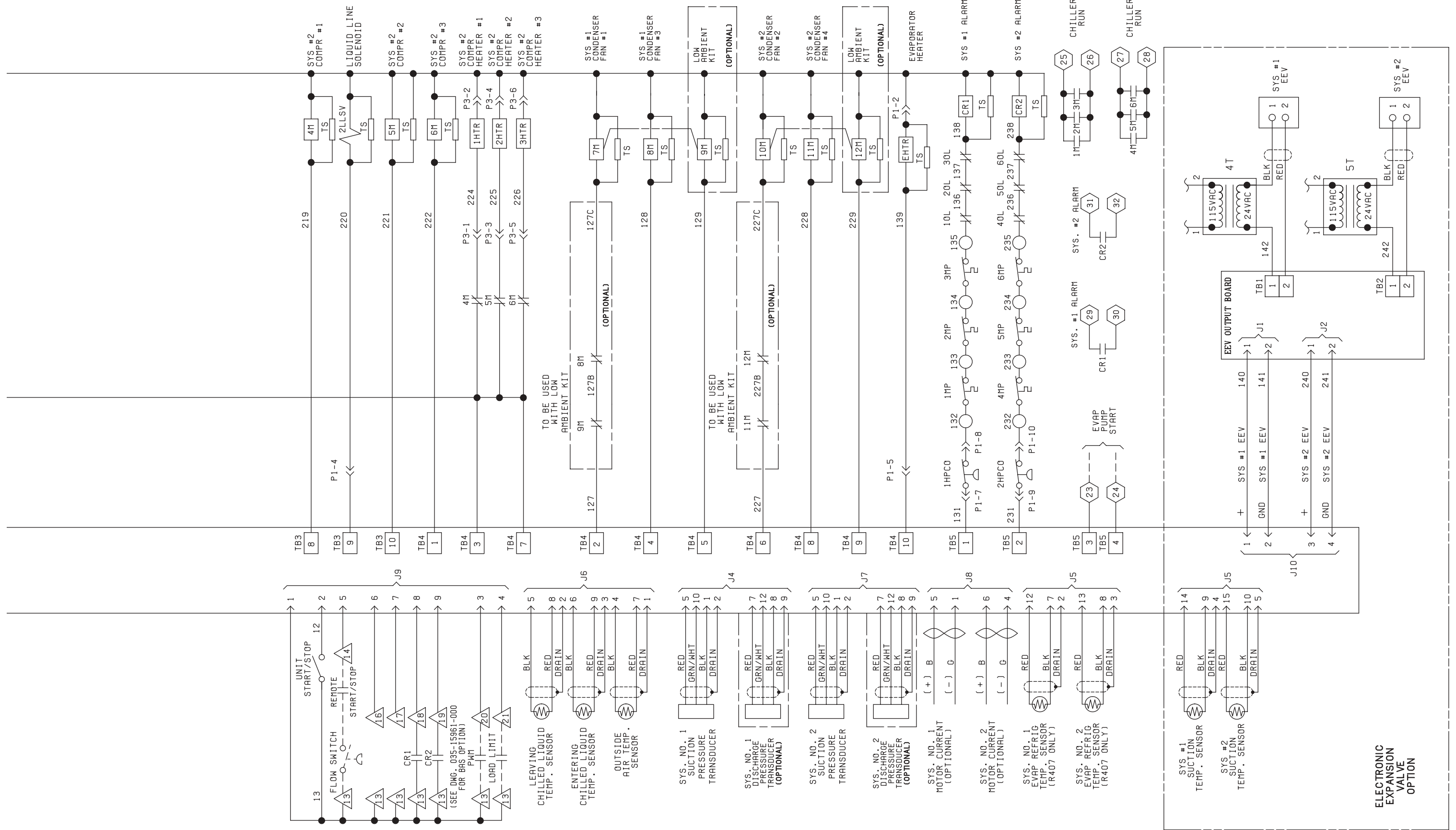

**ELEMENTARY DIAGRAM
YCAL0064E_ - YCAL0080E_**

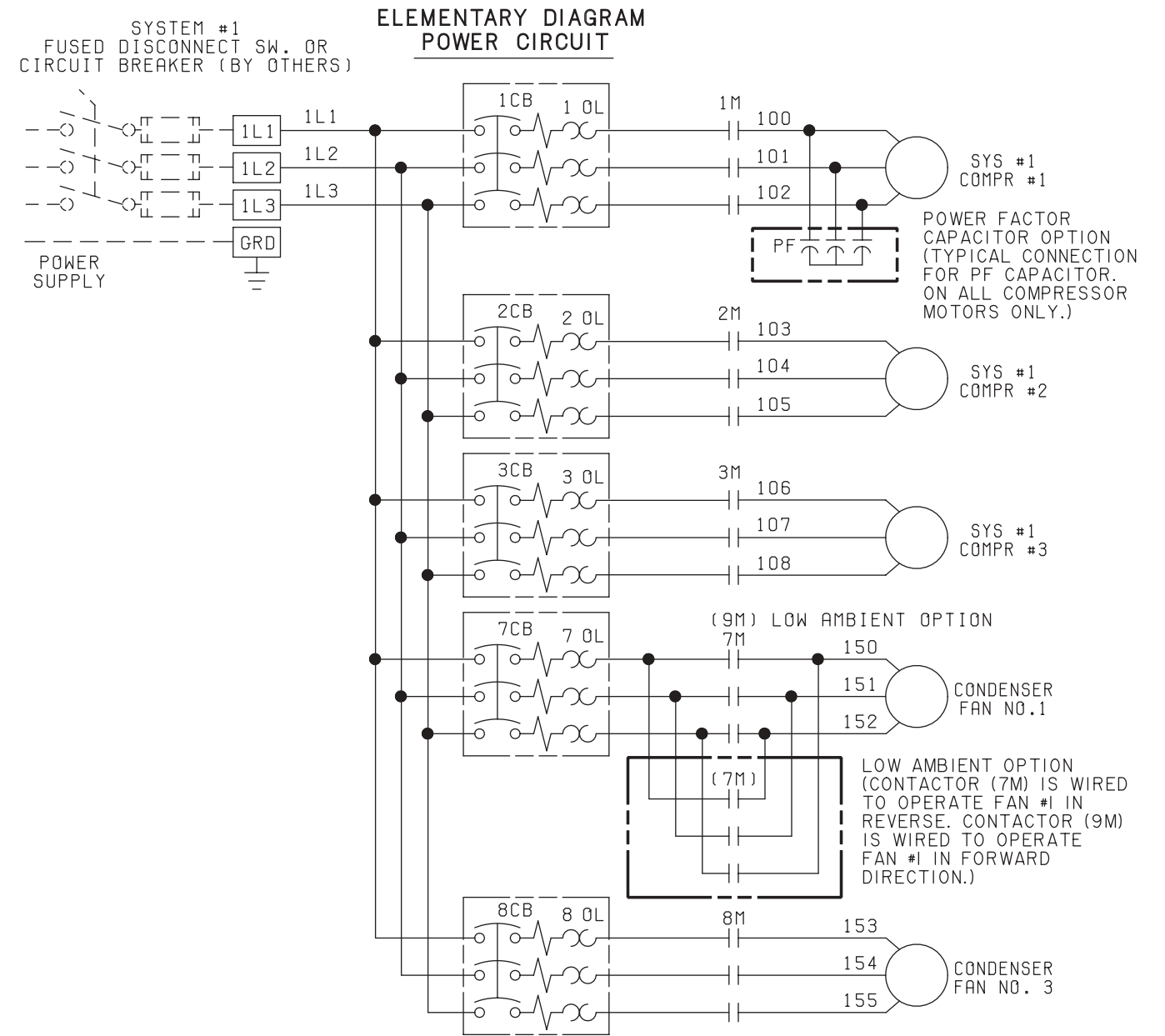

This page intentionally left blank.

LD07835A

FIG. 21 - ELEMENTARY DIAGRAM, POWER CIRCUIT - YCAL0064E_ - YCAL0080E_

ELEMENTARY DIAGRAM YCAL0064E_ - YCAL0080E_

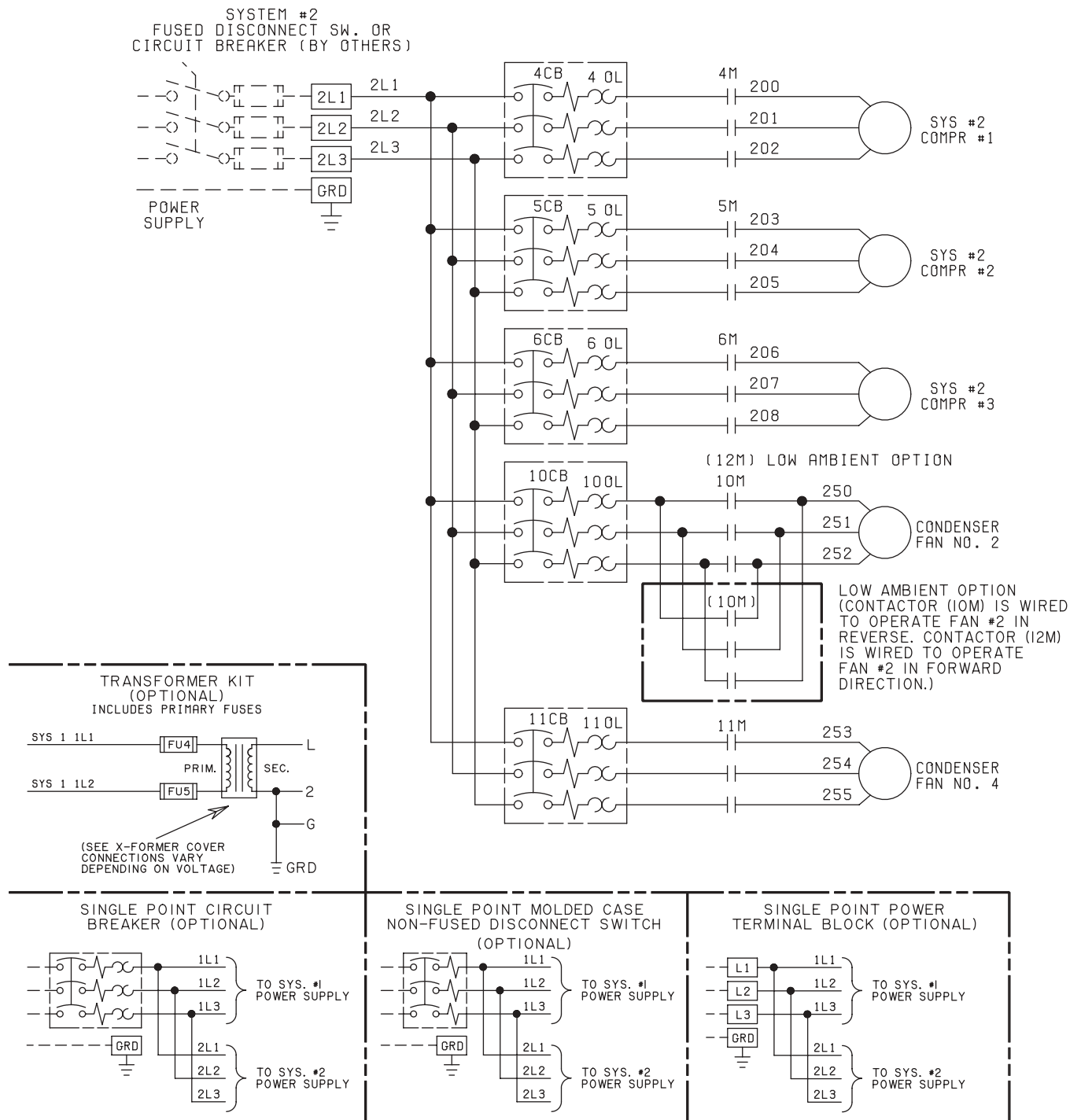

4

FIG. 21 - ELEMENTARY DIAGRAM, POWER CIRCUIT - YCAL0064E_ - YCAL0080E_ (CONT'D)

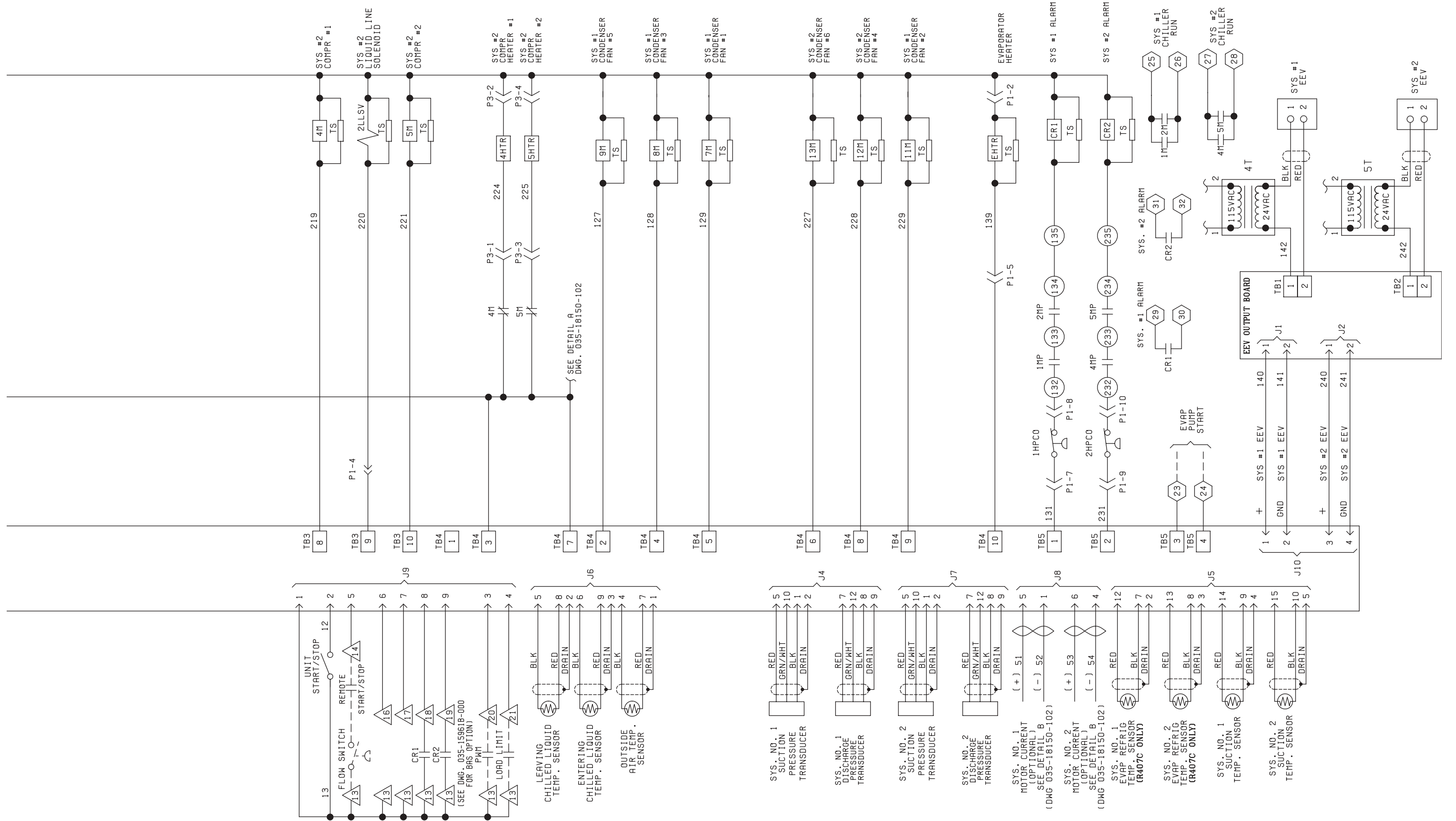

**ELEMENTARY DIAGRAM
YCAL0090E_ - YCAL0094E_**

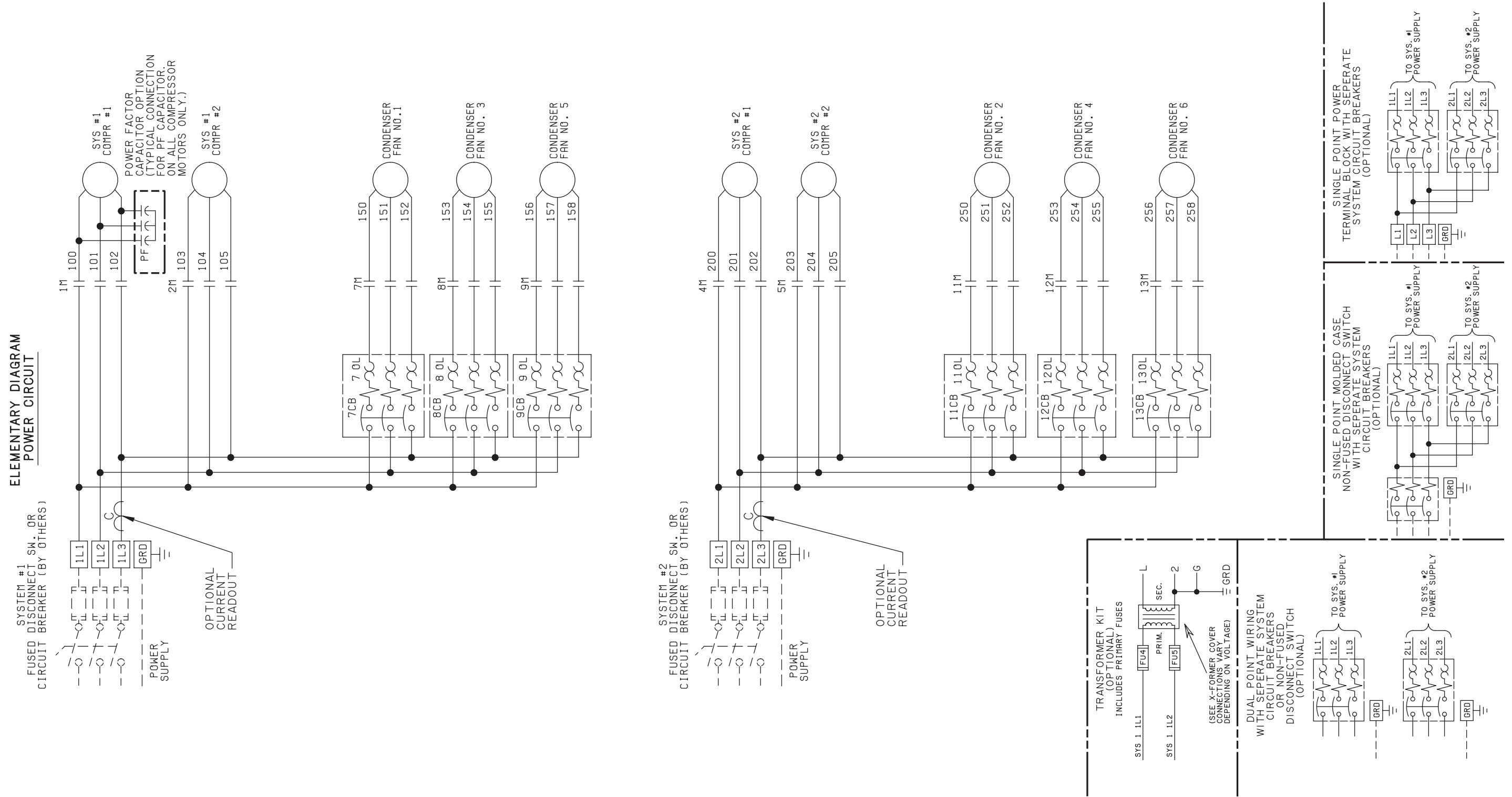

FIG. 23 - ELEMENTARY DIAGRAM, POWER CIRCUIT - YCAL0090E_ - YCAL0094E_

ELEMENTARY DIAGRAM YCAL0090E_ – YCAL0094E_

ELEMENTARY DIAGRAM
MIDDLE MARKET HIGH PERFORMANCE
STANDARD AND REMOTE EVAPORATOR UNITS

035-18150-102
REV. B

NOTES:

- FIELD WIRING TO BE IN ACCORDANCE WITH THE CURRENT EDITION OF THE NATIONAL ELECTRICAL CODE AS WELL AS ALL OTHER APPLICABLE CODES AND SPECIFICATIONS.
- CONTACTS MUST BE SUITABLE FOR SWITCHING 24VDC. (GOLD CONTACTS RECOMMENDED). WIRING SHALL NOT BE RUN IN THE SAME CONDUIT WITH ANY LINE VOLTAGE (CLASS I) WIRING.
- TO CYCLE UNIT ON AND OFF AUTOMATICALLY WITH CONTACT SHOWN, INSTALL A CYCLING DEVICE IN SERIES WITH THE FLOW SWITCH. SEE NOTE 2 FOR CONTACT RATING AND WIRING SPECIFICATIONS.
- TO STOP UNIT (EMERGENCY STOP) WITH CONTACTS OTHER THAN THOSE SHOWN, INSTALL THE STOP CONTACT BETWEEN TERMINALS S AND I. IF A STOP DEVICE IS NOT INSTALLED, A JUMPER MUST BE CONNECTED BETWEEN TERMINALS S AND I. DEVICE MUST HAVE A MINIMUM CONTACT RATING OF 6A AT 115VOLTS A.C.
- CONTACTS ARE RATED AT 115V, 100VA, RESISTIVE LOAD ONLY, AND MUST BE SUPPRESSED AT LOAD BY USER.
- SEE INSTALLATION, OPERATION AND MAINTENANCE MANUAL WHEN OPTIONAL EQUIPMENT IS USED.
- OPTIONAL CURRENT READOUT, 5V = 225A FOR 380, 400, 460 & 575V, 5V = 450A FOR 200 & 230V CHILLERS
- 1MP THRU 6MP ARE CONTAINED IN THEIR RESPECTIVE COMPRESSOR JUNCTION BOXES.

LEGEND

- TS TRANSIENT VOLTAGE SUPPRESSION
- ◻ TERMINAL BLOCK FOR CUSTOMER CONNECTIONS
- △ TERMINAL BLOCK FOR CUSTOMER LOW VOLTAGE (CLASS 2) CONNECTIONS. SEE NOTE 2.
- ◻ TERMINAL BLOCK FOR YORK CONNECTIONS ONLY
- WIRING AND COMPONENTS BY YORK
- - - - - OPTIONAL EQUIPMENT
- - - - - WIRING AND/OR COMPONENTS BY OTHERS

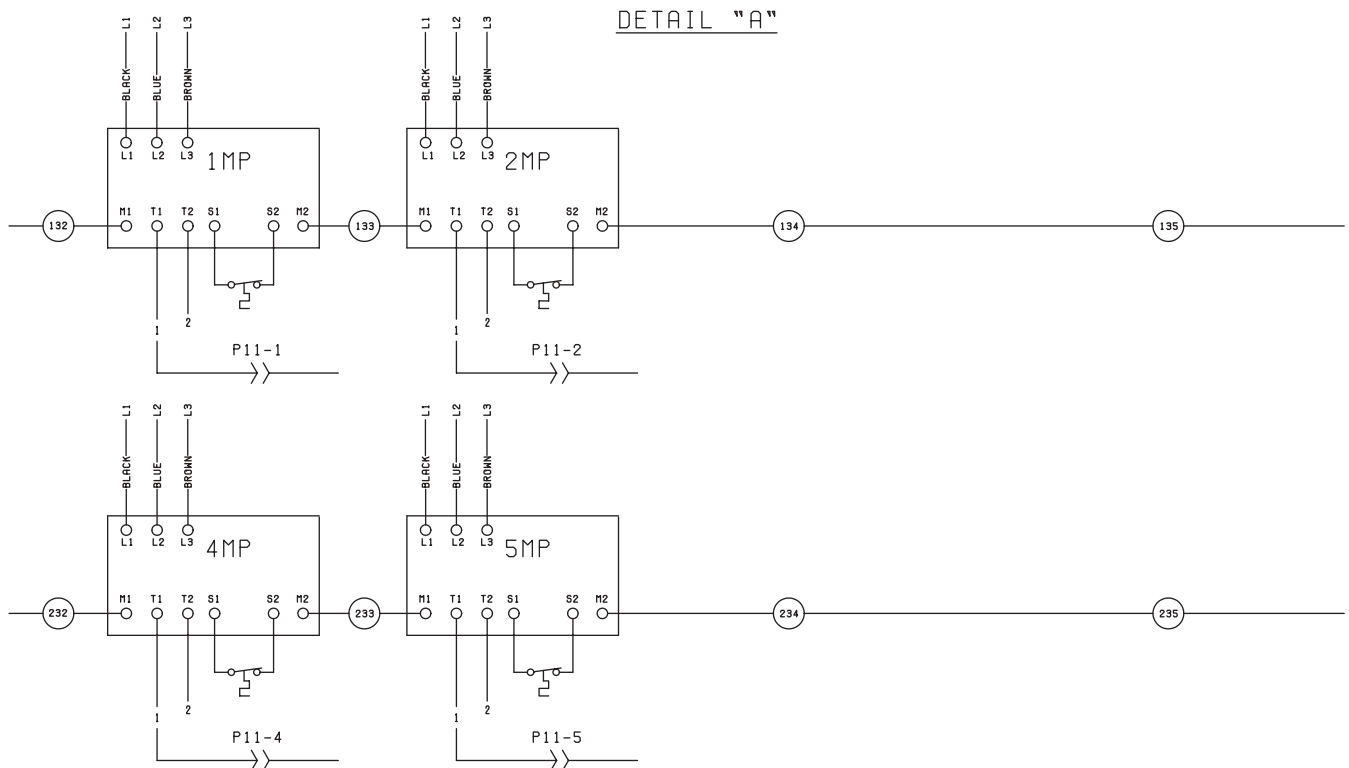

DETAIL "B"

OPTIONAL MOTOR CURRENT READOUT

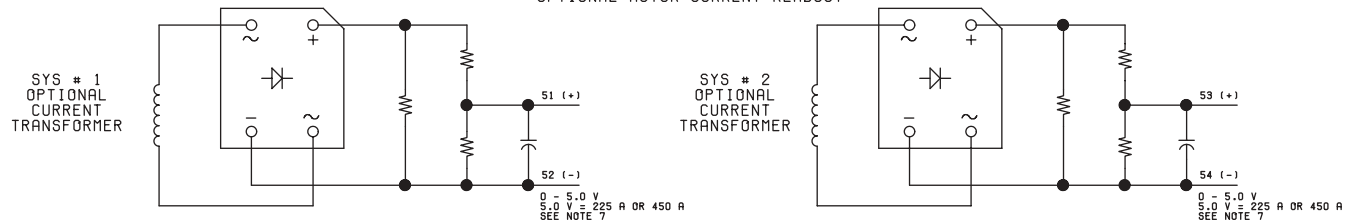

FIG. 24 – ELEMENTARY DIAGRAM, DETAIL "A" & DETAIL "B" – YCAL0090E_ - YCAL0094E_

ELEMENTARY DIAGRAM YCAL0090E_ - YCAL0094E_

CONNECTION DIAGRAM MIDDLE MARKET HIGH PERFORMANCE

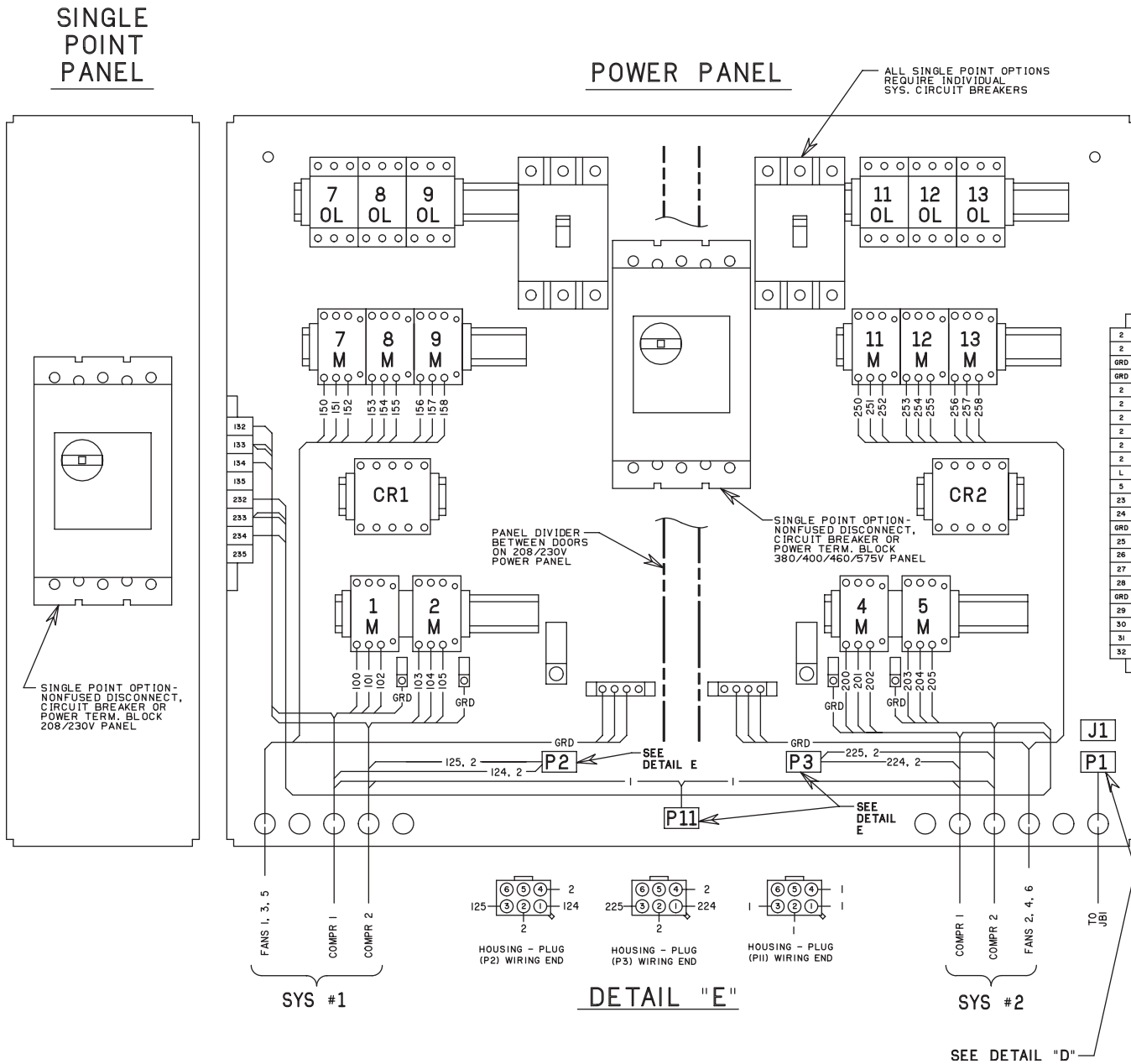

FIG. 25 - CONNECTION DIAGRAM - YCAL0090E_ - YCAL0094E_

MICRO PANEL

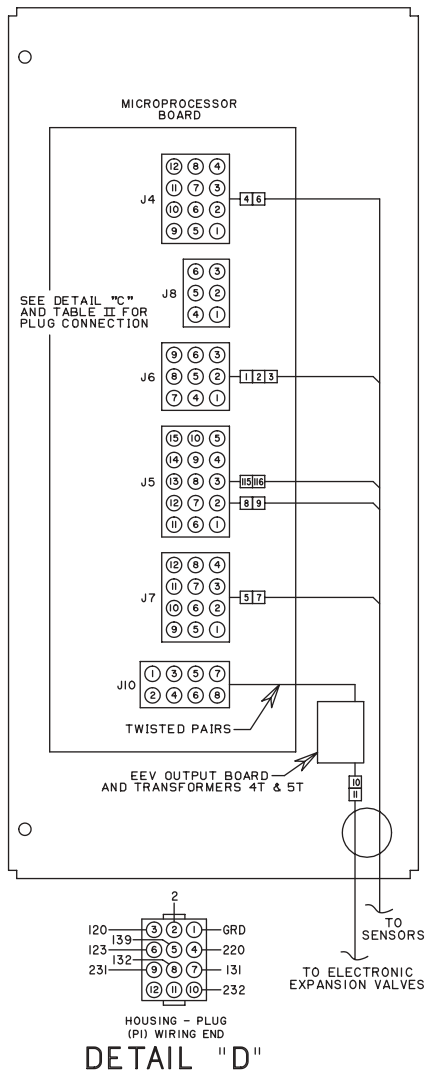
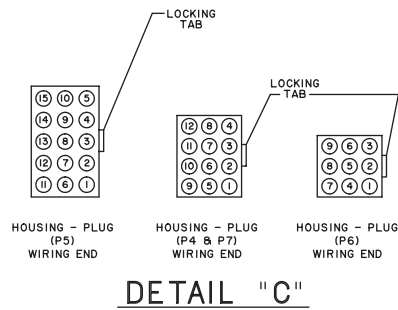
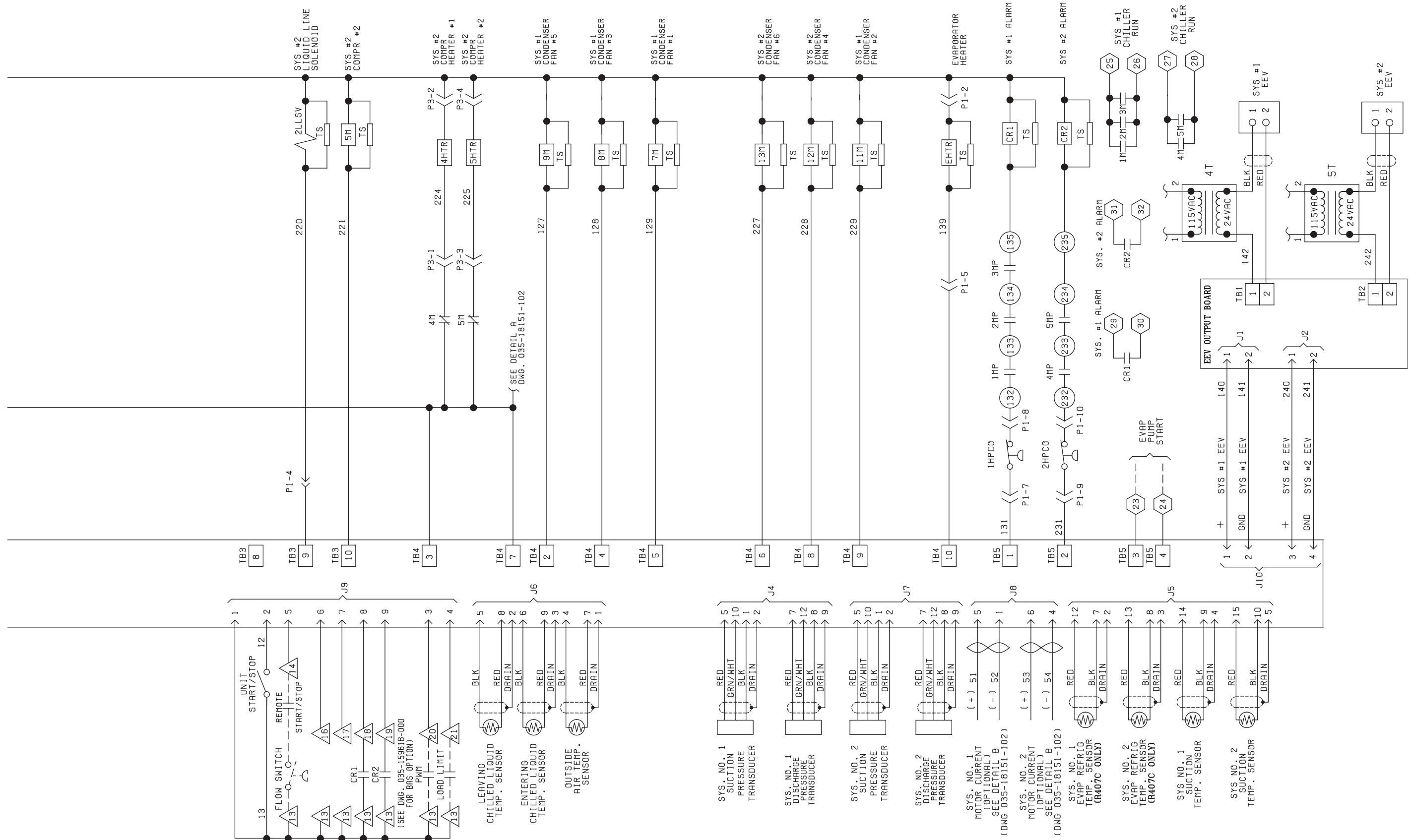

TABLE II

BOARD PLUG NO.	CABLE CODE	WIRE COLOR	PLUG PIN NO.	FUNCTION	LEGEND
MICRO P4	4	RED	5	SYS #1 SUCTION PRESSURE	ISPT
		WHT	10		
		BLK	1		
		DRAIN	2		
MICRO P4	6	RED	7	SYS #1 DISCHARGE PRESSURE	IDPT
		WHT	12		
		BLK	8		
		DRAIN	9		
MICRO P6	1	BLK	5	LEAVING WATER TEMP	LWT
		RED	8		
		DRAIN	2		
	3	BLK	6	ENTERING WATER TEMP	EWT
		RED	9		
		DRAIN	3		
2	BLK	4	OUTSIDE AIR TEMP.	OAT	
	RED	7			
	DRAIN	1			
MICRO P7	5	RED	5	SYS #2 SUCTION PRESSURE	2SPT
		WHT	10		
		BLK	1		
		DRAIN	2		
MICRO P7	7	RED	7	SYS #2 DISCHARGE PRESSURE	2DPT
		WHT	12		
		BLK	8		
		DRAIN	9		
MICRO P5	STANDARD 407C I15	RED	12	SYS #1 LIO. TEMP. SENSOR	1LTS
		BLK	7		
		DRAIN	2		
	STANDARD 407C I16	RED	13	SYS #2 LIO. TEMP. SENSOR	2LTS
		BLK	8		
		DRAIN	3		
	8	RED	14	SYS #1 SUCTION TEMP. SENSOR	1STS
		BLK	9		
		DRAIN	4		
	9	RED	15	SYS #2 SUCTION TEMP. SENSOR	2STS
		BLK	10		
		DRAIN	5		
EEV OUTPUT BOARD AND TRANSFORMER 4T, 5T	10	BLK (TRANS)	4T	SYS #1 EEV OUTPUT	IEEV
		RED	EEV OUTPUT BOARD TR-2		
		BLK (TRANS)	5T		
EEV OUTPUT BOARD AND TRANSFORMER 4T, 5T	11	RED	EEV OUTPUT BOARD TR-2	SYS #2 EEV OUTPUT	2EEV
		RED	EEV OUTPUT BOARD TR-2		



LD07840



ELEMENTARY DIAGRAM YCAL1040E_

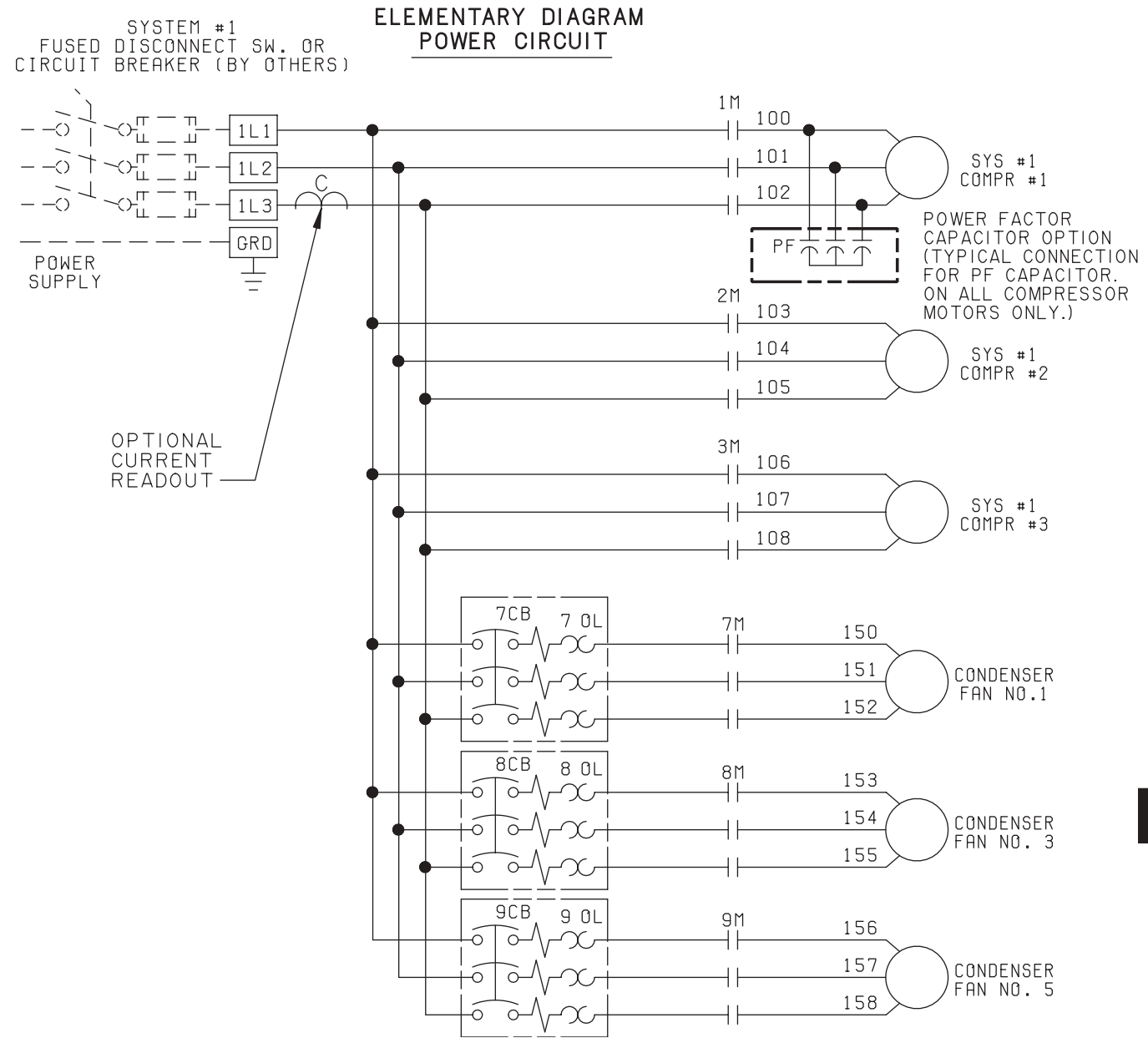

4

ELEMENTARY DIAGRAM YCAL1040E_

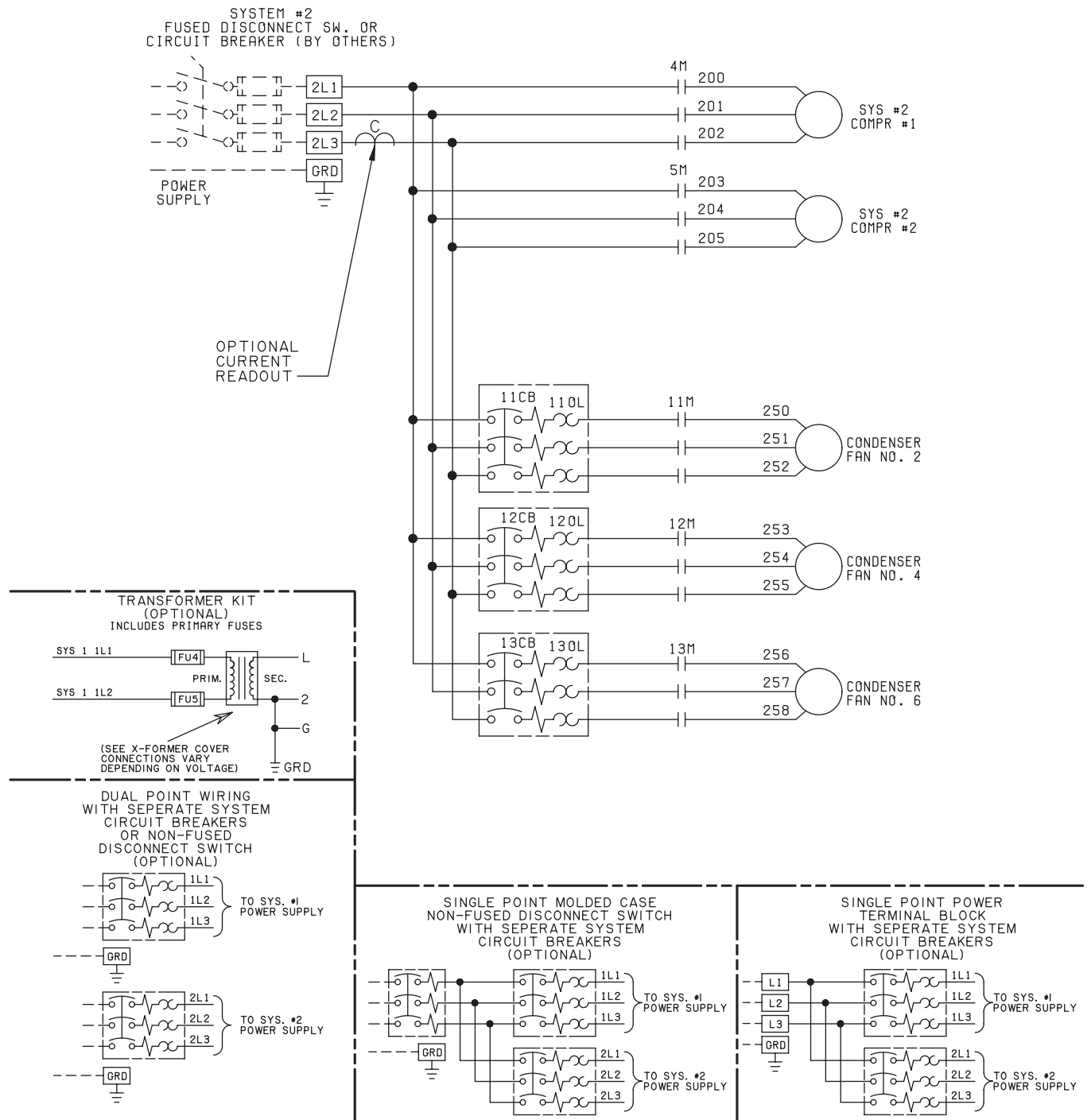

LD07843A

LD07843B

FIG. 27 – ELEMENTARY DIAGRAM, POWER CIRCUIT – YCAL0104E_

FIG. 27 – ELEMENTARY DIAGRAM, POWER CIRCUIT – YCAL0104E_ (CONT'D)

ELEMENTARY DIAGRAM YCAL0104E_

ELEMENTARY DIAGRAM MIDDLE MARKET HIGH PERFORMANCE STANDARD AND REMOTE EVAPORATOR UNITS

NOTES:

- FIELD WIRING TO BE IN ACCORDANCE WITH THE CURRENT EDITION OF THE NATIONAL ELECTRICAL CODE AS WELL AS ALL OTHER APPLICABLE CODES AND SPECIFICATIONS.
- CONTACTS MUST BE SUITABLE FOR SWITCHING 24VDC, (GOLD CONTACTS RECOMMENDED). WIRING SHALL NOT BE RUN IN THE SAME CONDUIT WITH ANY LINE VOLTAGE (CLASS 1) WIRING.
- TO CYCLE UNIT ON AND OFF AUTOMATICALLY WITH CONTACT SHOWN, INSTALL A CYCLING DEVICE IN SERIES WITH THE FLOW SWITCH. SEE NOTE 2 FOR CONTACT RATING AND WIRING SPECIFICATIONS.
- TO STOP UNIT (EMERGENCY STOP) WITH CONTACTS OTHER THAN THOSE SHOWN, INSTALL THE STOP CONTACT BETWEEN TERMINALS 5 AND 1. IF A STOP DEVICE IS NOT INSTALLED, A JUMPER MUST BE CONNECTED BETWEEN TERMINALS 5 AND 1. DEVICE MUST HAVE A MINIMUM CONTACT RATING OF 6A AT 115VOLTS A.C.
- CONTACTS ARE RATED AT 115V, 100VA, RESISTIVE LOAD ONLY, AND MUST BE SUPPRESSED AT LOAD BY USER.
- SEE INSTALLATION, OPERATION AND MAINTENANCE MANUAL WHEN OPTIONAL EQUIPMENT IS USED.
- OPTIONAL CURRENT READOUT, 5V = 225A FOR 380, 400, 460 & 575V, 5V = 450A FOR 200 & 230V CHILLERS
- IMP THRU 6MP ARE CONTAINED IN THEIR RESPECTIVE COMPRESSOR JUNCTION BOXES.

LEGEND

- TS TRANSIENT VOLTAGE SUPPRESSION
- ◻ TERMINAL BLOCK FOR CUSTOMER CONNECTIONS
- △ TERMINAL BLOCK FOR CUSTOMER LOW VOLTAGE (CLASS 2) CONNECTIONS. SEE NOTE 2.
- ◻ TERMINAL BLOCK FOR YORK CONNECTIONS ONLY
- WIRING AND COMPONENTS BY YORK
- - - - - OPTIONAL EQUIPMENT
- - - - - WIRING AND/OR COMPONENTS BY OTHERS

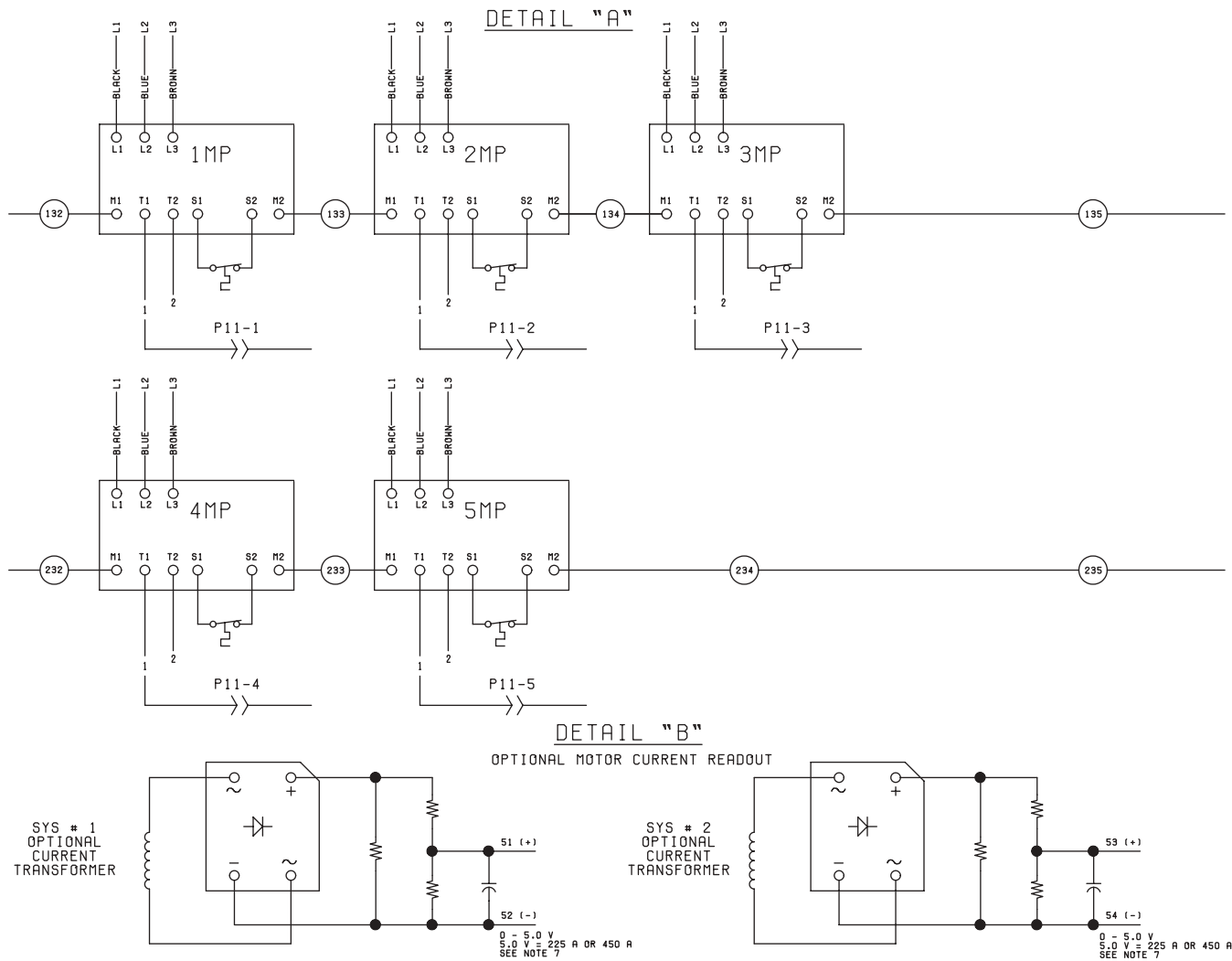

4

FIG. 28 – ELEMENTARY DIAGRAM, DETAIL "A" & DETAIL "B" – YCAL0104E_

ELEMENTARY DIAGRAM YCAL0104E_

CONNECTION DIAGRAM MIDDLE MARKET HIGH PERFORMANCE

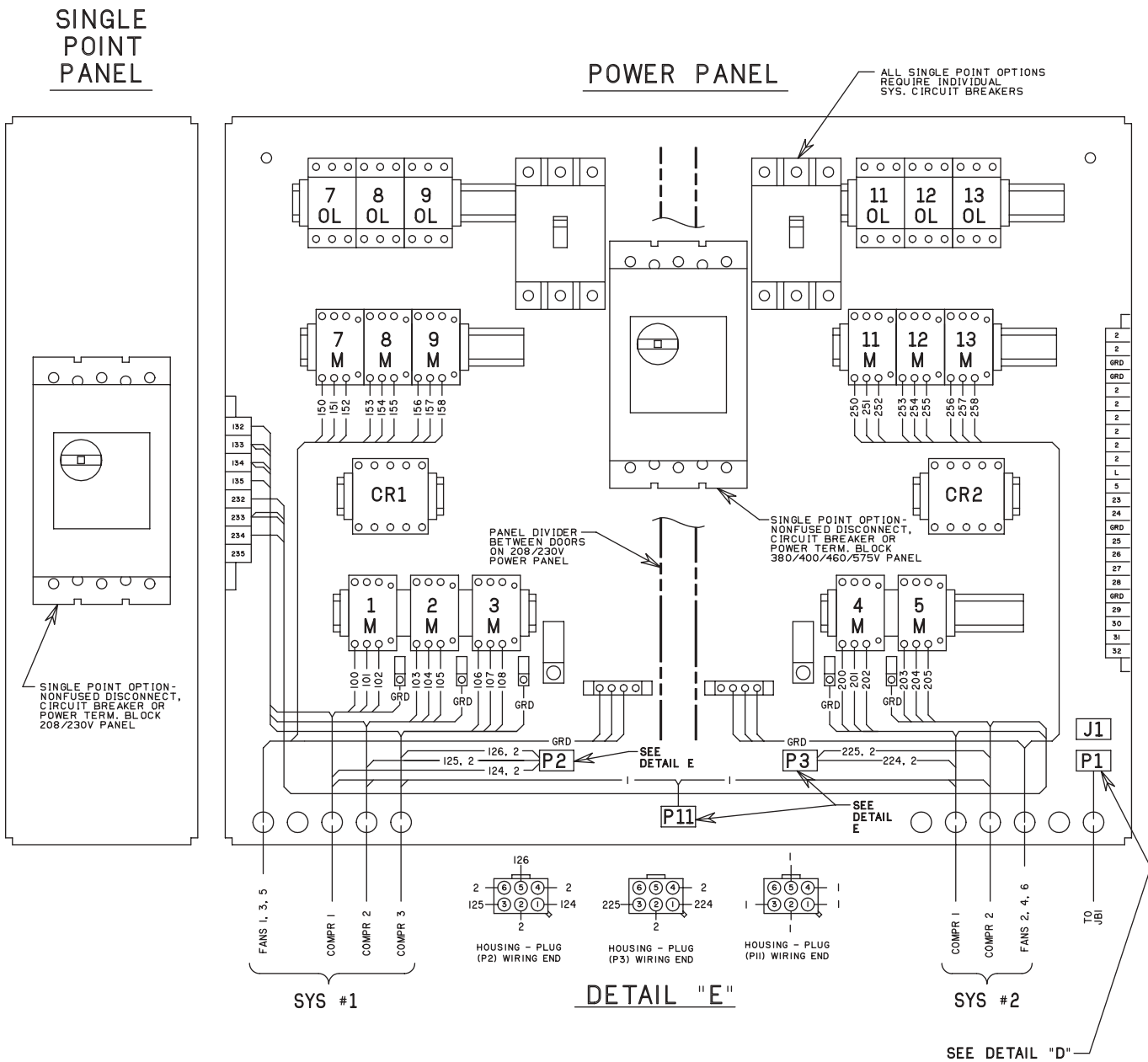

FIG. 29 - CONNECTION DIAGRAM - YCAL0104E_

MICRO PANEL

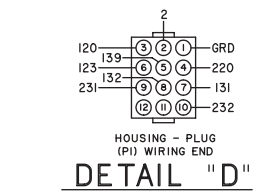
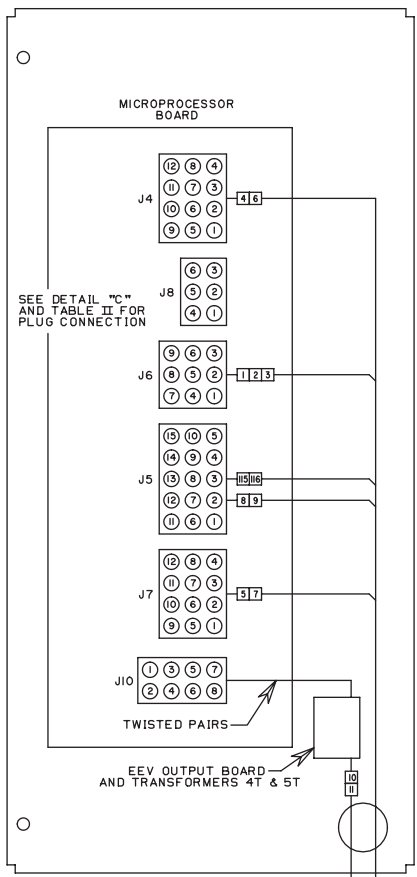
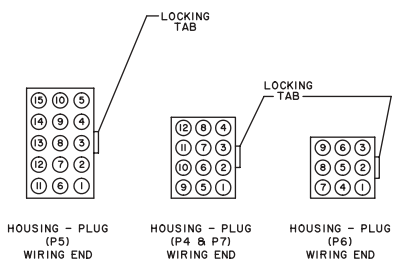
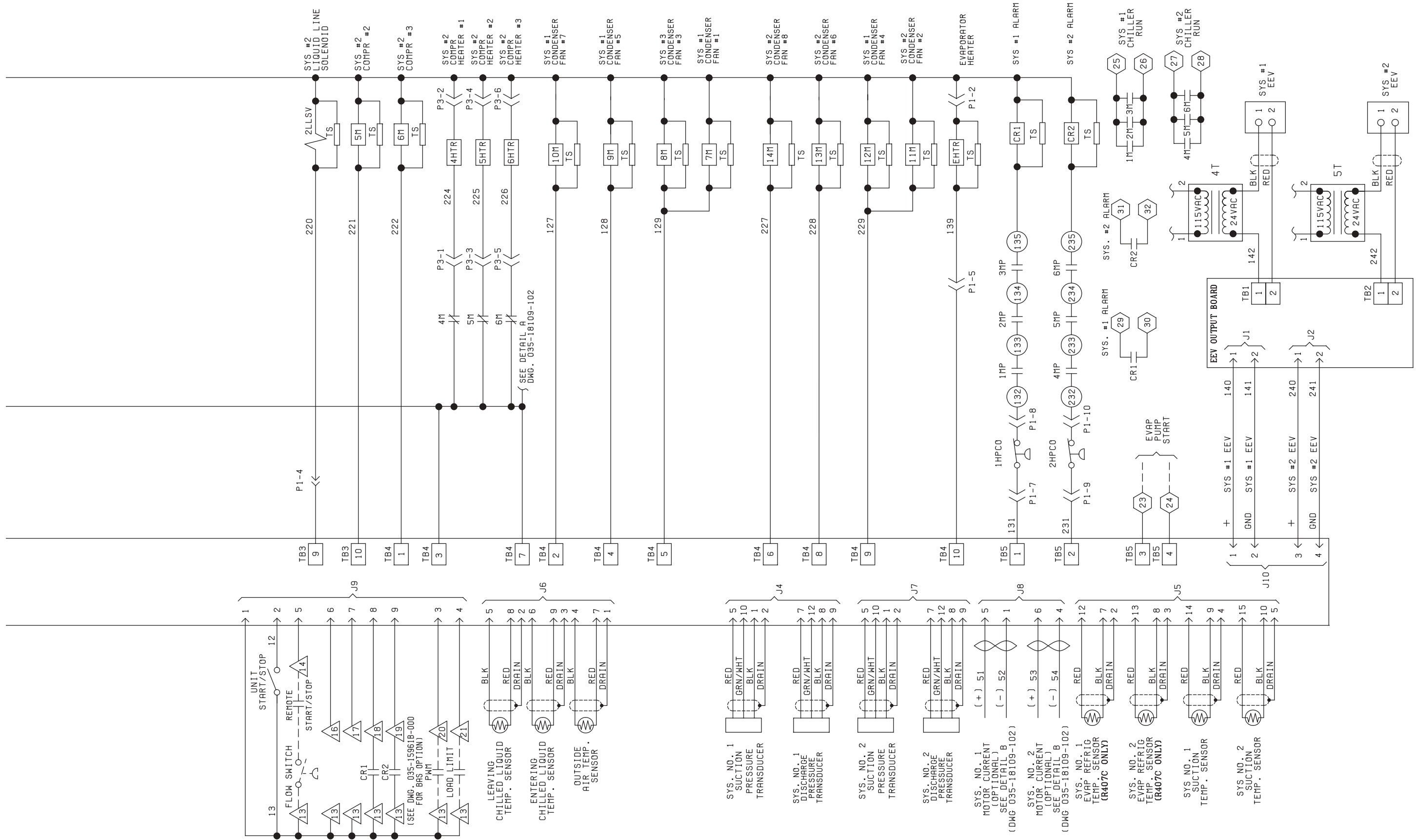

TABLE II

BOARD PLUG NO.	CABLE CODE	WIRE COLOR	PLUG PIN NO.	FUNCTION	LEGEND
MICRO P4	4	RED	5	SYS #1 SUCTION PRESSURE	ISPT
		WHT	10		
		BLK	1	SYS #1 DISCHARGE PRESSURE	
		DRAIN	2		
MICRO P6	6	RED	7	SYS #1 DISCHARGE PRESSURE	IDPT
		WHT	12		
		BLK	8	LEAVING WATER TEMP	
		DRAIN	9		
MICRO P7	1	BLK	5	LEAVING WATER TEMP	LWT
		RED	8		
		DRAIN	2		
	3	BLK	6	ENTERING WATER TEMP	EWT
		RED	9		
		DRAIN	3		
2	BLK	4	OUTSIDE AIR TEMP.	OAT	
	RED	7			
	DRAIN	1			
MICRO P5	5	RED	5	SYS #2 SUCTION PRESSURE	2SPT
		WHT	10		
		BLK	1	SYS #2 DISCHARGE PRESSURE	
		DRAIN	2		
MICRO P5	STANDARD 40°C IIS	RED	12	SYS #1 LIQ. TEMP. SENSOR	ILTS
		BLK	7		
		DRAIN	2		
	STANDARD 40°C IIS	RED	13	SYS #2 LIQ. TEMP. SENSOR	2LTS
		BLK	8		
		DRAIN	3		
8	RED	14	SYS #1 SUCTION TEMP. SENSOR	1STS	
	BLK	9			
	DRAIN	4			
9	RED	15	SYS #2 SUCTION TEMP. SENSOR	2STS	
	BLK	10			
	DRAIN	5			
EEV OUTPUT BOARD AND TRANS FORMER 4T, 5T	10	BLK (TRANS)	4T	SYS #1 EEV OUTPUT	IEEV
		RED	EEV OUTPUT BOARD TB2-2		
11	BLK (TRANS)	5T	SYS #2 EEV OUTPUT	2EEV	
	RED	EEV OUTPUT BOARD TB2-2			



LD07844



**ELEMENTARY DIAGRAM
YCAL0114E_ – YCAL0124E_**

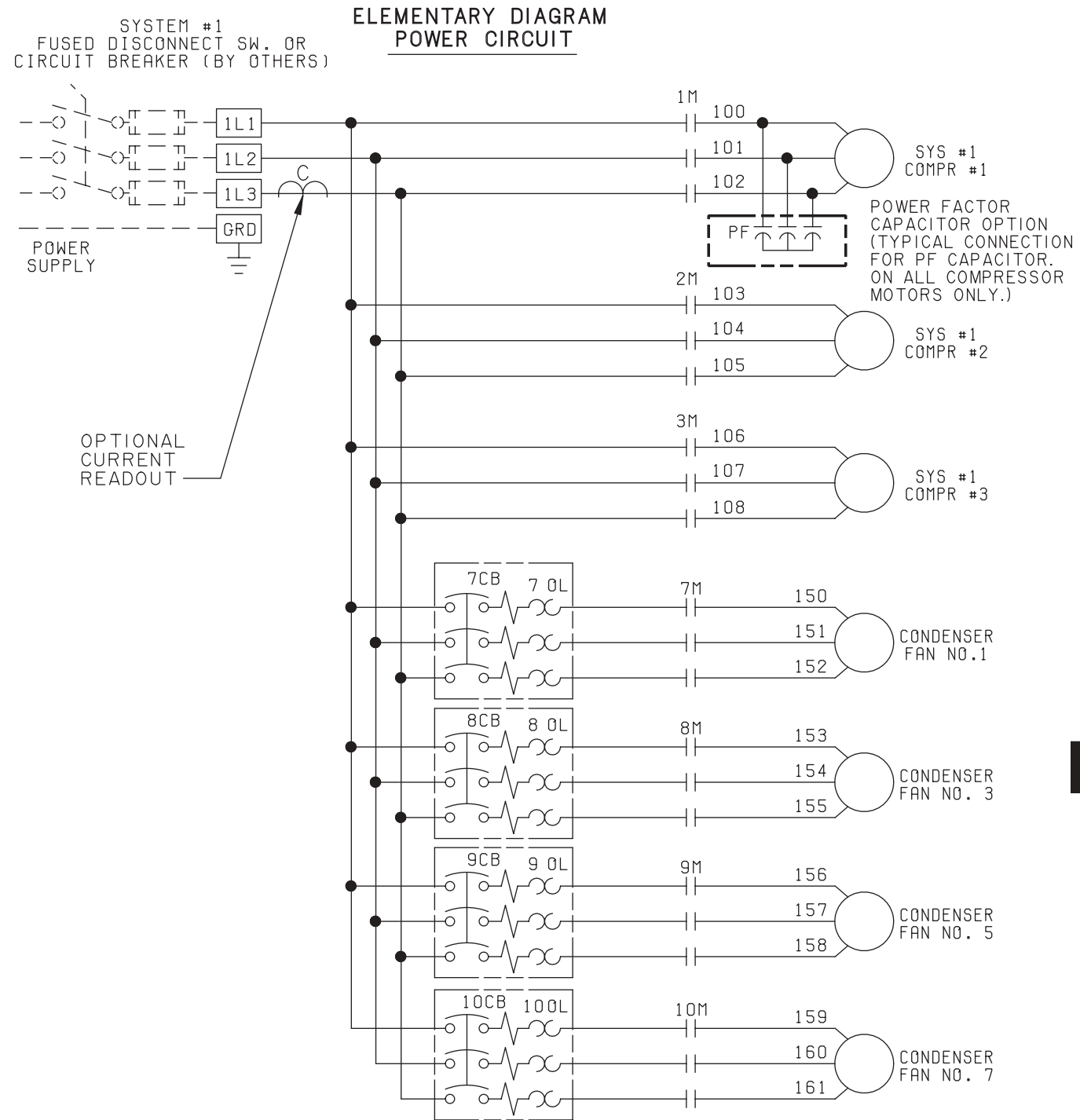

4

**ELEMENTARY DIAGRAM
YCAL0114E_ – YCAL0124E_**

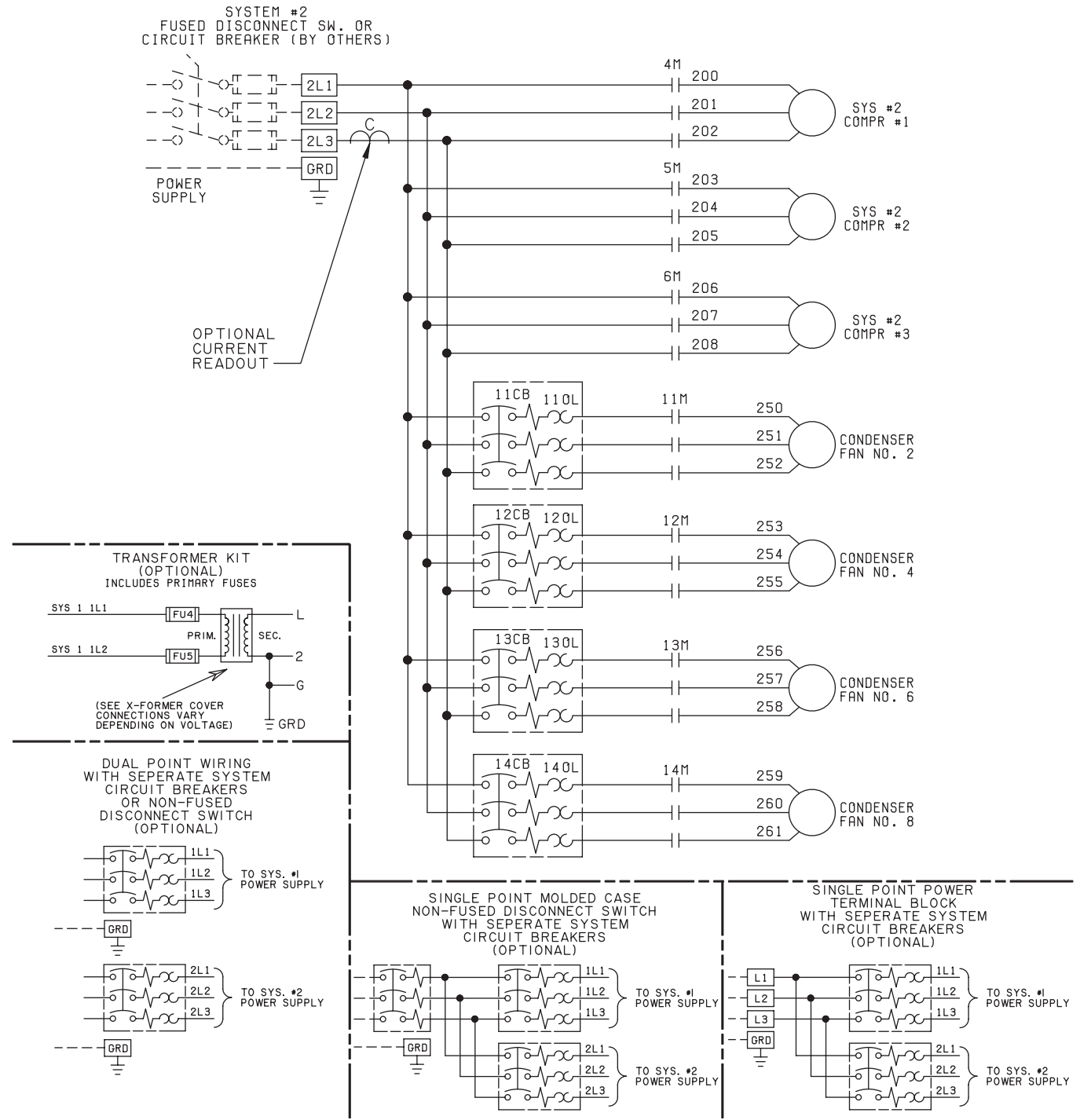

FIG. 31 – ELEMENTARY DIAGRAM, POWER CIRCUIT – YCAL0114E_ – YCAL0124E_

FIG. 31 – ELEMENTARY DIAGRAM, POWER CIRCUIT – YCAL0114E_ – YCAL0124E_ (CONT'D)

ELEMENTARY DIAGRAM YCAL0114E_ – YCAL0124E_

ELEMENTARY DIAGRAM MIDDLE MARKET HIGH PERFORMANCE STANDARD AND REMOTE EVAPORATOR UNITS

NOTES:

- FIELD WIRING TO BE IN ACCORDANCE WITH THE CURRENT EDITION OF THE NATIONAL ELECTRICAL CODE AS WELL AS ALL OTHER APPLICABLE CODES AND SPECIFICATIONS.
- CONTACTS MUST BE SUITABLE FOR SWITCHING 24VDC. (GOLD CONTACTS RECOMMENDED). WIRING SHALL NOT BE RUN IN THE SAME CONDUIT WITH ANY LINE VOLTAGE (CLASS 1) WIRING.
- TO CYCLE UNIT ON AND OFF AUTOMATICALLY WITH CONTACT SHOWN, INSTALL A CYCLING DEVICE IN SERIES WITH THE FLOW SWITCH. SEE NOTE 2 FOR CONTACT RATING AND WIRING SPECIFICATIONS.
- TO STOP UNIT (EMERGENCY STOP) WITH CONTACTS OTHER THAN THOSE SHOWN, INSTALL THE STOP CONTACT BETWEEN TERMINALS S AND I. IF A STOP DEVICE IS NOT INSTALLED, A JUMPER MUST BE CONNECTED BETWEEN TERMINALS S AND I. DEVICE MUST HAVE A MINIMUM CONTACT RATING OF 6A AT 115VOLTS A.C.
- CONTACTS ARE RATED AT 115V, 100VA, RESISTIVE LOAD ONLY, AND MUST BE SUPPRESSED AT LOAD BY USER.
- SEE INSTALLATION, OPERATION AND MAINTENANCE MANUAL WHEN OPTIONAL EQUIPMENT IS USED.
- OPTIONAL CURRENT READOUT. 5V = 225A FOR 380, 400, 460 & 575V. 5V = 450A FOR 200 & 230V CHILLERS
- IMP THRU 6MP ARE CONTAINED IN THEIR RESPECTIVE COMPRESSOR JUNCTION BOXES.

LEGEND

- TS TRANSIENT VOLTAGE SUPPRESSION
- ⬡ TERMINAL BLOCK FOR CUSTOMER CONNECTIONS
- ⬠ TERMINAL BLOCK FOR CUSTOMER LOW VOLTAGE (CLASS 2) CONNECTIONS. SEE NOTE 2.
- TERMINAL BLOCK FOR YORK CONNECTIONS ONLY
- WIRING AND COMPONENTS BY YORK
- - - OPTIONAL EQUIPMENT
- - - WIRING AND/OR COMPONENTS BY OTHERS

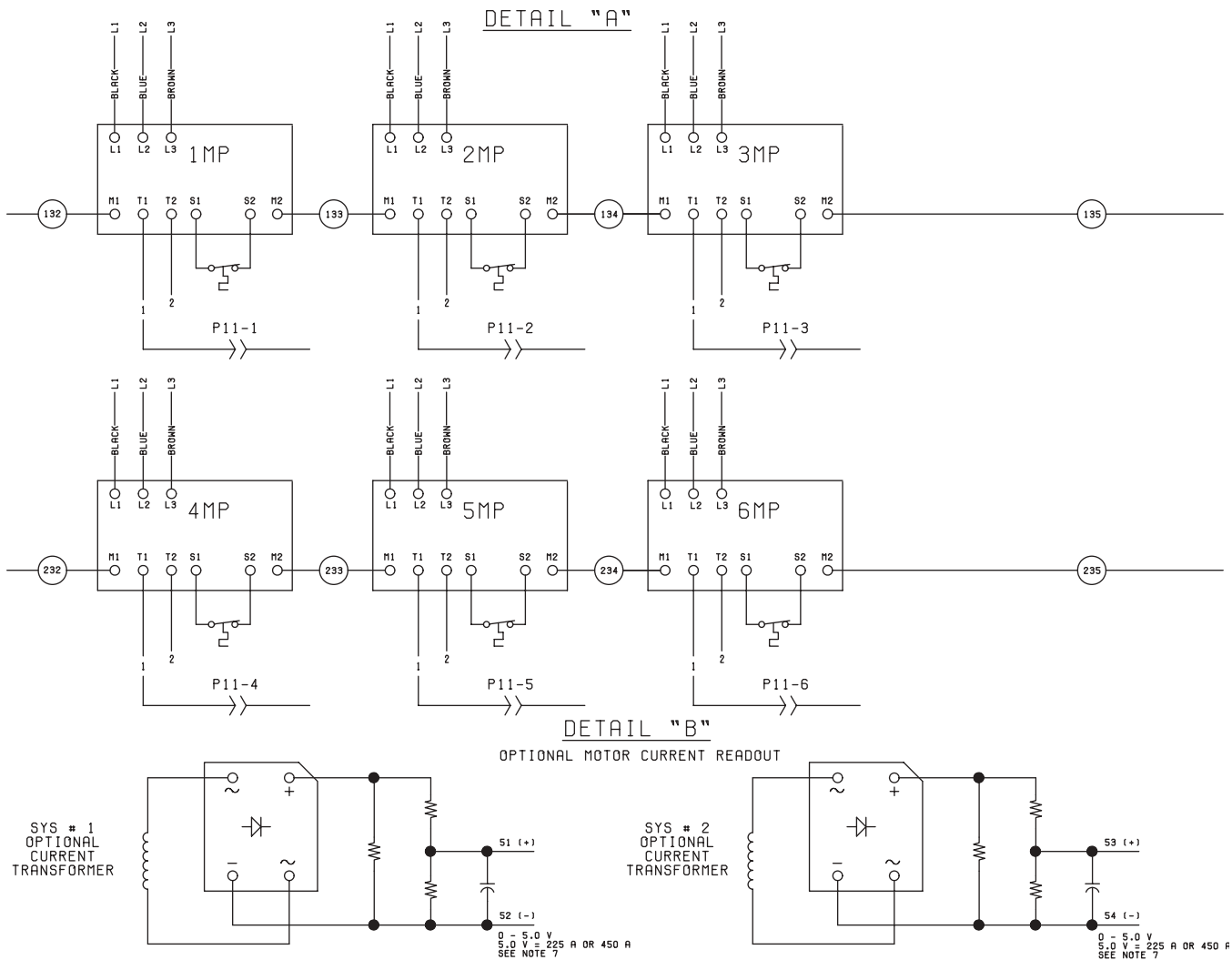

4

FIG. 32 – ELEMENTARY DIAGRAM, DETAIL "A" & DETAIL "B" – YCAL0114E_ – YCAL0124E_

MICRO PANEL

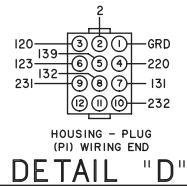
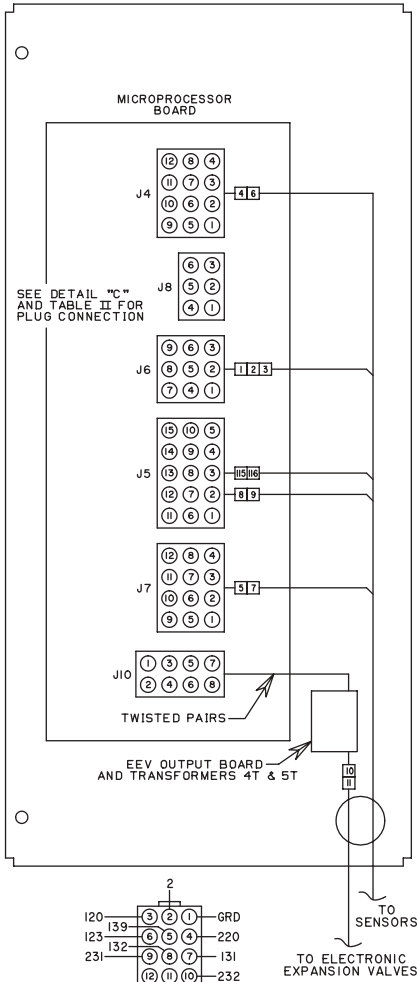
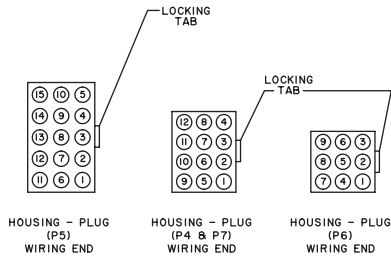

TABLE II

BOARD PLUG NO.	CABLE CODE	WIRE COLOR	PLUG PIN NO.	FUNCTION	LEGEND
MICRO P4	4	RED	5	SYS #1 SUCTION PRESSURE	ISPT
		WHT	10		
		BLK	1		
		DRAIN	2		
MICRO P6	6	RED	7	SYS #1 DISCHARGE PRESSURE	IDPT
		WHT	12		
		BLK	8		
		DRAIN	9		
MICRO P7	1	BLK	5	LEAVING WATER TEMP	LWT
		RED	8	ENTERING WATER TEMP	EWT
		DRAIN	2		
	3	BLK	6	OUTSIDE AIR TEMP.	OAT
		RED	9		
		DRAIN	3		
MICRO P5	5	RED	5	SYS #2 SUCTION PRESSURE	2SPT
		WHT	10		
		BLK	1		
	7	DRAIN	2	SYS #2 DISCHARGE PRESSURE	2DPT
		RED	7		
		WHT	12		
MICRO P5	15	RED	12	SYS #1 LIQ. TEMP. SENSOR	1LTS
		BLK	7		
		DRAIN	2		
	16	RED	13	SYS #2 LIQ. TEMP. SENSOR	2LTS
		BLK	8		
		DRAIN	3		
	8	RED	14	SYS #1 SUCTION TEMP. SENSOR	1STS
		BLK	9		
		DRAIN	4		
	9	RED	15	SYS #2 SUCTION TEMP. SENSOR	2STS
		BLK	10		
		DRAIN	5		
EEV OUTPUT BOARD AND TRANS FORMER 4T, 5T	10	BLK	4T (TRANS)	SYS #1 EEV OUTPUT	IEEV
		RED	EEV OUTPUT BOARD TB2-2		
EEV OUTPUT BOARD AND TRANS FORMER 4T, 5T	11	BLK	5T (TRANS)	SYS #2 EEV OUTPUT	2EEV
		RED	EEV OUTPUT BOARD TB2-2		



DETAIL "C"

LD07848

APPENDIX 1 – ISOLATOR SELECTIONS

ALUMINUM FIN COILS

1" DEFLECTION ISOLATOR SELECTION - VMC TYPE

Model YCAL	A	B	C	D	E	F	G	H
0014	CP-1-27	CP-1-27	CP-1-27	CP-1-27	---	---	---	---
0020	CP-1-27	CP-1-27	CP-1-27	CP-1-27	---	---	---	---
0024	CP-1-27	CP-1-27	CP-1-27	CP-1-27	---	---	---	---
0030	CP-1-27	CP-1-27	CP-1-27	CP-1-27	---	---	---	---
0034	CP-1-28	CP-1-28	CP-1-28	CP-1-28	---	---	---	---
0040	CP-2-27	CP-2-27	CP-2-27	CP-2-27	---	---	---	---
0042	CP-2-27	CP-2-27	CP-2-27	CP-2-27	---	---	---	---
0044	CP-2-27	CP-2-27	CP-2-27	CP-2-27	---	---	---	---
0050	CP-2-27	CP-2-27	CP-2-27	CP-2-27	---	---	---	---
0060	CP-2-27	CP-2-27	CP-2-27	CP-2-27	---	---	---	---
0064	CP-2-28	CP-2-28	CP-2-28	CP-2-28	---	---	---	---
0070	CP-2-31	CP-2-28	CP-2-31	CP-2-28	---	---	---	---
0074	CP-2-31	CP-2-28	CP-2-31	CP-2-28	---	---	---	---
0080	CP-2-31	CP-2-28	CP-2-31	CP-2-28	---	---	---	---
0090	CP-2-27	CP-2-27	CP-2-26	CP-2-27	CP-2-27	CP-2-26	---	---
0094	CP-2-27	CP-2-27	CP-2-26	CP-2-27	CP-2-27	CP-2-26	---	---
0104	CP-2-27	CP-2-27	CP-2-26	CP-2-25	CP-2-27	CP-2-26	CP-2-26	CP-2-25
0114	CP-2-28	CP-2-27	CP-2-26	CP-2-25	CP-2-28	CP-2-27	CP-2-26	CP-2-25
0124	CP-2-28	CP-2-27	CP-2-26	CP-2-25	CP-2-28	CP-2-27	CP-2-26	CP-2-25

SEISMIC ISOLATOR SELECTION - VMC TYPE

Model YCAL	A	B	C	D	E	F	G	H
0014	AEQM-97	AEQM-97	AEQM-97	AEQM-97	---	---	---	---
0020	AEQM-97	AEQM-97	AEQM-97	AEQM-97	---	---	---	---
0024	AEQM-97	AEQM-97	AEQM-97	AEQM-97	---	---	---	---
0030	AEQM-98	AEQM-97	AEQM-98	AEQM-97	---	---	---	---
0034	AEQM-98	AEQM-98	AEQM-98	AEQM-98	---	---	---	---
0040	AEQM-1600	AEQM-1300	AEQM-1600	AEQM-1300	---	---	---	---
0042	AEQM-1600	AEQM-1600	AEQM-1600	AEQM-1600	---	---	---	---
0044	AEQM-1600	AEQM-1600	AEQM-1600	AEQM-1600	---	---	---	---
0050	AEQM-1600	AEQM-1600	AEQM-1600	AEQM-1600	---	---	---	---
0060	AEQM-1600	AEQM-1600	AEQM-1600	AEQM-1600	---	---	---	---
0064	AEQM-1625	AEQM-1600	AEQM-1625	AEQM-1600	---	---	---	---
0070	AEQM-1625	AEQM-1625	AEQM-1625	AEQM-1625	---	---	---	---
0074	AEQM-1625	AEQM-1625	AEQM-1625	AEQM-1625	---	---	---	---
0080	AEQM-1625	AEQM-1625	AEQM-1625	AEQM-1625	---	---	---	---
0090	AEQM-1600	AEQM-1600	AEQM-1300	AEQM-1600	AEQM-1300	AEQM-1300	---	---
0094	AEQM-1600	AEQM-1600	AEQM-1300	AEQM-1600	AEQM-1300	AEQM-1300	---	---
0104	AEQM-1600	AEQM-1300	AEQM-1000	AEQM-1000	AEQM-1600	AEQM-1300	AEQM-1000	AEQM-1000
0114	AEQM-1625	AEQM-1600	AEQM-1300	AEQM-1000	AEQM-1625	AEQM-1600	AEQM-1300	AEQM-1000
0124	AEQM-1625	AEQM-1600	AEQM-1300	AEQM-1000	AEQM-1625	AEQM-1600	AEQM-1300	AEQM-1000

APPENDIX 1 – ISOLATOR SELECTIONS

COPPER FIN COILS

1" DEFLECTION ISOLATOR SELECTION - VMC TYPE

Model YCAL	A	B	C	D	E	F	G	H
0014	CP-1-27	CP-1-27	CP-1-27	CP-1-27	---	---	---	---
0020	CP-1-27	CP-1-27	CP-1-27	CP-1-27	---	---	---	---
0024	CP-1-27	CP-1-27	CP-1-27	CP-1-27	---	---	---	---
0030	CP-1-27	CP-1-28	CP-1-27	CP-1-28	---	---	---	---
0034	CP-1-28	CP-1-28	CP-1-28	CP-1-28	---	---	---	---
0040	CP-2-27	CP-2-27	CP-2-27	CP-2-27	---	---	---	---
0042	CP-2-27	CP-2-27	CP-2-27	CP-2-27	---	---	---	---
0044	CP-2-27	CP-2-27	CP-2-27	CP-2-27	---	---	---	---
0050	CP-2-27	CP-2-27	CP-2-27	CP-2-27	---	---	---	---
0060	CP-2-28	CP-2-28	CP-2-28	CP-2-28	---	---	---	---
0064	CP-2-31	CP-2-28	CP-2-31	CP-2-28	---	---	---	---
0070	CP-2-31	CP-2-31	CP-2-31	CP-2-31	---	---	---	---
0074	CP-2-31	CP-2-31	CP-2-31	CP-2-31	---	---	---	---
0080	CP-2-31	CP-2-31	CP-2-31	CP-2-31	---	---	---	---
0090	CP-2-28	CP-2-27	CP-2-27	CP-2-28	CP-2-27	CP-2-27	---	---
0094	CP-2-28	CP-2-27	CP-2-27	CP-2-28	CP-2-27	CP-2-27	---	---
0104	CP-2-28	CP-2-27	CP-2-26	CP-2-26	CP-2-28	CP-2-27	CP-2-26	CP-2-25
0114	CP-2-31	CP-2-28	CP-2-27	CP-2-26	CP-2-31	CP-2-28	CP-2-27	CP-2-26
0124	CP-2-31	CP-2-28	CP-2-27	CP-2-26	CP-2-31	CP-2-28	CP-2-27	CP-2-26

SEISMIC ISOLATOR SELECTION - VMC TYPE

Model YCAL	A	B	C	D	E	F	G	H
0014	AEQM-97	AEQM-97	AEQM-97	AEQM-97	---	---	---	---
0020	AEQM-97	AEQM-97	AEQM-97	AEQM-97	---	---	---	---
0024	AEQM-97	AEQM-97	AEQM-97	AEQM-97	---	---	---	---
0030	AEQM-98	AEQM-98	AEQM-98	AEQM-98	---	---	---	---
0034	AEQM-98	AEQM-98	AEQM-98	AEQM-98	---	---	---	---
0040	AEQM-1600	AEQM-1600	AEQM-1600	AEQM-1600	---	---	---	---
0042	AEQM-1600	AEQM-1600	AEQM-1600	AEQM-1600	---	---	---	---
0044	AEQM-1600	AEQM-1600	AEQM-1600	AEQM-1600	---	---	---	---
0050	AEQM-1600	AEQM-1600	AEQM-1600	AEQM-1600	---	---	---	---
0060	AEQM-1625	AEQM-1625	AEQM-1625	AEQM-1625	---	---	---	---
0064	AEQM-1628	AEQM-1625	AEQM-1628	AEQM-1625	---	---	---	---
0070	AEQM-1628	AEQM-1628	AEQM-1628	AEQM-1628	---	---	---	---
0074	AEQM-1628	AEQM-1628	AEQM-1628	AEQM-1628	---	---	---	---
0080	AEQM-1628	AEQM-1628	AEQM-1628	AEQM-1628	---	---	---	---
0090	AEQM-1600	AEQM-1600	AEQM-1600	AEQM-1600	AEQM-1600	AEQM-1600	---	---
0094	AEQM-1600	AEQM-1600	AEQM-1600	AEQM-1600	AEQM-1600	AEQM-1600	---	---
0104	AEQM-1625	AEQM-1600	AEQM-1300	AEQM-1000	AEQM-1600	AEQM-1300	AEQM-1300	AEQM-1000
0114	AEQM-1625	AEQM-1625	AEQM-1600	AEQM-1300	AEQM-1625	AEQM-1600	AEQM-1300	AEQM-1000
0124	AEQM-1625	AEQM-1625	AEQM-1600	AEQM-1300	AEQM-1625	AEQM-1600	AEQM-1300	AEQM-1000

APPENDIX 1 (DIMENSIONS)

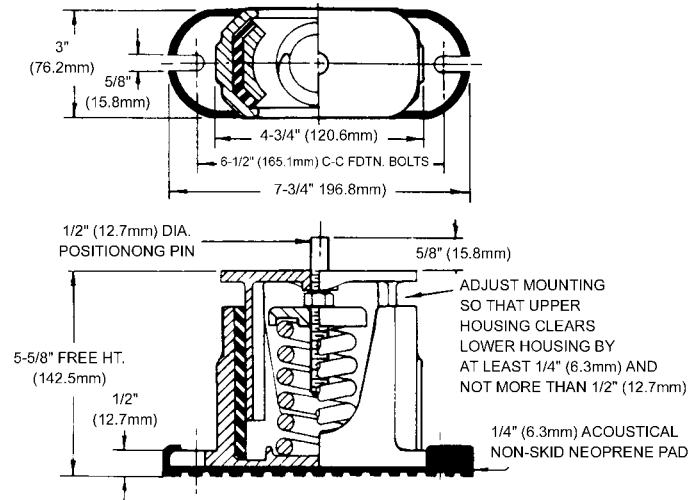

LD03839

FIG. 34 – TYPE CP 1

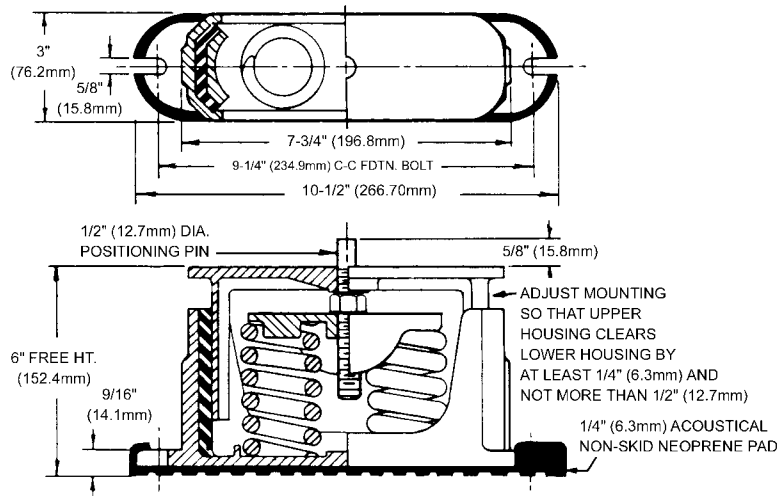

LD03840

FIG. 35 – TYPE CP 2

ISOLATOR SPRING IDENTIFICATION TABLE

1" DEFLECTION			SEISMIC		
MODEL	PART- #	COLOR	MODEL	PART #	COLOR
CP-1-27	308439-27	ORANGE	AEQM-97	301055-97	WHITE
CP-1-28	308439-28	GREEN	AEQM-98	301055-98	GRAY
CP-2-25	308439-25	RED	AEQM-1000	30106-1000	GREEN
CP-2-26	308692-26	PURPLE	AEQM-1300	30106-1300	YELLOW
CP-2-27	308962-27	ORANGE	AEQM-1600	301060-1600	GRAY
CP-2-28	308692-28	GREEN	AEQM-1625	301060-1625	RED
CP-2-31	308692-31	GRAY	AEQM-1628	301060-1628	GRAY/GREEN

APPENDIX 1 (DIMENSIONS)

MODEL #	A	B	C	D	E	F	G	H	J
AEQM-97	7	5-1/2	4-1/2	2-1/2	5/8	1/4	7-1/4	5/8	3/8
AEQM-98	7	5-1/2	4-1/2	2-1/2	5/8	1/4	7-1/4	5/8	3/8
AEQM-99	7	5-1/2	4-1/2	2-1/2	5/8	1/4	7-1/4	5/8	3/8
AEQM-1000	8-1/2	6-1/2	6	4-1/2	3/4	3/8	8-3/8	7/8	1/2
AEQM-1300	8-1/2	6-1/2	6	4-1/2	3/4	3/8	8-3/8	7/8	1/2
AEQM-1600	8-1/2	6-1/2	6	4-1/2	3/4	3/8	8-3/8	7/8	1/2
AEQM-1625	8-1/2	6-1/2	6	4-1/2	3/4	3/8	8-3/8	7/8	1/2
AEQM-1628	8-1/2	6-1/2	6	4-1/2	3/4	3/8	8-3/8	7/8	1/2

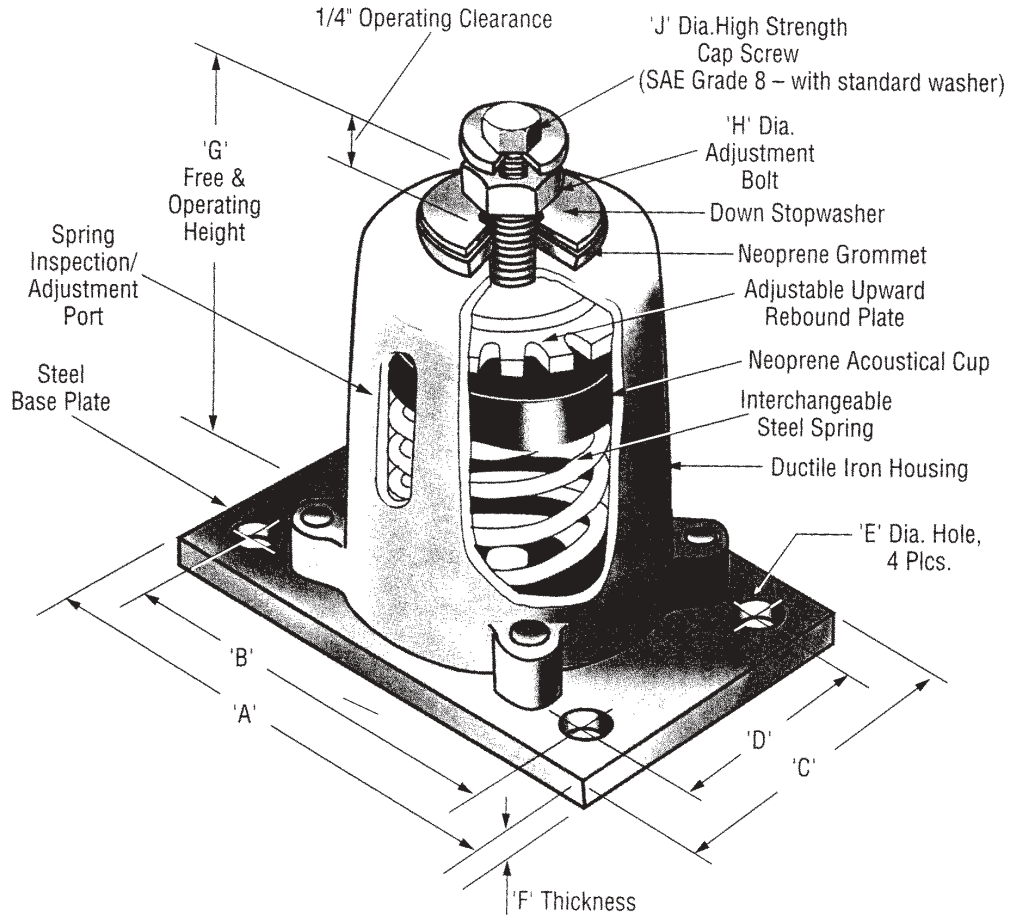

FIG. 36 – R SPRING SEISMIC ISOLATOR

LD04045

APPENDIX 1

INSTALLATION AND ADJUSTING INSTALLATIONS
TYPE CP MOUNTING

Mountings are shipped completely assembled, ready to install.

1. Locate mountings under equipment at positions shown on tags or on VM layout drawings, or as indicated on packing slip or correspondence.
2. Set mountings on subbase, shimming or grouting where required to provide flat and level surface at the same elevation for all mountings (1/4" maximum difference in elevation can be tolerated). Support the full underside of the base plate – do not straddle gaps or small shims.
3. Unless specified, mountings need not be fastened to floor in any way. If required, bolt mountings to floor through slots.
4. Set the machine or base on the mountings. The weight of the machine will cause the upper housing

of the mount to go down, possibly resting on the lower housing.

5. If clearance "X" is less than 1/4" on any mounting, with wrench turn up one complete turn on the adjusting bolt of each mounting. Repeat this procedure until 1/4", clearance at "X" is obtained on one or more mountings.
6. Take additional turns on all mountings having less than 1/4" clearance, until all mountings have at least this clearance.
7. Level the machine by taking additional turns on all mounts at the low side. Clearance should not exceed 1/2" - greater clearance indicates that mountings were not all installed at the same elevation, and shims are required. This completes adjustment.

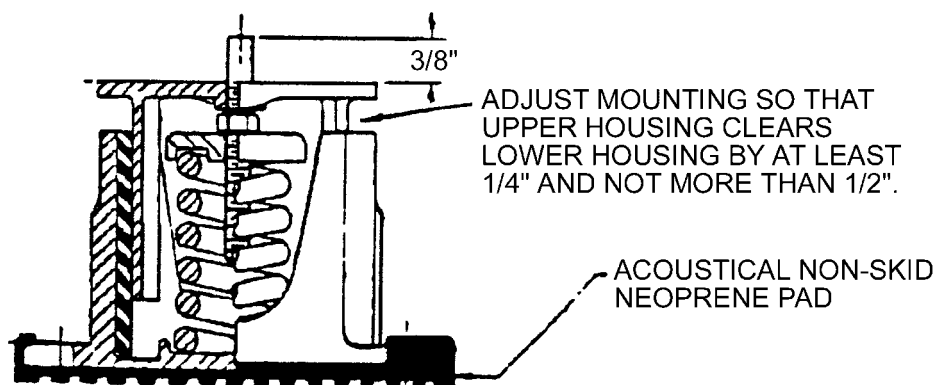

LD03837

FIG. 37 – TYPE CP MOUNTING

APPENDIX 1

“AEQM” SPRING-FLEX MOUNTING INSTALLATION AND ADJUSTMENT INSTRUCTIONS

1. Isolators are shipped fully assembled and are to be spaced and located in accordance with installation drawings or as otherwise recommended.
 - 1a. Locate spring port facing outward from equipment or base so that spring is visible.
2. To facilitate installation, prior to installing, VMC recommends turning adjusting bolt “B” so that the “Operating Clearance” marked “*” is approximately 1" to 1-1/2" for 1" deflection units, 1-1/2" to 2" for 1-1/2" deflection units, and 2" to 2-1/2" for 2" deflection units.
3. Locate isolators on floor or subbase as required, ensuring that the isolator centerline matches the equipment or equipment base mounting holes. Shim and/or grout as required to level all isolator base plates “A”. A 1/4" maximum difference in elevation can be tolerated.
4. Anchor all isolators to floor or subbase as required. For installing on concrete VMC recommends HILTI type HSL heavy duty anchors or equal.
5. Remove cap screw “C” and save. Gently place machine or machine base on top of bolt “B”. Install cap screw “C” but **DO NOT** tighten.
6. The weight of the machine will cause the spring and thus bolt “B” to descend.
7. Adjust all isolators by turning bolt “B” so that the operating clearance “*” is approximately 1/4". NOTE: It may be necessary to adjust rebound plate “D” for clearance.
6. Check equipment level and fine adjust isolators to level equipment.
9. Adjust rebound plate “D” so that the operating clearance “**” is no more than 1/4".
10. Tighten cap screw “C”. Adjustment is complete.

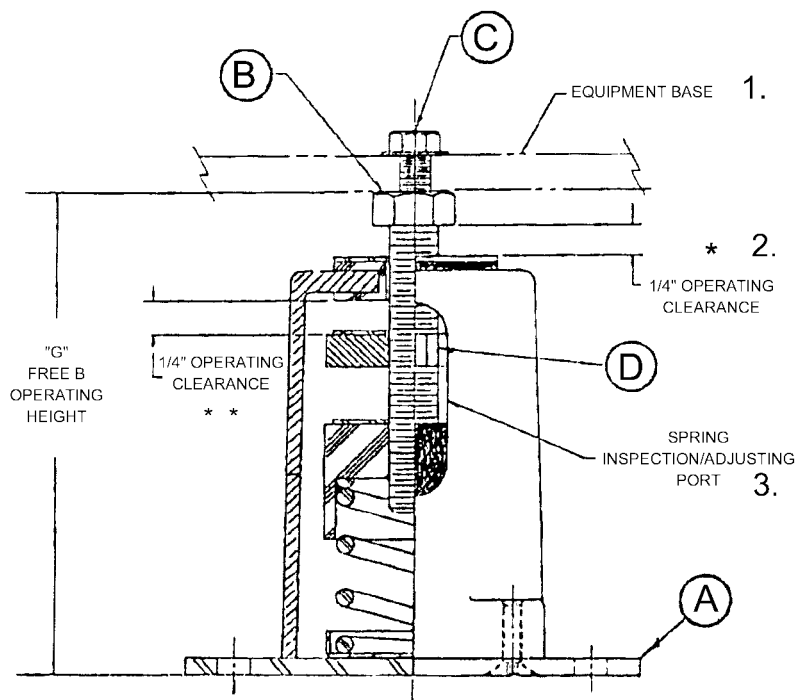

FIG. 38 – “AEQM” SPRING-FLEX MOUNTING

YORK SERVICE OFFICES - NORTH AMERICA

ALABAMA

Birmingham

York International Corp.
(205) 987-0458

ARIZONA

Phoenix

York International Corp.
(602) 220-9400

CALIFORNIA

Los Angeles

York International Corp.
(714) 897-0997

San Francisco

York International Corp.
(925) 426-1166

San Diego

York International Corp.
(858) 268-0770

COLORADO

Denver

York International Corp.
(303) 649-1500

CONNECTICUT

Danbury

York International Corp.
(203) 730-8100

FLORIDA

Miami

York International Corp.
(954) 389-9675

Tampa

York International Corp.
(813) 621-1323

Orlando

York International Corp.
(407) 444-2261

GEORGIA

Atlanta

York International Corp.
(404) 417-9257

HAWAII

Honolulu

York International Corp.
(808) 596-0761

ILLINOIS

Chicago

York International Corp.
(847) 520-1910

INDIANA

Indianapolis

York International Corp.
(317) 595-3050

KENTUCKY

Louisville

York International Corp.
(502) 499-6020

LOUISIANA

New Orleans

York International Corp.
(504) 464-6941

MARYLAND

Baltimore/Washington

York International Corp.
(410) 720-6383

MASSACHUSETTS

Boston

York International Corp.
(781) 769-7950

MICHIGAN

Detroit

York International Corp.
(248) 689-7277

MINNESOTA

Minneapolis

York International Corp.
(612) 780-4446

MISSOURI

Kansas City

York International Corp.
(816) 221-9675

St. Louis

York International Corp.
(314) 770-0909

NEW JERSEY

Newark

York International Corp.
(732) 225-0606

NEVADA

Las Vegas

York International Corp.
(702) 873-2200

NEW YORK

Rochester

York International Corp.
(716) 426-0260

New York

York International Corp.
(212) 843-1602

NORTH CAROLINA

Charlotte

York International Corp.
(704) 598-0000

Greensboro

York International Corp.
(336) 299-9675

Raleigh

York International Corp.
(919) 431-9675

OHIO

Cincinnati

York International Corp.
(513) 489-8871

Cleveland

York International Corp.
(216) 447-0696

Columbus

York International Corp.
(614) 841-5242

PENNSYLVANIA

Philadelphia

York International Corp.
(610) 640-2320

Pittsburgh

York International Corp.
(412) 364-6600

York (HQ)

York International Corp.
(717) 771-6561

SOUTH CAROLINA

Greenville

York International Corp.
(864) 627-9675

TENNESSEE

Kingsport

York International Corp.
(423) 349-2450

Nashville

York International Corp.
(615) 833-9675

TEXAS

Austin

York International Corp.
(512) 481-0220

Dallas

York International Corp.
(972) 241-1219

Houston

York International Corp.
(713) 782-5200

San Antonio

York International Corp.
(210) 496-6631

UTAH

Salt Lake City

York International Corp.
(801) 261-1200

VIRGINIA

Richmond

York International Corp.
(804) 359-2600

Norfolk

York International Corp.
(757) 857-8625

WASHINGTON

Seattle

York International Corp.
(425) 251-9145

CANADA

Ottawa, Ontario

(613) 596-9111

Toronto, Ontario

(905) 890-6812

Laval, Quebec

(514) 387-6000

York Applied Systems field office listing subject to change. See us on the web at <http://www.york.com> for additional information.

