



**AIR-COOLED LIQUID CHILLERS
HERMETIC SCROLL**

RENEWAL PARTS

New Release

Form: 150.66-RP3 (106)

**MODELS YCAL 0041, 0045, 0051, 0055, 0061, AND YCAL0065E
STYLE "D"**



29302A

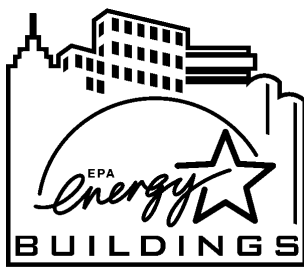

ALLY

40 - 70 TON
35 - 246 Kw
50Hz and 60Hz



200-3-60
230-3-60
315-3-60
380/415-50
460-3-60
575-3-60
MODELS ONLY

CHANGEABILITY OF THIS DOCUMENT

In complying with YORK's policy for continuous improvement, the information contained in this document is subjected to change without notice. While YORK makes no commitment to update or provide current information automatically to the manual user, that information, if applicable, can be obtained by contacting the nearest YORK Engineered Systems Service office.

It is the responsibility of operating/service personnel as to the applicability of these documents to the equipment in question. If there is any question in the mind of operating/ service personnel as to the applicability of these documents, then, prior to working on the equipment, they should verify with the owner, whether the equipment has been modified and if the current literature is available.

WARNING

HIGH VOLTAGE

Is used in the operation of this equipment.

DEATH OR SERIOUS INJURY

may result if personnel fail to observe safety precautions.

Work on electronic equipment should not be undertaken unless the individual(s) have been trained in the proper maintenance of equipment and is (are) familiar with its potential hazards.

Shut off power supply to the equipment before beginning work and follow lockout procedures. When working inside equipment with power off, take care to discharge every capacitor likely to hold dangerous potential.

Be careful not to contact high voltage connections when installing or operating this equipment.

LOW VOLTAGE

DO NOT be misled by the term "low voltage." Voltages as low as 50 volts may cause death.

TABLE OF CONTENTS

	<u>PAGE</u>
UNIT NOMENCLATURE NAMEPLATE ENGINEERING DATA	4
EVAPORATOR	
HEAT EXCHANGER AND RELATED COMPONENTS.....	6
CONDENSER COILS	
CONDENSER COIL COMPONENTS	8
FAN	
FAN COMPONENTS	10
PIPING	
REFRIGERANT PIPING COMPONENTS.....	11
COMPRESSOR	
COMPRESSOR	18
CONTROL AND POWER PANEL	
CONTROL PANEL AND POWER PANEL CONFIGURATIONS.....	20
CONTROL PANEL AND POWER PANEL COMPONENTS	21
CONTROL WIRING HARNESSSES	33
SENSOR WIRING HARNESSSES	34
TEMPERATURE SENSORS AND TRANSDUCERS	35
TRANSDUCER AND THERMISTOR WIRE HARNESS CONNECTORS	36
ENCLOSURE	
UNIT ENCLOSURE COMPONENTS.....	38
CHILLER OPTIONS	
VIBRATOR ISOLATORS	40
CHILLER OPTIONS	41
ENCLOSURE KIT OPTIONS	42
OPTIVIEW REMOTE CONTROL CENTER	44
REMOTE CURRENT/TEMPERATURE RESET PARTS BREAKDOWN	45
RECOMMENDED SPARE PARTS.....	46

UNIT NOMENCLATURE NAMEPLATE ENGINEERING DATA

BASIC PART NUMBER

YCAL0061EC28XDA

1	2	3	4	5	6	7	8	9	10	11	12	13	14	15
BASE PRODUCT TYPE				NOMINAL CAPACITY				UNIT DESIGNATOR	REFRIGERANT	VOLTAGE/STARTER			DESIGN/DEVELOPMENT LEVEL	
Y	C	A	L	#	#	#	#	E	C	1	7		D	
: YORK : Chiller : Air Cooled L : Scroll				Tons/Kw 0012 to 0065				High Efficiency	:R-22	200/3/60 230/3/60 380/3/60 460/3/60 385-415/3/50 575/3/60	:Design Series D A :Engineering Change or PIN Level			
													X :Across the Line	

PART NUMBER – LETTER CODES

16 17 18 19	20 21 22 23 24 25 26 27 28	29 30 31 32 33 34 35 36 37
POWER FIELD	CONTROLS FIELD	COMPRESSOR / PIPING FIELD
S X S D B X T C	L H A M T S F G R L C O	# # T S C S B 1 X
: SP Terminal Block : SP NF Disconnect Switch : SP Circuit Breaker : Transformer 115/24V (factory) : Power Factor Capacitor	: Low Ambient Kit (factory) : High Ambient Kit (factory) : Both Low / High Ambient (factory) : ISN Microgateway : BAS/EMS Temp. Reset / Offset : Spanish LCD & Keypad Display : French LCD & Keypad Display : German LCD & Keypad Display : Disch Press Transducers / Readout : N. American Safety Code (cU.L./cE) : Motor Current Module : OptiView Remote Control Panel S : Sequence Control & Automatic Lead Transfer	:Low Temp. Brine (LBrT) :Thermal Storage :Chicago Relief Code :Serv Isolation Valves :Both Chicago Code & Serv Isolation :Hot Gas By-Pass (# circuits) X :Comp. Heater (R-22)

MP = Multiple Point
SP = Single Point
NFDS = Non-Fused Disconnect Switch
TB = Terminal Block
Ser. = Service
CB = Circuit Breaker

38 39 40 41 42 43 44	45 46 47	48 49 50 51 52 53 54	55	61
EVAP. FIELD	CONDENSER FIELD	CABINET FIELD	EXTENDED FIELD WARRANTY	PLANT OF MANUFACTURE
3 D X V S T U D E F A R	X C B P X	X 7 B L	X B C D E F G H	B R
: 300 PSIG DWP Waterside : Double Thick Insulation : Weld Flange Kit : Victaulic Flange Kit : One Flow Switch : Two Flow Switch : Three Flow Switch : One Diff. Press. Switch : Two Diff. Press. Switch : Three Diff. Press. Switch : ASME Pressure Vessel & Associated Codes : Remote DX Cooler	: Aluminum : Copper : Black Fin : Phenolic X : TEAO Fan Motors	: Wire Enclosure Panels (factory) : Louvered Enclosure Panels (factory) : Acoustic Sound Blanket : Ultra Low Sound Fans 1 : 1" Deflection S : Seismic N : Neoprene Pads	: 1st Year Parts Only : 1st Year Parts & Labor : 2nd Year Parts Only : 2nd Year Parts & Labor : 5 Year Compressor Parts Only : 5 Year Compressor Parts & Labor Only : 5 Year Units Parts Only : 5 Year Unit Parts & Labor	: Basildon : Monterrey

56 REFRIGERANT WARRANTY
 1 : 1 Year Refrigerant
 2 : 2 Year Refrigerant
 5 : 5 Year Refrigerant

NOTES:
 1. Q :DENOTES SPECIAL / S.Q.
 2. # :DENOTES STANDARD
 3. X :w/in OPTIONS FIELD, DENOTES NO OPTION SELECTED
 4. Agency Files (i.e. U.L. / ETL; CE; ARI; ETC.) will contain info. based on the first 14 characters only.
 5. Plant of manufacture to include PIN 56 upon entering the chiller order.

HEAT EXCHANGER AND RELATED COMPONENTS

Service Note: Pin Location 38 in Model Number will be "X" for 150# cooler.
"3" for 300# cooler.

FLOW SWITCHES:

Standard 150# DWP cooler - 024-26116-000

Optional 300# DWP cooler - 024-12144-000

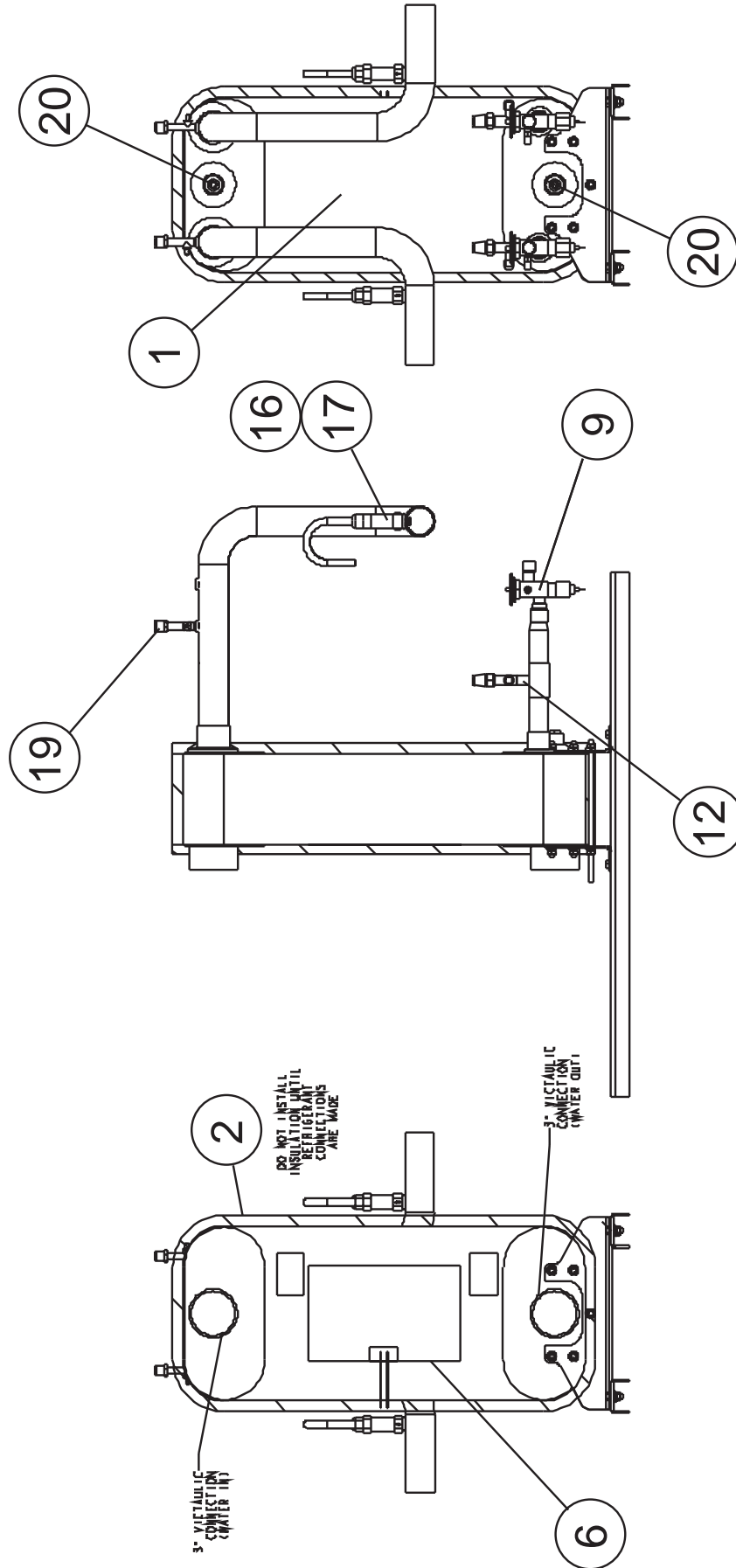

30968-000

FIG. 1 –HEAT EXCHANGER COMPONENTS (REF. TABLE 1, PAGES 6 AND 7)

HEAT EXCHANGER AND RELATED COMPONENTS (CONT'D)

TABLE 1 – HEAT EXCHANGER AND RELATED COMPONENTS (SEE FIG. 1, PAGE 5)

ITEM NUMBER	QTY PER UNIT	DESCRIPTION	DWP	UNIT MODEL YCAL0041	UNIT MODEL YCAL0045
				375-59428-001	375-59422-001
1	1	Heat Exchanger, less Heater & Insulation	ALL	375-59427-001	375-59421-002
2	-	Insulation (3/4"x49"x65")	ALL	010-05997-000	010-05997-000
	-	Insulation (1 1/2"x49"x65")		010-05998-000	010-05998-000
6	1	Heater, Cooler 100 Watt	ALL	025-40272-000	025-40272-000
9	2	Valve, Thermal Expansion	ALL	025-27535-000	025-27535-000
12	2	Valve, Charging	ALL	022-09754-000	022-09754-000
16	2	Valve, Relief	ALL	022-11386-000	022-11386-000
17	2	Tube	ALL	375-37978-000	375-37978-000
19	2	Valve	ALL	022-00009-000	022-00009-000
20	2	Well, Thermo	ALL	025-32328-000	025-32328-000

ITEM NUMBER	QTY PER UNIT	DESCRIPTION	DWP	UNIT MODEL YCAL0051	UNIT MODEL YCAL0055
				375-59521-001	375-58507-001
1	1	Heat Exchanger, less Heater & Insulation	ALL	375-59520-002	375-58505-003
2	-	Insulation (3/4"x49"x65")	ALL	010-05997-000	010-05997-000
	-	Insulation (1 1/2"x49"x65")		010-05998-000	010-05998-000
6	1	Heater, Cooler 100 Watt	ALL	025-40272-000	025-40272-000
9	2	Valve, Thermal Expansion	ALL	025-27536-000	025-27536-000
12	2	Valve, Charging	ALL	022-09754-000	022-09754-000
16	2	Valve, Relief	ALL	022-11386-000	022-11386-000
17	2	Tube	ALL	375-37978-000	375-37978-000
19	2	Valve	ALL	022-00009-000	022-00009-000
20	2	Well, Thermo	ALL	025-32328-000	025-32328-000

HEAT EXCHANGER AND RELATED COMPONENTS (CONT'D)

TABLE 1 (CONT'D) – HEAT EXCHANGER AND REALTED COMPONENTS (SEE FIG. 1, PAGE 5)

ITEM NUMBER	QTY PER UNIT	DESCRIPTION	DWP	UNIT MODEL YCAL0061	UNIT MODEL YCAL0065
				375-59502-001	375-58503-001
1	1	Heat Exchanger, less Heater & Insulation	ALL	375-58501-004	375-58489-004
2	-	Insulation (3/4"x49"x65")	ALL	010-05997-000	010-05997-000
	-	Insulation (1 1/2"x49"x65")		010-05998-000	010-05998-000
6	1	Heater, Cooler 100 Watt	ALL	025-40272-000	025-40272-000
9	1	Valve, Thermal Expansion	Sys 1	025-27536-000	025-27536-000
	1		Sys 2	025-20213-000	025-20213-000
12	2	Valve, Charging	ALL	022-09754-000	022-09754-000
16	2	Valve, Relief	ALL	022-11386-000	022-11386-000
17	2	Tube	ALL	375-37978-000	375-37978-000
19	2	Valve	ALL	022-00009-000	022-00009-000
20	2	Well, Thermo	ALL	025-32328-000	025-32328-000

CONDENSER COIL COMPONENTS

Condenser

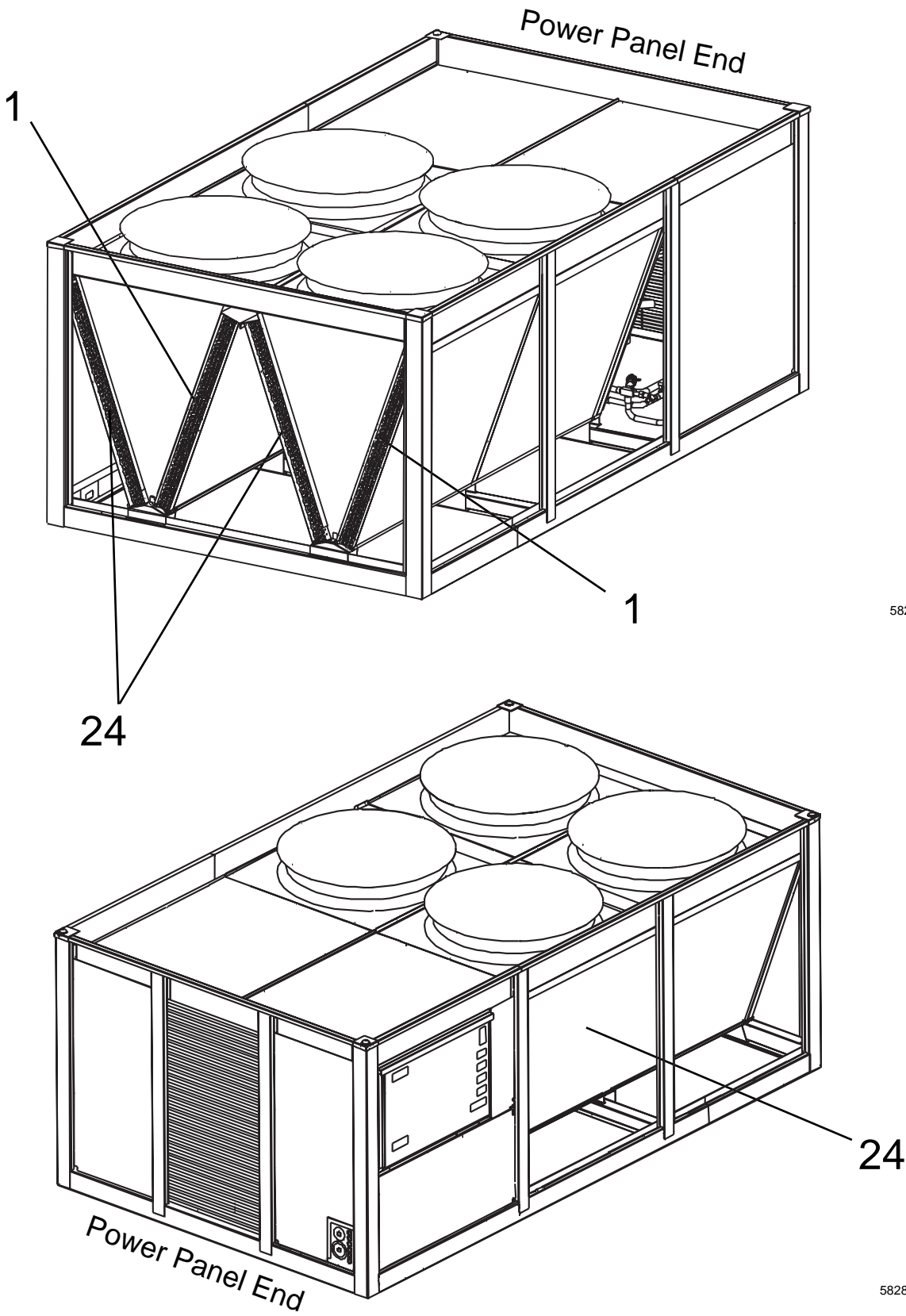

FIG. 2 – CONDENSER COIL LAYOUT (REF. TABLE 2, PAGE 9)

CONDENSOR COIL COMPONENTS (CONT'D)

TABLE 2 – CONDENSER COIL COMPONENTS (SEE FIG. 2, PAGE 8)

ITEM NUMBER	DESCRIPTION	POSITION**	QTY	YCAL0041	YCAL0045	YCAL0051
ALUMINUM FIN COILS						
1	Coil Module*	LH	2	375-58294-202	375-58294-202	375-58294-302
24		RH	2	375-58294-201	375-58294-201	375-58294-301
COPPER COILS						
1	Coil Module*	LH	2	375-58294-212	375-58294-212	375-58294-312
24		RH	2	375-58294-211	375-58294-211	375-58294-311
BLACK FIN COILS						
1	Coil Module*	LH	2	375-58294-222	375-58294-222	375-58294-322
24		RH	2	375-58294-221	375-58294-221	375-58294-321
PHENOLIC COILS						
1	Coil Module*	LH	2	375-58294-232	375-58294-232	375-58294-332
24		RH	2	375-58294-231	375-58294-231	375-58294-331

ITEM NUMBER	DESCRIPTION	POSITION**	QTY	YCAL0055	YCAL0061	YCAL0065
ALUMINUM FIN COILS						
1	Coil Module*	LH	2	375-58294-401	375-58294-504	375-58294-501
24		RH	2	375-58294-402	375-58294-503	375-58294-502
COPPER COILS						
1	Coil Module*	LH	2	375-58294-411	375-58294-514	375-58294-511
24		RH	2	375-58294-412	375-58294-513	375-58294-512
BLACK FIN COILS						
1	Coil Module*	LH	2	375-58294-421	375-58294-524	375-58294-521
24		RH	2	375-58294-422	375-58294-523	375-58294-522
PHENOLIC COILS						
1	Coil Module*	LH	2	375-58294-431	375-58294-534	375-58294-531
24		RH	2	375-58294-432	375-58294-533	375-58294-532

***Note:** Coil Module includes coil and headers.

****Note:** Coils for each circuit are denoted left and right as viewed from the power panel end of chiller.

FAN COMPONENTS

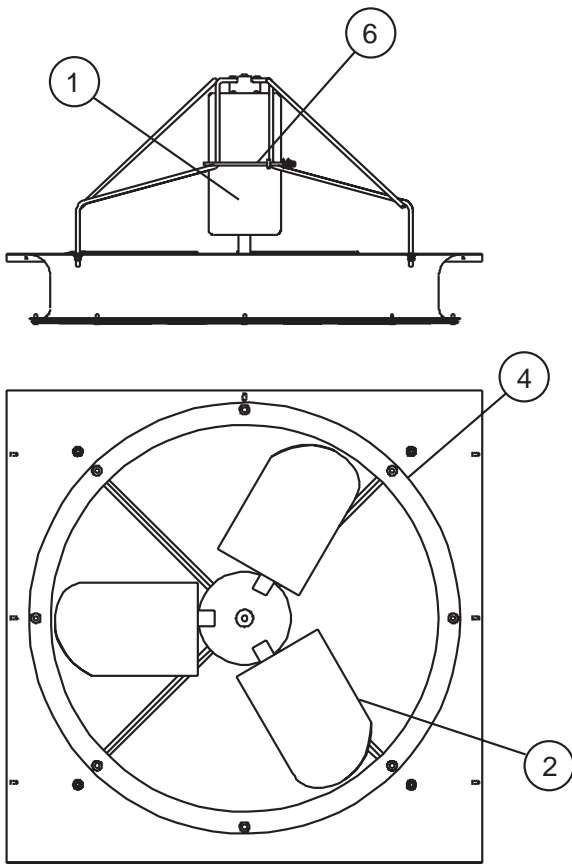

Service Note:

Fan Hub to Shaft Joint should be sealed with protective coating - factory uses RUST VETO 344 - a solvent type, rust preventative coating.

55596-01

Service Note: Pin Location 52 in Model Number will be "X" for Standard Fan, or "L" for Ultra Low Noise Fan. See page 4.

FIG. 3 – FAN COMPONENTS

TABLE 4 – FAN COMPONENTS

ITEM NUMBER	DESCRIPTION	VOLTAGE CODE	FAN TYPE	
			STANDARD 7/8", 1160 RPM	ULTRA LOW NOISE 7/8", 850 RPM
1 ^s	Motor, Fan 2 HP (YCAI0012-YCAL0080)	-17	024-27322-003	024-34980-002
		-28	024-27322-006	024-34980-002
		-40	024-27322-004	024-34980-005
		-46	024-27322-007	024-34980-001
		-50	024-27322-007	024-34980-001
		-58	024-27322-002	024-34980-004
2 ^s	Blade	All	026-41592-000	026-41593-000
3	Guard	All	026-37521-000	
4	Orifice	All	026-42029-000	
5	Support, Fan	All	026-41937-000	026-41938-000
6	Support, Ring	All	026-36367-000	
7	Spacer (.375 I.D.)	All	075-29007-000	
8	Screw, Cap (M8x125)	All	021-18494-000	
9	Spacer (1.406 I.D.)	All	075-40484-000	

^s = Recommended Spare Parts

REFRIGERANT PIPING COMPONENTS CHILLER MODEL YCAL – STYLE 'D'

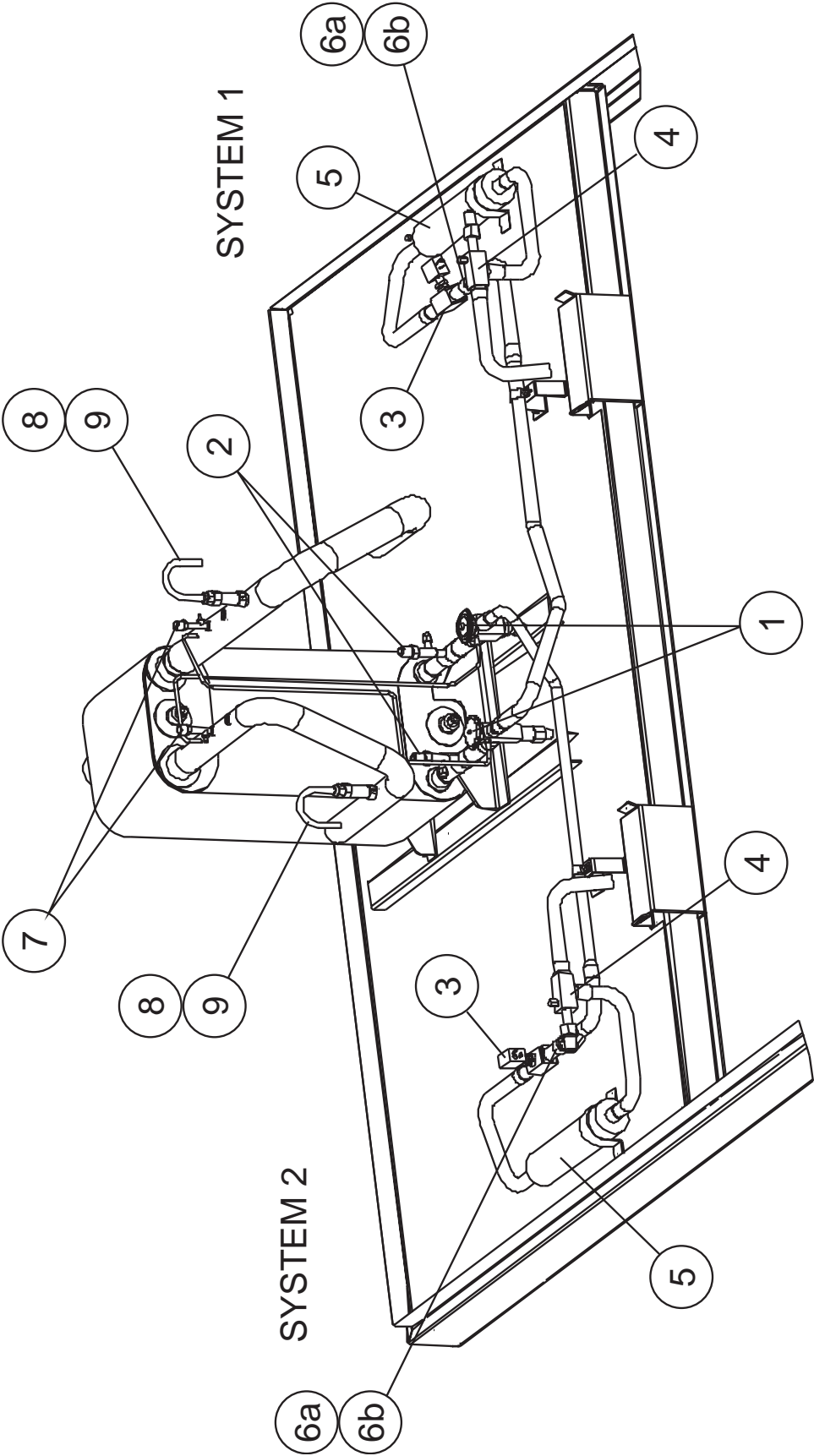

58283-1

SUCTION & LIQUID PIPING

FIG. 4A – REFRIGERANT PIPING COMPONENTS - MODEL YCAL0065 SHOWN (REF. TABLE 5, PAGES 15 AND 16)

REFRIGERANT PIPING COMPONENTS (CONT'D)

CHILLER MODEL YCAL – STYLE 'D'

Piping

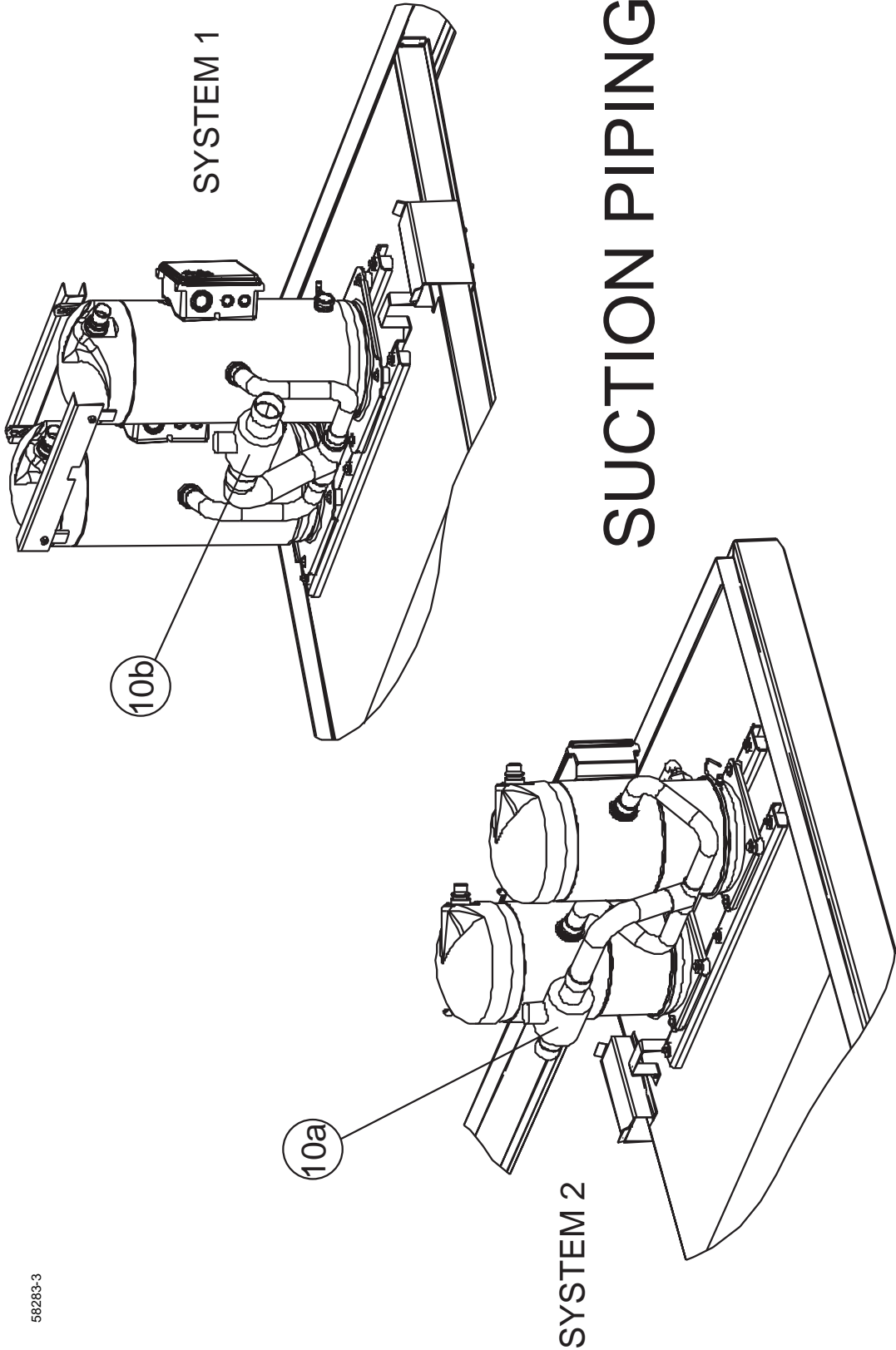

58283-3

FIG. 4B – REFRIGERANT PIPING COMPONENTS - MODEL YCAL0065 SHOWN (REF. TABLE 5, PAGES 15 AND 16)

REFRIGERANT PIPING COMPONENTS (CONT'D)

CHILLER MODEL YCAL – STYLE 'D'

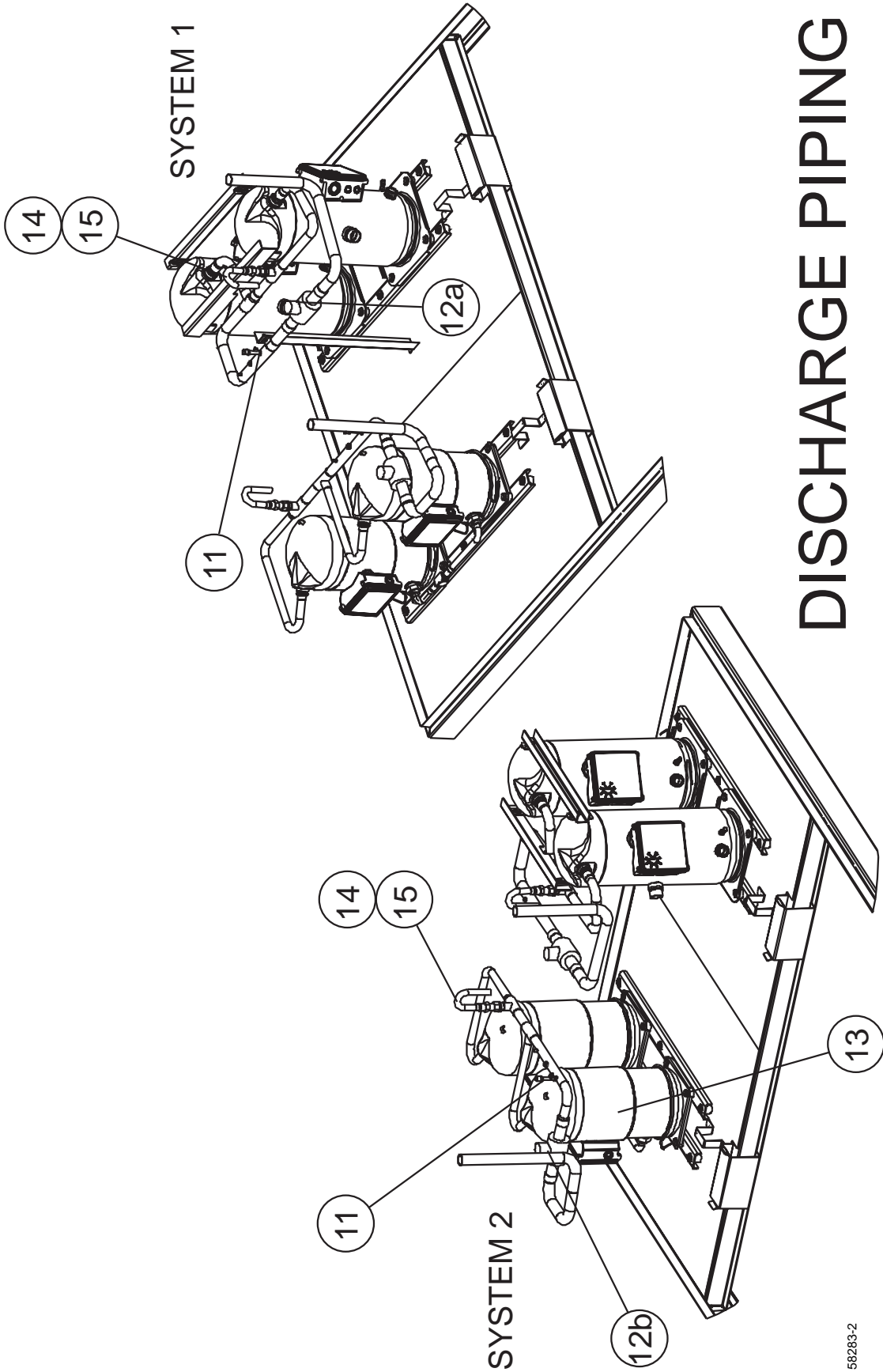

58283-2

FIG. 4C – REFRIGERANT PIPING COMPONENTS - MODEL YCAL0065 SHOWN (REF. TABLE 5, PAGES 15 AND 16)

REFRIGERANT PIPING COMPONENTS (CONT'D)

CHILLER MODEL YCAL – STYLE 'D'

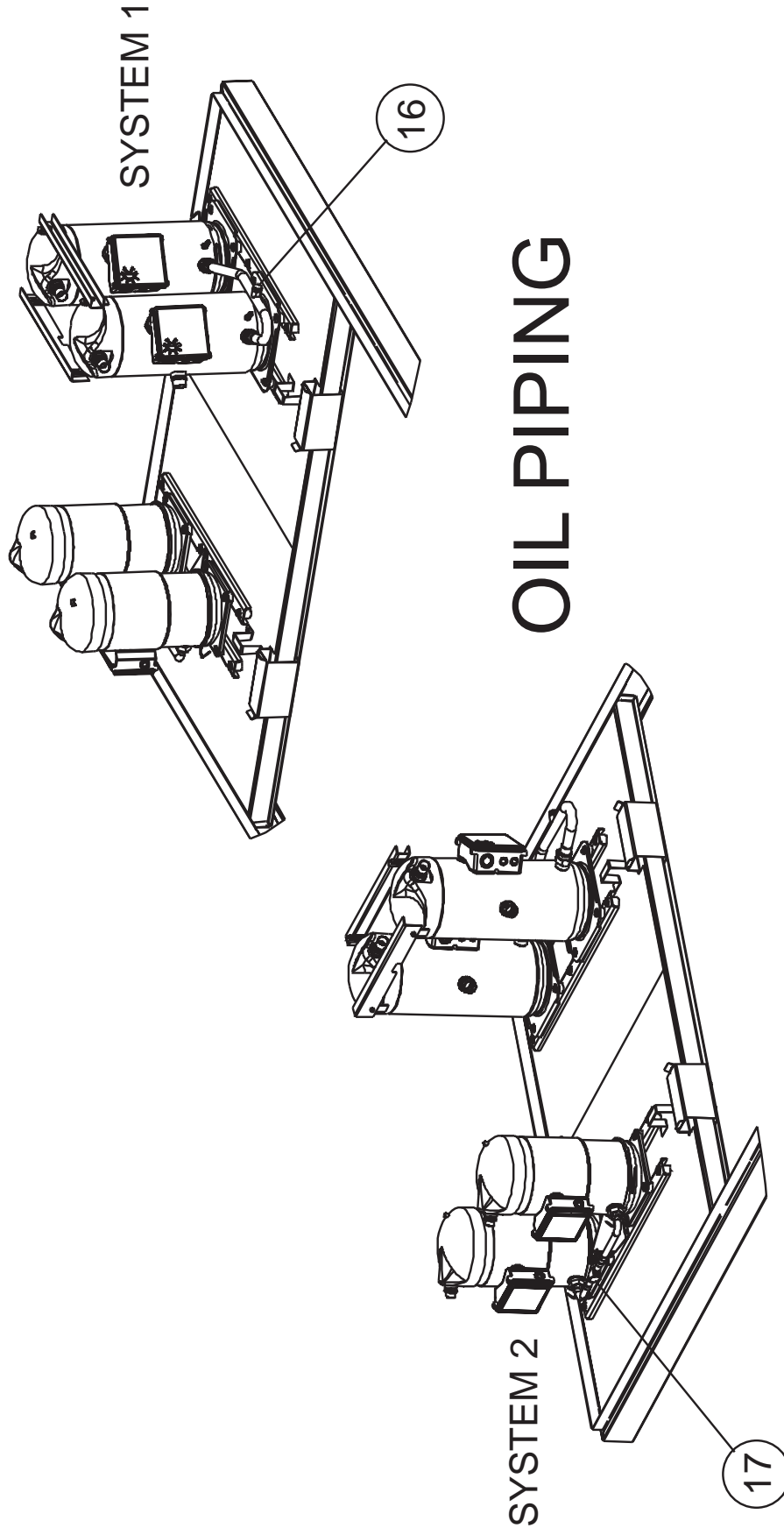

Piping

58283-4

FIG. 4D – REFRIGERANT PIPING COMPONENTS - MODEL YCAL0065 SHOWN (REF. TABLE 5, PAGES 15 AND 16)

REFRIGERANT PIPING COMPONENTS (CONT'D)

CHILLER MODEL YCAL – STYLE 'D'

TABLE 5 – REFRIGERANT PIPING COMPONENTS
(SEE FIGS. 4A, 4B, 4C AND 4D, PAGES 11, 12, 13 AND 14)

ITEM NO.	QTY PER UNIT	DESCRIPTION	SYS.	YCAL0041	YCAL0045	YCAL0051
				375-59430-xxx	375-59425-xxx	375-58510-xxx
1 ^S	2	Valve, Thermal Expansion	Both	025-27535-000	025-27535-000	025-27536-000
2	2	Valve, Liquid Line Charging	Both	022-09754-000	022-09754-000	022-09754-000
3	2	Valve, Liquid Line Solenoid	Both	025-33705-000	025-33705-000	025-33705-000
4	2	Valve, Liquid Line	Both	022-10022-000	022-10022-000	022-10022-000
5	2	Dehydrator	Both	026-20145-000	026-20145-000	026-20145-000
6A	2	Moisture Indicator, Body	Both	026-37548-000	026-37548-000	026-37548-000
6B	2	Moisture Indicator, Sight Glass Cap		026-37544-000	026-37544-000	026-37544-000
7	2	Valve, Suction	Both	022-00009-000	022-00009-000	022-00009-000
8	2	Valve, Suction Relief	Both	022-11386-000	022-11386-000	022-11386-000
9	2	Tube w/ Nut (Use with ITEM 8)	Both	375-37978-000	375-37978-000	375-37978-000
10A	1	Valve, Suction Ball	Sys1	022-09752-000	022-09752-000	022-09752-000
10B	1	Valve, Suction Ball	Sys2			
11	2	Valve, Discharge	Both	022-00009-000	022-00009-000	022-00009-000
12A	1	Valve, Discharge Ball	Sys1	022-09750-000	022-09750-000	022-09750-000
12B	1	Valve, Discharge Ball	Sys2			022-08883-000
13	2	Compressor	Both	See page 19		
14	1	Valve, Discharge Relief	Sys1	022-08863-000	022-08863-000	022-08863-000
	1	Valve, Discharge Relief	Sys2			022-10071-000
15	2	Tube (Use with ITEM 14)	Both	075-30993-000	075-30993-000	075-30993-000
16	1	Moisture Indicator, Body	Sys1	n/a	n/a	026-32398-000
		Moisture Indicator, Sight Glass Cap		n/a	n/a	026-32800-000
17	1	Moisture Indicator, Oil Line	Sys2	n/a	n/a	026-41616-000

^S = Recommended Spare Part

Piping

REFRIGERANT PIPING COMPONENTS (CONT'D)

CHILLER MODEL YCAL – STYLE C

TABLE 5 (CONT'D) – REFRIGERANT PIPING COMPONENTS
(SEE FIGS. 4A, 4B, 4C AND 4D, PAGES 11, 12, 13 AND 14)

ITEM NO.	QTY PER UNIT	DESCRIPTION	SYS.	YCAL0055	YCAL0061	YCAL0065
				375-58485-xxx	375-58497-xxx	375-58283-xxx
1 ^S	1	Valve, Thermal Expansion	Sys1	025-27536-000	025-27536-000	025-27536-000
	1		Sys2		025-20213-000	025-20213-000
2	2	Valve, Liquid Line Charging	Both	022-09754-000	022-09754-000	022-09754-000
3	2	Valve, Liquid Line Solenoid	Both	025-33705-000	025-33705-000	025-40330-000
4	2	Valve, Liquid Line	Both	022-10022-000	022-10022-000	022-10022-000
5	2	Dehydrator	Both	026-20145-000	026-20145-000	026-20145-000
6A	2	Moisture Indicator, Body	Both	026-37548-000	026-37548-000	026-37548-000
6B	2	Moisture Indicator, Sight Glass Cap	Both	026-37544-000	026-37544-000	026-37544-000
7	2	Valve, Suction	Both	022-00009-000	022-00009-000	022-00009-000
8	2	Valve, Suction Relief	Both	022-11386-000	022-11386-000	022-11386-000
9	2	Tube w/ Nut (Use with ITEM 8)	Both	375-37978-000	375-37978-000	375-37978-000
10A	1	Valve, Suction Ball	Sys1	022-09752-000	022-09752-000	022-09752-000
10B	1	Valve, Suction Ball	Sys2		022-09753-000	022-09753-000
11	2	Valve, Discharge	Both	022-00009-000	022-00009-000	022-00009-000
12A	1	Valve, Discharge Ball	Sys1	022-08883-000	022-08883-000	022-08883-000
12B	1	Valve, Discharge Ball	Sys2			
13	2	Compressor	Both	See page 19		
14	2	Valve, Discharge Relief	Both	022-10071-000	022-10071-000	022-10071-000
15	2	Tube (Use with ITEM 14)	Both	075-30993-000	075-30993-000	075-30993-000
16	1	Moisture Indicator, Body	Sys1	026-41616-000	026-41616-000	026-32398-000
		Moisture Indicator, Sight Glass Cap				026-32800-000
17	1	Moisture Indicator	Sys2	026-41616-000	026-41616-000	026-41616-000

^S = Recommended Spare Part

This page intentionally left blank

COMPRESSOR

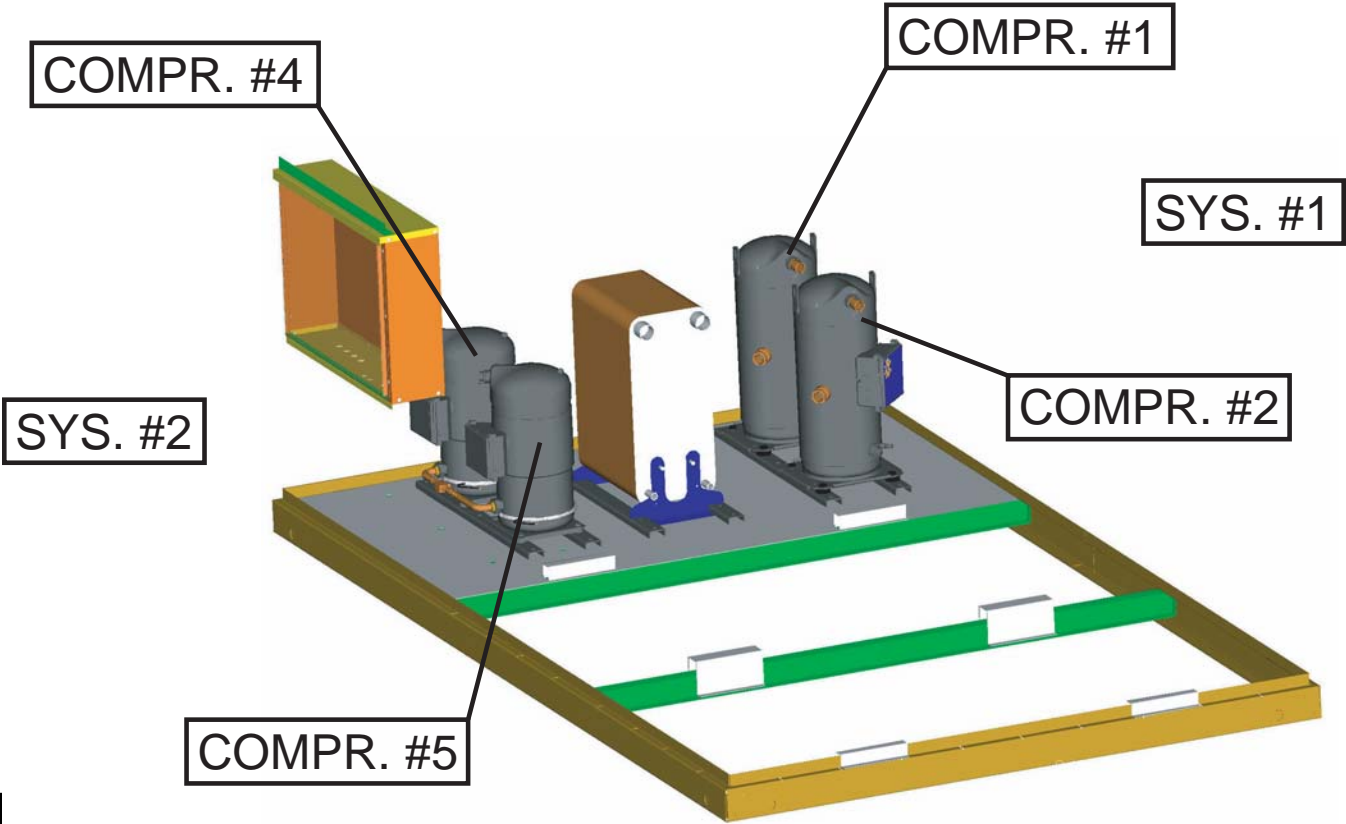

55962-000-A

Compressor

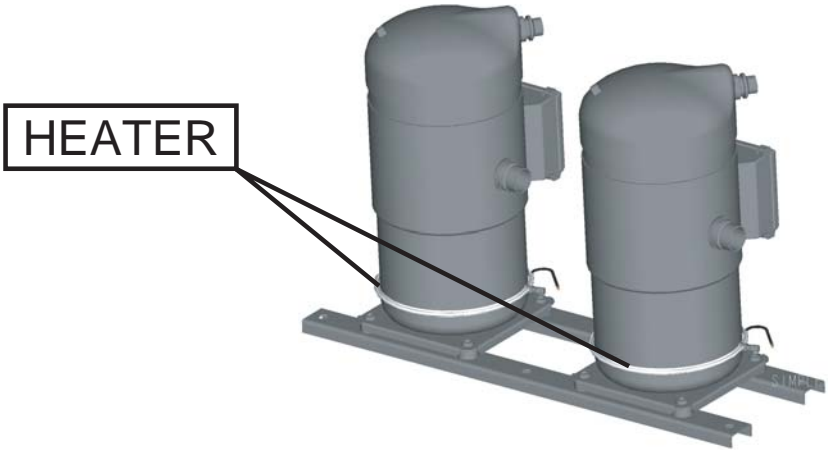

FIG. 5 – COMPRESSOR - TYPICAL LAYOUT (REF. TABLES 6A AND 6B, PAGE 19)

TABLE 6 – RECOMMENDED OIL TYPE

ITEM	COOLANT	DESCRIPTION	1 GALLON	5 GALLON
OIL ^S	R-22	OIL, TYPE 'F' (MINERAL)	n/a	011-00434-000

^S = Recommended Spare Part

COMPRESSOR (CONT'D)

TABLE 6A – R22 COMPRESSOR PART NUMBERS (SEE FIGS. 5, PAGES 18)

MODEL	VOLTAGE CODE	SYSTEM 1		SYSTEM 1		SYSTEM 2		SYSTEM 2	
		#1 COMPRESSOR PART #	MODEL #	#2 COMPRESSOR PART #	MODEL #	#4 COMPRESSOR PART #	MODEL #	#5 COMPRESSOR PART #	MODEL #
YCAV0041	-17 & -28	015-04018-101	ZR125	015-04018-101	ZR125	015-04018-101	ZR125	015-04018-101	ZR125
	-40	015-04018-102	ZR125	015-04018-102	ZR125	015-04018-102	ZR125	015-04018-102	ZR125
	-46 & -50	015-04018-104	ZR125	015-04018-104	ZR125	015-04018-104	ZR125	015-04018-104	ZR125
	-58	015-04018-105	ZR125	015-04018-105	ZR125	015-04018-105	ZR125	015-04018-105	ZR125
YCAV0045	-17 & -28	015-04019-101	ZR144	015-04019-101	ZR144	015-04018-101	ZR125	015-04018-101	ZR125
	-40	015-04019-102	ZR144	015-04019-102	ZR144	015-04018-102	ZR125	015-04018-102	ZR125
	-46 & -50	015-04019-104	ZR144	015-04019-104	ZR144	015-04018-104	ZR125	015-04018-104	ZR125
	-58	015-04019-105	ZR144	015-04019-105	ZR144	015-04018-105	ZR125	015-04018-105	ZR125
YCAV0051	-17 & -28	015-04019-101	ZR144	015-04019-101	ZR144	015-04011-101	ZR16M3	015-04008-101	ZR19M3
	-40	015-04019-102	ZR144	015-04019-102	ZR144	015-04011-102	ZR16M3	015-04008-102	ZR19M3
	-46 & -50	015-04019-104	ZR144	015-04019-104	ZR144	015-04011-104	ZR16M3	015-04008-104	ZR19M3
	-58	015-04019-105	ZR144	015-04019-105	ZR144	015-04011-105	ZR16M3	015-04008-105	ZR19M3
YCAV0055	-17 & -28	015-04008-101	ZR19M3	015-04011-101	ZR19M3	015-04011-101	ZR16M3	015-04008-101	ZR16M3
	-40	015-04008-102	ZR19M3	015-04011-102	ZR19M3	015-04011-102	ZR16M3	015-04008-102	ZR16M3
	-46 & -50	015-04008-104	ZR19M3	015-04011-104	ZR19M3	015-04011-104	ZR16M3	015-04008-104	ZR16M3
	-58	015-04008-105	ZR19M3	015-04011-105	ZR19M3	015-04011-105	ZR16M3	015-04008-105	ZR16M3
YCAV0061	-17 & -28	015-02891-101	ZR250	015-04008-101	ZR250	015-04008-101	ZR19M3	015-04008-101	ZR19M3
	-40	015-02891-102	ZR250	015-04008-102	ZR250	015-04008-102	ZR19M3	015-04008-102	ZR19M3
	-46 & -50	015-02891-104	ZR250	015-04008-104	ZR250	015-04008-104	ZR19M3	015-04008-104	ZR19M3
	-58	015-02891-105	ZR250	015-04008-105	ZR250	015-04008-105	ZR19M3	015-04008-105	ZR19M3
YCAV0065	-17 & -28	015-02891-101	ZR250	015-02891-101	ZR250	015-04008-101	ZR19M3	015-04008-101	ZR19M3
	-40	015-02891-102	ZR250	015-02891-102	ZR250	015-04008-102	ZR19M3	015-04008-102	ZR19M3
	-46 & -50	015-02891-104	ZR250	015-02891-104	ZR250	015-04008-104	ZR19M3	015-04008-104	ZR19M3
	-58	015-02891-105	ZR250	015-02891-105	ZR250	015-04008-105	ZR19M3	015-04008-105	ZR19M3

TABLE 6B – COMPRESSOR HEATER AND COMPRESSOR SOUND BLANKET PART NUMBERS (SEE FIG. 5, PAGE 18)

COMPRESSOR PART NUMBER	HEATER PART NUMBER	QUANTITY PER COMPRESSOR	SOUND BLANKET PART NUMBER	QUANTITY PER COMPRESSOR
015-04018-xxx	025-40351-000	1	010-06507-005	1
015-04019-xxx	025-40351-000	1	010-06507-005	1
015-04008-xxx	025-37888-000	1	010-06507-002	1
015-04011-xxx	025-37888-000	1	010-06507-003	1
015-02891-xxx	025-37852-000	1	010-06507-001	1

Compressor

CONTROL PANEL AND POWER PANEL CONFIGURATIONS

Power panels and option panels are offered in several different configurations using three (3) major components:

1. TERMINAL BLOCKS
2. CIRCUIT BREAKERS
3. NON-FUSED DISCONNECT SWITCHES

The most basic chiller power wiring configuration uses TERMINAL BLOCKS in the power panels, and an options panel with no power wire termination hardware. See figures on previous page. The model pin number locations 16 and 17 would be X and X to reflect this basic combination. Identify model pin number locations 16 and 17 to identify the chiller power wiring connections and hardware listed below.

PIN 16 & 17 LETTER CODE IDENTIFIERS		OPTION PANEL AND POWER PANEL CONFIGURATIONS
S	X	Single Point Supply Terminal Block
S	D	Single Point Supply Non-Fused Disconnect Switch
B	X	Single Point Supply Circuit Breaker

CONTROL PANEL AND POWER PANEL COMPONENTS

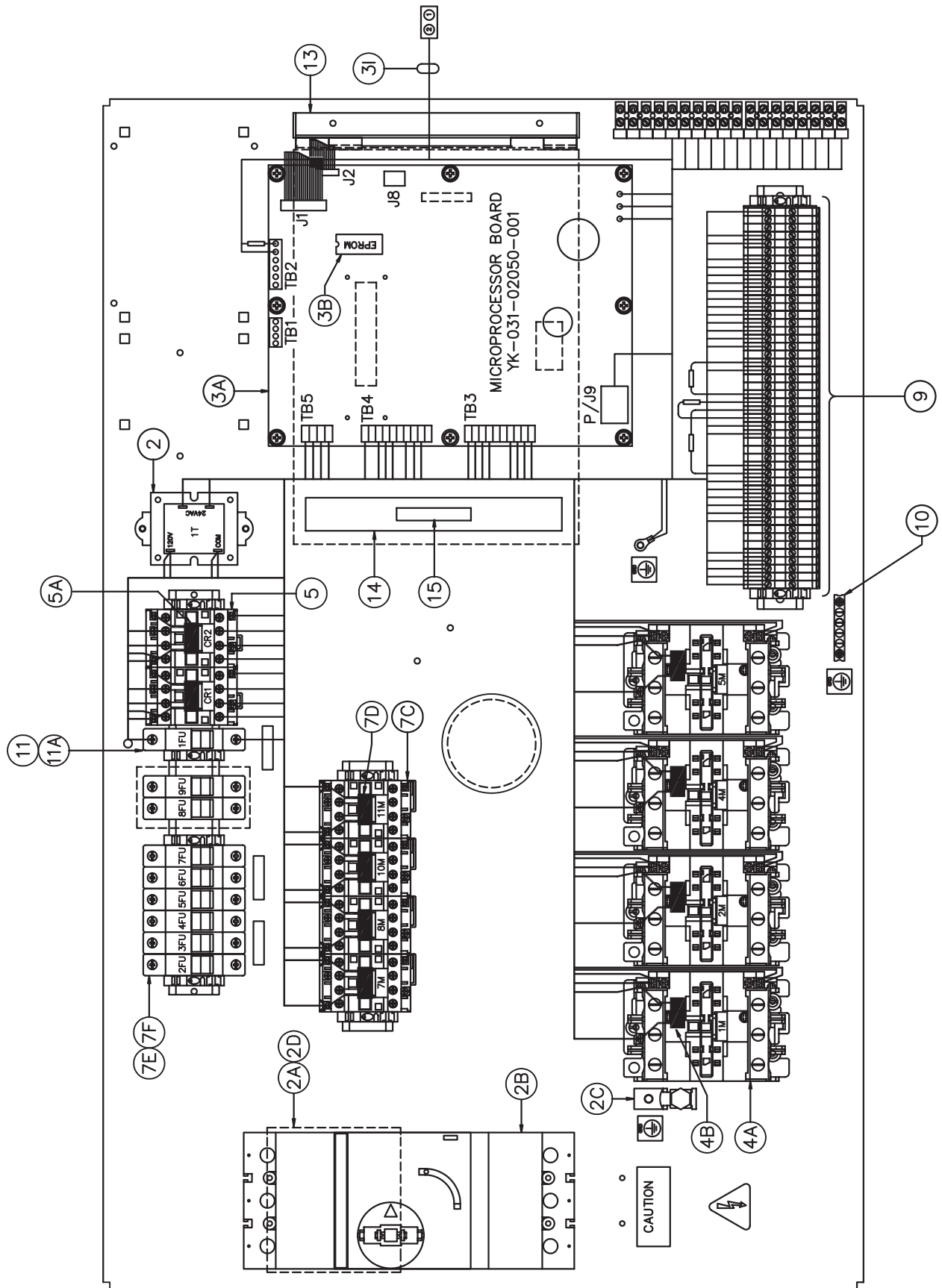

206985-sh11

FIG. 6 – CONTROL AND POWER PANEL COMPONENTS (REF. TABLE 8, PAGES 24-32)

Control & Power Panel

CONTROL PANEL AND POWER PANEL COMPONENTS (CONT'D)

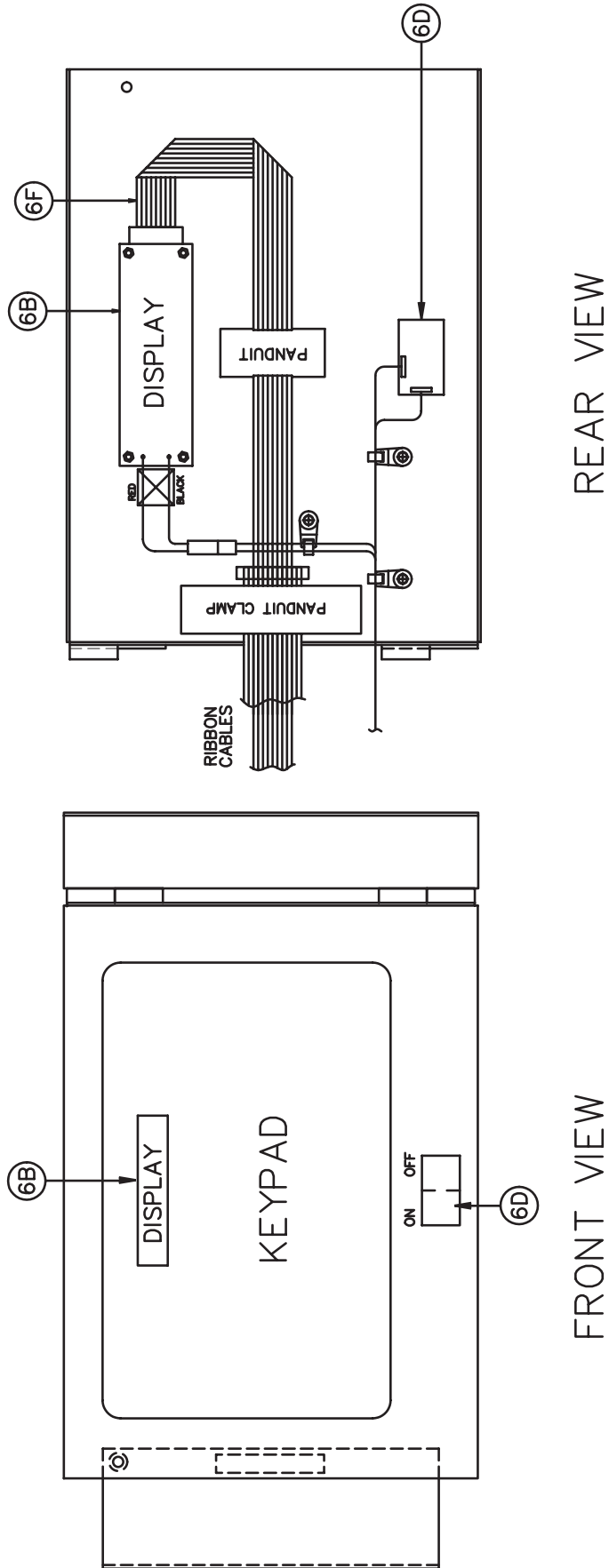

202777-3

FIG. 6A – CONTROL AND POWER PANEL COMPONENTS (REF. TABLE 8, PAGES 24-32)

CONTROL PANEL AND POWER PANEL COMPONENTS (CONT'D)

TABLE 7 – CONTROL AND POWER PANEL IDENTIFIERS (TO IDENTIFY REPLACEMENT PART NUMBERS, SELECT PANEL IDENTIFIER NUMBER BELOW, THEN REFER TO THE HIGHLIGHTED ROW ON THE 'CONTROL AND POWER PANEL COMPONENTS' TABLE 8, PAGES 24-32 AND SEE FIGS. 6 AND 6A, PAGES 21 AND 22)

MODEL	VOLTAGE CODE	SINGLE POINT TERMINAL BLOCK (SX)	SINGLE POINT NON-FUSED DISCONNECT SWITCH (SD)	SINGLE POINT CIRCUIT BREAKER (BX)
YCAL0041	17 & 28	371-04537-103	371-04537-203	371-04537-303
	40	371-04537-102	371-04537-202	371-04537-302
	46, 50 & 58	371-04537-101	371-04537-201	371-04537-301
YCAL0045	17 & 28	371-04537-103	371-04537-203	371-04537-303
	40	371-04537-102	371-04537-202	371-04537-302
	46, 50 & 58	371-04537-101	371-04537-201	371-04537-301
YCAL0051	17 & 28	371-04537-104	371-04537-204	371-04537-304
	40, 46 & 50	371-04537-102	371-04537-202	371-04537-302
	58	371-04537-101	371-04537-201	371-04537-301
YCAL0055	17 & 28	371-04537-104	371-04537-204	371-04537-304
	40, 46 & 50	371-04537-102	371-04537-202	371-04537-302
	58	371-04537-102	371-04537-202	371-04537-302
YCAL0061	17 & 28	371-04537-105	371-04537-205	371-04537-305
	40	371-04537-103	371-04537-203	371-04537-303
	46, 50 & 58	371-04537-102	371-04537-202	371-04537-302
YCAL0065	17 & 28	371-04537-105	371-04537-205	371-04537-305
	40	371-04537-103	371-04537-203	371-04537-303
	46, 50 & 58	371-04537-102	371-04537-202	371-04537-302

CONTROL PANEL AND POWER PANEL COMPONENTS (CONT'D)

TABLE 8 – CONTROL AND POWER PANEL COMPONENTS (SEE FIGS. 6 AND 6A, PAGES 21 AND 22)

Item	Qty	Description	YCAL0041-17 & YCAL0041-28			YCAL0041-40		
			371-04537-103* SX	371-04537-203* SD	371-04537-303* BX	371-04537-102* SX	371-04537-202* SD	371-04537-302* BX
2	1	Control Transformer	025-30889-000	025-30889-000	025-30889-000	025-30889-000	025-30889-000	025-30889-000
2A	1	Single Point Terminal Block	025-39386-000	N/A	N/A	025-39386-000	N/A	N/A
	1	Single Point Circuit Breaker	N/A	N/A	025-34419-000	N/A	N/A	025-34419-000
	1	Single Point NF Disconnect Switch	N/A	024-31870-000	N/A	N/A	024-31888-000	N/A
2B	1	Lugs	N/A	025-34480-000	025-34418-000	N/A	025-34480-000	025-34418-000
2C	1	Ground Lug	025-34089-000	025-34089-000	025-34089-000	025-34089-000	025-34089-000	025-34089-000
2D	3	Safety Cover	025-39393-000	N/A	N/A	025-39393-000	N/A	N/A
3A	1	Control Board	031-02050-001	031-02050-001	031-02050-001	031-02050-001	031-02050-001	031-02050-001
3B	1	Eprom	031-02049-001	031-02049-001	031-02049-001	031-02049-001	031-02049-001	031-02049-001
4A	4	Compressor Contactor	024-35467-000	024-35467-000	024-35467-000	024-35462-000	024-35462-000	024-35462-000
4B	4	Surge Suppressor	031-00808-000	031-00808-000	031-00808-000	031-00808-000	031-00808-000	031-00808-000
4D	4	Auxiliary Contact	024-35493-000	N/A	N/A	N/A	N/A	N/A
5	2	Control Relay	024-35526-000	024-35526-000	024-35526-000	024-35526-000	024-35526-000	024-35526-000
5A	2	Surge Suppressor	031-00808-000	031-00808-000	031-00808-000	031-00808-000	031-00808-000	031-00808-000
6B	1	Display	031-02100-000	031-02100-000	031-02100-000	031-02100-000	031-02100-000	031-02100-000
6D	1	Switch	024-25517-000	024-25517-000	024-25517-000	024-25517-000	024-25517-000	024-25517-000
6F	1	Ribbon Cable	031-01109-211	031-01109-211	031-01109-211	031-01109-211	031-01109-211	031-01109-211
7C	4	Fan Contactor	024-35444-000	024-35444-000	024-35441-000	024-35441-000	024-35441-000	024-35441-000
7D	4	Surge Suppressor	031-00808-000	031-00808-000	031-00808-000	031-00808-000	031-00808-000	031-00808-000
7E	2	Fuse Block	025-37863-000	025-37863-000	025-37863-000	025-37863-000	025-37863-000	025-37863-000
7F	6	Fuse	025-34142-000	025-34142-000	025-34142-000	025-34142-000	025-34142-000	025-34142-000
10	1	Ground Bar	025-35685-000	025-35685-000	025-35685-000	025-35685-000	025-35685-000	025-35685-000
11	1	Fuse Block	025-37862-000	025-37862-000	025-37862-000	025-37862-000	025-37862-000	025-37862-000
11A	1	Fuse	025-34435-000	025-34435-000	025-34435-000	025-34435-000	025-34435-000	025-34435-000

^S = Recommended Spare Part

SX*	SINGLE POINT TERMINAL BLOCK
SD*	SINGLE POINT NON-FUSED DISCONNECT SWITCH
BX*	SINGLE POINT CIRCUIT BREAKER

***Service Note:**

Locate the PANEL NUMBER sticker on the upper right hand corner of the power panel, then refer to the appropriate parts list for that number. Or, identify PIN number positions 16 and 17 on unit identification plate (See example on Page 4) then compare to table at right for power configuration options.

CONTROL PANEL AND POWER PANEL COMPONENTS (CONT'D)

TABLE 8 – CONTROL AND POWER PANEL COMPONENTS (SEE FIGS. 6 AND 6A, PAGES 21 AND 22)

Item	Qty	Description	YCAL0041-46, YCAL0041-50 & YCAL0041-58			YCAL0045-17 & YCAL0045-28		
			371-04537-101* SX	371-04537-201* SD	371-04537-301* BX	371-04537-103* SX	371-04537-203* SD	371-04537-303* BX
2	1	Control Transformer	025-30889-000	025-30889-000	025-30889-000	025-30889-000	025-30889-000	025-30889-000
2A	1	Single Point Terminal Block	025-39386-000	N/A	N/A	025-39386-000	N/A	N/A
	1	Single Point Circuit Breaker	N/A	N/A	025-34419-000	N/A	N/A	025-34419-000
	1	Single Point NF Disconnect Switch	N/A	024-31888-000	N/A	N/A	024-31870-000	N/A
2B	1	Lugs	N/A	025-34480-000	025-34418-000	N/A	025-34480-000	025-34418-000
2C	1	Ground Lug	025-34089-000	025-34089-000	025-34089-000	025-34089-000	025-34089-000	025-34089-000
2D	3	Safety Cover	025-39393-000	N/A	N/A	025-39393-000	N/A	N/A
3A	1	Control Board	031-02050-001	031-02050-001	031-02050-001	031-02050-001	031-02050-001	031-02050-001
3B	1	Eprom	031-02049-001	031-02049-001	031-02049-001	031-02049-001	031-02049-001	031-02049-001
4A	4	Compressor Contactor	024-35454-000	024-35454-000	024-35454-000	024-35467-000	024-35467-000	024-35467-000
4B	4	Surge Suppressor	031-00808-000	031-00808-000	031-00808-000	031-00808-000	031-00808-000	031-00808-000
4D	4	Auxiliary Contact	024-35493-000	024-35493-000	024-35493-000	024-35493-000	N/A	N/A
5	2	Control Relay	024-35526-000	024-35526-000	024-35526-000	024-35526-000	024-35526-000	024-35526-000
5A	2	Surge Suppressor	031-00808-000	031-00808-000	031-00808-000	031-00808-000	031-00808-000	031-00808-000
6B	1	Display	031-02100-000	031-02100-000	031-02100-000	031-02100-000	031-02100-000	031-02100-000
6D	1	Switch	024-25517-000	024-25517-000	024-25517-000	024-25517-000	024-25517-000	024-25517-000
6F	1	Ribbon Cable	031-01109-211	031-01109-211	031-01109-211	031-01109-211	031-01109-211	031-01109-211
7C	4	Fan Contactor	024-35441-000	024-35441-000	024-35441-000	024-35444-000	024-35444-000	024-35441-000
7D	4	Surge Suppressor	031-00808-000	031-00808-000	031-00808-000	031-00808-000	031-00808-000	031-00808-000
7E	2	Fuse Block	025-37863-000	025-37863-000	025-37863-000	025-37863-000	025-37863-000	025-37863-000
7F	6	Fuse	025-34142-000	025-34142-000	025-34142-000	025-34142-000	025-34142-000	025-34142-000
10	1	Ground Bar	025-35685-000	025-35685-000	025-35685-000	025-35685-000	025-35685-000	025-35685-000
11	1	Fuse Block	025-37862-000	025-37862-000	025-37862-000	025-37862-000	025-37862-000	025-37862-000
11A	1	Fuse	025-34435-000	025-34435-000	025-34435-000	025-34435-000	025-34435-000	025-34435-000

^S = Recommended Spare Part

SX*	SINGLE POINT TERMINAL BLOCK
SD*	SINGLE POINT NON-FUSED DISCONNECT SWITCH
BX*	SINGLE POINT CIRCUIT BREAKER

***Service Note:**

Locate the PANEL NUMBER sticker on the upper right hand corner of the power panel, then refer to the appropriate parts list for that number. Or, identify PIN number positions 16 and 17 on unit identification plate (See example on Page 4) then compare to table at right for power configuration options.

CONTROL PANEL AND POWER PANEL COMPONENTS (CONT'D)

TABLE 8 – CONTROL AND POWER PANEL COMPONENTS (SEE FIGS. 6 AND 6A, PAGES 21 AND 22)

Item	Qty	Description	YCAL0045-40			YCAL0045-46, YCAL0045-50 & YCAL0045-58		
			371-04537-101* SX	371-04537-201* SD	371-04537-301* BX	371-04537-103* SX	371-04537-203* SD	371-04537-303* BX
2	1	Control Transformer	025-30889-000	025-30889-000	025-30889-000	025-30889-000	025-30889-000	025-30889-000
2A	1	Single Point Terminal Block	025-39386-000	N/A	N/A	025-39386-000	N/A	N/A
	1	Single Point Circuit Breaker	N/A	N/A	025-34419-000	N/A	N/A	025-34419-000
	1	Single Point NF Disconnect Switch	N/A	024-31888-000	N/A	N/A	024-31870-000	N/A
2B	1	Lugs	N/A	025-34480-000	025-34418-000	N/A	025-34480-000	025-34418-000
2C	1	Ground Lug	025-34089-000	025-34089-000	025-34089-000	025-34089-000	025-34089-000	025-34089-000
2D	3	Safety Cover	025-39393-000	N/A	N/A	025-39393-000	N/A	N/A
3A	1	Control Board	031-02050-001	031-02050-001	031-02050-001	031-02050-001	031-02050-001	031-02050-001
3B	1	Eprom	031-02049-001	031-02049-001	031-02049-001	031-02049-001	031-02049-001	031-02049-001
4A	4	Compressor Contactor	024-35454-000	024-35454-000	024-35454-000	024-35467-000	024-35467-000	024-35467-000
4B	4	Surge Suppressor	031-00808-000	031-00808-000	031-00808-000	031-00808-000	031-00808-000	031-00808-000
4D	4	Auxiliary Contact	024-35493-000	024-35493-000	024-35493-000	024-35493-000	N/A	N/A
5	2	Control Relay	024-35526-000	024-35526-000	024-35526-000	024-35526-000	024-35526-000	024-35526-000
5A	2	Surge Suppressor	031-00808-000	031-00808-000	031-00808-000	031-00808-000	031-00808-000	031-00808-000
6B	1	Display	031-02100-000	031-02100-000	031-02100-000	031-02100-000	031-02100-000	031-02100-000
6D	1	Switch	024-25517-000	024-25517-000	024-25517-000	024-25517-000	024-25517-000	024-25517-000
6F	1	Ribbon Cable	031-01109-211	031-01109-211	031-01109-211	031-01109-211	031-01109-211	031-01109-211
7C	4	Fan Contactor	024-35441-000	024-35441-000	024-35441-000	024-35444-000	024-35444-000	024-35441-000
7D	4	Surge Suppressor	031-00808-000	031-00808-000	031-00808-000	031-00808-000	031-00808-000	031-00808-000
7E	2	Fuse Block	025-37863-000	025-37863-000	025-37863-000	025-37863-000	025-37863-000	025-37863-000
7F	6	Fuse	025-34142-000	025-34142-000	025-34142-000	025-34142-000	025-34142-000	025-34142-000
10	1	Ground Bar	025-35685-000	025-35685-000	025-35685-000	025-35685-000	025-35685-000	025-35685-000
11	1	Fuse Block	025-37862-000	025-37862-000	025-37862-000	025-37862-000	025-37862-000	025-37862-000
11A	1	Fuse	025-34435-000	025-34435-000	025-34435-000	025-34435-000	025-34435-000	025-34435-000

^S = Recommended Spare Part

SX*	SINGLE POINT TERMINAL BLOCK
SD*	SINGLE POINT NON-FUSED DISCONNECT SWITCH
BX*	SINGLE POINT CIRCUIT BREAKER

***Service Note:**

Locate the PANEL NUMBER sticker on the upper right hand corner of the power panel, then refer to the appropriate parts list for that number. Or, identify PIN number positions 16 and 17 on unit identification plate (See example on Page 4) then compare to table at right for power configuration options.

CONTROL PANEL AND POWER PANEL COMPONENTS (CONT'D)

TABLE 8 – CONTROL AND POWER PANEL COMPONENTS (SEE FIGS. 6 AND 6A, PAGES 21 AND 22)

Item	Qty	Description	YCAL0051-17 & YCAL0051-28			YCAL0051-40, YCAL0051-46 & YCAL0051-50		
			371-04537-103* SX	371-04537-203* SD	371-04537-303* BX	371-04537-102* SX	371-04537-202* SD	371-04537-302* BX
2	1	Control Transformer	025-30889-000	025-30889-000	025-30889-000	025-30889-000	025-30889-000	025-30889-000
2A	1	Single Point Terminal Block	025-39386-000	N/A	N/A	025-39386-000	N/A	N/A
	1	Single Point Circuit Breaker	N/A	N/A	025-34419-000	N/A	N/A	025-34419-000
	1	Single Point NF Disconnect Switch	N/A	024-31870-000	N/A	N/A	024-31888-000	N/A
2B	1	Lugs	N/A	025-34480-000	025-34418-000	N/A	025-34480-000	025-34418-000
2C	1	Ground Lug	025-34089-000	025-34089-000	025-34089-000	025-34089-000	025-34089-000	025-34089-000
2D	3	Safety Cover	025-39393-000	N/A	N/A	025-39393-000	N/A	N/A
3A	1	Control Board	031-02050-001	031-02050-001	031-02050-001	031-02050-001	031-02050-001	031-02050-001
3B	1	Eprom	031-02049-001	031-02049-001	031-02049-001	031-02049-001	031-02049-001	031-02049-001
4A	4	Compressor Contactor	024-35467-000	024-35467-000	024-35467-000	024-35462-000	024-35462-000	024-35462-000
4B	4	Surge Suppressor	031-00808-000	031-00808-000	031-00808-000	031-00808-000	031-00808-000	031-00808-000
4D	4	Auxiliary Contact	024-35493-000	N/A	N/A	N/A	N/A	N/A
5	2	Control Relay	024-35526-000	024-35526-000	024-35526-000	024-35526-000	024-35526-000	024-35526-000
5A	2	Surge Suppressor	031-00808-000	031-00808-000	031-00808-000	031-00808-000	031-00808-000	031-00808-000
6B	1	Display	031-02100-000	031-02100-000	031-02100-000	031-02100-000	031-02100-000	031-02100-000
6D	1	Switch	024-25517-000	024-25517-000	024-25517-000	024-25517-000	024-25517-000	024-25517-000
6F	1	Ribbon Cable	031-01109-211	031-01109-211	031-01109-211	031-01109-211	031-01109-211	031-01109-211
7C	4	Fan Contactor	024-35444-000	024-35444-000	024-35441-000	024-35441-000	024-35441-000	024-35441-000
7D	4	Surge Suppressor	031-00808-000	031-00808-000	031-00808-000	031-00808-000	031-00808-000	031-00808-000
7E	2	Fuse Block	025-37863-000	025-37863-000	025-37863-000	025-37863-000	025-37863-000	025-37863-000
7F	6	Fuse	025-34142-000	025-34142-000	025-34142-000	025-34142-000	025-34142-000	025-34142-000
10	1	Ground Bar	025-35685-000	025-35685-000	025-35685-000	025-35685-000	025-35685-000	025-35685-000
11	1	Fuse Block	025-37862-000	025-37862-000	025-37862-000	025-37862-000	025-37862-000	025-37862-000
11A	1	Fuse	025-34435-000	025-34435-000	025-34435-000	025-34435-000	025-34435-000	025-34435-000

^S = Recommended Spare Part

SX*	SINGLE POINT TERMINAL BLOCK
SD*	SINGLE POINT NON-FUSED DISCONNECT SWITCH
BX*	SINGLE POINT CIRCUIT BREAKER

***Service Note:**

Locate the PANEL NUMBER sticker on the upper right hand corner of the power panel, then refer to the appropriate parts list for that number. Or, identify PIN number positions 16 and 17 on unit identification plate (See example on Page 4) then compare to table at right for power configuration options.

CONTROL PANEL AND POWER PANEL COMPONENTS (CONT'D)

TABLE 8 – CONTROL AND POWER PANEL COMPONENTS (SEE FIGS. 6 AND 6A, PAGES 21 AND 22)

Item	Qty	Description	YCAL0051-58			YCAL0055-17 & YCAL0055-28		
			371-04537-101* SX	371-04537-201* SD	371-04537-301* BX	371-04537-103* SX	371-04537-203* SD	371-04537-303* BX
2	1	Control Transformer	025-30889-000	025-30889-000	025-30889-000	025-30889-000	025-30889-000	025-30889-000
2A	1	Single Point Terminal Block	025-39386-000	N/A	N/A	025-39386-000	N/A	N/A
	1	Single Point Circuit Breaker	N/A	N/A	025-34419-000	N/A	N/A	025-34419-000
	1	Single Point NF Disconnect Switch	N/A	024-31888-000	N/A	N/A	024-31870-000	N/A
2B	1	Lugs	N/A	025-34480-000	025-34418-000	N/A	025-34480-000	025-34418-000
2C	1	Ground Lug	025-34089-000	025-34089-000	025-34089-000	025-34089-000	025-34089-000	025-34089-000
2D	3	Safety Cover	025-39393-000	N/A	N/A	025-39393-000	N/A	N/A
3A	1	Control Board	031-02050-001	031-02050-001	031-02050-001	031-02050-001	031-02050-001	031-02050-001
3B	1	Eprom	031-02049-001	031-02049-001	031-02049-001	031-02049-001	031-02049-001	031-02049-001
4A	4	Compressor Contactor	024-35454-000	024-35454-000	024-35454-000	024-35467-000	024-35467-000	024-35467-000
4B	4	Surge Suppressor	031-00808-000	031-00808-000	031-00808-000	031-00808-000	031-00808-000	031-00808-000
4D	4	Auxiliary Contact	024-35493-000	024-35493-000	024-35493-000	024-35493-000	N/A	N/A
5	2	Control Relay	024-35526-000	024-35526-000	024-35526-000	024-35526-000	024-35526-000	024-35526-000
5A	2	Surge Suppressor	031-00808-000	031-00808-000	031-00808-000	031-00808-000	031-00808-000	031-00808-000
6B	1	Display	031-02100-000	031-02100-000	031-02100-000	031-02100-000	031-02100-000	031-02100-000
6D	1	Switch	024-25517-000	024-25517-000	024-25517-000	024-25517-000	024-25517-000	024-25517-000
6F	1	Ribbon Cable	031-01109-211	031-01109-211	031-01109-211	031-01109-211	031-01109-211	031-01109-211
7C	4	Fan Contactor	024-35441-000	024-35441-000	024-35441-000	024-35444-000	024-35444-000	024-35441-000
7D	4	Surge Suppressor	031-00808-000	031-00808-000	031-00808-000	031-00808-000	031-00808-000	031-00808-000
7E	2	Fuse Block	025-37863-000	025-37863-000	025-37863-000	025-37863-000	025-37863-000	025-37863-000
7F	6	Fuse	025-34142-000	025-34142-000	025-34142-000	025-34142-000	025-34142-000	025-34142-000
10	1	Ground Bar	025-35685-000	025-35685-000	025-35685-000	025-35685-000	025-35685-000	025-35685-000
11	1	Fuse Block	025-37862-000	025-37862-000	025-37862-000	025-37862-000	025-37862-000	025-37862-000
11A	1	Fuse	025-34435-000	025-34435-000	025-34435-000	025-34435-000	025-34435-000	025-34435-000

^S = Recommended Spare Part

SX*	SINGLE POINT TERMINAL BLOCK
SD*	SINGLE POINT NON-FUSED DISCONNECT SWITCH
BX*	SINGLE POINT CIRCUIT BREAKER

***Service Note:**

Locate the PANEL NUMBER sticker on the upper right hand corner of the power panel, then refer to the appropriate parts list for that number. Or, identify PIN number positions 16 and 17 on unit identification plate (See example on Page 4) then compare to table at right for power configuration options.

CONTROL PANEL AND POWER PANEL COMPONENTS (CONT'D)

TABLE 8 – CONTROL AND POWER PANEL COMPONENTS (SEE FIGS. 6 AND 6A, PAGES 21 AND 22)

Item	Qty	Description	YCAL0055-40, YCAL0055-46, YCAL0055-50 & YCAL0055-58			YCAL0061-17 & YCAL0061-28		
			371-04537-103* SX	371-04537-203* SD	371-04537-303* BX	371-04537-102* SX	371-04537-202* SD	371-04537-302* BX
2	1	Control Transformer	025-30889-000	025-30889-000	025-30889-000	025-30889-000	025-30889-000	025-30889-000
2A	1	Single Point Terminal Block	025-39386-000	N/A	N/A	025-39386-000	N/A	N/A
	1	Single Point Circuit Breaker	N/A	N/A	025-34419-000	N/A	N/A	025-34419-000
	1	Single Point NF Disconnect Switch	N/A	024-31870-000	N/A	N/A	024-31888-000	N/A
2B	1	Lugs	N/A	025-34480-000	025-34418-000	N/A	025-34480-000	025-34418-000
2C	1	Ground Lug	025-34089-000	025-34089-000	025-34089-000	025-34089-000	025-34089-000	025-34089-000
2D	3	Safety Cover	025-39393-000	N/A	N/A	025-39393-000	N/A	N/A
3A	1	Control Board	031-02050-001	031-02050-001	031-02050-001	031-02050-001	031-02050-001	031-02050-001
3B	1	Eprom	031-02049-001	031-02049-001	031-02049-001	031-02049-001	031-02049-001	031-02049-001
4A	4	Compressor Contactor	024-35467-000	024-35467-000	024-35467-000	024-35462-000	024-35462-000	024-35462-000
4B	4	Surge Suppressor	031-00808-000	031-00808-000	031-00808-000	031-00808-000	031-00808-000	031-00808-000
4D	4	Auxiliary Contact	024-35493-000	N/A	N/A	N/A	N/A	N/A
5	2	Control Relay	024-35526-000	024-35526-000	024-35526-000	024-35526-000	024-35526-000	024-35526-000
5A	2	Surge Suppressor	031-00808-000	031-00808-000	031-00808-000	031-00808-000	031-00808-000	031-00808-000
6B	1	Display	031-02100-000	031-02100-000	031-02100-000	031-02100-000	031-02100-000	031-02100-000
6D	1	Switch	024-25517-000	024-25517-000	024-25517-000	024-25517-000	024-25517-000	024-25517-000
6F	1	Ribbon Cable	031-01109-211	031-01109-211	031-01109-211	031-01109-211	031-01109-211	031-01109-211
7C	4	Fan Contactor	024-35444-000	024-35444-000	024-35441-000	024-35441-000	024-35441-000	024-35441-000
7D	4	Surge Suppressor	031-00808-000	031-00808-000	031-00808-000	031-00808-000	031-00808-000	031-00808-000
7E	2	Fuse Block	025-37863-000	025-37863-000	025-37863-000	025-37863-000	025-37863-000	025-37863-000
7F	6	Fuse	025-34142-000	025-34142-000	025-34142-000	025-34142-000	025-34142-000	025-34142-000
10	1	Ground Bar	025-35685-000	025-35685-000	025-35685-000	025-35685-000	025-35685-000	025-35685-000
11	1	Fuse Block	025-37862-000	025-37862-000	025-37862-000	025-37862-000	025-37862-000	025-37862-000
11A	1	Fuse	025-34435-000	025-34435-000	025-34435-000	025-34435-000	025-34435-000	025-34435-000

S = Recommended Spare Part

SX*	SINGLE POINT TERMINAL BLOCK
SD*	SINGLE POINT NON-FUSED DISCONNECT SWITCH
BX*	SINGLE POINT CIRCUIT BREAKER

***Service Note:**

Locate the PANEL NUMBER sticker on the upper right hand corner of the power panel, then refer to the appropriate parts list for that number. Or, identify PIN number positions 16 and 17 on unit identification plate (See example on Page 4) then compare to table at right for power configuration options.

CONTROL PANEL AND POWER PANEL COMPONENTS (CONT'D)

TABLE 8 – CONTROL AND POWER PANEL COMPONENTS (SEE FIGS. 6 AND 6A, PAGES 21 AND 22)

Item	Qty	Description	YCAL0061-40			YCAL0061-46, YCAL0061-50 & YCAL0061-58		
			371-04537-101* SX	371-04537-201* SD	371-04537-301* BX	371-04537-103* SX	371-04537-203* SD	371-04537-303* BX
2	1	Control Transformer	025-30889-000	025-30889-000	025-30889-000	025-30889-000	025-30889-000	025-30889-000
2A	1	Single Point Terminal Block	025-39386-000	N/A	N/A	025-39386-000	N/A	N/A
	1	Single Point Circuit Breaker	N/A	N/A	025-34419-000	N/A	N/A	025-34419-000
	1	Single Point NF Disconnect Switch	N/A	024-31888-000	N/A	N/A	024-31870-000	N/A
2B	1	Lugs	N/A	025-34480-000	025-34418-000	N/A	025-34480-000	025-34418-000
2C	1	Ground Lug	025-34089-000	025-34089-000	025-34089-000	025-34089-000	025-34089-000	025-34089-000
2D	3	Safety Cover	025-39393-000	N/A	N/A	025-39393-000	N/A	N/A
3A	1	Control Board	031-02050-001	031-02050-001	031-02050-001	031-02050-001	031-02050-001	031-02050-001
3B	1	Eprom	031-02049-001	031-02049-001	031-02049-001	031-02049-001	031-02049-001	031-02049-001
4A	4	Compressor Contactor	024-35454-000	024-35454-000	024-35454-000	024-35467-000	024-35467-000	024-35467-000
4B	4	Surge Suppressor	031-00808-000	031-00808-000	031-00808-000	031-00808-000	031-00808-000	031-00808-000
4D	4	Auxiliary Contact	024-35493-000	024-35493-000	024-35493-000	024-35493-000	N/A	N/A
5	2	Control Relay	024-35526-000	024-35526-000	024-35526-000	024-35526-000	024-35526-000	024-35526-000
5A	2	Surge Suppressor	031-00808-000	031-00808-000	031-00808-000	031-00808-000	031-00808-000	031-00808-000
6B	1	Display	031-02100-000	031-02100-000	031-02100-000	031-02100-000	031-02100-000	031-02100-000
6D	1	Switch	024-25517-000	024-25517-000	024-25517-000	024-25517-000	024-25517-000	024-25517-000
6F	1	Ribbon Cable	031-01109-211	031-01109-211	031-01109-211	031-01109-211	031-01109-211	031-01109-211
7C	4	Fan Contactor	024-35441-000	024-35441-000	024-35441-000	024-35444-000	024-35444-000	024-35441-000
7D	4	Surge Suppressor	031-00808-000	031-00808-000	031-00808-000	031-00808-000	031-00808-000	031-00808-000
7E	2	Fuse Block	025-37863-000	025-37863-000	025-37863-000	025-37863-000	025-37863-000	025-37863-000
7F	6	Fuse	025-34142-000	025-34142-000	025-34142-000	025-34142-000	025-34142-000	025-34142-000
10	1	Ground Bar	025-35685-000	025-35685-000	025-35685-000	025-35685-000	025-35685-000	025-35685-000
11	1	Fuse Block	025-37862-000	025-37862-000	025-37862-000	025-37862-000	025-37862-000	025-37862-000
11A	1	Fuse	025-34435-000	025-34435-000	025-34435-000	025-34435-000	025-34435-000	025-34435-000

^S = Recommended Spare Part

SX*	SINGLE POINT TERMINAL BLOCK
SD*	SINGLE POINT NON-FUSED DISCONNECT SWITCH
BX*	SINGLE POINT CIRCUIT BREAKER

***Service Note:**

Locate the PANEL NUMBER sticker on the upper right hand corner of the power panel, then refer to the appropriate parts list for that number. Or, identify PIN number positions 16 and 17 on unit identification plate (See example on Page 4) then compare to table at right for power configuration options.

CONTROL PANEL AND POWER PANEL COMPONENTS (CONT'D)

TABLE 8 – CONTROL AND POWER PANEL COMPONENTS (SEE FIGS. 6 AND 6A, PAGES 21 AND 22)

Item	Qty	Description	YCAL0065-17 & YCAL0065-28			YCAL0065-40		
			371-04537-103* SX	371-04537-203* SD	371-04537-303* BX	371-04537-102* SX	371-04537-202* SD	371-04537-302* BX
2	1	Control Transformer	025-30889-000	025-30889-000	025-30889-000	025-30889-000	025-30889-000	025-30889-000
2A	1	Single Point Terminal Block	025-39386-000	N/A	N/A	025-39386-000	N/A	N/A
	1	Single Point Circuit Breaker	N/A	N/A	025-34419-000	N/A	N/A	025-34419-000
	1	Single Point NF Disconnect Switch	N/A	024-31870-000	N/A	N/A	024-31888-000	N/A
2B	1	Lugs	N/A	025-34480-000	025-34418-000	N/A	025-34480-000	025-34418-000
2C	1	Ground Lug	025-34089-000	025-34089-000	025-34089-000	025-34089-000	025-34089-000	025-34089-000
2D	3	Safety Cover	025-39393-000	N/A	N/A	025-39393-000	N/A	N/A
3A	1	Control Board	031-02050-001	031-02050-001	031-02050-001	031-02050-001	031-02050-001	031-02050-001
3B	1	Eprom	031-02049-001	031-02049-001	031-02049-001	031-02049-001	031-02049-001	031-02049-001
4A	4	Compressor Contactor	024-35467-000	024-35467-000	024-35467-000	024-35462-000	024-35462-000	024-35462-000
4B	4	Surge Suppressor	031-00808-000	031-00808-000	031-00808-000	031-00808-000	031-00808-000	031-00808-000
4D	4	Auxiliary Contact	024-35493-000	N/A	N/A	N/A	N/A	N/A
5	2	Control Relay	024-35526-000	024-35526-000	024-35526-000	024-35526-000	024-35526-000	024-35526-000
5A	2	Surge Suppressor	031-00808-000	031-00808-000	031-00808-000	031-00808-000	031-00808-000	031-00808-000
6B	1	Display	031-02100-000	031-02100-000	031-02100-000	031-02100-000	031-02100-000	031-02100-000
6D	1	Switch	024-25517-000	024-25517-000	024-25517-000	024-25517-000	024-25517-000	024-25517-000
6F	1	Ribbon Cable	031-01109-211	031-01109-211	031-01109-211	031-01109-211	031-01109-211	031-01109-211
7C	4	Fan Contactor	024-35444-000	024-35444-000	024-35441-000	024-35441-000	024-35441-000	024-35441-000
7D	4	Surge Suppressor	031-00808-000	031-00808-000	031-00808-000	031-00808-000	031-00808-000	031-00808-000
7E	2	Fuse Block	025-37863-000	025-37863-000	025-37863-000	025-37863-000	025-37863-000	025-37863-000
7F	6	Fuse	025-34142-000	025-34142-000	025-34142-000	025-34142-000	025-34142-000	025-34142-000
10	1	Ground Bar	025-35685-000	025-35685-000	025-35685-000	025-35685-000	025-35685-000	025-35685-000
11	1	Fuse Block	025-37862-000	025-37862-000	025-37862-000	025-37862-000	025-37862-000	025-37862-000
11A	1	Fuse	025-34435-000	025-34435-000	025-34435-000	025-34435-000	025-34435-000	025-34435-000

^S = Recommended Spare Part

SX*	SINGLE POINT TERMINAL BLOCK
SD*	SINGLE POINT NON-FUSED DISCONNECT SWITCH
BX*	SINGLE POINT CIRCUIT BREAKER

***Service Note:**

Locate the PANEL NUMBER sticker on the upper right hand corner of the power panel, then refer to the appropriate parts list for that number. Or, identify PIN number positions 16 and 17 on unit identification plate (See example on Page 4) then compare to table at right for power configuration options.

CONTROL PANEL AND POWER PANEL COMPONENTS (CONT'D)

TABLE 8 – CONTROL AND POWER PANEL COMPONENTS (SEE FIGS. 6 AND 6A, PAGES 21 AND 22)

Item	Qty	Description	YCAL0065-46, YCAL0065-50 & YCAL0065-58		
			371-04537-103* SX	371-04537-203* SD	371-04537-303* BX
2	1	Control Transformer	025-30889-000	025-30889-000	025-30889-000
2A	1	Single Point Terminal Block	025-39386-000	N/A	N/A
	1	Single Point Circuit Breaker	N/A	N/A	025-34419-000
	1	Single Point NF Disconnect Switch	N/A	024-31870-000	N/A
2B	1	Lugs	N/A	025-34480-000	025-34418-000
2C	1	Ground Lug	025-34089-000	025-34089-000	025-34089-000
2D	3	Safety Cover	025-39393-000	N/A	N/A
3A	1	Control Board	031-02050-001	031-02050-001	031-02050-001
3B	1	Eprom	031-02049-001	031-02049-001	031-02049-001
4A	4	Compressor Contactor	024-35467-000	024-35467-000	024-35467-000
4B	4	Surge Suppressor	031-00808-000	031-00808-000	031-00808-000
4D	4	Auxiliary Contact	024-35493-000	N/A	N/A
5	2	Control Relay	024-35526-000	024-35526-000	024-35526-000
5A	2	Surge Suppressor	031-00808-000	031-00808-000	031-00808-000
6B	1	Display	031-02100-000	031-02100-000	031-02100-000
6D	1	Switch	024-25517-000	024-25517-000	024-25517-000
6F	1	Ribbon Cable	031-01109-211	031-01109-211	031-01109-211
7C	4	Fan Contactor	024-35444-000	024-35444-000	024-35441-000
7D	4	Surge Suppressor	031-00808-000	031-00808-000	031-00808-000
7E	2	Fuse Block	025-37863-000	025-37863-000	025-37863-000
7F	6	Fuse	025-34142-000	025-34142-000	025-34142-000
10	1	Ground Bar	025-35685-000	025-35685-000	025-35685-000
11	1	Fuse Block	025-37862-000	025-37862-000	025-37862-000
11A	1	Fuse	025-34435-000	025-34435-000	025-34435-000

^S = Recommended Spare Part

SX*	SINGLE POINT TERMINAL BLOCK
SD*	SINGLE POINT NON-FUSED DISCONNECT SWITCH
BX*	SINGLE POINT CIRCUIT BREAKER

***Service Note:**

Locate the PANEL NUMBER sticker on the upper right hand corner of the power panel, then refer to the appropriate parts list for that number. Or, identify PIN number positions 16 and 17 on unit identification plate (See example on Page 4) then compare to table at right for power configuration options.

CONTROL WIRING HARNESSES

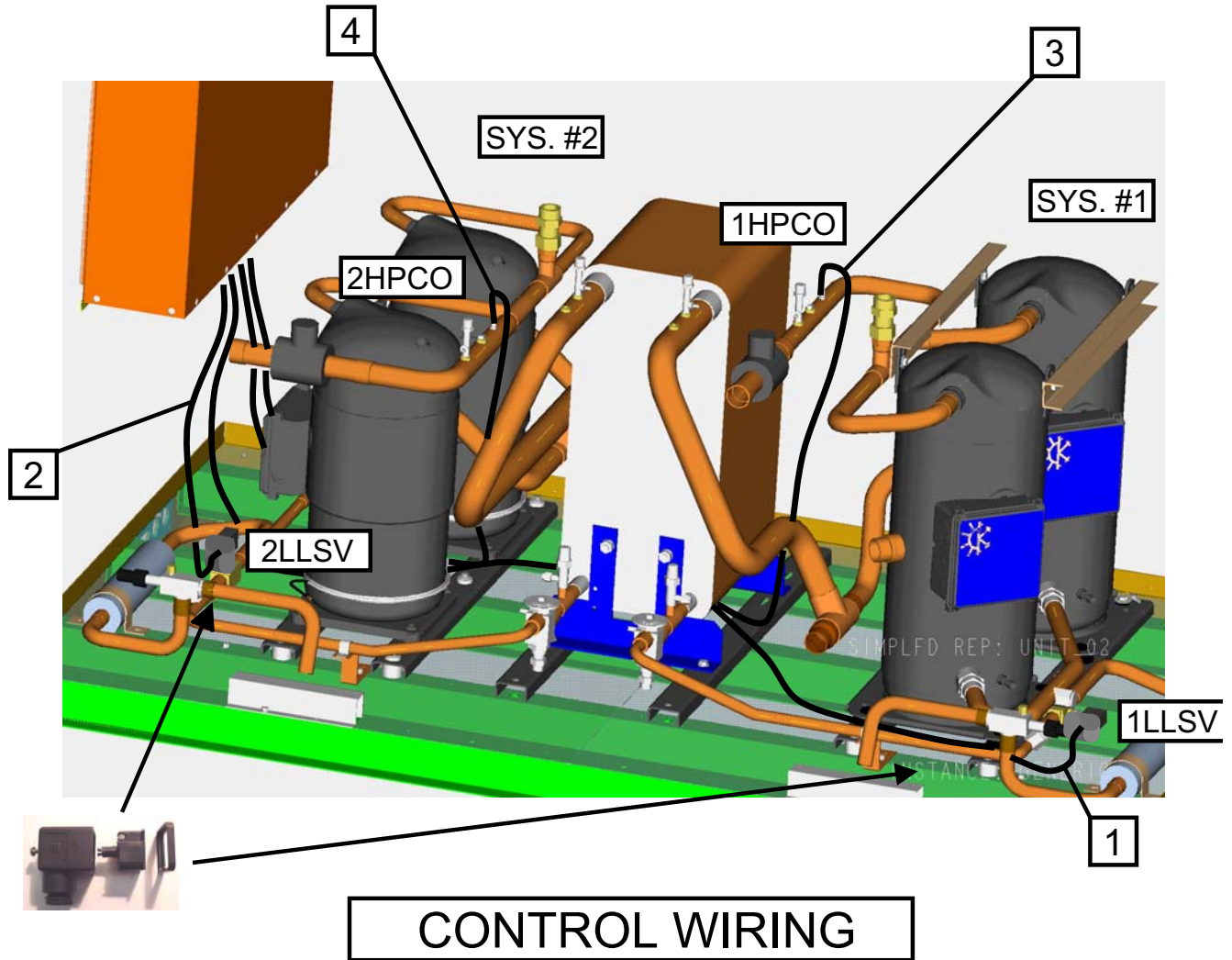

FIG. 7 – CONTROL WIRING HARNESSES (REF. TABLE 9)

TABLE 9 – CONTROL WIRING HARNESSES (SEE FIG. 7)

ITEM #	DESCRIPTION	SYSTEM	YCAL	PART NUMBER
1	HARNESS, LIQUID LINE SOLENOID VALVE	#1	0041-0051	575-57126-215
			0055-0065	575-57126-208
2	HARNESS, LIQUID LINE SOLENOID VALVE	#2	0041-0051	575-57126-216
			0055-0065	575-57126-209
3	HARNESS, HIGH PRESSURE CUT OUT	#1	0041-0051	575-57126-217
			0055-0065	575-57126-206
4	HARNESS, HIGH PRESSURE CUT OUT	#2	0041-0051	575-57126-218
			0055-0065	575-57126-207

Sensor Harnesses

SENSOR WIRING HARNESES

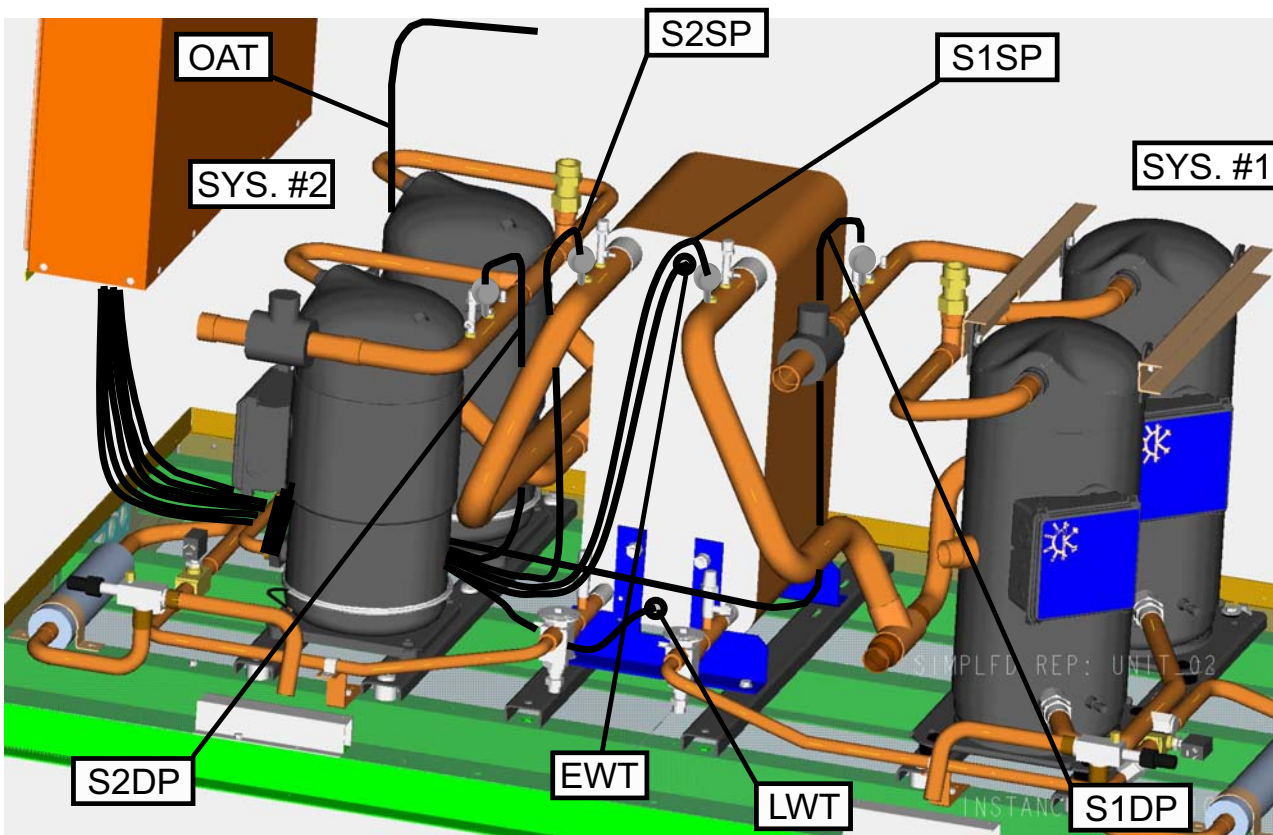

SENSOR WIRING

FIG. 8 – SENSOR WIRING HARNESES (REF. TABLE 10)

TABLE 10 – SENSOR HARNESS WIRING (SEE FIG. 8)

MICROBOARD WIRING							
Plug Detail	Plug and Pin P/N	Plug "P" No.	Plug Pin No.	Wire Color	Cable #	Function	Harness Assembly Part Number
	Plug = 025-28384-000 Pin = 025-28386-000	P4	5	Red	S1SP	System #1 Suction Pressure	575-57126-303
			10	White			
			1	Black	S1DP	System #1 Discharge Pressure	
			2	Drain			
	Plug = 025-28384-000 Pin = 025-28386-000	P7	7	Red	S2SP	System #2 Suction Pressure	575-57126-304
			12	White			
			8	Black	S2DP	System #2 Discharge Pressure	
			9	Drain			

Sensor Harnesses

TEMPERATURE SENSORS AND TRANSDUCERS

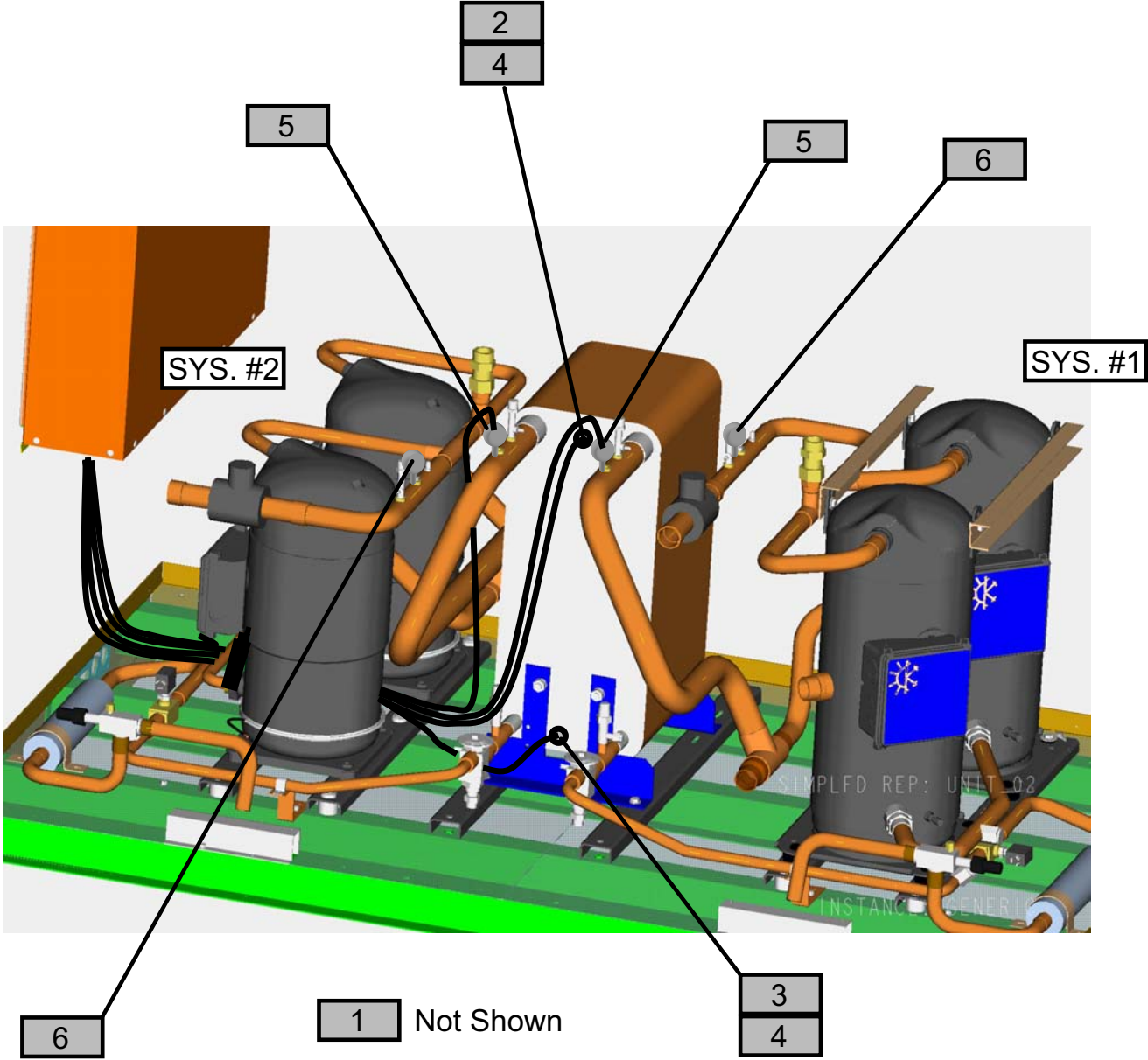

58363-005A

SENSORS AND TRANSDUCERS

FIG. 9 – TEMPERATURE SENSORS AND TRANSDUCERS (REF. TABLE 11, PAGE 36)

TEMPERATURE SENSORS AND TRANSDUCERS (CONT'D)

TABLE 11 – TEMPERATURE SENSORS AND TRANSDUCERS (SEE FIG. 9, PAGE 35)

Item Number	Qty	Description	Models	Part Number
1 ^S	1	Sensor, Outside Air Temperature (Cable Included)	0041-0051	025-40273-006
			0055-0065	025-40273-003
2 ^S	2	Sensor, Entering Water Temp. (Cable Included)	0041-0051	025-04273-005
			0055-0065	025-04273-002
3 ^S	2	Sensor, Leaving Water Temp. (Cable Included)	0041-0051	025-04273-004
			0055-0065	025-04273-001
4	-	Compound, Heat Conductive	All	013-00898-000
5 ^S	2	Transducer, Suction Pressure (0-200psi)	All	025-29583-000
6 ^S	2	Transducer, Discharge Pressure (0-400psi)	All	025-29139-001

S Recommended Spare Part

TRANSDUCER AND THERMISTOR WIRE HARNESS CONNECTORS - FIELD REPLACEMENT PART NUMBERS

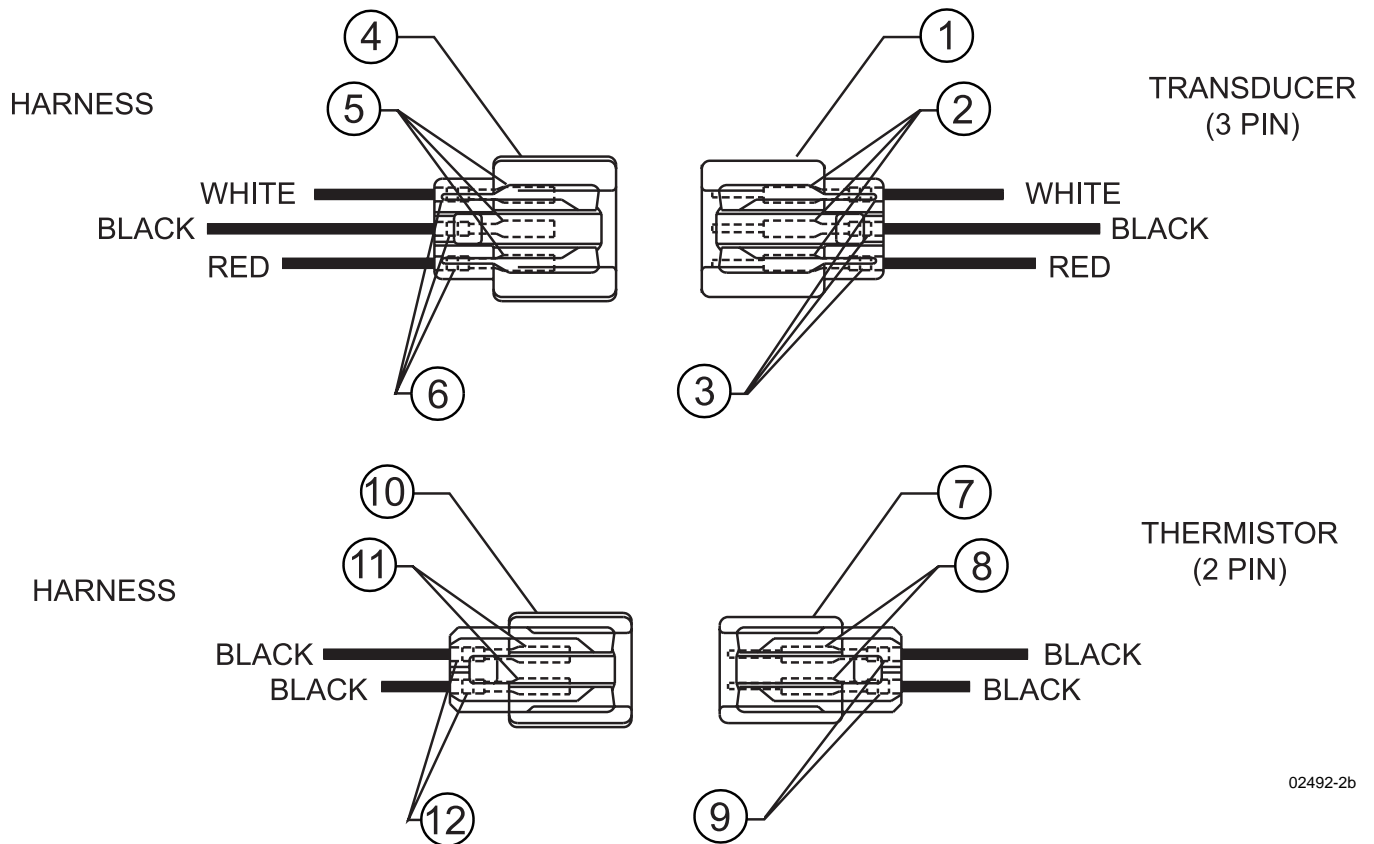

02492-2b

FIG. 10 – TRANSDUCER AND THERMISTOR WIRE HARNESS CONNECTORS - FIELD REPLACEMENT PART NUMBERS (REF. TABLE 12)

TABLE 12 – TRANSDUCER AND THERMISTOR WIRE HARNESS CONNECTORS - FIELD REPLACEMENT PART NUMBERS (SEE FIG. 10)

Item No.	Location	Description	Pins	Part Number
1	Transducer	Plug Connector	3 Pin End	025-28953-000
2		Contact Pins		025-28949-000
3		Rubber Collar		025-28950-000
4	Wire Harness	Plug Connector	3 Pin End	025-28954-000
5		Contact Pins		025-28952-000
6		Rubber Collar		025-28950-000
7	Transducer	Plug Connector	2 Pin End	025-28948-000
8		Contact Pins		025-28949-000
9		Rubber Collar		025-28950-000
10	Wire Harness	Plug Connector	2 Pin End	025-28951-000
11		Contact Pins		025-28952-000
12		Rubber Collar		025-28950-000

UNIT ENCLOSURE COMPONENTS

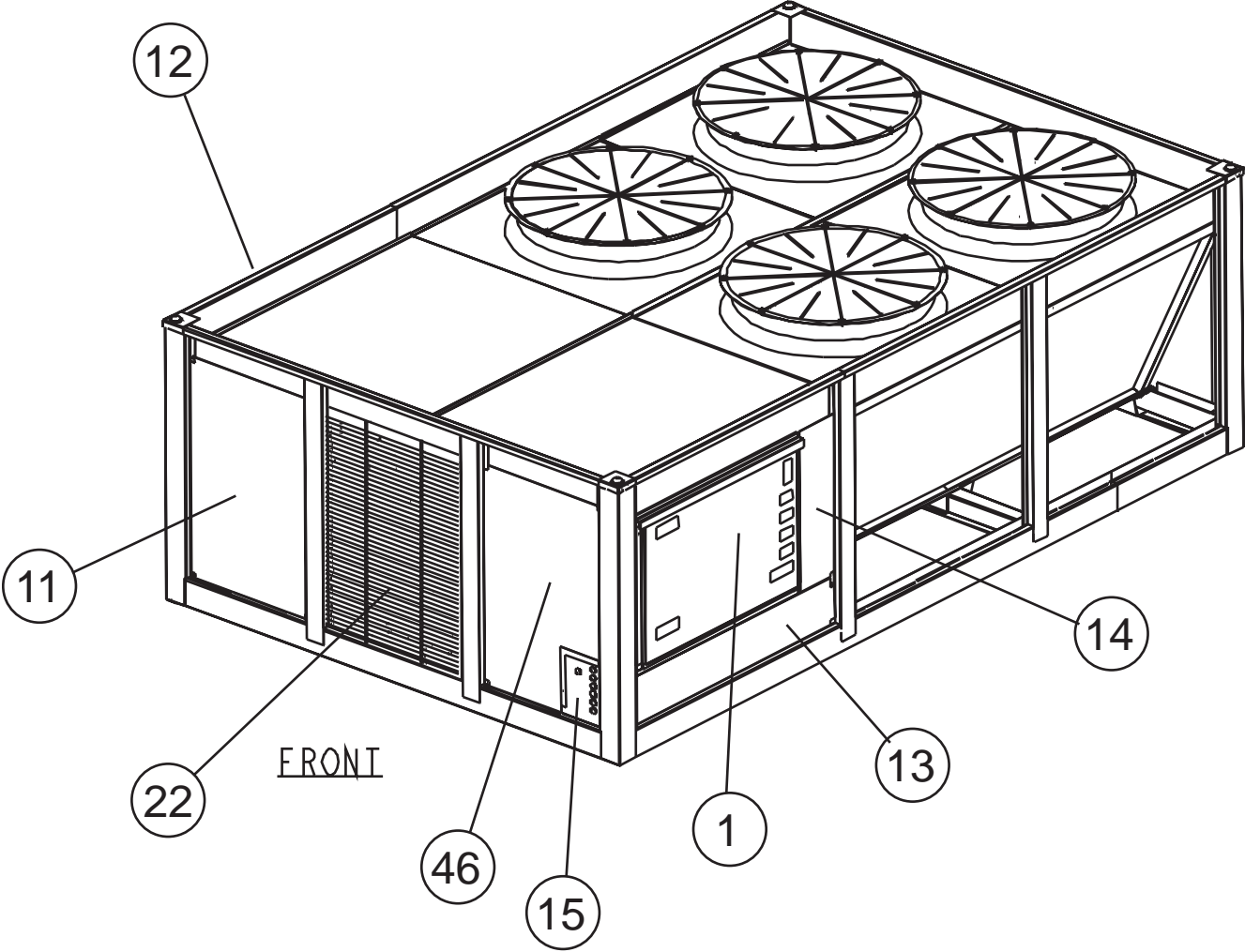

FIG. 11 – UNIT ENCLOSURE COMPONENTS (REF. TABLE 13, PAGE 39)

UNIT ENCLOSURE COMPONENTS (CONT'D)

TABLE 13 – UNIT ENCLOSURE COMPONENTS (SEE FIG. 11, PAGE 38)

Item Number	Qty	Description	Part Number	
			YCAL0041, 0045 AND YCAL0051	YCAL0055, 0061 AND YCAL0065
1	1	Panel, Front Enclosure	075-55957-005	075-55957-005
11	1	Panel	075-58273-007	075-58273-001
12	1	Panel	075-58273-008	075-58273-002
13	1	Panel	075-58273-009	075-58273-003
14	1	Panel	075-58273-004	075-58273-004
15	1	Panel	075-58273-005	075-58273-005
22	1	Grille, Coil Guard	026-41826-004	026-41826-002
46	1	Panel	075-58273-010	075-58273-006

VIBRATION ISOLATORS

TABLE 14 – VIBRATION ISOLATORS PART NUMBERS

ONE INCH DEFLECTION SPRING ISOLATOR CROSS REFERENCE				
FOR UNITS WITH ALL POINT LOADS LESS THAN 1404 LBS. (637 KG.)				
WEIGHT RANGE (lbs.)	WEIGHT RANGE (kg.)	VENDOR PART NUMBER	COLOR	YORK PART NUMBER
239 to 384 lbs.	108 to 174 kg.	CIP-B-450	RED	029-24583-002
384 to 639 lbs.	174 to 290 kg.	CIP-B-750	WHITE	029-24583-003
639 to 851 lbs.	290 to 386 kg.	CIP-B-1000	BLUE	029-24583-004
851 to 1064 lbs.	386 to 483 kg.	CIP-B-1250	GRAY	029-24583-005
1064 to 1404 lbs.	483 to 637 kg.	CIP-B-1650	BLACK	029-24583-006
FOR UNITS WITH ANY POINT LOAD ABOVE 1404 LBS. (637 KG.)				
WEIGHT RANGE (lbs.)	WEIGHT RANGE (kg.)	VENDOR PART NUMBER	COLOR	YORK PART NUMBER
Up to 851 lbs.	Up to 386 kg.	CIP-C-1000	BLACK	029-24583-007
851 to 1149 lbs.	386 to 521 kg.	CIP-C-1350	YELLOW	029-24583-008
1149 to 1489 lbs.	521 to 675 kg.	CIP-C-1750	BLACK	029-24583-009
1489 to 1786 lbs.	675 to 910 kg.	CIP-C-2100	YELLOW W/ RED	029-24583-010
1786 to 2028 lbs.	910 to 920 kg.	CIP-C-2385	YELLOW W/ GREEN	029-24583-011
2028 to 2254 lbs.	920 to 1022 kg.	CIP-C-2650	RED W/ RED	029-24583-012
2254 to 2936 lbs.	1022 to 1332 kg.	CIP-C-2935	RED W/ GREEN	029-24583-013

NEOPRENE ISOLATOR CROSS REFERENCE				
WEIGHT RANGE (lbs.)	WEIGHT RANGE (kg.)	VENDOR PART NUMBER	COLOR	YORK PART NUMBER
Up to 751 lbs.	Up to 341 kg.	ND-C	YELLOW	029-24584-001
751 to 1651 lbs.	341 to 749 kg.	ND-D	YELLOW	029-24584-002
1651 to 3226 lbs.	749 to 1463 kg.	ND-DS	YELLOW	029-24584-004

TWO INCH DEFLECTION, SEISMIC SPRING ISOLATOR CROSS REFERENCE				
WEIGHT RANGE (lbs.)	WEIGHT RANGE (kg.)	VENDOR PART NUMBER	COLOR	YORK PART NUMBER
Up to 358 lbs.	Up to 162 kg.	SLRS-2-C2-420	RED	029-24585-006
358 to 443 lbs.	162 to 201 kg.	SLRS-2-C2-520	WHITE	029-24585-007
443 to 582 lbs.	201 to 264 kg.	SLRS-2-C2-660	BLACK	029-24585-008
582 to 783 lbs.	264 to 335 kg.	SLRS-2-C2-920	BLUE	029-24585-009
783 to 1038 lbs.	335 to 471 kg.	SLRS-2-C2-1220	GREEN	029-24585-010
1038 to 1497 lbs.	471 to 679 kg.	SLRS-2-C2-1760	GRAY	029-24585-011
1497 to 2058 lbs.	679 to 933 kg.	SLRS-2-C2-2420	SILVER	029-24585-012
2058 to 2619 lbs.	933 to 1188 kg.	SLRS-2-C2-3080	GRAY W/ RED	029-24585-013
2619 to 3180 lbs.	1188 to 1442 kg.	SLRS-2-C2-3740	SILVER W/ RED	029-24585-014

CHILLER OPTIONS

TABLE 15 – FIELD INSTALLED OPTIONS KIT NUMBERS

MODEL NUMBER YCAL	HOT GAS BY-PASS SOLENOID VALVE W/ HARNESS	BAS/EMS TEMPERATURE RESET / OFFSET	MICRO GATEWAY	CHICAGO RELIEF VALVE	DIFFERENTIAL PRESSURE SWITCH	STANDARD 150# VICTAULIC FLANGE	OPTIONAL 300# VICTAULIC FLANGE
MODEL #	375-	375-30914	371-04455	022-08863	025-30919	023-22554	023-22553
0041	59425-200	-000	-010	-000	-000	-000	-000
0045							
0051	58485-200						
0055							
0061	58283-200						
0065							

* Note: Hot Gas By-Pass Solenoid Valve Only: 025-34133-000

MODEL NUMBER YCAL	STANDARD 150# FLOW SWITCH	OPTIONAL 300# FLOW SWITCH	LOW AMBIENT KIT	MOTOR CURRENT MODULE KIT	OPTIVIEW REMOTE CONTROL PANEL	RELIEF SAFETY DEVICE KIT	SOUND BLANKET KIT
MODEL #	024-26116	024-12144	375-59528	371-04101	371-02750	375-45657	310-06507
0041	-000	-000	-17 &-28 Voltage Codes -101 -40 Voltage Codes -103 -46 &-50 Voltage Codes -102 -58 Voltage Codes -104	-000	-101	-001	-710
0045							-710
0051							-711
0055							-712
0061							-713
0065							-714

TABLE 15A – CONTROL TRANSFORMER KIT

MODEL NUMBERS	VOLTAGE	DESCRIPTION	PART NUMBER
YCAL0041-YCAL0065	-17	KIT, CONTROL TRANSFORMER	375-59641-101
	-28		375-59641-102
	-40		375-59641-103
	-46		375-59641-104
	-50		375-59641-105
	-58		375-59641-106

ENCLOSURE KIT OPTIONS

TABLE 16 – ENCLOSURE KIT OPTIONS

MODEL NUMBER	WIRE ENCLOSURE (FACTORY INSTALLED)	LOUVERED ENCLOSURE (FIELD INSTALLED)
YCAL-0041	375-59527-000	475-59445-000
YCAL-0045		
YCAL-0051		
YCAL-0055	375-59526-000	475-59444-000
YCAL-0061		
YCAL-0065	375-59525-000	475-59443-000

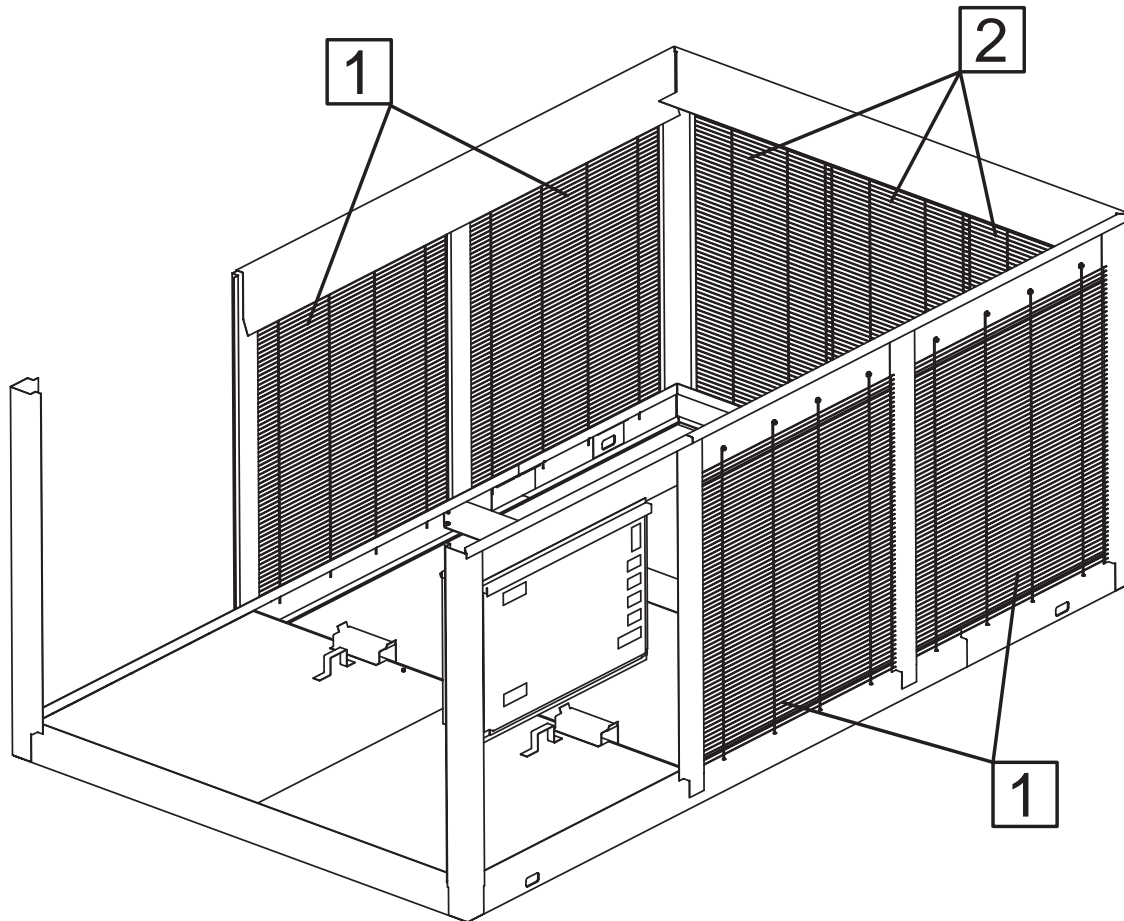

59525-000

FIG. 12 – WIRE ENCLOSURE PARTS (REF. TABLE 17)

TABLE 17 – WIRE ENCLOSURE PARTS - (SEE FIG. 12)

WIRE ENCLOSURE KIT COMPONENTS							
ITEM #	DESCRIPTION	YCAL0041, 0045 and YCAL0051		YCAL0055 and YCAL0061		YCAL0065	
		375-59527-000	QTY	375-59526-000	QTY	375-59525-000	QTY
1	WIRE PANEL, SIDES	026-41826-005	4	026-41826-003	4	026-41826-001	4
2	WIRE PANEL, REAR	026-41826-004	3	026-41826-002	3	026-41826-002	3

ENCLOSURE KIT OPTIONS (CONT'D)

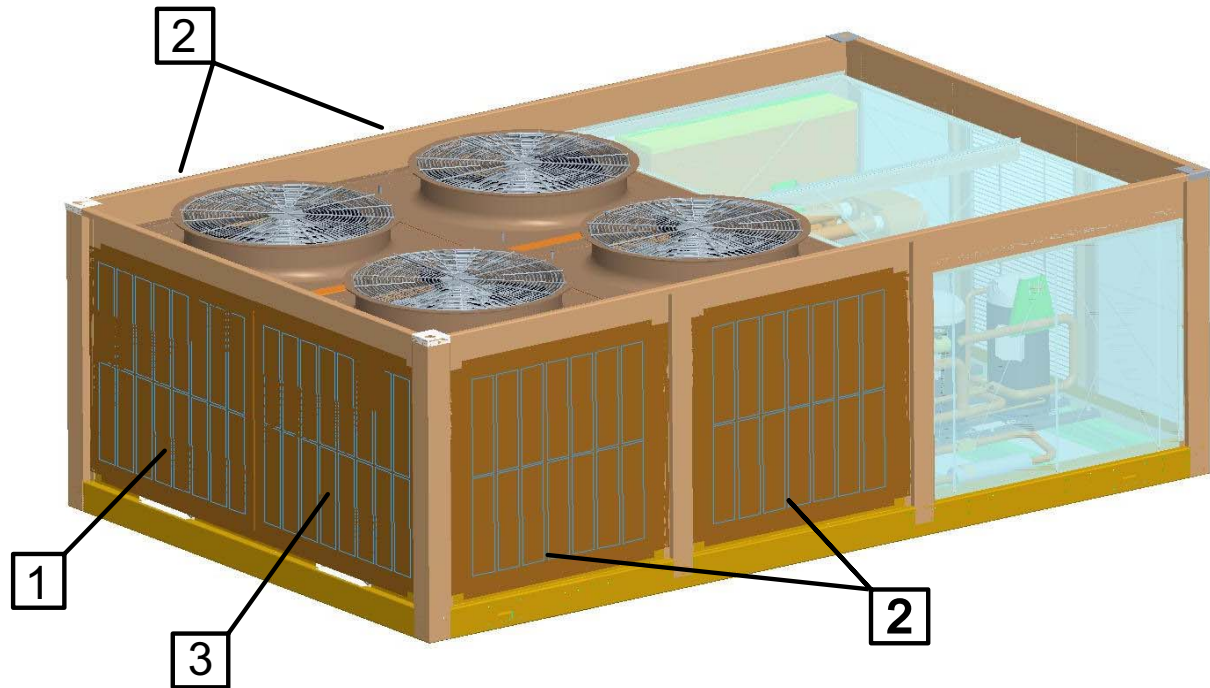

Chiller Options

60803-000

FIG. 13 – LOUVERED ENCLOSURE PARTS (REF. TABLE 18)

TABLE 18 – LOUVERED ENCLOSURE PARTS - (SEE FIG. 13)

LOUVERED ENCLOSURE KIT COMPONENTS							
ITEM #	DESCRIPTION	YCAL0041, 0045 and YCAL0051		YCAL0055 and YCAL0061		YCAL0065	
		475-59445-000	QTY	475-59444-000	QTY	475-59443-000	QTY
1	LOUVERED PANEL	075-60803-001	1	075-60803-005	1	075-60803-005	1
2	LOUVERED PANEL	075-60803-002	4	075-60803-004	4	075-60803-007	4
3	LOUVERED PANEL	075-60803-003	1	075-60803-006	1	075-60803-006	1

OPTIVIEW REMOTE CONTROL CENTER

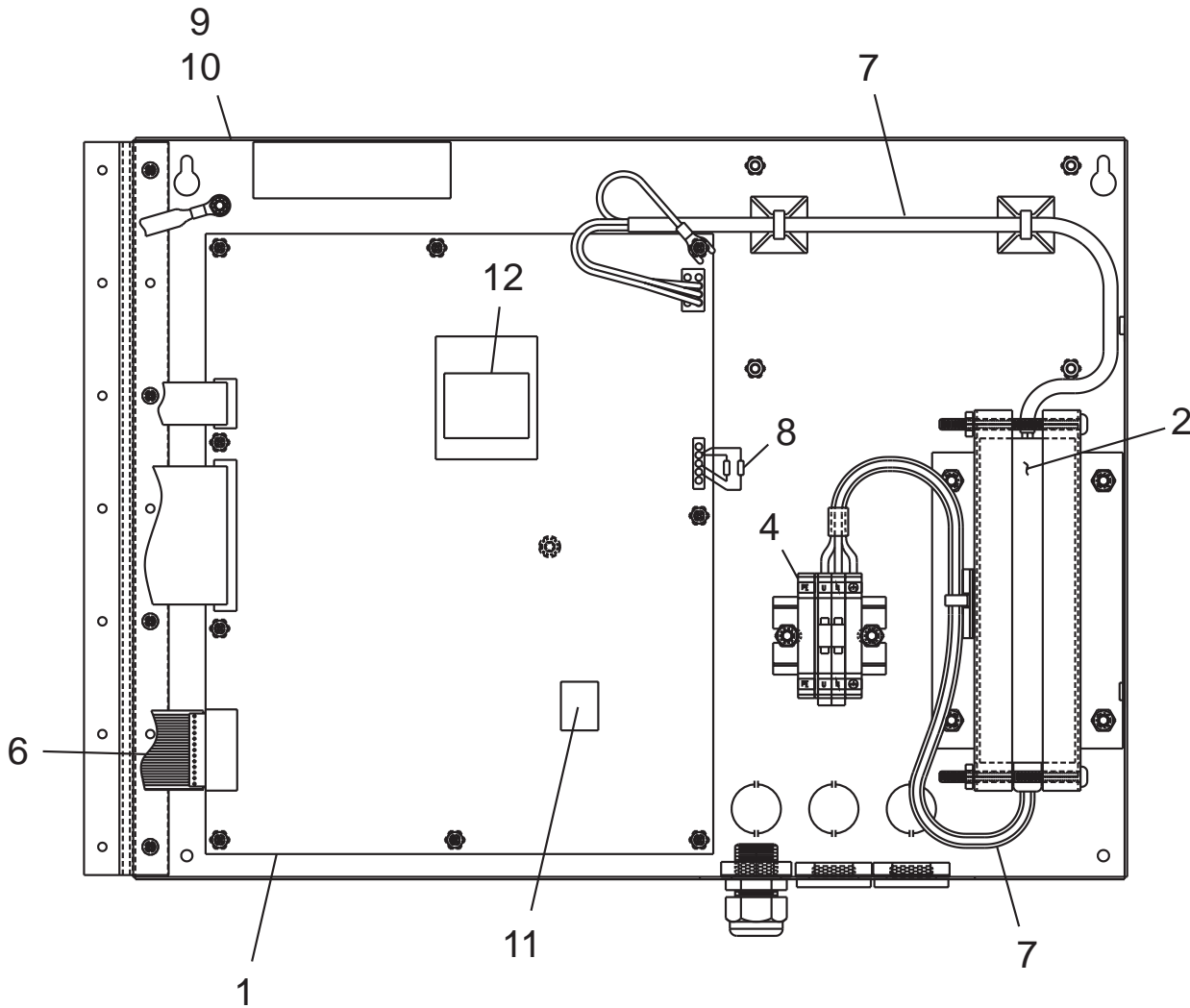

FIG. 14 – OPTIVIEW REMOTE CONTROL CENTER PARTS

02750-3A

TABLE 19 – OPTIVIEW REMOTE CONTROL CENTER PARTS

371-02750-101			
ITEM NUMBER	QTY	DESCRIPTION	PART NUMBER
1	1	MICROPROCESSOR BOARD	031-01730-002
2	1	POWER SUPPLY ASSEMBLY	371-02750-411
3	1	KEYPAD (NOT SHOWN)	024-30974-001
4	1	TERMINAL BLOCK	025-35120-000
5	1	DISPLAY (NOT SHOWN)	331-02053-000
6	1	RIBBON CABLE	031-02056-000
7	1	WIRE CABLE	571-02750-421
8	8	LAN TRANSIENT PROTECTION MODULE	031-01586-000
9	1	COVER, REMOTE CONTROL	371-02750-311
10	1	BASE, REMOTE CONTROL	071-02485-320
11	1	EPROM	031-01796-002
12	1	FLASH MEMORY CARD	031-02057-001

REMOTE CURRENT/TEMPERATURE RESET PARTS BREAKDOWN

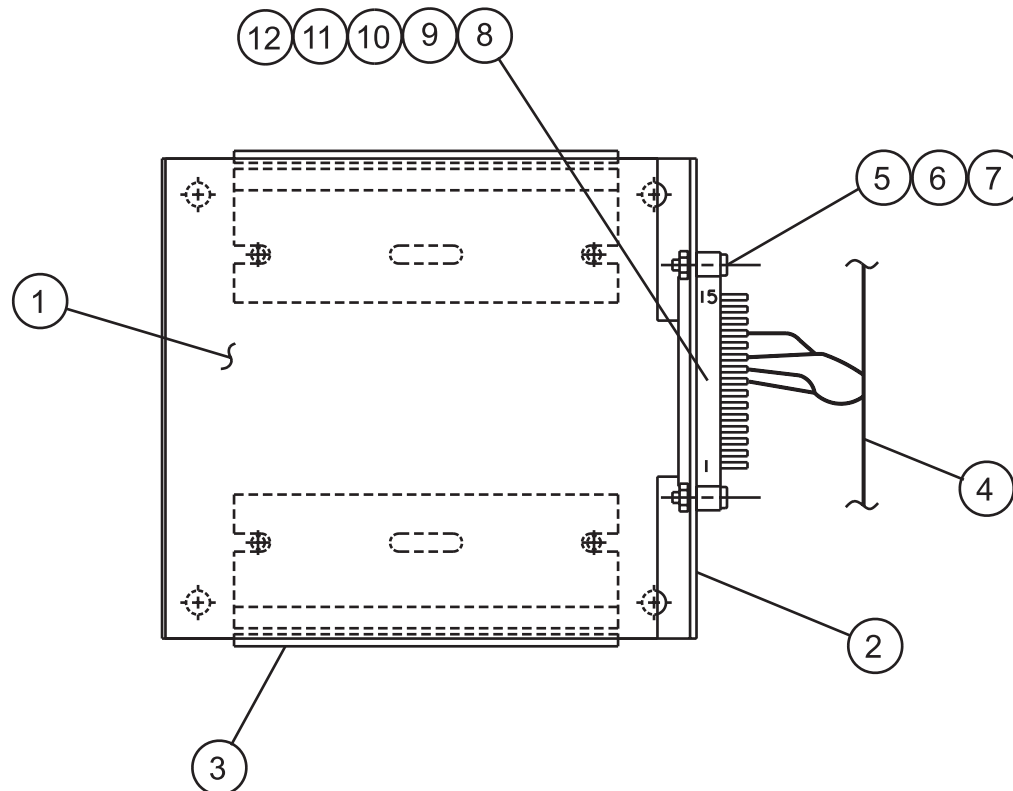

LD05256

Chiller Options

FIG. 15 – REMOTE TEMPERATURE RESET KIT COMPONENTS

TABLE 20 – REMOTE TEMPERATURE RESET KIT COMPONENTS

375-90914-000			
ITEM NUMBER	QTY	DESCRIPTION	PART NUMBER
1	1	CONTROL, REMOTE CURRENT/TEMPERATURE	031-00814-000
2	1	BRACKET, REMOTE CURRENT/ TEMPERATURE RESET	371-01232-361
3	1	TRACK, SNAP	071-01232-363
4	1	WIRING, REMOTE CURRENT/ TEMPERATURE RESET	571-02492-231*
5	2	SCREW, MACHINE PAN HEAD #4	021-17594-000
6	2	NUT, HEX #4 - 40 UNC-2B	021-10056-000
7	2	LOCKWASHER, HELICAL SPRING #4 REGULAR	021-17576-000

* refer to Table 20A

TABLE 20A – REMOTE RESET WIRING

ITEM NUMBER	QTY	DESCRIPTION	PART NUMBER
8	2	CONT SOC AWG WIRE SIZE 20	025-19674-000
9	2	TERMINAL PUSH ON STRAIGHT	025-06642-000
10	4	TUBING HEAT SHRINKABLE 1/8" I.D.	025-29632-000
11	1	HGS CONNECTOR ELECTRICAL PLUG	025-32564-000*
12	1	CONNECTOR EDGE, 15 POSITION, 0.125	025-17594-000

RECOMMENDED SPARE PARTS

York Model YCAL Style D Air Cooled Liquid Chillers
Suggested Spare Parts List for Critical Duty Applications

TABLE 21 – RECOMMENDED SPARE PARTS - YCAL STYLE 'D' CHILLERS

PAGE REF. & ITEM NUMBER	DESCRIPTION	MODEL NUMBER YCAL	PART NUMBER
Page 10, Item 1	Fan Motor	All	See Table 4
Page 10, Item 2	Fan Blade	All	
Page 15 & 16, Item 1	Thermal Expansion Valve	All	See Table 5
Page 15 & 16, Item 4	Valve, Liquid Line		
Page 18, Item OIL	Oil, Compressor	All	See Table 6B
Page 38, Item 1	Sensor, Outside Air	0041-0051	025-40273-006
		0055-0065	025-40273-003
Page 38, Item 2	Sensor, Entering Water Temperature	0041-0051	025-40273-005
		0055-0065	025-40273-002
Page 38, Item 3	Sensor, Leaving Water Temperature	0041-0051	025-40273-004
		0055-0065	025-40273-001
Page 38, Item 5	Transducer, Suction Pressure	All	025-29583-000
Page 38, Item 6	Transducer, Discharge Pressure	All	025-29139-001

Spare Parts

All parts should be purchased from your local
YORK Sales and Service Center.

NOTES

