



BY JOHNSON CONTROLS

Service Information

File In/With: N/A

SI0259

Supersedes SI0259 (1013)

REV

615

Equipment Affected:

25, 26, 38 and 56 inch Multi-stage Compressors

Kinetrol Pneumatic Actuator with Integrated AP Pneumatic Positioner

GENERAL

The Kinetrol pneumatic actuator is an upgrade from the standard actuator and can be retro fitted on existing installations. The Kinetrol actuator is installed on all new multi-stage compressor products. Retro fit kits and mounting kits can be ordered directly from the Baltimore Parts Distribution Center. If additional assistance is required contact the Product Technical Support Hotline at 1-800-524-1330, and follow the prompts for industrial systems support.

This publication is tailored for identifying parts required to retrofit compressors originally supplied with Conoflow actuators to current production Kinetrol PRV actuators. If a specific compressor was supplied from the factory with a Kinetrol actuator installed always use part numbers listed on the compressor assembly drawings when ordering replacements.

PARTS

TABLE 1 - PRV ACTUATOR MOUNTING KITS

COMPRESSOR SIZE	EXTENDED PRV COVER SIDE MOUNT KITS	
	With Handwheel	Without Handwheel
25 and 26 inch	381-19650-000	381-19648-000
38 inch	381-19553-000	381-19586-000
55 inch	381-19657-000	381-19658-000
COMPRESSOR SIZE	STANDARD PRV COVER SIDE MOUNT KITS	
	With Handwheel	Without Handwheel
25 and 26 inch	381-19649-000	381-19647-000
38 inch	381-19579-000	381-19633-000
55 inch	381-19660-000	381-19659-000

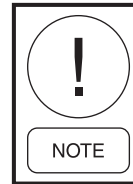

The PRV actuator must be ordered separately (see table 3 for more information).

See the last page of this document for a visual reference of the mounting kit with actuator installed.

Work on this equipment should only be done by properly trained personnel who are qualified to work on this type of equipment. Failure to comply with this requirement could expose the worker, the equipment and the building and its inhabitants to the risk of injury or property damage.

The instructions on this service bulletin are written assuming the individual who will perform this work is a fully trained HVAC & R journeyman or equivalent, certified in refrigerant handling and recovery techniques, and knowledgeable with regard to electrical lock out/tag out procedures. The individual performing this work should be aware of and comply with all Johnson Controls, national, state and local safety and environmental regulations while carrying out this work. Before attempting to work on any equipment, the individual should be thoroughly familiar with the equipment by reading and understanding the associated service literature applicable to the equipment. If you do not have this literature, you may obtain it by contacting a Johnson Controls Service Office.

Should there be any question concerning any aspect of the tasks outlined in this bulletin, please consult a Johnson Controls Service Office prior to attempting the work. Please be aware that this information may be time sensitive and that Johnson Controls reserves the right to revise this information at any time. Be certain you are working with the latest information.

Product Technical Support

TABLE 2 - ACCESSORY KITS FOR ACTUATORS

FEATURE	YORK PART NUMBER	DESCRIPTION
I to P Transducer	024-37332-000	Explosion Proof
4-20mA Position Feedback Module	024-37333-000	Explosion Proof
End Switches	024-37334-000	Explosion Proof

TABLE 3 - ACTUATORS

COMPRESSORS	YORK PART NUMBER	INTEGRATED AP PNEUMATIC POSITIONER ¹	DIRECTION OF ROTATION ON INCREASING SIGNAL	INTEGRAL I/P	INTEGRAL 4-20 MA POSITION FEEDBACK	ELECTRICAL CLASSIFICATION
25 and 26 inch	024-39351-000	Yes	CCW	No	No	IP54
	024-39352-000	Yes	CCW	Yes	Yes	NEMA 4, 4X
	024-39353-000	Yes	CCW	Yes	Yes	Class 1, Div 1, Groups B-G
	024-39354-000	Yes	CCW	Yes	Yes	ATEX, IP55
38 inch Kinetrol Model 12	024-38990-000	Yes	CCW	No	No	IP54
	024-38991-000	Yes	CCW	Yes	Yes	NEMA 4, 4X
	024-38992-000	Yes	CCW	Yes	Yes	Class 1, Div 1, Groups B-G
	024-39019-000	Yes	CCW	Yes	Yes	ATEX, IP55
55 inch	024-38197-000	Yes	CW	No	No	IP54
	024-38195-000	Yes	CW	Yes	Yes	NEMA 4, 4X
	024-38196-000	Yes	CW	Yes	Yes	Class 1, Div 1, Groups B-G
	024-39020-000	Yes	CW	Yes	Yes	ATEX, IP55

Note: 1. Integrated AP Pneumatic Positioner works off a 3-15 psig signal.

SPECIFICATIONS

TABLE 4 - ACTUATOR AND INTEGRATED PNEUMATIC POSITIONER SPECIFICATIONS

ITEM	SPECIFICATION
Air Supply	Instrument quality (dry, clean and oil free) 50 to 100 psi (3.5 to 7.0 bar). Preferred 100 psi (7.0 bar)
Control Response	0-60° linear output standard
Flowrate	MP: 10.0 scfm (283 nl/min) @ 5.5 bar
Operating Temperature Range	-4° to 176°F (-20° to 80°C) standard -4° to 212°F (-20° to 100°C) High Temperature
Weight	28.2 to 44.5 lbs (12.8 to 20.2 kg)
Hazardous area use	North American: FMC/U Class I, Division 1, gas groups B,C,D. Class II, Division 1, dust groups E,F,G. ATEX: Gas: Ex Group II, Category 2 G Ex d IIB T6 Dust: Ex Group II, Category 2 D Ex tD A21 T6
Output Torque	25" and 26" Compressor – 3625 lb-in (410 N•m) at 100 psi (7 bar) 38" Compressor – 5000 lb-in (575 N•m) at 100 psi (7 bar) 55" Compressor – 12000 lb-in (1375 N•m) at 100 psi (7 bar)
Vibration Tolerance	4G, 100Hz

VERIFY PRV 0% POSITION



Calibrate the position of the Pre-rotation Vanes (PRVs) before the removal of the standard actuator. The position of the PRVs should be verified at 0% before the standard actuator is removed or damage to the unit may occur. The Kinetrol Pneumatic Actuator and Positioner should be installed after the PRVs 0% position has been established.

SETTINGS AND ADJUSTMENTS

The AP Pneumatic Positioner is factory set. However, if these settings need to be changed, contact Product Technical Support Hotline at 1-800-524-1330, and follow the prompts for industrial systems support.

Verification should be made that PRV linkage does not bind during full travel from open to close or comes in contact with mounting brackets. Should this occur adjust linkage as required to correct. If over rotation of actuator is cause of problem the full open or full close stop position can be limited by using the stop screws found on sides of actuator.

MAINTENANCE AND TROUBLESHOOTING

The AP Pneumatic Positioner is designed for low maintenance when supplied with clean, dry, oil free air. The following Troubleshooting table should help in the unlikely event of a problem with the performance. If additional assistance is required contact the Product Technical Support Hotline at 1-800-524-1330, and follow the prompts for industrial systems support.

TABLE 5 - TROUBLESHOOTING

PROBLEM	REMEDY
Failure to move when signal air and main air is applied	<ul style="list-style-type: none"> • Check main air pressure is sufficient to produce enough torque from actuator. • Has the coupling been positioned at the correct angular position on the actuator? • The external port connections been fitted the correct way? • Is the air quality poor, causing the spool to jam? This can be checked by manually moving the spool carefully by hand. • Is the actuator or attached components jammed? Contact the Product Technical Support Hotline at 1-800-524-1330, and then use phone prompts 6-1-1-4-3 for instructions.
Actuator moves too slowly upscale or down scale	<ul style="list-style-type: none"> • Verify that the main air pressure is not too low for the load being moved or that the actuator too small? • Verify that the air is not contaminated and causing the spool movement to become sluggish?

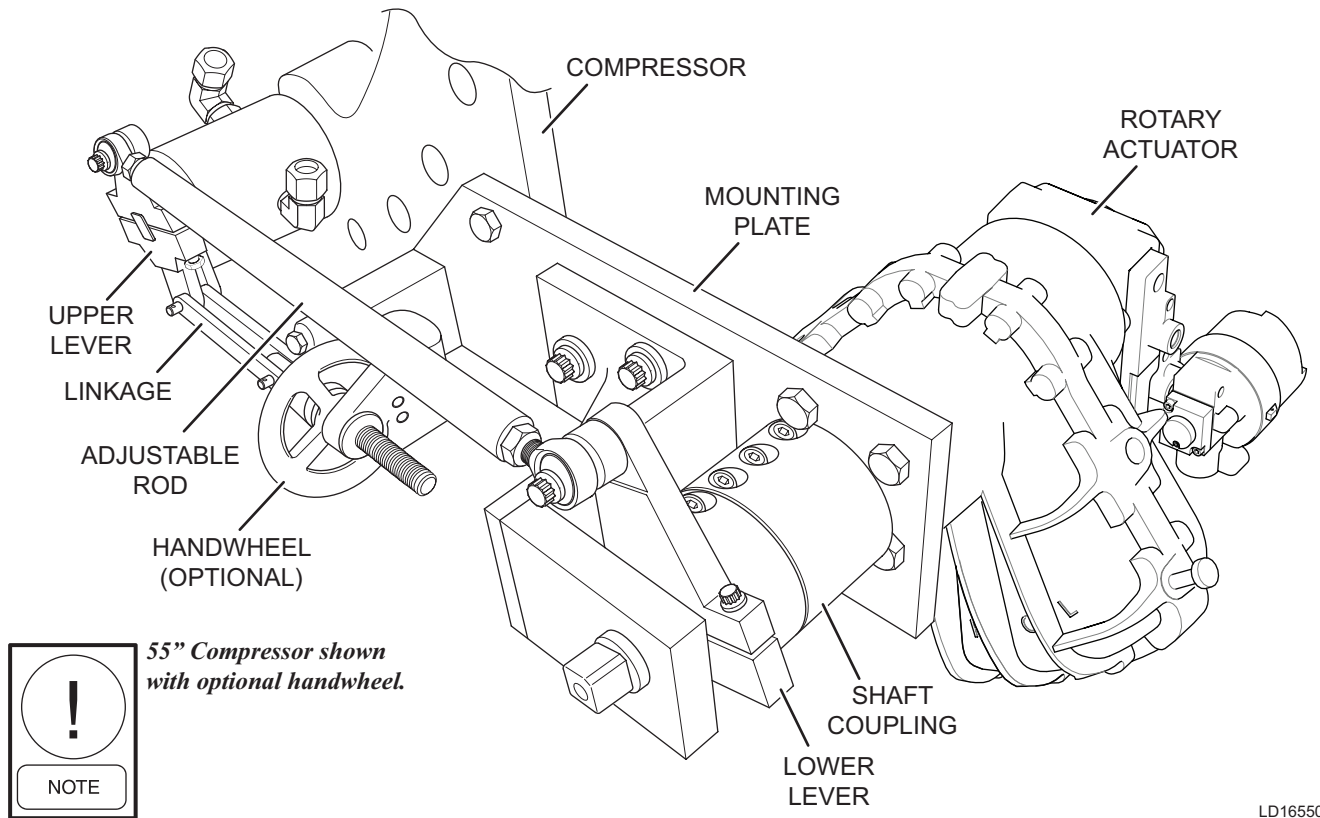

FIGURE 1 - KINETROL PNEUMATIC ACTUATOR WITH PRV ACTUATOR MOUNTING KIT

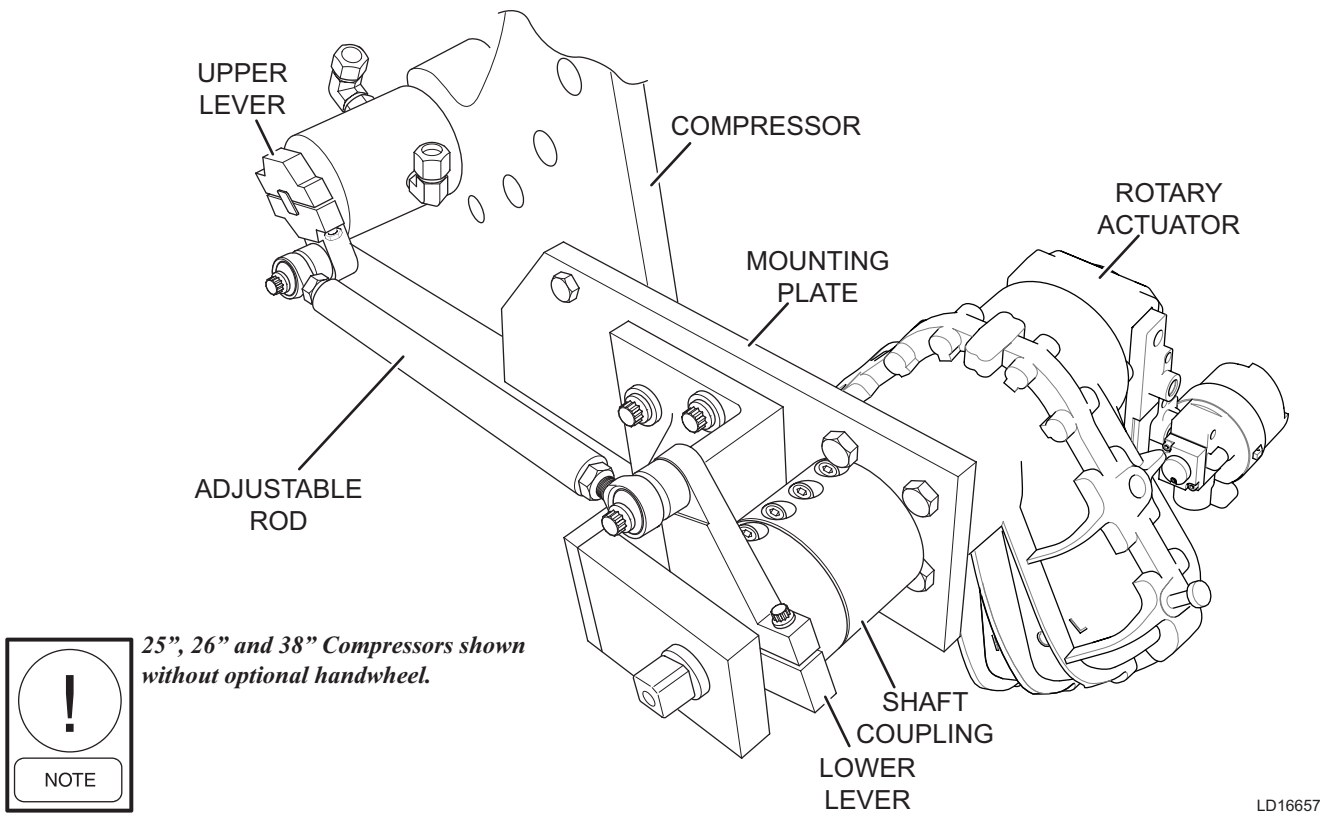

FIGURE 2 - KINETROL PNEUMATIC ACTUATOR WITH PRV ACTUATOR MOUNTING KIT

THIS PAGE INTENTIONALLY LEFT BLANK.