



LIQUID COOLED VARIABLE SPEED DRIVE FOR YCAV (LATITUDE) CHILLERS

SERVICE INSTRUCTIONS

Supersedes: Nothing

Form 201.21-M1 (305)

TROUBLESHOOTING GUIDE FOR LIQUID COOLED VARIABLE SPEED DRIVE



50056

60 / 50 Hz (P/N 371-04178-XXX)

IMPORTANT!

READ BEFORE PROCEEDING!

GENERAL SAFETY GUIDELINES

This equipment is a relatively complicated apparatus. During installation, operation, maintenance or service, individuals may be exposed to certain components or conditions including, but not limited to: refrigerants, oils, materials under pressure, rotating components, and both high and low voltage. Each of these items has the potential, if misused or handled improperly, to cause bodily injury or death. It is the obligation and responsibility of operating/service personnel to identify and recognize these inherent hazards, protect themselves, and proceed safely in completing their tasks. Failure to comply with any of these requirements could result in serious damage to the equipment and the property in

which it is situated, as well as severe personal injury or death to themselves and people at the site.

This document is intended for use by owner-authorized operating/service personnel. It is expected that this individual possesses independent training that will enable them to perform their assigned tasks properly and safely. It is essential that, prior to performing any task on this equipment, this individual shall have read and understood this document and any referenced materials. This individual shall also be familiar with and comply with all applicable governmental standards and regulations pertaining to the task in question.

SAFETY SYMBOLS

The following symbols are used in this document to alert the reader to areas of potential hazard:



DANGER indicates an imminently hazardous situation which, if not avoided, will result in death or serious injury.



CAUTION identifies a hazard which could lead to damage to the machine, damage to other equipment and/or environmental pollution. Usually an instruction will be given, together with a brief explanation.



WARNING indicates a potentially hazardous situation which, if not avoided, could result in death or serious injury.

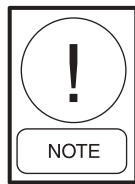

NOTE is used to highlight additional information which may be helpful to you.



External wiring, unless specified as an optional connection in the manufacturer's product line, is NOT to be connected inside the micro panel cabinet. Devices such as relays, switches, transducers and controls may NOT be installed inside the micro panel. NO external wiring is allowed to be run through the micro panel. All wiring must be in accordance with YORK's published specifications and must be performed ONLY by qualified YORK personnel. YORK will not be responsible for damages/problems resulting from improper connections to the controls or application of improper control signals. Failure to follow this will void the manufacturer's warranty and cause serious damage to property or injury to persons.

TABLE OF CONTENTS

SCREW COMPRESSOR DRIVE GENERAL INFORMATION.....	4
Reference Instructions	4
LATITUDE COMPRESSOR DRIVE COMPONENT OVERVIEW	5
Latitude Compressor Drive	5
LATITUDE COMPRESSOR DRIVE CONTROL SYSTEM OVERVIEW	7
The Chiller Control Center	7
Latitude Compressor Drive Logic Board	7
Chiller Control Center VSD Related Keypad Functions	11
UNIT SHUTDOWNS	11
General Information	11
DC Bus Voltage Imbalance	11
High DC Bus Voltage	12
High VSD Internal Ambient Temp	12
Low DC Bus Voltage	12
Motor Current Overload	12
Precharge DC Bus Voltage Imbalance	13
Precharge - Low DC Bus Voltage	13
Single Phase Input Voltage	13
VSD Communications Failure	13
VSD CT Plug Fault	14
VSD Logic Board Failure	14
VSD Logic Board Power Supply	14
SYSTEM SHUTDOWNS	15
General Information.....	15
Gate Driver	15
High Motor Current	16
High VSD Baseplate Temperature	17
Table 1 - LCD - Thermistor Characteristics	18
Motor Current Overload	18
VSD Run Relay	18
WARNING MESSAGES.....	18
General Information	18
Invalid Number of Compressor Selected	18
START-UP PREPARATIONS.....	19
Circuit Breaker Setup	19
Verify Overload Settings	19
VSD FREQUENTLY ASKED QUESTIONS	19
TROUBLESHOOTING AND COMPONENT REPLACEMENT PROCEDURES.....	20
General Information	20
Verify Failure of the LCD IGBT Module	20
Verify Failure of the LCD SCR/Diode Module	25
Replacement of the LCD IGBT Module	26
Replacement of the LCD SCR/Diode Module	28
SOFTWARE REFERENCE LIST 50 HZ AND 60 HZ	29

OPTISPEED COMPRESSOR DRIVE GENERAL INFORMATION

This instruction is to be used in conjunction with the Operation and Service Instructions for YORK Model YCAV (Latitude) chillers.

Reference Instructions

Installation, Operation and Service (Unit)

Form 201.21-NM1

Wiring Diagram

Form 201.21-PW1

Replacement Parts List

Form 201.21-RP1

YCAV CHILLER COMPRESSOR DRIVE MODEL NUMBER DEFINITIONS

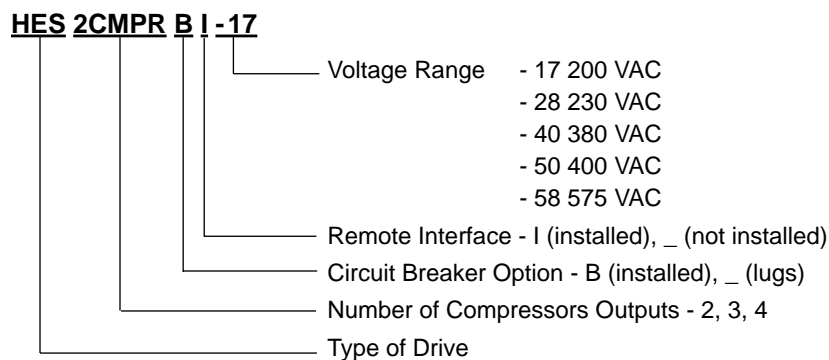

MODEL NUMBER	PART NUMBER	
	60 HZ	50 HZ
HES2COMPR__-17	371-04178-101	—
HES2COMPR__-28	371-04178-102	—
HES2COMPR__-40	371-04178-103	—
HES2COMPR__-46	371-04178-105	—
HES2COMPR__-58	371-04178-106	—
HES2COMPR__-50	—	371-04178-104

The YCAV (Latitude) compressor drive is also available with other options. Refer to the sales information for additional part numbers for those models.

LATITUDE COMPRESSOR DRIVE COMPONENT OVERVIEW

YCAV (Latitude) Compressor Drive

The new YORK Latitude Compressor Drive (LCD) is a liquid cooled, transistorized, PWM inverter in a highly integrated package. Refer to Figs. 1 and 2.

The LCD is not an option to the chiller as with other YORK compressor drives. The LCD has a maximum output of 200 Hz at 460 VAC. The motor used on the compressor is a 138 VAC at 60 Hz motor.

The power section of the drive is composed of four major blocks:

- An AC to DC rectifier section with an integrated pre-charge circuit,
- A DC link filter section,
- A three phase DC to AC inverter section, and
- An output suppression network.

An electronic circuit breaker with ground fault sensing is an option on this product. An input lug connection is standard. The lugs connect the AC line to the input fuses then to an AC line choke, and then to the DC converter. The following description of operation is specific for the 2 and 3 compressor Latitude compressor drive. Refer to Fig. 2.

The AC to DC semi-converter uses 3 Silicon Controlled Rectifiers (SCR's) and 3 diodes. One SCR and one diode are contained in each module. Three modules are required to convert the 3 phase input AC voltage into DC voltage (1SCR-3SCR) in a three-phase bridge configuration (Fig. 2). The modules are mounted on a liquid cooled heatsink. The use of the SCR's in the semi-converter configuration permits pre-charge of the DC link filter capacitors when the chiller enters start, and it also provides a fast disconnect from the AC line when the chiller has a unit fault condition.

When the chiller enters the unit fault condition, or is shut down the LCD is turned off, the SCR's in the semi-converter are no longer turned on, and remain in a turned off, or non-conducting mode. The DC link filter capacitors will start to discharge through the bleeder resistors. When the chiller enters the start cycle, the LCD is commanded to pre-charge, the SCR's are gradually turned on with a delay angle to slowly charge the DC link filter capacitors. This is called the pre-charge period, which last for 20-seconds. After the 20-second time period has expired, the SCR's are gated

fully on. The SCR Trigger board (031-02060) provides the turn "on", and turn "off" commands for the SCR's during precharge, and during normal running condition as commanded by the LCD Logic board (031-02477).



Although many of these parts are similar to the parts used in previous Variable Speed Drive (VSD) designs, these parts are only compatible with drives having the base part numbers included on the cover of this form. Failure to use the correct parts may cause major damage to these and other components in the drive. For example, the LCD logic board 031-02477-000 used in this drive is not compatible with 031-02077-000 logic board used in previous designs.

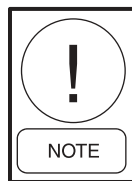

The figures for the 2 compressor drive are included in this form.

The DC Link filter section of the drive consists of one basic component: a series of electrolytic filter capacitors (C1-C6). These capacitors provide a large energy reservoir for use by the DC to AC inverter section of the LCD. The capacitors are contained in the LCD Power Unit. In order to achieve a suitable voltage capability between the DC Link voltage, and the rating of the filter capacitors, two capacitors are placed in series to form a "pair", and then paralleling a suitable number of "pairs" to form a capacitor "bank". In order to assure an equal sharing of the voltage between the series connected capacitors, and to provide a discharge path for the capacitor bank when the LCD is powered off, "bleeder" resistors (1RES and 2RES) are connected across the capacitor banks. The "bleeder" resistors are mounted on the side of the Power Unit.

The DC to AC inverter section of the LCD serves to convert the DC voltage back to AC voltage at the proper magnitude and frequency as commanded by the LCD Logic board. The inverter section is actually composed of one power unit. This power unit is composed of very fast switching transistors called an Insulated Gate Bipolar Transistor (IGBT) module (1MOD & 2MOD) mounted on the same liquid cooled heatsink as the

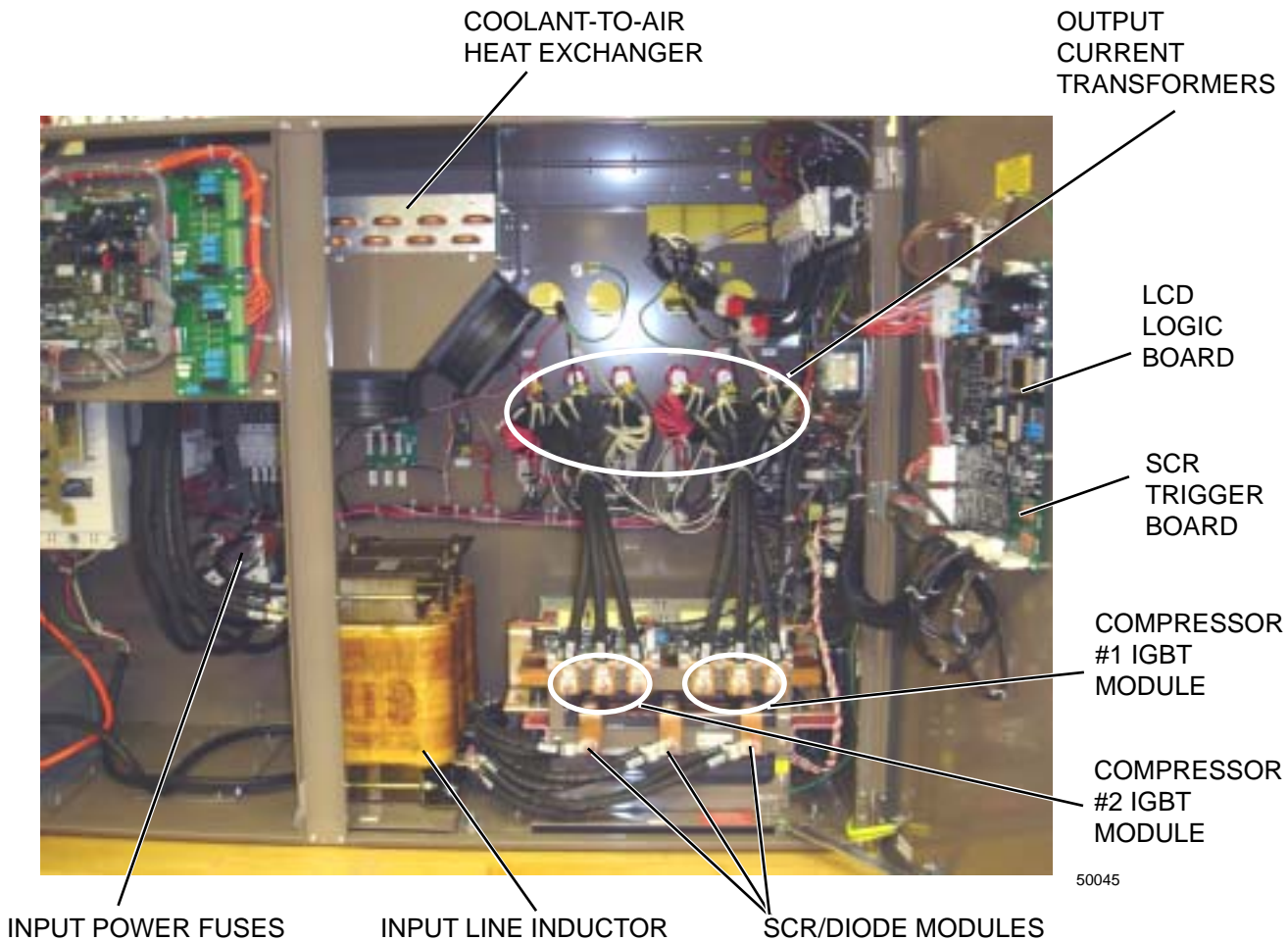

FIG. 1 – LCD CONTROL PANEL

semi-converter modules, the DC Link filter capacitors (C1-C6), a semi-converter, and an LCD Gate Driver board (031-02061). This board provides the turn on, and turn off commands to the IGBT's output transistors. The Latitude Compressor Drive Logic board determines when the turn on, and turn off commands should occur. The gate driver board is mounted directly on top of the IGBT module, and it is held in place with mounting screws and soldered to the IGBT module. Refer to Fig. 4. This improves reliability by eliminating the gate wires and their possible failure of older designs.

If the IGBT modules and the capacitor bank were connected together with wire, a large amount of inductance from the wire would cause a failure in the IGBT. To reduce the inductance YORK employs a "laminated bus" structure technology. The "laminated bus" structure connects the IGBT module to the capacitor bank through 2 copper plates that are insulated from each other. When an insulator separates 2 copper plates they form a capacitor, which will counter act the inductance. Refer to Fig.4. To further cancel the inductances in the laminated bus structure, a series of small film capacitors (C7-C12) are connected between the positive and negative plates at the IGBT modules.

The LCD output suppression network is composed of a series of capacitors (C13-C18) and resistors (3RES-14RES) connected in a three-phase delta configuration. The parameters of the suppression network components are chosen to work in unison with the inductance of the DC to AC inverter sections in order to simultaneously limit both the rate of change in voltage and the peak voltage applied to the motor windings. By limiting the peak voltage to the motor windings, as well as the rate-of-change in motor voltage, we can avoid problems commonly associated with PWM motor drives, such as stator-winding end-turn failures and electrical fluting of motor bearings.

Other sensors and boards are used to convey information back to the LCD Logic board, and provide safe operation of the Latitude Compressor Drive. The IGBT modules contain a thermistor temperature sensor (RT1 and RT2) that provides temperature information back to the LCD logic board via the gate driver boards. The Bus Voltage Isolator board (031-01624) utilizes three resistors on the board to provide a "safe" resistance between the DC link filter capacitors located in the LCD power unit and the LCD logic board. It provides the means to sense the positive, midpoint and negative voltage connection

points of the LCD's DC link. Six Current Transformers (4T-9T) monitor the output current from the LCD power unit and are used to protect the motor from overcurrent conditions.

LATITUDE COMPRESSOR DRIVE CONTROL SYSTEM OVERVIEW

The LCD is housed in the same cabinet as the rest of the chiller control system. The chiller control board dictates to the LCD what RPM to run the compressor based on the leaving chilled liquid temperature control, or any limiting controls. The only time the LCD will override the control system is when a shutdown condition for the LCD is occurring.

The LCD control system is composed of various components located within Chiller Control Center. Thus, integrating the Chiller Control Center with the LCD. The LCD system utilizes various microprocessors and Digital Signal Processors (DSPs), which are linked together through a serial communications link.

The Chiller Control Center

The Chiller Control Center contains 2 main boards. One, the chiller control board, which controls all aspects of the chiller as well as the output speed of the LCD. Two the LCD logic board, which determines precharge of the LCD, evaluates fault conditions for the LCD, and determines how and when to turn on or off the output of the LCD.

The chiller control board and the LCD logic board communicate via a serial cable. Under normal conditions the chiller control board is sending a RPM command to the LCD logic board. The LCD logic board will determine the correct output frequency and voltage to rotate the compressor motor. In a LCD generated fault condition, the LCD logic board will open it's fault relay, turn off the output of the drive, and then report the fault along with fault data to the chiller control board.

Latitude Compressor Drive Logic Board

The LCD logic board performs numerous functions, control of the LCD's cooling fans and pump, when to pre-charge the bus capacitors, and generates the PWM. Refer to Fig #3 for the location of the various connectors on the LCD logic board.

- The internal cooling fans and pump are commanded to turn on whenever the LCD is commanded to run via J10 pins 1 and 2. They will turn off when the

drive is commanded to stop. If the LCD shutdown is due to a high-temperature condition, then the internal cooling fans and pumps will continue to run until the value of the internal temperature has dropped below a specified value.

In an attempt to keep the internal temperature of the LCD cool enough to start, the LCD's internal cooling fans and pump will turn on without the chiller running if the internal temperature is within 10°F of the fault value. This fault value will be different depending on the number of compressors mounted on the chiller. The internal cooling fans and pump will turn off when the internal temperature of the drive is 15°F below the fault value

The LCD's cooling fans and pump will also run if the chiller is placed in service mode, and the status of the VSD cooling fan/pump is enabled. The removal of a thermistor connector is no longer required to turn on and off the fans and pump as with other drives used on YORK's large tonnage products.

- The LCD Logic board sends a command signal to the SCR gate driver board to precharge the bus capacitors. For pre-charge to become active J11 Pin 3 must be low, and J11 Pin 4 must be at 7.5 VDC
- The PWM generation is required so that the output of the LCD will provide to the motor the proper voltage for a given output frequency. The PWM generation is sent to the IGBT gate driver board via J6 for compressor #1, and J8 for compressor #2.

The LCD logic board also determines shutdown conditions by monitoring the three phases of motor current for each compressor, baseplate temperature for each IGBT module, internal ambient temperature, and the DC Link voltage.

- Current transformers mounted on the output motor wiring to the compressor monitor the output motor current and send this information to the J1 and J2 connectors.
- The baseplate temperature is monitored by a thermistor mounted inside each IGBT module. Any of the thermistors can cause an over temperature fault. The thermistor voltage is read at the J6 and J8 connector.
- The internal ambient temperature is monitored by a thermistor mounted on the LCD Logic board.
- The DC link isolator board monitors the DC link voltage and is connected to J3.

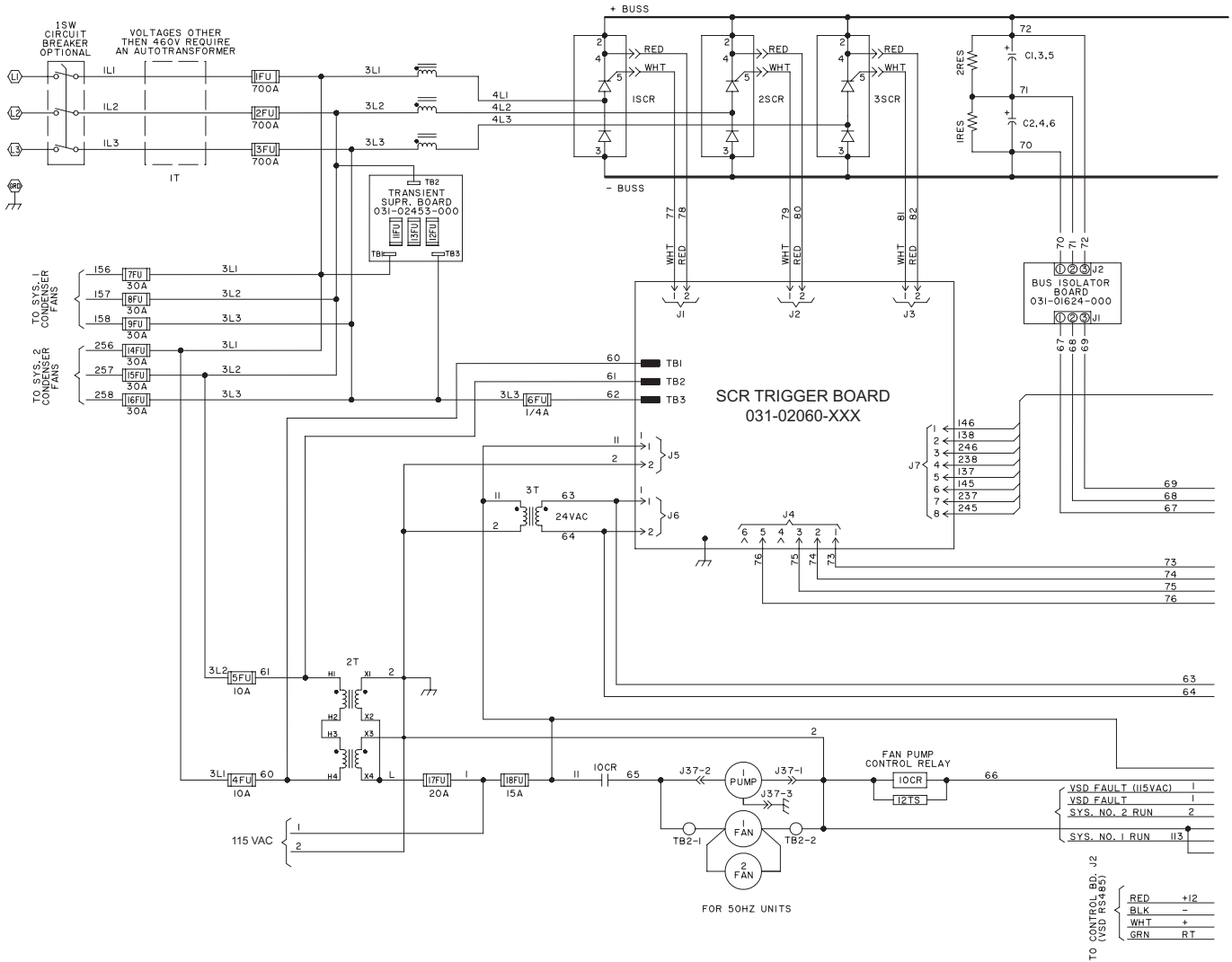

LD09468

FIG. 2 – LCD SCHEMATIC

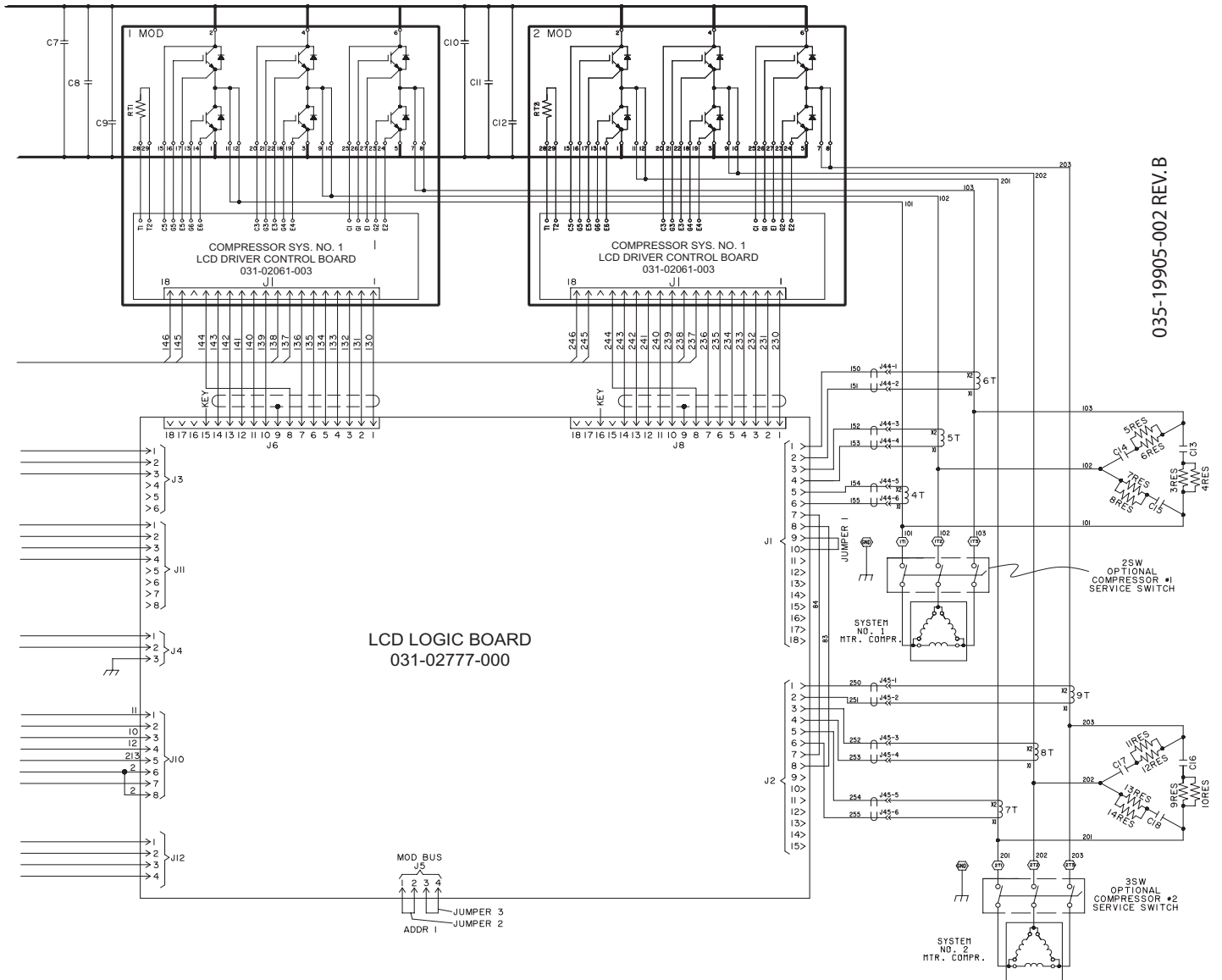

035-19905-002 REV. B

- | | | |
|-----------------------------|------------------------------------|---|
| ① SCR TRIGGER OUTPUT J11 | ⑧ OVERLOAD SET POT COMPR #1 | ⑮ OVERLOAD LED |
| ② COMMS TO MICROBOARD J12 | ⑨ BUS VOLTAGE FEEDBACK J3 | ⑯ COMPRESSOR ENABLE LED'S |
| ③ FAULT LED | ⑩ MTR CURRENT FEEDBACK COMPR #2 J2 | ⑰ GATE DRIVER TEST SWITCH SW1 |
| ④ INPUT POWER SUPPLY J4 | ⑪ MTR CURRENT FEEDBACK COMPR #1 J1 | ⑱ POWER LED |
| ⑤ MODBUS J5 | ⑫ IGBT GATE DRIVE COMPR #1 J6 | ⑲ RUN CMD, FAULT RELAY OUTPUT, FAN & PUMP CONTROL J10 |
| ⑥ COMPRESSOR RUN LED'S | ⑬ IGBT GATE DRIVE COMPR #2 J8 | ⑳ SEND & RECEIVE COMMS LED'S |
| ⑦ OVERLOAD SET POT COMPR #2 | ⑭ GATE DRIVER LED'S | |

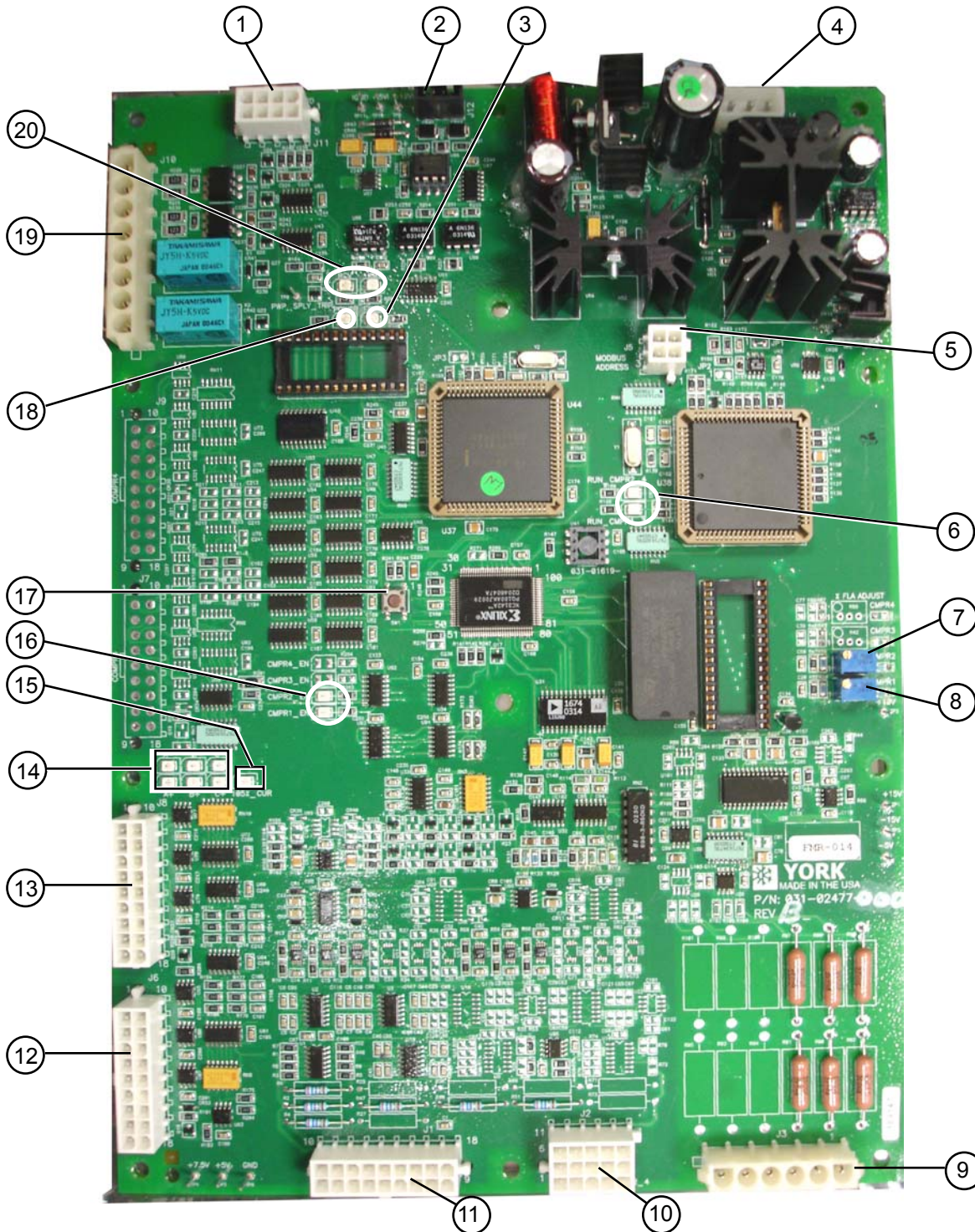

FIG. 3 – LATITUDE COMPRESSOR DRIVE LOGIC BOARD DETAILS

50046

The LCD logic board also contains many LEDs to indicate various conditions of the drive. Refer to Fig. 3 for the location of various LEDs.

- 105% LED will light whenever any phase of motor current is 5% greater than 100% current rating as set by the percent FLA adjustment pot.
- A-, A+, B-, B+, C-, C+ LEDs light whenever the IGBT gate driver is turned off, and will not light whenever the IGBT gate driver is turned on. At low motor output frequencies these LEDs will flash. They will remain on constantly when the drive is running at high output frequency.
- RCV, XMT LEDs will flash when the LCD logic board is communicating with the chiller control board. Each should flash about once a second.
- Power LED will light any time power is applied to the LCD logic board.
- Fault LED will light whenever the fault relay is open indicating a fault condition.
- Compressor Enable LED will light when the drive has received the hardware and software run signal from the chiller control logic board for that compressor. Four LEDs are located on the logic board, one for each compressor.
- Compressor Run LED will light when the drive has received the hardware run signal from the chiller control logic board. Two LED's are located on the logic board, one for each chiller system.

Chiller Control Center VSD Related Keypad Functions

Refer to form 201.21-NM1 for related keypad functions.

UNIT SHUTDOWNS

General Information

The Unit Shutdowns are organized in alphabetical order based on the Chiller Control Center messages.

Whenever a Unit Shutdown is generated by the LCD a series of events will occur.

- Any shutdown that occurs while the chiller is not running will cause a start inhibit. The chiller cannot be started until the shutdown has been cleared.
- If the chiller is running when the shutdown occurs the LCD logic board will turn off all of the IGBT gate drivers.

- The fault relay for the faulted system on the LCD logic board will de-energize causing a momentary open circuit between J10-3 and J10-4. Opening the circuit will indicate to the Chiller Control Center that the LCD has shutdown. The fault relay will remain de-energized until the Chiller Control board has acknowledged the cause of the shutdown. Once the Chiller Control board has acknowledged the shutdown the fault relay will close.
- The LCD logic board will send a shutdown code via the serial communications link to the Chiller Control board. The Chiller Control board will interpret the shutdown code, and display a shutdown message on the display of the Chiller Control Center.

After the reason for the shutdown has been corrected, the chiller may auto restart, but will lock out the operation of the chiller if the same shutdown were to occur 3 times within a 90-minute window unless otherwise noted in the shutdown information.

DC Bus Voltage Imbalance

The DC bus voltage is filtered by many large, electrolytic capacitors, which are rated for 450 VDC. These capacitors are wired in series to achieve a 900 VDC capability for the DC bus voltage. It is important that the voltage is shared equally from the junction of the center, or series capacitor connection, to the negative bus and to the positive bus.

This center point should be approximately $\frac{1}{2}$ of the total DC link voltage. If the voltage is greater than ± 100 VDC from the $\frac{1}{2}$ of the total DC link voltage, then this shutdown will occur. This shutdown will lockout the operation of the chiller on the first event.

Possible Problems:

- Bleeder resistors failure due to overheating. Ensure that the thermal pad is installed, and the bleeder resistor mounting nuts are tight. A new thermal pad should be installed when the resistors are replaced.
- Verify the wiring between the large capacitors, the bus isolator board, LCD logic board, and the bleeder resistors.
- Failure of the bus voltage isolation board. Use 2 DC volt meters to verify the voltage across the 2 halves of the DC bus. If the voltage is correct, then measure the DC bus voltage at the J3 connector of the LCD logic board.

- Shorted or open capacitor in one half of the cap bank.
- Verify that the 2 bleeder resistors are the same value. The value should be 2.4K ohms.

High DC Bus Voltage

While the chiller is running, the DC bus voltage is continuously monitored by the LCD logic board through the bus voltage isolation board. If the level of the bus voltage were to exceed 766 VDC (for 50 or 60 Hz), a shutdown is initiated. This shutdown will protect the capacitors from a voltage that exceeds their rating.

Possible Problems:

- Ensure that the voltage at the input power fuses is within 414-508 VAC phase to phase.
- Ensure that this shutdown is not a result of a storm.
- This shutdown may be the result of power grid switching.
- Meg the compressor motors. If a phase has gone to ground this shutdown may be displayed.

High VSD Internal Ambient Temp

The ambient temperature of the LCD is monitored by a temperature sensor mounted on the LCD logic board. The high ambient trip threshold is set for 158°F (70°C). If this shutdown occurs, the internal cooling fans, coolant pump, and condenser fans will remain turn on until the internal ambient temperature has fallen to 143°F (62°C). This shutdown is always an auto-restart when the internal temperature has dropped below the shutdown level.

Possible Problems:

- Improper coolant level for the LCD.
- Failure of a coolant hose or clamp.
- Ensure that the coolant hoses are not kinked.
- Verify that the coolant system is not leaking.
- Coolant temperature entering the LCD of greater than 140°F or 60°C.
- Dirty condenser is causing higher than normal coolant liquid temperatures. Regular maintenance of the condenser is required.
- Failure of a fuse for the coolant pump or internal fans.
- Internal fan failure at the cooling coil.
- Failure of the coolant pump.

- Failure of a condenser fan, condenser fan motor or a condenser fan fuse..

Low DC Bus Voltage

While the chiller is running, the DC bus voltage is continuously monitored by the LCD logic board through the bus voltage isolation board. If the line voltage were to quickly drop the current seen by the motor could exceed it's rating or the rating of the IGBT. The low bus voltage shutdown will prevent this from happening. The shutdown is generated when the bus voltage drops below 500 VDC (for 50 or 60 Hz).

Possible Problems:

- A common cause for this shutdown is a severe sag in the AC line voltage to the drive. Monitor the incoming three phase AC line voltage for severe sags, and also monitor the DC link voltage with a digital meter.
- There could be a wiring problem between the DC link, bus isolator board, or the LCD logic board. Refer to the wire diagram for the wire numbers. Measure the voltage at J3 pin #1 to pin #2 on the LCD logic board. Care should be taken when making this measurement. The value should be around 600 VDC when the drive is running.
- The resistors on the bus isolator board could be out of tolerance. With power removed from the chiller measure the resistors on the DC isolator board (031-01624-000). Measure from J1 to J2 pin 1 to 1, pin 2 to 2, and pin 3 to 3 with the J1 and J2 connectors removed. The resistance value should be 150K ohms +/- 1.5K ohms for each reading.

Motor Current Overload

This shutdown is generated when the LCD logic board has detected that the highest of the three output phase currents for any compressor has exceeded 105% of the programmed 100% full load amps (FLA) value for more than 30 seconds. The 100% FLA setpoint is determined by adjustment of the FLA trimpots on the LCD logic board. Each compressor motor has it's own trimpot. This shutdown will lockout the operation of the chiller on the first event.

Possible Problems:

- FLA value not properly set for the application of each compressor.
- High condenser pressure.
- Restriction in the refrigerant circuit.

- The economizer valve not working properly or stuck open.
- Feed and drain valves not working properly causing the compressor to overload.

Precharge DC Bus Voltage Imbalance

The definition for this shutdown is identical to “DC Bus Voltage Imbalance”, except that the shutdown has occurred during the precharge period. Refer to “DC Bus Voltage Imbalance” shutdown for possible problems. This shutdown will lockout the operation of the chiller on the first event.

Precharge - Low DC Bus Voltage

The LCD logic board determines this shutdown with information from the bus isolator board. This shutdown has two different timing events. First, the DC Bus voltage must be equal to or greater than 50 VDC four seconds after pre-charge has begun. Second, the DC Bus voltage must be equal to or greater than 500 VDC 19 seconds after pre-charge has begun. This shutdown is important to determine if the converter or the cap. bank is shorted.

Possible Problems:

- The LCD logic board is not getting bus voltage information. Place a DC volt meter at J3 on the LCD logic board pins 1 and 3. Start the chiller. If the voltage does not come up, then verify the wiring between the bus voltage isolation board, LCD logic board, and the laminated bus structure.
- Shorted cap. bank. Place a DC volt meter across the laminated bus structure. Try to start the chiller while measuring the voltage. If voltage is present, then the caps. are not shorted. If voltage is not present, then take an ohm meter and verify if the cap. bank is shorted or not.
- The converter is not being told to turn on. Verify that J4 on the SCR trigger board is properly installed. Verify that J11 on the LCD logic board is properly installed. Measure the DC voltage at J4 on the SCR trigger board pin 3 to ground. The voltage should go to 0 VDC when the drive enters precharge. If this does not happen, then verify the wiring between the SCR trigger board and the LCD logic board.
- The converter is not turning on. Verify the wiring between the SCR trigger board and the SCR gates. Also verify the wiring between

L1-L3 on the SCR trigger board and L1-L3 to the input of the drive at the input fuses and to the SCR anode connection.

- Measure the DC voltage at J1-J3 on the SCR trigger board. The voltage should be 1-3 VDC when the drive enters precharge. If the voltage is around 15 VDC, then the SCR trigger board has failed or the SCR gate is open. If the voltage is 0 VDC, the SCR trigger board had failed or the SCR gate is shorted.

Single Phase Input Voltage

This shutdown is generated by the SCR Trigger board and relayed to the LCD logic board to initiate a unit shutdown. The single phase control uses circuitry to detect the loss of any one of the three input phases. The trigger board will detect the loss of a phase within one half line cycle of the phase loss. An LED on the SCR Trigger board will indicate that the board is detecting the fault, and not a wiring problem between the trigger board and the LCD logic board. This shutdown is always an auto-restart when the shutdown has cleared.

Possible Problems:

- This message is typically displayed every time power to the LCD is restored or if the input power dips to a very low level. This is not an indication of a problem with the LCD.
- Verify the input fuses to the LCD. Failure of these fuses may indicate that there is another problem in the LCD.
- Verify the input fuses to the trigger board.
- Verify that the signal phase LED is lit.
- Verify the wiring between the J4 connector on the SCR trigger board and the J11 connector on the LCD logic board. A loose connector or a bad wiring connection can cause this shutdown.

VSD Communications Failure

At power-up, the LCD logic board will go through a process called initialization. At this time, memory locations are cleared, jumper positions are checked, and the serial communication link is established between the LCD logic board, and the chiller control logic board. If at any time the chiller control logic board does not receive valid data from the LCD logic board for a period of 8 seconds this shutdown will occur.

Possible Problems:

- Verify that the communication wiring is properly

installed between the LCD logic board at J12 and the chiller control logic board at J2. Ensure that the shield is only connected at the chiller control logic board. Check for continuity and also check to see that none of the conductors are shorted together or shorted to ground.

- Verify that the Mod Bus address jumper is properly installed in J5 of the LCD logic board. The default address is address #1. The table below shows the jumper locations in J5 for all of the available address. The chiller control must be programmed for the same address as the LCD logic board.

LCD Logic Board MODBUS Address	LCD Logic Board Jumper Position
1	J5-1 to J5-2 J5-3 to J5-4
2	J5-3 to J5-4
3	J5-1 to J5-2
4	None

- The EPROMs must be correct for each board, and they must be correctly installed. There are a total of three EPROMs in each chiller control center. All pins must be properly inserted into the EPROM sockets. Refer to the Software Reference List near the back of the form.
- The chiller control logic board and the LCD logic board must be energized at the same time. The practice of pulling the fuse in the control center to make wiring changes will create a problem. Power-up must be done by closing the main disconnect on the chiller control center with all fuses in place.
- Ensure that the chiller system is properly grounded for electrical noise. The LCD is the source of ground for the chiller. Ground is then conducted to the rest of the chiller by the mounting connections of the LCD. All connections are to be made with external tooth lock washers. These washers will cut through the paint on the chiller and provide a ground connection. The grounding system is critical for proper communications.
- Ensure that the chiller control logic board is properly ground to the mounting plate. Also, ensure that the mounting plate is properly grounded to the chiller control center enclosure.
- If all of this has been done and communications can never be established, even at power-up, you may have a bad communications driver on

either the LCD or the chiller control logic boards. Change out the 485 drivers on both the LCD and the chiller control logic boards.

VSD CT Plug Fault

This shutdown is generated by the LCD logic board. The J1 and J2 connectors on the LCD logic board contains jumpers that interconnect the 2 connectors. If any one of the connectors is loose or missing a fault will occur. This ensures that the LCD always has current feedback information from each compressor motor.

Possible Problems:

- The wire jumpers on connector J1 sockets 7 or 8, or connector J2 sockets 7 or 8 on the LCD logic board may not be properly installed, loose, or missing. Also verify that the sockets are not spread out. It may also be possible that the socket is not properly installed in the housing.

VSD Logic Board Failure

This shutdown is generated by the LCD logic board. If a communications problem occurs between the two microprocessors on the LCD logic board. This fault is only verified during precharge and run condition.

Possible Problems:

- If this shutdown should occur, replace the LCD logic board.

VSD Logic Board Power Supply

This shutdown is generated by the LCD logic board, and it indicates that one of the low voltage power supplies for the LCD logic board has dropped below their allowable operating limits. The power supplies for the logic boards are derived from the secondary of the 120 to 24 VAC transformer (Fig. 2) which in turn is derived from the 480 to 120 VAC control transformer (Fig. 2).

Possible Problems:

- This message normally appears when the power is removed and reapplied. This is not a failure, but the rest of the steps should be followed if this shutdown persists.
- The small control transformer that provides power to the LCD logic board has failed. Measure the output of the transformer with a DVM. The voltage should be between 24 – 32 VAC. These transformers are internally fused. If the fuse fails the transformer must be replaced.

- The input voltage to the small control transformer is too low. Measure the input voltage of the transformer with a DVM. The voltage should be between 108 – 132 VAC.
- Verify the power supply connector J4 at the LCD logic board.
- A power supply on the LCD logic board may have failed. Measure the DC voltage test points on the LCD logic board at TP1 (+15V), TP3 (+5V), TP4 (+7.5V), TP5 (-15V) and TP7 (-5V) with respect to TP6 (Ground). If any of these voltages are incorrect, replace the LCD logic board.

SYSTEM SHUTDOWNS

General Information

The System Shutdowns are organized in alphabetical order based on the Chiller Control Center messages.

Whenever a System Shutdown is generated by the LCD a series of events will occur.

- Any shutdown that occurs while the chiller is not running will cause a start inhibit for that system. That chiller system cannot be started until the shutdown has been cleared.
- If the chiller is running when the shutdown occur the LCD logic board will turn off the IGBT gate drivers for the failed system.
- The fault relay for the faulted system on the LCD logic board will de-energize causing an open circuit between J10-3 and J10-4. This action will indicate to the Chiller Control Center that the LCD has shutdown. The fault relay will remain de-energized until the Chiller Control board has acknowledged the cause of the shutdown. Once the Chiller Control board has acknowledged the shutdown the fault relay will close.
- The LCD logic board will send a shutdown code via the serial communications link to the Chiller Control board. The Chiller Control board will interpret the shutdown code, and display a shutdown message on the display of the Chiller Control Center.

After the reason for the shutdown has been corrected, the chiller may auto restart, but will lock out the operation of the chiller if the same shutdown were to occur 3 times within a 90-minute window unless otherwise noted in the shutdown information.

Gate Driver

The LCD has two methods of detecting an over current condition. One is from the output current transformers and the second is the gate driver fault. The gate driver fault is detected on the gate driver board. The collector-to-emitter voltage of each IGBT is checked while the device is turned on. This is also called the collector-to-emitter saturation voltage. If the voltage across the IGBT is greater than a set threshold as defined on the gate driver board, the IGBT is turned off and a shutdown pulse is sent to the LCD logic board shutting down the chiller system. This fault can indicate that too much current is flowing through the IGBT. This fault can also be caused if an IGBT is not being turned on when it should.

Possible Problems:

- A power supply problem on the IGBT gate driver board. Verify that the 6 LED's on each IGBT gate driver board are lit. The IGBT gate drive board is located on top of the IGBT module. If one of the six LED's is not lit, then the IGBT gate driver board has failed and requires replacement of the LCD power module. Refer to figure #4.
- The IGBT is shorted. Follow the procedure for failure of the LCD IGBT Module found later in this form.
- A failure in the switching power supply on the SCR trigger board. None of the LED's will be lit on the IGBT gate drive board. To verify this problem. Measure the DC voltage at TPF and TPG to ground on the SCR trigger board. The voltage at TPF should be 12.3 VDC. The voltage at TPG should be 12.8 VDC.
- Verify that the 7.5 VDC and 5 VDC power is getting to the IGBT gate driver board. Measure 7.5 VDC at J1 pin 14 and 5.0 VDC at J1 pin 8 on the IGBT gate drive board for the system that is faulted. The 7.5 VDC power is only present when the chiller is running. If the power supply or supplies are not present then verify the wiring and connectors between the LCD logic board, SCR trigger board and the IGBT gate driver board.
- A failure may have occurred on the LCD logic board. Switch the J6 connector compressor #1 and J8 connector compressor #2. These connectors are keyed with an extra pin, remove and save the pin. Also switch the 2 connectors for the current transformers. They are located just below the current transformers. By doing this, we have switched the IGBT gate driver

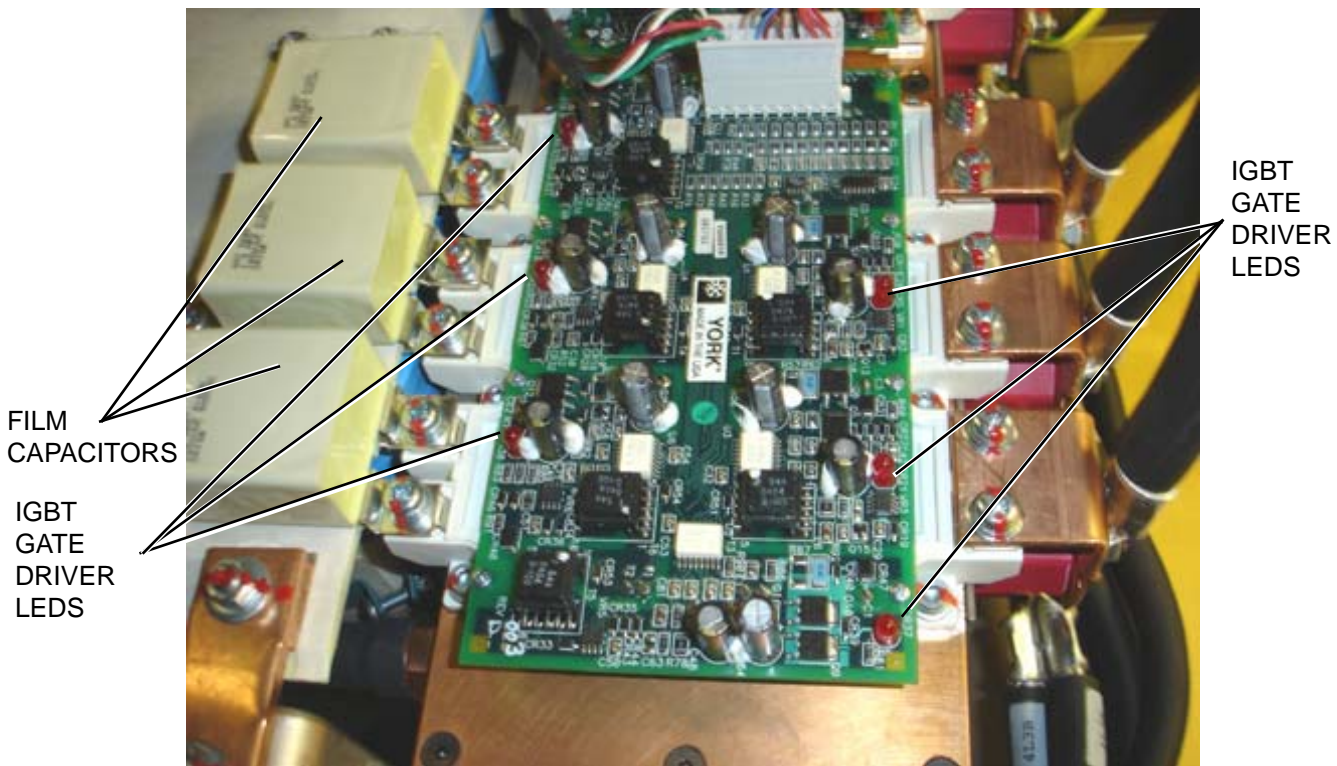

FIG. 4 – IGBT GATE DRIVER BOARD

50047

circuit on the logic board, but running the same IGBT module. If the fault was on compressor #1, then start compressor #2. If the fault repeats on compressor #1, then the LCD logic board is at fault. If no fault is present the logic board is okay. If a fault occurs on compressor #2 the logic board is okay. Replace all connectors and keys in their proper locations.

- The fault could also be caused by a problem in the compressor or motor. Switch the J6 connector compressor #1 and J8 connector compressor #2. These connectors are keyed with an extra pin, remove and save the pin. Switch the output motor wiring from one IGBT module to the other. By doing this we are switching which motor is being run with the same IGBT module. If the fault was on compressor #1, then start compressor #2. If no fault is present the IGBT module is okay, and the motor or compressor have a problem. If a fault occurs on compressor #2, then the IGBT module, or gate driver board has failed and must be replaced. Replace all connectors and keys in their proper locations.

High Motor Current

This shutdown is generated by the LCD logic board. If any one phase of motor current as measured by the Output Current Transformers exceeds 575 amps peak a shutdown will occur. The current values displayed are averaged RMS. In other words, the displayed current will never read 575 amps, but an elevated current value may be observed.

If a High Motor Current shutdown occurs, but the chiller restarts and runs without a problem, the cause may be attributed to a voltage sag on the utility power feeding the LCD that exceeds the specified dip voltage rating for this product. This is especially true if the chiller was running at, or near, full load. If there is a sudden dip in line voltage, the current to the motor will increase, since the motor wants to draw constant horsepower. The change in the output current due to an input power fluctuation is a very quick event on the order of several line cycles. The chiller cannot unload quickly enough to correct for this sudden increase in current, and the chiller will trip on this fault.

Possible Problems:

- Normal condition if a large power consuming device is started, such as another chiller, or large machinery. If this is the case then the chiller will auto restart.

- Shorted LCD power unit. Perform troubleshooting check for Failure of the LCD Power Module.
- A failure may have occurred on the LCD logic board. Switch the J6 connector compressor #1 and J8 connector compressor #2. These connectors are keyed with an extra pin, remove and save the pin. Also switch the 2 connectors for the current transformers. They are located just below the current transformers. By doing this, we have switched the IGBT gate driver circuit on the logic board, but still running the same IGBT module. If the fault was on compressor #1, then start compressor #2. If the fault repeats on compressor #1, then the LCD logic board is at fault. If no fault is present the logic board is okay. If a fault occurs on compressor #2 the logic board is okay. Replace all connectors and keys in their proper locations.
- Power supply failure on the IGBT gate driver board. Ensure that all 6 LED's are lit on the IGBT gate driver boards. If one is not lit, then the IGBT module and gate driver board must be replaced. Refer to figure #4.
- Failure of an output current transformer. Disconnect the connector for the output current transformers. Take an ohm reading at the connector. Each current transformer should have a $125 \pm 15\%$ ohm reading. **Note: Readings at connectors should be taken from the back of the connector so that the socket is not spread apart.** If the reading is within range, then reinstall the connector.
- Failure of an output current transformer. Remove the wiring from 1 current transformer at the connector just below the current transformers. Install a jumper into the 2 removed wires. Start the system with the high motor current fault. If no fault is present, then the phase where the current transformer was removed has a problem. If the fault is present reinstall the removed current transformer and remove another current transformer. Only one current transformer should be out of the circuit at a time.

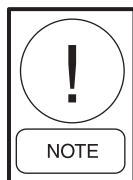

At no time should a current transformer be left with an open circuit. Also at no time should a system run without a current transformer in the circuit. The compressor motor should normally always have over current protection on all 3 phases.

Remove the motor wires from the IGBT module with the high current problem note the correct phasing. Remove the 3 current transformers noting the phase that reads the high current. Remove the current transformer from the phase with the high current, and install one of the other current transformers on this phase. Reinstall the motor wiring with the correct phasing. Start this system. If the LCD does not fault, then the removed current transformer has failed. If the LCD does fault, then the problem is in the motor or compressor. Be sure to reconnect all wires to their correct locations.

- Shorted motor, Meg the motor phase to phase and phase to ground. ***Wiring between the LCD and the motor must be disconnected before megging the motor. LCD failure may result if motor wires are not removed.***
- The motor or compressor has a locked rotor.
- Verify the operation of the economizer valve, drain valve, feed valve, and the controls for these valves.

High VSD Baseplate Temperature

A thermistor sensor is located inside each IGBT Module on the LCD power unit. A 5K ohm at 77°F thermistor is used. The thermistor resistance is read on the J1 connector of the IGBT gate driver board on pin 6 and 15. Remove the connector from the gate driver board and take the measurement on the board. If at anytime this thermistor detects a temperature of 218°F (103°C) or higher a shutdown will occur. The internal cooling fans and coolant pump will continue to run after the shutdown, until the thermistor temperature has dropped to below 203°F (95°C). Refer to Table 1 for detailed thermistor values.

Possible Problems:

- Improper coolant level for the drive. Remove the fill plug and verify that the coolant is 12 inches from the top of the pipe. This much open area is needed to allow for expansion of the coolant.
- A failure in the condenser fan system such as: fan blade, fan motor, fan contactor, output relay board or wiring.
- A failure in the coolant pump system such as: coolant pump, open fuse, pump motor, wiring or relay..
- No thermal grease used on the IGBT module.

TABLE 1 - LCD - THERMISTOR CHARACTERISTICS

TEMP°F NOMINAL	TEMP°C NOMINAL	R-THERMISTOR in ohms *
40	4.4	11314
45	7.2	10080
50	10.0	8996
55	12.8	8031
60	15.6	7193
65	18.0	6447
70	21.1	5793
75	23.9	5212
80	26.7	4698
85	29.4	4242
90	32.2	3835
95	35.0	3471
100	37.8	3150
105	40.5	2859
110	43.3	2602
120	48.9	2162
130	54.4	1807
140	60.0	1515
150	65.6	1278
160	71.1	1085
170	76.7	924
180	82.2	791
190	87.8	679
200	93.3	587
210	98.9	508
220	104.4	442

The IGBT module requires that a thin layer of thermal grease be used to aid in the removal of heat.

- Clogged chill plate.
- The SCR module or the IGBT module is not properly torque. The proper torque value is 48 in.-lbs. or 5.5 Nm



DO NOT insert the probes of the ohm meter into any connectors. This will cause the sockets in the connectors to spread apart and cause an intermittent connection. Instead insert the probes into the back of the connector.

Motor Current Overload

This shutdown is generated when the LCD logic board has detected that the highest of the three output phase currents for any compressor has exceeded 105% of the programmed 100% full load amps (FLA) value for more than 10 seconds.

The 100% FLA setpoint is determined by adjustment of the FLA trim pots on the LCD logic board. Each compressor motor has its own trim pot. This shutdown will lockout the operation of the chiller on the first event.

Possible Problems:

- FLA value not properly set for the application of each compressor.
- Excessive condenser pressure.
- Restriction in the refrigerant circuit.
- The economizer valve not working properly or stuck open.
- Feed and drain valves not working properly causing the compressor to overload.
- Failure of an output current transformer. The ohm value for the current transformer is 125 ohms \pm 15%.
- Refrigerant charge issues of being too low or too high.

VSD Run Relay

Two run signals are generated by the Chiller Control Board for each compressor system. One is through the communication system, and the other is through the wiring between the chiller control board the relay interface board and the LCD logic board. Upon receipt of either of the two run signals by the LCD logic board, a 5-second timer will begin on the LCD logic board. If the missing run signal is not received within the 5-second window the LCD logic board will shut down

Possible Problems:

- This shutdown could occur if there is a problem with the wiring between the Chiller Control Board and the LCD logic board. System #1 hardware run signal is sent on wire #113 to the LCD logic board at J10 pin 7. System #2 hardware run signal is sent on wire #213 to the LCD logic board at J10 pin 5.
- Verify that the serial communications wiring between the chiller control board, and the LCD logic board are connected properly.

WARNING MESSAGES

General Information

A WARNING message will indicate that the operation of the Latitude Compressor drive or chiller is affected in some manner, but the LCD is still functioning.

Invalid Number of Compressor Selected

This message is displayed when the compressor selection jumpers are not properly configured or missing. The jumpers are located on the J1 connector of the LCD logic board. The table below shows the correct connections for the different compressor quantities.

Number of Compressor	VSD Logic Board Jumper Position
2	J1-10 to J1-9
3	J1-11 to J1-9
4	J1-12 to J1-9

Possible Problems:

- Verify that the proper wire connections are made at the J1 connector as in the table above.
- Verify that the J1 connector is properly installed on the LCD logic board.
- Verify that all of the sockets are properly seated in the housing.

Start-Up Preparations

Circuit Breaker Setup

The circuit breaker used on the LCD has many settings for short circuit, and ground fault protection. Generally, these settings are adjusted by the manufacture, but these settings should be verified before starting the chiller. The rating plugs for the circuit breaker should be verified as well.

All 2 compressor LCD use the same circuit breaker settings, but the rating plugs are based on the input voltage range.

Name of Adjustment	Setting Value
• Short Delay Pickup	“2”
• Short Delay Time	“INST”
• Ground Fault Pickup	“1”
• Ground Fault Time	“150”

The settings for the circuit breaker should not be changed from the setting above. Warranty may be rejected if the circuit breaker is not properly set.

Rating plug for voltage ranges.

Input Voltage Range	Rating Plug Value
460, 575 VAC	600 Amp
380, 400 VAC	800 Amp
200, 230 VAC	1200 Amp

Verify Overload Settings

Refer to form 201.21-NM-1 for these settings.

VSD Frequently Asked Questions

Why doesn't the measured input amps of the LCD agree with the rated FLA?

The input current to the LCD may be considerably lower, compared to the output current. This is due to the power factor correction capability of the LCD. Chiller FLA must be measured at the motor terminals, where the power factor is the normal motor power factor. Use a true RMS reading meter to make these measurements.

How is the LCD cooled?

The LCD contains a liquid coolant loop that is directly connected to the condenser of the chiller. The loop is closed. A pump is used to move the coolant from and through the LCD and the condenser. On hot days when the chiller is not running the coolant pump may turn on to ensure that the LCD internal temperature is maintained at an acceptable level. The coolant is a long life inhibited propylene glycol solution formulated specifically for the LCD system.

Why are condenser fans running when the chiller is not?

It is possible on a hot sunny day that the internal temperature of the LCD may exceed the shutdown value. In this case, the chiller will not be available to run. To maintain the internal temperature at an acceptable level the coolant pump is turned on. If the coolant pump does not maintain the internal temperature, then the coolant pump and the first stage condenser fans will turn on.

How often should the coolant be changed?

The coolant should be changed every 5 years.

What is the function of the TEST Button on LCD Logic Board?

When the LCD is not running, this button may be used to test the operation of the logic outputs to the LCD power module, as well as the operation of the gate driver board on the IGBT module. When this button is depressed, six output LEDs on the LCD logic board alternately light the three plus (+) LEDs, then the three minus (-) LEDs. At the same time, six LEDs on the gate driver board will alternate between dim and bright intensity. Several conditions can inhibit this test function:

- If any LCD fault exists.
- If the unit is in pre-charge.
- If the SCR trigger is enabled.
- If the LCD unit is running.
- A 4 minute timer is part of this function to ensure that the DC Link Voltage is discharged to a safe

level. This timer must time out before the Test Button will function. The timer will start when the LCD enters a stopped condition.

How is the RPM of the compressor motor controlled?

As with other YORK drive products the control of the RPM comes from the chiller control system. The chiller control board determines the optimum RPM of each compressor by monitoring the status of various chiller pressures and temperatures.

What is the maximum RPM of the compressor motor?

The maximum RPM of the compressor motor is a function of the size of the chiller, but does not exceed 7,000 RPM. This allows the compressor and motor to be directly coupled without the use of gears.

Troubleshooting and Component Replacement Procedures

General Information

The following procedures are designed to guide the service technician along the path that leads to the identification of a problem. The service technician should understand the operation of the Latitude Compressor Drive (LCD) and function of each major component. It is recommended that the service technician read and understand the information contained in this instruction prior to troubleshooting this product. Also, the service technician must understand the system interface, and be able to utilize system wiring diagrams to follow signal flow throughout the system. Due to the integration of the LCD and the chiller control system, a good working knowledge of the chiller control system is also necessary (Ref. Forms listed at the beginning of this form).

Several levels of documentation are required for the troubleshooting process. The LCD wiring diagram, supplied with every chiller is the top-level document. It provides the overall wiring and configuration. Sections of this instruction provide the required lower levels. Specifically, block diagrams provide signal flow and simplified representations of all board circuitry.

Begin the troubleshooting process by selecting the appropriate procedure. It is not necessary to sequentially perform all of them. Perform a procedure only if there is a problem with that function.

Verify Failure of the LCD IGBT Module

General Information:



Personnel not familiar with AC drives, and proper electrical safety procedures should not be working on this product.



Be certain the LCD has been de-energized for over five minutes, and then double check for presence of voltage using a VOM. The DC bus must be fully discharged.

- It is not necessary to remove any wiring to perform this test.
- This test will be conducted for an analog meter and a digital meter. The analog meter must be adjusted to ohms on the Rx1 scale, and the meter should also be adjusted for a 0 ohm reading with the probes connected together. The digital meter must be placed on the diode check scale. In this test, we are not looking for exact resistance measurements, but rather to verify if the semi-conductor switches are open or shorted.
- The details of this procedure are for the IGBT module used for compressor #2. All IGBT modules are tested in the same manner, using the right side of the IGBT module as a reference point.

Test Procedure:

- Place the positive probe of the meter on the first right hand terminal of the IGBT module at the bus structure. This is the negative bus connection. Place the negative probe of the meter on the first right hand terminal of the IGBT module. This is one phase of the motor output. The wire should be marked 201. An analog meter will read approximately 5-10 ohms. A digital meter will read approximately 0.36 VDC. Refer to Fig. 5
- Place the positive probe of the meter on the next terminal to the left on the IGBT module at the bus structure. This is the positive bus connection. The analog meter reading will be near full scale to the left of the meter movement. The digital meter reading will be OL. The 2 readings will take several seconds to stabilize.
- Place the positive probe of the meter on the 3rd right hand terminal of the IGBT module at the

- bus structure. This is the negative bus connection. Place the negative probe of the meter on the 3rd right hand terminal of the IGBT module. This is the next phase of the motor output. The wire should be marked 202. An analog meter reading will be approximately 5-10 ohms. The digital meter reading will be approximately 0.36 VDC.
- Place the positive probe of the meter on the 4th right hand terminal of the IGBT module at the bus structure. This is the positive bus connection. The analog meter reading will be near full scale to the left of the meter movement. The digital meter reading will be OL. The 2 readings will take several seconds to stabilize.
 - Place the positive probe of the meter on the 5th right hand terminal of the IGBT module. This is the negative bus connection. Place the negative probe of the meter on the 5th left hand terminal of the IGBT module. The wire should be marked 203. A analog meter reading will be approximately 5-10 ohms. A digital meter reading will be approximately 0.36 VDC.
 - Place the positive probe of the meter on the 6th right hand terminal of the IGBT module. This is the positive bus connection. The analog meter reading will be near full scale to the left of the meter movement. The digital meter reading will be OL. The 2 readings will take several seconds to stabilize.

0.35 VDC READING ON DIGITAL METER



FIG. 5 – IGBT MODULE VERIFICATION

50048

- Place the negative probe of the meter on the first right hand terminal of the IGBT module at the bus structure. This is the negative bus connection. Place the positive probe of the meter on the first right hand terminal of the IGBT module. This is one phase of the motor output. The wire should be marked 201. The digital meter reading will be OL. The analog meter reading will be near full scale to the left of the meter movement. The 2 readings will take several seconds to stabilize. Refer. to Fig. 6
- Place the negative probe of the meter on the next terminal to the left of the IGBT module at the bus structure. This is the positive bus connection. An analog meter reading will be approximately 5-10 ohms. A digital meter reading will be approximately 0.36 VDC.
- Place the negative probe of the meter on the 3rd right hand terminal of the IGBT module at the bus structure. This is the negative bus connection.

ANALOG METER
READING FULL SCALE

NEGATIVE PROBE
ON NEGATIVE
BUS CONNECTION

POSITIVE PROBE
ON OUTPUT MOTOR
WIRE 201

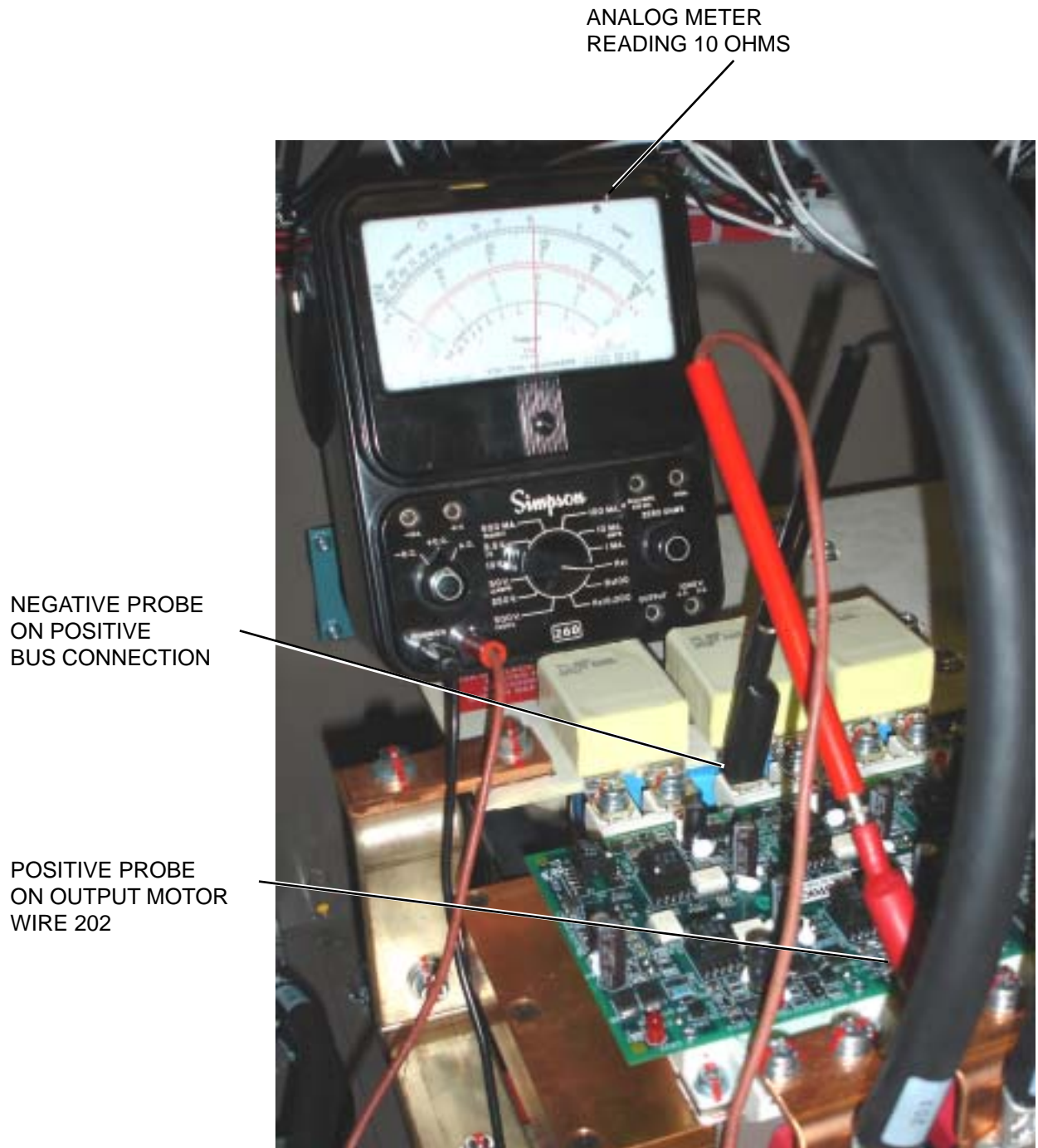

FIG. 6 – IGBT MODULE VERIFICATION #2

50049

tion. Place the positive probe of the meter on the 3rd right hand terminal of the IGBT module. This is the next phase of the motor output. The wire should be marked 202. The analog meter reading will be near full scale to the left of the meter movement. The digital meter reading will be OL. The 2 readings will take several seconds to stabilize.

- Place the negative probe of the meter on the 4th right hand terminal of the IGBT module at the bus structure. This is the positive bus connection. An analog meter reading will be approximately 5-10 ohms. A digital meter reading will be approximately 0.36 VDC. Ref. to Fig. 7.



50050

FIG. 7 – IGBT MODULE VERIFICATION #3

- Place the negative probe of the meter on the 5th right hand terminal of the IGBT module. This is the negative bus connection. Place the positive probe of the meter on the 5th right hand terminal of the IGBT module. The wire should be marked

203. The analog meter reading will be near full scale to the left of the meter movement. The digital meter reading will be OL. The 2 readings will take several seconds to stabilize. Ref. to Fig. 8

DIGITAL METER
READING OVERLOAD

NEGATIVE PROBE
ON POSITIVE
BUS CONNECTION

POSITIVE PROBE
ON OUTPUT MOTOR
WIRE 202

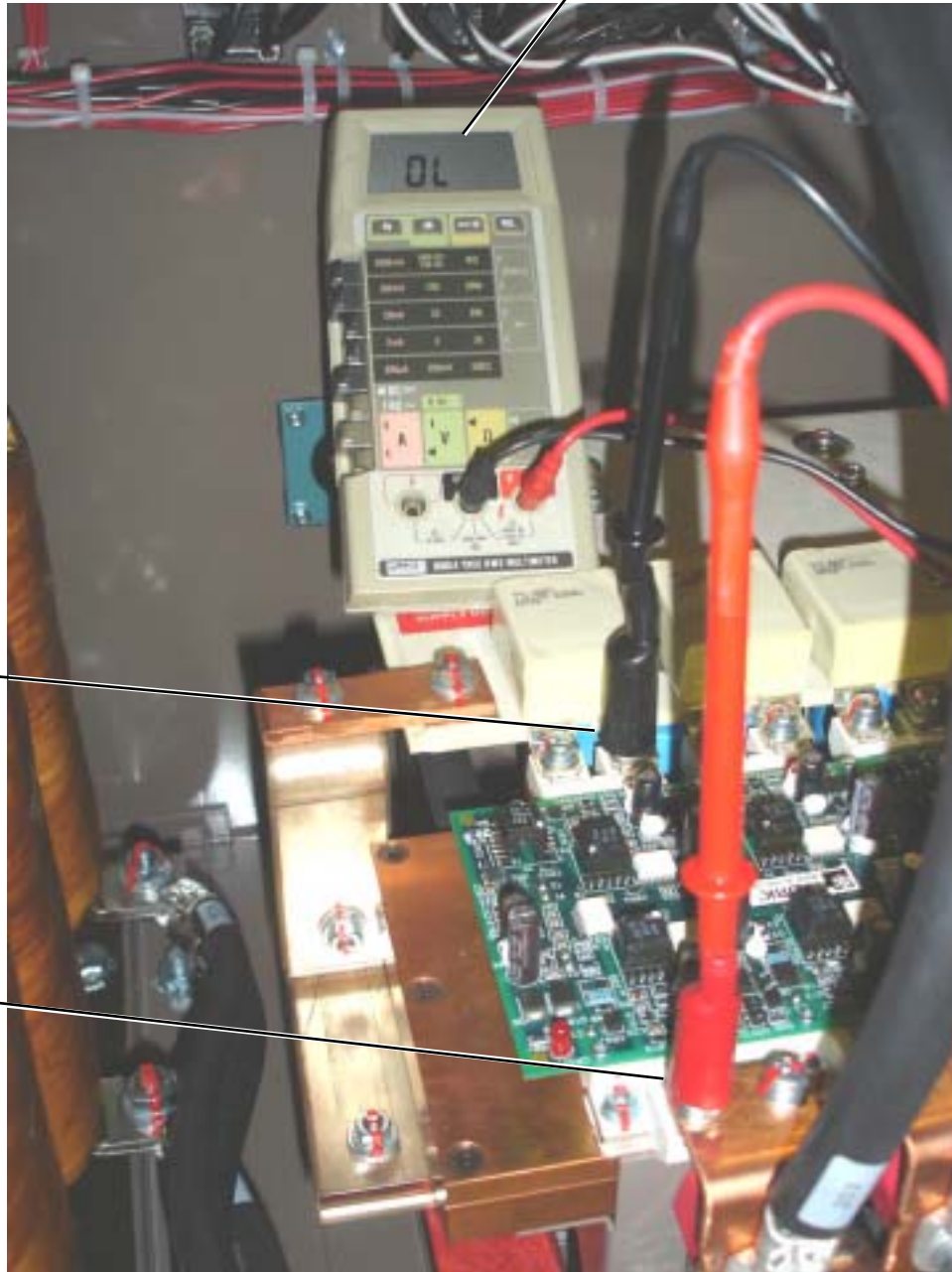

50051

FIG. 8 – IGBT MODULE VERIFICATION #4

- Place the negative probe of the meter on the 6th right hand terminal of the IGBT module. This is the positive bus connection. An analog meter reading will be approximately 5-10 ohms. A digital meter reading will be approximately 0.36 VDC.
- If any one of the readings is not correct, then the IGBT module and gate driver board must be replaced.

Verify Failure of the LCD SCR/Diode Module

General Information:



Personnel not familiar with AC drives, and proper electrical safety procedures should not be working on this product .



Be certain the LCD has been de-energized for over five minutes, and then double check for presence of voltage using a VOM. The DC bus must be fully discharged.

- It is not necessary to remove any wiring to perform this test.
- This test will be conducted for an analog meter and a digital meter. The analog meter must be adjusted to ohms on the Rx1 scale, and the meter should be adjusted for a 0 ohm reading with the probes connected together. The digital meter must be placed on the diode check scale. In this test we are not looking for an exact resistance measurements, but rather to verify if the semi-conductor switches are open or shorted.
- The details of this procedure are for the SCR/Diode module used for system #1. All SCR/Diode modules are tested in the same manner.

Test Procedure:

- Place the positive probe of the meter at the connection of the input line voltage and the SCR/Diode module the wire is marked 4L1. Place the negative probe on the bus bar to the right of the assembly. This is the positive bus. The analog meter reading will be near full scale to the left of the meter movement. The digital meter reading will be OL. The 2 readings will take several seconds to stabilize. Refer to Figs. 9 and 10.

ANALOG METER READING
FULL SCALE

NEGATIVE PROBE CONNECTED
TO POSITIVE BUS

POSITIVE PROBE
CONNECTED TO
INPUT WIRE 412



FIG. 9 – SCR / DIODE MODULE VERIFICATION #1

50052

- Reverse the position of the 2 probes. The analog meter reading will be near full scale to the left of the meter movement. The digital meter reading will be OL. The 2 readings will take several seconds to stabilize.
- Repeat this test for the other 2 input wire 4L2, and 4L3. The results should be the same as the above test.
- Place the positive probe of the meter at the connection of the input line voltage and the SCR/Diode module the wire is marked 4L1. Place the negative probe on the bus bar to the left of the assembly. This is the negative bus. An analog meter reading will be approximately 5-10 ohms. A digital meter reading will be approximately 0.36 VDC. Refer to Figs.11 and 12
- Reverse the position of the 2 probes. The analog meter reading will be near full scale to the left of the meter movement. The digital meter reading will be OL. The 2 readings will take several seconds to stabilize.
- Repeat this test for the other 2 input wire 4L2, and 4L3. The results should be the same as the above test.
- If a test for a SCR or diode fails, then that SCR/diode module will need to be replaced.

Replacement of the LCD IGBT Module

The following step by step procedure includes several helpful hints which should make the process easier, and minimize the possibility of damage to other components or to the LCD.

Save all of the packing material. This material is to be re-used when returning a defective power module as required for warranty.



Personnel not familiar with AC drives, and proper electrical safety procedures should not be working on this product .

POSITIVE PROBE CONNECTED
TO INPUT WIRE 4L2

NEGATIVE PROBE CONNECTED
TO POSITIVE BUS

DIGITAL METER
READING
OVERLOAD



50053

FIG. 10 – SCR / DIODE MODULE VERIFICATION #2

NEGATIVE PROBE CONNECTED TO INPUT WIRE 4L3

POSITIVE PROBE CONNECTED TO POSITIVE BUS



ANALOG METER READING 10 OHMS

FIG. 11 – SCR / DIODE MODULE VERIFICATION #3

50054

POSITIVE PROBE CONNECTED TO NEGATIVE BUS

NEGATIVE PROBE CONNECTED TO INPUT WIRE 4L2



DIGITAL METER READING 0.38 VDC

FIG. 12 – SCR / DIODE MODULE VERIFICATION #4

50055



Be certain the LCD has been de-energized for over five minutes, and then double check for presence of voltage using a VOM. The DC bus must be fully discharged.

- Remove the 18-pin connector on the IGBT Gate Driver Board.
- Remove and discard the 6 screws from the IGBT module at the motor output connector tangs, and the remaining 6 screws from the bus connections. Keep the 3 capacitors which will be reused.
- Remove the bolt holding the power wire to the output power tangs.
- Remove and discard the 8 screws holding the IGBT module in place.
- Carefully remove the IGBT power module by sliding it away from the bus structure while lifting slightly. **DO NOT** place any stress on the bus structure.
- Wipe the chill plate clean with a clean soft cloth. DO NOT leave lint or any materials on the chill plate. DO NOT clean using compressed air. Rubbing alcohol works well to remove the thermal grease from the chill plate.
- Apply a thin and even coat of thermal grease on to the back side of the IGBT module. The thermal grease should be provided in the service kit. The use of too much grease may cause IGBT failure.
- Place the new IGBT module on the chill plate so that the connector is towards the right of the LCD enclosure. Carefully slide the IGBT module power connections under the bus structure.
- Insert the 8 screws through the new IGBT module and engage a few threads in the chill plate, but DO NOT tighten. The new IGBT module should still be loose.
- Align the IGBT module so that 6 screws can be installed through the 3 square capacitors, then bus structure and into the IGBT module. DO NOT tighten these screws.
- Tighten the IGBT mounting screws to 48 in.-lbs. (5.5 Nm) \pm 10% in the sequence shown in Fig. #13.
- Install the 3 power wire connectors tangs using 6 screws, and torque the screws to 48 in.-lbs. (5.5 Nm) \pm 10%. Install the output power wire to the copper power tangs using the nut that was saved. Torque the bolt to 40-50 in.-lbs.

- The screws at the bus structure need to be tightened to 48 in.-lbs. (5.5 Nm) \pm 10%.
- Install the 18 pin connector on the IGBT Gate Driver Board.

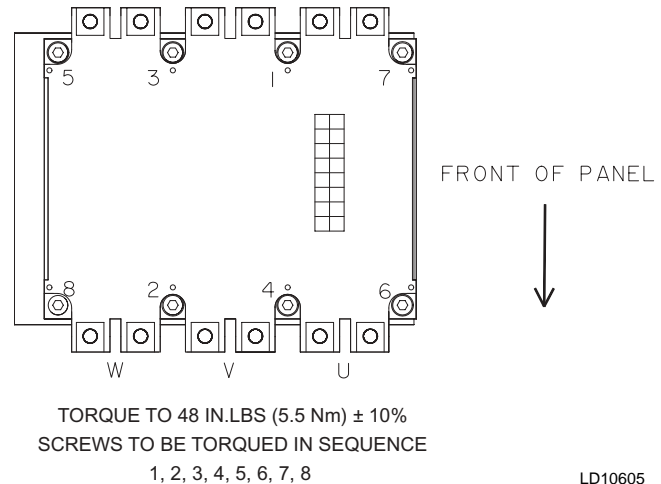

FIG. 13 – IGBT MODULE TORQUE SEQUENCE

Replacement of the LCD SCR/Diode Module

The following step by step procedure includes several helpful hints which should make the process easier, and minimize the possibility of damage to other components or to the LCD. Save all hardware, as it will be reused.



Personnel not familiar with AC drives, and proper electrical safety procedures should not be working on this product.



Be certain the LCD has been de-energized for over five minutes, and then double check for presence of voltage using a VOM. The DC bus must be fully discharged.

- Remove the bolt holding the input power wire to the copper tang.
- Remove the bolt holding the power tang to the SCR/diode module.
- Remove the 6 bolts between the 3 SCR/diode modules and the bus bars. Note the position of the bus bars.

- Remove hardware supporting the bus bars, and disconnect the bus bars from the bus structure on the left and right of the assembly.
- Remove the four Allen head mounting bolts from the failed SCR/diode module.
- Gently remove the gate wires from the SCR/diode module. Note locate of the gate wires.
- Wipe the chill plate clean with a clean soft cloth. DO NOT leave lint or any materials on the chill plate. DO NOT clean using compressed air. Rubbing alcohol works well to remove the thermal grease from the chill plate.
- Apply a thin and even coat of thermal grease on to the back side of the SCR/diode module. The thermal grease should be provided in the service kit. The use of too much grease may cause the SCR/diode module to fail.
- Gently install the gate wires onto the SCR/diode module. Ensure that these connections are tight. The white wire is installed toward the center of the module. Refer to Fig. 14.
- Place the new SCR/diode module on the chill plate install the 4 Allen head screws. Do not tighten the screws at this time.
- Reinstall the bus bars. Be sure that the bolt holes are aligned with the new SCR/diode module.

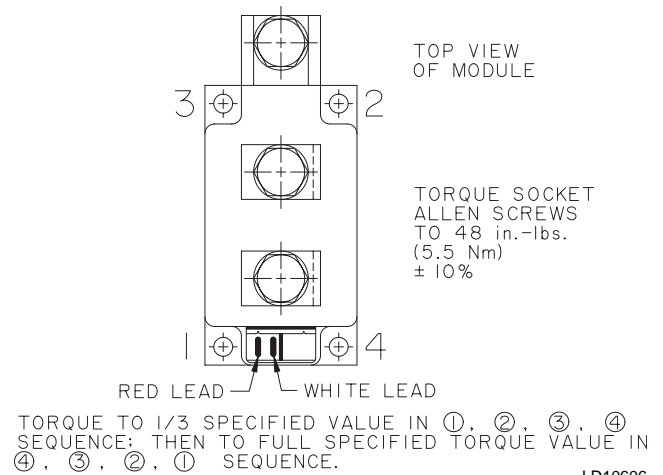

FIG. 14 – ISCR / DIODE MODULE TORQUE SEQUENCE

- Tighten the SCR/diode mounting screws to 48 in.-lbs. (5.5 Nm) $\pm 10\%$ in the sequence shown in Fig. 14.
- Tighten the all bus bar bolts to 88 in.-lbs. (10 Nm) $\pm 10\%$.
- Install the copper power tang to the SCR/diode module tighten the bolt to 88 in.-lbs. (10 Nm) $\pm 10\%$.
- Install the input power wire to the copper power tang using the nut that was saved. Torque the bolt to 88 in.-lbs. (10 Nm) $\pm 10\%$.

Software Reference List 50 Hz and 60 Hz

Location	Part Number	Latest Version Number
LCD Logic Board U36	031-02521-001	C.VSD.04.01
LCD Logic Board U39	031-02522-001	C.VSD.05.01
LCD Logic Board U41	031-02523-001	C.VSD.06.01

