



eco²
AIR COOLED SCREW LIQUID CHILLERS
MODELS YCAS STYLE 'F'

WIRING DIAGRAM

New Release

Form 201.18-W8 (1000)



Better ecology,
Better economy.

MODELS YCAS0295 THROUGH YCAS0605
50Hz



28971AR



TABLE OF CONTENTS

Nomenclature	3
Electrical Data (50 Hz)	4
Power Wiring Possibilities	10
Wiring Diagrams	12
Across-the-Line Start	12
Wye-Delta Start	16
Elementary Diagram	18
Connection Diagram	22
System Wiring	24
Compressor Terminal Box	25

WARNING

**HIGH VOLTAGE
is used in the operation of this equipment
DEATH OR SERIOUS INJURY
may result if personnel fail to observe precautions.**

Work on electronic equipment should not be undertaken unless the individual(s) has (have) been trained in the proper maintenance of the equipment and is (are) familiar with its potential hazards.

Shut off power supply to equipment before beginning work and follow lockout procedures. When working inside equipment with power off, take special care to discharge every capacitor likely to hold dangerous potential.

Be careful not to contact high voltage connections when installing or operating this equipment.

LOW VOLTAGE
DO NOT be misled by the term "low voltage". Voltages as low as 50 volts may cause death.

NOMENCLATURE

The Model Number denotes the following characteristics of the unit:

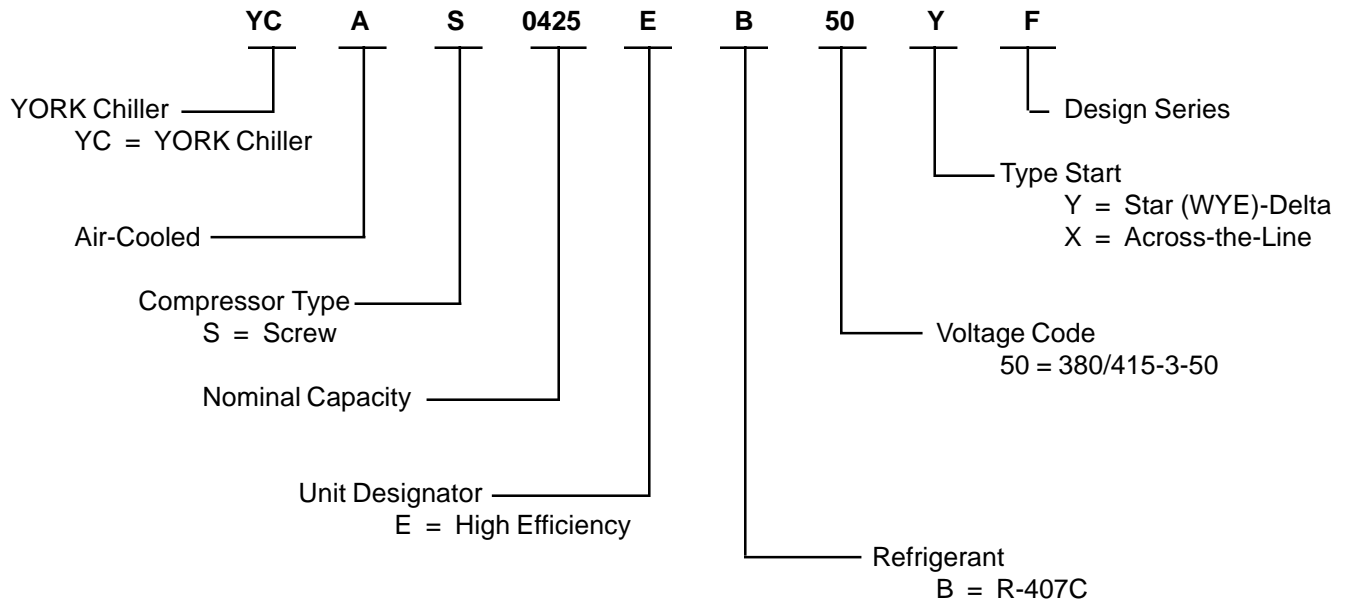

ELECTRICAL DATA (50 Hz)

MULTIPLE POINT POWER SUPPLY CONNECTION – 2 COMPRESSOR UNITS (SEE FIG. 1)

(Each of Two Field Provided Power Supply Circuits individually protected with Branch Circuit Protection.
Field Connections to Factory provided Terminal Block (Std), Disconnects (Opt), or Individual System Circuit Breakers* (Opt)
in each of the two Motor Control Centers.)

Model YCAS	Volts	ELECTRICAL SYSTEM #1 FIELD SUPPLIED WIRING												
		MRA ¹ (MCA)	Min. NF Disc. Sw. ^{2,9}	Overcurrent Protection ¹³		Factory Provided (Lugs) Wire Range ⁷			Compressor			Fans ^{11, 12}		
				Min. ^{3, 5}	Max. ^{4, 6}	*Standard Terminal Block	*Optional NF. Disc Switch	Optional Circuit Breaker	RLA	Y-LRA	X-LRA	Qty.	FLA (Ea.)	LRA (Ea.)
0295EB	380	114	150	150	175	# 2 - 4/0	# 4 - 300	# 4 - 300	79	183	552	3	4.8	23.0
0335EB	380	159	150	200	250	# 2 - 4/0	# 4 - 300	# 6 - 250	115	217	690	3	4.8	23.0
0375EB	380	159	150	200	250	# 2 - 300	# 4 - 300	# 6 - 250	115	217	690	3	4.8	23.0
0425EB	380	152	150	200	250	# 2 - 300	# 6 - 250	# 6 - 250	106	217	690	4	4.8	23.0
0475EB	380	205	200	250	350	2/0 - 500	# 6 - 300	(2) 3/0 - 250	148	267	857	4	4.8	23.0
0515EB	380	205	200	250	350	# 2 - 300	# 6 - 300	# 6 - 350	148	267	857	4	4.8	23.0
0555EB	380	255	250	350	400	2/0 - 500	# 6 - 350	(2) 3/0 - 250	188	267	857	4	4.8	23.0
0575EB	380	255	250	350	400	2/0 - 500	# 6 - 350	(2) 3/0 - 250	188	267	857	4	4.8	23.0
0605EB	380	241	250	300	400	2/0 - 500	# 6 - 350	(2) 3/0 - 250	173	267	857	5	4.8	23.0

* "Optional" Circuit Breakers are REQUIRED for units with CE mark.

See page 10 for Electrical Data Notes.

Model YCAS	Volts	ELECTRICAL SYSTEM #2 FIELD SUPPLIED WIRING												
		MRA ¹ (MCA)	Min. NF Disc. Sw. ^{2,9}	Overcurrent Protection ¹³		Factory Provided (Lugs) Wire Range ⁷			Compressor			Fans ^{11, 12}		
				Min. ^{3, 5}	Max. ^{4, 6}	*Standard Terminal Block	*Optional NF. Disc Switch	Optional Circuit Breaker	RLA	Y-LRA	X-LRA	Qty.	FLA (Ea.)	LRA (Ea.)
0295EB	380	114	150	150	175	# 2 - 4/0	# 4 - 300	# 4 - 300	79	183	552	3	4.8	23.0
0335EB	380	114	150	150	175	# 2 - 4/0	# 4 - 300	# 4 - 300	79	183	552	3	4.8	23.0
0375EB	380	159	150	200	250	# 2 - 300	# 4 - 300	# 6 - 350	115	217	690	3	4.8	23.0
0425EB	380	152	150	200	250	# 2 - 300	# 6 - 350	# 6 - 350	106	217	690	4	4.8	23.0
0475EB	380	152	150	200	250	# 1 - 500	# 6 - 350	(2) 3/0 - 250	106	217	690	4	4.8	23.0
0515EB	380	205	200	250	350	# 2 - 300	# 6 - 350	# 6 - 350	148	267	857	4	4.8	23.0
0555EB	380	205	200	250	350	# 1 - 500	# 6 - 350	(2) 3/0 - 250	148	267	857	4	4.8	23.0
0575EB	380	255	250	350	400	# 1 - 500	# 6 - 350	(2) 3/0 - 250	188	267	857	4	4.8	23.0
0605EB	380	241	250	300	400	# 1 - 500	# 6 - 350	(2) 3/0 - 250	173	267	857	5	4.8	23.0

ELECTRICAL DATA (50 Hz)

OPTIONAL SINGLE POINT POWER SUPPLY WITH INDIVIDUAL SYSTEM CIRCUIT BREAKERS – 2 COMPRESSOR UNITS (SEE FIG. 2)

One Field Provided Power Supply Circuit to the chiller. Field connections to Power Terminal Block or Non-Fused Disconnect in 'Option Panel'. Internal Branch Circuit Protection (Breakers) per Motor Control Center¹⁰.

CHILLER MODEL YCAS	FIELD-SUPPLIED WIRING					
	FIELD PROVIDED POWER SUPPLY				FACTORY PROVIDED (LUGS) WIRE RANGE ⁷	
	MRA ¹	MIN NF DISC SW ^{2,9}	OVER-CURRENT PROTECTION		STANDARD TERMINAL BLOCK	OPTIONAL NF DISC. SWITCH
			MIN. ^{3,5}	MAX. ^{4,6}		
0295EB	227	250	250	250	2/0 - 500	# 6 - 350
0335EB	272	400	300	350	2/0 - 500	(2) 3/0-250
0375EB	317	400	350	400	(2) # 2 - 300	(2) 3/0-250
0425EB	304	400	350	350	(2) # 2 - 300	(2) 3/0-250
0475EB	356	400	400	450	(2) # 1 - 500	(3) 2/0-400
0515EB	409	400	450	500	(2) # 2 - 300	(2) 3/0-250
0555EB	459	600	500	600	(2) # 1 - 500	(3) 2/0-400
0575EB	509	600	600	600	(2) # 1 - 500	(3) 2/0-400
0605EB	481	600	500	600	(2) # 1 - 500	(3) 2/0-400

See page 10 for Electrical Data footnotes.

CHILLER MODEL YCAS	ELECTRICAL SYSTEM #1							ELECTRICAL SYSTEM #2				
	COMPRESSOR DATA				FAN DATA ^{11, 12}			COMPRESSOR DATA			FAN DATA ^{11, 12}	
	RLA	Y-LRA	X-LRA	QTY	FLA (EA)	LRA (EA)	RLA	Y-LRA	X-LRA	QTY	FLA (EA)	LRA (EA)
0295EB	79.0	183.0	552.0	3	4.8	23.0	79.0	183.0	552.0	3	4.8	23.0
0335EB	115.0	217.0	690.0	3	4.8	23.0	79.0	183.0	552.0	3	4.8	23.0
0375EB	115.0	217.0	690.0	3	4.8	23.0	115.0	217.0	690.0	3	4.8	23.0
0425EB	106.0	217.0	690.0	4	4.8	23.0	106.0	217.0	690.0	4	4.8	23.0
0475EB	148.0	267.0	857.0	4	4.8	23.0	106.0	217.0	690.0	4	4.8	23.0
0515EB	148.0	267.0	857.0	4	4.8	23.0	148.0	267.0	857.0	4	4.8	23.0
0555EB	188.0	267.0	857.0	4	4.8	23.0	148.0	267.0	857.0	4	4.8	23.0
0575EB	188.0	267.0	857.0	4	4.8	23.0	188.0	267.0	857.0	4	4.8	23.0
0605EB	173.0	267.0	857.0	5	4.8	23.0	173.0	267.0	857.0	5	4.8	23.0

ELECTRICAL DATA (50 Hz)

OPTIONAL SINGLE POINT POWER SUPPLY CONNECTION – 2 COMPRESSOR UNITS (SEE FIG. 3)

One Field Provided Power Supply Circuit to the chiller. Field Connection to Power Terminal Block or Disconnect Switch in the 'Option Panel'.
No Internal System Circuit Breaker Protection per Motor Control Center¹⁰.

CHILLER MODEL YCAS	FIELD-SUPPLIED WIRING					
	FIELD PROVIDED POWER SUPPLY			FACTORY PROVIDED (LUGS) WIRE RANGE ⁷		
	MCA ¹	MIN NF DISC SW ^{2,9}	OVER-CURRENT PROTECTION ¹³		STANDARD TERMINAL BLOCK	OPTIONAL NF DISC. SWITCH
			MIN. ^{3,5}	MAX. ^{4,6}		
0295EB	227	250	250	250	2/0-500	# 6 - 350
0335EB	272	400	300	350	2/0-500	(2) 3/0-250
0375EB	317	400	350	400	(2) # 2 - 300	(2) 3/0-250
0425EB	304	400	350	350	(2) # 2 - 300	(2) 3/0-250
0475EB	356	400	400	450	(2) # 1 - 500	(3) 2/0-400
0515EB	409	400	450	500	(2) # 2 - 300	(2) 3/0-250
0555EB	459	600	500	600	(2) # 1 - 500	(3) 2/0-400
0575EB	509	600	600	600	(2) # 1 - 500	(3) 2/0-400
0605EB	481	600	500	600	(2) # 1 - 500	(3) 2/0-400

Option *NOT* available for units with CE mark.

See page 10 for Electrical Data footnotes.

OPTIONAL SINGLE POINT POWER SUPPLY CONNECTION TO FACTORY CIRCUIT BREAKER – 2 COMPRESSOR UNITS (SEE FIG. 4)

One Field Provided Power Supply Circuit to the chiller. Field connection to Circuit Breaker in "Option Panel".
No internal System Circuit Breaker Protection per Motor Control Center¹⁰.

CHILLER MODEL YCAS	FIELD SUPPLIED WIRING			SYSTEM #1					SYSTEM #2					
	MRA ¹	FACTORY SUPPLIED BREAKER		COMPRESSOR		FANS ^{11, 12}			COMPRESSOR		FANS ^{11, 12}			
		RATING ^{5,6}	WIRE RANGE ⁷ (LUGS)		RLA	X-LRA	QTY	FLA (EA)	FLA (EA)	RLA	X-LRA	QTY	FLA (EA)	LRA (EA)
0295EB	227	250	# 6 - 350		79.0	552.0	3	4.8	23.0	79	552.0	3	4.8	23.0
0335EB	272	400	(2) 3/0-250		115.0	690.0	3	4.8	23.0	79	552.0	3	4.8	23.0
0375EB	317	450	(2) 3/0-250		115.0	690.0	3	4.8	23.0	115	690.0	3	4.8	23.0
0425EB	304	500	(2) 3/0-250		106.0	690.0	4	4.8	23.0	106	690.0	4	4.8	23.0
0475EB	356	600	(3) 2/0-400		148.0	857.0	4	4.8	23.0	106	690.0	4	4.8	23.0
0515EB	409	500	(2) 3/0-250		148.0	857.0	4	4.8	23.0	148	857.0	4	4.8	23.0
0555EB	459	600	(3) 2/0-400		188.0	857.0	4	4.8	23.0	148	857.0	4	4.8	23.0
0575EB	509	700	(3) 2/0-400		188.0	857.0	4	4.8	23.0	188	857.0	4	4.8	23.0
0605EB	481	600	(3) 2/0-400		173.0	857.0	5	4.8	23.0	173	857.0	5	4.8	23.0

Option *NOT* available for units with CE mark.

See page 10 for Electrical Data footnotes.

CHILLER MODEL YCAS	SYSTEM #1					SYSTEM #2				
	COMPRESSOR DATA		FAN DATA ^{11, 12}			COMPRESSOR DATA		FAN DATA ^{11,12}		
	RLA	X-LRA	QTY	FLA (EA.)	LRA (EA)	RLA	X-LRA	QTY	FLA (EA)	LRA (EA)
0295EB	79	552	3	4.8	23.0	79	552	3	4.8	23.0
0335EB	115	690	3	4.8	23.0	79	552	3	4.8	23.0
0375EB	115	690	3	4.8	23.0	115	690	3	4.8	23.0
0425EB	106	690	4	4.8	23.0	106	690	4	4.8	23.0
0475EB	148	857	4	4.8	23.0	106	690	4	4.8	23.0
0515EB	148	857	4	4.8	23.0	148	857	4	4.8	23.0
0555EB	188	857	4	4.8	23.0	148	857	4	4.8	23.0
0575EB	188	857	4	4.8	23.0	188	857	4	4.8	23.0
0605EB	173	857	5	4.8	23.0	173	857	5	4.8	23.0

ELECTRICAL DATA

NOTES (pages 4 - 9)

1. MRA is Maximum Running Amps, the maximum continuous current at any operating point in the rating range. Also referred to as MCA, or Minimum Circuit Ampacity to be provided by the installer. If a Factory Mounted Control Transformer is provided, add 3 amps to the system #1 MCA values in the YCAS Tables.
2. The recommended disconnect switch is based on a minimum of 115% of the summation rated load amps of all the loads included in the circuit, per N.E.C. 440 - 12A1.
3. Minimum recommended fuse size is based on 150% of the largest motor RLA plus 100% of the remaining RLAs. Minimum fuse rating = (1.5 x largest compressor RLA) + other compressor RLAs + (# fans x each fan motor FLA).
4. Maximum dual element fuse size is based on 225% maximum plus 100% of the rated load amps for all other loads included in the circuit, per N.E.C. 440-22. Maximum fuse rating = (2.25 x largest compressor RLA) + other compressor RLAs + (# fans x each fan motor FLA).
5. Minimum recommended circuit breaker is 150% maximum plus 100% of rated load amps included in the circuit. Minimum circuit breaker rating = (1.5 x largest compressor RLA) + other compressor RLAs + (# fans x each fan motor FLA).
6. Maximum circuit breaker is based on 225% maximum plus 100% of the rated load amps for all loads included in the circuit, per circuit, per U.L. 1995 Fig. 36.2. Maximum circuit breaker rating = (2.25 x largest compressor RLA) + other compressor RLAs + (# fans x each fan motor FLA).
7. The Incoming Wire Range is the minimum and maximum wire size that can be accommodated by unit wiring lugs. The (1), (2), or (3) indicate the number of termination points or lugs which are available per phase. Actual wire size and number of wires per phase must be determined based on ampacity and job requirements using N.E.C. wire sizing information. The above recommendations are based on the National Electrical Code and using **copper connectors** only. Field wiring must also comply with local codes.
8. A ground lug is provided for each compressor system to accommodate field grounding conductor per N.E.C. Article 250-54. A control circuit grounding lug is also supplied.
9. The field supplied disconnect is a "Disconnecting Means" as defined in N.E.C. 100.B, and is intended for isolating the unit from the available power supply to perform maintenance and troubleshooting. This disconnect is not intended to be a Load Break Device.
10. Two-compressor machines with single-point power connection, and equipped with Star-Delta compressor motor start must also include Factory provided circuit breakers in each motor control center.
11. Consult factory for Electrical Data on units equipped with "High Static Fan" option. 50Hz High Static Fans are 3.5kW each.
12. FLA for each "Low Noise Fan" motor: 380v/50Hz = 4.1A.

LEGEND

ACR-LINE	ACROSS THE LINE START
CB	CIRCUIT BREAKER
DE FU	DUAL ELEMENT FUSE
DISC SW	DISCONNECT SWITCH
FACT MOUNT CB	FACTORY-MOUNTED CIRCUIT BREAKER
FACT MOUNT FUSE	FACTORY-MOUNTED FUSES
FLA	FULL LOAD AMPS
HZ	HERTZ
MAX	MAXIMUM
MCA	MINIMUM CIRCUIT AMPACITY
MIN	MINIMUM
MIN NF	MINIMUM NON-FUSED
RLA	RUNNING LOAD AMPS
S.P. WIRE	SINGLE-POINT WIRING
UNIT MTD SERV SW	UNIT-MOUNTED SERVICE (NON-FUSED DISCONNECT SWITCH)
WYE-DELTA	WYE-DELTA START
XLRA	ACROSS-THE-LINE INRUSH LOCKED ROTOR AMPS
YLRA	WYE-DELTA INRUSH LOCKED ROTOR AMPS

VOLTAGE CODE
50=380/415-3-50

CONTROL POWER SUPPLY (UNITS WITH STANDARD CONTROL CIRCUIT TRANSFORMERS)

NO. OF COMPRESSORS	CONTROL POWER SUPPLY	MCA (MAX LOAD CURRENT)	RECOMMENDED DUAL ELEMENT FUSE SIZE	NON-FUSED DISCONNECT SWITCH SIZE
2	400V - 50Hz	6.3A	15A	—
3 or 4	400V - 50Hz	9.4A	15A	—

CONTROL POWER SUPPLY (UNITS WITHOUT STANDARD CONTROL CIRCUIT TRANSFORMERS)

NO. OF COMPRESSORS	CONTROL POWER SUPPLY	MCA (MAX LOAD CURRENT)	MAX DUAL ELEMENT FUSE SIZE	NON-FUSED DISCONNECT SWITCH SIZE
2	115V-1Ø	20A	20A	30A
3 or 4 (Non-CE 50/60Hz)	115V-1Ø	30A	30A	30A
3 or 4 (CE 50Hz)	115V-1Ø	25A	30A	30A

POWER WIRING POSSIBILITIES

STYLE "F" 2 COMPRESSOR POWER WIRING CONNECTIONS

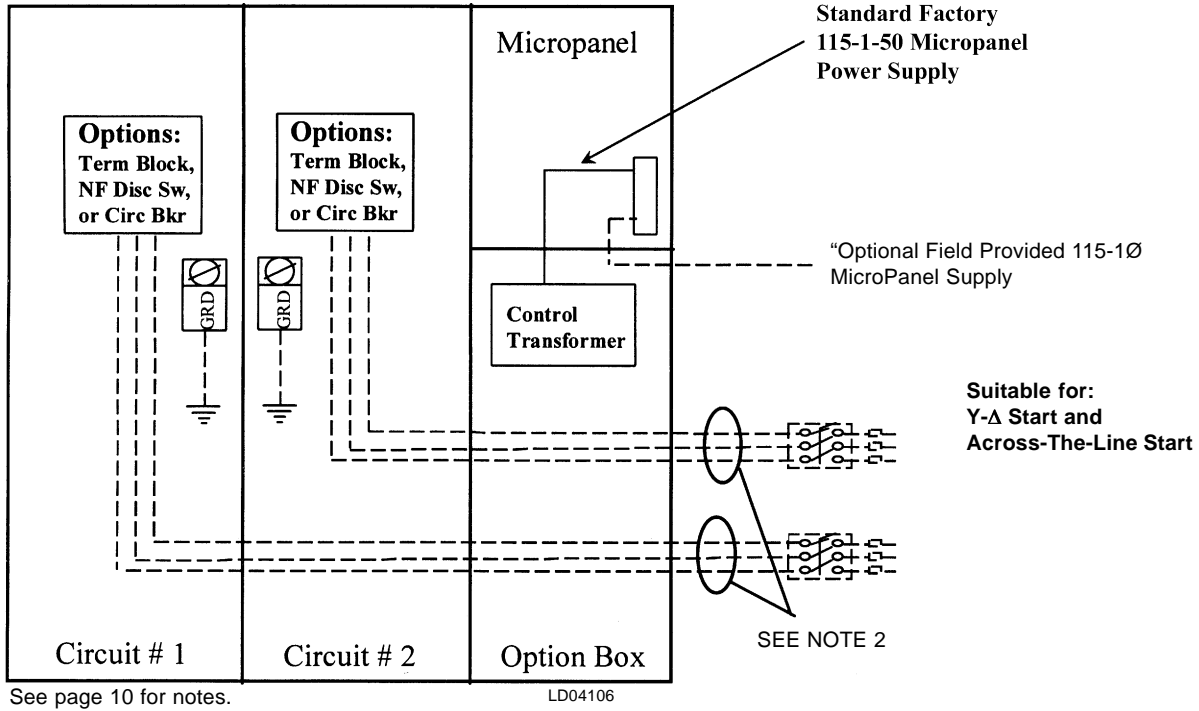

FIG. 1 – MULTIPLE POINT POWER SUPPLY CONNECTION – STANDARD UNIT

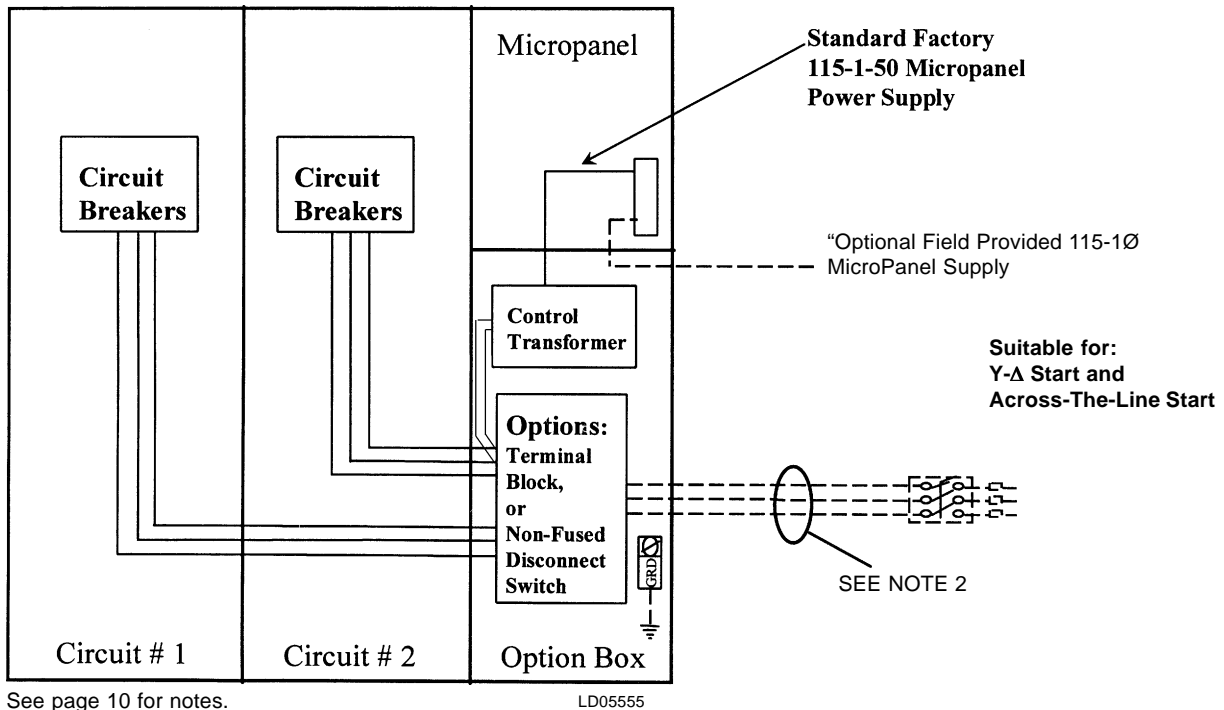

FIG. 2 – OPTIONAL SINGLE POINT POWER SUPPLY CONNECTION WITH INDIVIDUAL SYSTEM CIRCUIT BREAKERS

POWER WIRING POSSIBILITIES

STYLE "F" 2 COMPRESSOR POWER WIRING CONNECTIONS

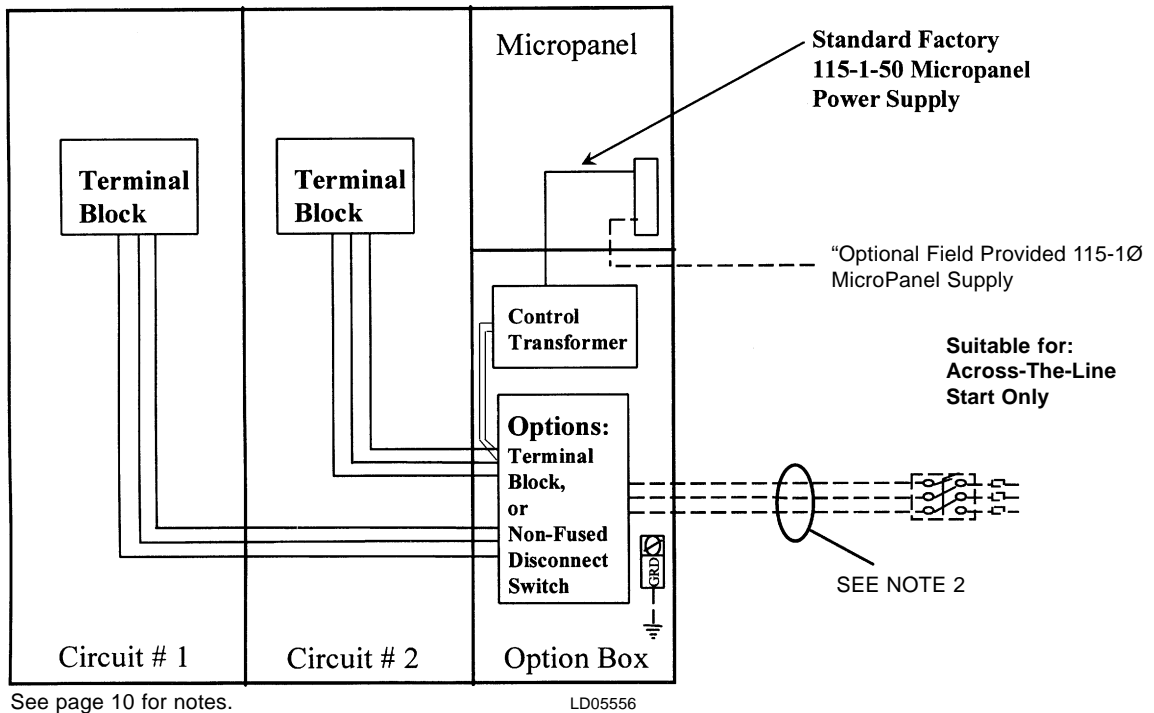

FIG. 3 – OPTIONAL SINGLE POINT POWER SUPPLY CONNECTION WITH FIELD SUPPLIED CIRCUIT PROTECTION

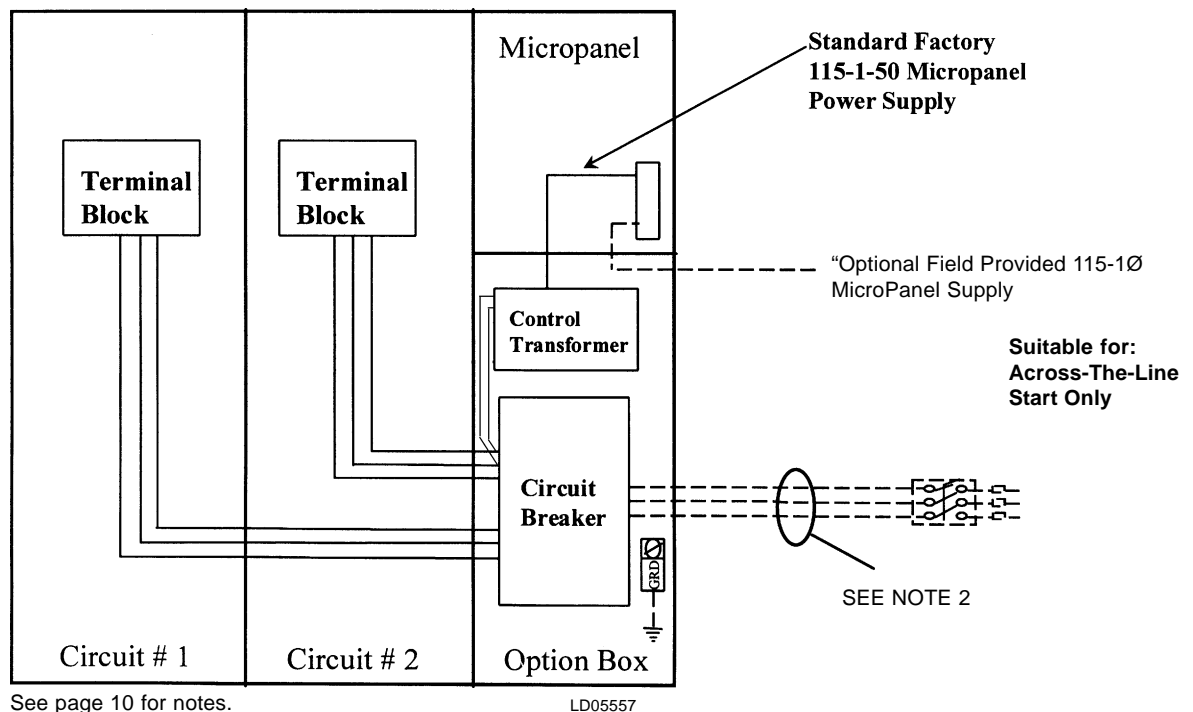
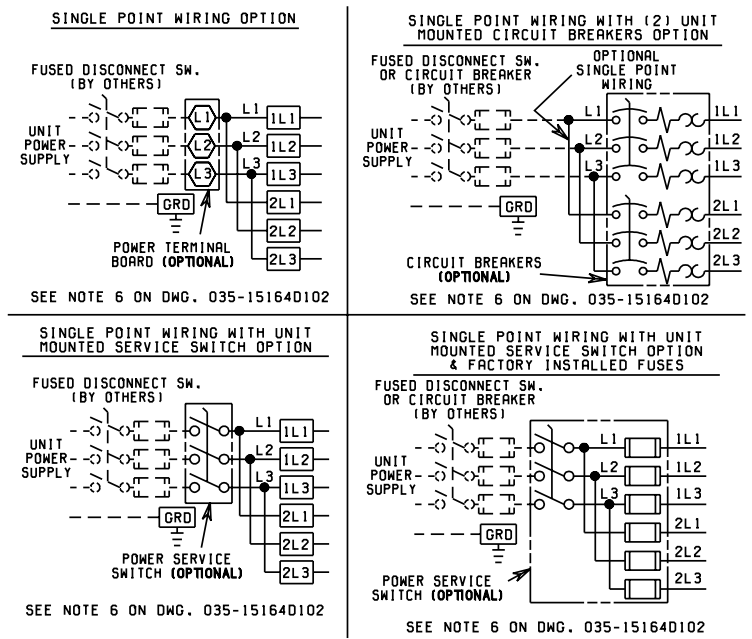

FIG. 4 – OPTIONAL SINGLE POINT POWER SUPPLY CONNECTION TO FACTORY CIRCUIT BREAKER

WIRING DIAGRAM ACROSS-THE-LINE START

NOTES:

1. Field wiring to be in accordance with the current edition of the National Electrical Code as well as all other applicable codes and specifications.
2. Numbers along the right side of a diagram are line identification numbers. The numbers at each line indicate the line number location of relay contacts. An unlined contact location signifies a normally closed contact. Numbers adjacent to circuit lines are the circuit identification numbers.
3. Any customer supplied contacts must be suitable for switching 24VDC. (Gold contacts recommended.) Control Wiring must not be run in the same conduit with any line voltage wiring.
4. To cycle unit on and off automatically with contact shown, install a cycling device in series with the flow switch (FSLW). See Note 3 for contact rating and wiring specifications. Also refer to cautions on the following page.
5. To stop unit (Emergency Stop) with contacts other than those shown, install the stop contact between 5 and 1. If a stop device is not installed, a jumper must be connected between terminals 5 and 1. Device must have a minimum contact rating of 100VA at 115 volts A.C.
6. Alarm contacts are for annunciating alarm/unit malfunction. Contacts are rated at 115V, 100VA, resistive load only, and must be suppressed at load by user.
7. See Installation, Operation and Maintenance Manual when optional equipment is used.
8. Control panel to be securely connected to earth ground.
9. Us 2KVA transformer in optional transformer kit unless there are optional oil separator sump heaters which necessitates using a 3KVA transformer.



LD03226

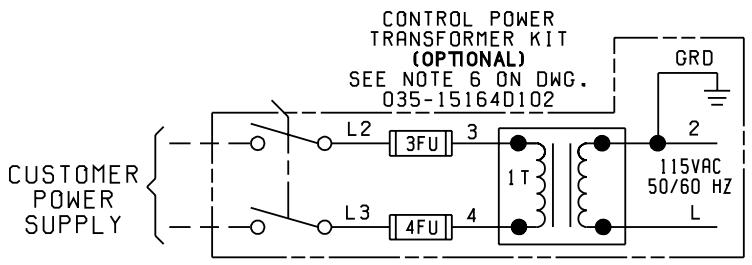

LD03227

LEGEND

- TS** Transient Voltage Suppression
- Terminal Block for Customer Connections
- Terminal Block for Customer Low Voltage (Class 2) Connections. See Note 2
- Terminal Block for YORK Connections Only
- Wiring and Components by YORK
- Optional Equipment
- Wiring and/or Components by Others

FIG. 5 – ELEMENTARY DIAGRAM – ACROSS-THE-LINE START

WIRING DIAGRAM ACROSS-THE-LINE START

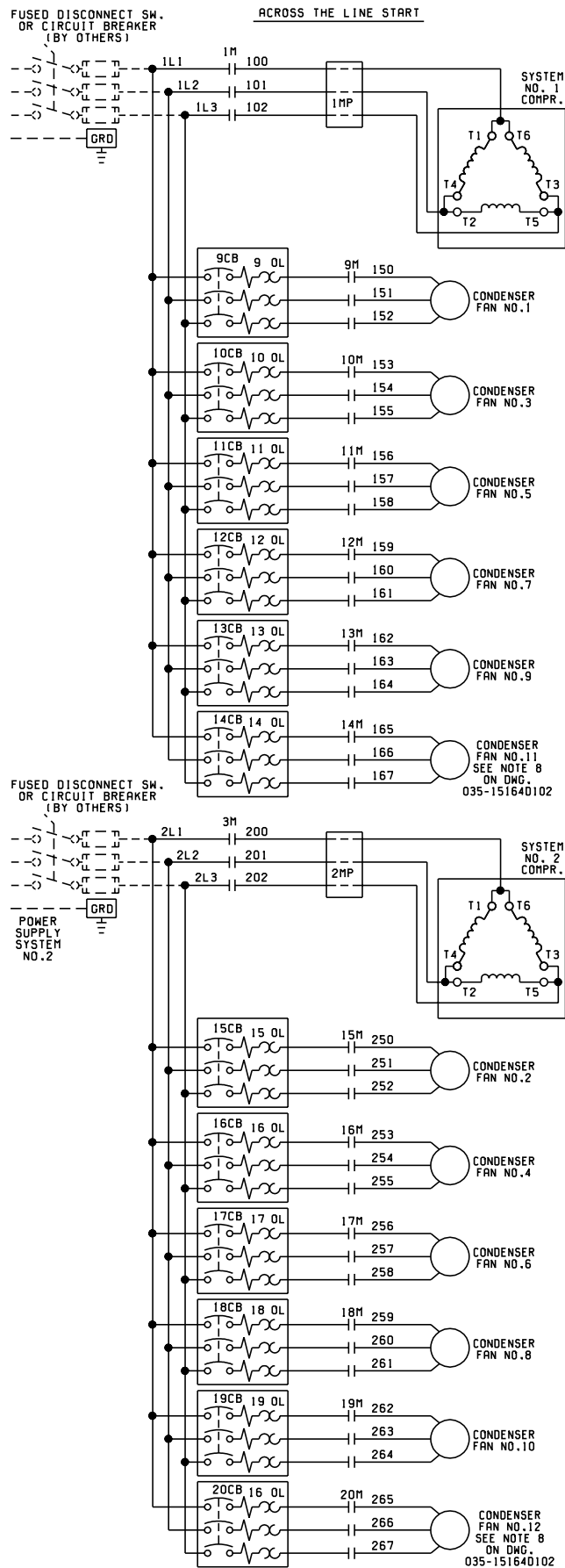

WIRING DIAGRAM ACROSS-THE-LINE START

NOTES:

1. Field wiring to be in accordance with the current edition of the National Electrical Code as well as all other applicable codes and specifications.
2. Numbers along the right side of a diagram are line identification numbers. The numbers at each line indicate the line number location of relay contacts. An unlined contact location signifies a normally closed contact. Numbers adjacent to circuit lines are the circuit identification numbers.
3. Any customer supplied contacts must be suitable for switching 24VDC. (Gold contacts recommended.) Control Wiring must not be run in the same conduit with any line voltage wiring.
4. To cycle unit on and off automatically with contact shown, install a cycling device in series with the flow switch (FSLW). See Note 3 for contact rating and wiring specifications. Also refer to cautions on the following page.
5. To stop unit (Emergency Stop) with contacts other than those shown, install the stop contact between 5 and 1. If a stop device is not installed, a jumper must be connected between terminals 5 and 1. Device must have a minimum contact rating of 100VA at 115 volts A.C.
6. Alarm contacts are for annunciating alarm/unit malfunction. Contacts are rated at 115V, 100VA, resistive load only, and must be suppressed at load by user.
7. See Installation, Operation and Maintenance Manual when optional equipment is used.
8. Control panel to be securely connected to earth ground.
9. Us 2KVA transformer in optional transformer kit unless there are optional oil separator sump heaters which necessitates using a 3KVA transformer.

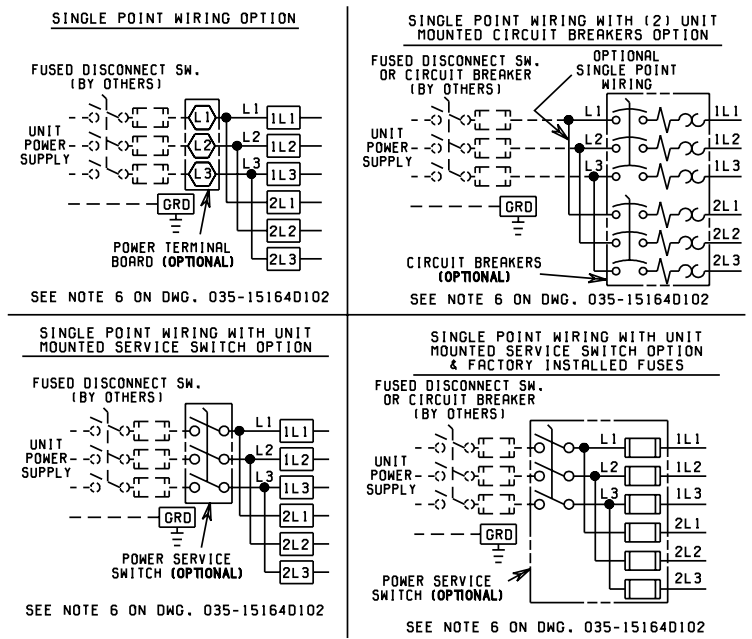

LD03226

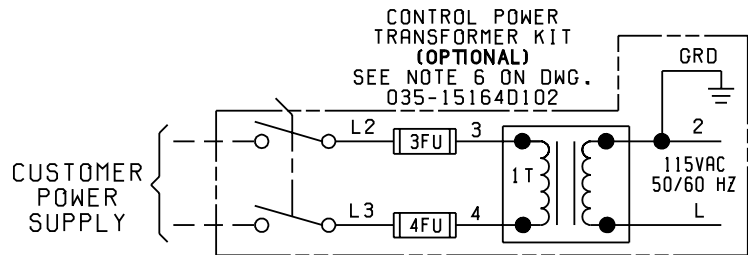

LD03227

LEGEND

- TS** Transient Voltage Suppression
- Terminal Block for Customer Connections
- Terminal Block for Customer Low Voltage (Class 2) Connections. See Note 2
- Terminal Block for YORK Connections Only
- Wiring and Components by YORK
- Optional Equipment
- Wiring and/or Components by Others

FIG. 6 – ELEMENTARY DIAGRAM – ACROSS-THE-LINE START

WIRING DIAGRAM ACROSS-THE-LINE START

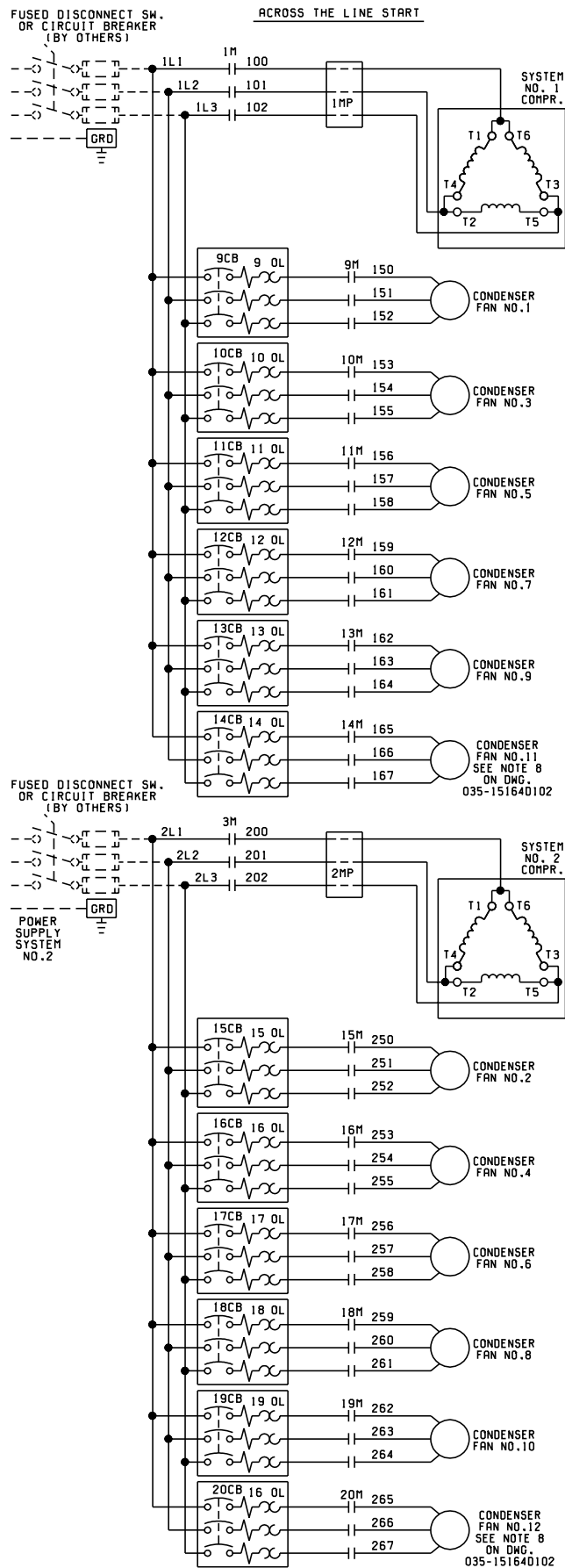

WIRING DIAGRAM WYE-DELTA START

NOTES:

1. Field wiring to be in accordance with the current edition of the National Electrical Code as well as all other applicable codes and specifications.
2. Numbers along the right side of a diagram are line identification numbers. The numbers at each line indicate the line number location of relay contacts. An unlined contact location signifies a normally closed contact. Numbers adjacent to circuit lines are the circuit identification numbers.
3. Any customer supplied contacts must be suitable for switching 24VDC. (Gold contacts recommended.) Control Wiring must not be in the same conduit with any line voltage wiring.
4. To cycle unit on and off automatically with contact shown, install a cycling device in series with the flow switch (FSLW). See Note 3 for contact rating and wiring specifications. Also refer to cautions on the following page.
5. To stop unit (Emergency Stop) with contacts other than those shown, install the stop contact between 5 and 1. If a stop device is not installed, a jumper must be connected between terminals 5 and 1. Device must have a minimum contact rating of 100VA at 115 volts A.C.
6. Alarm contacts are for annunciating alarm/unit malfunction. Contacts are rated at 115V, 100VA, resistive load only, and must be suppressed at load by user.
7. See Installation, Operation and Maintenance Manual when optional equipment is used.
8. Control panel to be securely connected to earth ground.
9. Us 2KVA transformer in optional transformer kit unless there are optional oil separator sump heaters which necessitates using a 3KVA transformer.

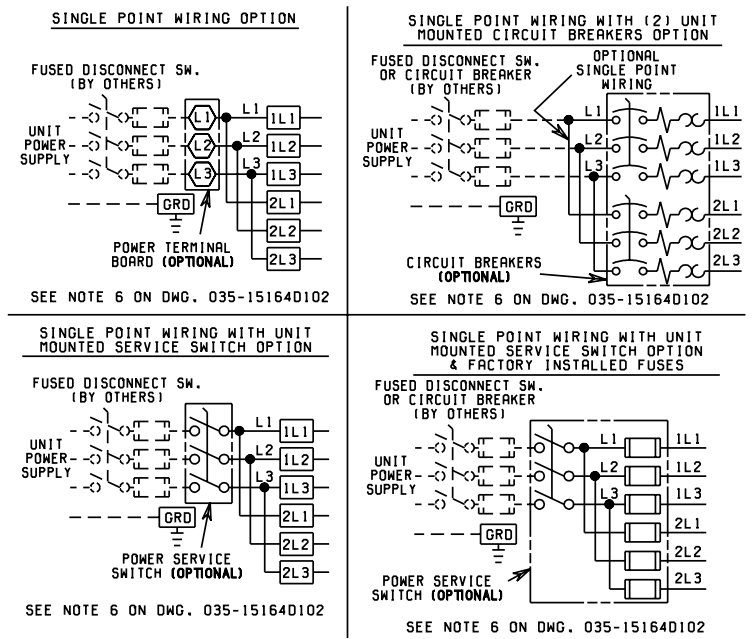

LD03226

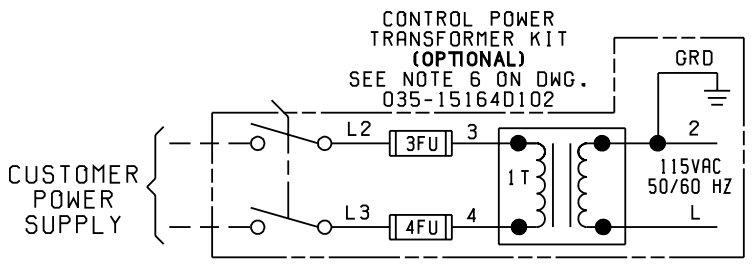

LD03227

LEGEND

- T S** Transient Voltage Suppression
- Terminal Block for Customer Connections
- Terminal Block for Customer Low Voltage (Class 2) Connections. See Note 2
- Terminal Block for YORK Connections Only
- Wiring and Components by YORK
- Optional Equipment
- Wiring and/or Components by Others

FIG. 7 – ELEMENTARY DIAGRAM – WYE-DELTA START

WIRING DIAGRAM WYE-DELTA START

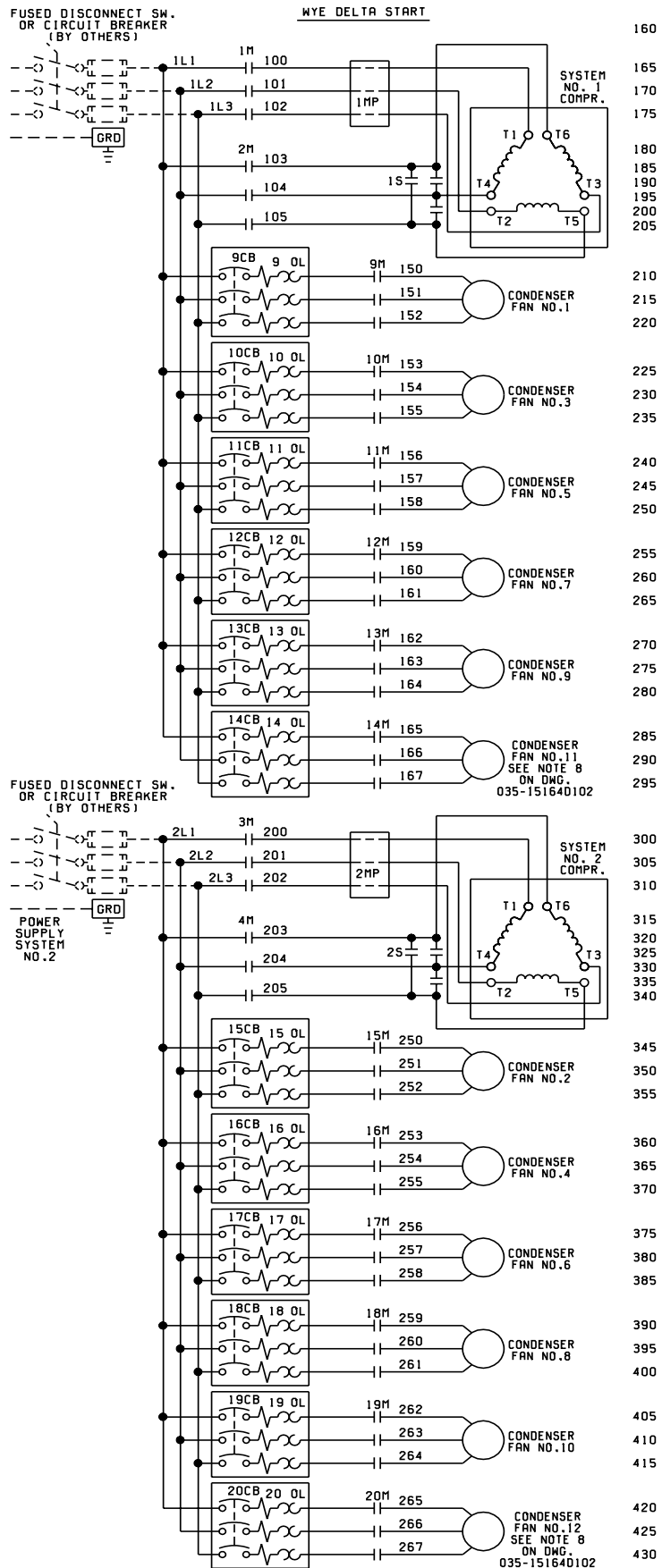

LD03229

ELEMENTARY DIAGRAM

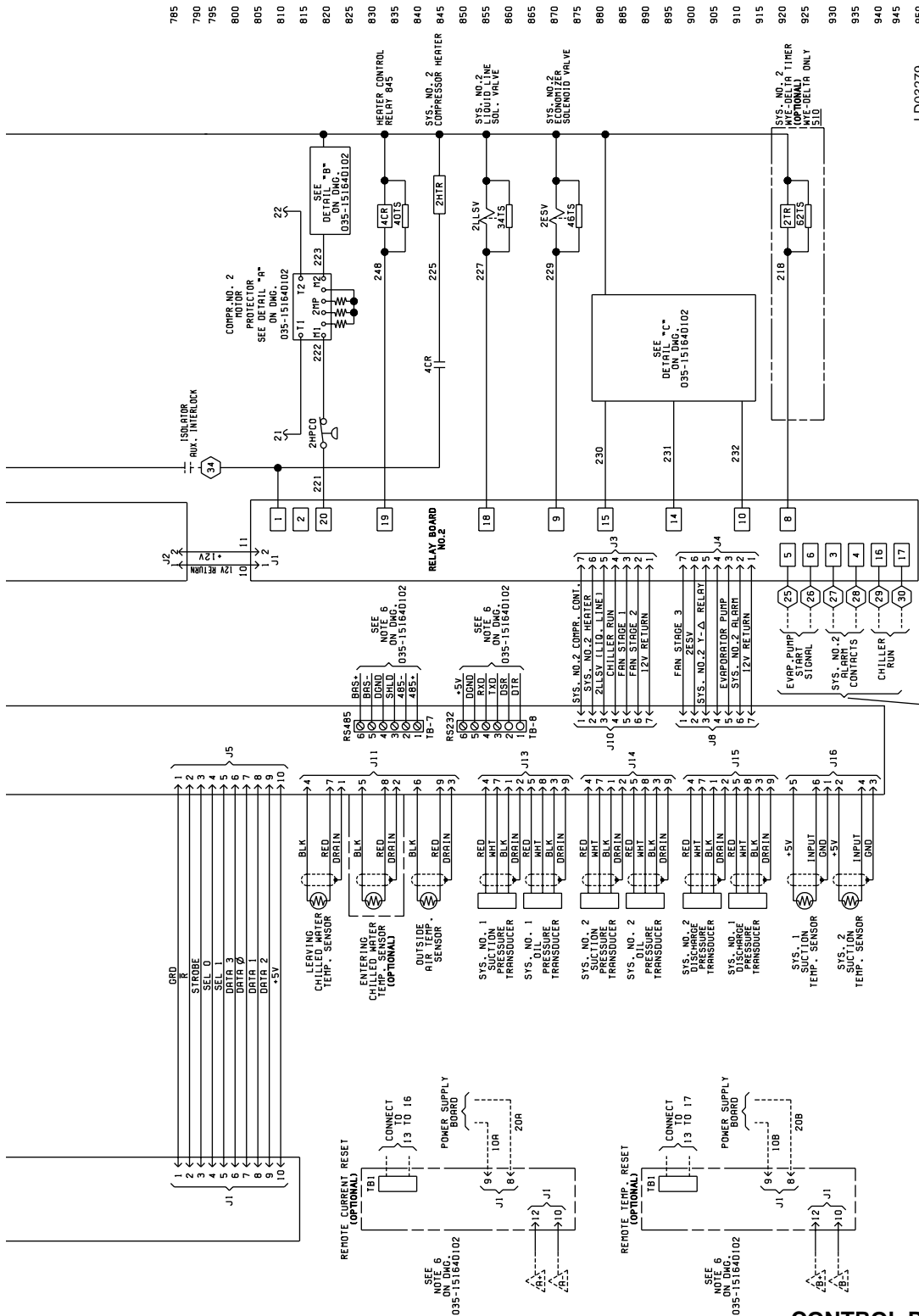

LD03279

CAUTION:
No Controls (relays, etc.) should be mounted in the Smart Panel enclosure or connected to power supplies in the control panel. Additionally, control wiring not connected to the Smart Panel should not be run through the cabinet. This could result in nuisance faults.

CAUTION:
Any inductive devices (relays) wired in series with the flow switch inputs or BAS inputs on terminals 13 - 19 or TB3, or any other terminals, must be suppressed with a YORK P/N 031-00808-000 suppressor across the relay/contact coil.

Any contacts connected to flow switch inputs or BAS inputs on terminals 13 - 19 or TB3, or any other terminals, must be suppressed with a YORK P/N 031-00808-000 suppressor across the relay/contact coil.

CAUTION:
Control wiring connected to the control panel should never be run in the same conduit with power wiring.

SEE NOTE 5

CONTROL POWER SUPPLY

UNIT VOLTAGE	CONTROL POWER SUPPLY	MIN CIRCUIT AMP.	MAX DUAL ELEMENT FUSE SIZE	NON-FUSED DISC. SWITCH SIZE
ALL MODELS W/O TRANS.	115-1-50/60	20A	20A 250V	30A 240V
MODELS WITH TRANS.	-17 -28 -46 -58	15A 15A 8A 8A	15A 250V 15A 250V 8A 600V 8A 600V	30A 240V 30A 240V 30A 480V 30A 600V

* All primary and secondary wiring between transformer and control panel included.

ELECTRONIC PANEL
(FRONT INSIDE VIEW)

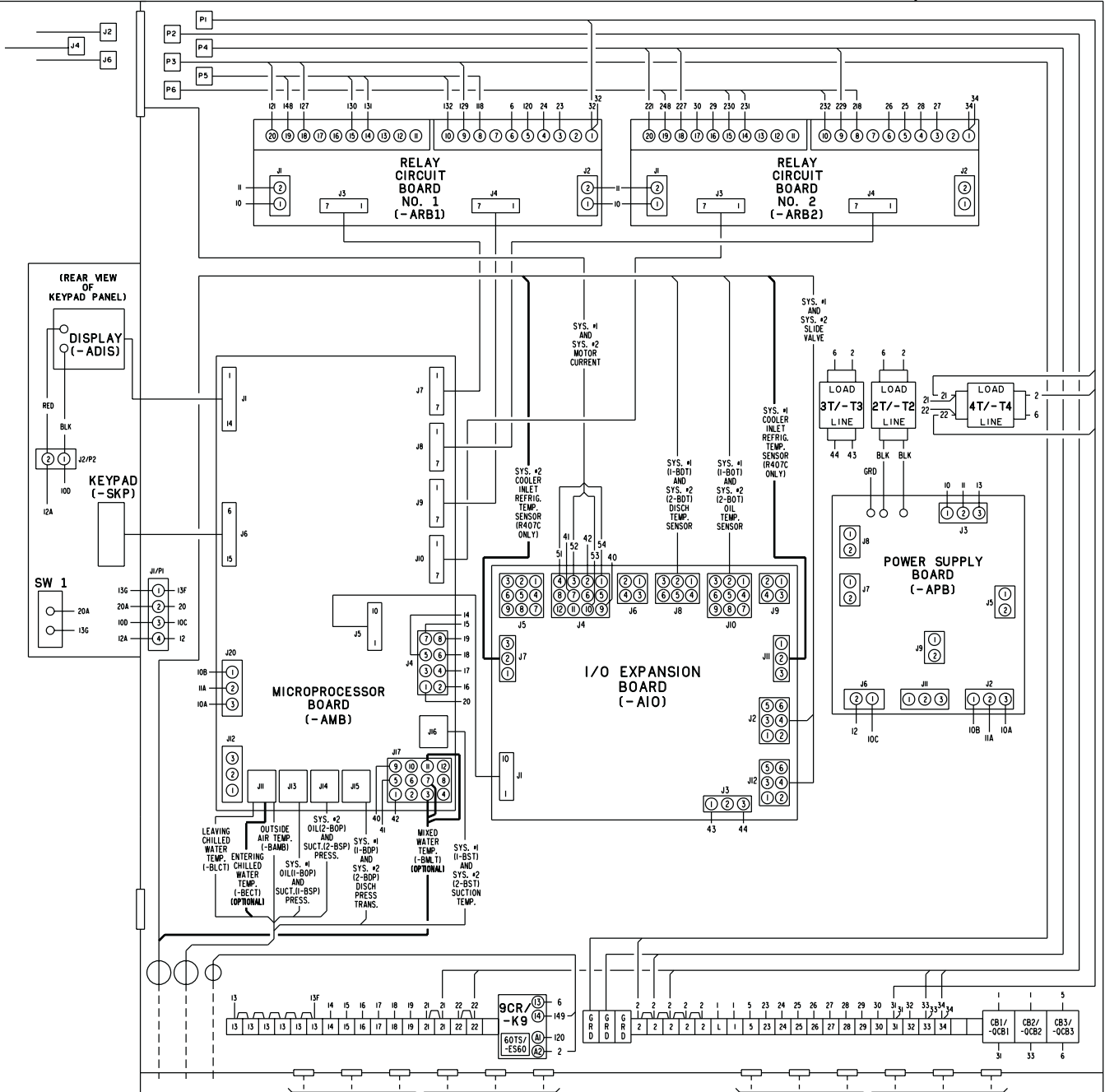

WIRING BY OTHERS
SEE ELEMENTARY DIAGRAM

WIRING BY OTHERS
SEE ELEMENTARY DIAGRAM

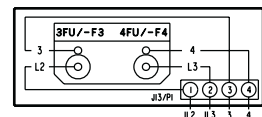
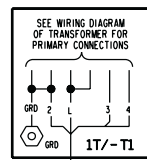

OPTIONAL PANEL
(FRONT INSIDE VIEW)

LEGEND

- | | | | | | |
|---|--|---|--------------------------------------|------------------------------|------------------------------------|
| 1CR THRU 4CR, 9CR/
-K1 THRU -K4, -K9 | -CONTROL RELAYS | 1M, 3M/
1-KLC OR 1-KALC, 2-KLC OR 2-KALC | -COMPRESSOR CONTACTORS | 2T, 3T, 4T/
-T2, -T3, -T4 | -MICRO PANEL TRANSFORMERS |
| CB1, CB2, CB3/
-QCB1, -QCB2, -QCB3 | -CIRCUIT BREAKERS | 2M, 4M/
1-KDC, 2-KDC | -COMPRESSOR CONTACTORS | 1TR, 2TR/
-K10, -K11 | -TIMER RELAYS |
| 9CB THRU 14CB | -OVERLOAD CIRCUIT BREAKERS (SYS. #1) | 1S, 2S/
1-KSC, 2-KSC | -COMPRESSOR CONTACTORS | TS/-ES | -TRANSIENT SUPPRESSORS |
| 15CB THRU 20CB | -OVERLOAD CIRCUIT BREAKERS (SYS. #2) | 9M THRU 14M/
-KF9 THRU -KF14 | -CONDENSER FAN CONTACTORS (SYS. #1) | PTB1, PTB2/
1-XTB, 2-XTB | -POWER TERMINAL BLOCK |
| 9 OL THRU 14 OL | -MOTOR OVERLOADS (SYS. #1) | 15M THRU 20M/
-KF15 THRU -KF20 | -CONDENSER FAN CONTACTORS (SYS. #2) | MCB1, MCB2/
1-QCB, 2-QCB | -MOTOR CIRCUIT BREAKER |
| 15 OL THRU 20 OL | -MOTOR OVERLOADS (SYS. #2) | 1MP/1-FMP | -MOTOR PROTECTOR (SYS. #1) | DSW1, DSW2/
1-QSD, 2-QSD | -DISCONNECT SERVICE SWITCH |
| -QFCB9 THRU -QFCB14 | -MOTOR OVERLOADS W/OVERLOAD CIRCUIT BREAKERS (SYS. #1) | 2MP/2-FMP | -MOTOR PROTECTOR (SYS. #2) | --- | -WIRING BY YORK |
| -QFCB15 THRU -QFCB20 | -MOTOR OVERLOADS W/OVERLOAD CIRCUIT BREAKERS (SYS. #2) | 1T/-T1 | -CONTROL TRANSFORMER 2KVA (OPTIONAL) | --- | -WIRING BY OTHERS |
| 3FU, 4FU/
-F3, -F4 | -TRANSFORMER FUSE (OPTIONAL) | | | --- | -OPTIONAL WIRING AND/OR COMPONENTS |

CONNECTION DIAGRAM, ELEC. BOX DXST DIRECT DRIVE

J1, J2, J3, J4, J5, J6, J7, J8, P7 & P8 — POWER PANEL

P1, P2, P3, P4, P5, & P6 — ELECTRONIC (MICRO) PANEL

NOTE: WIRE NUMBERS IDENTIFIED IN (PARENTHESIS) INDICATE THE ACTUAL HARNESS CODE STAMPED ON THE WIRE.

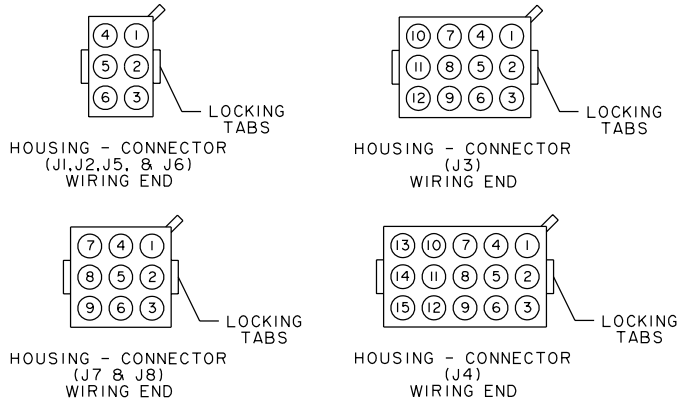



PLUG NO.	WIRE NO.	PLUG PIN NO.	PLUG NO.	WIRE NO.	PLUG PIN NO.	PLUG NO.	WIRE NO.	PLUG PIN NO.	PLUG NO.	WIRE NO.	PLUG PIN NO.
P1	21	1	P2	21	1	P3	2	1	P4	2	1
	2	2		2	2		GRD	2		GRD	2
	22	3		22	3		129	5		227	4
	31	4		33	4		127	6		229	5
	32	5		34	5		121	11		221	11
P5	130	1	P6	230	1	P7	125	1	P8	225	1
	131	2		231	2		2	2		2	2
	132	3		232	3		123	3		223	3
	148	4		248	4		140	4		240	4
	118	6		218	6		141	5		241	5
				142	6		142	6		242	6
				32	7		32	7		34	7
J1	21	1	J2	21	1	J3	2	1	J4	2	1
	2	2		2	2		GRD	2		GRD	2
	22	3		22	3		125	4		225	3
	3Y	4		3Y	4		129	5		229	4
	3X	5		3X	5		127	6		229	5
				121	11		121	11		221	11
				122	12		122	12		122	12
J5	30	1	J6	30	1	J7	25	1	J8	25	1
	31	2		31	2		2	2		2	2
	32	3		32	3		23	3		23	3
	48	4		48	4		40	4		40	4
	18	6		18	6		41	5		41	5
				42	6		42	6		42	6
				18	6		3X	7		3X	7

NOTES:

1. FIELD WIRING TO BE IN ACCORDANCE WITH THE CURRENT EDITION OF THE NATIONAL ELECTRICAL CODE AS WELL AS ALL OTHER APPLICABLE CODES AND SPECIFICATIONS.
2. CONTACTS MUST BE SUITABLE FOR SWITCHING 24VDC. (GOLD CONTACTS RECOMMENDED). WIRING SHALL NOT BE RUN IN THE SAME CONDUIT WITH ANY LINE VOLTAGE (CLASS 1) WIRING.
3. TO CYCLE UNIT ON AND OFF AUTOMATICALLY WITH CONTACT SHOWN, INSTALL A CYCLING DEVICE IN SERIES WITH THE FLOW SWITCH. SEE NOTE 2 FOR CONTACT RATING AND WIRING SPECIFICATIONS.
4. TO STOP UNIT (EMERGENCY STOP) WITH CONTACTS OTHER THAN THOSE SHOWN, INSTALL THE STOP CONTACT BETWEEN TERMINALS 5 AND 1. IF A STOP DEVICE IS NOT INSTALLED, A JUMPER MUST BE CONNECTED BETWEEN TERMINALS 5 AND 1. DEVICE MUST HAVE A MINIMUM CONTACT RATING OF 6A AT 115VOLTS A.C.
5. CONTACTS ARE RATED AT 115V, 100VA, RESISTIVE LOAD ONLY, AND MUST BE SUPPRESSED AT LOAD BY USER.
6. SEE INSTALLATION, OPERATION AND MAINTENANCE MANUAL WHEN OPTIONAL EQUIPMENT IS USED.

LD03282

LEGEND

- TS TRANSIENT VOLTAGE SUPPRESSION
-  TERMINAL BLOCK FOR CUSTOMER CONNECTIONS
-  TERMINAL BLOCK FOR CUSTOMER LOW VOLTAGE (CLASS 2) CONNECTIONS. SEE NOTE 2.
-  TERMINAL BLOCK FOR YORK CONNECTIONS ONLY
- WIRING AND COMPONENTS BY YORK
- OPTIONAL EQUIPMENT
- - - - - WIRING AND/OR COMPONENTS BY OTHERS

LD03283

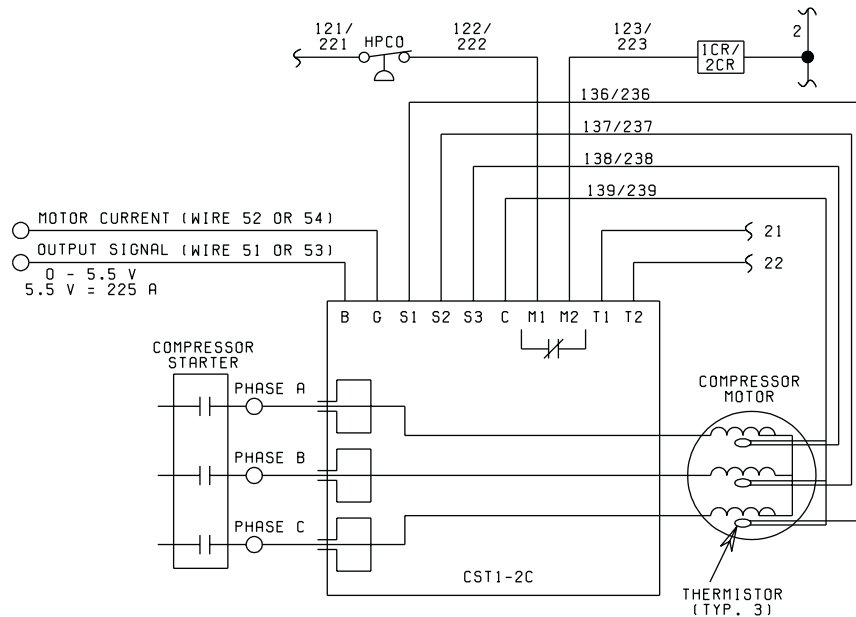

DETAIL "A"

LD03284

CONNECTION DIAGRAM (SYSTEM WIRING)

CONNECTION DIAGRAM SYSTEM WIRING
YCAS 295-605
(STYLE F)

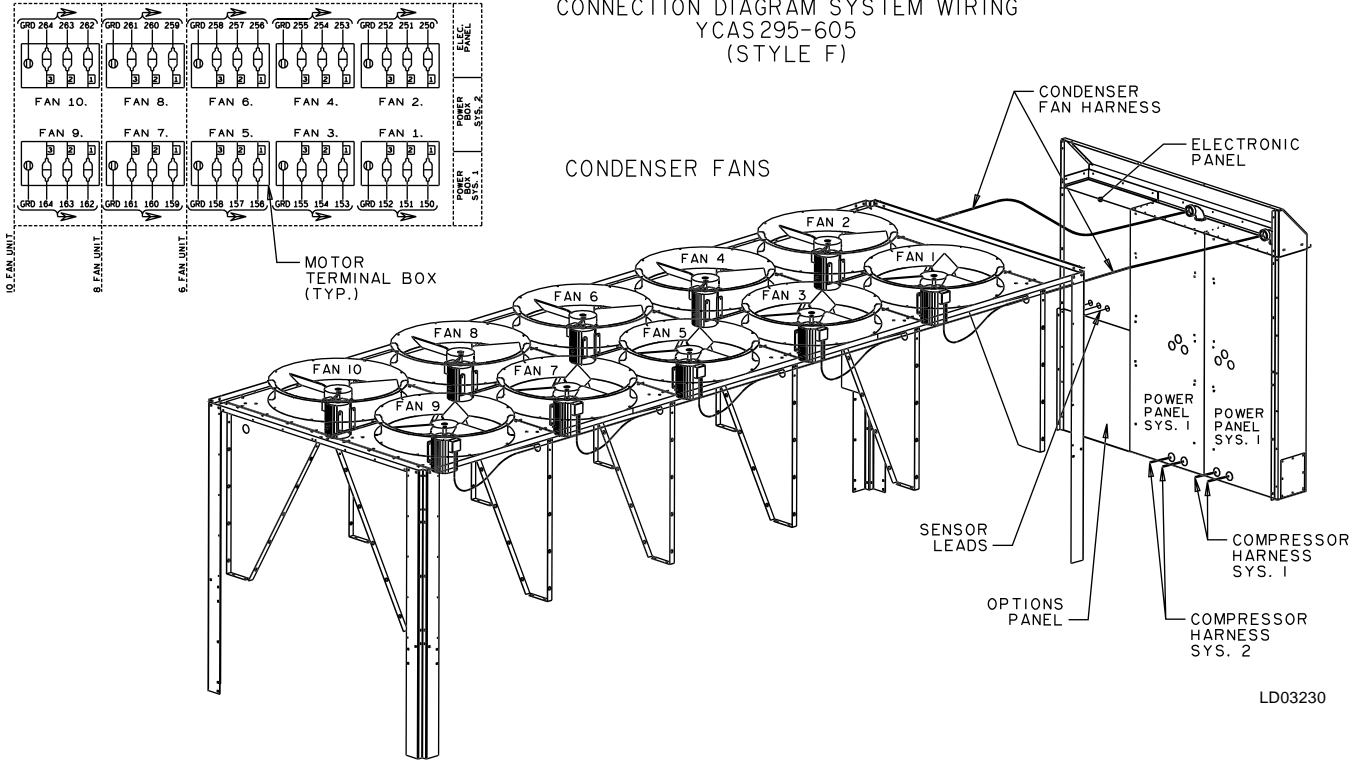

LD03230

LEGEND

- 1 HPCO SYS. No.1 HIGH PRESS. CUTOUT
- 2 HPCO SYS. No.2 HIGH PRESS. CUTOUT
- 1 HTR SYS. No.1 COMPR. CRANKCASE HEATER
- 2 HTR SYS. No.2 COMPR. CRANKCASE HEATER
- 3 HTR COOLER HEATER
- 1 LLSV SYS. No.1 LIQUID LINE SOLENOID VALVE (UNIT IDENT)
- 2 LLSV SYS. No.2 LIQUID LINE SOLENOID VALVE (UNIT IDENT)
- 1 ESV ECONOMIZER SOLENOID VALVE (UNIT IDENT)
- 2 ESV ECONOMIZER SOLENOID VALVE (UNIT IDENT)
- TXV 1 SYS. No.1 THERMAL EXPANSION VALVE (UNIT IDENT)
- TXV 2 SYS. No.2 THERMAL EXPANSION VALVE (UNIT IDENT)

COOLER

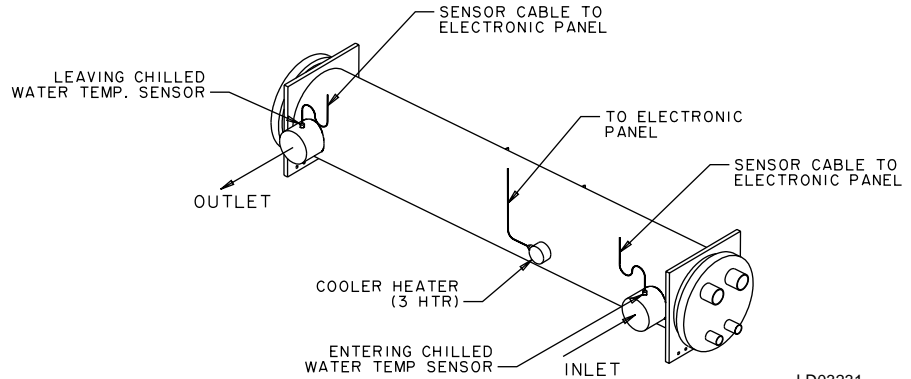

LD03231

COMPRESSORS (SYSTEMS 1 & 2)

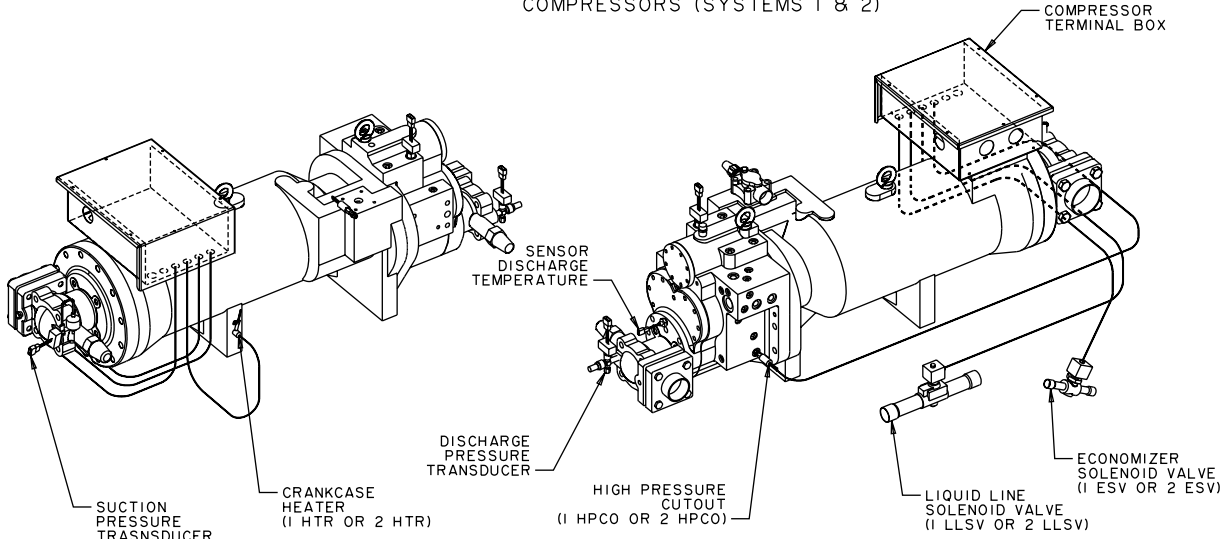

LD03232

COMPRESSOR TERMINAL BOX

SYSTEM I & 2 WYE-DELTA-START
2 & 4 POWER HARNESS UNITS

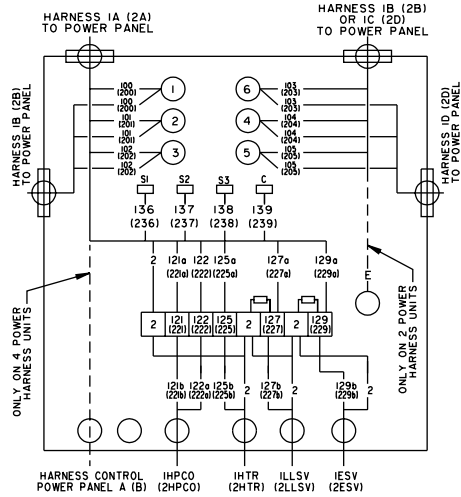

SYSTEM I & 2 ACROSS THE LINE
1 POWER HARNESS UNITS

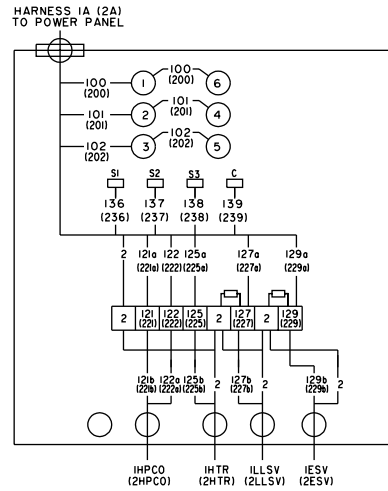

SYSTEM I & 2 ACROSS THE LINE
2 POWER HARNESS UNITS

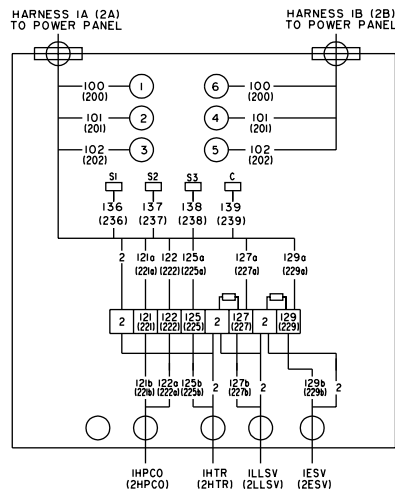

SYSTEM I & 2 ACROSS THE LINE
4 POWER HARNESS UNITS

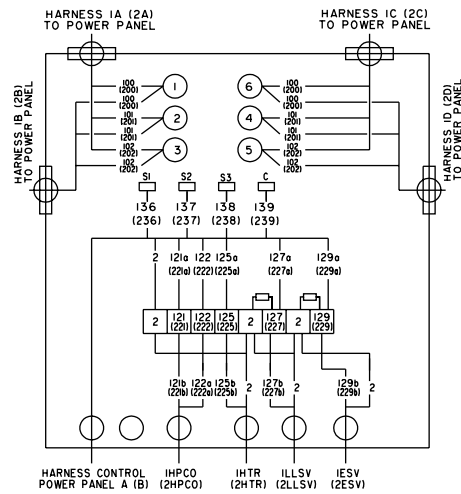

LD03233

