



**MILLENNIUM AIR-COOLED SCREW
LIQUID CHILLERS MODELS YCAS
STYLE F 60 Hz**

WIRING DIAGRAM

New Release

Form 201.18-W5 (200)

**MODELS YCAS0090 THROUGH YCAS0130
60 Hz Style F**



WARNING
HIGH VOLTAGE

is used in the operation of this equipment
DEATH OR SERIOUS INJURY
may result if personnel fail to observe precautions

Work on electrical equipment should not be undertaken unless individual(s) has (have) been trained in the proper maintenance of the equipment and is (are) familiar with its potential hazards.

Shut off power supply to equipment before beginning work and follow lockout procedures. When working inside equipment with power off, take special care to discharge every capacitor likely to hold a dangerous potential.

Be careful not to contact high voltage connections when installing or operating the equipment.

LOW VOLTAGE

Do not be misled by the term "low voltage". Voltages as low as 50 volts may cause death.

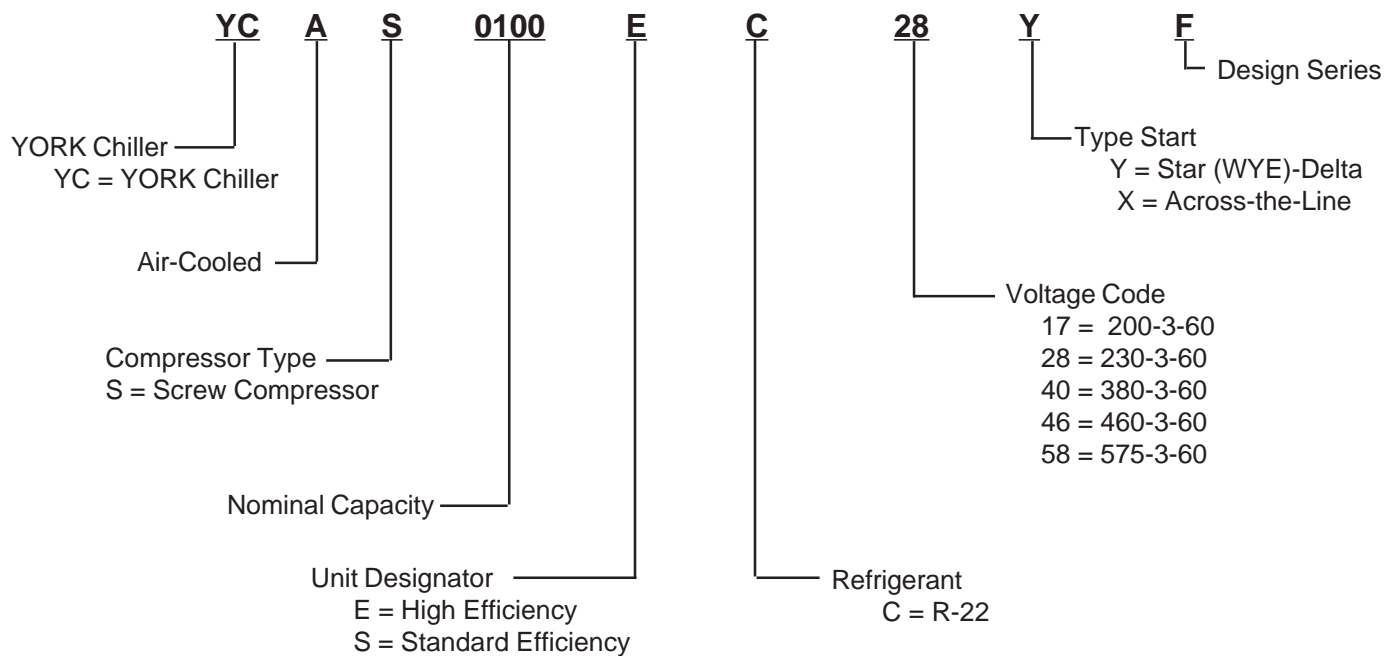

MULTIPLE POINT POWER SUPPLY CONNECTION

Each of the Two Field Provided Power Supply Circuits Individually protected with Branch Circuit Protection. Field Connections to Factory provided Terminal Block [Std], disconnects [Opt], or Individual System Breakers [Opt] in each of the tow Motor Control Centers.)

Chiller Model YCAS	VOLTS	SYSTEM #1 FIELD-SUPPLIED WIRING												
		FIELD PROVIDED POWER SUPPLY				FACTORY PROVIDED (LUGS) WIRE RANGE ⁷			COMPRESSOR			FANS ^{11, 12}		
		MCA ¹	MIN NF DISC SW ^{2, 9}	OVER-CURRENT PROTECTION ¹³		STD. TERM. BLOCK	OPTIONAL NF DISC. SWITCH	OPT. C.B.	RLA	Y-LRA	X-LRA	Qty	FLA (ea)	LRA (ea)
				MIN. ^{3,5}	MAX. ^{4,6}									
0090EC	200	224	250	300	350	#2 - 300	#6 - 350	250 - 500	159	404	1257	3	8.2	38
	230	196	200	250	300	#2 - 300	#14 - 250	#14 - 250	138	354	1103	3	7.8	33
	380	120	150	150	200	#2 - 4/0	#14 - 250	#14 - 250	84	219	681	3	4.8	23
	460	100	100	125	150	#6 - 1/0	#14 - 250	#14 - 250	70	174	542	3	4.0	19
	575	79	100	100	125	#18 - #2	#14 - 250	#14 - 250	55	138	431	3	3.1	15
0100EC	200	235	250	300	400	1/0 - 500	#14 - 250	250 - 500	168	404	1257	3	8.2	38
	230	206	200	250	350	#2 - 300	#6 - 350	250 - 500	146	354	1103	3	7.8	33
	380	125	150	150	200	#2 - 4/0	#14 - 250	#14 - 250	88	219	681	3	4.8	23
	460	104	100	125	175	#6 - 1/0	#14 - 250	#14 - 250	73	174	542	3	4.0	19
	575	82	100	100	125	#18 - #2	#14 - 250	#14 - 250	58	138	431	3	3.1	15
0110EC	200	321	400	400	500	1/0 - 500	250 - 500	250 - 500	228	591	1866	3	12.0	52
	230	279	400	350	450	1/0 - 500	250 - 500	250 - 500	199	481	1518	3	10.0	62
	380	167	200	200	250	#2 - 4/0	#14 - 250	#14 - 250	121	285	900	3	5.2	21
	460	139	150	175	225	#2 - 4/0	#14 - 250	#14 - 250	99	228	719	3	5.0	27
	575	113	150	150	175	#2 - 4/0	#14 - 250	#14 - 250	81	182	574	3	3.9	26
0120EC	200	345	400	450	500	1/0 - 500	(2) 3/0 - 250	(3) 2/0 - 400	247	591	1866	3	12.0	52
	230	299	400	400	500	1/0 - 500	250 - 500	250 - 500	215	481	1518	3	10.0	62
	380	179	200	225	300	#2 - 4/0	#14 - 250	#14 - 250	130	285	900	3	5.2	21
	460	149	150	200	250	#2 - 4/0	#14 - 250	#14 - 250	107	228	719	3	5.0	27
	575	121	150	150	200	#2 - 4/0	#14 - 250	#14 - 250	87	182	574	3	3.9	26

See page 11 for Electrical Notes

Chiller Model YCAS	VOLTS	SYSTEM #2 FIELD-SUPPLIED WIRING												
		FIELD PROVIDED POWER SUPPLY				FACTORY PROVIDED (LUGS) WIRE RANGE ⁷			COMPRESSOR			FANS ^{11, 12}		
		MCA ¹	MIN NF DISC SW ^{2, 9}	OVER-CURRENT PROTECTION ¹³		STD. TERM. BLOCK	OPTIONAL NF DISC. SWITCH	OPT. C.B.	RLA	Y-LRA	X-LRA	Qty	FLA (ea)	LRA (ea)
				MIN. ^{3,5}	MAX. ^{4,6}									
0090EC	200	224	250	300	350	#2 - 300	#6 - 350	250 - 500	159	404	1257	3	8.2	38
	230	196	200	250	300	#2 - 300	#14 - 250	#14 - 250	138	354	1103	3	7.8	33
	380	120	150	150	200	#2 - 4/0	#14 - 250	#14 - 250	84	219	681	3	4.8	23
	460	100	100	125	150	#6 - 1/0	#14 - 250	#14 - 250	70	174	542	3	4.0	19
	575	79	100	100	125	#18 - #2	#14 - 250	#14 - 250	55	138	431	3	3.1	15
0100EC	200	235	250	300	400	1/0 - 500	#14 - 250	250 - 500	168	404	1257	3	8.2	38
	230	206	200	250	350	#2 - 300	#6 - 350	250 - 500	146	354	1103	3	7.8	33
	380	125	150	150	200	#2 - 4/0	#14 - 250	#14 - 250	88	219	681	3	4.8	23
	460	104	100	125	175	#6 - 1/0	#14 - 250	#14 - 250	73	174	542	3	4.0	19
	575	82	100	100	125	#18 - #2	#14 - 250	#14 - 250	58	138	431	3	3.1	15
0110EC	200	241	250	300	400	1/0 - 500	#6 - 350	250 - 500	164	404	1257	3	12.0	52
	230	209	200	250	350	#2 - 300	#14 - 250	250 - 500	143	354	1103	3	10.0	62
	380	124	150	150	200	#2 - 4/0	#14 - 250	#14 - 250	86	219	681	3	5.2	21
	460	104	100	125	150	#6 - 1/0	#14 - 250	#14 - 250	71	174	542	3	5.0	27
	575	82	100	100	125	#18 - #2	#14 - 250	#14 - 250	56	138	431	3	3.9	26
0120EC	200	241	250	300	400	1/0 - 500	#6 - 350	250 - 500	164	404	1257	3	12.0	52
	230	209	200	250	350	#2 - 300	#14 - 250	250 - 500	143	354	1103	3	10.0	62
	380	124	150	150	200	#6 - 1/0	#14 - 250	#14 - 250	86	219	681	3	5.2	21
	460	104	100	125	150	#2 - 4/0	#14 - 250	#14 - 250	71	174	542	3	5.0	27
	575	82	100	100	125	#18 - #2	#14 - 250	#14 - 250	56	138	431	3	3.9	26

OPTIONAL SINGLE POINT POWER SUPPLY CONNECTION AND INDIVIDUAL UNIT CIRCUIT BREAKERS

One Field Provided Power Supply Circuit to the chiller. Field connections to Power Terminal Block or Non-Fused Disconnect in 'Option Panel'. Individual Branch Circuit Protection (Breakers) per Motor Control Center ¹⁰

Chiller Model YCAS	VOLTS	FIELD SUPPLIED WIRING					
		FIELD PROVIDED POWER SUPPLY			FACTORY PROVIDED (LUGS) WIRE RANGE ⁷		
		MCA ¹	MIN NF DISC SW ^{2,9}	OVER-CURRENT PROTECTION ¹³			
				MIN. ^{3,5}	MAX. ^{4,6}	STD. TERM. BLOCK	OPTIONAL NF DISC. SWITCH
0090EC	200	407	600	450	500	#2 - 300	(3) 2/0 - 400
	230	358	400	400	450	1/0 - 500	2/0-500
	380	218	250	250	300	#2 - 300	#2-300
	460	182	200	200	250	#2 - 4/0	#14 - 250
	575	143	150	175	175	#2 - 4/0	#14 - 250
0100EC	200	428	600	500	500	#2 - 300	(3) 2/0 - 400
	230	376	400	450	500	1/0 - 500	(3) 2/0 - 400
	380	227	250	250	300	#2 - 300	250 - 500
	460	189	200	225	250	#2 - 4/0	#14 - 250
	575	150	200	175	200	#2 - 4/0	#14 - 250
0110EC	200	521	600	600	700	1/0 - 500	(3) 2/0 - 400
	230	452	600	600	600	#2 - 300	(3) 2/0 - 400
	380	269	400	300	350	1/0 - 500	250 - 500
	460	225	250	250	300	#2 - 300	#14 - 250
	575	181	200	225	250	#2 - 4/0	#14 - 250
0120EC	200	545	600	700	700	1/0 - 500	(2) 250 - 500
	230	472	600	600	600	#2 - 300	(3) 2/0 - 400
	380	280	400	350	400	1/0 - 500	250 - 500
	460	235	250	300	300	#2 - 300	250 - 500
	575	189	200	225	250	#2 - 4/0	#14 - 250

See page 11 for Electrical Notes

Chiller Model YCAS	VOLTS	SYSTEM #1						SYSTEM #2					
		COMPRESSOR			FANS ^{11, 12}			COMPRESSOR			FANS ^{11, 12}		
		RLA	Y-LRA	X-LRA	Qty	FLA (ea)	LRA (ea)	RLA	Y-LRA	X-LRA	Qty	FLA (ea)	LRA (ea)
0090EC	200	159	404	1257	3	8.2	38.0	159	404	1257	3	8.2	38.0
	230	138	354	1103	3	7.8	33.0	138	354	1103	3	7.8	33.0
	380	84	219	681	3	4.8	23.0	84	219	681	3	4.8	23.0
	460	70	174	542	3	4.0	19.0	70	174	542	3	4.0	19.0
	575	55	138	431	3	3.1	15.2	55	138	431	3	3.1	15.2
0100EC	200	168	404	1257	3	8.2	38.0	168	404	1257	3	8.2	38.0
	230	146	354	1103	3	7.8	33.0	146	354	1103	3	7.8	33.0
	380	88	219	681	3	4.8	23.0	88	219	681	3	4.8	23.0
	460	73	174	542	3	4.0	19.0	73	174	542	3	4.0	19.0
	575	58	138	431	3	3.1	15.2	58	138	431	3	3.1	15.2
0110EC	200	228	591	1866	3	12.0	52.0	164	404	1257	3	12.0	52.0
	230	199	481	1518	3	10.0	62.0	143	354	1103	3	10.0	62.0
	380	121	285	900	3	5.2	21.0	86	219	681	3	5.2	21.0
	460	99	228	719	3	5.0	27.0	71	174	542	3	5.0	27.0
	575	81	182	574	3	3.9	26.0	56	138	431	3	3.9	26.0
0120EC	200	247	591	1866	3	12.0	52.0	164	404	1257	3	12.0	52.0
	230	215	481	1518	3	10.0	62.0	143	354	1103	3	10.0	62.0
	380	130	285	900	3	5.2	21.0	86	219	681	3	5.2	21.0
	460	107	228	719	3	5.0	27.0	71	174	542	3	5.0	27.0
	575	87	182	574	3	3.9	26.0	56	138	431	3	3.9	26.0

OPTIONAL SINGLE POINT POWER SUPPLY CONNECTION

(One Field Provided Power Supply Circuit to the chiller. Field Connection to Power Terminal Block or Non-Fused Disconnect in 'Option Panel'.

No internal Branch Circuit Protection per Motor Control Center¹⁰.)

Chiller Model YCAS	FIELD SUPPLIED WIRING						
	VOLTS	FIELD PROVIDED POWER SUPPLY				FACTORY PROVIDED (LUGS) WIRE RANGE ⁷	
		MCA ¹	MIN NF DISC SW ^{2, 9}	OVER-CURRENT PROTECTION ¹³			
				MIN. ^{3, 5}	MAX. ^{4, 6}	STD. TERM. BLOCK	OPTIONAL NF DISC. SWITCH
0090EC	380	218	250	250	300	#2 - 300	#2-300
	460	182	200	200	250	#2 - 4/0	#14 - 250
	575	143	150	175	175	#2 - 4/0	#14 - 250
0100EC	380	227	250	250	300	#2 - 300	250 - 500
	460	189	200	225	250	#2 - 4/0	#14 - 250
	575	150	200	175	200	#2 - 4/0	#14 - 250
0110EC	380	269	400	300	350	1/0 - 500	250 - 500
	460	225	250	250	300	#2 - 300	#14 - 250
	575	181	200	225	250	#2 - 4/0	#14 - 250
0120EC	380	280	400	350	400	1/0 - 500	250 - 500
	460	235	250	300	300	#2 - 300	250 - 500
	575	189	200	225	250	#2 - 4/0	#14 - 250

See page 11 for Electrical Notes

Chiller Model YCAS	VOLTS	SYSTEM #1					SYSTEM #2				
		COMPRESSOR		FANS ^{11, 12}			COMPRESSOR		FANS ^{11, 12}		
		RLA	X-LRA	Qty	FLA (ea)	LRA (ea)	RLA	X-LRA	Qty	FLA (ea)	LRA (ea)
0090EC	380	84	681	3	4.8	23.0	84	681	3	4.8	23.0
	460	70	542	3	4.0	19.0	70	542	3	4.0	19.0
	575	55	431	3	3.1	15.2	55	431	3	3.1	15.2
0100EC	380	88	681	3	4.8	23.0	88	681	3	4.8	23.0
	460	73	542	3	4.0	19.0	73	542	3	4.0	19.0
	575	58	431	3	3.1	15.2	58	431	3	3.1	15.2
0110EC	380	121	900	3	5.2	21.0	86	681	3	5.2	21.0
	460	99	719	3	5.0	27.0	71	542	3	5.0	27.0
	575	81	574	3	3.9	26.0	56	431	3	3.9	26.0
0120EC	380	130	900	3	5.2	21.0	86	681	3	5.2	21.0
	460	107	719	3	5.0	27.0	71	542	3	5.0	27.0
	575	87	574	3	3.9	26.0	56	431	3	3.9	26.0

OPTIONAL SINGLE POINT POWER SUPPLY CONNECTION TO FACTORY CIRCUIT BREAKER

(One Field Provided Power Supply Circuit to the chiller. Field Connection to Power Terminal Block or Non-Fused Disconnect in 'Option Panel'.
No internal Branch Circuit Protection per Motor Control Center¹⁰.)

Chiller Model YCAS	Volts	Field Supplied Wiring			System #1					System #2				
		MCA ¹	Factory Supplied Breaker		Compressor		Fans ^{11, 12}			Compressor		Fans ^{11, 12}		
			Rating ^{5,6}	Wire Range ⁷ (Lugs)	RLA	X-LRA	Qty	FLA (ea)	LRA (ea)	RLA	X-LRA	Qty	FLA (ea)	LRA (ea)
0090EC	380	218	300	#N/A	84	681	3	4.8	23.0	84	681	3	4.8	23.0
	460	182	250	#14 - 250	70	542	3	4.0	19.0	70	542	3	4.0	19.0
	575	143	200	#14 - 250	55	431	3	3.1	15.2	55	431	3	3.1	15.2
0100EC	380	227	300	250 - 500	88	681	3	4.8	23.0	88	681	3	4.8	23.0
	460	189	250	#14 - 250	73	542	3	4.0	19.0	73	542	3	4.0	19.0
	575	150	200	#14 - 250	58	431	3	3.1	15.2	58	431	3	3.1	15.2
0110EC	380	269	350	250 - 500	121	900	3	5.2	21.0	86	681	3	5.2	21.0
	460	225	300	#14 - 250	99	719	3	5.0	27.0	71	542	3	5.0	27.0
	575	181	250	#14 - 250	81	574	3	3.9	26.0	56	431	3	3.9	26.0
0120EC	380	280	400	250 - 500	130	900	3	5.2	21.0	86	681	3	5.2	21.0
	460	235	300	250 - 500	107	719	3	5.0	27.0	71	542	3	5.0	27.0
	575	189	250	#14 - 250	87	574	3	3.9	26.0	56	431	3	3.9	26.0

See page 11 for Electrical Notes

CONTROL POWER SUPPLY (UNITS WITHOUT STANDARD CONTROL CIRCUIT TRANSFORMER)

NO. OF COMPRESSORS	CONTOL POWER SUPPLY	MCA (MAX LOAD CURRENT)	MAX DUAL ELEMENT FUSE SIZE	NON-FUSED DISCONNECT SWITCH SIZE
2	115V-Ø	20A	20A	30A
3 or 4 (Non-CE 50/60Hz)	115V-Ø	30A	30A	30A
3 or 4 (CE 50Hz)	115V-Ø	25A	30A	30A

LEGEND

ACR-LINE	ACROSS-THE-LINE START
C.B.	CIRCUIT BREAKER
D.E.	DUAL ELEMENT FUSE
DISC SW	DISCONNECT SWITCH
FACT CB	FACTORY-MOUNTED CIRCUIT BREAKER
FLA	FULL LOAD AMPS
HZ	HERTZ
MAX	MAXIMUM
MCA	MINIMUM CIRCUIT AMPACITY
MIN	MINIMUM
MIN NF	MINIMUM NON-FUSED
RLA	RUNNING LOAD AMPS
S.P. WIRE	SINGLE-POINT WIRING
Y- Δ	WYE-DELTA START
X-LRA	ACROSS-THE -LINE INRUSH LOCKED ROTOR AMPS
Y-LRA	WYE-DELTA INRUSH LOCKED ROTOR AMPS

- Minimum circuit ampacity (MCA) is based on 125% of the rated load amps for the largest motor plus 100% of the rated load amps for all other loads included in the circuit, per N.E.C. Article 430-24. If a Factory Mounted Control Transformer is provided, add the following to the system #1 MCA values in the YCAS Tables: -17, add 10A; -28, add 9A; -40, add 5A; -46, add 4A; -58, add 3A.
- The recommended disconnect switch is based on a minimum of 115% of the summation rated load amps of all the loads included in the circuit, per N.E.C. 440 - 12A1.
- Minimum fuse size is based on 150% of the largest motor RLA plus 100% of the remaining RLAs (UL Standard **1995**, Section 36.1). Minimum fuse rating = $(1.5 \times \text{largest compressor RLA}) + \text{other compressor RLAs} + (\# \text{ fans} \times \text{each fan motor FLA})$.
- Maximum dual element fuse size is based on 225% maximum plus 100% of the rated load amps for all other loads included in the circuit, per N.E.C. 440-22. Maximum fuse rating = $(2.25 \times \text{largest compressor RLA}) + \text{other compressor RLAs} + (\# \text{ fans} \times \text{each fan motor FLA})$.
- Minimum circuit breaker is 150% maximum plus 100% of rated load amps included in the circuit, per circuit per UL **1995** Fig. 36.2. Minimum circuit breaker rating = $(1.5 \times \text{largest compressor RLA}) + \text{other compressor RLAs} + (\# \text{ fans} \times \text{each fan motor FLA})$.
- Maximum circuit breaker is based on 225% maximum plus 100% of the rated load amps for all loads included in the circuit, per circuit, per UL **1995** Fig. 36.2. Maximum circuit breaker rating = $(2.25 \times \text{largest compressor RLA}) + \text{other compressor RLAs} + (\# \text{ fans} \times \text{each fan motor FLA})$.
- The Incoming Wire Range is the minimum and maximum wire size that can be accommodated by unit wiring lugs. The (1), (2), or (3) indicate the number of termination points or lugs, which are available per phase. Actual wire size and number of wires per phase must be determined based on ampacity and job requirements using N.E.C. wire sizing information. The above recommendations are based on the National Electric Code and using **copper** connectors only. Field wiring must also comply with local codes.
- A ground lug is provided for each compressor system to accommodate field-grounding conductor per N.E.C. Article 250-54. A control circuit-grounding lug is also supplied. Incoming ground wire range is #6 - 350 MCM.
- The field supplied disconnect is a "Disconnecting Means" as defined in N.E.C. 100.B, and is intended for isolating the unit from the available power supply to perform maintenance and troubleshooting. This disconnect is not intended to be a Load Break Device.
- Two-compressor machines with single-point power connection, and equipped with Star-Delta compressor motor start must also include Factory provided circuit breakers in each motor control center. All 3 & 4 compressor machines equipped with Star-Delta compressor motor start must also include Factory provided circuit breakers in each motor control center.
- Consult factory for Electrical Data on units equipped with "High Static Fan" option. 60Hz High Static Fans are 3.8kW each, 50Hz 3.5kW each.
- FLA for each "Low Noise Fan" motor: 200v = 8.0A, 230v = 7.8A, 380v = 4.4A, 460v = 3.6A, 575v = 2.9A, 380v/50Hz = 4.1A.
- Group Rated breaker must be HACR type for cUL Machines.

WIRING DIAGRAM ACROSS-THE-LINE START

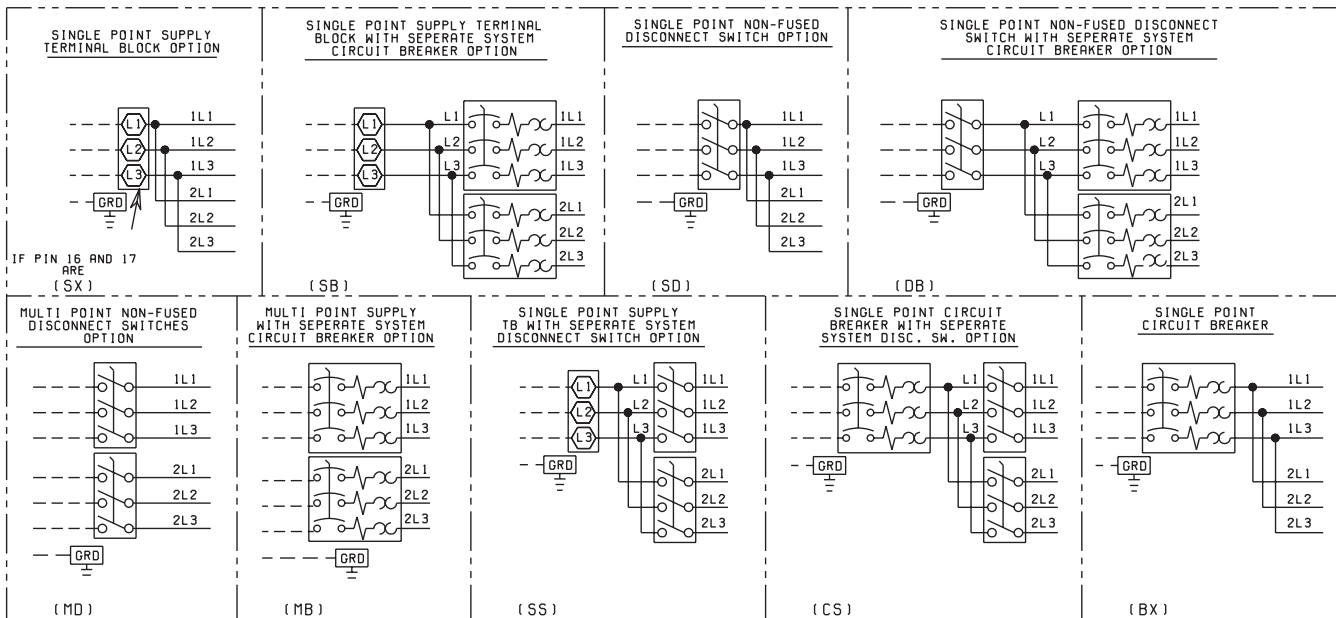

NOTES:

1. Field wiring to be in accordance with the current edition of the National Electrical Code as well as all other applicable codes and specifications.
2. Contacts must be suitable for switching 24VDC. (Gold contacts recommended). Wiring shall NOT run in the same conduit with any line voltage (Class I) wiring.
3. To cycle unit on and off automatically with contacts shown, install a cycling device in series with the flow switch. See note 2 for contact rating and wiring specifications.
4. To stop unit (emergency stop) with contacts other than those shown, install the stop contact between terminals 5 and 1. If a stop device is not installed, a jumper must be connected between terminals 5 and 1. Device must have a minimum contact rating of 6A at 115 Volts AC.
5. Contacts are rated at 115V, 100VA, resistive load only, and must be suppressed at load by user.
6. See Installation, Operation, and Maintenance manual when optional equipment is used.

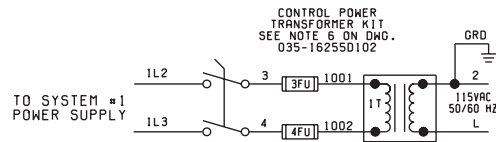

CONTROL POWER SUPPLY

UNIT VOLTAGE	CONTROL POWER SUPPLY	MIN. CIRCUIT AMP	MAX DUAL ELEMENT FUSE SIZE	NON FUSED DISC. FUSE SIZE
ALL MODELS W/O TRANS	115-1-50/60	20A	20A 250V	30A 240V
MODELS WITH TRANS. *	-17	200-1-60	15A 250V	30A 240V
	-28	230-1-60	15A 250V	30A 240V
	-46	400-1-60	8A 600V	30A 480V
	-58	575-1-60	8A 600V	30A 600V

FIG. 1 - ELEMENTARY DIAGRAM - ACROSS-THE-LINE START

WIRING DIAGRAM ACROSS-THE-LINE START

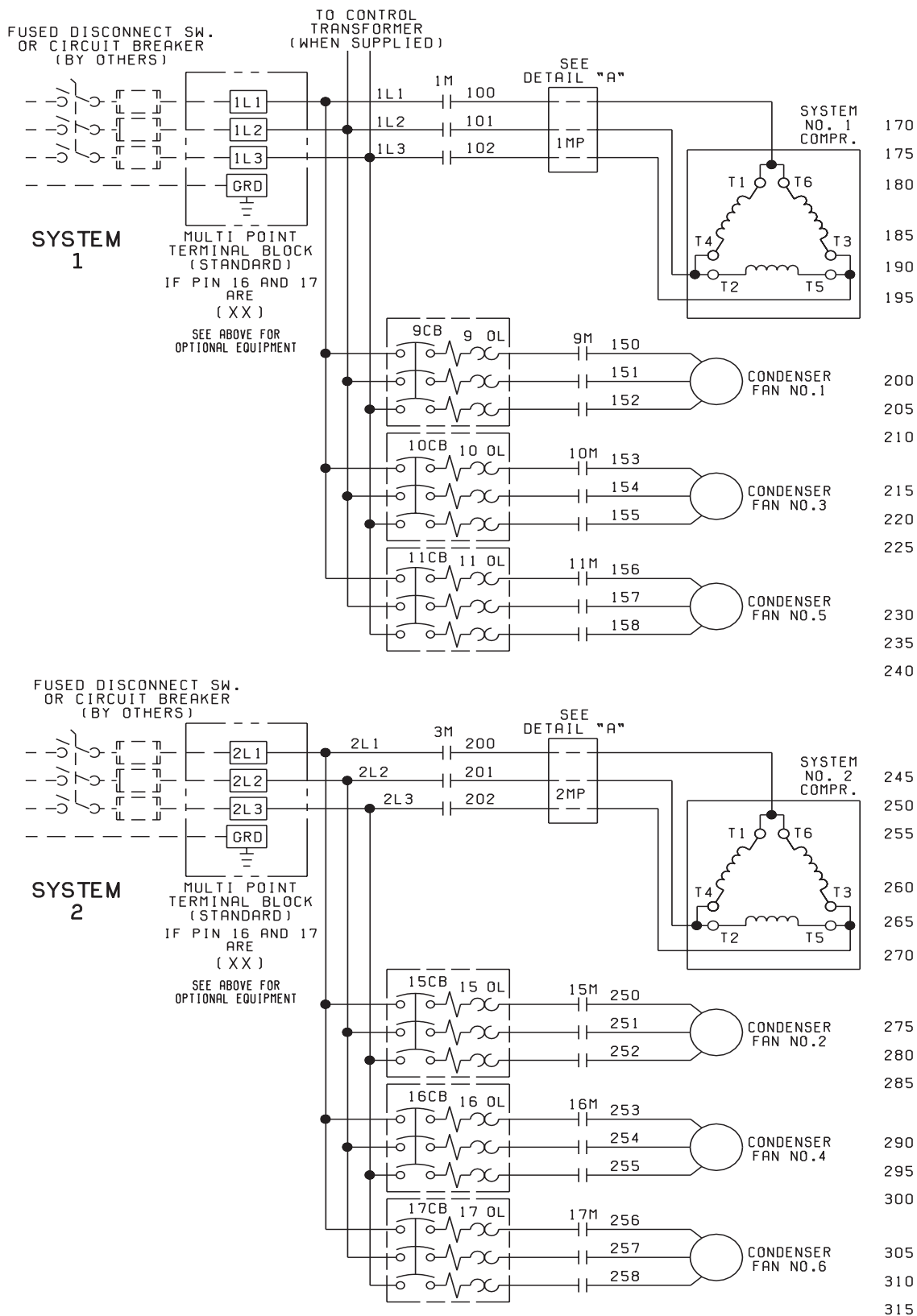

ELEMENTARY DIAGRAM
YCS (STYLE F)
STANDARD AND REMOTE EVAPORATOR UNITS

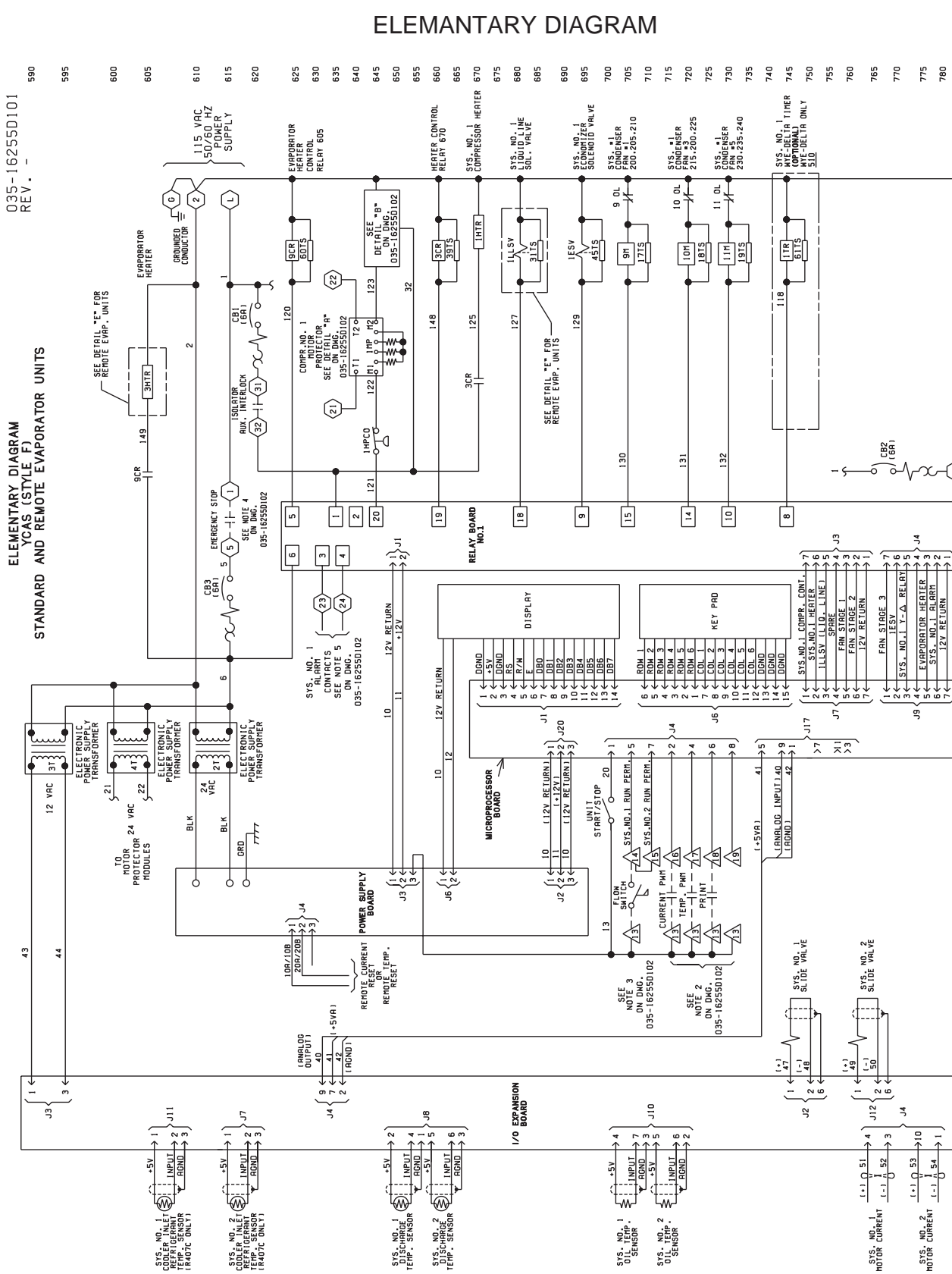
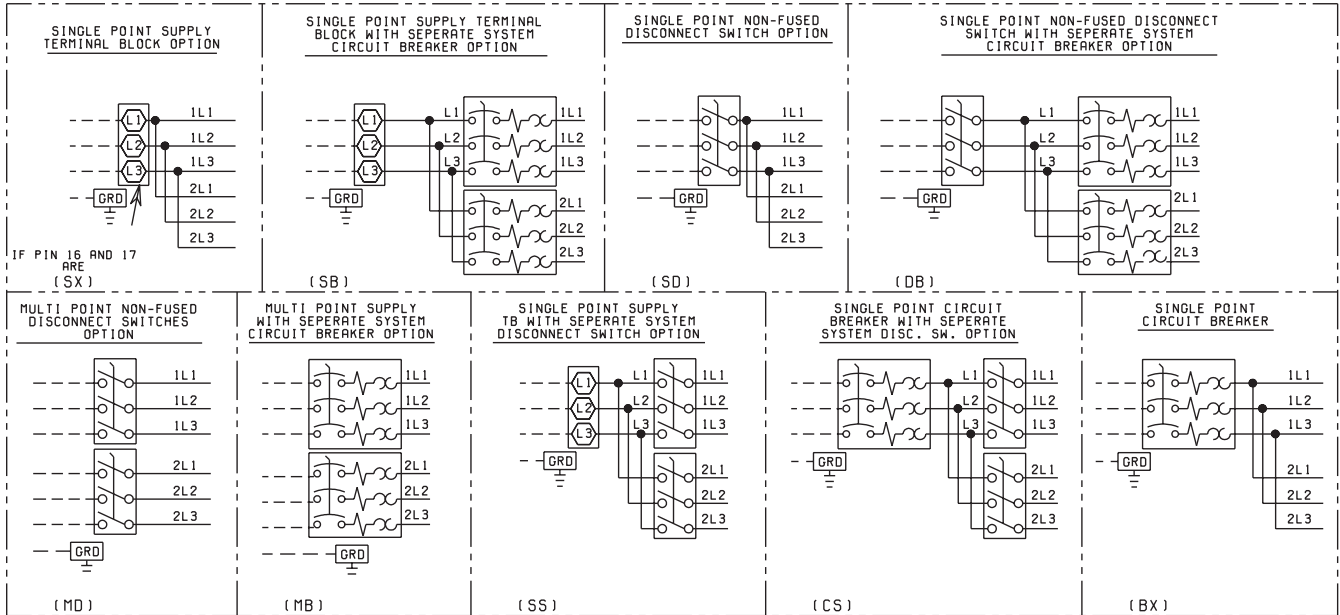

FIGURE 1 - CONTINUED

WIRING DIAGRAM WYE-DELTA START



NOTES:

1. Field wiring to be in accordance with the current edition of the National Electrical Code as well as all other applicable codes and specifications.
2. Contacts must be suitable for switching 24VDC. (Gold contacts recommended). Wiring shall NOT run in the same conduit with any line voltage (Class I) wiring.
3. To cycle unit on and off automatically with contacts shown, install a cycling device in series with the flow switch. See note 2 for contact rating and wiring specifications.
4. To stop unit (emergency stop) with contacts other than those shown, install the stop contact between terminals 5 and 1. If a stop device is not installed, a jumper must be connected between terminals 5 and 1. Device must have a minimum contact rating of 6A at 115 Volts AC.
5. Contacts are rated at 115V, 100VA, resistive load only, and must be suppressed at load by user.
6. See Installation, Operation, and Maintenance manual when optional equipment is used.

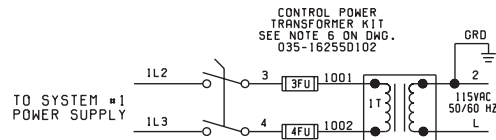

CONTROL POWER SUPPLY

UNIT VOLTAGE	CONTROL POWER SUPPLY	MIN. CIRCUIT AMP	MAX DUAL ELEMENT FUSE SIZE	NON FUSED DISC. FUSE SIZE
ALL MODELS W/O TRANS	115-1-50/60	20A	20A 250V	30A 240V
MODELS WITH TRANS.	-17	15A	15A 250V	30A 240V
	-28	15A	15A 250V	30A 240V
	-46	8A	8A 600V	30A 480V
	-58	8A	8A 600V	30A 600V

FIG. 1 - ELEMENTARY DIAGRAM - WYE-DELTA START

WIRING DIAGRAM WYE-DELTA START

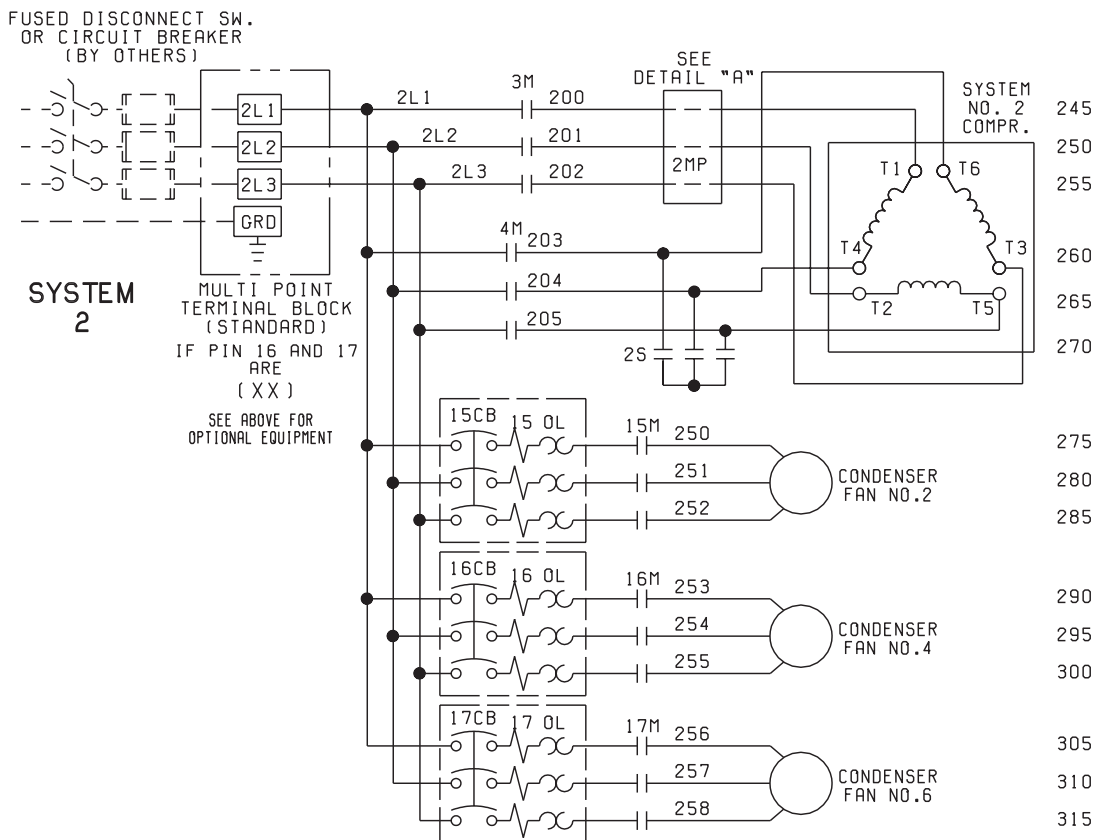
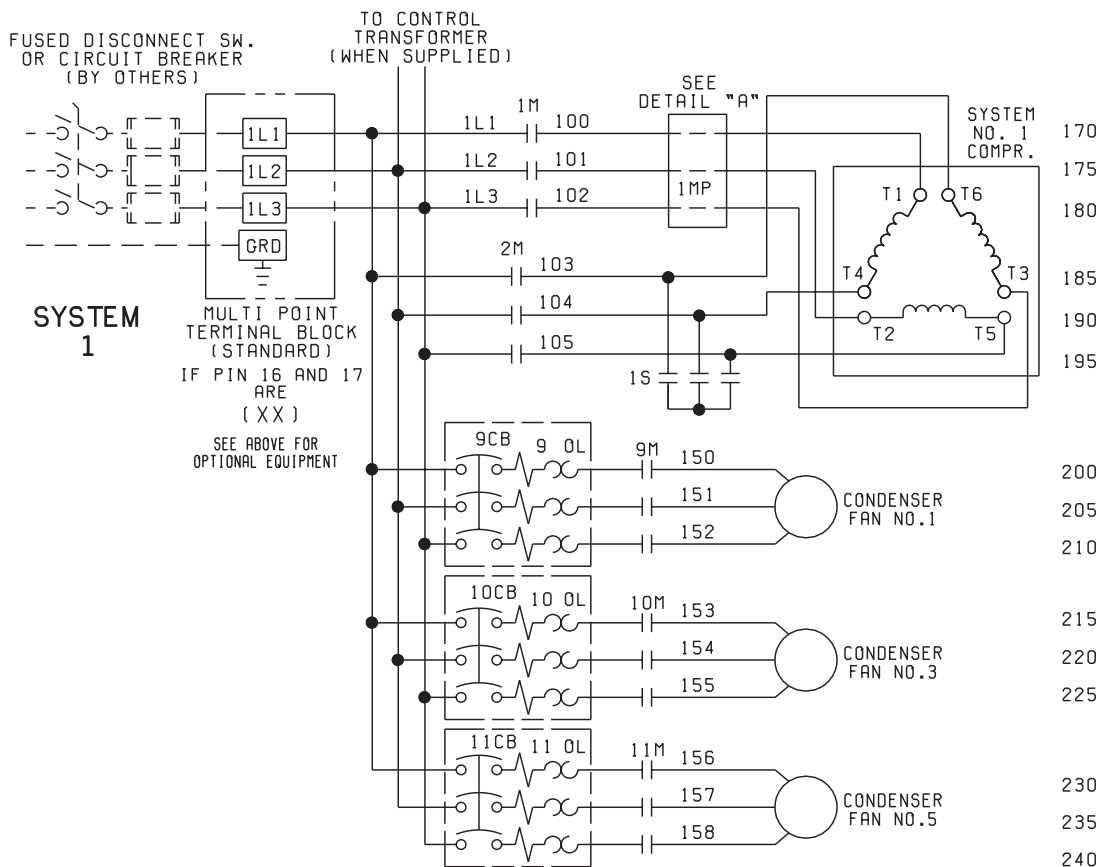

ELEMENTARY DIAGRAM
Y-CAS (STYLE F)
STANDARD AND REMOTE EVAPORATOR UNITS

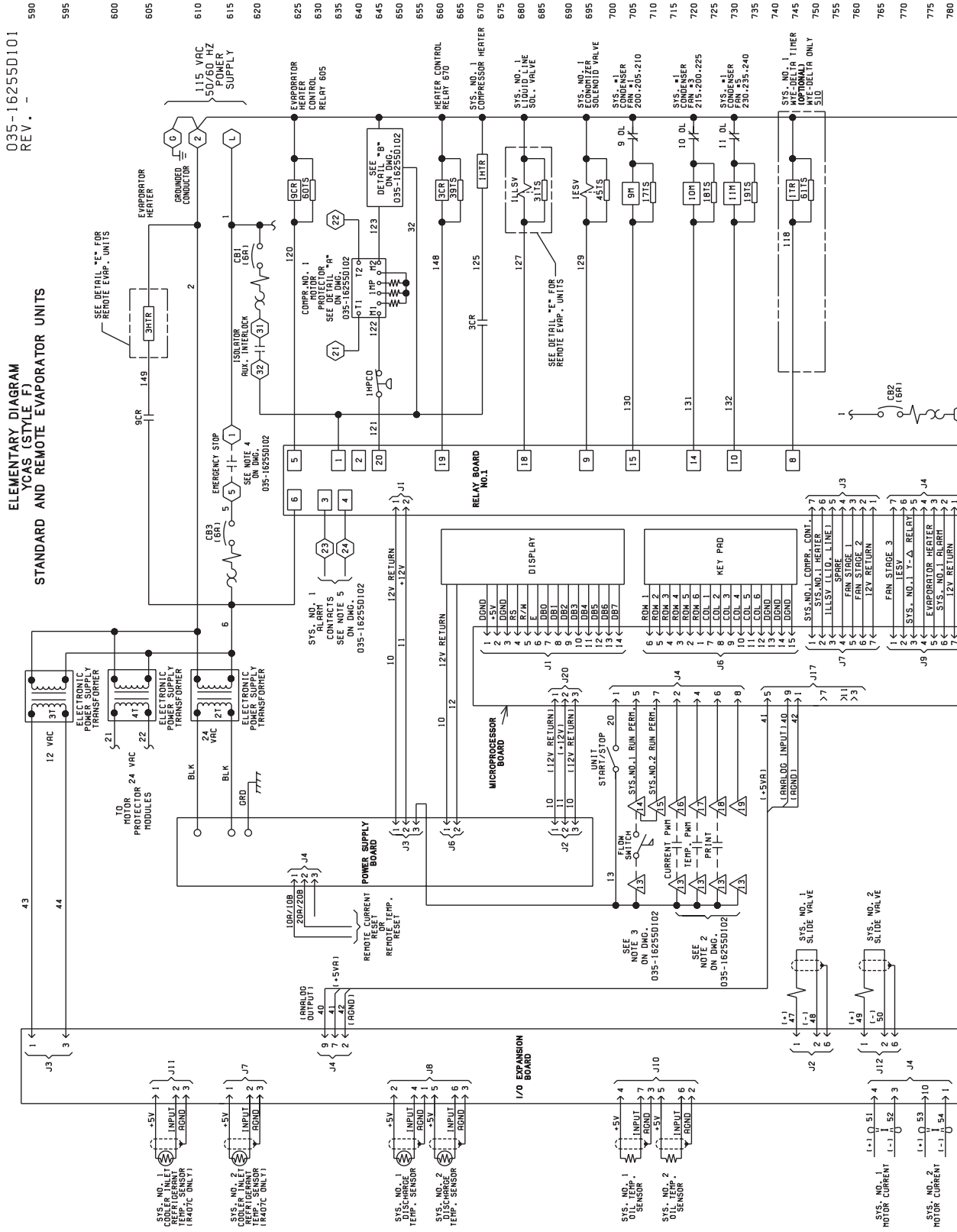

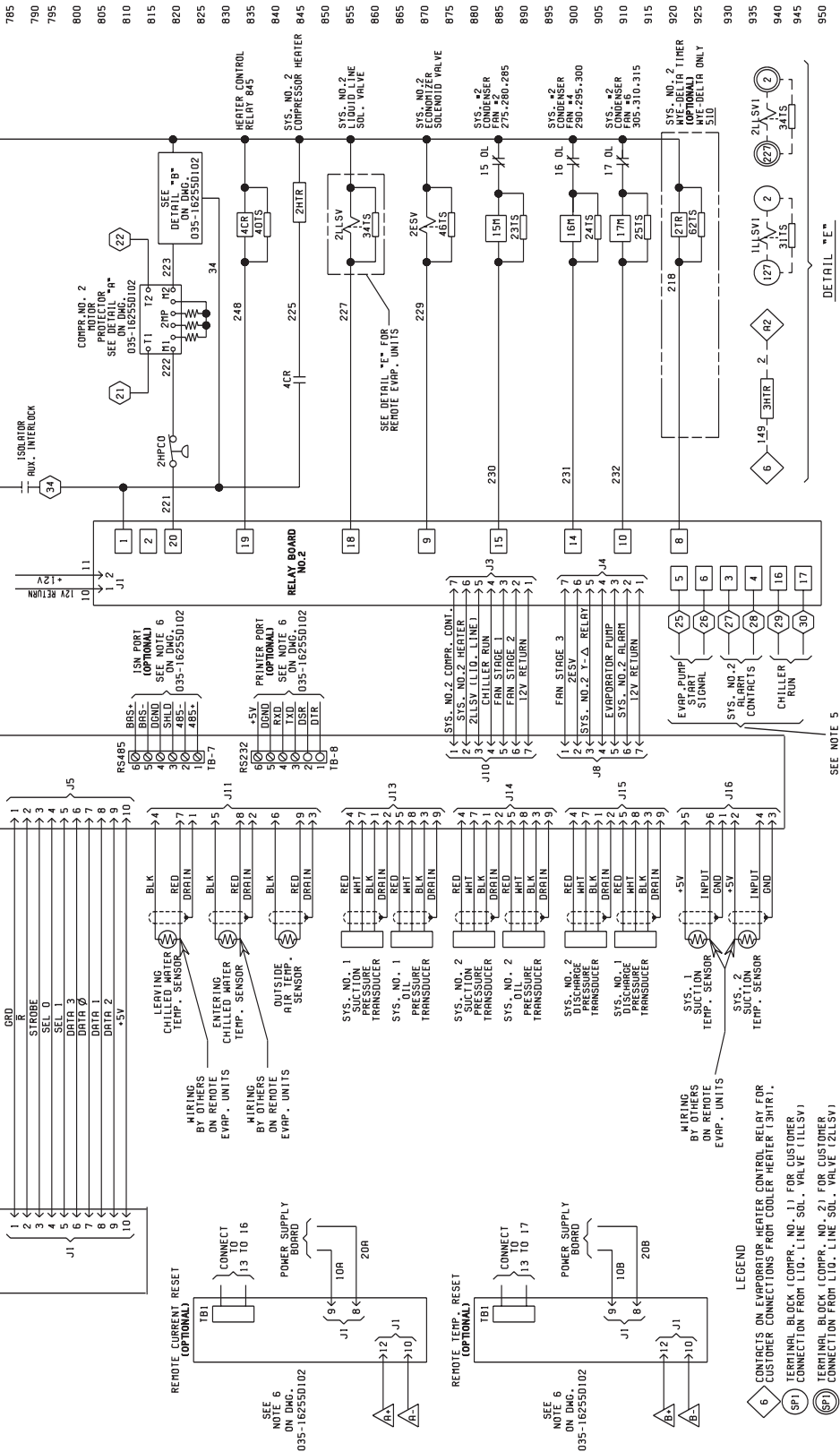

CAUTION:
No Controls (relays, etc.) should be mounted in the Smart Panel enclosure or connected to power supplies in the control panel. Additionally, control wiring not connected to the Smart Panel should not be run through the cabinet. This could result in nuisance faults.

CAUTION:
Any inductive devices (relays) wired in series with the flow switch for start/stop, into the Alarm circuitry, or pilot relays for pump starters wired through motor contactor auxiliary contacts must be suppressed with YORK P/N 031-00808-000 suppressor across the relay/contact coil.

Any contacts connected to flow switch inputs or BAS inputs on terminals, must be suppressed with a YORK P/N 031-00808-000 suppressor across the relay/contact coil.

CAUTION:
Control wiring connected to the control panel should never be run in the same conduit power wiring.

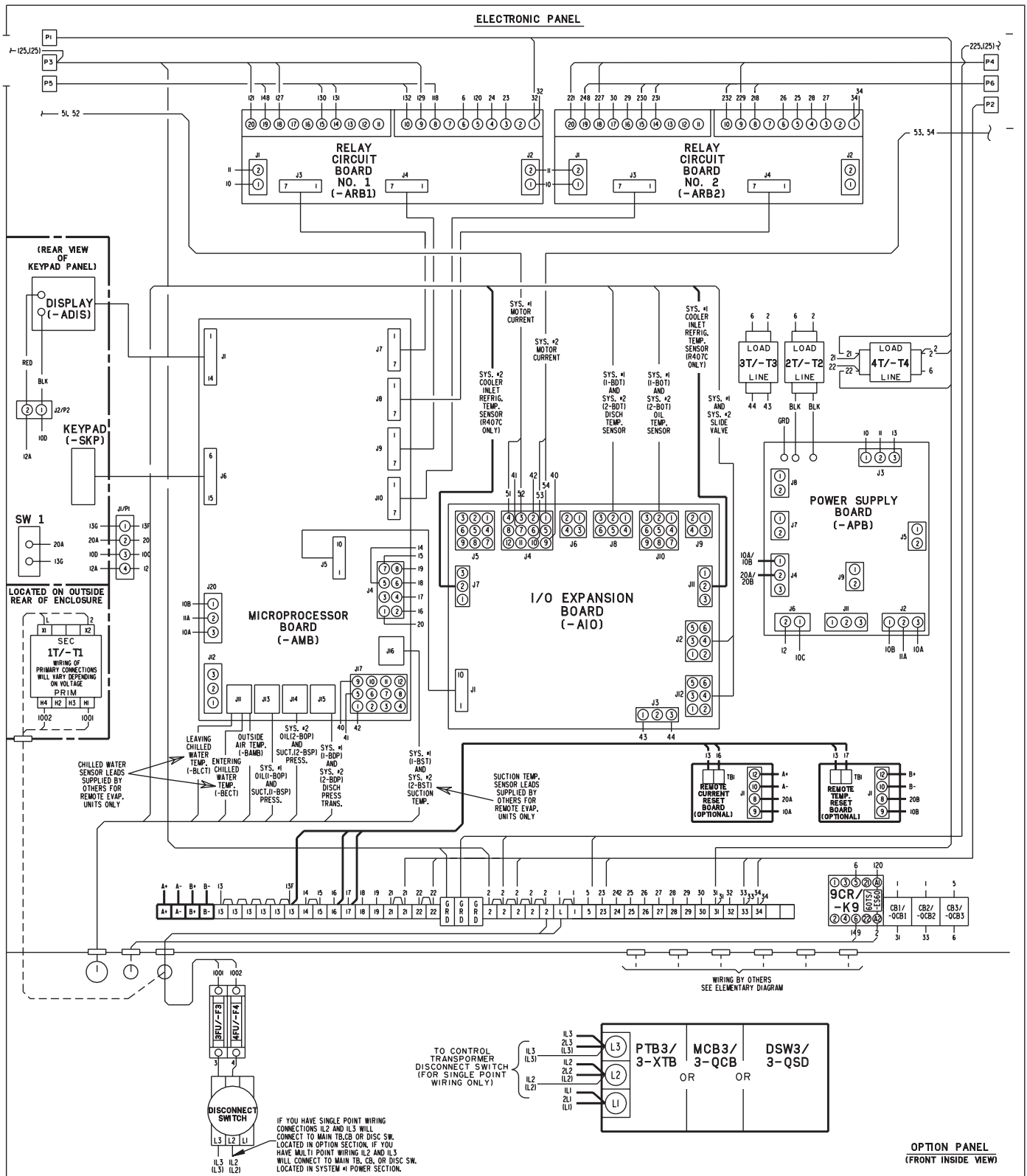

FIGURE 2 - PANEL COMPONENT LOCATIONS

LEGEND

CONNECTION DIAGRAM, ELEC. BOX YCAS 75-120 (STYLE F) STANDARD AND REMOTE EVAP. UNITS

1CR THRU 4CR, 9CR/ -K1 THRU -K4, -K9	-CONTROL RELAYS
CB1, CB2, CB3/ -QCB1, -QBC2, -QCB3	-CIRCUIT BREAKERS
9CB THRU 11CB	-OVERLOAD CIRCUIT BREAKERS (SYS. #1)
15CB THRU 17CB	-OVERLOAD CIRCUIT BREAKERS (SYS. #2)
9 OL THRU 11 OL	-MOTOR OVERLOADS (SYS. #1)
15 OL THRU 17 OL	-MOTOR OVERLOADS (SYS. #2)
-QFCB9 THRU -QFCB11	-MOTOR OVERLOADS W/OVERLOAD CIRCUIT BREAKERS (SYS. #1)
-QFCB15 THRU -QFCB17	-MOTOR OVERLOADS W/OVERLOAD CIRCUIT BREAKERS (SYS. #2)
3FU, 4FU/ -F3, -F4	-TRANSFORMER FUSE (OPTIONAL)

LEGEND

1M, 3M/ 1-KLC OR 1-KALC, 2-KLC OR 2-KALC	-COMPRESSOR CONTACTORS
2M, 4M/ 1-KDC, 2-KDC	-COMPRESSOR CONTACTORS
1S, 2S/ 1-KSC, 2-KSC	-COMPRESSOR CONTACTORS
9M THRU 11M/ -KF9 THRU -KF11 (SYS. #1)	-CONDENSER FAN CONTACTORS
15M THRU 17M/ -KF15 THRU -KF17 (SYS. #2)	-CONDENSER FAN CONTACTORS
1MP/1-FMP	-MOTOR PROTECTOR (SYS. #1)
2MP/2-FMP	-MOTOR PROTECTOR (SYS. #2)
1T/-T1	-CONTROL TRANSFORMER 2KVA (OPTIONAL)

2T, 3T, 4T/ -T2, -T3, -T4	-MICRO PANEL TRANSFORMERS
1TR, 2TR/ -K10, -K11	-TIMER RELAYS
TS/-ES	-TRANSIENT SUPPRESSORS
PTB1, PTB2/ 1-XTB, 2-XTB	-POWER TERMINAL BLOCK
MCB1, MCB2/ 1-QCB, 2-QCB	-MOTOR CIRCUIT BREAKER
DSW1, DSW2/ 1-QSD, 2-QSD	-DISCONNECT SERVICE SWITCH
—	-WIRING BY YORK
- - - - -	-WIRING BY OTHERS
— — — — —	-OPTIONAL WIRING AND/OR COMPONENTS

J1, J2, J3, J4. — POWER PANEL
J5 & J6

P1, P2, P3,
P4, P5, & P6 — ELECTRONIC (MICRO) PANEL

NOTE: WIRE NUMBERS IDENTIFIED IN
(PARENTHESIS) INDICATE THE
ACTUAL HARNESS CODE STAMPED
ON THE WIRE.

PLUG NO.	WIRE NO.	PLUG PIN NO.
P1	21	1
	2	2
	22	3
	31	4
	32	5

PLUG NO.	WIRE NO.	PLUG PIN NO.
P2	21	1
	2	2
	22	3
	33	4
	34	5

PLUG NO.	WIRE NO.	PLUG PIN NO.
P3	2	1
	GRD	2
	125	4
	129	5
	127	6
	121	11
		12

PLUG NO.	WIRE NO.	PLUG PIN NO.
P4	2	1
	GRD	2
	125	3
	227	4
	229	5
	221	11
		12

PLUG NO.	WIRE NO.	PLUG PIN NO.
P5	130	1
	131	2
	132	3
	148	4
	118	6

PLUG NO.	WIRE NO.	PLUG PIN NO.
P6	230	1
	231	2
	232	3
	248	4
	218	6

PLUG NO.	WIRE NO.	PLUG PIN NO.
J1	21	1
	2	2
	22	3
	3Y	4
	3X	5

PLUG NO.	WIRE NO.	PLUG PIN NO.
J2	21	1
	2	2
	22	3
	3Y	4
	3X	5

PLUG NO.	WIRE NO.	PLUG PIN NO.
J3	2	1
	GRD	2
	25	4
	129A	5
	127A	6
	121A	11
		12

PLUG NO.	WIRE NO.	PLUG PIN NO.
J4	2	1
	GRD	2
	25	3
	227A	4
	229A	5
	221A	11
	12	

PLUG NO.	WIRE NO.	PLUG PIN NO.
J5	30	1
	31	2
	32	3
	48	4
	18	6

PLUG NO.	WIRE NO.	PLUG PIN NO.
J6	30	1
	31	2
	32	3
	48	4
	18	6

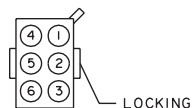

HOUSING - CONNECTOR
(J1, J2, J5, & J6)
WIRING END

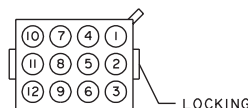







HOUSING - CONNECTOR
(J3, J4)
WIRING END

NOTES:

1. FIELD WIRING TO BE IN ACCORDANCE WITH THE CURRENT EDITION OF THE NATIONAL ELECTRICAL CODE AS WELL AS ALL OTHER APPLICABLE CODES AND SPECIFICATIONS.
2. CONTACTS MUST BE SUITABLE FOR SWITCHING 24VDC, (GOLD CONTACTS RECOMMENDED). WIRING SHALL NOT BE RUN IN THE SAME CONDUIT WITH ANY LINE VOLTAGE (CLASS 1) WIRING.
3. TO CYCLE UNIT ON AND OFF AUTOMATICALLY WITH CONTACT SHOWN, INSTALL A CYCLING DEVICE IN SERIES WITH THE FLOW SWITCH. SEE NOTE 2 FOR CONTACT RATING AND WIRING SPECIFICATIONS.
4. TO STOP UNIT (EMERGENCY STOP) WITH CONTACTS OTHER THAN THOSE SHOWN, INSTALL THE STOP CONTACT BETWEEN TERMINALS 5 AND 1. IF A STOP DEVICE IS NOT INSTALLED, A JUMPER MUST BE CONNECTED BETWEEN TERMINALS 5 AND 1. DEVICE MUST HAVE A MINIMUM CONTACT RATING OF 6A AT 115VOLTS A.C.
5. CONTACTS ARE RATED AT 115V, 100VA, RESISTIVE LOAD ONLY, AND MUST BE SUPPRESSED AT LOAD BY USER.
6. SEE INSTALLATION, OPERATION AND MAINTENANCE MANUAL WHEN OPTIONAL EQUIPMENT IS USED.

LEGEND

- TS TRANSIENT VOLTAGE SUPPRESSION
-  TERMINAL BLOCK FOR CUSTOMER CONNECTIONS
-  TERMINAL BLOCK FOR CUSTOMER LOW VOLTAGE (CLASS 2) CONNECTIONS. SEE NOTE 2.
-  TERMINAL BLOCK FOR YORK CONNECTIONS ONLY
-  WIRING AND COMPONENTS BY YORK
-  OPTIONAL EQUIPMENT
-  WIRING AND/OR COMPONENTS BY OTHERS

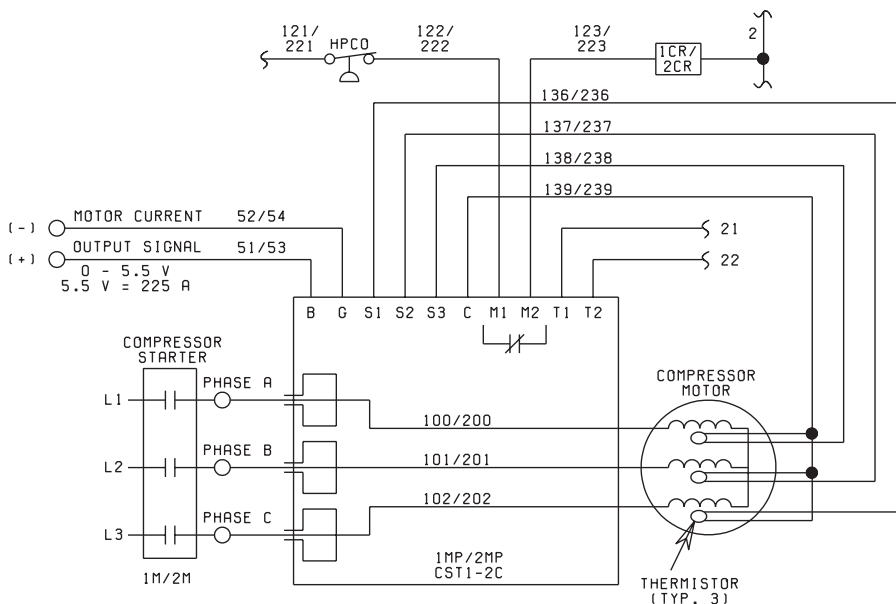

DETAIL A

CONNECTION DIAGRAM (SYSTEM WIRING)

CONNECTION DIAGRAM SYSTEM WIRING
 YCAS 090-120
 YCAS 283-343
 STANDARD & REMOTE EVAP. UNITS

035-16255DI05
 REV. -

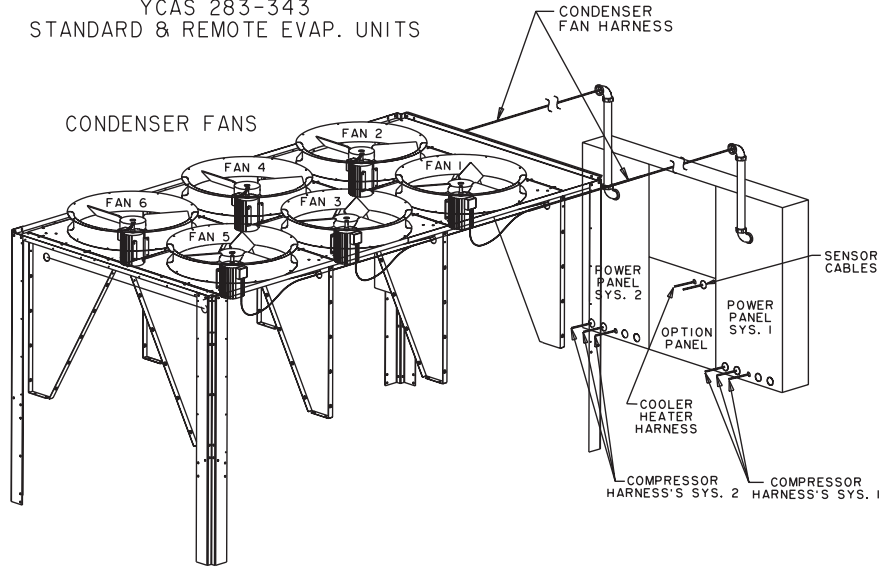
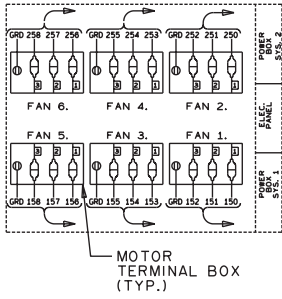

LEGEND

- 1 HPCO SYS. No.1 HIGH PRESS. CUTOUT
- 2 HPCO SYS. No.2 HIGH PRESS. CUTOUT
- 1 HTR SYS. No.1 COMPR. CRANKCASE HEATER
- 2 HTR SYS. No.2 COMPR. CRANKCASE HEATER
- 3 HTR COOLER HEATER
- 1 LLSV SYS. No.1 LIQUID LINE SOLENOID VALVE (UNIT IDENT)
- 2 LLSV SYS. No.2 LIQUID LINE SOLENOID VALVE (UNIT IDENT)
- 1 ESV ECONOMIZER SOLENOID VALVE (UNIT IDENT)
- 2 ESV ECONOMIZER SOLENOID VALVE (UNIT IDENT)
- TXV 1 SYS. No.1 THERMAL EXPANSION VALVE (UNIT IDENT)
- TXV 2 SYS. No.2 THERMAL EXPANSION VALVE (UNIT IDENT)

COOLER

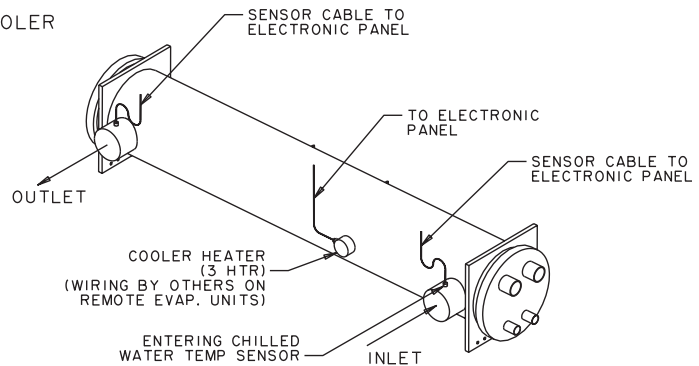

COMPRESSORS (SYSTEMS 1 & 2)

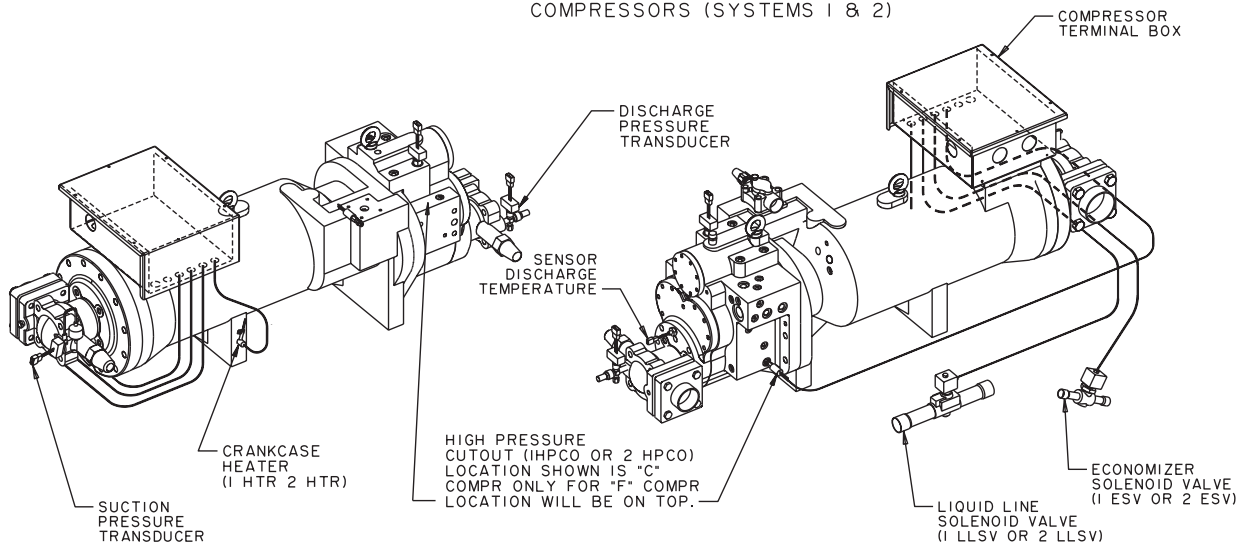

COMPRESSOR TERMINAL BOX

SYSTEM I & 2 WYE-DELTA-START
2 POWER HARNESS UNITS

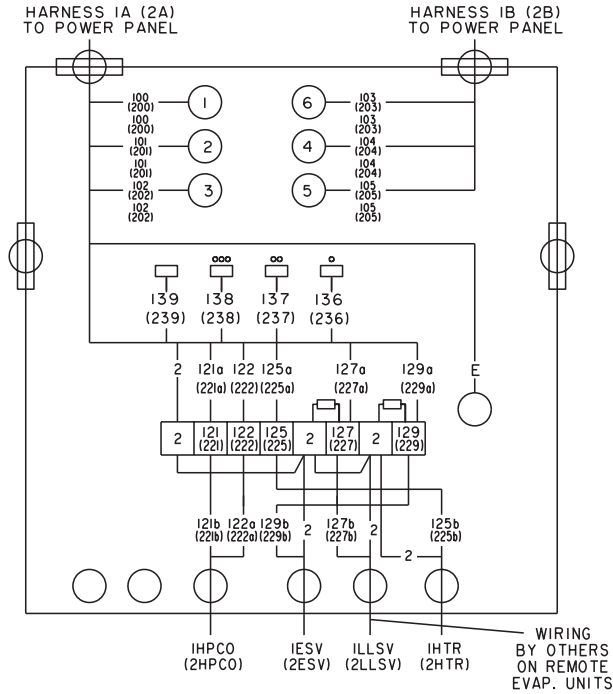

SYSTEM I & 2 WYE-DELTA-START
2 POWER HARNESS UNITS
W/ CONTROL HARNESS

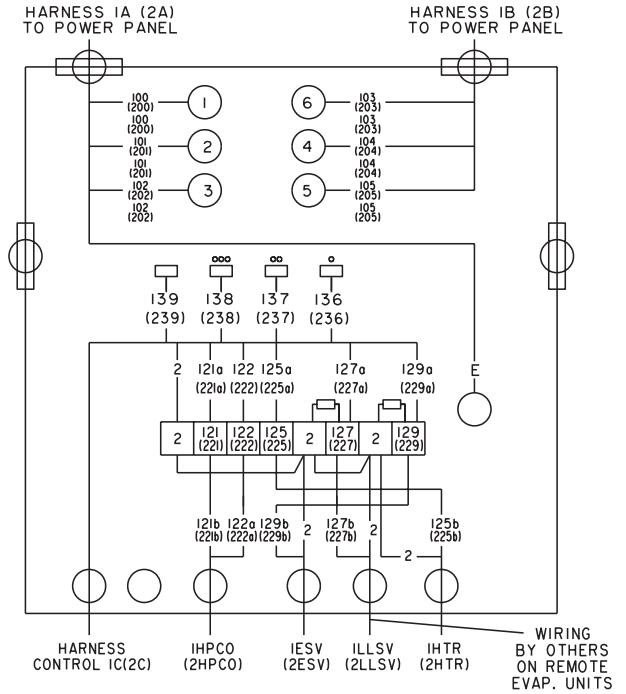

SYSTEM I & 2 ACROSS THE LINE
1 POWER HARNESS UNITS
W/ CONTROL HARNESS

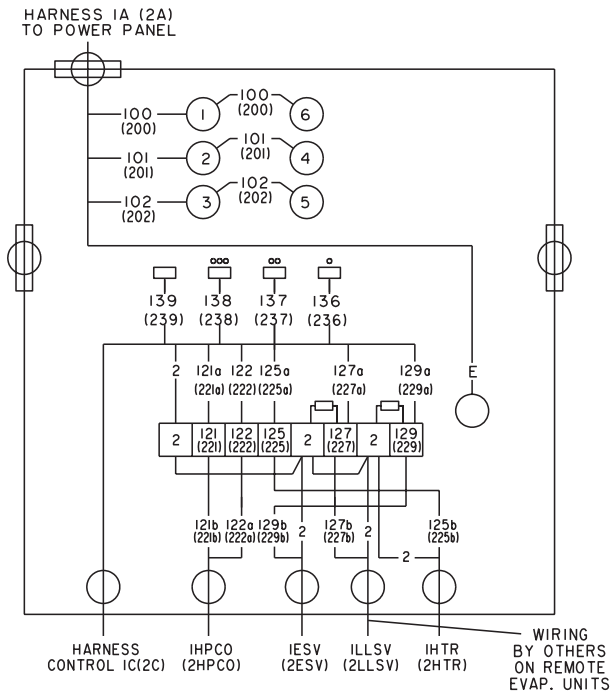

SYSTEM I & 2 ACROSS THE LINE
2 POWER HARNESS UNITS
W/ CONTROL HARNESS

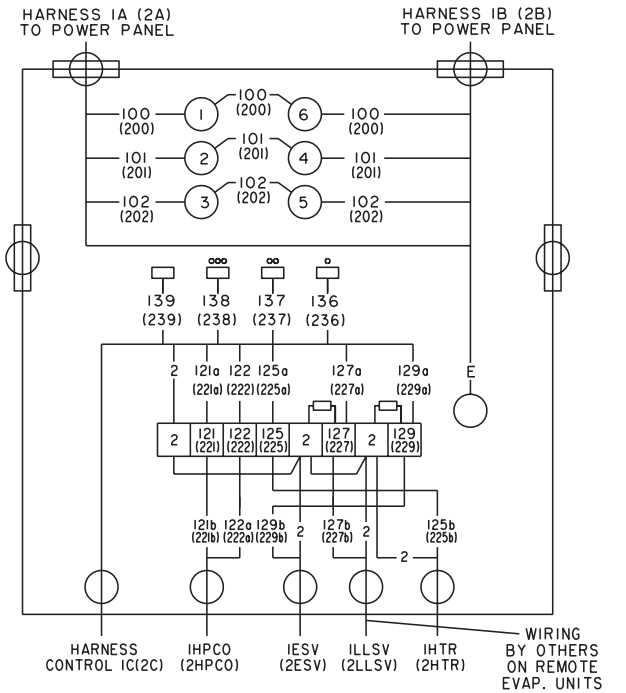

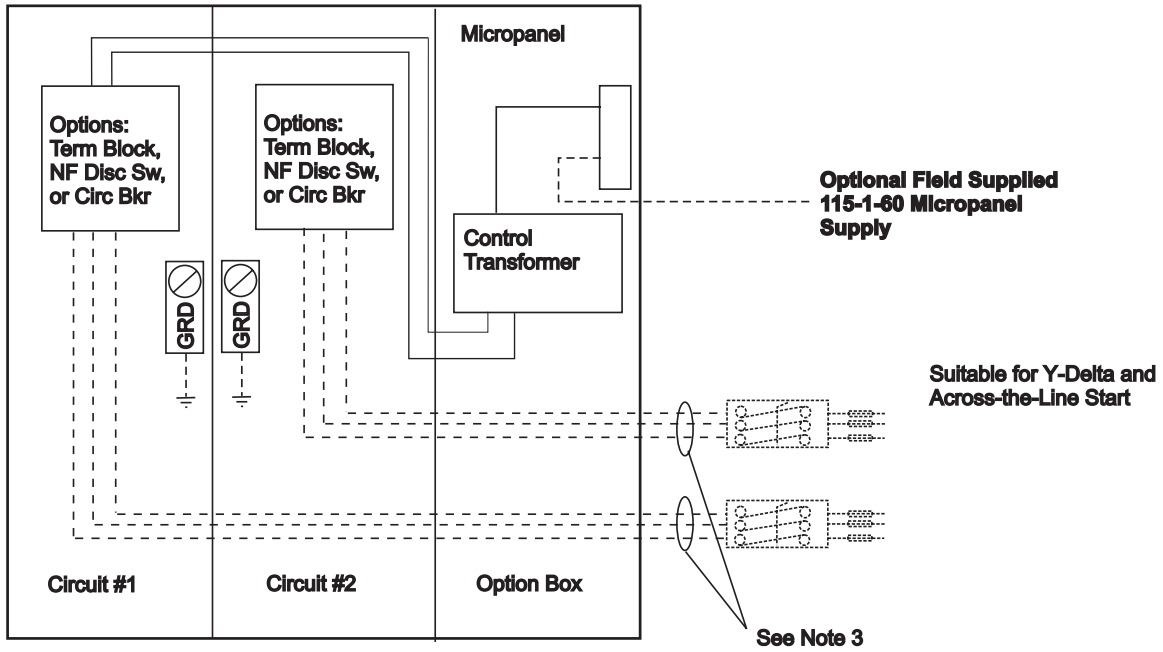

FIG. 3 - MULTIPLE POINT POWER SUPPLY CONNECTION

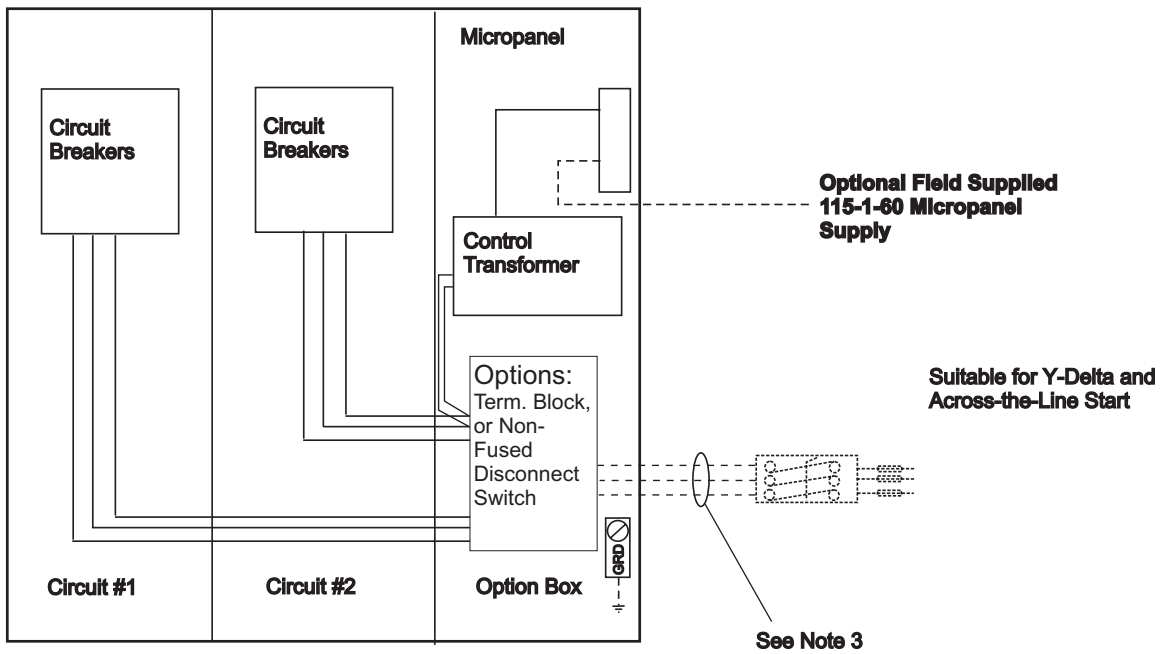

FIG. 4 - OPTIONAL SINGLE POINT POWER SUPPLY WITH INDIVIDUAL SYSTEM CIRCUIT BREAKERS

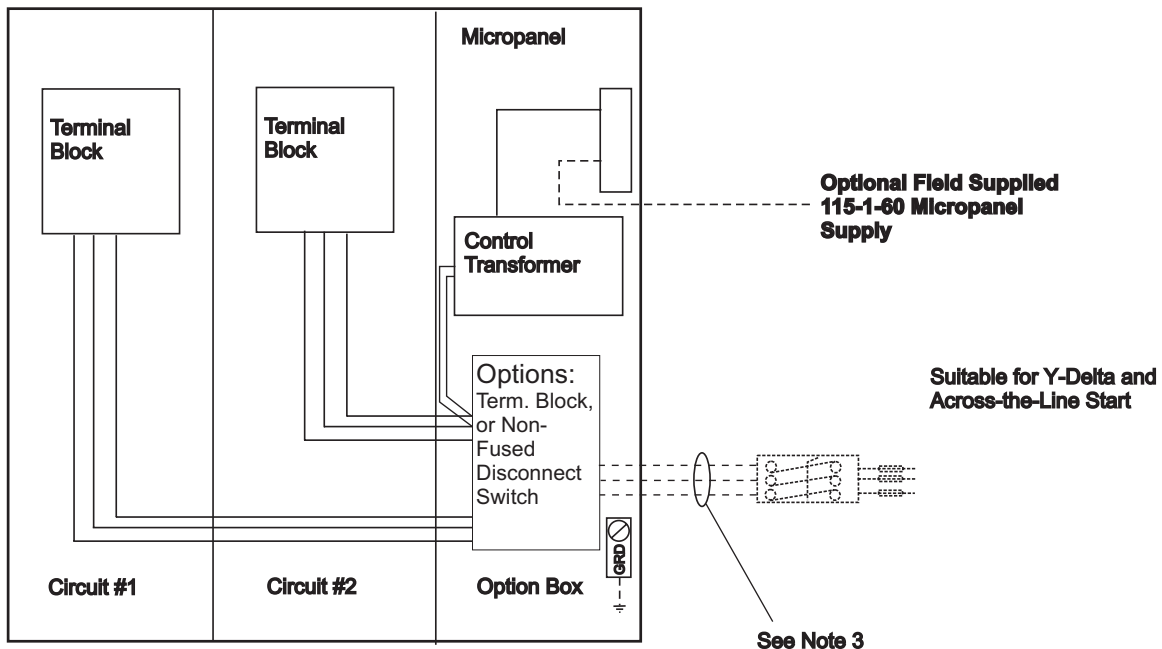

FIG. 5 - OPTIONAL SINGLE-POINT POWER SUPPLY CONNECTION WITH FIELD SUPPLIED CIRCUIT PROTECTION

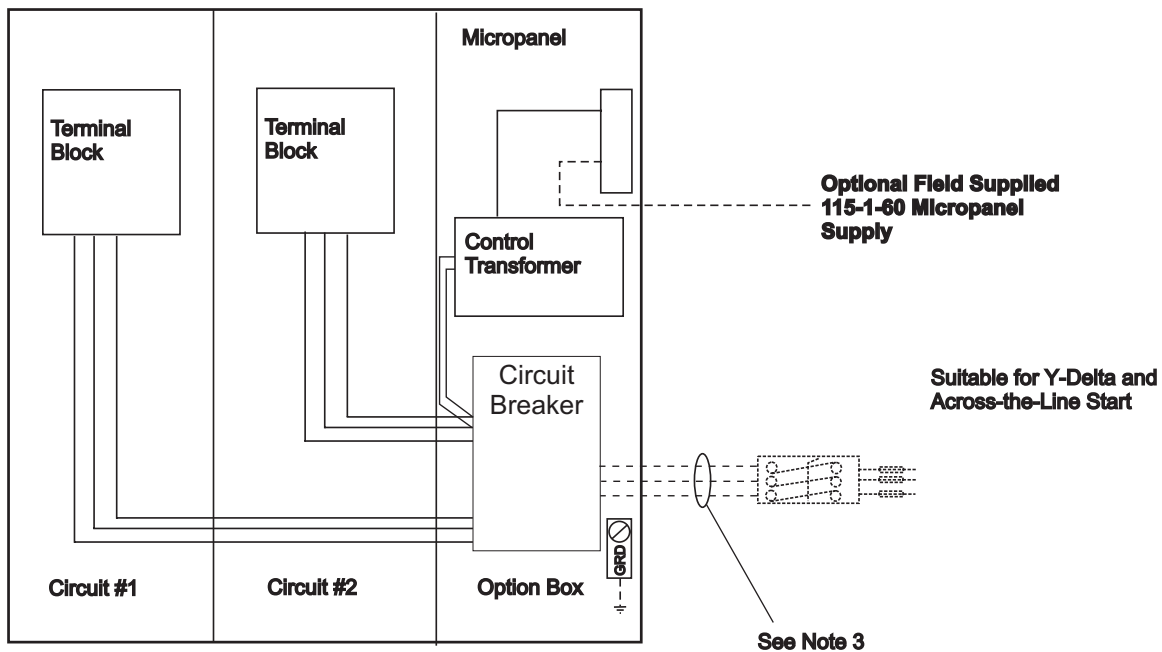

FIG. 6 - OPTIONAL SINGLE-POINT POWER SUPPLY WIRING TO FACTORY CIRCUIT BREAKER



P.O. Box 1592, York Pennsylvania USA 17405-1592
Copyright © by York International Corporation 2000

(717) 771-7890
www.york.com

Subject to change without notice. Printed in the USA
ALL RIGHTS RESERVED

Form 201.18-W5 (200)
New Release

RPC 2M 300 1.96
Code: SN5