



MILLENNIUM™
AIR COOLED SCREW LIQUID CHILLERS
MODELS YCAS STYLE 'F'

WIRING DIAGRAM

Supersedes: Nothing

Form 201.18-W3 (899)

MODELS YCAS0250 THROUGH YCAS0330



28971AR



200, 230, 380,
460, & 575 Models

TABLE OF CONTENTS

Nomenclature	3
Electrical Data	4
60 Hz	4
50 Hz	6
Power Wiring Possibilities	10
Systems 1 and 2 Wiring Diagrams	14
Fig. 1 - Elementary Diagram	14
Fig. 2 - Elementary Diagram	15
Standard Compressor Power Supplies	16
Fig. 3 - Across-The-Line Start	16
Fig. 4 - Wye-Delta Start	17
System 3 Wiring Diagrams	16
Fig. 5 - Elementary Diagram, Across-The-Line Start	18
Fig. 6 - Connection Diagram	20
Fig. 7 - Connection Diagram (continued)	22
Fig. 8 - Connection Diagram (continued)	23
Fig. 9 - Compressor Terminal Box	24
Fig. 10 - Compressor Terminal Box	25
DXST Direct Drive	26
Fig. 11 - Elementary Diagram, Detail A	26
Fig. 12 - Elementary Diagram, Detail B	27
Fig. 13 - Elementary Diagram, Detail C	28
Connection Diagram System Wiring	29
Control Power Transformer Kit (Optional)	31

WARNING

HIGH VOLTAGE
is used in the operation of this equipment
DEATH OR SERIOUS INJURY

may result if personnel fail to observe precautions.

Work on electronic equipment should not be undertaken unless the individual(s) has (have) been trained in the proper maintenance of the equipment and is (are) familiar with its potential hazards.

Shut off power supply to equipment before beginning work and follow lockout procedures. When working inside equipment with power off, take special care to discharge every capacitor likely to hold dangerous potential.

Be careful not to contact high voltage connections when installing or operating this equipment.

LOW VOLTAGE

DO NOT be misled by the term "low voltage". Voltages as low as 50 volts may cause death.

NOMENCLATURE

The Model Number denotes the following characteristics of the unit:

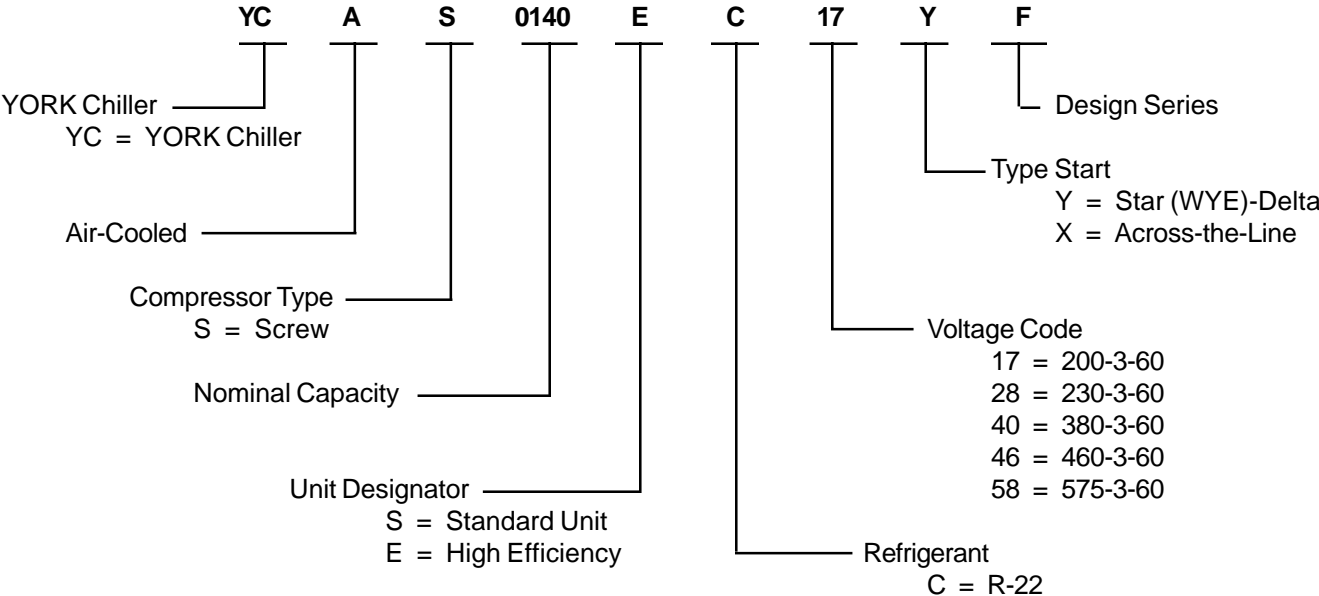

ELECTRICAL DATA (60 Hz)

60 Hz MULTIPLE POINT POWER SUPPLY CONNECTION

(Two Field Provided Power Supply Circuits to the Chiller. Field Connections to Factory provided Terminal Block (Std) or Disconnects (Opt) in the Options Panel. Circuit Breaker (opt¹⁰) in each of the two Motor Control Centers.)

Chiller Model YCAS	Electrical System #1 Field Supplied Wiring															
	Volts	Field Provided Power Supply				Factory Provided (Lugs) Wire Range ⁷		Compressor #1			Compressor #3			Fan ^{11, 12} Data		
		MCA ¹	Min NF Disc SW ²	Over-Current Protection ¹³		Standard Terminal block	Optional NF Disc. Switch	RLA	Y-Δ LRA	XL-LRA	RLA	Y-Δ LRA	XL-LRA	Qty	FLA (ea)	LRA (ea)
			Min. ^{3,5}	Max. ^{4,6}												
0250EC	380	387	400	450	500	(1)1/0-(2)4/0AWG	250-500 kcm	155	343	1,093	155	343	1,093	8	4.8	23.0
	460	320	400	400	400	(1)1/0-(2)4/0AWG	250-500 kcm	128	280	893	128	280	893	8	4.0	19.0
	575	257	400	300	350	(1)1/0-(2)4/0AWG	250-500 kcm	103	224	714	103	224	714	8	3.1	15.2
0270EC	380	477	600	600	700	(2) 2AWG-300kcm	(2) 250-500kcm	155	343	1,093	227	343	1,093	8	4.8	23.0
	460	390	400	450	500	(1)1/0-(2)4/0AWG	250-500 kcm	128	280	893	184	280	893	8	4.0	19.0
	575	312	400	350	450	(1)1/0-(2)4/0AWG	250-500 kcm	103	224	714	147	224	714	8	3.1	15.2
0300EC	380	473	600	600	600	(2) 2AWG-300kcm	(2) 250-500kcm	181	343	1,093	199	343	1,093	9	4.8	23.0
	460	390	400	450	500	(1)1/0-(2)4/0AWG	250-500 kcm	149	280	893	164	280	893	9	4.0	19.0
	575	311	400	350	400	(1)1/0-(2)4/0AWG	250-500 kcm	119	224	714	131	224	714	9	3.1	15.2
0330EC	380	524	600	600	700	(2)1/0AWG-500kcm	(2) 250-500kcm	197	343	1,093	227	343	1,093	9	4.8	23.0
	460	429	600	500	600	(2) 2AWG-300kcm	(2) 250-500kcm	163	280	893	184	280	893	9	4.0	19.0
	575	342	400	400	500	(1)1/0-(2)4/0AWG	250-500 kcm	130	224	714	147	224	714	9	3.1	15.2

NOTES

1. Minimum circuit ampacity (MCA) is based on 125% of the rated load amps for the largest motor plus 100% of the rated load amps for all other loads included in the circuit, per N.E.C. Article 430-24. If a Factory Mounted Control Transformer is provided, add the following to the system #1 MCA values in the YCAS Tables: -17, add 15 amps; -28, add 12 amps; -40, add 7 amps; -46, add 6 amps; -58, add 5 amps.
2. The recommended disconnect switch is based on a minimum of 115% of the summation rated load amps of all the loads included in the circuit, per N.E.C. 440 - 12A1.
3. Minimum fuse size is based on 150% of the largest motor RLA plus 100% of the remaining RLAs (U.L. Standard 1995, Section 36.1). Minimum fuse rating = (1.5 x largest compressor RLA) + other compressor RLAs + (# fans x each fan motor FLA).
4. Maximum dual element fuse size is based on 225% maximum plus 100% of the rated load amps for all other loads included in the circuit, per N.E.C. 440-22. Maximum fuse rating = (2.25 x largest compressor RLA) + other compressor RLAs + (# fans x each fan motor FLA).
5. Minimum circuit breaker is 150% maximum plus 100% of rated load amps included in the circuit, per circuit per U.L. 1995 Fig. 36.2. Minimum circuit breaker rating = (1.5 x largest compressor RLA) + other compressor RLAs + (# fans x each fan motor FLA).
6. Maximum circuit breaker is based on 225% maximum plus 100% of the rated load amps for all loads included in the circuit, per circuit, per U.L. 1995 Fig. 36.2. Maximum circuit breaker rating = (2.25 x largest compressor RLA) + other compressor RLAs + (# fans x each fan motor FLA).

Chiller Model YCAS	Electrical System #2 Field Supplied Wiring															
	Volts	Field Provided Power Supply				Factory Provided (Lugs) Wire Range		Compressor #2			Compressor #4			Fan ^{11, 12} Data		
		MCA ¹	Min NF Disc SW ²	Over-Current Protection ¹³		Standard Terminal block	Optional NF Disc. Switch	RLA	Y-Δ LRA	XL-LRA	RLA	Y-Δ LRA	XL-LRA	Qty	FLA (ea)	LRA (ea)
			Min. ^{3,5}	Max. ^{4,6}												
0250EC	380	213	200	300	350	2 AWG-300kcm	4 AWG-300kcm	155	343	1,093	-	---	---	4	4.8	23.0
	460	176	175	225	300	# 3-4/0 AWG	4 AWG-300kcm	128	280	893	-	---	---	4	4.0	19.0
	575	141	150	175	225	# 3-4/0 AWG	4 AWG-300kcm	103	224	714	-	---	---	4	3.1	15.2
0270EC	380	213	200	300	350	2 AWG-300kcm	4 AWG-300kcm	155	343	1,093	-	---	---	4	4.8	23.0
	460	176	175	225	300	# 3-4/0 AWG	4 AWG-300kcm	128	280	893	-	---	---	4	4.0	19.0
	575	141	150	175	225	# 3-4/0 AWG	4 AWG-300kcm	103	224	714	-	---	---	4	3.1	15.2
0300EC	380	250	250	300	400	2 AWG-300kcm	6 AWG-350kcm	181	343	1,093	-	---	---	5	4.8	23.0
	460	206	200	250	350	2 AWG-300kcm	4 AWG-300kcm	149	280	893	-	---	---	5	4.0	19.0
	575	164	175	200	250	# 3-4/0 AWG	6 AWG-350kcm	119	224	714	-	---	---	5	3.1	15.2
0330EC	380	270	400	350	450	(1)1/0-(2)4/0AWG	250-500 kcm	197	343	1,093	-	---	---	5	4.8	23.0
	460	224	225	300	350	2 AWG-300kcm	4 AWG-300kcm	163	280	893	-	---	---	5	4.0	19.0
	575	178	175	225	300	# 3-4/0 AWG	6 AWG-350kcm	130	224	714	-	---	---	5	3.1	15.2

7. The Incoming Wire Range is the minimum and maximum wire size that can be accommodated by unit wiring lugs. The (1), (2), or (3) indicate the number of termination points or lugs which are available per phase. Actual wire size and number of wires per phase must be determined based on ampacity and job requirements using N.E.C. wire sizing information. The above recommendations are based on the National Electric Code and using copper connectors only. Field wiring must also comply with local codes.
8. A ground lug is provided for each compressor system to accommodate field grounding conductor per N.E.C. Article 250-54. A control circuit grounding lug is also supplied. Incoming ground wire range is #6 - 350 MCM.
9. The field supplied disconnect is a "Disconnecting Means" as defined in N.E.C. 100.B, and is intended for isolating the unit from the available power supply to perform maintenance and troubleshooting. This disconnect is not intended to be a Load Break Device.
10. Two-compressor machines with single-point power connection, and equipped with Star-Delta compressor motor start, must also include Factory provided circuit breakers in each motor control center. All 3 & 4 compressor machines equipped with Star-Delta compressor motor start must also include Factory-provided circuit breakers in each motor control center.
11. Consult factory for Electrical Data on units equipped with "High Static Fan" Option. High Static Fans are 3.8 kW each.
12. FLA for "Low Noise Fan" motors: 200V = 8.0A, 230V = 7.8A, 380V = 4.4A, 460V = 3.6A, 575V = 2.9A.
13. Group Rated breaker must be HACR type for cUL Machines.

ELECTRICAL DATA (50 Hz)

50 Hz MULTIPLE POINT POWER SUPPLY CONNECTION

Two Field Provided Power Supply Circuits to the Chiller. Field Connections to Factory Provided Terminal Blocks (standard) or Disconnects (optional) in the Options Panel. Circuit Breakers (optional) in each of the two Motor Control Centers.

Chiller Model YCAS	ELECTRICAL SYSTEM #1 FIELD SUPPLIED WIRING															
	Volts	Field Provided Power Supply				Factory Provided (Lugs) Wire Range ⁷		Compressor #1 Data			Compressor #3 Data			Fan Data ^{11, 12}		
		MRC (MCA ¹)	Min NF Disc SW ²	Over-Current Protection		Standard Terminal Block	Optional NF Disc. Switch	RLA	Y-Δ LRA	XL-LRA	RLA	Y-Δ LRA	XL-LRA	Qty	FLA (ea)	LRA (ea)
0693SB	380	362	400	400	450	(1)1/0-(2)4/0AWG	250-500 kcm	140	283	907	124	283	907	7	4.6	17.1
0773SB	380	436	600	450	500	(2) 2AWG-300kcm	(2) 250-500kcm	140	283	907	183	283	907	7	4.6	17.1
0783EB	380	402	400	450	500	(1)1/0-(2)4/0AWG	250-500 kcm	124	283	907	168	283	907	8	4.6	17.1
0873EB	380	457	600	500	500	(2) 2AWG-300kcm	(2) 250-500kcm	168	283	907	168	283	907	8	4.6	17.1
0953EB	380	494	600	500	600	(2) 2AWG-300kcm	(2) 250-500kcm	183	283	907	183	283	907	8	4.6	17.1

* "Optional" Circuit Breakers are REQUIRED for units with CE mark.

NOTES

1. MRC is Maximum Running Current, the maximum continuous current at any operating point in the rating range. Also referred to as MCA, or Minimum Current Ampacity to be furnished by the installer.
2. The recommended disconnect switch is based on a minimum of 115% of the summation rated load amps of all the loads included in the circuit, per N.E.C. 440 - 12A1.
3. Minimum fuse size is based on 150% of the largest motor RLA plus 100% of the remaining RLAs (U.L. Standard 1995, Section 36.1). Minimum fuse rating = (1.5 x largest compressor RLA) + other compressor RLAs + (# fans x each fan motor FLA).
4. Maximum dual element fuse size is based on 225% maximum plus 100% of the rated load amps for all other loads included in the circuit, per N.E.C. 440-22. Maximum fuse rating = (2.25 x largest compressor RLA) + other compressor RLAs + (# fans x each fan motor FLA).
5. Minimum circuit breaker is 150% maximum plus 100% of rated load amps included in the circuit, per circuit per U.L. 1995 Fig. 36.2. Minimum circuit breaker rating = (1.5 x largest compressor RLA) + other compressor RLAs + (# fans x each fan motor FLA).
6. Maximum circuit breaker is based on 225% maximum plus 100% of the rated load amps for all loads included in the circuit, per circuit, per U.L. 1995 Fig. 36.2. Maximum circuit breaker rating = (2.25 x largest compressor RLA) + other compressor RLAs + (# fans x each fan motor FLA).

Chiller Model YCAS	ELECTRICAL SYSTEM #2 FIELD SUPPLIED WIRING															
	Volts	Field Provided Power Supply				Factory Provided (Lugs) Wire Range ⁷		Compressor #2 Data			Compressor #4 Data			Fan Data ^{11, 12}		
		MRC (MCA) ¹	Min NF Disc SW ²	Over-Current Protection		Standard* Terminal Block	Optional* NF Disc. Switch	RLA	Y-Δ LRA	XL-LRA	RLA	Y-Δ LRA	XL-LRA	Qty	FLA (ea)	LRA (ea)
0693SB	380	189	200	200	300	#3-4/0 AWG	4 AWG-300kcm	140	283	907	--	---	---	3	4.6	17.1
0773SB	380	189	200	200	300	#3-4/0 AWG	4 AWG-300kcm	140	283	907	--	---	---	3	4.6	17.1
0783EB	380	173	175	175	250	#3-4/0 AWG	4 AWG-300kcm	124	283	907	--	---	---	4	4.6	17.1
0873EB	380	228	250	250	350	2 AWG-300kcm	6 AWG-350kcm	168	283	907	--	---	---	4	4.6	17.1
0953EB	380	247	250	250	400	2 AWG-300kcm	6 AWG-350kcm	183	283	907	--	---	---	4	4.6	17.1

7. The Incoming Wire Range is the minimum and maximum wire size that can be accommodated by unit wiring lugs. The (1), (2), or (3) indicate the number of termination points or lugs which are available per phase. Actual wire size and number of wires per phase must be determined based on ampacity and job requirements using N.E.C. wire sizing information. The above recommendations are based on the National Electric Code and using copper connectors only. Field wiring must also comply with local codes.
8. A ground lug is provided for each compressor system to accommodate field grounding conductor per N.E.C. Article 250-54. A control circuit grounding lug is also supplied. Incoming ground wire range is #6 - 350 MCM.
9. The field supplied disconnect is a "Disconnecting Means" as defined in N.E.C. 100.B, and is intended for isolating the unit from the available power supply to perform maintenance and troubleshooting. This disconnect is not intended to be a Load Break Device.
10. Two-Compressor machines with single-point power connection, and equipped with Star-Delta Compressor motor starters, must also include Factory-provided circuit breakers in each motor control center. 3 & 4 Compressor machine equipped with Star-Delta compressor motor starter, must also include factory-provided circuit breakers in each motor control center.
11. Consult factory for Electrical Data on units equipped with "High Static Fan" Option. High Static Fans are 3.5 kW each.
12. FLA for "Low Noise Fan" motors is 4.1 A.

ELECTRICAL DATA

OPTIONAL SINGLE-POINT POWER SUPPLY CONNECTION AND INTERNAL UNIT CIRCUIT BREAKERS

(One Field Provided Power Supply Circuit to the chiller. Field connections to Power Terminal Block (standard) or Non-Fused Disconnect (option) in 'Option Panel'. Circuit Breakers in each Motor Control Center

CHILLER MODEL YCAS	VOLTS	FIELD SUPPLIED WIRING					FACTORY PROVIDED (LUGS) WIRE RANGE ⁷	
		FIELD PROVIDED POWER SUPPLY			OVER-CURRENT PROTECTION ¹³		TERMINAL BLOCK (LUGS) WIRE RANGE	NF DISC. SWITCH (LUGS) WIRE RANGE
		MCA ¹	MIN NF DISC SW ²		MIN. ^{3,5}	MAX. ^{4,6}		
0250EC	380	561	600		600	700	(2)1/0AWG-500kcm	(2) 250-500kcm
	460	464	600		500	500	(2) #2 AWG-300kcm	(2) 250-500kcm
	575	372	400		400	450	(2) # 3-4/0 AWG	250-500kcm
0270EC	380	651	800		800	800	(2)1/0AWG-500kcm	(3)2/0AWG-400kcm
	460	534	600		600	700	(2)1/0AWG-500kcm	(2) 250-500kcm
	575	427	600		500	500	(2) #2 AWG-300kcm	(2) 250-500kcm
0300EC	380	678	800		800	800	(3) #2 AWG-300kcm	(3)2/0AWG-400kcm
	460	559	600		600	700	(2)1/0AWG-500kcm	(2) 250-500kcm
	575	445	600		500	500	(2)1/0AWG-500kcm	(2) 250-500kcm
0330EC	380	745	800		800	800	(3) #2 AWG-300kcm	(3)2/0AWG-400kcm
	460	612	800		700	700	(2)1/0AWG-500kcm	(3)2/0AWG-400kcm
	575	487	600		600	600	(2) #2 AWG-300kcm	(2) 250-500kcm

LEGEND

ACR-LINE	ACROSS THE LINE START
C.B.	CIRCUIT BREAKER
D.E.	DUAL ELEMENT FUSE
DISC SW	DISCONNECT SWITCH
FACT CB	FACTORY-MOUNTED CIRCUIT BREAKER
FLA	FULL LOAD AMPS
HZ	HERTZ
MAX	MAXIMUM
MCA	MINIMUM CIRCUIT AMPACITY
MIN	MINIMUM
MIN NF	MINIMUM NON-FUSED
RLA	RUNNING LOAD AMPS
S.P. WIRE	SINGLE-POINT WIRING
Y-Δ	WYE-DELTA START
X-LRA	ACROSS-THE-LINE INRUSH LOCKED ROTOR AMPS
Y-LRA	WYE-DELTA INRUSH LOCKED ROTOR AMPS

VOLTAGE CODE

-17	= 200-3-60
-28	= 230-3-60
-40	= 380-3-60
-46	= 460-3-60
-58	= 575-3-60

ELECTRICAL SYSTEM #1 FIELD SUPPLIED WIRING									ELECTRICAL SYSTEM #2 FIELD SUPPLIED WIRING								
COMPRESSOR #1 DATA			COMPRESSOR #3 DATA			FAN DATA ^{11, 12}			COMPRESSOR #2 DATA			COMPRESSOR #4 DATA			FAN DATA ^{11, 12}		
RLA	Y-Δ LRA	XL-LRA	RLA	Y-Δ LRA	XL-LRA	QTY	FLA (EA)	LRA (EA)	RLA	Y-Δ LRA	XL-LRA	RLA	Y-Δ LRA	XL-LRA	QTY	FLA (EA)	LRA (EA)
155	343	1,093	155	343	1,093	8	4.8	23.0	155	343	1,093	--	---	---	4	4.8	23.0
128	280	893	128	280	893	8	4.0	19.0	128	280	893	--	---	---	4	4.0	19.0
103	224	714	103	224	714	8	3.1	15.2	103	224	714	--	---	---	4	3.1	15.2
155	343	1,093	227	343	1,093	8	4.8	23.0	155	343	1,093	--	---	---	4	4.8	23.0
128	280	893	184	280	893	8	4.0	19.0	128	280	893	--	---	---	4	4.0	19.0
103	224	714	147	224	714	8	3.1	15.2	103	224	714	--	---	---	4	3.1	15.2
181	343	1,093	199	343	1,093	9	4.8	23.0	181	343	1,093	--	---	---	5	4.8	23.0
149	280	893	164	280	893	9	4.0	19.0	149	280	893	--	---	---	5	4.0	19.0
119	224	714	131	224	714	9	3.1	15.2	119	224	714	--	---	---	5	3.1	15.2
197	343	1,093	227	343	1,093	9	4.8	23.0	197	343	1,093	--	---	---	5	4.8	23.0
163	280	893	184	280	893	9	4.0	19.0	163	280	893	--	---	---	5	4.0	19.0
130	224	714	147	224	714	9	3.1	15.2	130	224	714	--	---	---	5	3.1	15.2

CONTROL POWER SUPPLY (UNITS WITHOUT STANDARD CONTROL CIRCUIT TRANSFORMER)

NO. OF COMPRESSORS	CONTROL POWER SUPPLY	MCA (MAX LOAD CURRENT)	MAX DUAL ELEMENT FUSE SIZE	NON-FUSED DISCONNECT SWITCH SIZE
(Non-CE 50/60Hz)	115V-1Ø	30A	30A	30A
(CE 50Hz)	115V-1Ø	25A	30A	30A

POWER WIRING POSSIBILITIES

MULTIPLE POINT WITH SEPARATE SYSTEM CIRCUIT BREAKERS

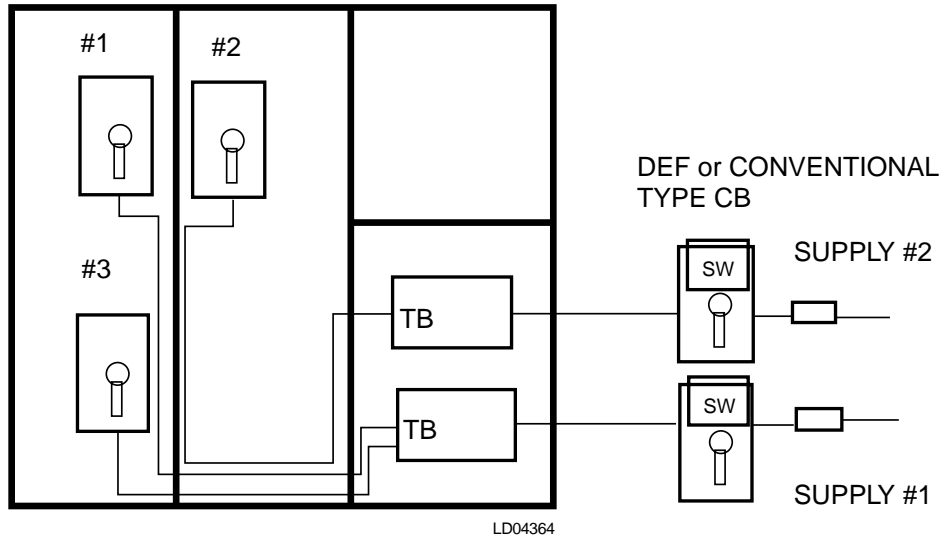

MULTIPLE POINT NON-FUSED DISCONNECTS WITH SEPARATE SYSTEM TERMINAL BLOCKS (SUITABLE FOR ACROSS-THE-LINE START ONLY)

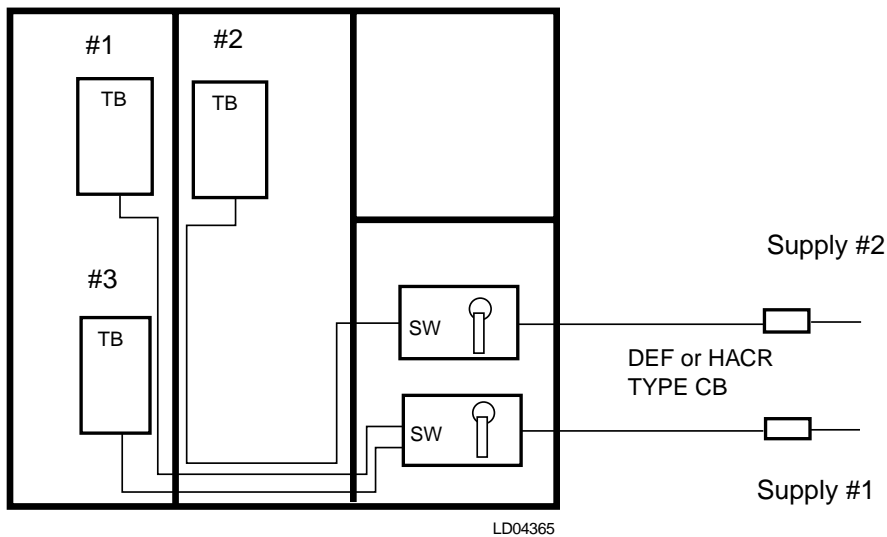

POWER WIRING POSSIBILITIES

MULTIPLE POINT NON-FUSED DISCONNECTS WITH SEPARATE SYSTEM CIRCUIT BREAKERS

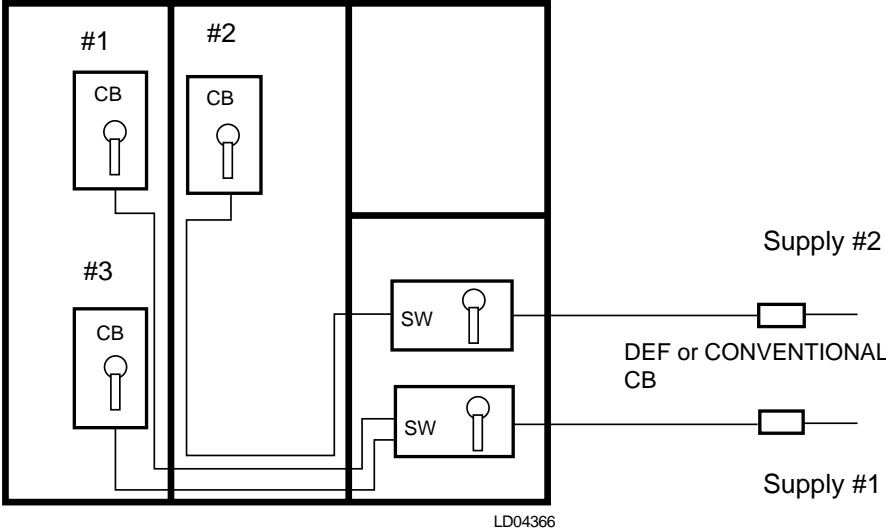

SINGLE POINT WITH NON-FUSED DISCONNECT SWITCH & SYSTEM CIRCUIT BREAKERS

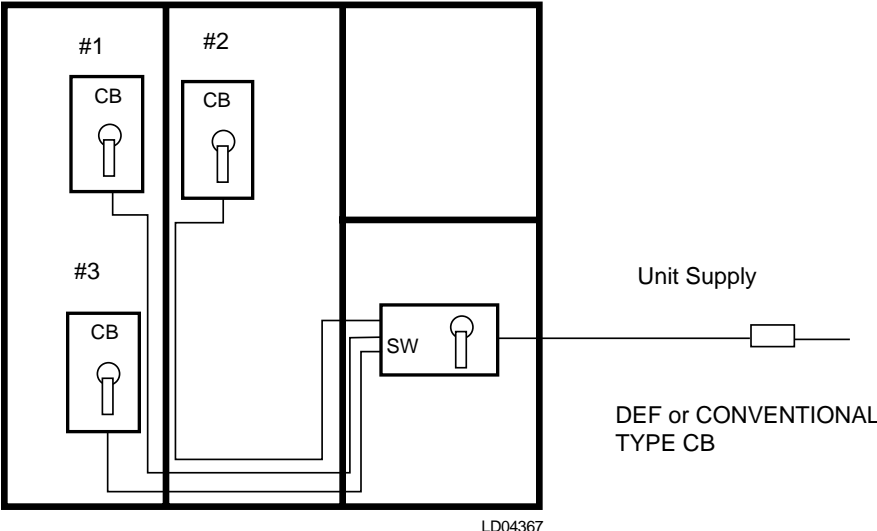

POWER WIRING POSSIBILITIES

SINGLE POINT WITH SEPARATE SYSTEM CIRCUIT BREAKERS

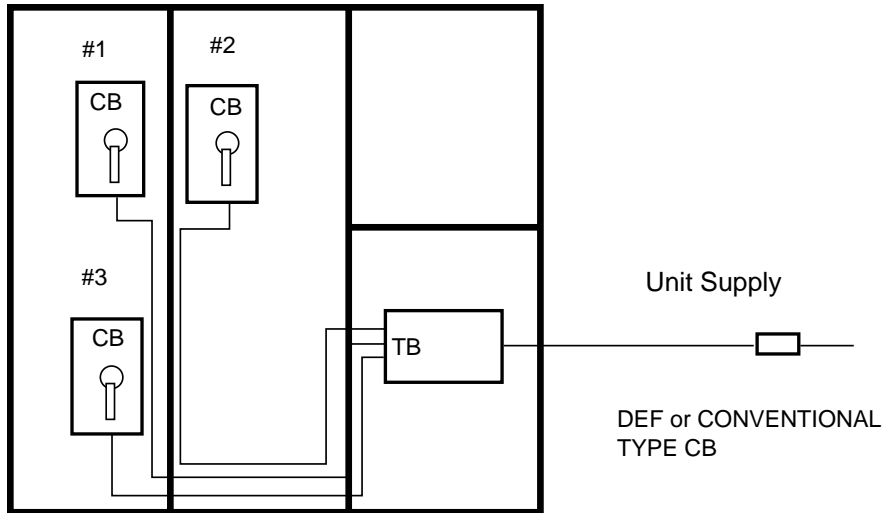

LD04368

MULTIPLE POINT WITH SEPARATE SYSTEM TERMINAL BLOCKS (SUITABLE FOR ACROSS-THE-LINE START ONLY)

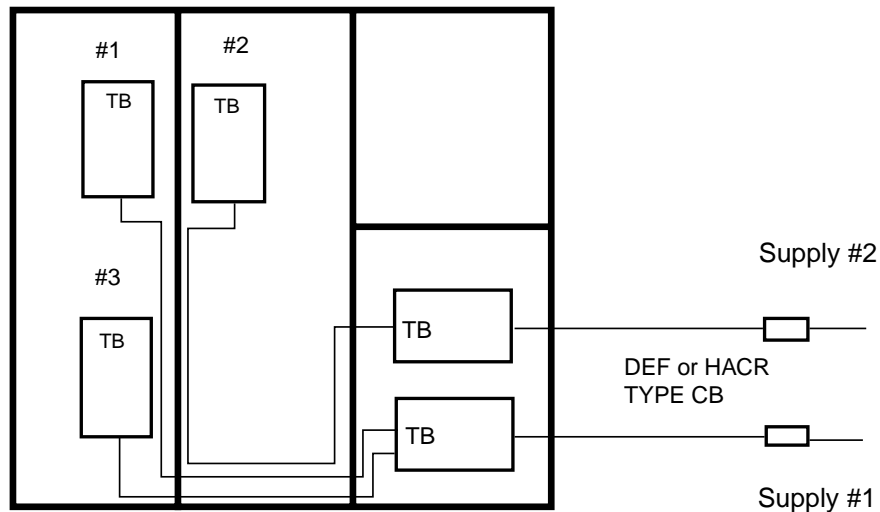

LD04369

POWER WIRING POSSIBILITIES

CONTROL (120-1-60) SUPPLY VIA STANDARD CONTROL TRANSFORMER

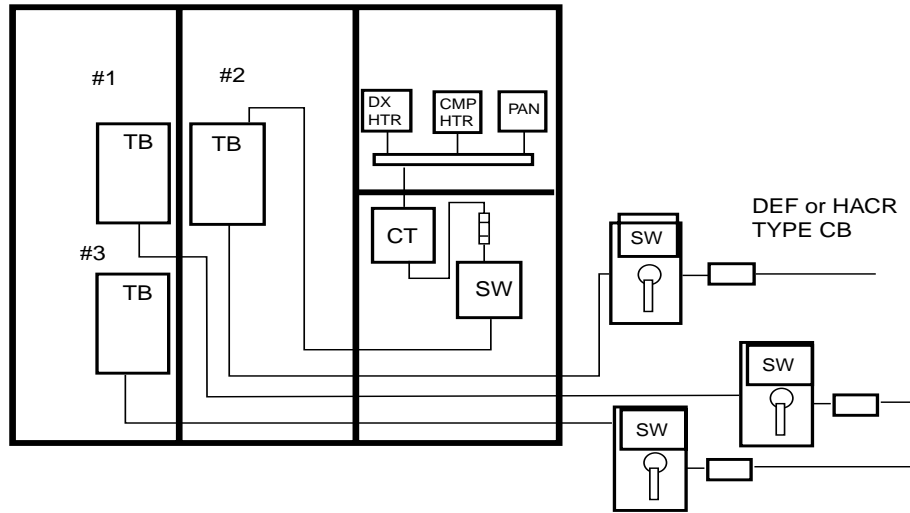

LD04370

CONTROL (120-1-60) SUPPLY WITHOUT STANDARD CONTROL TRANSFORMER

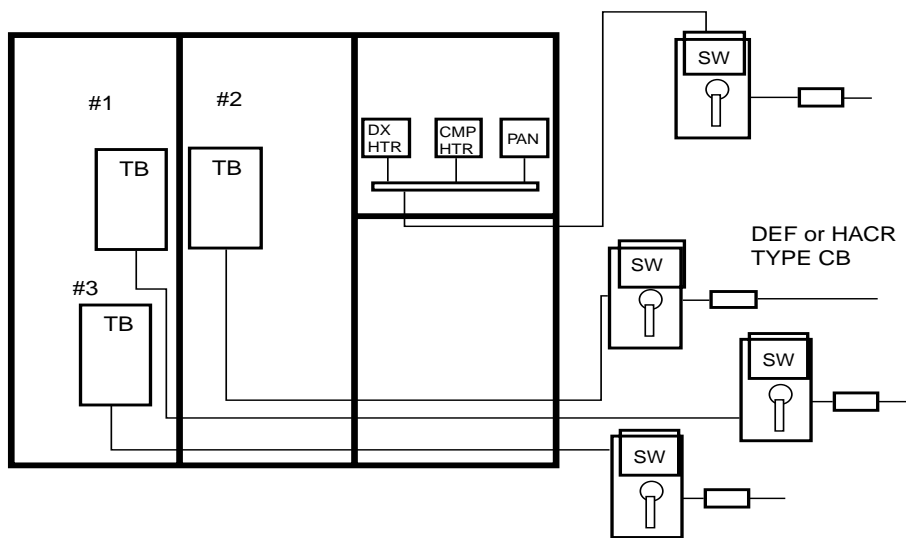

LD04371

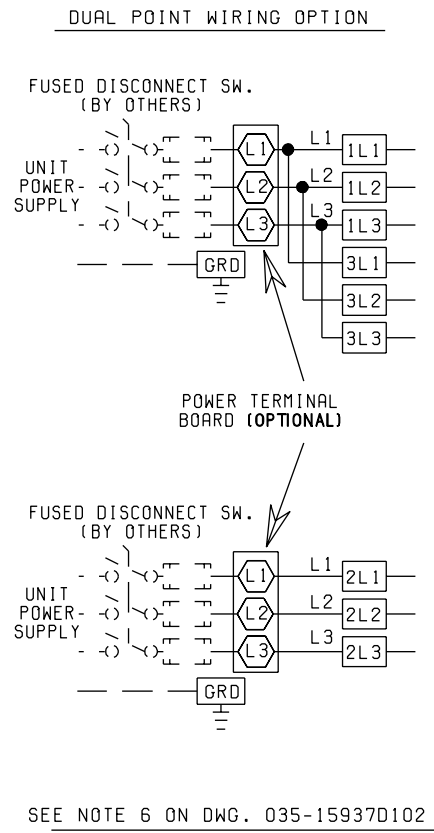
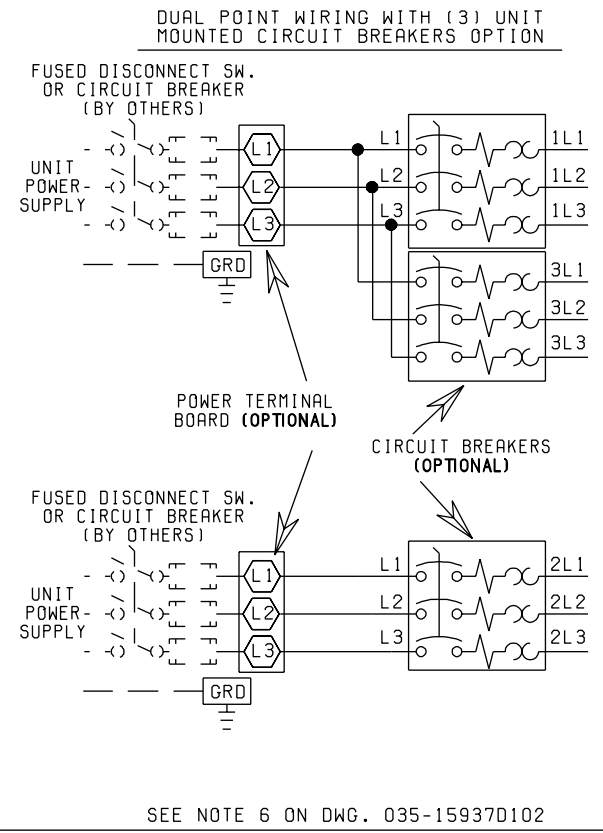
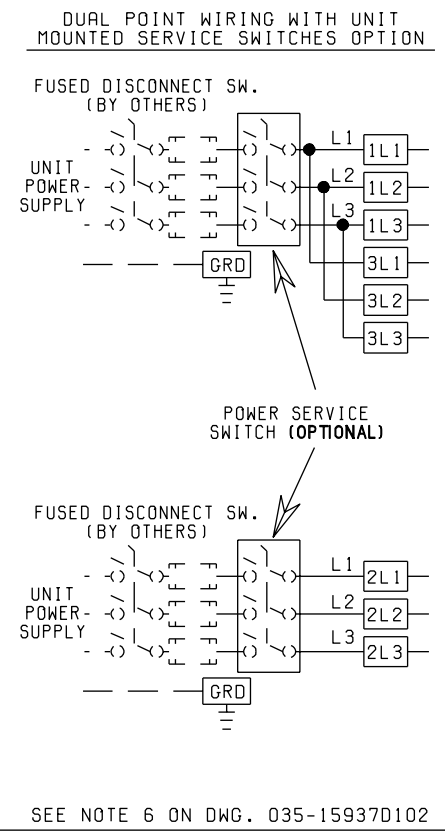

035-15937E103
REV. NONE

LD04172A

ELEMENTARY DIAGRAM

100
105
110
115
120
125
130
135
140
145
150
155

ELEMENTARY DIAGRAM
DXST DIRECT DRIVE
POWER CIRCUIT

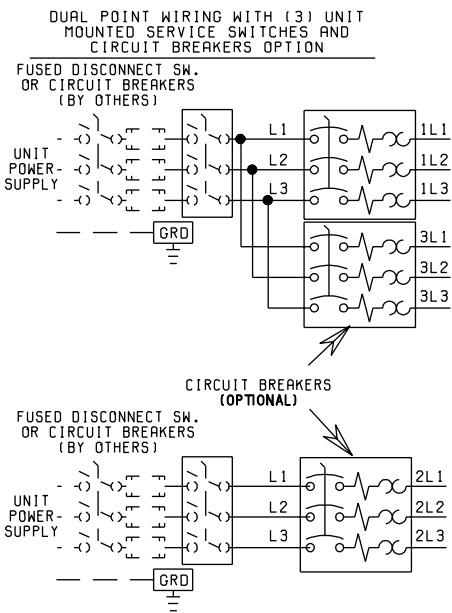

SEE NOTE 6 ON DWG. 035-15937D102

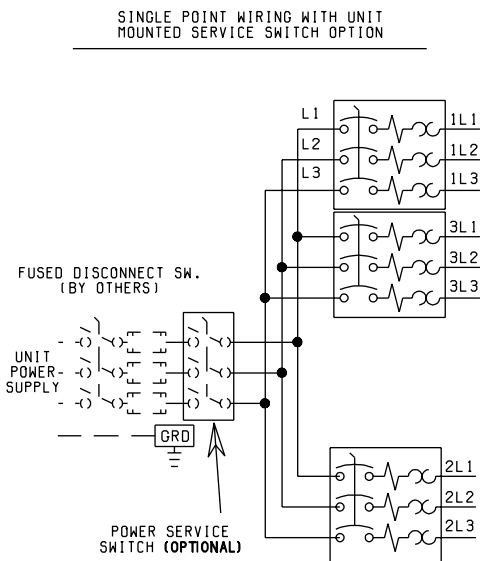

SEE NOTE 6 ON DWG. 035-15937D102

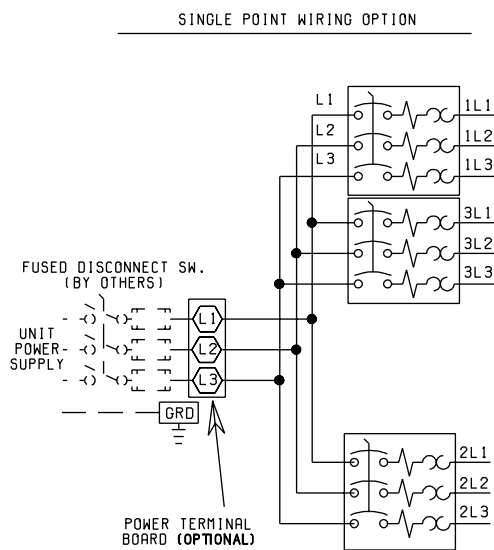

SEE NOTE 6 ON DWG. 035-15937D102

FIG. 2 – ELEMENTARY DIAGRAM

STANDARD COMPRESSOR POWER SUPPLIES ACROSS-THE-LINE START

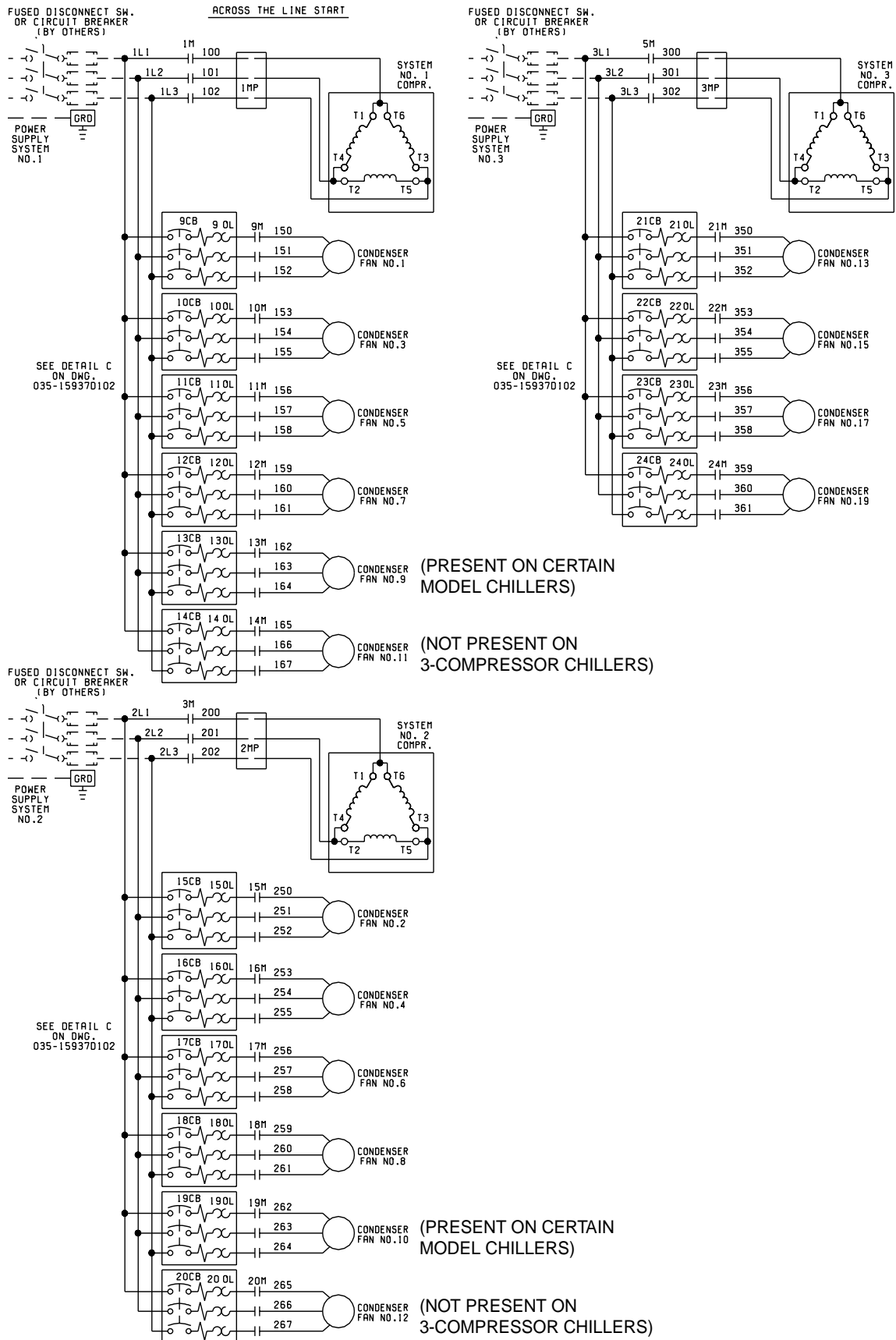

LD04173

FIG. 3 – STANDARD COMPRESSOR POWER SUPPLY - ACROSS-THE-LINE START

STANDARD COMPRESSOR POWER SUPPLIES WYE-DELTA START

160
165
170
175
180
185

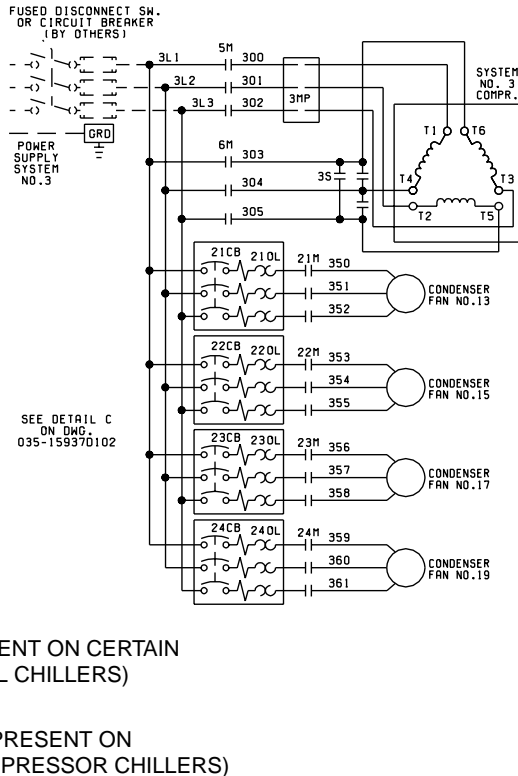
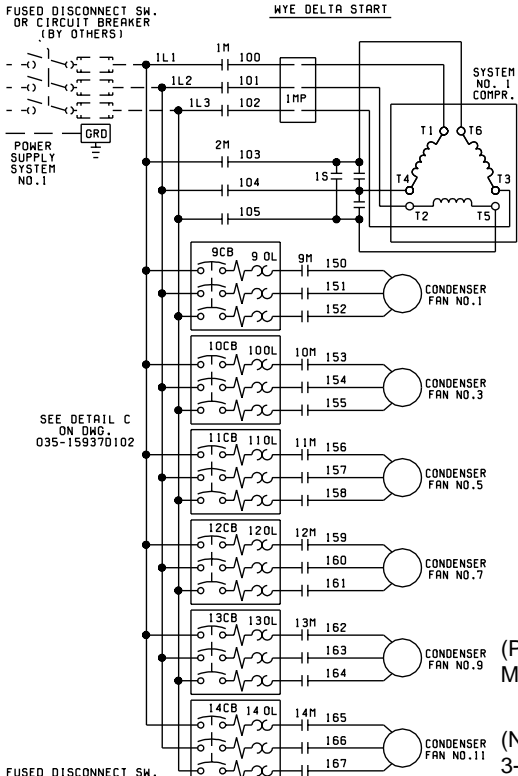

190
195
200
205
210
215
220
225
230
235
240
245
250
255
260
265
270
275
280
285
290
295
300
305
310
315
320
325
330
335
340
345
350
355
360
365
370

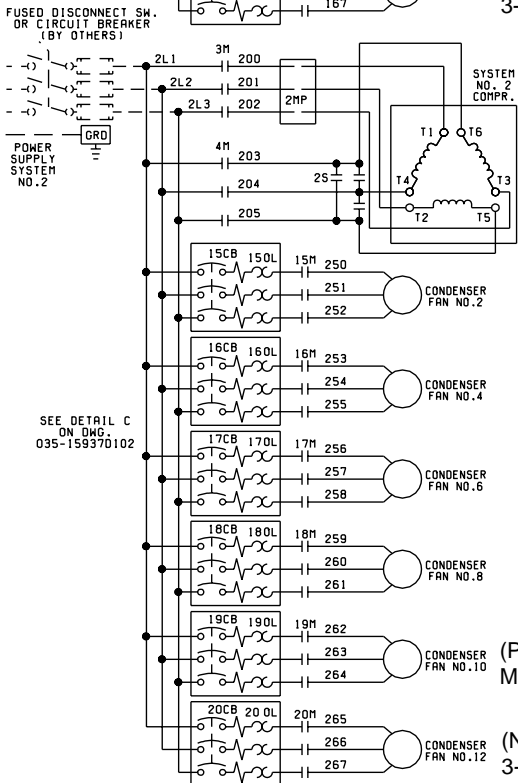

(PRESENT ON CERTAIN MODEL CHILLERS)
(NOT PRESENT ON 3-COMPRESSOR CHILLERS)
(PRESENT ON CERTAIN MODEL CHILLERS)
(NOT PRESENT ON 3-COMPRESSOR CHILLERS)

FIG. 4 – STANDARD COMPRESSOR POWER SUPPLY - WYE-DELTA START

STANDARD COMPRESSOR POWER SUPPLIES
ACROSS-THE-LINE START

ELEMENTARY DIAGRAM
DXST DIRECT DRIVE
CONTROL CIRCUIT

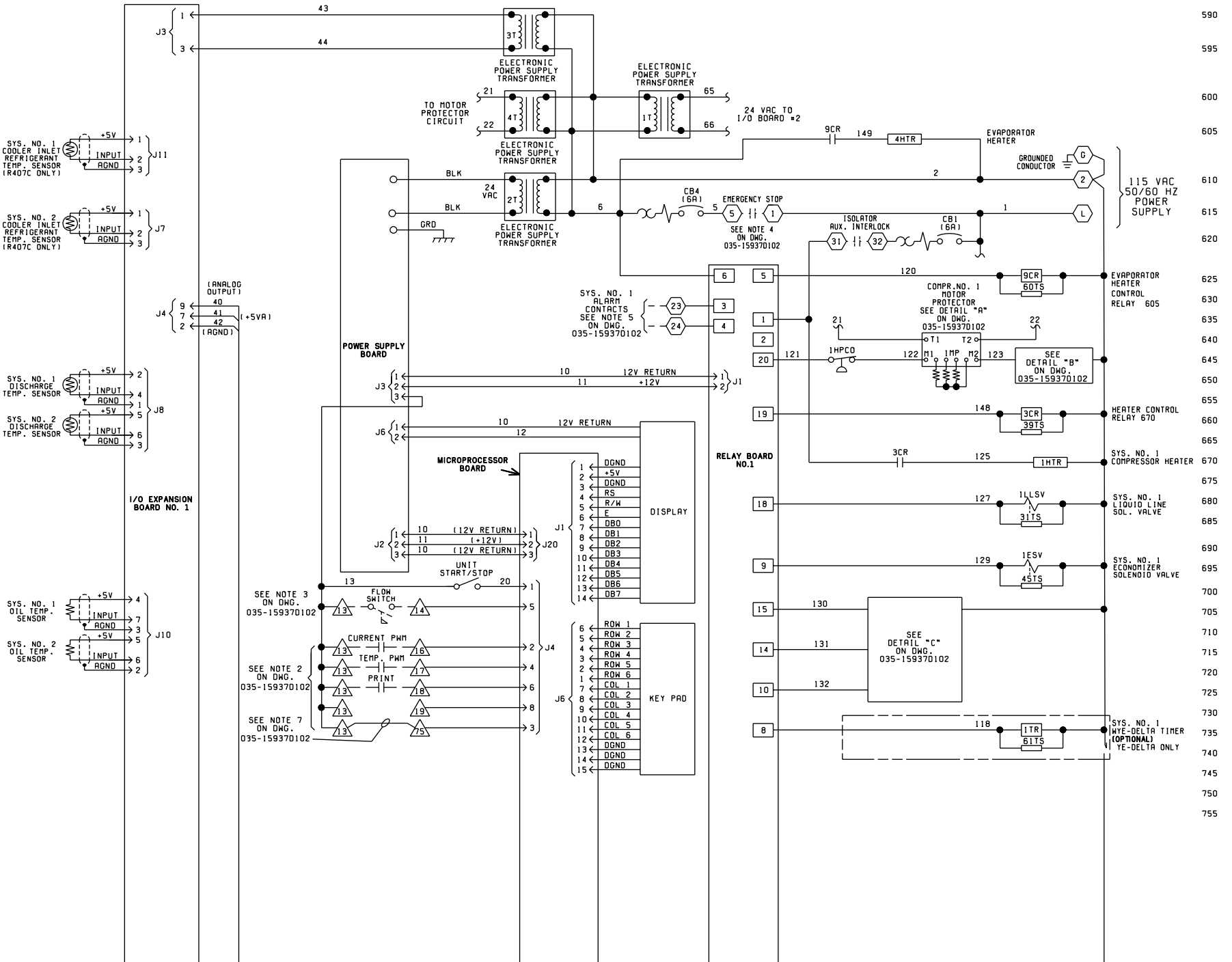
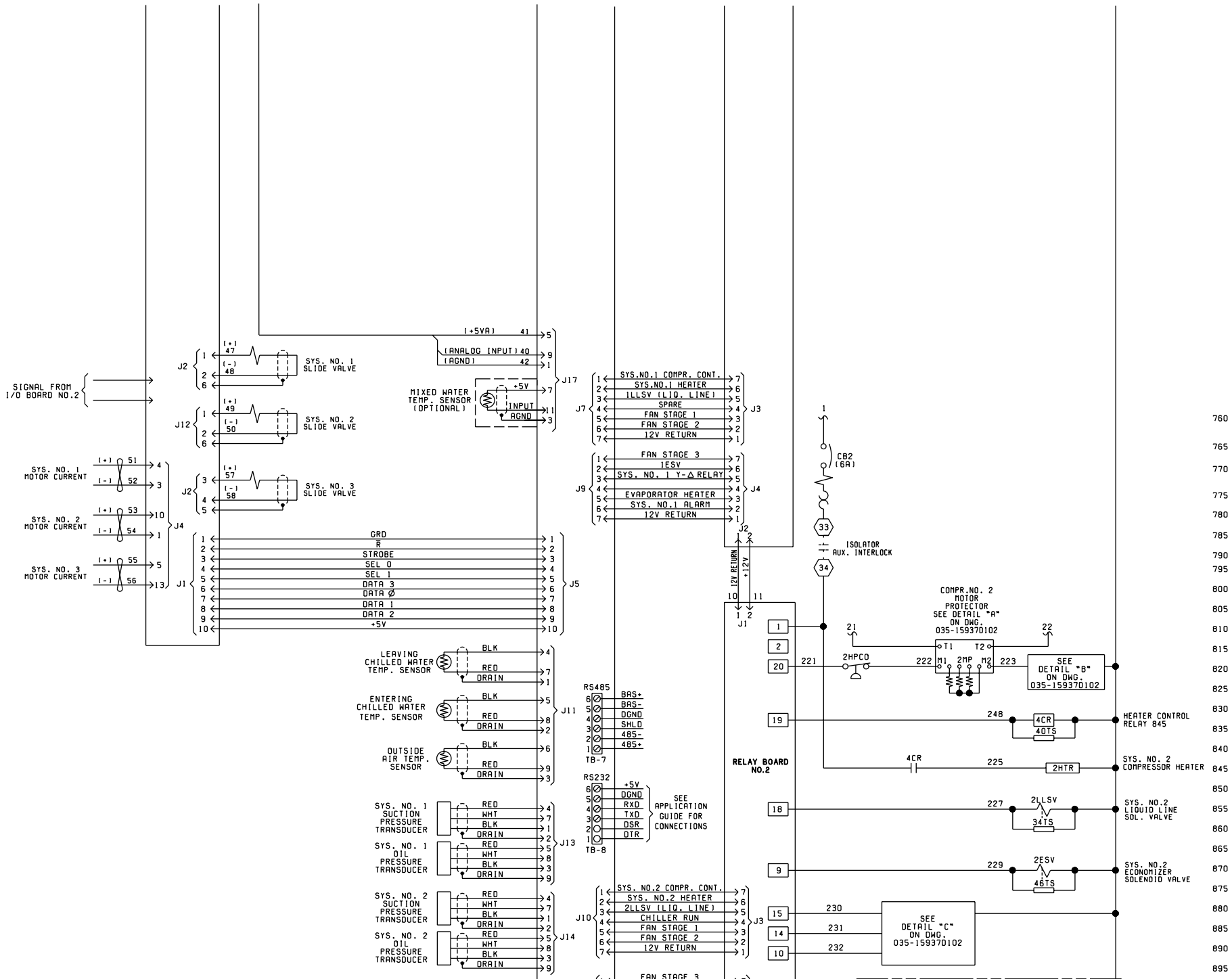
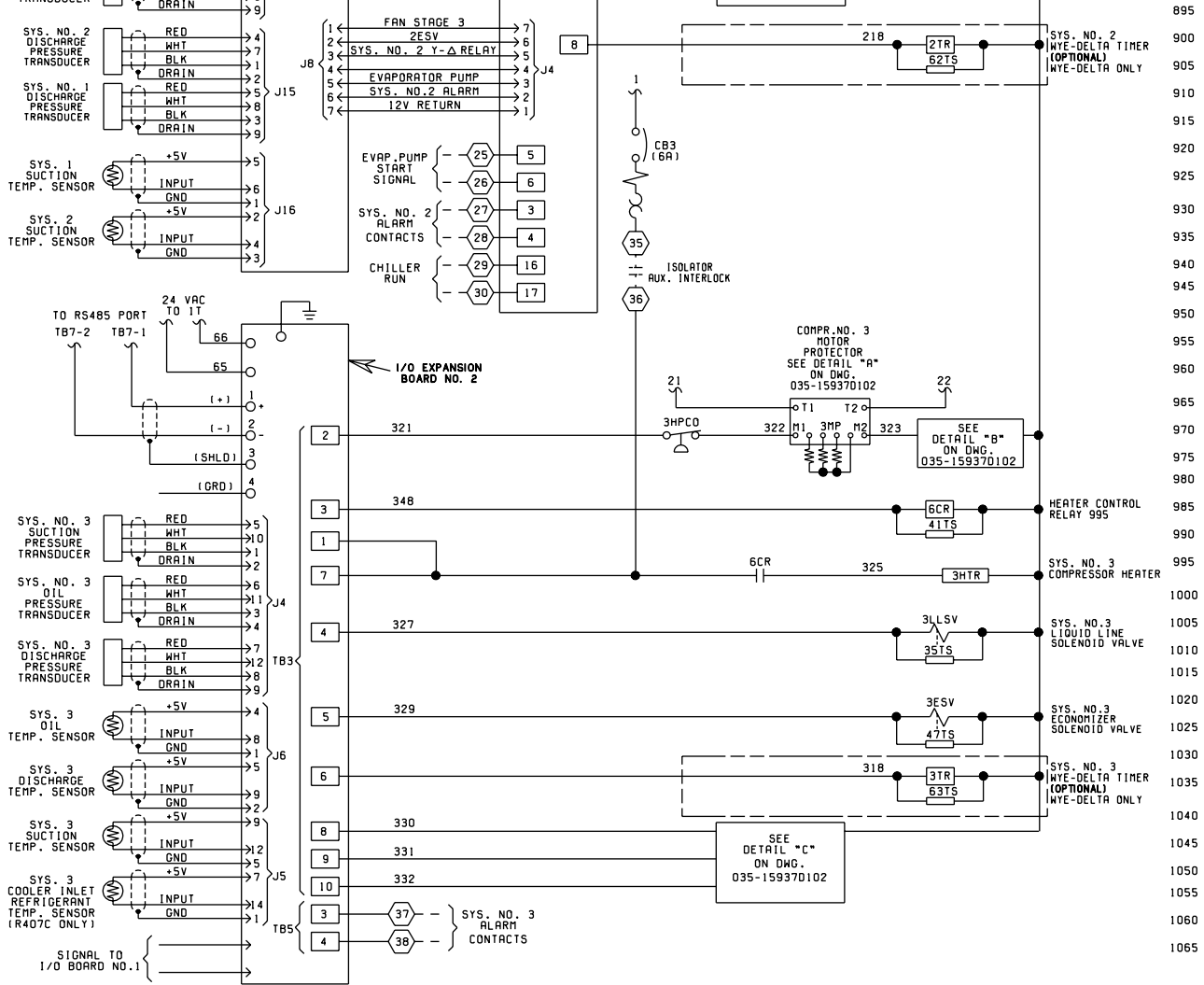
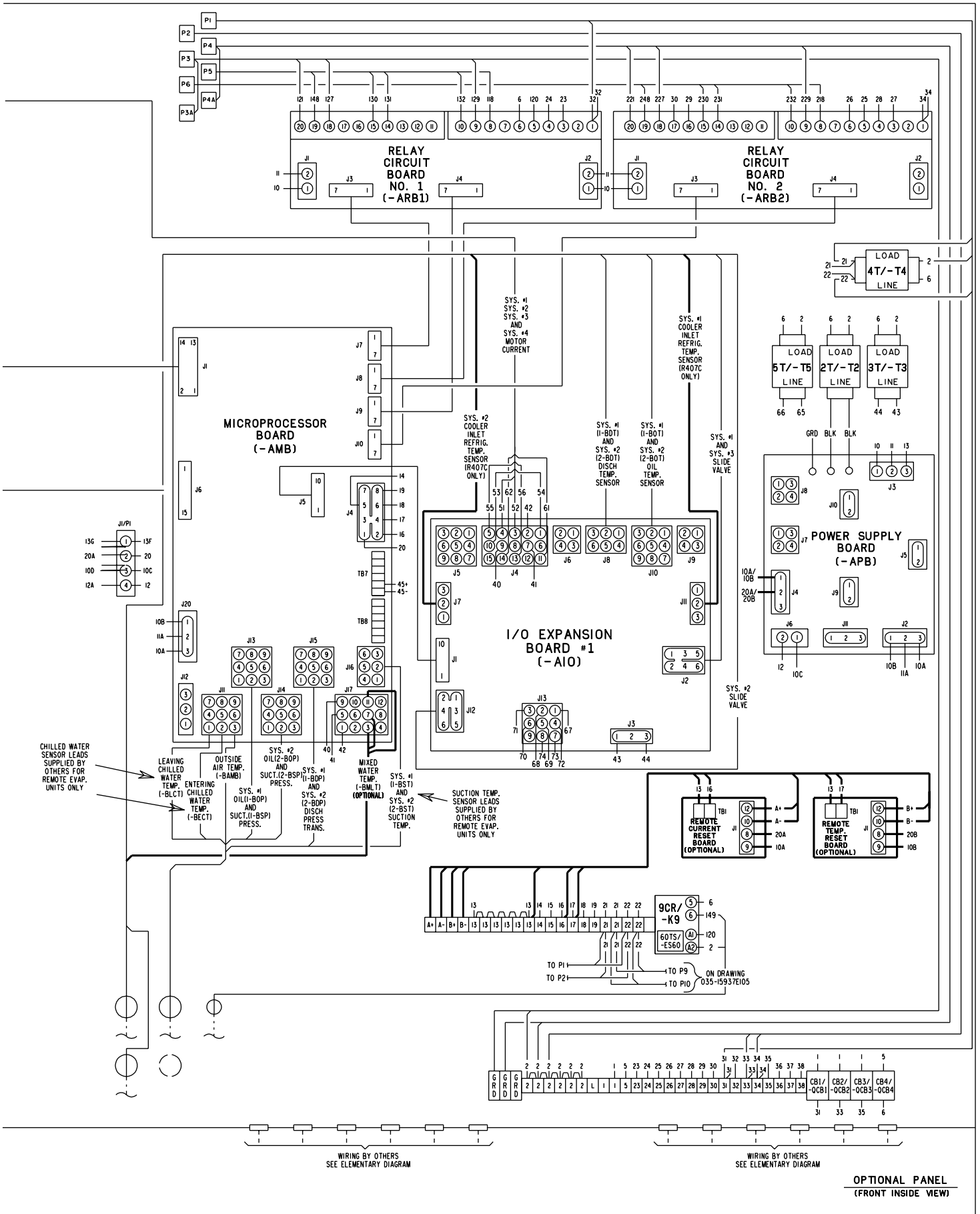

FIG. 5 - ELEMENTARY DIAGRAM



760
765
770
775
780
785
790
795
800
805
810
815
820
825
830
835
840
845
850
855
860
865
870
875
880
885
890
895





CONNECTION DIAGRAM

Box Information continued from page 20

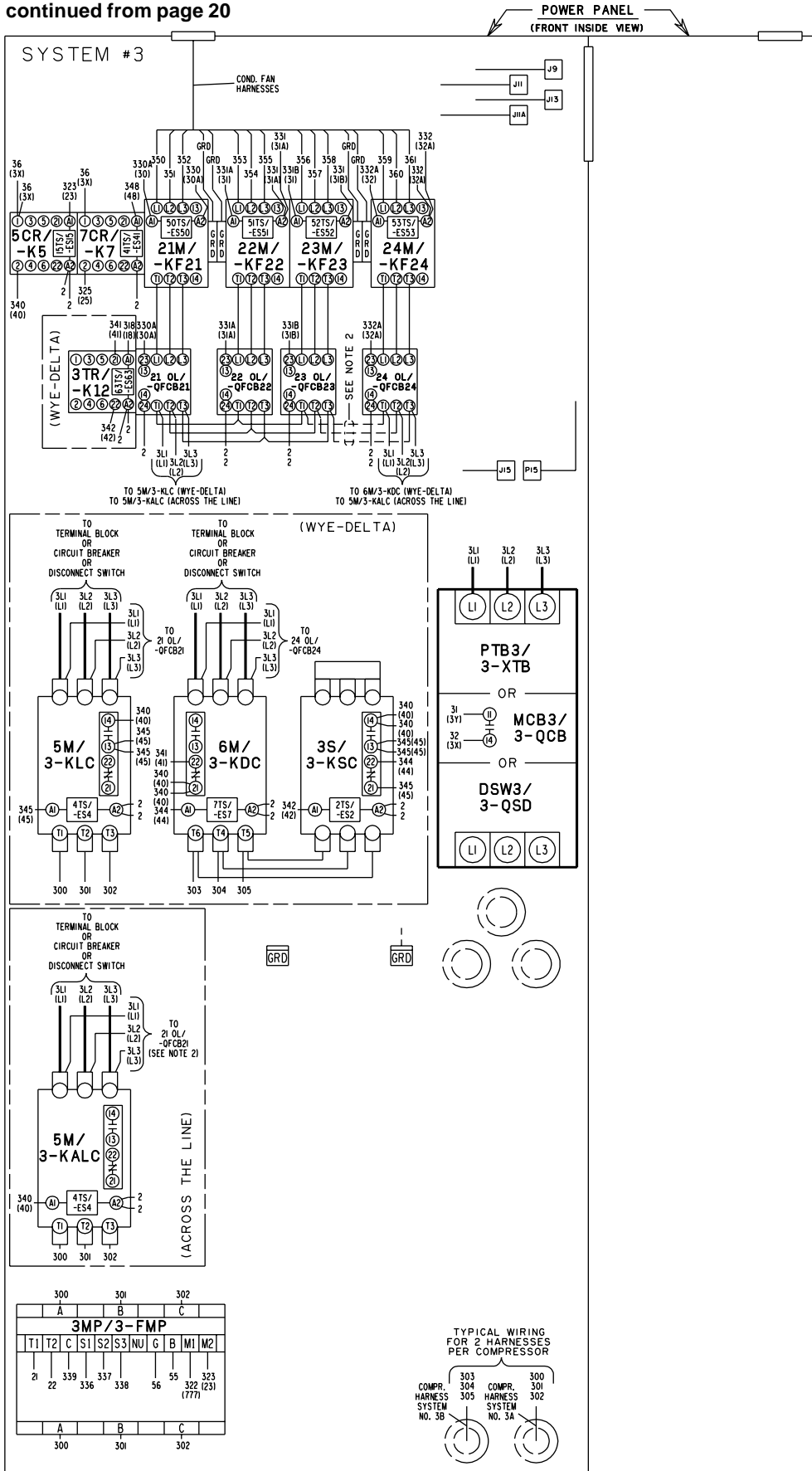

FIG. 7 – CONNECTION DIAGRAM

LD04180

FIG. 9 - CONNECTION DIAGRAM

1CR THRU 4CR, 9CR/ -CONTROL RELAYS
 -K1 THRU -K4, -K9
 CB1, CB2, CB3/ -CIRCUIT BREAKERS
 -OCB1, -OCB2, -OCB3
 9CB THRU 13CB -OVERLOAD CIRCUIT BREAKERS (SYS. #1)
 15CB THRU 19CB -OVERLOAD CIRCUIT BREAKERS (SYS. #2)
 9 OL THRU 13 OL -MOTOR OVERLOADS (SYS. #1)
 15 OL THRU 19 OL -MOTOR OVERLOADS (SYS. #2)
 -QFCB9 THRU -QFCB13 -MOTOR OVERLOADS W/OVERLOAD CIRCUIT BREAKERS (SYS. #1)
 -QFCB15 THRU -QFCB19 -MOTOR OVERLOADS W/OVERLOAD CIRCUIT BREAKERS (SYS. #2)

LEGEND

1M, 3M/ -COMPRESSOR CONTACTORS
 1-KLC OR 1-KALC, 2-KLC OR 2-KALC
 2M, 4M/ -COMPRESSOR CONTACTORS
 1-KDC, 2-KDC -COMPRESSOR CONTACTORS
 1S, 2S/ -COMPRESSOR CONTACTORS
 1-KSC, 2-KSC -CONDENSER FAN CONTACTORS
 9M THRU 13M/ -CONDENSER FAN CONTACTORS (SYS. #1)
 -KF9 THRU -KF13 (SYS. #1)
 15M THRU 19M/ -CONDENSER FAN CONTACTORS (SYS. #2)
 -KF15 THRU -KF19 (SYS. #2)
 1MP/1-FMP -MOTOR PROTECTOR (SYS. #1)
 2MP/2-FMP -MOTOR PROTECTOR (SYS. #2)

2T, 3T, 4T/ -MICRO PANEL TRANSFORMERS
 -T2, -T3, -T4
 1TR, 2TR/ -TIMER RELAYS
 -K10, -K11
 TS/-ES -TRANSIENT SUPPRESSORS
 PTB1, PTB2/ -POWER TERMINAL BLOCK
 1-XTB, 2-XTB -MOTOR CIRCUIT BREAKER
 MCB1, MCB2/ 1-OCB, 2-OCB -DISCONNECT SERVICE SWITCH
 DSW1, DSW2/ 1-QSD, 2-QSD
 --- -WIRING BY YORK
 - - - - -WIRING BY OTHERS
 - - - - -OPTIONAL WIRING AND/OR COMPONENTS



CONNECTION DIAGRAM, ELEC. BOX
 YCAS 130-230
 YCAS 373-653
 (STYLE F)
 STANDARD AND REMOTE EVAP. UNITS

J1, J2, J3, J3A, J4, J4A, — POWER PANEL
 J5, J6, J7, J8, P7 & P8
 P1, P2, P3, P3A, — ELECTRONIC (MICRO) PANEL
 P4, P4A, P5, & P6

NOTE: 1. WIRE NUMBERS IDENTIFIED IN (PARENTHESIS) INDICATE THE ACTUAL HARNESS CODE STAMPED ON THE WIRE.
 2. FOR 380V-575V CHILLERS, POWER TO 4TH AND 5TH FANS IS VIA JUMPERS FROM 3RD MANUAL STARTER. FOR 200V-230V CHILLERS A SECOND POWER FEED IS PROVIDED AS SHOWN.

PLUG NO.	WIRE NO.	PLUG PIN NO.
P1	21	1
	2	2
	22	3
	31	4
	32	5
P2	21	1
	2	2
	22	3
	33	4
	34	5
P3	2	1
	GRD	2
	125	4
	129	5
	127	6
	121	11
	122	12
P4	2	1
	GRD	2
	225	3
	227	4
	229	5
P5	130	1
	131	2
	132	3
	148	4
	118	6
P6	230	1
	231	2
	232	3
	248	4
	218	6
P7	125	1
	2	2
	123	3
	140	4
	141	5
	142	6
	32	7
P8	225	1
	2	2
	223	3
	240	4
	241	5
P9	2	1
	GRD	2
	225A	3
	227A	4
	229A	5
P10	2	1
	GRD	2
	48	4
	18	6
	P11	30
31		2
32		3
48		4
18		6
P12	30	1
	31	2
	32	3
	48	4
	18	6
P13	2	1
	GRD	2
	125A	4
	129A	5
	127A	6
P14	2	1
	GRD	2
	225A	3
	227A	4
	229A	5
P15	2	1
	GRD	2
	48	4
	18	6
	P16	25
2		2
23		3
40		4
41		5
P17	25	1
	2	2
	23	3
	40	4
	41	5
P18	25	1
	2	2
	23	3
	40	4
	41	5
P19	25	1
	2	2
	23	3
	40	4
	41	5
P20	25	1
	2	2
	23	3
	40	4
	41	5
P21	25	1
	2	2
	23	3
	40	4
	41	5
P22	25	1
	2	2
	23	3
	40	4
	41	5
P23	25	1
	2	2
	23	3
	40	4
	41	5
P24	25	1
	2	2
	23	3
	40	4
	41	5
P25	25	1
	2	2
	23	3
	40	4
	41	5
P26	25	1
	2	2
	23	3
	40	4
	41	5
P27	25	1
	2	2
	23	3
	40	4
	41	5
P28	25	1
	2	2
	23	3
	40	4
	41	5
P29	25	1
	2	2
	23	3
	40	4
	41	5
P30	25	1
	2	2
	23	3
	40	4
	41	5
P31	25	1
	2	2
	23	3
	40	4
	41	5
P32	25	1
	2	2
	23	3
	40	4
	41	5
P33	25	1
	2	2
	23	3
	40	4
	41	5
P34	25	1
	2	2
	23	3
	40	4
	41	5
P35	25	1
	2	2
	23	3
	40	4
	41	5
P36	25	1
	2	2
	23	3
	40	4
	41	5
P37	25	1
	2	2
	23	3
	40	4
	41	5
P38	25	1
	2	2
	23	3
	40	4
	41	5
P39	25	1
	2	2
	23	3
	40	4
	41	5
P40	25	1
	2	2
	23	3
	40	4
	41	5
P41	25	1
	2	2
	23	3
	40	4
	41	5
P42	25	1
	2	2
	23	3
	40	4
	41	5
P43	25	1
	2	2
	23	3
	40	4
	41	5
P44	25	1
	2	2
	23	3
	40	4
	41	5
P45	25	1
	2	2
	23	3
	40	4
	41	5
P46	25	1
	2	2
	23	3
	40	4
	41	5
P47	25	1
	2	2
	23	3
	40	4
	41	5
P48	25	1
	2	2
	23	3
	40	4
	41	5
P49	25	1
	2	2
	23	3
	40	4
	41	5
P50	25	1
	2	2
	23	3
	40	4
	41	5
P51	25	1
	2	2
	23	3
	40	4
	41	5
P52	25	1
	2	2
	23	3
	40	4
	41	5
P53	25	1
	2	2
	23	3
	40	4
	41	5
P54	25	1
	2	2
	23	3
	40	4
	41	5
P55	25	1
	2	2
	23	3
	40	4
	41	5
P56	25	1
	2	2
	23	3
	40	4
	41	5
P57	25	1
	2	2
	23	3
	40	4
	41	5
P58	25	1
	2	2
	23	3
	40	4
	41	5
P59	25	1
	2	2
	23	3
	40	4
	41	5
P60	25	1
	2	2
	23	3
	40	4
	41	5
P61	25	1
	2	2
	23	3
	40	4
	41	5
P62	25	1
	2	2
	23	3
	40	4
	41	5
P63	25	1
	2	2
	23	3
	40	4
	41	5
P64	25	1
	2	2
	23	3
	40	4
	41	5
P65	25	1
	2	2
	23	3
	40	4
	41	5
P66	25	1
	2	2
	23	3
	40	4
	41	5
P67	25	1
	2	2
	23	3
	40	4
	41	5
P68	25	1
	2	2
	23	3
	40	4
	41	5
P69	25	1
	2	2
	23	3
	40	4
	41	5
P70	25	1
	2	2
	23	3
	40	4
	41	5
P71	25	1
	2	2
	23	3
	40	4
	41	5
P72	25	1
	2	2
	23	3
	40	4
	41	5
P73	25	1
	2	2
	23	3
	40	4
	41	5
P74	25	1
	2	2
	23	3
	40	4
	41	5
P75	25	1
	2	2
	23	3
	40	4
	41	5
P76	25	1
	2	2
	23	3
	40	4
	41	5
P77	25	1
	2	2
	23	3
	40	4
	41	5
P78	25	1
	2	2
	23	3
	40	4
	41	5
P79	25	1
	2	2
	23	3
	40	4
	41	5
P80	25	1
	2	2
	23	3
	40	4
	41	5
P81	25	1
	2	2
	23	3
	40	4
	41	5
P82	25	1
	2	2
	23	3
	40	4
	41	5
P83	25	1
	2	2
	23	3
	40	4
	41	5
P84	25	1
	2	2
	23	3
	40	4
	41	5
P85	25	1
	2	2
	23	3
	40	4
	41	5
P86	25	1
	2	2
	23	3
	40	4
	41	5
P87	25	1
	2	2
	23	3
	40	4
	41	5
P88	25	1
	2	2
	23	3
	40	4
	41	5
P89	25	1
	2	2
	23	3
	40	4
	41	5
P90	25	1
	2	2
	23	3

FIG. 10 - CONNECTION DIAGRAM

5CR & 7CR/ -K5 & -K7	-CONTROL RELAYS
CB4, CB5, CB6/ -OCB4, -OCB5, -OCB6	-CIRCUIT BREAKERS
21CB THRU 24CB	-OVERLOAD CIRCUIT BREAKERS (SYS. #3)
21 OL THRU 24 OL	-MOTOR OVERLOADS (SYS. #3)
-OFCB21 THRU -OFCB24	-MOTOR OVERLOADS W/OVERLOAD CIRCUIT BREAKERS (SYS. #3)
3FU, 4FU/ -F3, -F4	-TRANSFORMER FUSE (OPTIONAL)

LEGEND

5M	-COMPRESSOR CONTACTORS
3-KLC OR 3-KALC	-COMPRESSOR CONTACTORS
6M, 8M/	-COMPRESSOR CONTACTORS
3-KDC	-COMPRESSOR CONTACTORS
3S	-COMPRESSOR CONTACTORS
3-KSC	-CONDENSER FAN CONTACTORS
21M THRU 24M/ -KF21 THRU -KF24	-MOTOR OVERLOADS (SYS. #3)
3MP/3-FMP	-MOTOR PROTECTOR (SYS. #3)
1T/-11	-CONTROL TRANSFORMER 2KVA (OPTIONAL)

6T, 7T, 8T/ -16, -17, -18	-MICRO PANEL TRANSFORMERS
3TR,	-TIMER RELAYS
-K12, -K13	-TRANSIENT SUPPRESSORS
TS/-ES	-POWER TERMINAL BLOCK
PTB3, PTB4/ 3-XTB,	-MOTOR CIRCUIT BREAKER
MCB3, MCB4/ 3-OCB,	-DISCONNECT SERVICE SWITCH
DSW3, DSW4/ 3-OSD,	-WIRING BY YORK
---	-WIRING BY OTHERS
---	-OPTIONAL WIRING AND/OR COMPONENTS

CONNECTION DIAGRAM, ELEC. BOX
 YCAS 130-230
 YCAS 373-653
 (STYLE F)
 STANDARD AND REMOTE EVAP. UNITS

J9, J11, J14, J13, J15, P15 — POWER PANEL
 P9, P11, P14, P13, — ELECTRONIC (MICRO) PANEL

NOTE: 1. WIRE NUMBERS IDENTIFIED IN (PARENTHESIS) INDICATE THE ACTUAL HARNESS CODE STAMPED ON THE WIRE.
 2. FOR 380V-575V CHILLERS, POWER TO 4TH AND 5TH FANS IS VIA JUMPERS FROM 3RD MANUAL STARTER. FOR 200V-230V CHILLERS A SECOND POWER FEED IS PROVIDED AS SHOWN.

PLUG NO.	WIRE NO.	PLUG PIN NO.
P9	21	1
	2	2
	22	3
	35	4
	36	5
J9	21	1
	2	2
	22	3
	37	4
	3X	5
P14	325	1
	322	2
P11A	25	1
	777	2

PLUG NO.	WIRE NO.	PLUG PIN NO.
P11	2	1
	GRD	2
	325	3
	329	5
	327	4
	321	11
	322	12
J11	2	1
	GRD	2
	325A	3
	329A	5
	327A	4
	321A	11
	322	12

PLUG NO.	WIRE NO.	PLUG PIN NO.
P13	330	1
	331	2
	332	3
	348	6
	318	6

PLUG NO.	WIRE NO.	PLUG PIN NO.
J13	30	1
	31	2
	32	3
	48	4
	18	6

PLUG NO.	WIRE NO.	PLUG PIN NO.
P15	325	1
	2	2
	323	3
	340	4
	341	5
	342	6
	32	7

PLUG NO.	WIRE NO.	PLUG PIN NO.
J15	25	1
	2	2
	23	3
	40	4
	41	5
	42	6
	3X	7

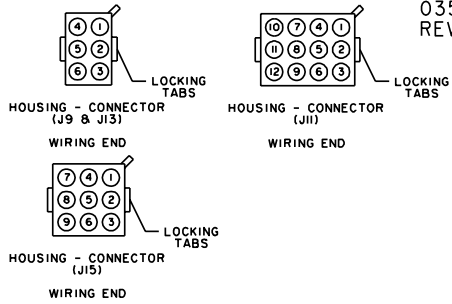

035-15937E105
 REV. NONE

LD04183

CONNECTION DIAGRAM - ELECTRICAL BOX
 YCAS0250 - 0330, YCAS0693 - 0953 (STYLE F)
 STANDARD & REMOTE EVAP. UNITS

ELEMENTARY DIAGRAM DXST DIRECT DRIVE CONTROL CIRCUIT

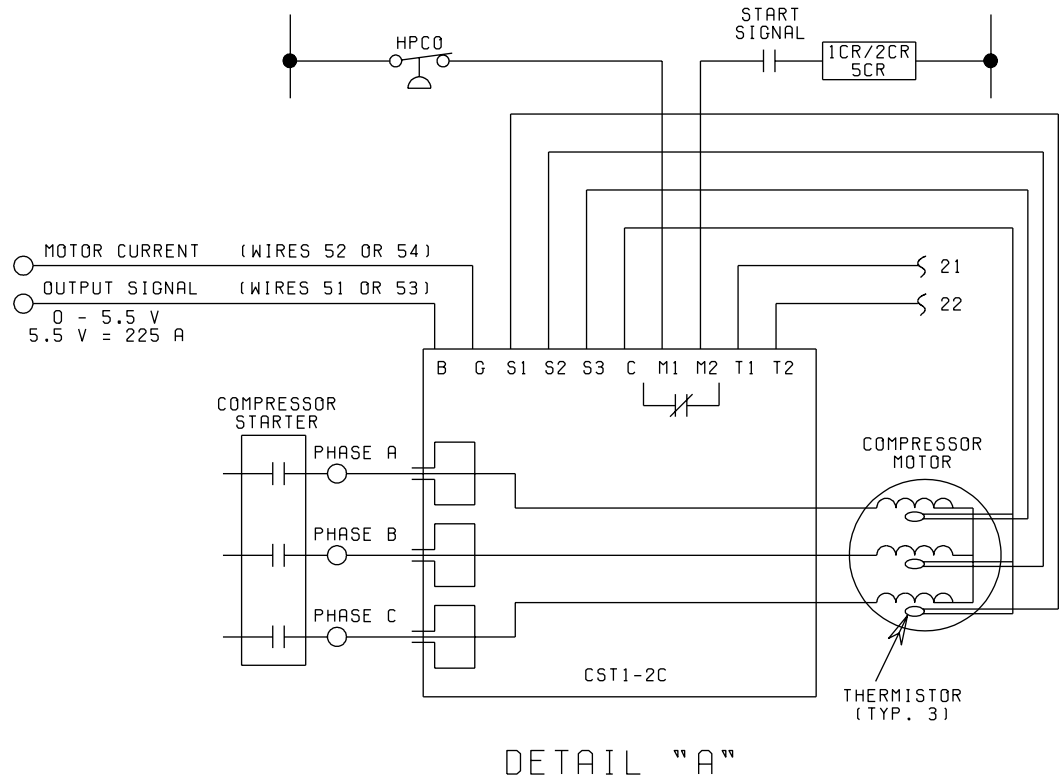

DETAIL "A"

NOTES:

1. FIELD WIRING TO BE IN ACCORDANCE WITH THE CURRENT EDITION OF THE NATIONAL ELECTRICAL CODE AS WELL AS ALL OTHER APPLICABLE CODES AND SPECIFICATIONS.
2. CONTACTS MUST BE SUITABLE FOR SWITCHING 24VDC. (GOLD CONTACTS RECOMMENDED). WIRING SHALL NOT BE RUN IN THE SAME CONDUIT WITH ANY LINE VOLTAGE WIRING.
3. TO CYCLE UNIT ON AND OFF AUTOMATICALLY WITH CONTACT SHOWN, INSTALL A CYCLING DEVICE IN SERIES WITH THE FLOW SWITCH (FLSW). SEE NOTE 2 FOR CONTACT RATING AND WIRING SPECIFICATIONS.
4. TO STOP UNIT (EMERGENCY STOP) WITH CONTACTS OTHER THAN THOSE SHOWN, INSTALL THE STOP CONTACT BETWEEN TERMINALS 5 AND 1. IF A STOP DEVICE IS NOT INSTALLED, A JUMPER MUST BE CONNECTED BETWEEN TERMINALS 5 AND 1. DEVICE MUST HAVE A MINIMUM CONTACT RATING OF 100VA AT 115VOLTS A.C.
5. ALARM CONTACTS ARE FOR ANNUNCIATING ALARM/UNIT MALFUNCTION. CONTACTS ARE RATED AT 115V, 100VA, RESISTIVE LOAD ONLY, AND MUST BE SUPPRESSED AT LOAD BY USER.
6. SEE INSTALLATION, OPERATION AND MAINTENANCE MANUAL WHEN OPTIONAL EQUIPMENT IS USED.
7. JUMPER MUST BE INSTALLED FOR THREE COMPRESSOR OPERATION.

LEGEND	
TS	TRANSIENT VOLTAGE SUPPRESSION
⬡	TERMINAL BLOCK FOR CUSTOMER CONNECTIONS
⬠	TERMINAL BLOCK FOR CUSTOMER LOW VOLTAGE (CLASS 2) CONNECTIONS. SEE NOTE 2.
□	TERMINAL BLOCK FOR YORK CONNECTIONS ONLY
—	WIRING AND COMPONENTS BY YORK
- - -	OPTIONAL EQUIPMENT
- - - -	WIRING AND/OR COMPONENTS BY OTHERS

035-15937D102
REV. NONE

LD04177

FIG. 11 – ELEMENTARY DIAGRAM, DXST DIRECT DRIVE - CONTROL CIRCUIT

ELEMENTARY DIAGRAM DXST DIRECT DRIVE CONTROL CIRCUIT

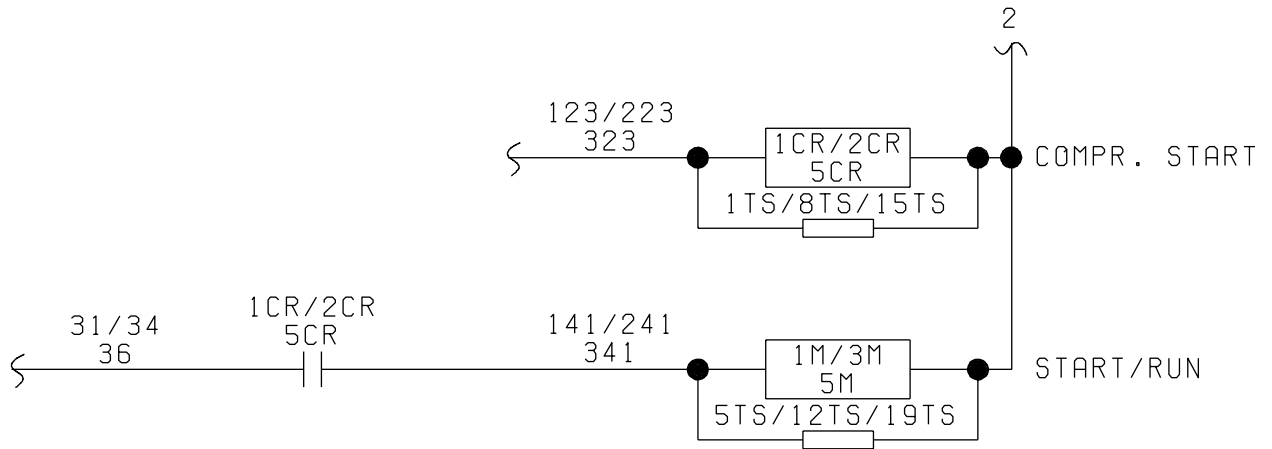

ACROSS THE LINE START

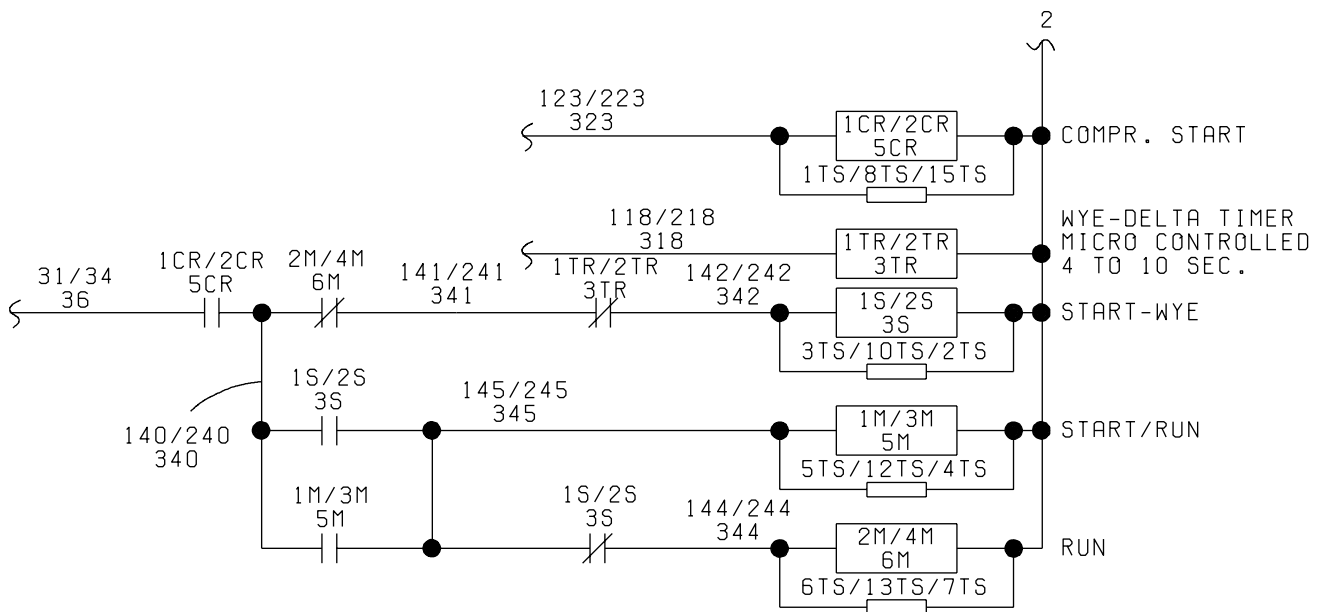

WYE DELTA START

DETAIL "B"

FIG. 12 – ELEMENTARY DIAGRAM, DXST DIRECT DRIVE - CONTROL CIRCUIT

ELEMENTARY DIAGRAM DXST DIRECT DRIVE CONTROL CIRCUIT

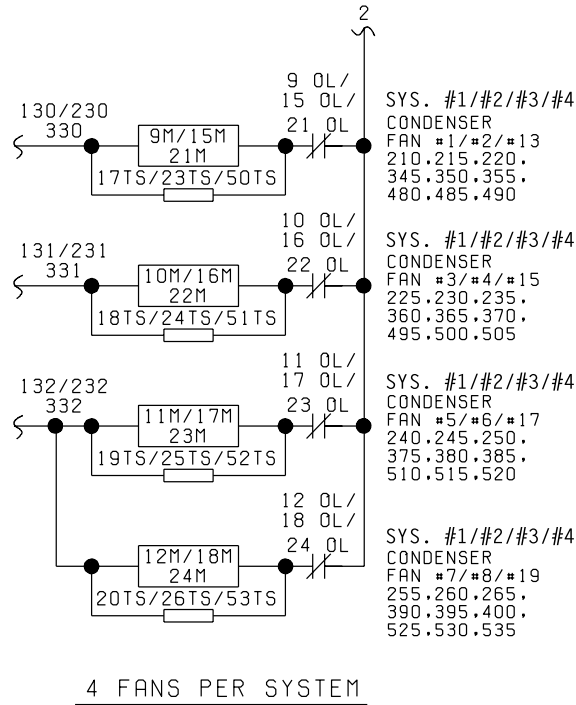

DETAIL "C"

SEE INSTALLATION, OPERATION AND MAINTENANCE MANUAL
FOR JUMPER OF CONDENSER FANS FOR CHILLER MODEL

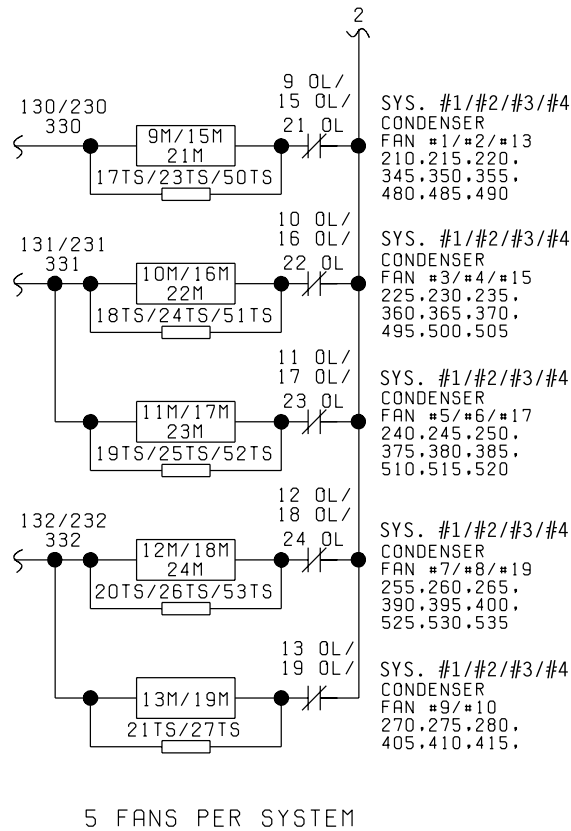

LD04374

FIG. 13 – ELEMENTARY DIAGRAM, DXST DIRECT DRIVE - CONTROL CIRCUIT

CONNECTION DIAGRAM SYSTEM WIRING STANDARD & REMOTE EVAP. UNITS

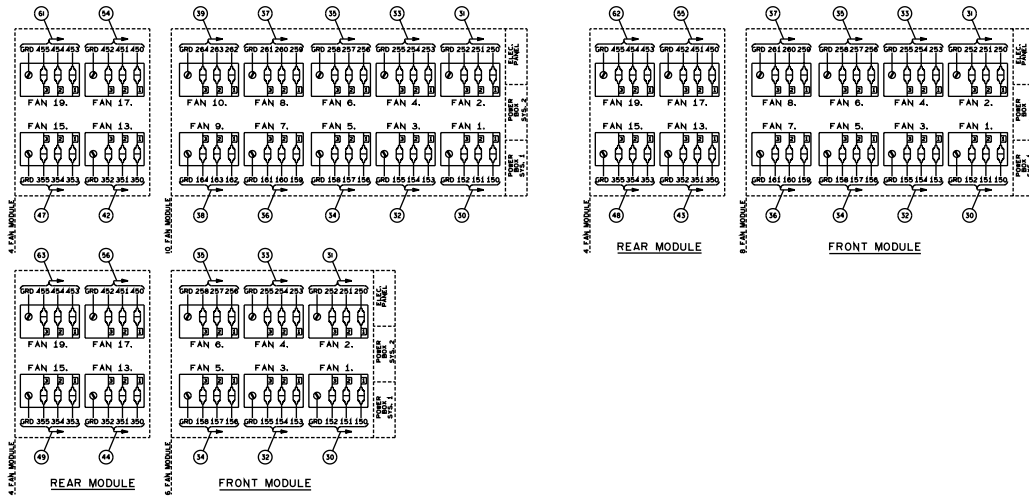

CONNECTION DIAGRAM SYSTEM WIRING
 YCAS 0250 - 0330
 YCAS 0693 - 0953
 YCAS 0747 - 0967
 (STYLE F)
 STANDARD & REMOTE EVAP. UNITS

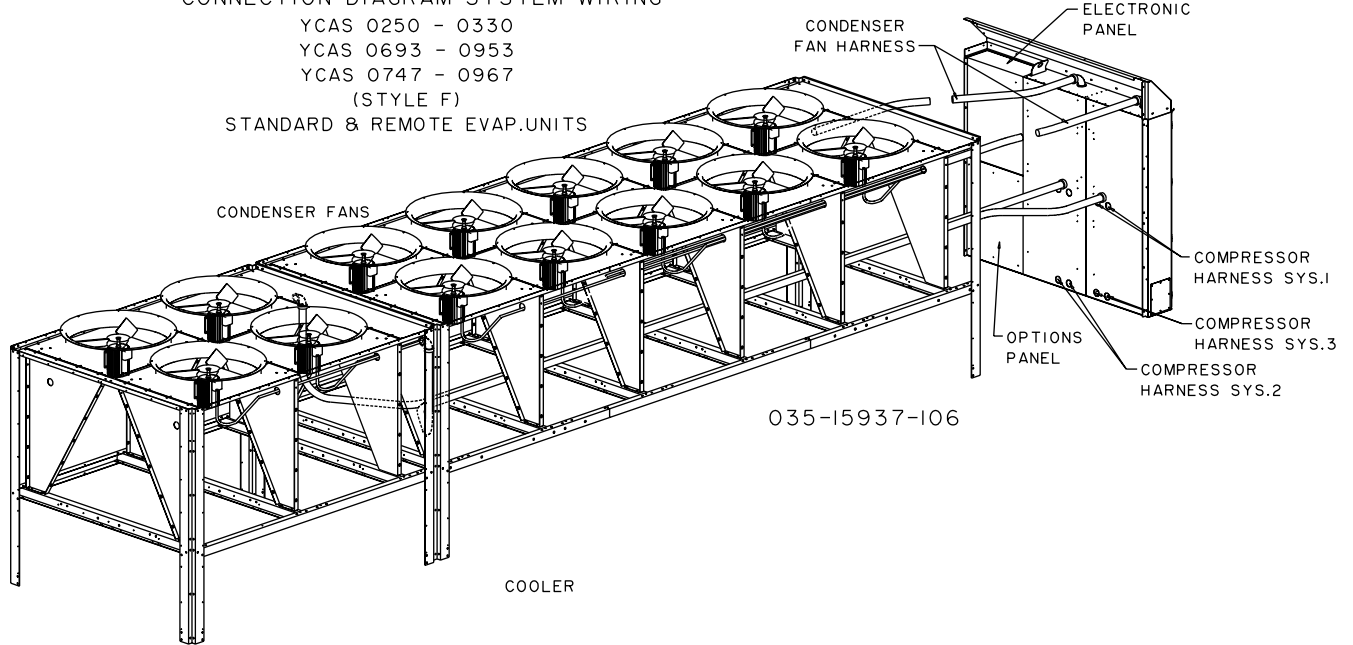

LEGEND

- 1 HPCO SYS. NO.1 HIGH PRESS. CUTOUT
- 2 HPCO SYS. NO.2 HIGH PRESS. CUTOUT
- 3 HPCO SYS. NO.3 HIGH PRESS. CUTOUT

- 1 HTR SYS.NO.1 COMPR. CRANKCASE HEATER
- 2 HTR SYS.NO.2 COMPR. CRANKCASE HEATER
- 3 HTR SYS.NO.3 COMPR. CRANKCASE HEATER
- 4 HTR COOLER HEATER

- 1 LLSV SYS.NO.1 LIQUID LINE SOLENIOD VALVE (UNIT IDENT)
- 2 LLSV SYS.NO.2 LIQUID LINE SOLENIOD VALVE (UNIT IDENT)
- 3 LLSV SYS.NO.3 LIQUID LINE SOLENIOD VALVE (UNIT IDENT)

- 1 ESV ECONOMIZER SOLENIOD VAVLE (UNIT IDENT)
- 2 ESV ECONOMIZER SOLENIOD VAVLE (UNIT IDENT)
- 3 ESV ECONOMIZER SOLENIOD VAVLE (UNIT IDENT)

- TXV 1 SYS.NO.1 THERMAL EXPANSION VALVE (UNIT IDENT)
- TXV 2 SYS.NO.2 THERMAL EXPANSION VALVE (UNIT IDENT)
- TXV 3 SYS.NO.3 THERMAL EXPANSION VALVE (UNIT IDENT)

FRONT MODULE

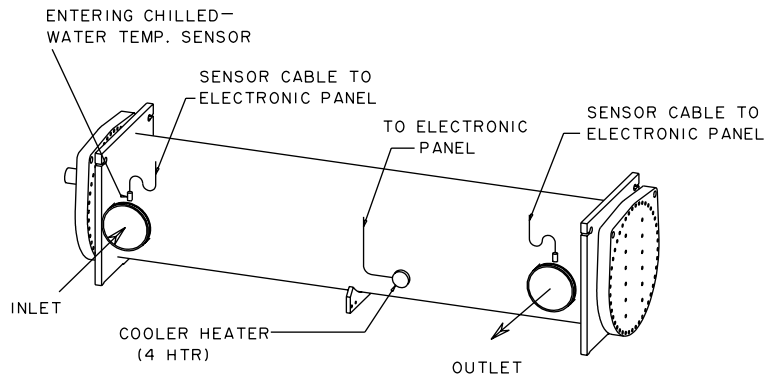
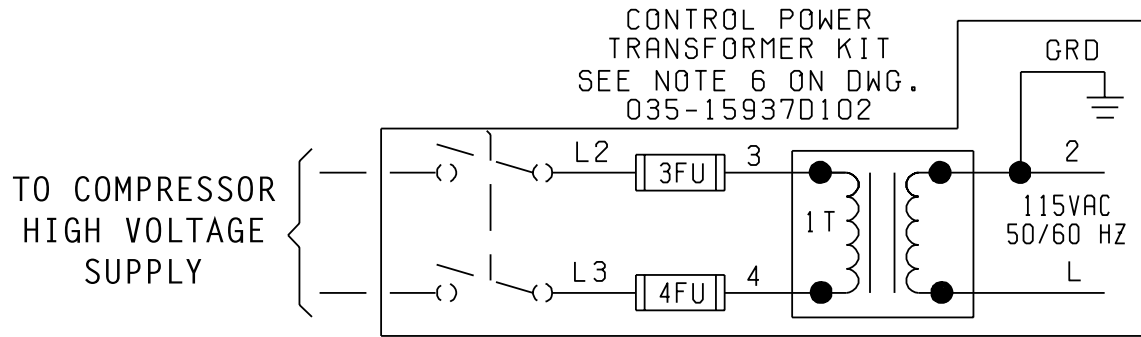

FIG. 14 – CONNECTION DIAGRAM SYSTEM WIRING

CONTROL POWER TRANSFORMER KIT



LD04186

FIG. 16 – CONTROL POWER TRANSFORMER KIT

